

## FEATURES

- 5V and 3.3V power supply options
- 200ps part-to-part skew
- 50ps output-to-output skew
- Differential design
- V<sub>BB</sub> output
- Voltage and temperature compensated outputs
- 75KΩ input pulldown resistors
- Fully compatible with Motorola MC100LVE111
- Available in 28-pin PLCC package



Precision Edge®

## DESCRIPTION

The SY10/100E111A/L are low skew 1-to-9 differential driver designed for clock distribution in mind. The SY10/100E111A/L's function and performance are similar to the popular SY10/100E111, with the improvement of lower jitter and the added feature of low voltage operation. It accepts one signal input, which can be either differential or single-ended if the V<sub>BB</sub> output is used. The signal is fanned out to 9 identical differential outputs.

The E111A/L are specifically designed, modeled and produced with low skew as the key goal. Optimal design and layout serve to minimize gate to gate skew within a device, and empirical modeling is used to determine process control limits that ensure consistent t<sub>pd</sub> distributions from lot to lot. The net result is a dependable, guaranteed low skew device.

To ensure that the tight skew specification is met it is necessary that both sides of the differential output are terminated into 50Ω, even if only one side is being used. In most applications, all nine differential pairs will be used and therefore terminated. In the case where fewer than nine pairs are used, it is necessary to terminate at least the output pairs on the same package side as the pair(s) being used on that side, in order to maintain minimum skew. Failure to do this will result in small degradations of propagation delay (on the order of 10-20ps) of the output(s) being used which, while not being catastrophic to most designs, will mean a loss of skew margin.

The E111A/L, as with most other ECL devices, can be operated from a positive V<sub>CC</sub> supply in PECL mode. This allows the E111A/L to be used for high performance clock distribution in +5V/+3.3V systems. Designers can take advantage of the E111A/L's performance to distribute low skew clocks across the backplane or the board. In a PECL environment, series or Thevenin line terminations are typically used as they require no additional power supplies. For systems incorporating GTL, parallel termination offers the lowest power by taking advantage of the 1.2V supply as terminating voltage.

## BLOCK DIAGRAM

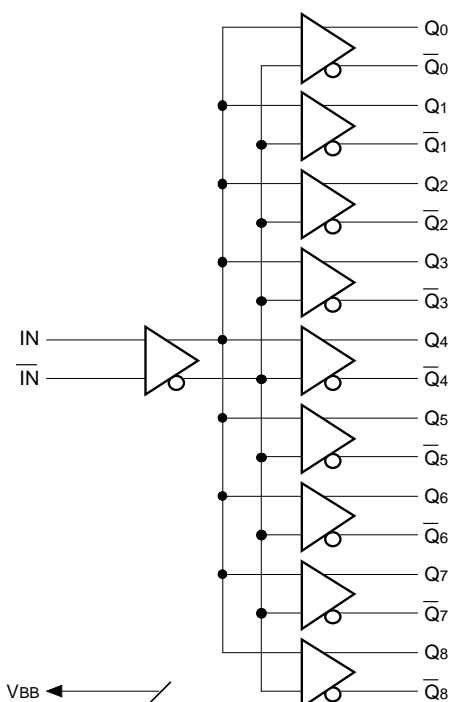

## PIN NAMES

Pin	Function
IN, $\overline{IN}$	Differential Input Pair
Q <sub>0</sub> , $\overline{Q_0}$ — Q <sub>8</sub> , $\overline{Q_8}$	Differential Outputs
V <sub>BB</sub>	V <sub>BB</sub> Output
V <sub>CCO</sub>	V <sub>CC</sub> to Output

**PACKAGE/ORDERING INFORMATION**

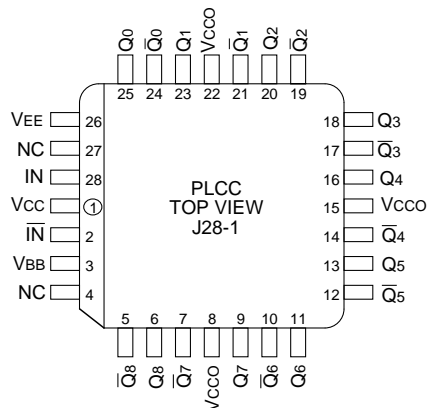

**28-Pin PLCC (J28-1)**

**Ordering Information<sup>(1)</sup>**

Part Number	Package Type	Operating Range	Package Marking	Lead Finish
SY10E111LJI	J28-1	Industrial	SY10E111LJI	Sn-Pb
SY10E111LJITR <sup>(2)</sup>	J28-1	Industrial	SY10E111LJI	Sn-Pb
SY100E111LJI	J28-1	Industrial	SY100E111LJI	Sn-Pb
SY100E111LJITR <sup>(2)</sup>	J28-1	Industrial	SY100E111LJI	Sn-Pb
SY10E111LJC	J28-1	Commercial	SY10E111LJC	Sn-Pb
SY10E111LJCTR <sup>(2)</sup>	J28-1	Commercial	SY10E111LJC	Sn-Pb
SY100E111LJC	J28-1	Commercial	SY100E111LJC	Sn-Pb
SY100E111LJCTR <sup>(2)</sup>	J28-1	Commercial	SY100E111LJC	Sn-Pb
SY10E111AJI	J28-1	Industrial	SY10E111AJI	Sn-Pb
SY10E111AJITR <sup>(2)</sup>	J28-1	Industrial	SY10E111AJI	Sn-Pb
SY100E111AJI	J28-1	Industrial	SY100E111AJI	Sn-Pb
SY100E111AJITR <sup>(2)</sup>	J28-1	Industrial	SY100E111AJI	Sn-Pb
SY10E111AJC	J28-1	Commercial	SY10E111AJC	Sn-Pb
SY10E111AJCTR <sup>(2)</sup>	J28-1	Commercial	SY10E111AJC	Sn-Pb
SY100E111AJC	J28-1	Commercial	SY100E111AJC	Sn-Pb
SY100E111AJCTR <sup>(2)</sup>	J28-1	Commercial	SY100E111AJC	Sn-Pb
SY10E111LJY <sup>(3)</sup>	J28-1	Industrial	SY10E111LJY with Pb-Free bar-line indicator	Matte-Sn
SY10E111LJYTR <sup>(2, 3)</sup>	J28-1	Industrial	SY10E111LJY with Pb-Free bar-line indicator	Matte-Sn
SY100E111LJY <sup>(3)</sup>	J28-1	Industrial	SY100E111LJY with Pb-Free bar-line indicator	Matte-Sn
SY100E111LJYTR <sup>(2, 3)</sup>	J28-1	Industrial	SY100E111LJY with Pb-Free bar-line indicator	Matte-Sn
SY10E111AJY <sup>(3)</sup>	J28-1	Industrial	SY10E111AJY with Pb-Free bar-line indicator	Matte-Sn
SY10E111AJYTR <sup>(2, 3)</sup>	J28-1	Industrial	SY10E111AJY with Pb-Free bar-line indicator	Matte-Sn
SY100E111AJY <sup>(3)</sup>	J28-1	Industrial	SY100E111AJY with Pb-Free bar-line indicator	Matte-Sn
SY100E111AJYTR <sup>(2, 3)</sup>	J28-1	Industrial	SY100E111AJY with Pb-Free bar-line indicator	Matte-Sn

**Notes:**

1. Contact factory for die availability. Dice are guaranteed at T<sub>A</sub> = 25°C, DC Electricals only.
2. Tape and Reel.
3. Pb-Free package is recommended for new designs.

**PRODUCT/PROCESS INFORMATION**

<b>Process:</b>	Bipolar
<b>ESD Rating:</b>	Per Mil Std. 883 Human Body Model, >1.5kV (all pins).

**ABSOLUTE MAXIMUM RATINGS<sup>(1)</sup>**

Symbol	Rating	Value	Unit
V <sub>CC</sub>	Power Supply Voltage (V <sub>EE</sub> = 0)	+6.0 to 0	V
V <sub>EE</sub>	Power Supply Voltage (V <sub>CC</sub> = 0)	-6.0 to 0	V
V <sub>IN</sub>	Input Voltage (V <sub>CC</sub> = 0V, V <sub>IN</sub> not more negative than V <sub>EE</sub> ) Input Voltage (V <sub>EE</sub> = 0V, V <sub>IN</sub> not more positive than V <sub>CC</sub> )	-6.0 to 0 +6.0 to 0	V V
I <sub>OUT</sub>	Output Current -Continuous -Surge	50 100	mA
T <sub>LEAD</sub>	Lead Storage Temperature Range (soldering, 20sec.)	+260	°C
T <sub>A</sub>	Operating Temperature Range	-40 to +85	°C
T <sub>store</sub>	Storage Temperature Range	-65 to +150	°C
θ <sub>JA</sub>	Thermal Resistance (Junction-to-Ambient) -Still Air	79	°C/W
θ <sub>JC</sub>	Thermal Resistance (Junction-to-Case)	24	°C/W
ESD	Mil Std. 883 Human Body Model, All Pins	>1.5k	V

**Note 1.** Permanent device damage may occur if absolute maximum ratings are exceeded. This is a stress rating only and functional operation is not implied at conditions other than those detailed in the operational sections of this data sheet. Exposure to absolute maximum rating conditions for extended periods may affect device reliability.

**ECL DC ELECTRICAL CHARACTERISTICS<sup>(1)</sup>**

V<sub>EE</sub> = V<sub>EE</sub> (Min.) to V<sub>EE</sub> (Max.); V<sub>CC</sub> = GND

Symbol	Parameter	T <sub>A</sub> = -40°C			T <sub>A</sub> = 0°C			T <sub>A</sub> = +25°C			T <sub>A</sub> = +85°C			Unit
		Min.	Typ.	Max.	Min.	Typ.	Max.	Min.	Typ.	Max.	Min.	Typ.	Max.	
V <sub>OH</sub>	Output HIGH Voltage													mV
	10EL	-1080	—	-890	-1020	—	-840	-980	—	-810	-910	—	-720	
	100EL	-1085	—	-880	-1025	—	-880	-1025	—	-880	-1025	—	-880	
V <sub>OL</sub>	Output LOW Voltage													mV
	10EL	-1950	—	-1650	-1950	—	-1630	-1950	—	-1630	-1950	—	-1595	
	100EL	-1830	—	-1550	-1810	—	-1620	-1810	—	-1620	-1810	—	-1620	
V <sub>IH</sub>	Input HIGH Voltage													mV
	10EL	-1230	—	-890	-1170	—	-840	-1130	—	-810	-1060	—	-720	
	100EL	-1165	—	-880	-1165	—	-880	-1165	—	-880	-1165	—	-880	
V <sub>IL</sub>	Input LOW Voltage													mV
	10EL	-1950	—	-1500	-1950	—	-1480	-1950	—	-1480	-1950	—	-1445	
	100EL	-1810	—	-1475	-1810	—	-1475	-1810	—	-1475	-1810	—	-1475	
V <sub>BB</sub>	Output Reference Voltage													V
	10EL	-1.43	—	-1.30	-1.38	—	-1.27	-1.35	—	-1.25	-1.31	—	-1.19	
	100EL	-1.38	—	-1.26	-1.38	—	-1.26	-1.38	—	-1.26	-1.38	—	-1.26	
I <sub>IH</sub>	Input HIGH Current	—	—	150	—	—	150	—	—	150	—	—	150	μA
I <sub>IL</sub>	Input LOW Current													μA
	10EL	0.5	—	—	0.5	—	—	0.5	—	—	0.3	—	—	
	100EL	0.5	—	—	0.5	—	—	0.5	—	—	0.5	—	—	
I <sub>EE</sub>	Power Supply Current													mA
	10EL	35	—	65	35	—	65	35	—	65	35	—	65	
	100EL	35	—	65	35	—	65	35	—	65	35	—	75	

**Note 1.** Parametric values specified at: 5 volt Power Supply Range 100E111A Series: -4.2V to -5.5V.  
10E111A Series -4.75V to -5.5V.  
3 volt Power Supply Range 10/100E111L Series: -3.0V to -3.8V.

**3.3V PECL DC ELECTRICAL CHARACTERISTICS(1)**

V<sub>CC</sub> = +3.0V to +3.8V, V<sub>EE</sub> = GND

Symbol	Parameter	TA = -40°C			TA = 0°C			TA = +25°C			TA = +85°C			Unit
		Min.	Typ.	Max.	Min.	Typ.	Max.	Min.	Typ.	Max.	Min.	Typ.	Max.	
V <sub>OH</sub>	Output HIGH Voltage													mV
	<b>Note 2</b>													
	10EL	2220	—	2110	2280	—	2460	2320	—	2490	2390	—	2580	
100EL	2215	—	2120	2275	—	2420	2275	—	2420	2275	—	2420		
V <sub>OL</sub>	Output LOW Voltage													mV
	<b>Note 2</b>													
	10EL	1350	—	1650	1350	—	1670	1350	—	1670	1350	—	1705	
100EL	1470	—	1750	1490	—	1680	1490	—	1680	1490	—	1680		
V <sub>IH</sub>	Input HIGH Voltage													mV
	<b>Note 2</b>													
	10EL	2070	—	2410	2130	—	2460	2170	—	2490	2240	—	2580	
100EL	2135	—	2420	2135	—	2420	2135	—	2420	2135	—	2420		
V <sub>IL</sub>	Input LOW Voltage													mV
	<b>Note 2</b>													
	10EL	1350	—	1800	1350	—	1820	1350	—	1820	1350	—	1855	
100EL	1490	—	1825	1490	—	1825	1490	—	1825	1490	—	1825		
V <sub>BB</sub>	Output Reference Voltage, <b>Note 2</b>													V
	10EL	1.87	—	2.00	1.92	—	2.03	1.95	—	2.05	1.99	—	2.11	
	100EL	1.92	—	2.04	1.92	—	2.04	1.92	—	2.04	1.92	—	2.04	
I <sub>IH</sub>	Input HIGH Current	—	—	150	—	—	150	—	—	150	—	—	150	μA
I <sub>IL</sub>	Input LOW Current													μA
	10EL	0.5	—	—	0.5	—	—	0.5	—	—	0.3	—	—	
	100EL	0.5	—	—	0.5	—	—	0.5	—	—	0.5	—	—	
I <sub>EE</sub>	Power Supply Current													mA
	10EL	—	—	66	—	—	66	—	—	66	—	—	66	
	100EL	—	—	66	—	—	66	—	—	66	—	—	78	

**Note 1.** Parametric values specified at: 3 volt Power Supply Range 10/100E111L Series: +3.0V to +3.8V.

**Note 2.** These values are for V<sub>CC</sub> = 3.3V. Level specifications will vary 1:1 with V<sub>CC</sub>.

**5V PECL DC ELECTRICAL CHARACTERISTICS(1)**

V<sub>CC</sub> = V<sub>CC</sub> (Min.) to V<sub>CC</sub> (Max.); V<sub>EE</sub> = GND

Symbol	Parameter	TA = -40°C			TA = 0°C			TA = +25°C			TA = +85°C			Unit
		Min.	Typ.	Max.	Min.	Typ.	Max.	Min.	Typ.	Max.	Min.	Typ.	Max.	
V <sub>OH</sub>	Output HIGH Voltage													mV
	<b>Note 2</b>													
	10EL	3920	—	4110	3980	—	4160	4020	—	4190	4090	—	4280	
100EL	3915	—	4120	3975	—	4120	3975	—	4120	3975	—	4120		
V <sub>OL</sub>	Output LOW Voltage													mV
	<b>Note 2</b>													
	10EL	3050	—	3350	3050	—	3370	3050	—	3370	3050	—	3405	
100EL	3170	—	3450	3190	—	3380	3190	—	3380	3190	—	3380		
V <sub>IH</sub>	Input HIGH Voltage													mV
	<b>Note 2</b>													
	10EL	3770	—	4110	3830	—	4160	3870	—	4190	3940	—	4280	
100EL	3835	—	4120	3835	—	4120	3835	—	4120	3835	—	4120		
V <sub>IL</sub>	Input LOW Voltage													mV
	<b>Note 2</b>													
	10EL	3050	—	3500	3050	—	3520	3050	—	3520	3050	—	3555	
100EL	3190	—	3525	3190	—	3525	3190	—	3525	3190	—	3525		
V <sub>BB</sub>	Output Reference Voltage, <b>Note 2</b>													V
	10EL	3.57	—	3.70	3.62	—	3.73	3.65	—	3.75	3.69	—	3.81	
	100EL	3.62	—	3.74	3.62	—	3.74	3.62	—	3.74	3.62	—	3.74	
I <sub>IH</sub>	Input HIGH Current	—	—	150	—	—	150	—	—	150	—	—	150	μA
I <sub>IL</sub>	Input LOW Current													μA
	10EL	0.5	—	—	0.5	—	—	0.5	—	—	0.3	—	—	
	100EL	0.5	—	—	0.5	—	—	0.5	—	—	0.5	—	—	
I <sub>EE</sub>	Power Supply Current													mA
	10EL	—	—	66	—	—	66	—	—	66	—	—	66	
	100EL	—	—	66	—	—	66	—	—	66	—	—	78	

**Note 1.** Parametric values specified at: 5 volt Power Supply Range 100E111A Series: +4.2V to +5.5V.

10E111A Series +4.75V to +5.5V.

**Note 2.** These values are for V<sub>CC</sub> = 5V. Level specifications will vary 1:1 with V<sub>CC</sub>.



**28-PIN PLCC (J28-1)**

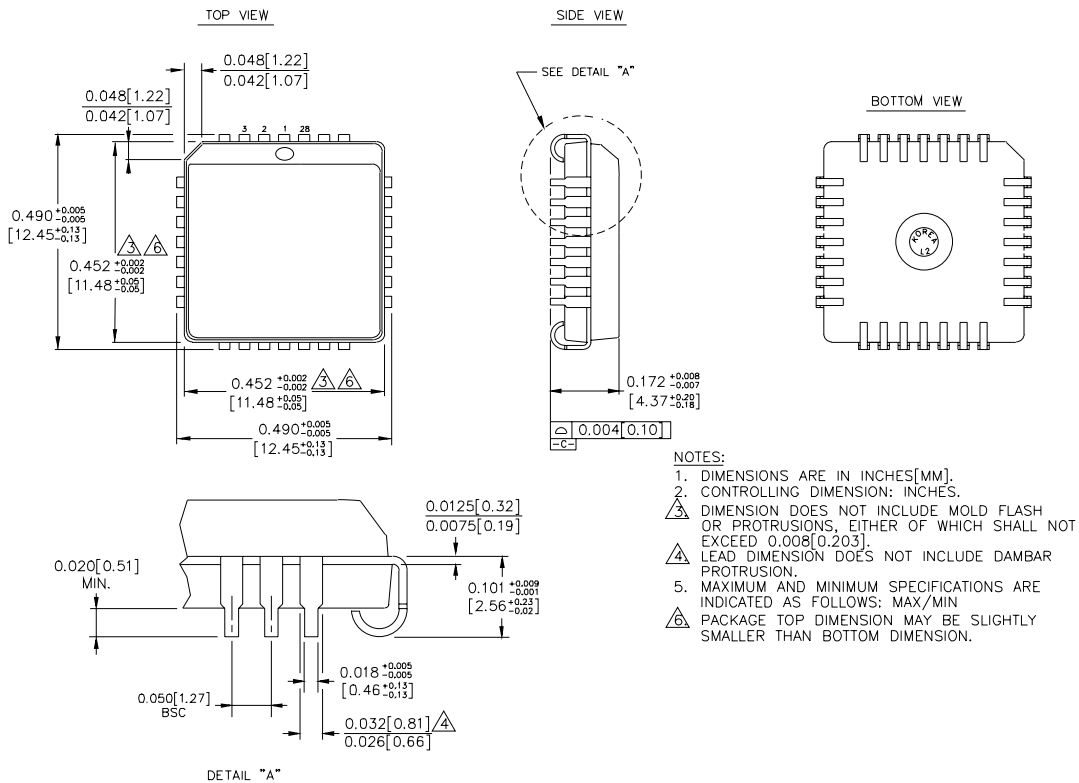

Rev. 03

**Package Notes:**

**Note 1.** Package meets Level 1 moisture sensitivity.

**MICREL, INC. 2180 FORTUNE DRIVE SAN JOSE, CA 95131 USA**

TEL + 1 (408) 944-0800 FAX + 1 (408) 474-1000 WEB <http://www.micrel.com>

The information furnished by Micrel in this datasheet is believed to be accurate and reliable. However, no responsibility is assumed by Micrel for its use. Micrel reserves the right to change circuitry and specifications at any time without notification to the customer.

Micrel Products are not designed or authorized for use as components in life support appliances, devices or systems where malfunction of a product can reasonably be expected to result in personal injury. Life support devices or systems are devices or systems that (a) are intended for surgical implant into the body or (b) support or sustain life, and whose failure to perform can be reasonably expected to result in a significant injury to the user. A Purchaser's use or sale of Micrel Products for use in life support appliances, devices or systems is at Purchaser's own risk and Purchaser agrees to fully indemnify Micrel for any damages resulting from such use or sale.

© 2006 Micrel, Incorporated.

## X-ON Electronics

Largest Supplier of Electrical and Electronic Components

*Click to view similar products for [Clock Buffer](#) category:*

*Click to view products by [Microchip](#) manufacturer:*

Other Similar products are found below :

[PL133-27GI](#) [9DBV0541AKLF](#) [9DBV0941AKLF](#) [MPC962309EJ-1H](#) [NB3M8304CDG](#) [NB4N121KMNG](#) [NB7VQ58MMNG](#)  
[8T39S11ANLGI](#) [8T73S1802NLGI](#) [9DBV0941AKILF](#) [MC10E111FNG](#) [MK2308S-1HILF](#) [5PB1216NDGK](#) [6V31024NLG](#) [PL133-27GI-R](#)  
[9DBV0941AKILFT](#) [NB3L02FCT2G](#) [NB3L03FCT2G](#) [NB7VQ58MMNHTBG](#) [ZL40203LDG1](#) [ZL40200LDG1](#) [9DMV0141AKILFT](#)  
[ZL40205LDG1](#) [ZL40201LDG1](#) [9DBV0541AKILF](#) [PI49FCT32807QE](#) [552-02SPGGI](#) [9FG1200DF-1LF](#) [MDB1900ZCQY](#) [9ZXL1530DKILF](#)  
[8SLVP1102ANLGI/W](#) [ZL40223LDG1](#) [5PB1203NTGK8](#) [9FG1001BGLF](#) [MDB1900ZBQY](#) [5PB1213NTGK](#) [5PB1214CMGK](#)  
[ZL40202LDG1](#) [8L30205NLGI8](#) [5PB1204CMGK](#) [5PB1214CMGK8](#) [5PB1203NTGK](#) [5PB1206NDGK](#) [PI49FCT20802QE](#) [MAX9317AECJ+](#)  
[SL2305SC-1T](#) [PI6C10810HE](#) [5P1103A517NLGI](#) [9ZX21901DKLF](#) [NB7L1008MNG](#)