



STMPE16M31 STMPE24M31

S-Touch[®] 16/24-channel touchkey controller with PWM and ratio engines

Features

- Up to 24 capacitive sensor inputs
- Independent and configurable automatic calibration on all channels
- 15 fF resolution, 512 steps with 30 pF auto-tuning
- Up to 30 pF external reference capacitor
- 2 units of 8-input ratiometric engines supporting 256 steps slider/wheel
- PWM and GPIO:
 - Up to 16 general purpose inputs/outputs
 - 8 independent PWM controllers, up to 16 PWM outputs
 - 12 mA sourcing/sinking on GPIO for LED driving (at 3.3 V V_{IO})
 - Maximum source/sink current 120 mA
- Operating voltage:
 - 1.65 - 1.95 V (V_{CC} , internally supplied)
 - 2.7- 5.5 V (V_{IO})
- Low operating current: 400 μ A in active mode, 50 μ A in sleep mode and 5 μ A in hibernate mode
- I²C interface (up to 400 kHz). I²C is 3.3 V tolerant
- 8 kV HBM ESD protection on all sensing pins
- 200V MM ESD protection on all pins

Applications

- Multimedia bars in notebook computers
- Portable media players and game consoles
- Mobile phones and smartphones

Table 1. Device summary

| Order code | Package | Packaging |
|---------------|------------------|---------------|
| STMPE24M31QTR | QFN40 (5 x 5 mm) | Tape and reel |
| STMPE16M31QTR | QFN32 (4 x 4 mm) | Tape and reel |

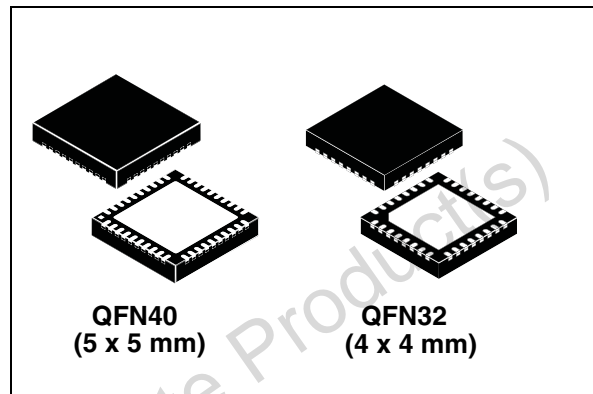

Description

The STMPE16M31 and STMPE24M31 capacitive touchkey controllers offer highly versatile and flexible capacitive sensing capabilities in one single chip.

The devices integrate up to 24 capacitive sensing channels which are highly sensitive and noise tolerant. Two units of hardwired ratiometric engines enable the implementation of a slider/wheel without external computations. Eight independent PWM controllers allow to control up to 16 LEDs with brightness control, ramping and blinking capabilities. The I²C interface supports up to 400 kHz communication with the system host. A very wide dynamic range allows most applications to work without hardware tuning.

A single STMPE24M31 device can be used to implement a complete notebook multimedia control bar with eight capacitive touchkeys, an 8-channel slider with 256 steps resolution and eight independently controlled LED.

Contents

| | | |
|-----------|--|-----------|
| 1 | Pin assignment | 4 |
| 1.1 | Power scheme | 9 |
| 1.2 | Power states | 9 |
| 2 | I²C interface module | 11 |
| 2.1 | Device operation | 11 |
| 3 | Read operations | 15 |
| 4 | Write operations | 16 |
| 4.1 | Write operations for one or more bytes | 16 |
| 5 | General call address | 17 |
| 6 | Register map and function description | 18 |
| 7 | System controller | 22 |
| 7.1 | Interrupt system | 25 |
| 8 | Interrupt service routine | 32 |
| 9 | GPIO controller | 33 |
| 10 | PWM array controller | 37 |
| 11 | PWM controller | 39 |
| 11.1 | PWM function register map | 39 |
| 12 | Basic PWM programming | 45 |
| 12.1 | Interrupt on basic PWM controller | 47 |
| 13 | Touch sensor controller | 48 |
| 13.1 | Sampling rate calculation | 49 |
| 13.2 | Sensor resolution | 49 |

| | | |
|-----------|---|-----------|
| 13.3 | Auto-tuning | 50 |
| 13.4 | Locked impedance | 51 |
| 13.5 | Calibration | 51 |
| 13.6 | Definition of data accessible through channel data register | 59 |
| 13.7 | Ratiometric engine | 60 |
| 14 | Touchkey controller | 66 |
| 15 | Maximum rating | 71 |
| 15.1 | Recommended operating conditions | 71 |
| 16 | Application information | 72 |
| 16.1 | Average current consumption | 72 |
| 17 | DC electrical characteristics | 73 |
| 17.1 | Capacitive sensor specification | 74 |
| 18 | Package mechanical data | 75 |
| 19 | Revision history | 84 |

Obsolete Product(s) - Obsolete Product(s)

1 Pin assignment

Figure 1. STMPE24M31 pin out

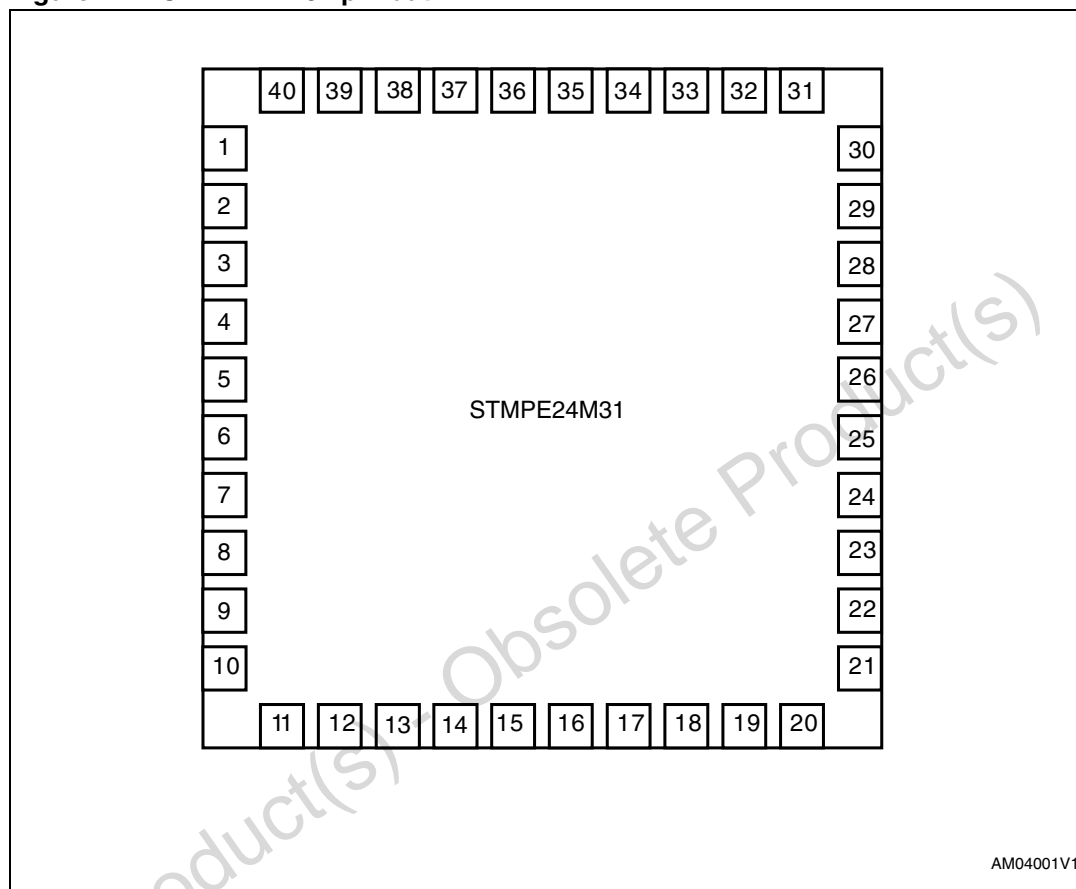

Figure 2. STMPE16M31 pin out

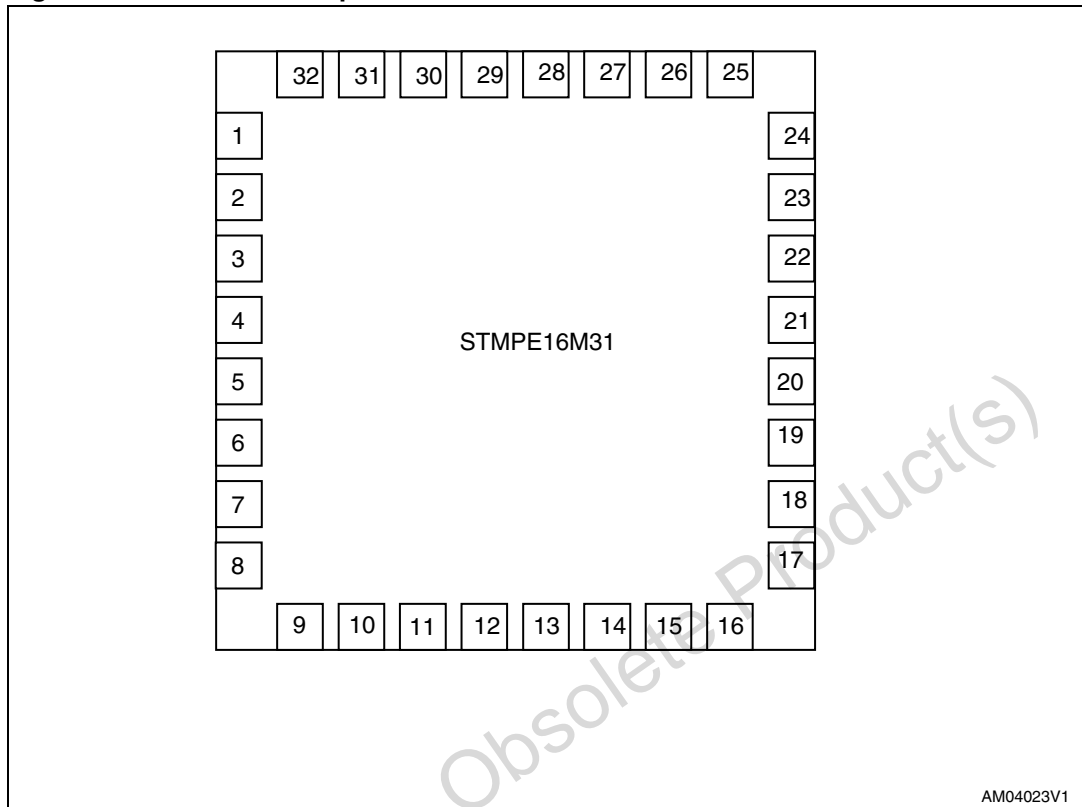

Table 2. STMPE16M31 and STMPE24M31 pin description

| STMPE24M31 pin number | STMPE16M31 pin number | Pin name | Voltage domain | Description |
|-----------------------|-----------------------|----------|----------------|-------------------------|
| 1 | 1 | GPIO-0 | VIO | GPIO / capacitive sense |
| 2 | 2 | GPIO-1 | VIO | GPIO / capacitive sense |
| 3 | 3 | GPIO-2 | VIO | GPIO / capacitive sense |
| 4 | 4 | GND | - | Ground |
| 5 | 5 | VIO | - | I/O supply |
| 6 | - | CAP-16 | VCC | Capacitive sense |
| 7 | - | CAP-17 | VCC | Capacitive sense |
| 8 | 6 | GPIO-3 | VIO | GPIO / capacitive sense |
| 9 | 7 | GPIO-4 | VIO | GPIO / capacitive sense |
| 10 | 8 | GPIO-5 | VIO | GPIO / capacitive sense |
| 11 | 9 | GPIO-6 | VIO | GPIO / capacitive sense |
| 12 | 10 | GPIO-7 | VIO | GPIO / capacitive sense |
| 13 | 11 | GND | - | Ground |
| 14 | 12 | VIO | - | I/O supply |

Table 2. STMPE16M31 and STMPE24M31 pin description (continued)

| STMPE24M31 Pin number | STMPE16M31 Pin number | Pin name | Voltage domain | Description |
|--------------------------|--------------------------|-----------|----------------|--|
| 15 | - | CAP-18 | VCC | Capacitive sense |
| 16 | - | CAP-19 | VCC | Capacitive sense |
| 17 | 13 | VCC | - | |
| 18 | 14 | INT | VCC | Open drain interrupt output. This pin should be pulled to VCC or GND, depending on polarity of interrupt used. This pin must not be left floating. |
| 19 | 15 | Address 0 | VCC | I ² C address 0 |
| 20 | 16 | SCL | VCC | I ² C clock |
| 21 | 17 | SDA | VCC | I ² C data |
| 22 | 18 | RESET_N | VCC | Active low reset signal |
| 23 | 19 | Address 1 | VCC | I ² C address 1 |
| 24 | 20 | CRef | VCC | Reference capacitor |
| 25 | - | CAP-20 | VCC | Capacitive sense (minimum 10 pF capacitor is recommended) |
| 26 | - | CAP-21 | VCC | Capacitive sense |
| 27 | 21 | GND | VCC | Ground |
| 28 | 22 | GPIO-8 | VIO | GPIO / capacitive sense |
| 29 | 23 | GPIO-9 | VIO | GPIO / capacitive sense |
| 30 | 24 | VIO | - | I/O supply |
| 31 | 25 | GPIO-10 | VIO | GPIO / capacitive sense |
| 32 | 26 | GPIO-11 | VIO | GPIO / capacitive sense |
| 33 | 27 | GPIO-12 | VIO | GPIO / capacitive sense |
| 34 | 28 | GPIO-13 | VIO | GPIO / capacitive sense |
| 35 | 29 | VIO | - | I/O supply |
| 36 | 30 | GND | - | I/O voltage supply |
| 37 | - | CAP-22 | VCC | Capacitive sense |
| 38 | - | CAP-23 | VCC | Capacitive sense |
| 39 | 31 | GPIO-14 | VIO | GPIO / capacitive sense |
| 40 | 32 | GPIO-15 | VIO | GPIO / capacitive sense |

Figure 3. STMPE16M31 and STMPE24M31 block diagram

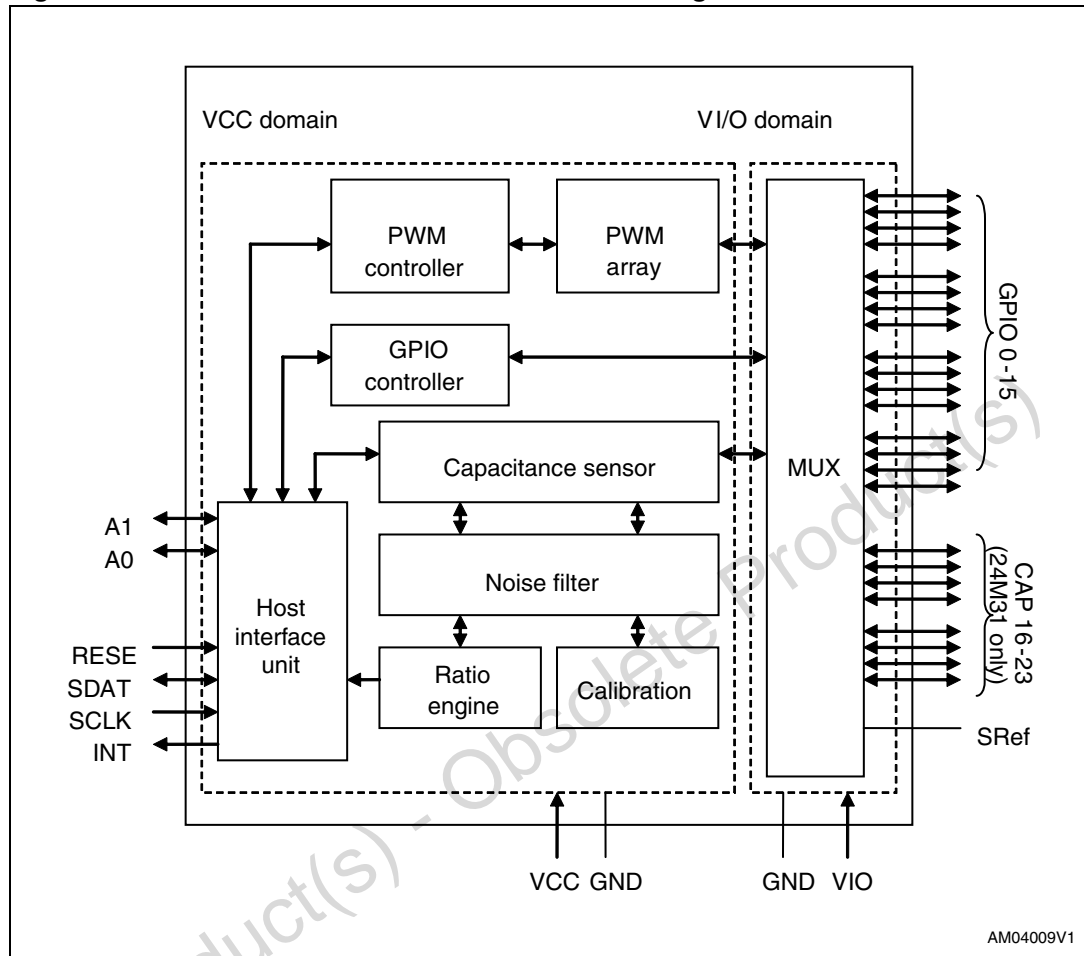

Obsolete Product(s)

Figure 4. Sample application - notebook multimedia bar

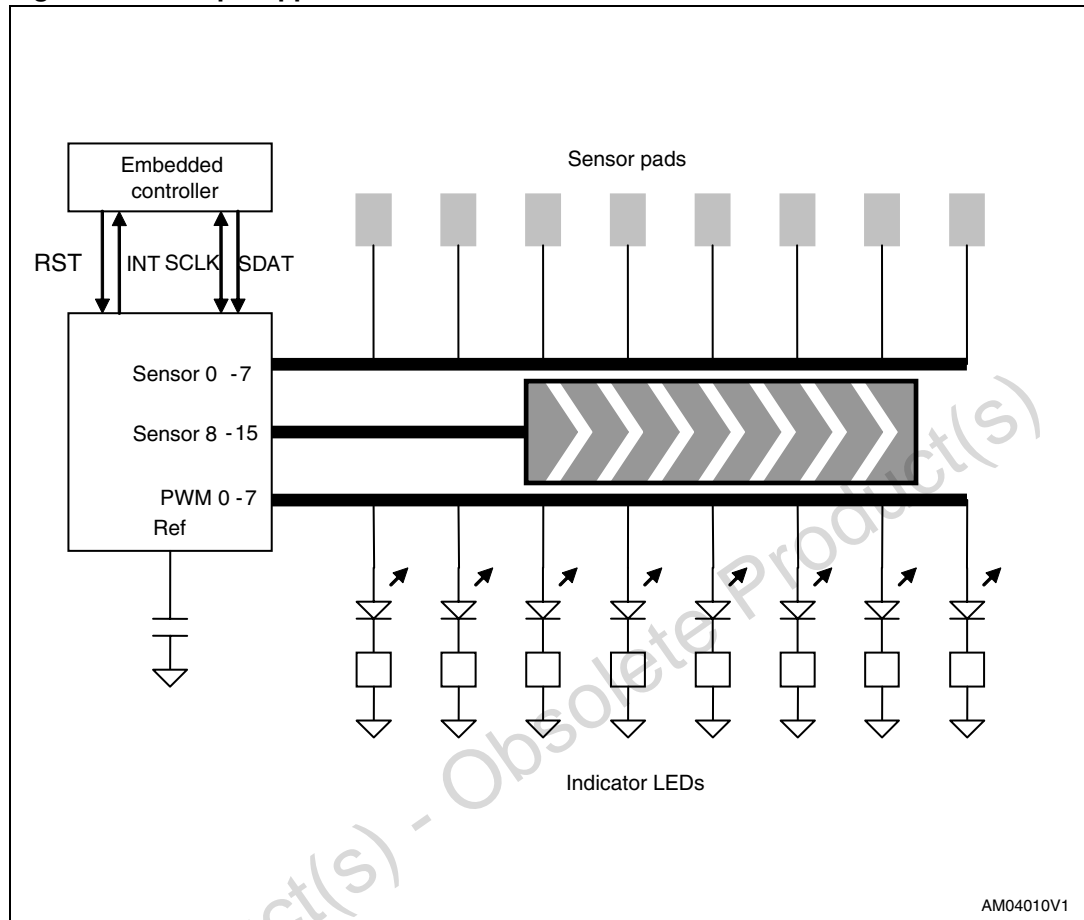

Table 3. Limitations on intrinsic capacitance on PCB / flexi PCB⁽¹⁾

| C _{max} -C _{min} (Difference between highest and lowest channel capacitance) | C _{max} | Matching capacitors |
|---|------------------|--|
| < 30 pF | < 30 pF | Not required |
| < 30 pF | > 30 pF, < 60 pF | C _{ref} of up to 30 pF required |
| > 30 pF, < 60 pF | > 30 pF, < 60 pF | C _{ref} of up to 30 pF required Channel matching capacitance of up to 25 pF required |
| > 60 pF | > 60 pF | PCB optimization required |

1. For small PCBs, it is possible to operate the device with C_{Ref} left unconnected. However, without a small capacitance at this pin, the capacitive sensing operation tends to be noisier. It is recommended that a capacitor of 10 pF to be connected to this pin.

1.1 Power scheme

The STMPE24M31/16M31 is powered by a 2.7- 5.5 V supply. An internal voltage regulator regulates this supply into 1.8 V for core operation. It is recommended to connect a 1 μ F capacitor at V_{CC} pin for filtering purpose. The V_{IO} powers all GPIOs directly, if any LED driving is required on the GPIO, the V_{IO} should be at least 3.3 V.

Figure 5. Power supply scheme

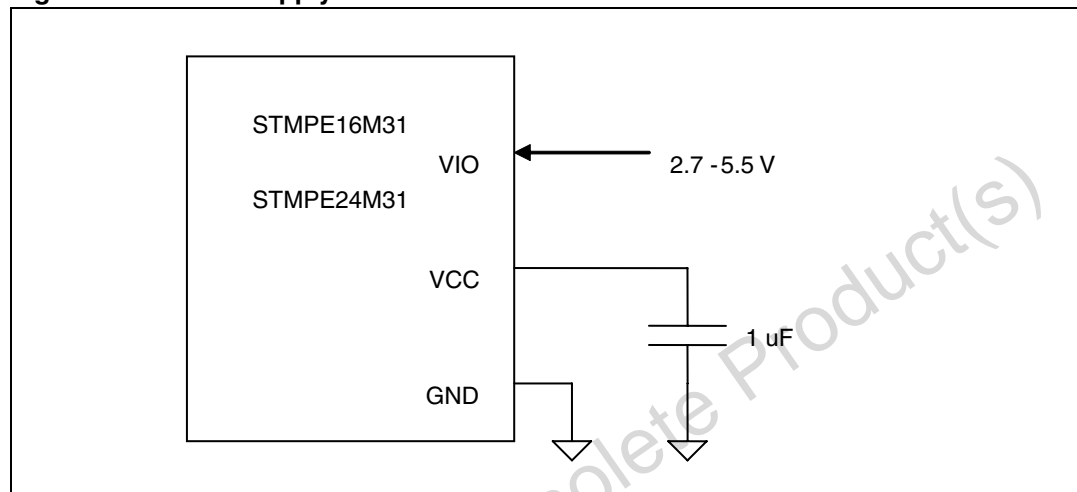

1.2 Power states

The STMPE24M31/16M31 operate in 3 states. [Table 4](#) illustrates the capability of the device in each of the power states.

Figure 6. Power states

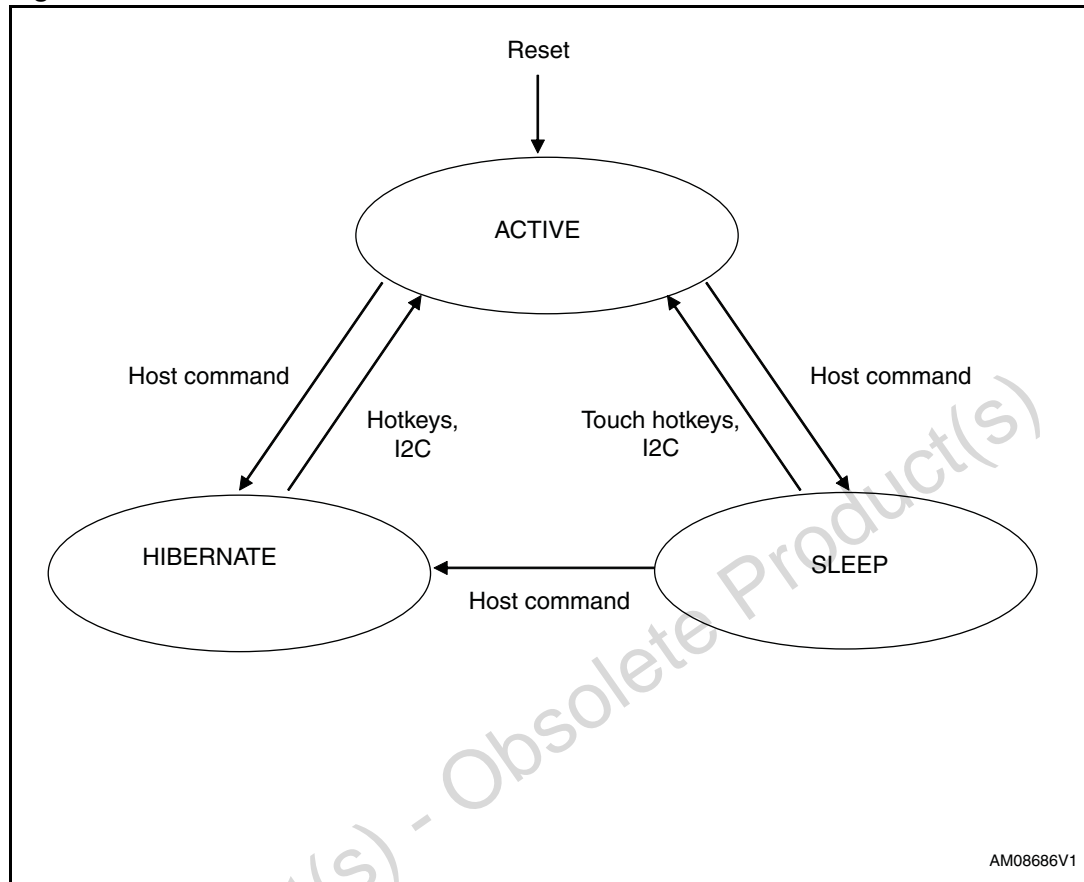

AM08686V1

1. STMPExxM31 remains in active mode when PWM is running.

Table 4. Functions available in each power state

| | Hibernate | Sleep | Active |
|--------------------|-----------|-------------------|--------|
| I ² C | Yes | Yes | Yes |
| GPIO hotkey | Yes | Yes | Yes |
| PWM | No | Yes | Yes |
| Capacitive sensing | No | Slow | Yes |
| Ratio engine | No | No ⁽¹⁾ | Yes |

1. When the ratio engine is enabled, device transitions to active state whenever a touch on the slider/wheel is detected, even if it was previously in sleep mode.

2 I²C interface module

The STMPE24M31/16M31 has 2 physical I²C address pins, allowing 4 different I²C address settings.

Table 5. I²C address pins

| Address 1 | Address 0 | I ² C address |
|-----------|-----------|--------------------------|
| 0 | 0 | 0x58 |
| 0 | 1 | 0x59 |
| 1 | 0 | 0x5A |
| 1 | 1 | 0x5B |

The features that are supported by the I²C interface module are the following ones:

- I²C slave device
- Operates at V_{CC} (tolerant to 3.3 V signaling)
- Compliant to Philips I²C specification version 2.1
- Supports standard (up to 100 kbps) and fast (up to 400 kbps) modes
- 7-bit and 10-bit device addressing modes
- General call
- Start/restart/stop

The features that are not supported are:

- Hardware general call
- CBUS compatibility
- High-speed (3.4 Mbps) mode

2.1 Device operation

Start condition

A Start condition is identified by a falling edge of SDA while SCL is stable at high state. A Start condition must precede any data/command transfer. The device continuously monitors for a Start condition and does not respond to any transaction unless one is encountered.

Stop condition

A Stop condition is identified by a rising edge of SDA while SCL is stable at high state. A Stop condition terminates the communication between the slave device and bus master. A read command that is followed by NoAck can be followed by a Stop condition to force the slave device into idle mode. When the slave device is in idle mode, it is ready to receive the next I²C transaction. A Stop condition at the end of a write command stops the write operation to registers.

Acknowledge bit (ACK)

The acknowledge bit is used to indicate a successful byte transfer. The bus transmitter releases the SDA after sending eight bits of data. During the ninth bit, the receiver pulls the SDA low to acknowledge the receipt of the eight bits of data. The receiver may leave the SDA in high state if it would to *not* acknowledge the receipt of the data.

Data input

The device samples the data input on SDA on the rising edge of the SCL. The SDA signal must be stable during the rising edge of SCL and the SDA signal must change only when SCL is driven low.

Memory addressing

For the bus master to communicate to the slave device, the bus master must initiate a Start condition and be followed by the slave device address. Accompanying the slave device address, there is a Read/ \bar{W} bit (R/\bar{W}). The bit is set to 1 for Read and 0 for Write operation.

If a match occurs on the slave device address, the corresponding device gives an acknowledgement on the SDA during the 9th bit time. If there is no match, it deselects itself from the bus by not responding to the transaction. The register memory map of the device is 8-bit address width. Therefore, the maximum number of register is 256 registers of 8-bit width.

[Table 6](#) illustrates the device operating modes that are supported.

Table 6. Device operation modes

| Mode | Bytes | Initial sequence |
|-------|-------|--|
| Read | ≥1 | START, Device Address, R/\bar{W} =0, Base register Address to be read |
| | | ReSTART, Device Address, R/\bar{W} =1, Data Read, STOP |
| | | If no STOP is issued, the Data Read can be continuously performed. The address is automatically incremented on subsequent data read. |
| Write | ≥1 | START, Device Address, R/\bar{W} =0, Register Address to be written, Data Write, STOP |
| | | If no STOP is issued, the Data Write can be continuously performed. The address is automatically incremented on subsequent write. |

Figure 7. Read and write modes (random and sequential)

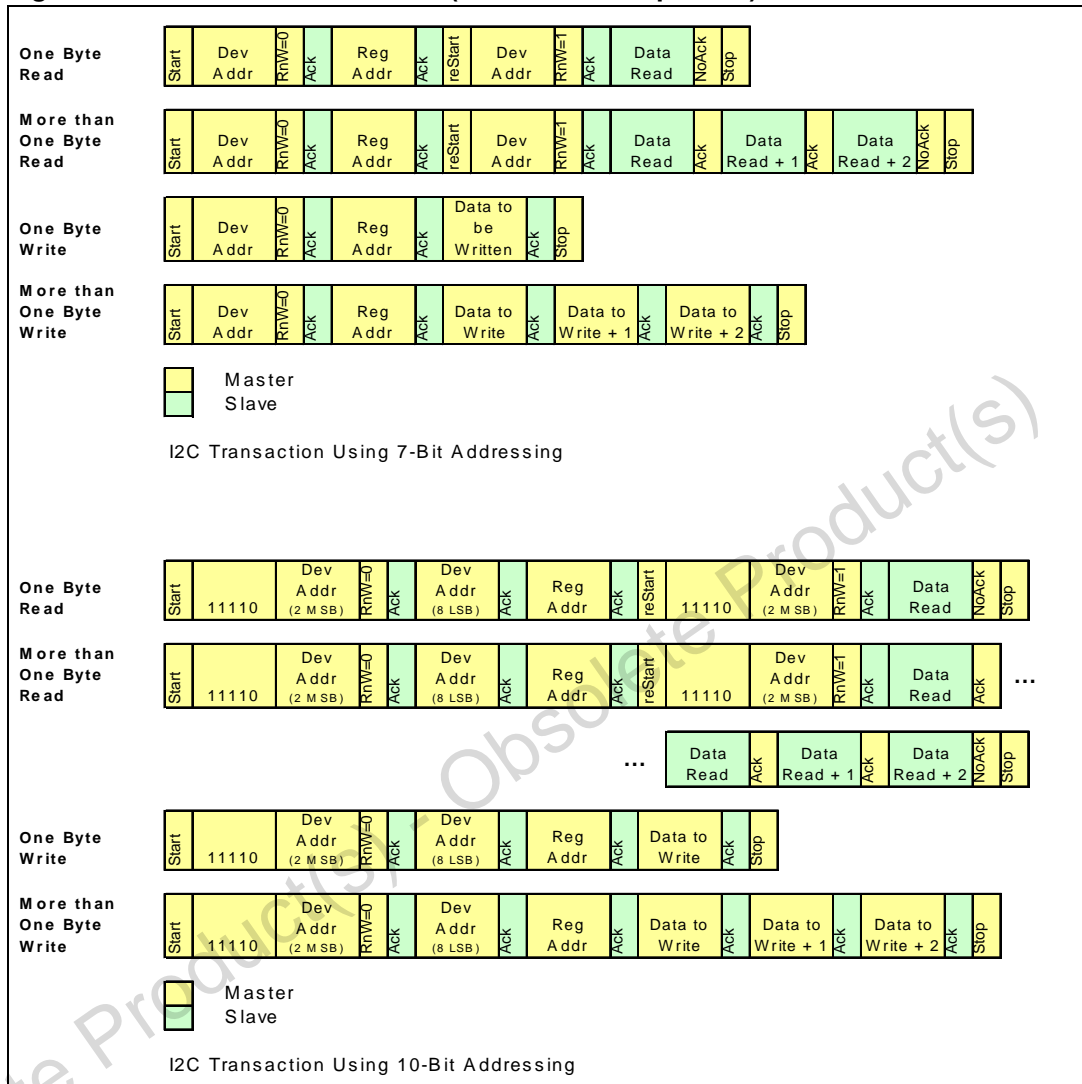
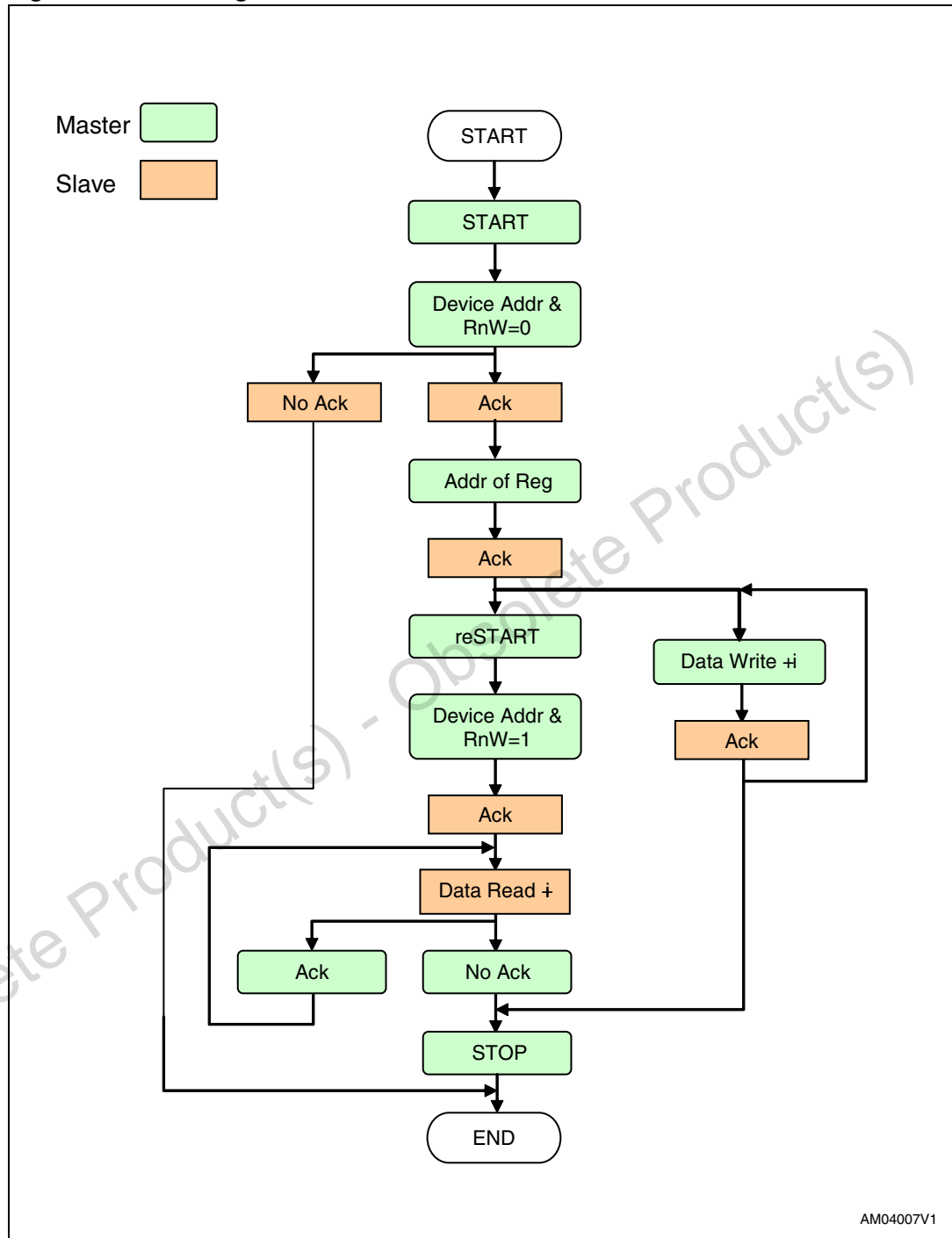

Figure 8. Flow diagram for read and write modes



3 Read operations

Read operations for one or more bytes

A write is first performed to load the base register address into the address counter but without sending a Stop condition. Then, the bus master sends a reStart condition and repeats the Device Address with the R/W bit set to 1. The slave device acknowledges and outputs the content of the addressed byte. If no more data is to be read, the bus master must not acknowledge the byte and terminates the transfer with a Stop condition.

If the bus master acknowledges the data byte, then it can continue to perform the data reading. To terminate the stream of data byte, the bus master must not acknowledge the last output byte and follow by a Stop condition. The data fetched are from consecutive addresses. After the last memory address, the Address Counter 'rolls-over' and the device continue to output data from the memory address of 0x00.

Acknowledgement in read operation

For the above read command, the slave device waits, after each byte read, for an acknowledgement during the 9th bit time. If the bus master does not drive the SDA to low state (no acknowledgement by the master), then the slave device terminates and switches back to its idle mode, waiting for the next command.

4 Write operations

4.1 Write operations for one or more bytes

A write is first performed to load the base register address into the Address Counter without sending a Stop condition. After the bus master receives an acknowledgement from the slave device, it may start to send a data byte to the register (pointed by the Address Counter). The slave device again acknowledges and the bus master terminates the transfer with a Stop condition.

If the bus master would like to continue to write more data, it can just continue write operation without issuing the Stop condition. After the bus master writes the last data byte and the slave device acknowledges the receipt of the last data, the bus master may terminate the write operation by sending a Stop condition. When the Address Counter reaches the last memory address, it 'rolls-over' on the next data byte write.

5 General call address

A general call address is a transaction with the slave address of 0x00 and $R/\overline{W} = 0$. When a general call address is made, the GPIO expander responds to this transaction with an acknowledgement and behaves as a slave-receiver mode. The meaning of a general call address is defined in the second byte sent by the master-transmitter.

Table 7. Definition of the second byte of the I²C transaction

| R/ \overline{W} | Second byte value | Definition |
|-------------------|-------------------|--|
| 0 | 0x06 | 2-byte transaction in which the second byte tells the slave device to perform a soft reset and write (or latch in) the 2-bit programmable part of the slave address. |
| 0 | 0x04 | 2-byte transaction in which the second byte tells the slave device not to perform a soft reset and write (or latch in) the 2-bit programmable part of the slave address. |
| 0 | 0x00 | Not allowed as second byte. |

Note: All other second byte values will be ignored.

Note: Please allow a gap of approximately 2 μ s gap before the next I2C transaction after the General Call of 0x04 or 0x06.

6 Register map and function description

This section lists and describes the registers of the STMPE16M31 and STMPE24M31 devices, starting with a register map and then provides detailed descriptions of register types.

Table 8. Register map

| Address | Register name | Reset value | I ² C | Register function |
|---------|----------------|-------------|------------------|--|
| 0x00 | CHIP_ID | 0x2431 | R | CHIP identification number MSB: 0x24, LSB: 0x31 |
| 0x02 | ID_VER | 0x03 | R | Version of device Engineering samples: 0x01, 0x02 Final silicon: 0x03 |
| 0x03 | SYSCON-1 | 0x00 | RW | General system control |
| 0x04 | SYSCON-2 | 0xFE | RW | Sensor and PWM clock divider |
| 0x06 | INT_CTRL | 0x00 | RW | Interrupt control |
| 0x08 | INT_STA | 0x00 | RW | Interrupt status |
| 0x09 | INT_EN | 0x00 | RW | Interrupt enable |
| 0x0A | GPIO_INT_STA | 0x0000 | RW | Interrupt status GPIO |
| 0x0C | GPIO_INT_EN | 0x0000 | RW | Interrupt enable GPIO |
| 0x0E | PWM_INT_STA | 0x00 | RW | Interrupt status PWM |
| 0x0F | PWM_INT_EN | 0x00 | RW | Interrupt enable PWM |
| 0x10 | GPIO_DIR | 0x0000 | RW | GPIO direction setting |
| 0x12 | GPIO_MP_STA | 0x0000 | R | GPIO pin state monitor |
| 0x14 | GPIO_SET_PIN | 0x0000 | RW | GPIO set pin state |
| 0x16 | GPIO_ALT_FUN | 0x0000 | RW | GPIO alternate function |
| 0x20 | GPIO_0_PWM_CFG | 0x00 | RW | Configures PWM output of GPIO-0 |
| 0x21 | GPIO_1_PWM_CFG | 0x00 | RW | Configures PWM output of GPIO-1 |
| 0x22 | GPIO_2_PWM_CFG | 0x00 | RW | Configures PWM output of GPIO-2 |
| 0x23 | GPIO_3_PWM_CFG | 0x00 | RW | Configures PWM output of GPIO-3 |
| 0x24 | GPIO_4_PWM_CFG | 0x00 | RW | Configures PWM output of GPIO-4 |
| 0x25 | GPIO_5_PWM_CFG | 0x00 | RW | Configures PWM output of GPIO-5 |
| 0x26 | GPIO_6_PWM_CFG | 0x00 | RW | Configures PWM output of GPIO-6 |

Table 8. Register map (continued)

| Address | Register name | Reset value | I ² C | Register function |
|---------|-----------------|-------------|------------------|----------------------------------|
| 0x27 | GPIO_7_PWM_CFG | 0x00 | RW | Configures PWM output of GPIO-7 |
| 0x28 | GPIO_8_PWM_CFG | 0x00 | RW | Configures PWM output of GPIO-8 |
| 0x29 | GPIO_9_PWM_CFG | 0x00 | RW | Configures PWM output of GPIO-9 |
| 0x2A | GPIO_10_PWM_CFG | 0x00 | RW | Configures PWM output of GPIO-10 |
| 0x2B | GPIO_11_PWM_CFG | 0x00 | RW | Configures PWM output of GPIO-11 |
| 0x2C | GPIO_12_PWM_CFG | 0x00 | RW | Configures PWM output of GPIO-12 |
| 0x2D | GPIO_13_PWM_CFG | 0x00 | RW | Configures PWM output of GPIO-13 |
| 0x2E | GPIO_14_PWM_CFG | 0x00 | RW | Configures PWM output of GPIO-14 |
| 0x2F | GPIO_15_PWM_CFG | 0x00 | RW | Configures PWM output of GPIO-15 |
| 0x30 | PWM_MASTER_EN | 0x00 | RW | PWM master enable |
| 0x40 | PWM_0_SET | 0x00 | RW | PWM0 setup |
| 0x41 | PWM_0_CTRL | 0x00 | RW | PWM0 control |
| 0x42 | PWM_0_RAMP_RATE | 0x00 | RW | PWM0 ramp rate |
| 0x43 | PWM_0_TRIG | 0x00 | RW | PWM0 trigger |
| 0x44 | PWM_1_SET | 0x00 | RW | PWM1 setup |
| 0x45 | PWM_1_CTRL | 0x00 | RW | PWM1 control |
| 0x46 | PWM_1_RAMP_RATE | 0x00 | RW | PWM1 ramp rate |
| 0x47 | PWM_1_TRIG | 0x00 | RW | PWM1 trigger |
| 0x48 | PWM_2_SET | 0x00 | RW | PWM2 setup |
| 0x49 | PWM_2_CTRL | 0x00 | RW | PWM2 control |
| 0x4A | PWM_2_RAMP_RATE | 0x00 | RW | PWM2 ramp rate |
| 0x4B | PWM_2_TRIG | 0x00 | RW | PWM2 trigger |
| 0x4C | PWM_3_SET | 0x00 | RW | PWM3 setup |
| 0x4D | PWM_3_CTRL | 0x00 | RW | PWM3 control |
| 0x4E | PWM_3_RAMP_RATE | 0x00 | RW | PWM3 ramp rate |
| 0x4F | PWM_3_TRIG | 0x00 | RW | PWM3 trigger |
| 0x50 | PWM_4_SET | 0x00 | RW | PWM4 setup |
| 0x51 | PWM_4_CTRL | 0x00 | RW | PWM4 control |
| 0x52 | PWM_4_RAMP_RATE | 0x00 | RW | PWM4 ramp rate |

Table 8. Register map (continued)

| Address | Register name | Reset value | I ² C | Register function |
|---------|---------------------|-------------|------------------|--|
| 0x53 | PWM_4_TRIG | 0x00 | RW | PWM4 trigger |
| 0x54 | PWM_5_SET | 0x00 | RW | PWM5 setup |
| 0x55 | PWM_5_CTRL | 0x00 | RW | PWM5 control |
| 0x56 | PWM_5_RAMP_RATE | 0x00 | RW | PWM5 ramp rate |
| 0x57 | PWM_5_TRIG | 0x00 | RW | PWM5 trigger |
| 0x58 | PWM_6_SET | 0x00 | RW | PWM6 setup |
| 0x59 | PWM_6_CTRL | 0x00 | RW | PWM6 control |
| 0x5A | PWM_6_RAMP_RATE | 0x00 | RW | PWM6 ramp rate |
| 0x5B | PWM_6_TRIG | 0x00 | RW | PWM6 trigger |
| 0x5C | PWM_7_SET | 0x00 | RW | PWM7 setup |
| 0x5D | PWM_7_CTRL | 0x00 | RW | PWM7 control |
| 0x5E | PWM_7_RAMP_RATE | 0x00 | RW | PWM7 ramp rate |
| 0x5F | PWM_7_TRIG | 0x00 | RW | PWM7 trigger |
| 0x70 | CAP_SEN_CTRL | 0x00 | RW | Capacitive sensor control |
| 0x71 | RATIO_ENG_REPT_CTRL | 0x00 | RW | Ratio engine report control (only available in final silicon) |
| 0x72 | CH_SEL | 0x00000000 | RW | Selects active capacitive channels |
| 0x76 | CAL_INT | 0x00 | RW | 10ms – 64S calibration interval |
| 0x77 | CAL_MOD | 0x00 | RW | Selects calibration model |
| 0x78 | MAF_SET | 0x00 | RW | Control of median averaging filter |
| 0x7C | DATA_TYPE | 0x00 | RW | Selects type of data available in channel data ports. 0x01: TVR 0x02: EVR 0x03: Channel delay 0x04: Impedance (13-bit) 0x05: Calibrated Impedance (13-bit) 0x06: Locked impedance (13-bit) |
| 0x80 | RATIO_ENG_SET | 0x00 | RW | General setup of ratio engine |
| 0x81 | RATIO_ENG_1_CFG | 0x00 | RW | Configuration of ratio engine 1 |
| 0x82 | RATIO_ENG_2_CFG | 0x00 | RW | Configuration of ratio engine 2 |
| 0x83 | RATIO_ENG_STA | 0x00 | R | Status of ratio engine |
| 0x84 | RATIO_ENG_1_DATA | 0x000000 | R | Output data of ratio engine 1 |
| 0x87 | RATIO_ENG_2_DATA | 0x000000 | R | Output data of ratio engine 2 |
| 0x90 | KEY_FILT_CTRL | 0x00 | | General key filter control |

Table 8. Register map (continued)

| Address | Register name | Reset value | I ² C | Register function |
|---------|------------------|-------------|------------------|--|
| 0x92 | KEY_FILT_GROUP-1 | 0x00000000 | | Define channels included in key filter group 1 |
| 0x96 | KEY_FILT_GROUP-2 | 0x00000000 | | Define channels included in key filter group 2 |
| 0x9A | KEY_FILT_DATA | 0x00000000 | | Filtered touchkey data |
| 0xB4 | TOUCH_DET | 0x00000000 | R | Touch detection register (real time) |
| 0xC0 | CH_DATA-0 | 0x0000 | | Channel data according to data type setting |
| 0xC2 | CH_DATA-1 | 0x0000 | | |
| 0xC4 | CH_DATA-2 | 0x0000 | | |
| 0xC6 | CH_DATA-3 | 0x0000 | | |
| 0xC8 | CH_DATA-4 | 0x0000 | | |
| 0xCA | CH_DATA-5 | 0x0000 | | |
| 0xCC | CH_DATA-6 | 0x0000 | | |
| 0xCE | CH_DATA-7 | 0x0000 | | |
| 0xD0 | CHDATA-8 | 0x0000 | | |
| 0xD2 | CH_DATA-9 | 0x0000 | | |
| 0xD4 | CH_DATA-10 | 0x0000 | | |
| 0xD6 | CH_DATA-11 | 0x0000 | | |
| 0xD8 | CH_DATA-12 | 0x0000 | | |
| 0xDA | CH_DATA-13 | 0x0000 | | |
| 0xDC | CH_DATA-14 | 0x0000 | | |
| 0xDE | CH_DATA-15 | 0x0000 | | |
| 0xE0 | CH_DATA-16 | 0x0000 | | |
| 0xE2 | CH_DATA-17 | 0x0000 | | |
| 0xE4 | CH_DATA-18 | 0x0000 | | |
| 0xE6 | CH_DATA-19 | 0x0000 | | |
| 0xE8 | CH_DATA-20 | 0x0000 | | |
| 0xEA | CH_DATA-21 | 0x0000 | | |
| 0xEC | CH_DATA-22 | 0x0000 | | |
| 0xEE | CH_DATA-23 | 0x0000 | | |

7 System controller

The system controller contains the registers that control the following functions:

- Device identification
- Version identification
- Power state management
- Clock speed management
- Clock gating to various modules

Table 9. System controller registers

| Address | Register name | Reset value | R/W | Description |
|---------|---------------|-------------|-----|---|
| 0x00 | CHIP_ID | 0x2431 | R | CHIP identification number. MSB: 0x24, LSB: 0x31 |
| 0x02 | ID_VER | 0x03 | R | Version of device |
| 0x03 | SYSCON-1 | 0x00 | RW | General system c control |
| 0x04 | SYSCON-2 | 0xFE | RW | Sensor and PWM clock divider |

SYSCON-1

General system control

Address: 0x03

Type: R/W

Reset: 0x00

Description: The general system control register (SYSCON-1) controls the operation state and clock speed of the device.

| | | | | | | | |
|----------|----------|----------|--------|----------|----------|----------|--------|
| 7 | 6 | 5 | 4 | 3 | 2 | 1 | 0 |
| RESERVED | RESERVED | RESERVED | CLKSPD | SLEEP_EN | Reserved | SOFT_RST | HIBRNT |
| RW | RW | RW | RW | RW | RW | RW | RW |
| 0 | 0 | 0 | 0 | 0 | 0 | 0 | 0 |

- [7:5] RESERVED: Do not write to these bits. Reads '0'. Writing '1' to these bits may result in unpredictable behaviour.
- [4] CLKSPD: Selects the macro engine's speed.
 - 0: 2 MHz
 - 1: RESERVED
- [3] SLEEP_EN: Enable or disable the sleep mode. Under all operating conditions, this bit should be set to '0'.
 - 1: Enable the touch sensor's sleep mode
 - 0: Disable the touch sensor's sleep mode
- [2] RESERVED: Do not write to these bits. Reads '0'.
- [1] SOFT_RST: Soft reset.
 - 1: To perform soft reset.
- [0] HIBRNT: Hibernate.
 - 1: To force the device to hibernate mode.

SYSCON-2**Sensor and PWM clock divider****Address:** 0x04**Type:** R/W**Reset:** 0xFE**Description:** Sensor and PWM clock divider. The SYSCON-2 register controls the sensor and PWM clock speed, and the clock gating of various functional modules.

This bit will always read '0'. as the I2C transaction to read this bit will wake up the device from hibernate mode.

| 7 | 6 | 5 | 4 | 3 | 2 | 1 | 0 |
|----------|---|---|----------|---|----------|---------|--------|
| SCLK_DIV | | | PCLK_DIV | | GPIO_CLK | PWM_CLK | CS_CLK |
| RW | | | RW | | RW | | RW |
| 1 | | | 1 | | 1 | | 0 |

[7:5] SCLK_DIV: Sensor clock divider.

000, 001, 010: RESERVED

011: 64

100: 128

101: 256

110: 512

111: 1024

Sensor clock is 2 MHz / (PRBS_Factor * SCLK_DIV[2:0])

PRBS factor = 4.5

[4:3] PCLK_DIV: PWM clock divider

00 for 16 kHz

01 for 32 kHz

10 for 64 kHz

11 for 128 kHz

[2] GPIO_CLK: GPIO clock disable

Write "1" to diWrite "1" to disable the clock to GPIO module.

When clock to GPIO module is disabled, access to GPIO module register will not work correctly.

[1] PMW_CLK: PWM clock disable

Write "1" to disable the clock to PWM module.

When clock to PWM module is disabled, access to PWM module register will not work correctly.

[0] CS_CLK: Capacitive sensor clock disable

Write "1" to disable the clock to capacitive sensor module

When clock to touch module is disabled, access to touch module registers will not work correctly.

7.1 Interrupt system

This module controls the interruption to the host based on the activity of other modules in the system, such as the capacitive sensing, GPIO and PWM modules.

Figure 9. Interrupt system

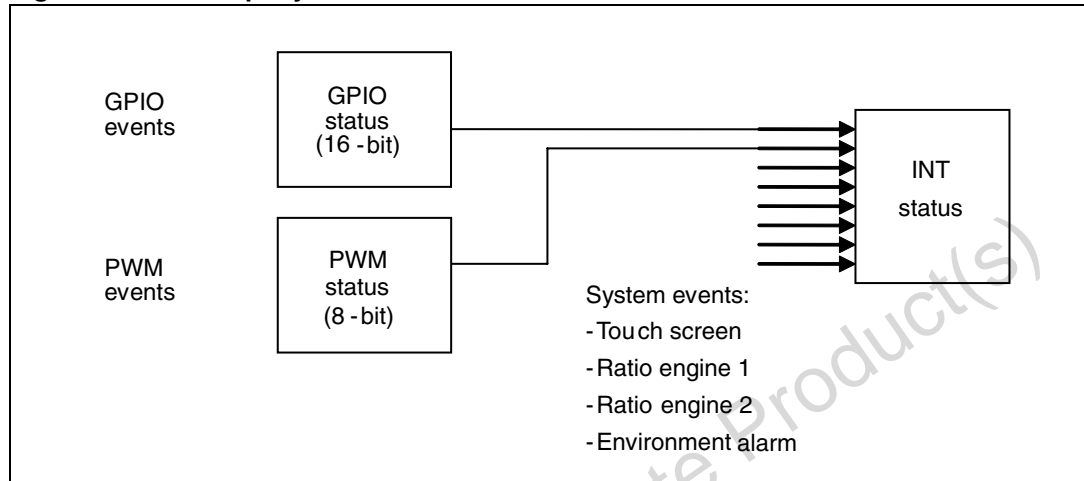

Table 10. Interrupt system registers

| Address | Register name | Reset value | R/W | Description |
|---------|---------------|-------------|-----|--------------------------------|
| 0x06 | INT_CTRL | 0x00 | RW | Interrupt control register |
| 0x08 | INT_STA | 0x00 | RW | Interrupt status register |
| 0x09 | INT_EN | 0x00 | RW | Interrupt enable register |
| 0x0A | GPIO_INT_STA | 0x0000 | RW | Interrupt status GPIO register |
| 0x0C | GPIO_INT_EN | 0x0000 | RW | Interrupt enable GPIO register |
| 0x0E | PWM_INT_STA | 0x00 | RW | Interrupt status PWM register |
| 0x0F | PWM_INT_EN | 0x00 | RW | Interrupt enable PWM register |

INT_CTRL**Interrupt control register****Address:** 0x06**Type:** R/W**Reset:** 0x00**Description:** INT_CTRL controls the interrupt signal generation.

| 7 | 6 | 5 | 4 | 3 | 2 | 1 | 0 |
|----------|----|----|----|----|---------|----------|--------|
| RESERVED | | | | | INT_POL | INT_TYPE | INT_EN |
| RW | RW | RW | RW | RW | RW | RW | RW |
| 0 | 0 | 0 | 0 | 0 | 0 | 0 | 0 |

[7:3] RESERVED

[2] INT_POL: Interrupt polarity

0: Active low

1: Active high

[1] INT_TYPE: Interrupt trigger type

0: Level trigger

1: Edge trigger

[0] INT_EN: Interrupt enable

1: Enable the interrupt

0: Disable the interrupt

INT_STA

Interrupt status register

Address: 0x08

Type: R/W

Reset: 0x00

Description: This register holds interrupt status from each event.

| 7 | 6 | 5 | 4 | 3 | 2 | 1 | 0 |
|------|-----|--------|-----|-----|-------|-----|-----|
| GPIO | PWM | WAKEUP | ENV | EOC | TOUCH | RE2 | RE1 |
| RW | RW | RW | RW | RW | RW | RW | RW |
| 0 | 0 | 0 | 0 | 0 | 0 | 0 | 0 |

- [7] GPIO: Activity in GPIO
Read '1' if GPIO event occurs
Write '1' to clear the interrupt status
- [6] PWM: Any channel of PWM has completed the programmed sequence
Read '1' if PWM event occurs
Write '1' to clear the interrupt status
- [5] Device wake up from SLEEP or HIBERNATE mode
Read '1' if wake-up event occurs
Write '1' to clear the interrupt status
- [4] ENV: Possible drastic/abnormal environmental changes that requires attention from system software. This event includes 'calibration stuck' and 'tuning out of range'. If this bit is set, it is recommended that the host software initiates an unconditional calibration.
Read '1' if the events occur
Write '1' to clear the interrupt status
- [3] EOC: End of calibration
Read '1' if the host-triggered calibration has completed
Write '1' to clear the interrupt status
- [2] TOUCH: Touch-key event
Read '1' if touch is detected
Write '1' to clear the interrupt status
- [1] RE2: Ratio engine 2 event
Read '1' if ratio engine 2 detects a touch or data is ready
Write '1' to clear the interrupt status
- [0] RE1: Ratio engine 1 event
Read '1' if ratio engine 1 detects a touch or data is ready
Write '1' to clear the interrupt status

INT_EN**Interrupt enable register****Address:** 0x09**Type:** R/W**Reset:** 0x00**Description:** Controls interrupt source enable.

| 7 | 6 | 5 | 4 | 3 | 2 | 1 | 0 |
|------|-----|--------|-----|-----|-------|-----|-----|
| GPIO | PWM | WAKEUP | ENV | EOC | TOUCH | RE2 | RE1 |
| RW | RW | RW | RW | RW | RW | RW | RW |
| 0 | 0 | 0 | 0 | 0 | 0 | 0 | 0 |

- [7] GPIO: Activity in GPIO
Write '1' to enable interrupt signal from GPIO
Write '0' to disable interrupt signal from GPIO
- [6] PWM: Any channel of PWM has completed the programmed sequence
Write '1' to enable interrupt signal from PWM
Write '0' to disable interrupt signal from PWM
- [5] Device wake up from SLEEP or HIBERNATE mode
Write '1' to enable interrupt signal from wake-up event
Write '0' to disable interrupt signal from wake-up event
- [4] ENV: Possible drastic/abnormal environmental changes that requires attention from system software. This event includes 'calibration stuck' and 'tuning out of range'
Write '1' to enable interrupt signal from calibration/tuning event
Write '0' to disable interrupt signal from calibration/tuning event
- [3] EOC: End of calibration
Write '1' to enable interrupt signal from end of calibration event
Write '0' to disable interrupt signal from end of calibration event
- [2] TOUCH: Touchkey event
System should access touch detection register when this interrupt is received.
Touch interrupt source needs to be enabled to activate key filter data.
Write '1' to enable interrupt signal from touch event
Write '0' to disable interrupt signal from touch event
- [1] RE2: Ratio engine 2 event
This bit needs to be enabled before accessing ratio engine data buffer
Write '1' to enable interrupt signal from ratio engine 2
Write '0' to disable interrupt signal from ratio engine 2
- [0] RE1: Ratio engine 1 event
This bit needs to be enabled before accessing ratio engine data buffer
Write '1' to enable interrupt signal from ratio engine 1
Write '0' to disable interrupt signal from ratio engine 1

GPIO_INT_STA

Interrupt status GPIO register

Address: 0x0A – 0x0B

Type: R/W

Reset: 0x0000

Description: This register reflects the status of GPIO that has been configured as input. When there is a change in GPIO state, the corresponding bit will be set to '1' by hardware. Writing '1' to the corresponding bit clears it. Writing '0' has no effect.

LSB (0x0A)

| | | | | | | | |
|------|------|------|------|------|------|------|------|
| 7 | 6 | 5 | 4 | 3 | 2 | 1 | 0 |
| IO-7 | IO-6 | IO-5 | IO-4 | IO-3 | IO-2 | IO-1 | IO-0 |
| RW | RW | RW | RW | RW | RW | RW | RW |
| 0 | 0 | 0 | 0 | 0 | 0 | 0 | 0 |

MSB (0x0B)

| | | | | | | | |
|-------|-------|-------|-------|-------|-------|------|------|
| 7 | 6 | 5 | 4 | 3 | 2 | 1 | 0 |
| IO-15 | IO-14 | IO-13 | IO-12 | IO-11 | IO-10 | IO-9 | IO-8 |
| RW | RW | RW | RW | RW | RW | RW | RW |
| 0 | 0 | 0 | 0 | 0 | 0 | 0 | 0 |

[7:0] IO - X: Interrupt status of GPIO - X

Read '1' if state transition is detected in corresponding GPIO channel

Write '1' to clear the interrupt status.

GPIO_INT_EN**Interrupt enable GPIO register****Address:** 0x0C – 0x0D**Type:** R/W**Reset:** 0x0000**Description:** This register is used to enable the generation of interrupt signal, at the INT pin.**LSB (0x0C)**

| | | | | | | | |
|------|------|------|------|------|------|------|------|
| 7 | 6 | 5 | 4 | 3 | 2 | 1 | 0 |
| IO-7 | IO-6 | IO-5 | IO-4 | IO-3 | IO-2 | IO-1 | IO-0 |
| RW | RW | RW | RW | RW | RW | RW | RW |
| 0 | 0 | 0 | 0 | 0 | 0 | 0 | 0 |

MSB (0x0D)

| | | | | | | | |
|-------|-------|-------|-------|-------|-------|------|------|
| 7 | 6 | 5 | 4 | 3 | 2 | 1 | 0 |
| IO-15 | IO-14 | IO-13 | IO-12 | IO-11 | IO-10 | IO-9 | IO-8 |
| RW | RW | RW | RW | RW | RW | RW | RW |
| 0 | 0 | 0 | 0 | 0 | 0 | 0 | 0 |

[7:0] IO - X

Interrupt status of GPIO - X

Read '1' if state transition is detected in corresponding GPIO channel

Write '1' to clear the interrupt status.

PWM_INT_STA**Interrupt status PWM register****Address:** 0x0E**Type:** R/W**Reset:** 0x00**Description:** When a PWM controller completes the PWM sequence, the corresponding bit in this register goes to '1'. Write '1' in this register clears the written bit, writing '0' has no effect.

| | | | | | | | |
|-------|-------|-------|-------|-------|-------|-------|-------|
| 7 | 6 | 5 | 4 | 3 | 2 | 1 | 0 |
| PWM-7 | PWM-6 | PWM-5 | PWM-4 | PWM-3 | PWM-2 | PWM-1 | PWM-0 |
| RW | RW | RW | RW | RW | RW | RW | RW |
| 0 | 0 | 0 | 0 | 0 | 0 | 0 | 0 |

[7:0] PWM - X

Interrupt status of PWM – X.

Read '1' if the corresponding PWM channel complete programmed sequence

Write '1' to clear the interrupt status

PWM_INT_EN

Interrupt enable PWM enable register

Address: 0x0F

Type: R/W

Reset: 0x00

Description: Writing '1' to this register enables the generation of INT by the corresponding PWM channel.

| | | | | | | | |
|-------|-------|-------|-------|-------|-------|-------|-------|
| 7 | 6 | 5 | 4 | 3 | 2 | 1 | 0 |
| PWM-7 | PWM-6 | PWM-5 | PWM-4 | PWM-3 | PWM-2 | PWM-1 | PWM-0 |
| RW | RW | RW | RW | RW | RW | RW | RW |
| 0 | 0 | 0 | 0 | 0 | 0 | 0 | 0 |

[7:0] PWM - X

Enable of PWM – X.

Write '1' to the corresponding bit to enable interrupt generated by a PWM channel

Obsolete Product(s) - Obsolete Product(s)

8 Interrupt service routine

On receiving an interrupt, system software should:

Read InterruptStatus

```
If (GPIO.bit==1)
```

```
{
```

```
Read InterruptStatusGPIO
```

```
    Process GPIO INT
```

```
    Write InterruptStatusGPIO to clear the corresponding bit
```

```
Write InterruptStatus to clear the corresponding bit
```

```
}
```

```
If (PWM.bit==1)
```

```
{
```

```
Read InterruptStatusPWM
```

```
    Process PWM INT
```

```
    Write InterruptStatusPWM to clear the corresponding bit
```

```
Write InterruptStatus to clear the corresponding bit
```

```
}
```

```
If ( EV_ALARM or TOUCHSCREEN or TOUCHKEY or RE1/2)
```

```
{
```

```
    Process INT
```

```
    Write InterruptStatus to clear the corresponding bit
```

```
}
```

9 GPIO controller

A total of 16 GPIOs are available in the STMPE24M31/STMPE16M31. Most of the GPIOs are sharing physical pins with some alternate functions. The GPIO controller contains the registers that allow the host system to configure each of the pins into either a GPIO, or one of the alternate functions. Unused GPIOs should be configured as outputs to minimize the power consumption.

Table 11. GPIO controller registers

| Address | Register name | Reset value | R/W | Description |
|---------|---------------|-------------|-----|----------------------------------|
| 0x10 | GPDR | 0X0000 | R/W | GPIO direction register |
| 0x12 | GPMR | 0X0000 | R/W | GPOIO monitor pin state register |
| 0x14 | GPSR | 0X0000 | R/W | GPIO set pin register |
| 0x16 | GPFR | 0X0000 | R/W | GPIO alternate function register |

GPIO_DIR

GPIO direction register

Address: 0x10 – 0x11

Type: RW

Reset: 0x00

Description: Direction setting of the GPIO.

LSB (0x10)

| 7 | 6 | 5 | 4 | 3 | 2 | 1 | 0 |
|------|------|------|------|------|------|------|------|
| IO-7 | IO-6 | IO-5 | IO-4 | IO-3 | IO-2 | IO-1 | IO-0 |
| RW | RW | RW | RW | RW | RW | RW | RW |
| 0 | 0 | 0 | 0 | 0 | 0 | 0 | 0 |

MSB (0x11)

| 7 | 6 | 5 | 4 | 3 | 2 | 1 | 0 |
|-------|-------|-------|-------|-------|-------|------|------|
| IO-15 | IO-14 | IO-13 | IO-12 | IO-11 | IO-10 | IO-9 | IO-8 |
| RW | RW | RW | RW | RW | RW | RW | RW |
| 0 | 0 | 0 | 0 | 0 | 0 | 0 | 0 |

[7:0] IO - X

Write '1' to a bit to set the corresponding I/O to output.

Write '0' to a bit to set the corresponding I/O to input.

GPIO_MP_STA**GPIO monitor pin state register****Address:** 0x12 – 0x13**Type:** R**Reset:** 0x00**Description:** Contains the state of all GPIO.**LSB (0x12)**

| | | | | | | | |
|------|------|------|------|------|------|------|------|
| 7 | 6 | 5 | 4 | 3 | 2 | 1 | 0 |
| IO-7 | IO-6 | IO-5 | IO-4 | IO-3 | IO-2 | IO-1 | IO-0 |
| RW | RW | RW | RW | RW | RW | RW | RW |
| 0 | 0 | 0 | 0 | 0 | 0 | 0 | 0 |

MSB (0x13)

| | | | | | | | |
|-------|-------|-------|-------|-------|-------|------|------|
| 7 | 6 | 5 | 4 | 3 | 2 | 1 | 0 |
| IO-15 | IO-14 | IO-13 | IO-12 | IO-11 | IO-10 | IO-9 | IO-8 |
| RW | RW | RW | RW | RW | RW | RW | RW |
| 0 | 0 | 0 | 0 | 0 | 0 | 0 | 0 |

[7:0] IO - X

Read '1' if the corresponding IO is in HIGH state

Read '0' if the corresponding IO is in LOW state

GPIO_SET_PIN

GPIO set pin state register

Address: 0x14 – 0x15
Type: RW
Reset: 0x00
Description: Setting of the I/O output state.

LSB (0x14)

| | | | | | | | |
|------|------|------|------|------|------|------|------|
| 7 | 6 | 5 | 4 | 3 | 2 | 1 | 0 |
| IO-7 | IO-6 | IO-5 | IO-4 | IO-3 | IO-2 | IO-1 | IO-0 |
| RW | RW | RW | RW | RW | RW | RW | RW |
| 0 | 0 | 0 | 0 | 0 | 0 | 0 | 0 |

MSB (0x15)

| | | | | | | | |
|-------|-------|-------|-------|-------|-------|------|------|
| 7 | 6 | 5 | 4 | 3 | 2 | 1 | 0 |
| IO-15 | IO-14 | IO-13 | IO-12 | IO-11 | IO-10 | IO-9 | IO-8 |
| RW | RW | RW | RW | RW | RW | RW | RW |
| 0 | 0 | 0 | 0 | 0 | 0 | 0 | 0 |

[7:0] IO - X
 Write '1' to set the corresponding IO output state to HIGH
 Write '0' to set the corresponding IO output state to LOW

GPIO_AF**GPIO function register****Address:** 0x16 – 0x17**Type:** RW**Reset:** 0x00**Description:** Setting of the GPIO function.**LSB (0x16)**

| 7 | 6 | 5 | 4 | 3 | 2 | 1 | 0 |
|------|------|------|------|------|------|------|------|
| IO-7 | IO-6 | IO-5 | IO-4 | IO-3 | IO-2 | IO-1 | IO-0 |
| RW | RW | RW | RW | RW | RW | RW | RW |
| 0 | 0 | 0 | 0 | 0 | 0 | 0 | 0 |

MSB (0x17)

| 7 | 6 | 5 | 4 | 3 | 2 | 1 | 0 |
|-------|-------|-------|-------|-------|-------|------|------|
| IO-15 | IO-14 | IO-13 | IO-12 | IO-11 | IO-10 | IO-9 | IO-8 |
| RW | RW | RW | RW | RW | RW | RW | RW |
| 0 | 0 | 0 | 0 | 0 | 0 | 0 | 0 |

[7:0] IO - X

Write '1' to set the corresponding GPIO to alternate function (IO)

Write '0' to set the corresponding GPIO to primary function (capacitive sensor)

10 PWM array controller

The STMPE24M31 integrates 8 independent PWM controllers capable of blinking and brightness control.

Each of the PWM controllers can be programmed to execute a series of blinking/brightness control actions. One PWM controller could be mapped to more than one GPIO, allowing multiple GPIO outputs to share a PWM controller.

Each PWM controller can be connected to any of GPIO channel through the routing network which is controlled by GPIO_n_PWM_CFG register (n = GPIO channel number).

Figure 10. PWM array controller

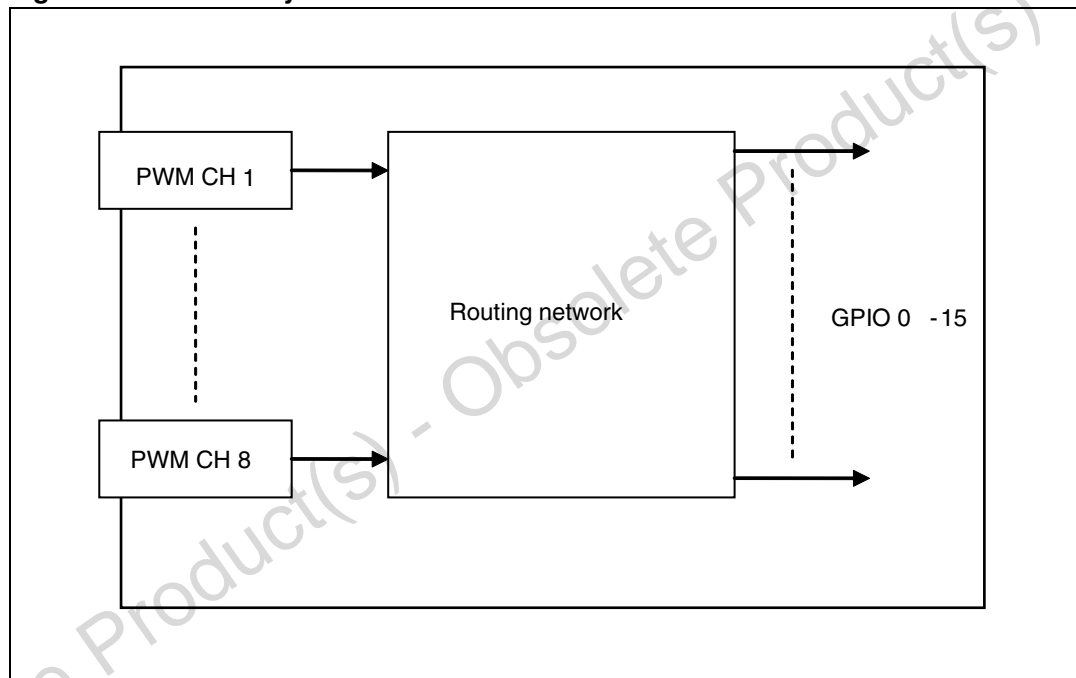

GPIO_n_PWM_CFG

PWM array controller

Address: 0x20-2F

Type: RW

Reset: 0x00

Description: This register controls the routing network which connects each PWM channel to any GPIO channel. GPIO_n_PWM_CFG register (n=0-15, represent the GPIO channel number)

| | | | | | | | |
|--------|----------|----|----|----------|---------|----|----|
| 7 | 6 | 5 | 4 | 3 | 2 | 1 | 0 |
| OUT_EN | RESERVED | | | OUT_IDLE | PWM_SEL | | |
| RW | RW | RW | RW | RW | RW | RW | RW |
| 0 | 0 | 0 | 0 | 0 | 0 | 0 | 0 |

- [7] OUT_EN:
Write '1' to set the I/O (configured as GPIO) to operate as PWM Output. All GPIO register setting will be by-passed. To get PWM output on this pin, the GPDR register should be set to output.
- [6:4] RESERVED
- [3] OUT_IDLE:
Write '1' to set the I/O state to HIGH after PWM sequence has been completed
Write '0' to set the I/O state to LOW after PWM sequence has been completed
- [2:0] PWM_SEL:
PWM controller selection

11 PWM controller

The PWM controller allows to control the brightness, ramping/fading and blinking of LEDs. The STMPE24M31/16M31 features 8 independent PWM controllers.

The PWM controllers outputs are connected to the GPIO through the PWM array controller. The PAC provides the following list of flexibility to the overall PWM's system:

- Each GPIO may utilize the output of 1 of the 8 PWM controllers.
- Up to 16 GPIO may be controlled by the same PWM at the same time.
- Each of the PWM could be programmed to be triggered by a touch sensing input.

The PWM controller uses a base clock of 512 kHz, clock pulses have a variable duty cycle of 0 to 100% in 16 steps. The PWM's frequency is 32 kHz (to be out of audio range).

11.1 PWM function register map

This section lists and describes the PWM function registers of the STMPE16M31 and STMPE24M31 devices, starting with a register map and then provides detailed descriptions of register types.

Table 12. PWM function registers

| Address | Register name | Reset value | R/W | Description |
|---------|---------------|-------------|-----|-------------------|
| 0x30 | PWM_MASTER_EN | 0x00 | RW | PWM master enable |
| 0x40 | PWM_0_SET | 0x00 | RW | PWM0 setup |
| 0x41 | PWM_0_CTRL | 0x00 | RW | PWM0 control |
| 0x42 | PWM_0_RAMP | 0x00 | RW | PWM0 ramp rate |
| 0x43 | PWM_0_TRIG | 0x00 | RW | PWM0 trigger |
| 0x44 | PWM_1_SET | 0x00 | RW | PWM1 setup |
| 0x45 | PWM_1_CTRL | 0x00 | RW | PWM1 control |
| 0x46 | PWM_1_RAMP | 0x00 | RW | PWM1 ramp rate |
| 0x47 | PWM_1_TRIG | 0x00 | RW | PWM1 trigger |
| 0x48 | PWM_2_SET | 0x00 | RW | PWM2 setup |
| 0x49 | PWM_2_CTRL | 0x00 | RW | PWM2 control |
| 0x4A | PWM_2_RAMP | 0x00 | RW | PWM2 ramp rate |
| 0x4B | PWM_2_TRIG | 0x00 | RW | PWM2 trigger |
| 0x4C | PWM_3_SET | 0x00 | RW | PWM3 setup |
| 0x4D | PWM_3_CTRL | 0x00 | RW | PWM3 control |
| 0x4E | PWM_3_RAMP | 0x00 | RW | PWM3 ramp rate |
| 0x4F | PWM_3_TRIG | 0x00 | RW | PWM3 trigger |

Table 12. PWM function registers (continued)

| Address | Register name | Reset value | R/W | Description |
|---------|---------------|-------------|-----|----------------|
| 0x50 | PWM_4_SET | 0x00 | RW | PWM4 setup |
| 0x51 | PWM_4_CTRL | 0x00 | RW | PWM4 control |
| 0x52 | PWM_4_RAMP | 0x00 | RW | PWM4 ramp rate |
| 0x53 | PWM_4_TRIG | 0x00 | RW | PWM4 trigger |
| 0x54 | PWM_5_SET | 0x00 | RW | PWM5 setup |
| 0x55 | PWM_5_CTRL | 0x00 | RW | PWM5 control |
| 0x56 | PWM_5_RAMP | 0x00 | RW | PWM5 ramp rate |
| 0x57 | PWM_5_TRIG | 0x00 | RW | PWM5 trigger |
| 0x58 | PWM_6_SET | 0x00 | RW | PWM6 setup |
| 0x59 | PWM_6_CTRL | 0x00 | RW | PWM6 control |
| 0x5A | PWM_6_RAMP | 0x00 | RW | PWM6 ramp rate |
| 0x5B | PWM_6_TRIG | 0x00 | RW | PWM6 trigger |
| 0x5C | PWM_7_SET | 0x00 | RW | PWM7 setup |
| 0x5D | PWM_7_CTRL | 0x00 | RW | PWM7 control |
| 0x5E | PWM_7_RAMP | 0x00 | RW | PWM7 ramp rate |
| 0x5F | PWM_7_TRIG | 0x00 | RW | PWM7 trigger |

PWM_MASTER_EN

Master enable register

Address: 0x30

Type: RW

Reset: 0x00

Description: ENABLE/DISABLE setting of all PWM channels.

| 7 | 6 | 5 | 4 | 3 | 2 | 1 | 0 |
|-----|-----|-----|-----|-----|-----|-----|-----|
| EN7 | EN6 | EN5 | EN4 | EN3 | EN2 | EN1 | EN0 |
| RW | RW | RW | RW | RW | RW | RW | RW |
| 0 | 0 | 0 | 0 | 0 | 0 | 0 | 0 |

[7:0] EN-X (X = 7-0)

Write '1' to enable the corresponding PWM channel

Read '0' if the PWM sequence is completed

If PWM is set to be touch sensor-triggered :

Read '1' if the corresponding PWM channel is running

PWM_n_SET

PWM-n setup register

Address: 0x40, 0x44, 0x48, 0x4C, 0x50, 0x54, 0x58, 0x5C

Type: RW

Reset: 0x00

Description: Setting of brightness, time unit and ramp-mode.

| | | | | | | | |
|------------|----|----|----|--------|----|----|----------|
| 7 | 6 | 5 | 4 | 3 | 2 | 1 | 0 |
| BRIGHTNESS | | | | TIMING | | | RAMPMODE |
| RW | RW | RW | RW | RW | RW | RW | RW |
| 0 | 0 | 0 | 0 | 0 | 0 | 0 | 0 |

[7:4] BRIGHTNESS:

It defines the duty cycle during the ON period of the PWM channel output in no-ramp mode or the highest duty cycle to be reached in ramp-mode. The PWM duty cycle determines the brightness level of the LED that the PWM output drives.

'0000' : Duty cycle ratio 1:15 (6.25%, minimum brightness)

'0001': Duty cycle ratio 2:14 (12.50%)

'0010': Duty cycle ratio 3:13 (18.75%)

'0011': Duty cycle ratio 4:12 (25.00%)

'0100': Duty cycle ratio 5:11 (31.25%)

'0101': Duty cycle ratio 6:10 (37.50%)

'0110': Duty cycle ratio 7: 9 (43.75%)

'0111': Duty cycle ratio 8: 8 (50.00%)

'1000': Duty cycle ratio 9: 7 (56.25%)

'1001': Duty cycle ratio 10: 6 (62.50%)

'1010': Duty cycle ratio 11: 5 (68.75%)

'1011': Duty cycle ratio 12: 4 (75.00%)

'1100': Duty cycle ratio 13: 3 (81.25%)

'1101': Duty cycle ratio 14: 2 (87.50%)

'1110': Duty cycle ratio 15: 1 (93.75%)

'1111': Duty cycle ratio 16: 0 (100.00%, maximum brightness).

[3:1] TIMING:

It is the time unit from which the duration of the ON period and OFF period is defined in PWM-N control register.

'000' = 20 ms

'001' = 40 ms

'010' = 80 ms

'011' = 160 ms

'100' = 320 ms

'101' = 640 ms

'110' = 1280 ms

'111' = 2560 ms

[0] RAMP MODE:

Write '1' to enable ramp-mode

Write '0' to disable ramp-mode which in this setting the output goes to the set brightness level

PWM_n_CTRL

PWM-n control register

Address: 0x41, 0x45, 0x49, 0x4D, 0x51, 0x55, 0x59, 0x5D

Type: RW

Reset: 0x00

Description: Setting of ON/OFF period, repetition, and ON/OFF order.

| | | | | | | | |
|----------|----|----------|----|------------|----|----|-------|
| 7 | 6 | 5 | 4 | 3 | 2 | 1 | 0 |
| Period 0 | | Period 1 | | Repetition | | | Order |
| RW | RW | RW | RW | RW | RW | RW | RW |
| 0 | 0 | 0 | 0 | 0 | 0 | 0 | 0 |

[7:6] Period 0

Define the ON time based on time unit set in PWM-N setup register

'00': 1 time unit

'01': 2 time unit

'10': 3 time unit

'11': 4 time unit

[5:4] Period 1

Define the OFF time based on time unit set in PWM-N setup register

'00': No Off period

'01': 1 time unit

'10': 2 time unit

'11': 3 time unit

[3:1] Repetition

Set the repetition of programmed sequence (pair of period 0 and period 1)

'000': Infinite repetition

'001': Execute only one pair

'010': Execute 2 pairs

'011': Execute 3 pairs

'100': Execute 4 pairs

'101': Execute 5 pairs

'110': Execute 6 pairs

'111': Execute 7 pairs

[0] Order

Set the order of period 0 and period 1

'1': sequence = period 1 and then period 0

'0': sequence = period 0 and then period 1

PWM_n_RAMP_RATE

PWM-N ramp rate register

Address: 0x42, 0x46, 0x4A, 0x4E, 0x52, 0x56, 0x5A, 0x5E

Type: RW

Reset: 0x00

Description: Setting of ramp rate

| | | | | | | | |
|-----|----------|----------|----|----|--------|----|----|
| 7 | 6 | 5 | 4 | 3 | 2 | 1 | 0 |
| INV | Reserved | RampDown | | | RampUp | | |
| RW | RW | RW | RW | RW | RW | RW | RW |
| 0 | 0 | 0 | 0 | 0 | 0 | 0 | 0 |

[7] INV
 LED driving/sinking mode
 Write '1' for LED sinking mode (HIGH = LED Off, LOW = LED On)
 Write '0' for LED driving mode (HIGH = LED On, LOW = LED Off)

[6] Reserved

[5:3] RampDown
 Set the PWM ramp down rate
 '000' : 1/4 of time unit per brightness level change
 '001' : 1/8 of time unit per brightness level change
 '010' : 1/16 of time unit per brightness level change
 '011' : 1/32 of time unit per brightness level change
 '100' : 1/64 of time unit per brightness level change
 '101' : 1/128 of time unit per brightness level change
 '110' : reserved
 '111' : reserved

[2:0] RampUp
 Set the PWM ramp up rate
 '000' : 1/4 of time unit per brightness level change
 '001' : 1/8 of time unit per brightness level change
 '010' : 1/16 of time unit per brightness level change
 '011' : 1/32 of time unit per brightness level change
 '100' : 1/64 of time unit per brightness level change
 '101' : 1/128 of time unit per brightness level change
 '110' : reserved
 '111' : reserved

PWM_n_TRIG

PWM-N trigger register

Address: 0x43, 0x47, 0x4B, 0x4F, 0x53, 0x57, 0x5B, 0x5F

Type: RW

Reset: 0x00

Description: Setting of touch sensor-triggered PWM.

| | | | | | | | |
|----------|----|----|-------|----|----|----|----|
| 7 | 6 | 5 | 4 | 3 | 2 | 1 | 0 |
| RESERVED | EN | | TS_CH | | | | |
| RW | RW | RW | RW | RW | RW | RW | RW |
| 0 | 0 | 0 | 0 | 0 | 0 | 0 | 0 |

[7:6] RESERVED

[6:5] EN:

Write '1' to enable touch sensor-triggered PWM function

Write '0' to disable touch sensor-triggered PWM function

[4:0] TS_CH

Define the touch sensor channel which is set as trigger of the corresponding PWM channel.

Obsolete Product(s) - Obsolete Product(s)

12 Basic PWM programming

The PWM controllers are capable of generating the following brightness patterns:

Figure 11. Pulses with programmable brightness, ON/OFF period and repetition

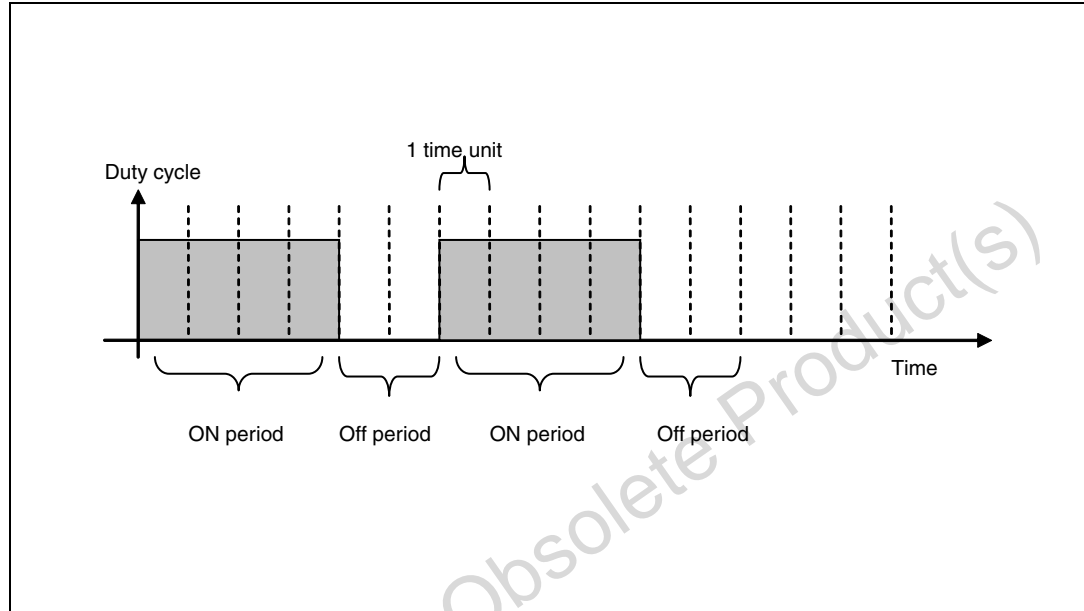

The registers need to be programmed for this sequence:

- On period = $\text{Period } 0[1:0] * \text{Time Unit } [3:0]$
- Off period = $\text{Period } 1[1:0] * \text{Time Unit } [3:0]$
- Duty cycle during on period = $\text{Brightness } [7:4]$
- Number of cycles = $\text{Repetition } [3:0]$
- Ramp-mode is disabled

Figure 12. Ramps with programmable brightness, ON/OFF period and repetition

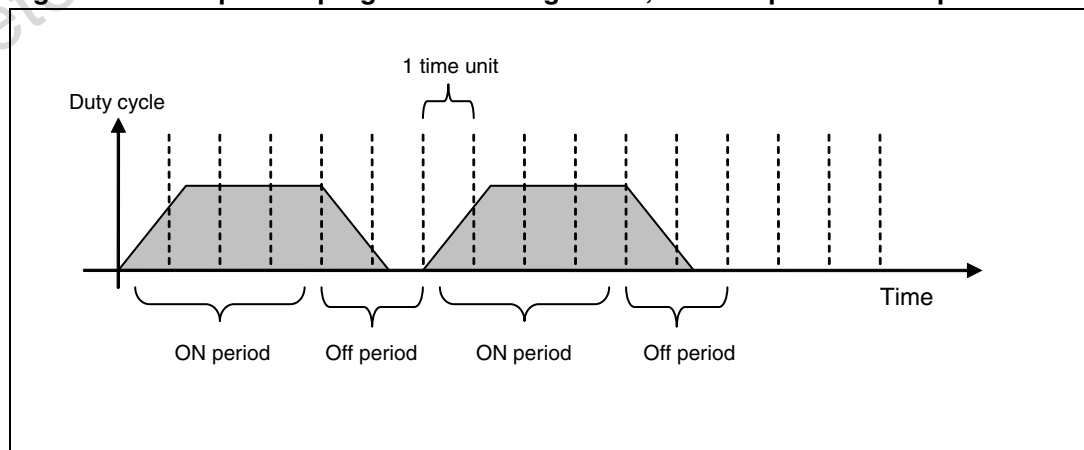

The registers need to be programmed for this sequence :

- On Period = Period 0[1:0] * Time Unit [3:0]
- Off Period = Period 1[1:0] * Time Unit [3:0]
- Duty cycle during On Period = Brightness [7:4]
- Number of cycles = Repetition [3:0]
- Ramp-Mode is enabled
- Ramp Up/Down Rate is programmable

Figure 13. Fixed brightness output

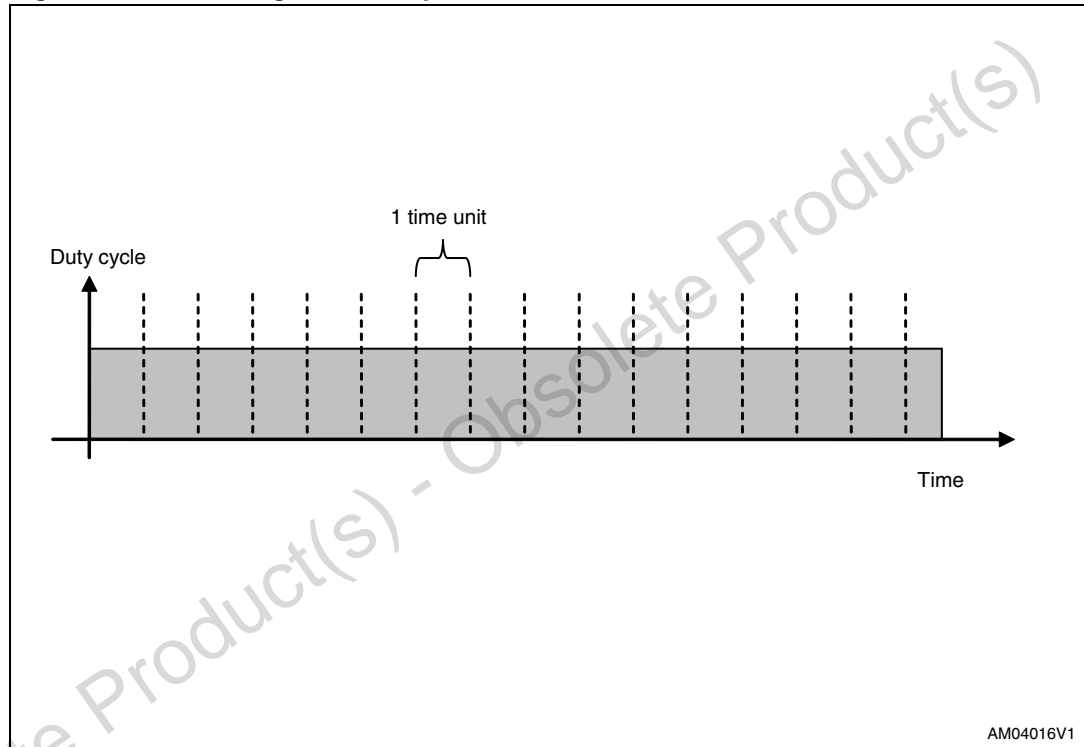

- On Period = Period 0[1:0] * Time Unit [3:0]
- Off Period = Don't Care
- Duty Cycle during On Period = Brightness [7:4]
- Number of cycles = Repetition [3:0] = 0 (infinite repetition)

12.1 Interrupt on basic PWM controller

A basic PWM controller could be programmed to generate interrupt on completion of blinking sequence. User needs to consider:

- a) Each basic PWM controller has its own bit in interrupt enable/status registers.

If enabled, the completion in any of the PWM controllers triggers an interrupt. No interrupt will be generated if infinite repetition is set.

Obsolete Product(s) - Obsolete Product(s)

13 Touch sensor controller

The STMPE16M31 and STMPE24M31 devices use the STMicroelectronics' patent pending capacitive front end. The capacitive sensor is configured by the following registers:

Table 13. Touch sensor controller registers

| Address | Register Name | Reset Value | R/W | Description |
|-----------|---------------------|-------------|-----|--|
| 0x70 | CH_SEN_CTRL | 0x00 | RW | Capacitive sensor control |
| 0x71 | RATIO_ENG_REPT_CTRL | 0x00 | RW | Ratio engine report control (only available in final silicon) |
| 0x72 | CH_SEL | 0x00000000 | RW | Selects active capacitive channels |
| 0x76 | CAL_INT | 0x00 | RW | 10ms – 64S calibration interval |
| 0x77 | CAL_MOD | 0x00 | RW | Selects calibration model |
| 0x78 | MAF_SET | 0x00 | RW | Median averaging filter (MAF) setting |
| 0x7C | DATA_TYPE | 0x00 | RW | Selects type of data available in channel data ports. 0x01: TVR 0x02: EVR 0x03: Channel delay 0x04: Impedance (13-bit) 0x05: Calibrated impedance (13-bit) 0x06: Locked impedance (13-bit) |
| 0xC0-0xEF | CH_DATA-n | 0x0000 | R/W | Channel data based on channel data type |

Figure 14. Touch sensing module flowchart

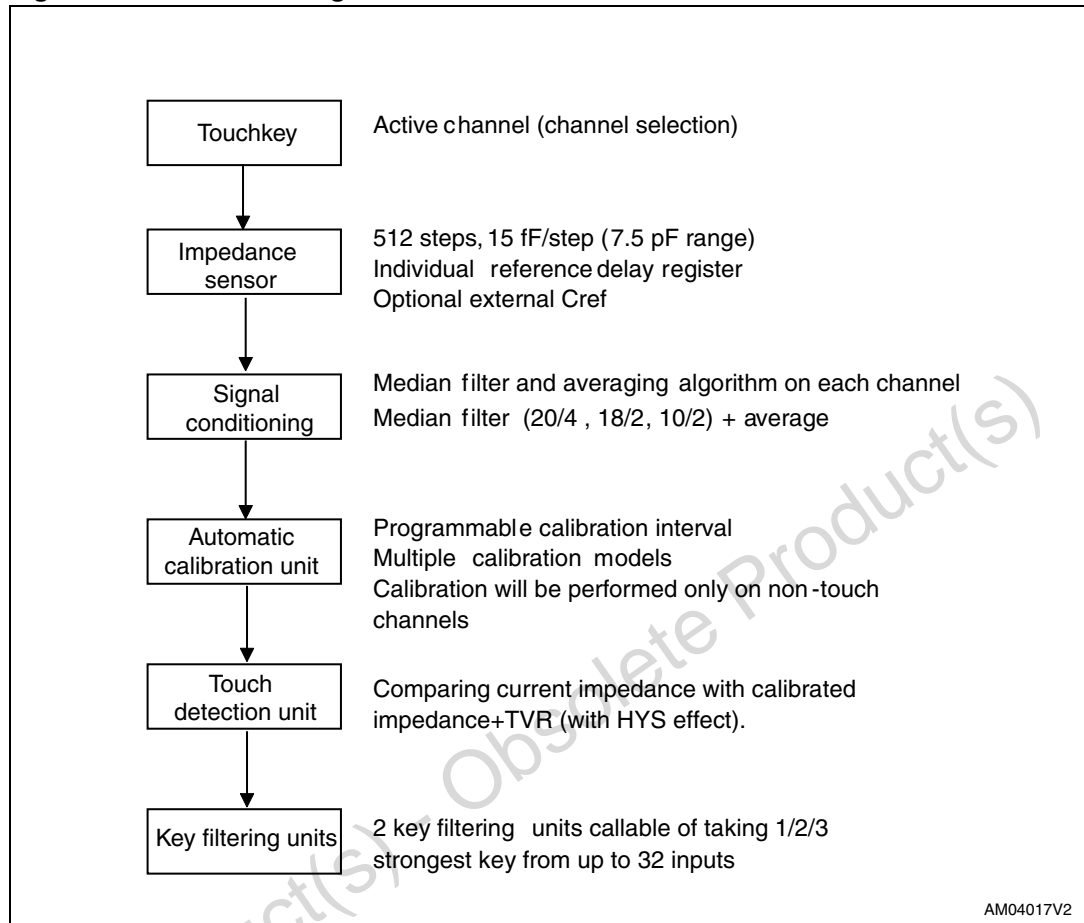

13.1 Sampling rate calculation

The capacitive sensor operates with a 2 MHz base clock, a single capacitive sensor scans up to 24 active channels.

The SCLK_DIV divides the sensor clock by 64-1024, giving 2 kHz-32 kHz sensor clock.

For capacitive sensing, a PRBS sequence is utilized to remove the effect of surrounding noise. This PRBS has an average value of 4.5.

The effective total sampling rate is thus 2 kHz-32 kHz divided by 4.5, giving 440 Hz – 7 kHz.

If all 24 channels of capacitive sensors are active, the channel conversion rate is thus $440 \text{ Hz}/24 = 18.3 \text{ Hz (Min)}$, $7 \text{ kHz}/24 = 296 \text{ Hz (Max)}$

Using the maximum MAF setting (18 remove 2), the maximum filtered channel output rate is $296 \text{ Hz}/18 = 16 \text{ Hz}$.

13.2 Sensor resolution

The capacitive sensor hardware in the STMPExxM31 devices has a sensitivity of 15 fF and a range of 512 steps giving it a dynamic range of 7.5 pF.

The impedance reading is the output of an internal MAF (median averaging filter). As up to 16 samples are taken for each reading, the impedance reading is the sum of 16 of 9-bit samples.

To allow maximum consistency, the 3 impedance readings are **always** 13-bit, whichever MAF setting is used.

The touch variance (TVR) and environmental variance (EVR) registers are specified in a 9-bit format. For comparison with the impedances, the TVR and EVR would be INTERNALLY shifted 4 bits up.

13.3 Auto-tuning

The capacitive sensor hardware in the STMPExxM31 devices has a sensitivity of 15 fF and a range of 512 steps giving it a dynamic range of 7.5 pF. This means that at any time, the device is able to sense a change in capacitance up to 7.5 pF. When the channel capacitance moves out of the 7.5 pF window, the auto tuning feature kicks in to ensure proper sensing operation.

Figure 15. Auto-tuning operation

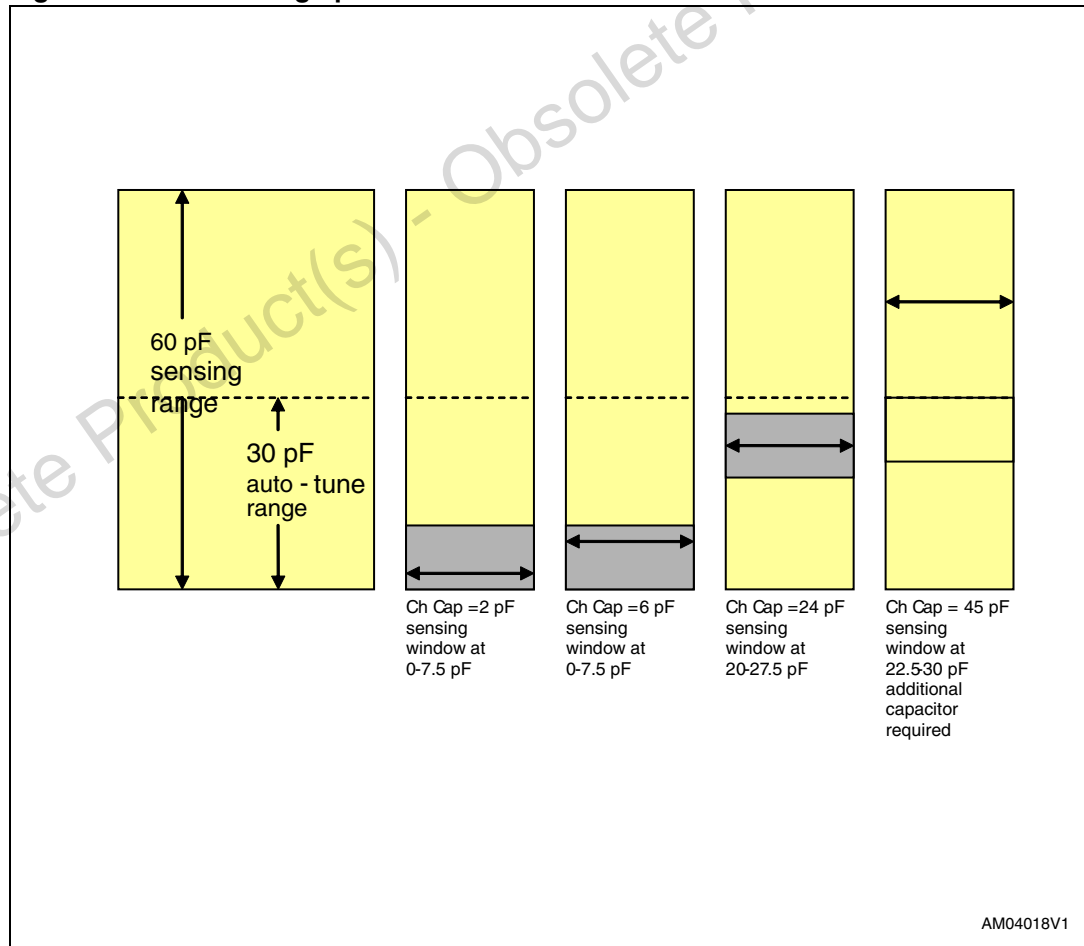

13.4 Locked impedance

Locked impedance is data available in channel data the moment 0x06 is written into “channel data type register”. Writing a different value into the “channel data type register” allows the locked impedance to be refreshed.

In actual application, software writes 0x06, reads locked impedance, writes 0x00, writes 0x06, and reads the next set of data.

For data type 0x04-0x05, data are constantly being refreshed, even as it is being accessed. If accessed slowly, the full set of data may have been sampled at significantly different time.

13.5 Calibration

Calibration event is performed in every period which is programmable from the calibration interval register (0x76). In each calibration event, 8 impedance samples are collected and averaged. The time period between samples is programmable from CAL_MOD (modeI register (0x77)).

Figure 16. Calibration

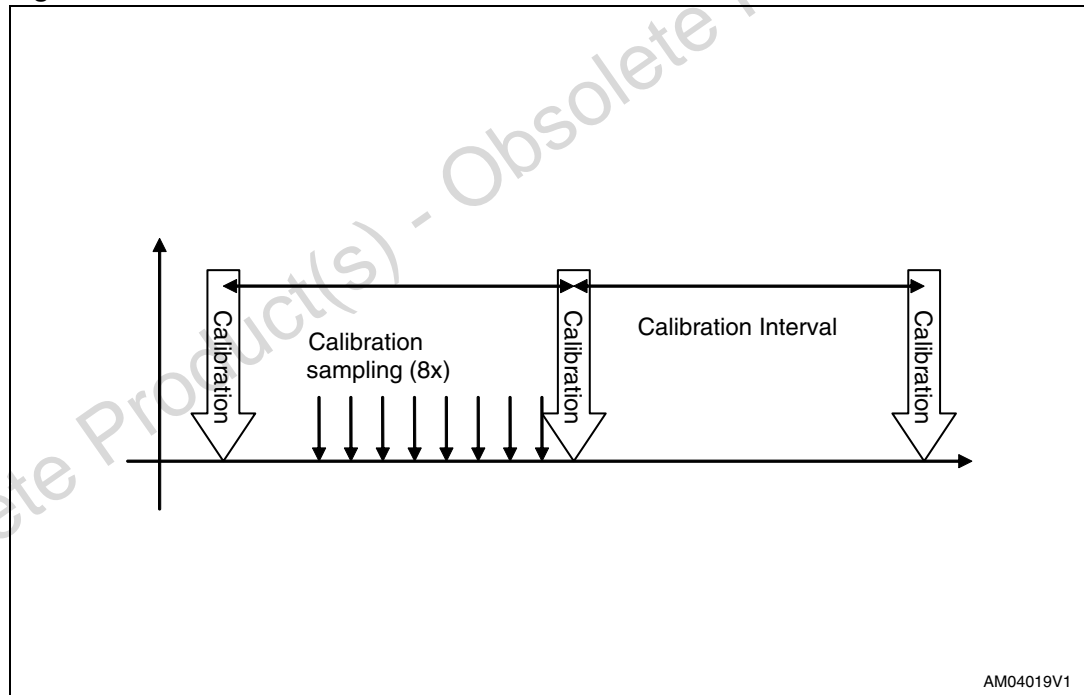

AM04019V1

CAP_SEN_CTRL

Capacitive sensor control register

Address: 0x70

Type: RW

Reset: 0x00

Description: This register controls the capacitive sensor’s operation.

| | | | | | | | |
|-------|-----|----|----|----|----|----|----------|
| 7 | 6 | 5 | 4 | 3 | 2 | 1 | 0 |
| CS_EN | HYS | | | | | | ForcedAT |
| RW | RW | RW | RW | RW | RW | RW | RW |
| 0 | 0 | 0 | 0 | 0 | 0 | 0 | 0 |

[7] CS_EN

Write ‘1’ to enable the capacitive sensor module
 Write ‘0’ to disable the capacitive sensor module

This bit should be set after all other touch sensor setting have been written. The changes in other setting when this bit is ‘1’ is not allowed.

If ratio-engine or key-filter unit is used, this bit should only be set, after ratio-engine and key-filter unit has been configured.

[6:1] HYS

TVR Hysteresis

When there is no touch, the value of TVR is used as threshold to determine touch condition.

If touch is detected, the touch detection threshold is changed to TVR-(HYS*4), hence the effective value of hysteresis is 0-256.

[0] ForcedAT

Write ‘1’ to initiate unconditional forced auto-tuning to center the static impedance value in the dynamic range. Prior sending this command, the calibration model must be set to mode ‘10’ with auto-tuning enabled.

Read ‘1’ if the auto-tuning process in progress

Read ‘0’ if the auto-tuning process has been completed.

It is required that upon start up the system, this command is called once.

When the auto-tuning is executed in the presence of finger on the sensor, the ‘touch’ status will become ‘no-touch’ after completion of the process. Once finger is removed, the auto-calibration will take care of this situation allowing the detection of next ‘touch’ event.

RATIO_ENG_REPT_CTRL

Ratio engine report control register

| | | | | | | | |
|------------|---|---|---|---------|---|---|---|
| 7 | 6 | 5 | 4 | 3 | 2 | 1 | 0 |
| MaxRptDrop | | | | MinDisp | | | |
| 0 | | | | 0 | | | |

Address: 0x71

Type: RW

Reset: 0x00

Description: This register controls the report of movement in the ration engine.

[7:4] MaxRptDrop

Maximum number of report that is dropped (due to displacement < MinDisp). If set to 0, all data will be reported

[3:0] MinDisp

Minimum displacement of slider position before a report is generated. If set to 0, all data will be reported

CH_SEL

Channel selection register

Address: 0x72-0x74

Type: RW

Reset: 0x000000

Description: This register configures the active capacitive sensing channels.

Bit 7-0 (0x72)

| | | | | | | | |
|----|----|----|----|----|----|----|----|
| 7 | 6 | 5 | 4 | 3 | 2 | 1 | 0 |
| S7 | S6 | S5 | S4 | S3 | S2 | S1 | S0 |
| RW | RW | RW | RW | RW | RW | RW | RW |
| 0 | 0 | 0 | 0 | 0 | 0 | 0 | 0 |

Bit 15-8 (0x73)

| | | | | | | | |
|-----|-----|-----|-----|-----|-----|----|----|
| 7 | 6 | 5 | 4 | 3 | 2 | 1 | 0 |
| S15 | S14 | S13 | S12 | S11 | S10 | S9 | S8 |
| RW | RW | RW | RW | RW | RW | RW | RW |
| 0 | 0 | 0 | 0 | 0 | 0 | 0 | 0 |

Bit 23-16 (0x74)

| | | | | | | | |
|-----|-----|-----|-----|-----|-----|-----|-----|
| 7 | 6 | 5 | 4 | 3 | 2 | 1 | 0 |
| S23 | S22 | S21 | S20 | S19 | S18 | S17 | S16 |
| RW | RW | RW | RW | RW | RW | RW | RW |
| 0 | 0 | 0 | 0 | 0 | 0 | 0 | 0 |

[7:0] S-X

Write '1' to enable the corresponding capacitive sensor channel

Write '0' to disable the corresponding capacitive sensor channel

Obsolete Product(s) - Obsolete Product(s)

CAL_INT

Calibration interval configuration register

Address: 0x76

Type: RW

Reset: 0x00

Description: This register configures the interval between successive calibrations.

| | | | | | | | |
|------------|----|----------|----|----|----|----|----|
| 7 | 6 | 5 | 4 | 3 | 2 | 1 | 0 |
| MULTIPLIER | | INTERVAL | | | | | |
| RW | RW | RW | RW | RW | RW | RW | RW |
| 0 | 0 | 0 | 0 | 0 | 0 | 0 | 0 |

[7:6] MULTIPLIER

Set the multiplier value for calibration interval set in Interval[5:0]

'00' for 8

'01' for 32

'10' for 128

'11' for 512

[5:0] INTERVAL

Set the calibration interval

Calibration interval :

= Interval[5:0]*10 ms * multiplier.

Obsolete Product(s) - Obsolete Product(s)

CAL_MOD**Calibration mode register****Address:** 0x77**Type:** RW**Reset:** 0x00**Description:** This register configures the way calibration samples are collected, and the model of calibration algorithm.

| | | | | | | | |
|------------|----|----|----|----|-------|----|--------|
| 7 | 6 | 5 | 4 | 3 | 2 | 1 | 0 |
| CSInterval | | | | | Model | | Cal_EN |
| RW | RW | RW | RW | RW | RW | RW | RW |
| 0 | 0 | 0 | 0 | 0 | 0 | 0 | 0 |

[7:3] CSInterval

Set the interval between samples in one calibration unit

Interval = CSInterval[4:0]*10ms

[2:1] IModel

Set the calibration model

'00' for normal auto-calibration

'10' for auto-calibration with auto-tuning. In this mode channel reference delay is not accessible from I2C. The system will perform auto-tuning if the impedance is moving out of dynamic range.

'01' is reserved

'11' is reserved

[0] Cal_EN

'1' to enable the auto-calibration

'0' to disable the auto-calibration

MAF_SET

Median averaging filter register

Address: 0x78

Type: RW

Reset: 0x00

Description: This register chooses the median averaging filter mode.

| | | | | | | | |
|----------|----|----|----|----|----------|----|--------|
| 7 | 6 | 5 | 4 | 3 | 2 | 1 | 0 |
| Reserved | | | | | MAF_Mode | | MAF_EN |
| RW | RW | RW | RW | RW | RW | RW | RW |
| 0 | 0 | 0 | 0 | 0 | 0 | 0 | 0 |

- [2:1] MAF_Mode
 - '00' to collect 10 samples, remove 2 samples
 - '01' to collect 18 samples, remove 2 samples
 - '10' to collect 20 samples, remove 4 samples

- [0] MAF_EN
 - '1' Enable the MAF
 - '0' Disable the MAF

DATA_TYPE

Data type definition register

Address: 0x7C

Type: RW

Reset: 0x00

Description: This register define the type of data to be accessed at capacitive channel data register.

| | | | | | | | |
|------|----|----|----|----|----|----|----|
| 7 | 6 | 5 | 4 | 3 | 2 | 1 | 0 |
| MODE | | | | | | | |
| RW | RW | RW | RW | RW | RW | RW | RW |
| 0 | 0 | 0 | 0 | 0 | 0 | 0 | 0 |

- [7:0] MODE
 - 0x01: TVR (9-bit)
 - 0x02: EVR (9-bit)
 - 0x03: Channel delay (6-bit)
 - 0x04: Impedance (13-bit)
 - 0x05: Calibrated impedance (13-bit)
 - 0x06: Locked impedance (13-bit)

CH_DATA-n

CHDATA-n registers (0-23)

Address: 0xC0-0xEF

Type: RW

Reset: 0x00

Description: Capacitive sensor channel data. The type of data represented by this register depends on the channel data type register (0x7C).

LSB, address : 0xC0 + (2*N), N = channel number

7 6 5 4 3 2 1 0

Channel N data [7:0]

| | | | | | | | |
|----|----|----|----|----|----|----|----|
| RW | RW | RW | RW | RW | RW | RW | RW |
| 0 | 0 | 0 | 0 | 0 | 0 | 0 | 0 |

MSB, address: 0xC0 + (2*N+1), N = channel number

7 6 5 4 3 2 1 0

Channel N data [15:8]

| | | | | | | | |
|----|----|----|----|----|----|----|----|
| RW | RW | RW | RW | RW | RW | RW | RW |
| 0 | 0 | 0 | 0 | 0 | 0 | 0 | 0 |

[16:0] Channel data

Display data selected by channel data type register (0x7C)

13.6 Definition of data accessible through channel data register

Table 14. Types of data accessible through the channel data register

| Data name | Definition |
|----------------------|---|
| TVR | TVR (touch variance register) is a threshold defined by system, of which, if the sense impedance changed by a magnitude more than the associated TVR, this channel is considered touched. The result of this comparison is directly accessible in the TOUCH_DET register. |
| EVR | EVR (environmental variance register) is a threshold defined by system, of which, if the sensed impedance changed by a magnitude less than the associated EVR, this is considered an environmental change and the device will calibrate the internal reference (calibrated impedance) accordingly. |
| Channel delay | Channel delay is used to tune the individual channel into effective measurement range. This field is 6-bit (0-63). Each bit in this field represents approximately 0.5 pF capacitance. |
| Impedance | <p>This field is a real time reflection of impedance measured at the corresponding channel. As capacitance is inversely proportional to impedance, this field reduces in value when capacitance on the channel increases.</p> <p>This field is of 13-bit length. The least significant 4 bits are results of internal processing and should not be used. The actual impedance data could be obtained by shifting the [Impedance] 4 bits to the right.</p> |
| Calibrated Impedance | <p>Read-only</p> <p>This field contains an internal reference used by the device to decide whether a touch has occurred. This value is adjusted regularly (calibration) by the device automatically.</p> |
| Locked impedance | <p>Data in this field is similar to data in impedance field, except that once this data type is chosen, the device maintains a complete set of impedance data in this field and stop refreshing it.</p> <p>This is useful for the application where it is required that all impedance data are sampled within a very short time.</p> |

13.7 Ratiometric engine

The STMPE16M31/24M31 support ratiometric slider/wheel implementation where a very high number of steps could be obtained from relatively few physical sensing channels. The high number of steps is derived from the ratio of capacitance sensed between neighboring channels.

To use the ratio engine, the system must:

- Define a range of channels (must be continuous) between 3-8 channels to be
- Used as slider/wheel input
- Select slider/wheel configuration
- Select noise filter setting
- Enable ratio engine
- After each set of data access, the RE bit in interrupt status register must be cleared.

Table 15. Ratiometric engine registers

| Address | Register name | Reset value | R/W | Description |
|---------|-----------------|-------------|-----|---------------------------------|
| 0x80 | RATIO_ENG_SET | 0x00 | RW | General setup of ratio engine |
| 0x81 | RATIO_ENG1_CFG | 0x00 | RW | Configuration of ratio engine 1 |
| 0x82 | RATIO_ENG2_CFG | 0x00 | RW | Configuration of ratio engine 2 |
| 0x83 | RATIO_ENG_STA | 0x00 | R | Status of ratio engine |
| 0x84 | RATIO_ENG1_DATA | 0x000000 | R | Output data of ratio engine 1 |
| 0x87 | RATIO_ENG2_DATA | 0x000000 | R | Output data of ratio engine 2 |

Figure 17. Configuration of ratio

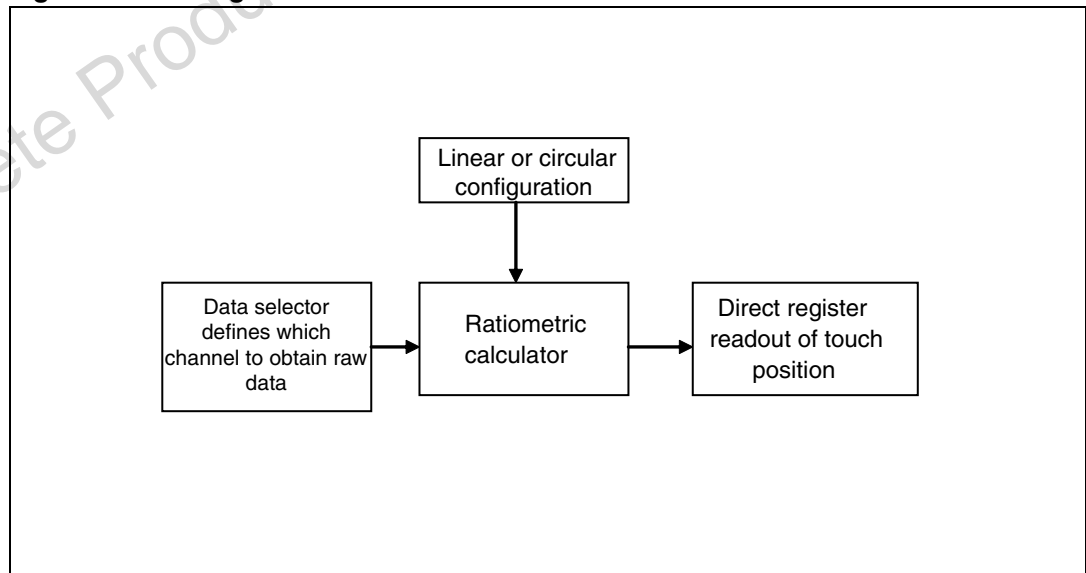

RATIO_ENG_SET

Ratio engine setup register

Address: 0x80

Type: RW

Reset: 0x00

Description: Operation setup of ratio engine.

| | | | | | | | |
|----------|----------|-------------|-------------|------|------|-----|-----|
| 7 | 6 | 5 | 4 | 3 | 2 | 1 | 0 |
| RESERVED | DATAMODE | RE2FilterEn | RE1FilterEn | CFG2 | CFG2 | EN2 | EN1 |
| RW | RW | RW | RW | RW | RW | RW | RW |
| 0 | 0 | 0 | 0 | 0 | 0 | 0 | 0 |

[7] RESERVED

[6] DATAMODE

Setting of data presentation

'1' to display 1 byte position data in the first byte of RE1_POS and RE2_POS continuously. The old data will be overwritten. In this mode, when touch is detected in the slider, interrupt is issued and host can read the data in its own rate. Only position data is available (8 bits), movement and time-stamp data are not available.

'0' to enable data-buffering. Position, movement and time-stamp are available.

[5] RE2FilterEn

Ratio engine 2 noise filter

'1' to enable the filter

'0' to disable the filter

[4] RE1FilterEn

Ratio engine 1 noise filter

'1' to enable the filter

'0' to disable the filter

[3] CFG2

Ratio engine 2 setting

'1' for rotator/wheel configuration

'0' for linear/slider configuration

[2] CFG1

Ratio engine 1 setting

'1' for rotator/wheel configuration

'0' for linear/slider configuration

[1] EN2

'1' to enable ratio engine 2

'0' to enable ratio engine 1

[0] EN1

'1' to enable ratio engine 2

'0' to enable ratio engine 1

RATIO_ENG-n_CFG

Ratio engine-1,-2 registers

Address: 0x81, 0x82

Type: RW

Reset: 0x00

Description: Configure the channels used in ratio engine 1 and 2.

| | | | | | | | |
|-------|----|----|----|-------|----|----|----|
| 7 | 6 | 5 | 4 | 3 | 2 | 1 | 0 |
| RANGE | | | | START | | | |
| RW | RW | RW | RW | RW | RW | RW | RW |
| 0 | 0 | 0 | 0 | 0 | 0 | 0 | 0 |

[7:5] RANGE:

'Number of channels used in ratio engine. Maximum is 8 channels. The number represent number of channels used - 1

[4:0] START:

Define the starting channel used in ratio engine. This number represent the channel number

Figure 18. Configuration of ratio engine input

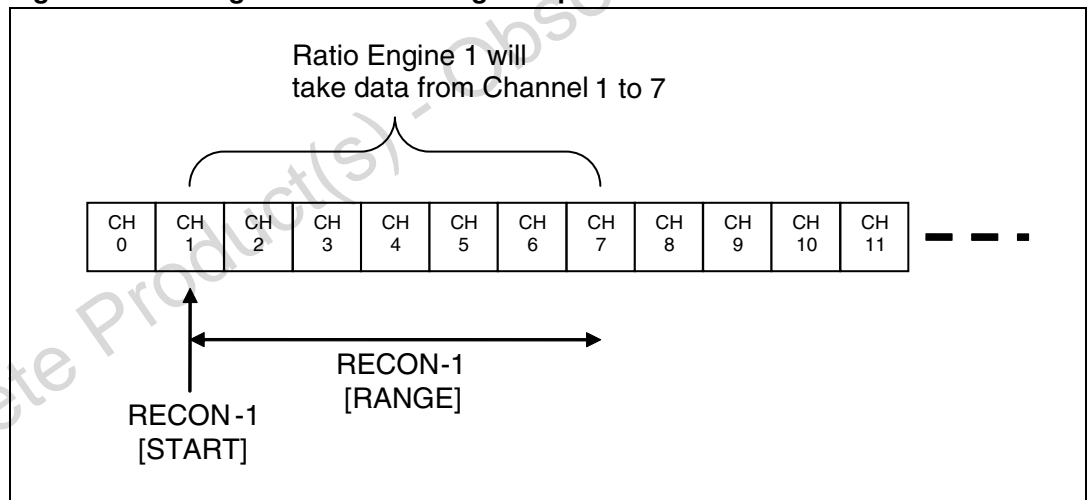

RATIO_ENG_STA

Ratio engine status register

Address: 0x83

Type: R

Reset: 0x00

Description: This register report the event of multi touch in the ratio engine.

| | | | | | | | |
|----------|----|----|----|----|----|-----|-----|
| 7 | 6 | 5 | 4 | 3 | 2 | 1 | 0 |
| RESERVED | | | | | | MT2 | MT1 |
| RW | RW | RW | RW | RW | RW | RW | RW |
| 0 | 0 | 0 | 0 | 0 | 0 | 0 | 0 |

[7:2] RESERVED

[1] MT2

Read '1' when more than 1 touch is detected in Ratio Engine 2

[0] MT1

Read '1' when more than 1 touch is detected in Ratio Engine 1

RATIO_ENG_DATA-n (engineering samples)

Ratio engine -1, -2 data registers

Address: 0x84-0x86, 0x87-0x89

Type: R

Reset: 0x0000

Description: Position of the touch as calculation output of ratio engine1 and 2. Data is organized as a "packet" of 3 bytes. The data is backed by 4-level of buffer.

1st byte [7:0]

| | | | | | | | |
|----------|----|----|----|----|----|----|----|
| 7 | 6 | 5 | 4 | 3 | 2 | 1 | 0 |
| POS[7:0] | | | | | | | |
| RW | RW | RW | RW | RW | RW | RW | RW |
| 0 | 0 | 0 | 0 | 0 | 0 | 0 | 0 |

2nd byte [15:8]

| | | | | | | | |
|----------|----|----|----|----|----|----------|----|
| 7 | 6 | 5 | 4 | 3 | 2 | 1 | 0 |
| MOV[5:0] | | | | | | POS[9:8] | |
| RW | RW | RW | RW | RW | RW | RW | RW |
| 0 | 0 | 0 | 0 | 0 | 0 | 0 | 0 |

3rd byte [23:16]

| | | | | | | | |
|-------|-----------------|----|----|----|----|----|----|
| 7 | 6 | 5 | 4 | 3 | 2 | 1 | 0 |
| Touch | TIME_STAMP[6:0] | | | | | | |
| RW | RW | RW | RW | RW | RW | RW | RW |
| 0 | 0 | 0 | 0 | 0 | 0 | 0 | 0 |

[9:0] POS
Position of the touch in ratio engine sensors

[15:10] MOV
Movement of the touch location as a function of POS1 – POS0, where POS1 is current position and POS0 is position before.

[22:16] TIME_STAMP
Delay between current and previous samples in unit of time

[23] TOUCH
This bit indicates the status of the finger
‘1’ indicates a finger touches the slider/wheel
‘0’ indicates no touch is detected

Ratio Engine generates an interrupt on the event of transition from touch to no touch. When host receive the interrupt, it needs to check this bit to verify the presence of the finger. When touch is detected, the data in RE1_POS and RE2_POS are valid, otherwise it means finger is lifted up

RATIO_ENG_DATA_n (production silicon)

Ratio engine -1, -2 data register

Address: 0x84-0x86, 0x87-0x89

Type: R

Reset: 0x0000

Description: Position of the touch as calculation output of Ratio Engine 1 and 2 Data is organized as a "packet" of 3 bytes. The data is backed by 4-level of buffer

1st byte [7:0]

| | | | | | | | |
|----------|----|----|----|----|----|----|----|
| 7 | 6 | 5 | 4 | 3 | 2 | 1 | 0 |
| POS[7:0] | | | | | | | |
| RW | RW | RW | RW | RW | RW | RW | RW |
| 0 | 0 | 0 | 0 | 0 | 0 | 0 | 0 |

2nd byte [15:8]

| | | | | | | | |
|----------|----|----|----|----|----|----|----|
| 15 | 14 | 13 | 12 | 11 | 10 | 9 | 8 |
| MOV[5:0] | | | | | | | |
| RW | RW | RW | RW | RW | RW | RW | RW |
| 0 | 0 | 0 | 0 | 0 | 0 | 0 | 0 |

3rd byte [23:16]

| | | | | | | | |
|-------|-----------------|----|----|----|----|----|----|
| 23 | 22 | 21 | 20 | 19 | 18 | 17 | 16 |
| TOUCH | TIME_STAMP[6:0] | | | | | | |
| RW | RW | RW | RW | RW | RW | RW | RW |
| 0 | 0 | 0 | 0 | 0 | 0 | 0 | 0 |

[7:0] POS:
Position of the touch in ratio engine sensors.

[15:8] MOV:
Movement of the touch location as a function of POS1 – POS0, where POS1 is current position and POS0 is position before.

[23:16] TIME_STAMP:
Delay between current and previous samples in unit of time.
Each bit is 8ms (if MAF is enabled), or 1/4ms (if MAF is not enabled).

14 Touchkey controller

The touchkey controller processes raw capacitance measurement data into “touch/no-touch” boolean data for easy usage. The 2 key filter units provides additional flexibility by allowing the system to define a maximum number of keys that could be detected and considered active, based on the amount of impedance change detected.

Table 16. Touchkey controller registers

| Address | Register name | Reset value | R/W | Description |
|---------|-----------------|-------------|-----|--|
| 0x90 | KEY_FILT_CTRL | 0x00 | R/W | General key filter control |
| 0x92 | KEY_FILT_GROUP1 | 0x00000000 | R/W | Define channels included in key filter group 1 |
| 0x96 | KEY_FILT_GROUP2 | 0x00000000 | R/W | Define channels included in key filter group 2 |
| 0x9A | KEY_FILT_DATA | 0x00000000 | R | Filtered touchkey data |
| 0xB4 | TOUCH_DET | 0x00000000 | R | Touch detection register (real time) |

Figure 19. Data flow in touchkey controller

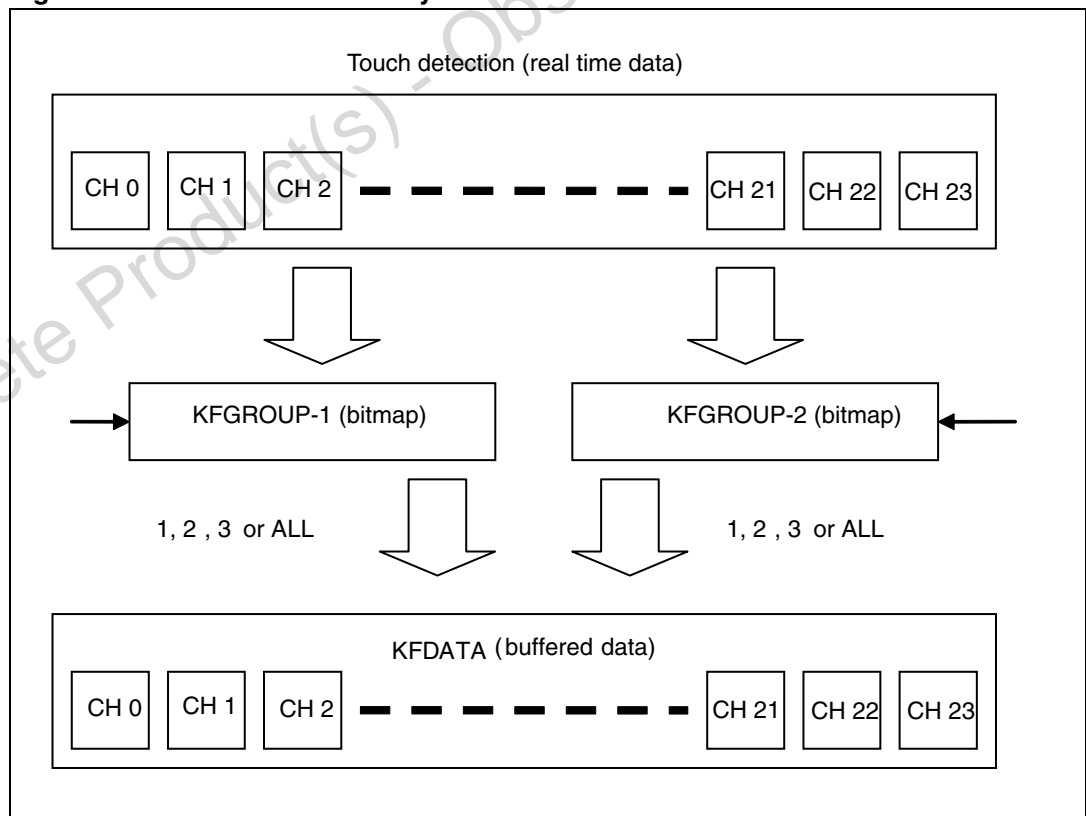

KEY_FILT_CFG

Key filter unit configuration register

Address: 0x90
Type: RW
Reset: 0x00
Description: Setting of key filter unit.

| | | | | | | | |
|----------|----|----|----|-----------|----|-----------|----|
| 7 | 6 | 5 | 4 | 3 | 2 | 1 | 0 |
| RESERVED | | | | Mode_KFU2 | | Mode_KFU1 | |
| RW | RW | RW | RW | RW | RW | RW | RW |
| 0 | 0 | 0 | 0 | 0 | 0 | 0 | 0 |

[7:4] RESERVED
 Position of the touch in ratio engine sensors

[3:2] Mode_KFU2
 '00' for no filter
 '01' for 1 highest impedance change filter in group 2
 '10' for 2 highest impedance change filter in group 2
 '11' for 3 highest impedance change filter in group 2

[1:0] Mode_KFU1
 '00' for no filter
 '01' for 1 highest impedance change filter in group 1
 '10' for 2 highest impedance change filter in group 1
 '11' for 3 highest impedance change filter in group 1

KEY_FILT_GROUP-n

KFGROUP-1, KFGROUP-2 registers

Address: 0x92-0x94 (KeyFilterMask1), 0x96-0x98 (KeyFilterMask2)
Type: R/W
Reset: 0x000000
Description: Configure the channels included in a group of key filter unit.

Bit 7-0 (0x92 for KFGROUP-1, 0x96 for KFGROUP-2)

| | | | | | | | |
|----|----|----|----|----|----|----|----|
| 7 | 6 | 5 | 4 | 3 | 2 | 1 | 0 |
| S7 | S6 | S5 | S4 | S3 | S2 | S1 | S0 |
| RW | RW | RW | RW | RW | RW | RW | RW |
| 0 | 0 | 0 | 0 | 0 | 0 | 0 | 0 |

Bit 15-8 (0x93 for KFGROUP-1, 0x97 for KFGROUP-2)

| 7 | 6 | 5 | 4 | 3 | 2 | 1 | 0 |
|-----|-----|-----|-----|-----|-----|----|----|
| S15 | S14 | S13 | S12 | S11 | S10 | S9 | S8 |
| RW | RW | RW | RW | RW | RW | RW | RW |
| 0 | 0 | 0 | 0 | 0 | 0 | 0 | 0 |

Bit 23-16 (0x94 for KFGROUP-1, 0x98 for KFGROUP-2)

| 7 | 6 | 5 | 4 | 3 | 2 | 1 | 0 |
|-----|-----|-----|-----|-----|-----|-----|-----|
| S23 | S22 | S21 | S20 | S19 | S18 | S17 | S16 |
| RW | RW | RW | RW | RW | RW | RW | RW |
| 0 | 0 | 0 | 0 | 0 | 0 | 0 | 0 |

[23:0] S-X

Write '1' to include the corresponding channel in a group of Key Filter Unit

KEY_FILT_DATA**Key filter data register****Address:** 0x9A-0x9C**Type:** RW**Reset:** 0x000000

Description: Represent the status of (touch/no-touch), after being filtered by key filter unit. This register is always active and key status can be accessed from this register regardless of key filter unit activity.

Bit 7-0 (0x9A)

| 7 | 6 | 5 | 4 | 3 | 2 | 1 | 0 |
|----|----|----|----|----|----|----|----|
| S7 | S6 | S5 | S4 | S3 | S2 | S1 | S0 |
| RW | RW | RW | RW | RW | RW | RW | RW |
| 0 | 0 | 0 | 0 | 0 | 0 | 0 | 0 |

Bit 15-8 (0x9B)

| 7 | 6 | 5 | 4 | 3 | 2 | 1 | 0 |
|-----|-----|-----|-----|-----|-----|----|----|
| S15 | S14 | S13 | S12 | S11 | S10 | S9 | S8 |
| RW | RW | RW | RW | RW | RW | RW | RW |
| 0 | 0 | 0 | 0 | 0 | 0 | 0 | 0 |

Bit 23-16 (0x9C)

| | | | | | | | |
|-----|-----|-----|-----|-----|----|-----|-----|
| 7 | 6 | 5 | 4 | 3 | 2 | 1 | 0 |
| S23 | S22 | S21 | S20 | S18 | S2 | S17 | S16 |
| RW | RW | RW | RW | RW | RW | RW | RW |
| 0 | 0 | 0 | 0 | 0 | 0 | 0 | 0 |

[23:0] S-X

Read '1' if the corresponding sensor channel status is 'touched'.

TOUCH_DET

Touchkey detection register

Address: 0xB4-B6

Type: RW

Reset: 0x000000

Description: Represents the real time status of the touchkey input. This is a direct result of comparison of sensed impedance with calibrated impedance (taking in account of hysteresis). This data is not buffered.

Bit 7-0 (0xB4)

| | | | | | | | |
|----|----|----|----|----|----|----|----|
| 7 | 6 | 5 | 4 | 3 | 2 | 1 | 0 |
| S7 | S6 | S5 | S4 | S3 | S2 | S1 | S0 |
| RW | RW | RW | RW | RW | RW | RW | RW |
| 0 | 0 | 0 | 0 | 0 | 0 | 0 | 0 |

[S23:S16]

Bit 15-8 (0xB5)

| | | | | | | | |
|-----|-----|-----|-----|-----|-----|----|----|
| 7 | 6 | 5 | 4 | 3 | 2 | 1 | 0 |
| S15 | S14 | S13 | S12 | S11 | S10 | S9 | S8 |
| RW | RW | RW | RW | RW | RW | RW | RW |
| 0 | 0 | 0 | 0 | 0 | 0 | 0 | 0 |

[S15:S6]

Bit 23-16 (0xB6)

| 7 | 6 | 5 | 4 | 3 | 2 | 1 | 0 |
|-----|-----|-----|-----|-----|-----|-----|-----|
| S23 | S22 | S21 | S20 | S19 | S18 | S17 | S16 |
| RW | RW | RW | RW | RW | RW | RW | RW |
| 0 | 0 | 0 | 0 | 0 | 0 | 0 | 0 |

[7:0] S-X

Read '1' if the corresponding sensor channel status is 'touched'

Obsolete Product(s) - Obsolete Product(s)

15 Maximum rating

Stressing the device above the rating listed in the “Absolute maximum ratings” table may cause permanent damage to the device. These are stress ratings only and operation of the device at these or any other conditions above those indicated in the operating sections of this specification is not implied. Exposure to absolute maximum rating conditions for extended periods may affect device reliability.

Table 17. Absolute maximum ratings

| Symbol | Parameter | Value | Unit |
|------------------------|---------------------------------------|-------|------|
| V _{CC} | Supply voltage | 2.5 | V |
| V _{IO} | GPIO supply voltage | 6 | V |
| V _{ESD (HBM)} | ESD protection on each GPIO/TOUCH pin | 8 | KV |
| V _{ESD (MM)} | ESD protection on all pins | 200 | V |

15.1 Recommended operating conditions

Table 18. Recommended operating conditions

| Symbol | Parameter | Value | | Unit |
|-----------------|---------------------|---------|---------|------|
| | | Min | Max | |
| V _{CC} | Supply voltage | 1.65 | 1.95 | V |
| V _{IO} | GPIO supply voltage | 2.7 | 5.5 | V |
| GPIO | GPIO input voltage | GND-0.5 | VIO+0.5 | V |

16 DC electrical characteristics

-40 to 85 °C unless stated otherwise.

Table 19. DC electrical characteristics

| Symbol | Parameter | Test conditions | Value | | | Unit |
|------------------------|--|--|---------------------|-----|------------------------|------|
| | | | Min | Typ | Max | |
| V _{CC} | Core supply voltage | | 1.65 | - | 1.95 | V |
| V _{IO} | IO supply voltage | | 2.7 | - | 5.5 | V |
| I _{active} | ACTIVE current | 2 MHz/32 sensor clock, slider engine active, 25 °C | - | 600 | 800 | μA |
| I _{active} | ACTIVE current | 2 MHz/32 sensor clock, slider engine active, -40 to 85°C | - | - | 1000 | μA |
| I _{active} | ACTIVE current | 2 MHz/32 sensor clock, with/without touch, key only, 25°C | - | 400 | - | μA |
| I _{sleep} | SLEEP current | 2 MHz/32 sensor clock, without touch, -40 to 85°C | - | 50 | 75 | μA |
| I _{hibernate} | HIBERNATE current | No sensing capability. Hotkey available, 25°C | - | 5 | 8 | μA |
| I _{hibernate} | HIBERNATE current | No sensing capability. Hotkey available, -40 to 85°C | - | - | 20 | μA |
| V _{IL} | Input voltage low state (RESET/A0/A1/I2C) | V _{CC} = 1.8 V | -0.3V | - | 0.35V _{CC} | V |
| V _{IH} | Input voltage high state (RESET/A0/A1/I2C) | V _{CC} = 1.8 V | 0.75V _c | - | V _{CC} +0.3 V | V |
| V _{IL} | Input voltage low state (GPIO) | V _{IO} = 2.7 - 5.5 V | -0.3V | - | 0.35V _{IO} | V |
| V _{IH} | Input voltage high state (GPIO) | V _{IO} = 2.7 - 5.5 V | 0.65V _{IO} | - | V _{IO} +0.3 V | V |
| V _{OL} | Output voltage low state (GPIO) | V _{IO} = 2.7 - 5.5 V, I _{OL} = 12 mA | -0.3V | - | 0.25V _{IO} | V |
| V _{OH} | Output voltage high state (GPIO) | V _{IO} = 2.7 - 5.5 V, I _{OL} = 12 mA | 0.75V _{IO} | - | V _{IO} +0.3 V | V |
| I _{leakage} | Input leakage on all GPIO/touch pins | V _{IO} = 5.5 V, V _{CC} powered by V _{IO} , I/O set as input, 5.5 V applied to I/O | - | - | 100 | nA |

16.1 Capacitive sensor specification

-40 to 85 °C unless stated otherwise.

Table 20. Capacitive sensor specification

| Symbol | Parameter | Test conditions | Value | | | Unit |
|--------|--------------------------------|--|-------|-----|-----|------|
| | | | Min | Typ | Max | |
| Cs | Capacitive sensor sensitivity | V _{IO} = 2.7 - 5.5 V, internal V _{REG} | 12 | 16 | 20 | fF |
| Csvr | Variance of Cs across channels | V _{IO} = 2.7 - 5.5 V, internal V _{REG} | - | 10 | - | % |

17 Application information

17.1 Average current consumption

In application, it is unlikely that touch event occurs 100% of the time. Power consumption for STMPExxM31 can be reduced significantly with the proper use of the available device Sleep mode. The device can be programmed into Sleep mode upon detecting of the finger lift. During the Sleep mode, upon detecting a touch, STMPExxM31 goes from Sleep to Active mode after 15 ms.

As such, for an example touch profiles in *Figure 20* below, the Average current consumption over the 6 seconds is:

$$= [(0.185+0.285+0.285) * 400 \mu\text{A} + (5.245 * 50 \mu\text{A})]/6$$

$$= 94 \mu\text{A}.$$

Figure 20. Average current consumption

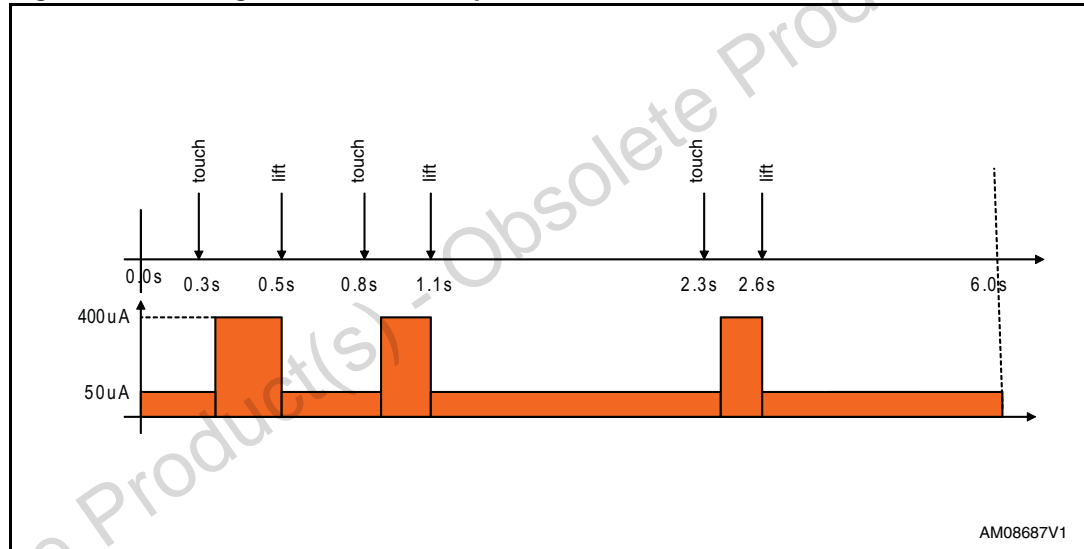

18 Package mechanical data

In order to meet environmental requirements, ST offers these devices in different grades of ECOPACK® packages, depending on their level of environmental compliance. ECOPACK® specifications, grade definitions and product status are available at: www.st.com. ECOPACK® is an ST trademark.

Obsolete Product(s) - Obsolete Product(s)

Figure 21. Package outline for QFN40 (5 x 5 mm) - pitch 0.4 mm

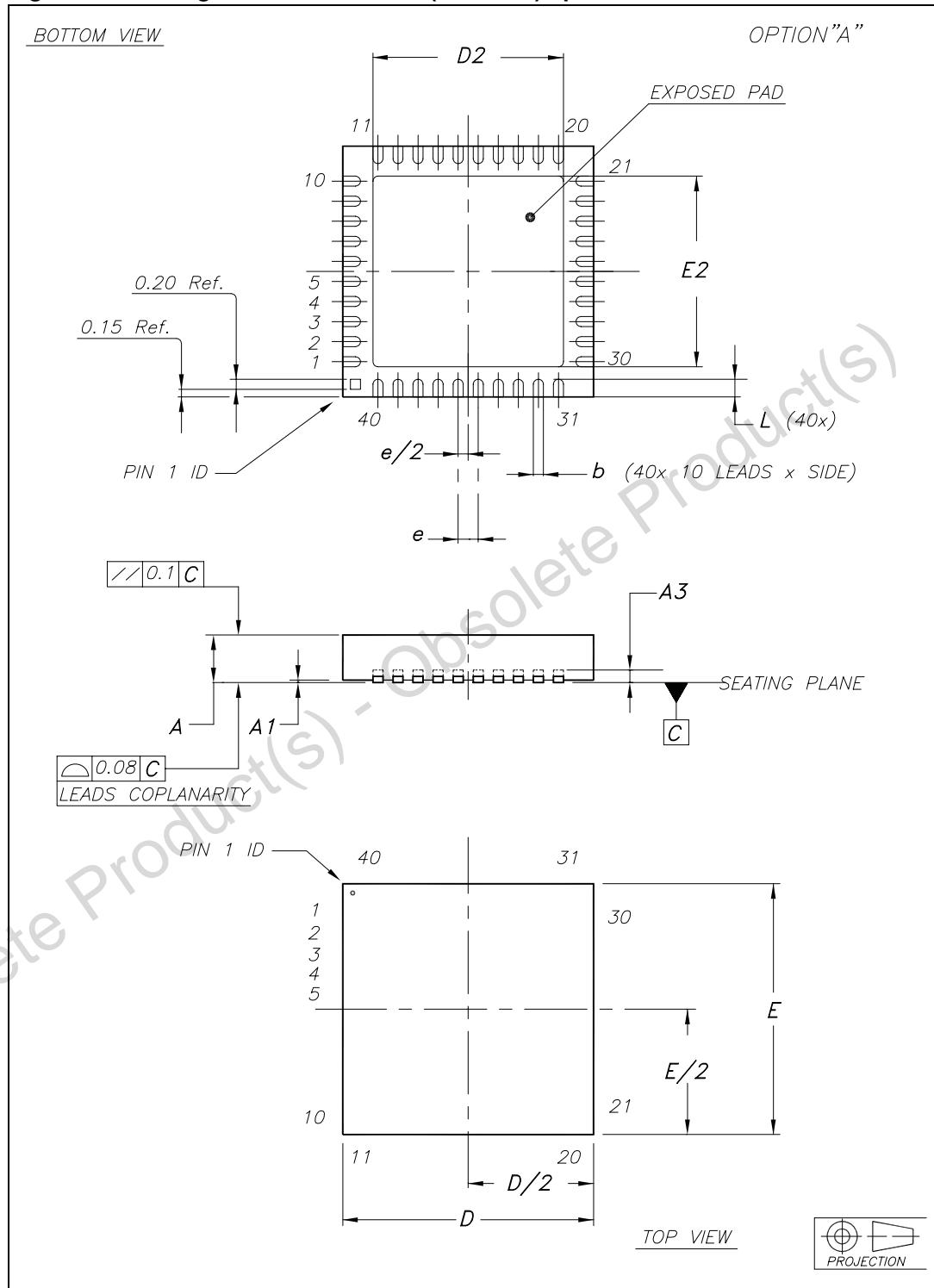

Table 21. Package mechanical data for QFN40 (5 x 5 mm) - pitch 0.4 mm

| Symbol | Millimeters | | |
|--------|-------------|--------|------|
| | Min | Typ | Max |
| A | 0.80 | 0.85 | 0.90 |
| A1 | 0 | 0.02 | 0.05 |
| A3 | - | -0.203 | - |
| b | 0.15 | 0.20 | 0.25 |
| D | 4.90 | 5 | 5.10 |
| D2 | 3.70 | 3.80 | 3.90 |
| E | 4.90 | 5 | 5.10 |
| E2 | 3.70 | 3.80 | 3.90 |
| e | - | 0.40 | - |
| L | 0.25 | 0.35 | 0.45 |

Figure 22. QFN40 recommended footprint without ground pad VIA

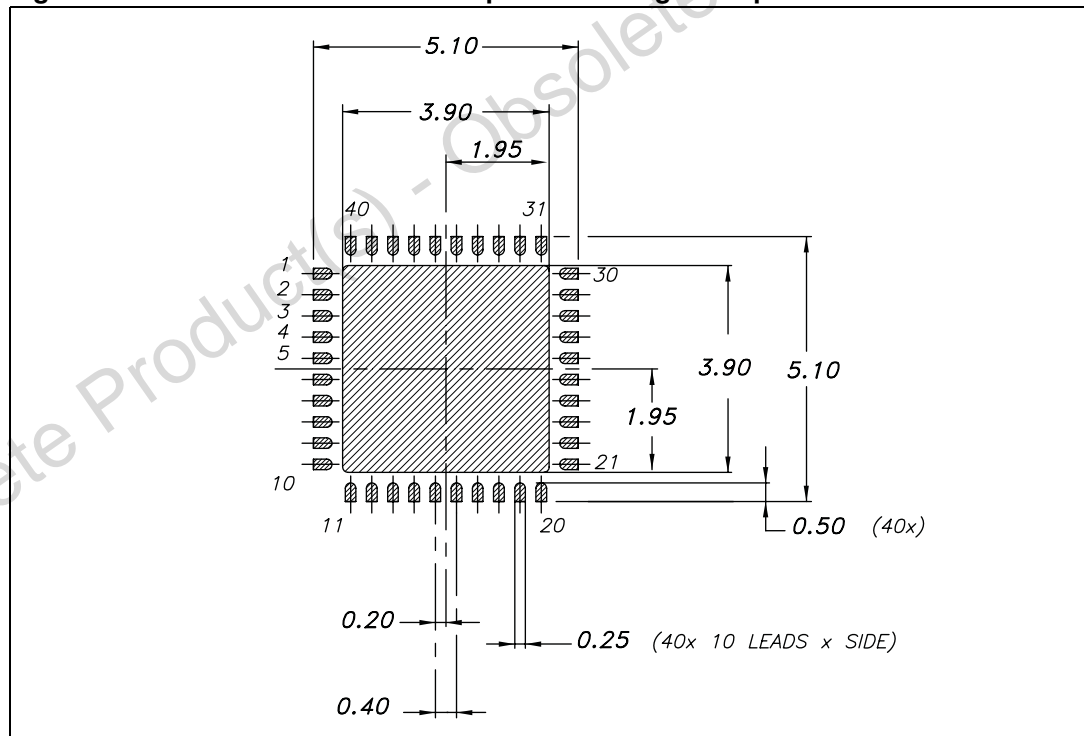

Figure 23. QFN40 recommended footprint with ground pad VIA

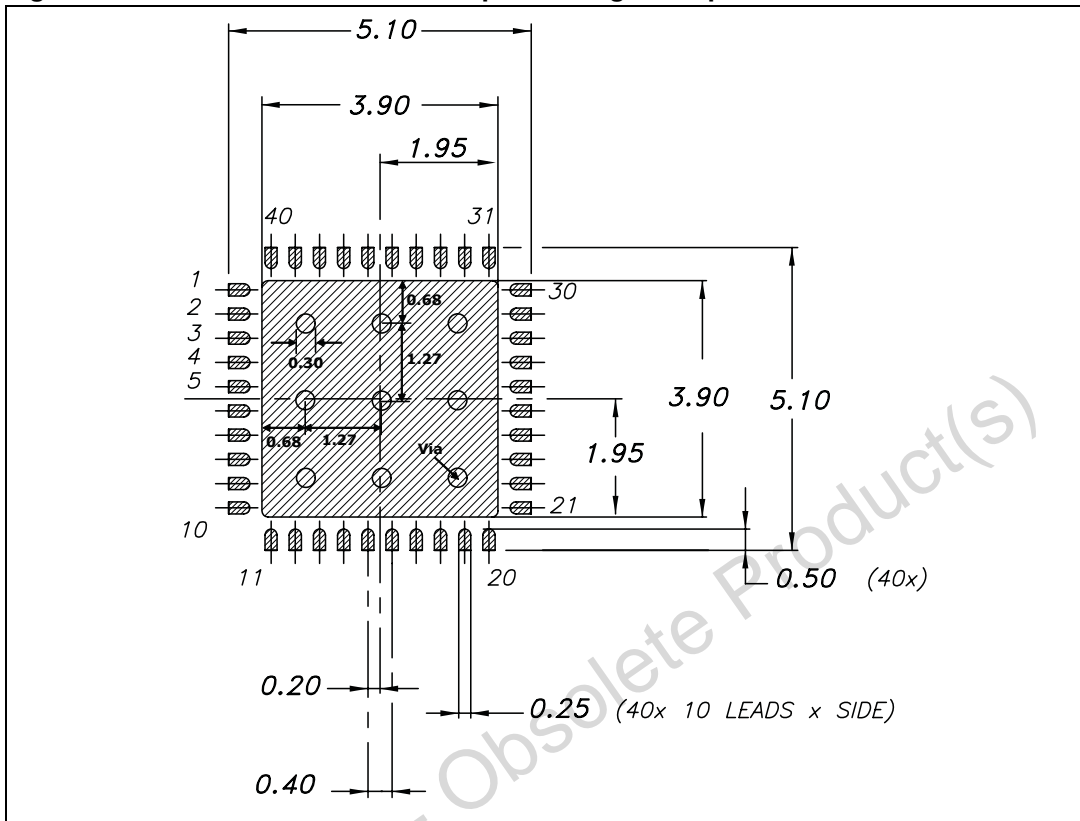

Figure 25. Reel information for QFN40 (5 x 5 mm) - pitch 0.4 mm

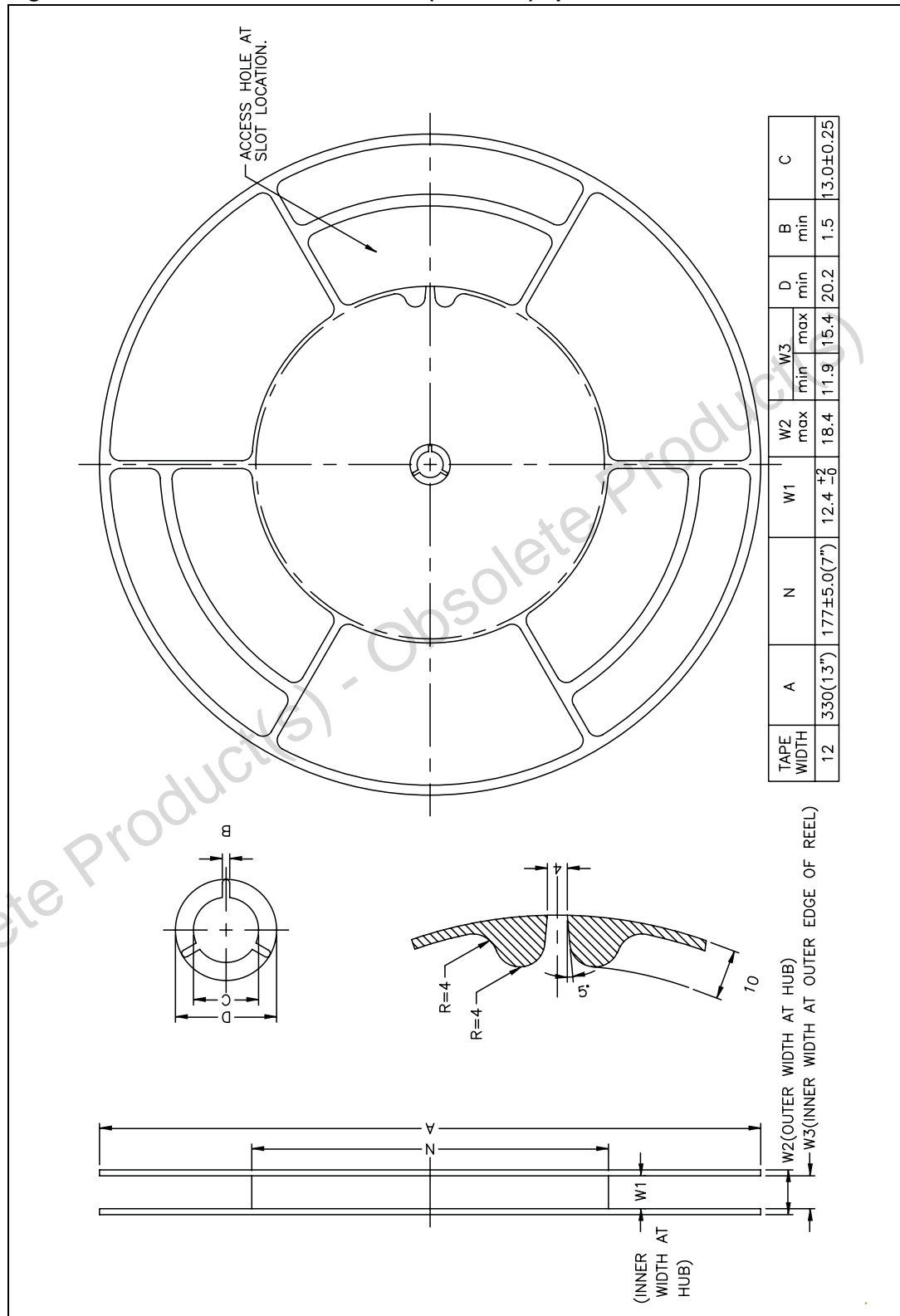

Table 22. Package mechanical data for QFN32 (4 x 4 mm) - pitch 0.4 mm

| Symbol | Millimeters | | |
|--------|-------------|------|------|
| | Min | Typ | Max |
| A | 0.70 | - | 0.90 |
| A1 | 0.03 | 0.05 | 0.08 |
| A3 | - | 0.20 | - |
| b | 0.19 | 0.21 | 0.28 |
| D | 3.85 | 4.00 | 4.15 |
| D2 | 2.70 | 2.80 | 2.90 |
| E | 3.85 | 4.00 | 4.15 |
| E2 | 2.70 | 2.80 | 2.90 |
| e | - | 0.40 | - |
| e/2 | - | 0.20 | - |
| L | 0.10 | 0.20 | 0.30 |

Figure 27. Footprint recommendation for QFN32 (4 x 4 mm) - pitch 0.4 mm

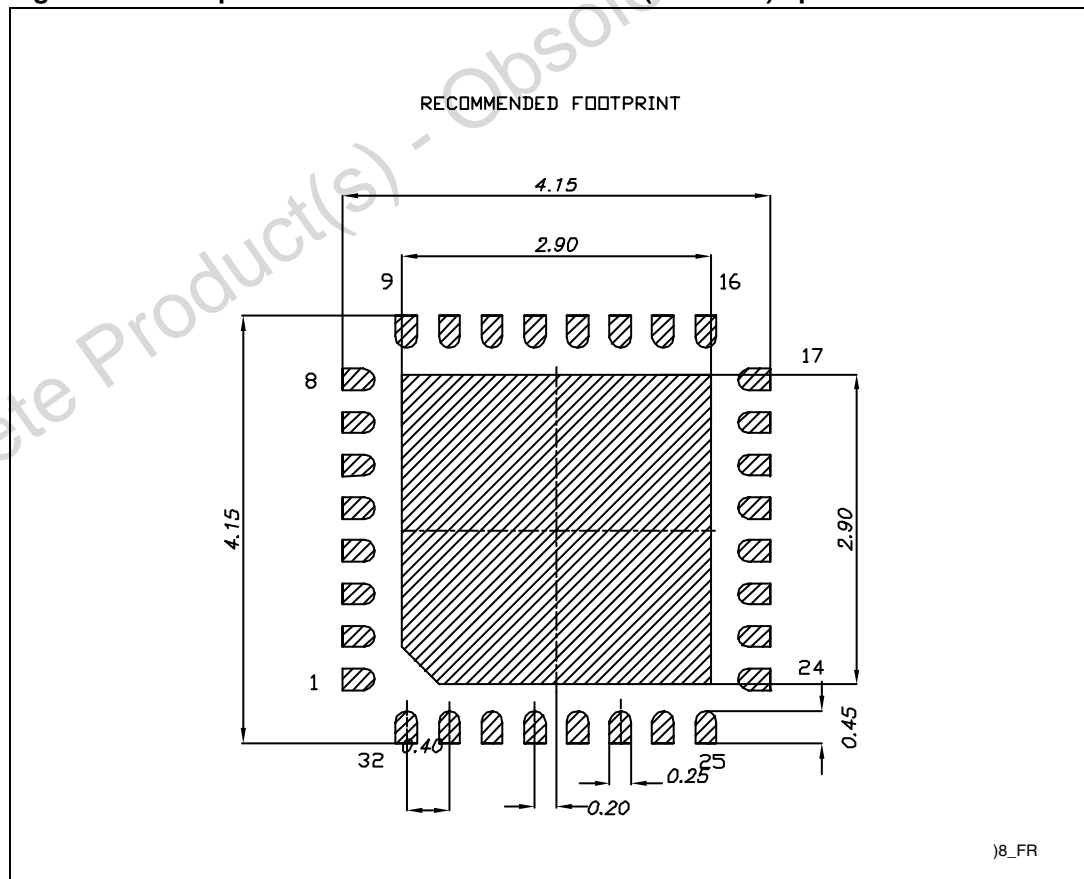
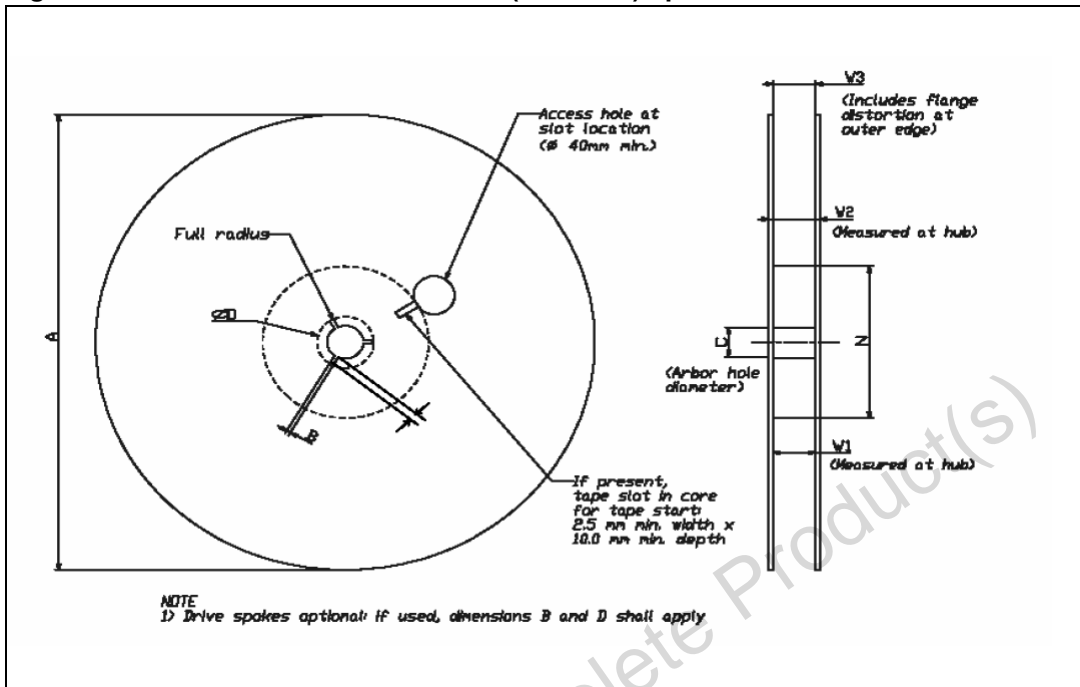

Figure 28. Reel information for QFN32 (4 x 4 mm) - pitch 0.4 mm



Obsolete Product(s) - Obsolete Product(s)

19 Revision history

Table 23. Document revision history

| Date | Revision | Changes |
|-------------|----------|---|
| 02-Nov-2009 | 1 | Initial release. |
| 08-Feb-2010 | 2 | Document status promoted from preliminary data to datasheet. Updated: low operating current values, Section 2 , Section 7 and Section 13 . |
| 12-Jan-2011 | 3 | Updated: Section 2 , Table 19 , Section 13.1 , QFN40 (5x5 mm) and QFN32 (4 x 4 mm) package mechanical data. |
| 18-Apr-2011 | 4 | Updated: Table 19 |

Please Read Carefully:

Information in this document is provided solely in connection with ST products. STMicroelectronics NV and its subsidiaries ("ST") reserve the right to make changes, corrections, modifications or improvements, to this document, and the products and services described herein at any time, without notice.

All ST products are sold pursuant to ST's terms and conditions of sale.

Purchasers are solely responsible for the choice, selection and use of the ST products and services described herein, and ST assumes no liability whatsoever relating to the choice, selection or use of the ST products and services described herein.

No license, express or implied, by estoppel or otherwise, to any intellectual property rights is granted under this document. If any part of this document refers to any third party products or services it shall not be deemed a license grant by ST for the use of such third party products or services, or any intellectual property contained therein or considered as a warranty covering the use in any manner whatsoever of such third party products or services or any intellectual property contained therein.

UNLESS OTHERWISE SET FORTH IN ST'S TERMS AND CONDITIONS OF SALE ST DISCLAIMS ANY EXPRESS OR IMPLIED WARRANTY WITH RESPECT TO THE USE AND/OR SALE OF ST PRODUCTS INCLUDING WITHOUT LIMITATION IMPLIED WARRANTIES OF MERCHANTABILITY, FITNESS FOR A PARTICULAR PURPOSE (AND THEIR EQUIVALENTS UNDER THE LAWS OF ANY JURISDICTION), OR INFRINGEMENT OF ANY PATENT, COPYRIGHT OR OTHER INTELLECTUAL PROPERTY RIGHT.

UNLESS EXPRESSLY APPROVED IN WRITING BY AN AUTHORIZED ST REPRESENTATIVE, ST PRODUCTS ARE NOT RECOMMENDED, AUTHORIZED OR WARRANTED FOR USE IN MILITARY, AIR CRAFT, SPACE, LIFE SAVING, OR LIFE SUSTAINING APPLICATIONS, NOR IN PRODUCTS OR SYSTEMS WHERE FAILURE OR MALFUNCTION MAY RESULT IN PERSONAL INJURY, DEATH, OR SEVERE PROPERTY OR ENVIRONMENTAL DAMAGE. ST PRODUCTS WHICH ARE NOT SPECIFIED AS "AUTOMOTIVE GRADE" MAY ONLY BE USED IN AUTOMOTIVE APPLICATIONS AT USER'S OWN RISK.

Resale of ST products with provisions different from the statements and/or technical features set forth in this document shall immediately void any warranty granted by ST for the ST product or service described herein and shall not create or extend in any manner whatsoever, any liability of ST.

ST and the ST logo are trademarks or registered trademarks of ST in various countries.

Information in this document supersedes and replaces all information previously supplied.

The ST logo is a registered trademark of STMicroelectronics. All other names are the property of their respective owners.

© 2011 STMicroelectronics - All rights reserved

STMicroelectronics group of companies

Australia - Belgium - Brazil - Canada - China - Czech Republic - Finland - France - Germany - Hong Kong - India - Israel - Italy - Japan - Malaysia - Malta - Morocco - Philippines - Singapore - Spain - Sweden - Switzerland - United Kingdom - United States of America

www.st.com



X-ON Electronics

Largest Supplier of Electrical and Electronic Components

Click to view similar products for [Capacitive Touch Sensors](#) category:

Click to view products by [STMicroelectronics](#) manufacturer:

Other Similar products are found below :

[CP8186AT](#) [LC717A10AJ-AH](#) [CP7709DT](#) [AT42QT1012-MAH](#) [FK 8-1](#) [SMBTASK3KIT6](#) [LC717A10AR-NH](#) [MCP2036T-I/MG](#) [CP3155T](#)
[QT113BISG](#) [CAP1166-1-CZC-TR](#) [CM12-08EBP-KW1](#) [CR12CN04DPO-E2](#) [CR30SCF10ATO](#) [CR30SCF10DPO](#) [BCS M30BBI2-PSC15D-](#)
[S04K](#) [CA30CAF16PAM1](#) [VC12RN230](#) [XT130B1FBL2](#) [FDC1004DGSR](#) [FDC1004DGST](#) [CR18SCF05DPO](#) [CR30CN15DPO-E2](#)
[VC12RT23010M](#) [CDWM3020ZPM](#) [17-8421-226](#) [VC12RN924](#) [AT42QT1050-MMH](#) [AT42QT1050-MMHR](#) [AT42QT1110-AU](#)
[AT42QT1244-AU](#) [AT42QT1244-AU](#) [AT42QT1481-AUR](#) [OTBA5L](#) [OTBVR81LQD](#) [PBCL22T](#) [SM31RDLBQD](#) [AT42QT1111-MU](#)
[AT42QT1244-MU](#) [AT42QT2100-MUR](#) [AT42QT2120-MMHR](#) [VTBN6LQ](#) [MTCH6102-IMV](#) [CAP1128-1-BP-TR](#) [CA30CAF16PA](#)
[STMPE16M31QTR](#) [STMPE16M31PXQTR](#) [STM8T143-EVAL](#) [XT230A1PAL2](#) [LC717A00AR-NH](#)