

Cable-in / cable-out miniature circuit breakers and supplementary protectors



Powering Business Worldwide

Cable-in / cable-out miniature circuit breakers and supplementary protectors

Eaton offers a complete line of circuit breakers with its WMZT and QC product lines engineered for branch circuit protection and its WMZS product line designed for supplementary protection. Optimum product quality, tested reliability and safety standards for the best protection of personnel, installations and plant.

UL 489 Cable-In / Cable-Out Branch QC Circuit Breakers

Product Overview	2
QC Circuit Breakers	2
QCD Circuit Breakers	3
QCR Circuit Breakers	4
QCF Circuit Breakers	5
QCGF Circuit Breakers	6
Accessories	7

UL 489 Cable-In / Cable-Out Branch WMZ Circuit Breakers

Product Overview	9
Product Selection	10
WMZT UL 489 Circuit Breakers—10 kAIC	11
WMZH UL 489 Circuit Breakers—14 kAIC	12
Accessories	13
Technical Data	14

UL 1077 Cable-In / Cable-Out Supplementary Protectors

Product Overview	20
Product Selection	21
WMZS—B Curve (3–5X I_n Current Rating)	22
WMZS—C Curve (5–10X I_n Current Rating)	23
WMZS—D Curve (10–20X I_n Current Rating)	24
Accessories	25
Technical Data	26
Accessories	29
Technical Data	31

UL 489 Cable-In / Cable-Out Branch Circuit Breaker

QC Circuit Breakers

PRODUCT OVERVIEW

Type QC Miniature Circuit Breakers— Cable-In / Cable-Out Type QC

For Cable-In / Cable-Out Panel-Mount Applications

- Single-, two-, three- and four-pole options
- Built and listed to UL® 489
- All products UL and CSA® listed
- All products 10–100A are HACR rated



Type QC Miniature Circuit Breakers—Cable-In / Cable-Out Type QC—Catalog Numbering System

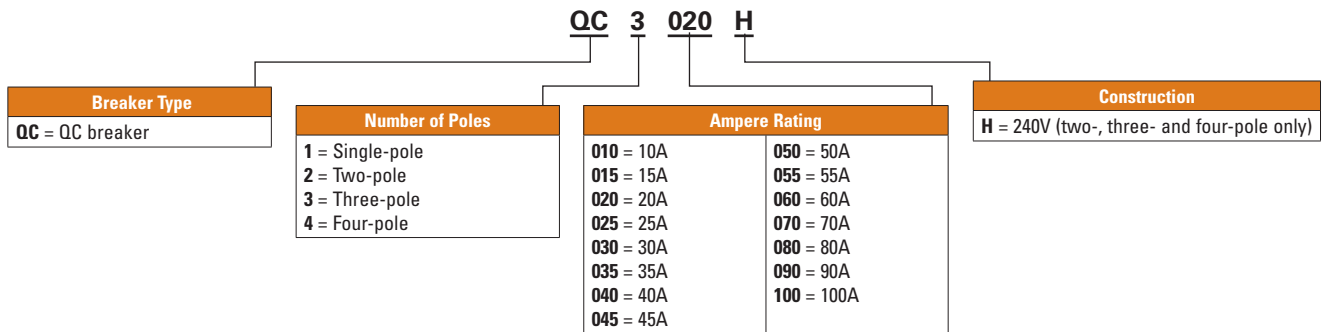

QUICKLAG® Type QC 10,000 Ampere Interrupting Capacity Thermal-Magnetic Breakers

Continuous Ampere Rating at 40°C	Single-Pole 120/240 Vac Catalog Number	Two-Pole 120/240 Vac Catalog Number	Three-Pole 240 Vac Catalog Number
10	QC1010	QC2010	—
15	QC1015 ① ②	QC2015	QC3015H
20	QC1020 ① ②	QC2020	QC3020H
30	QC1030	QC2030	QC3030H
40	QC1040	QC2040	QC3040H
50	QC1050	QC2050	QC3050H
60	—	QC2060	QC3060H
70	—	QC2070	QC3070H
100	QC1100	QC2100	QC3100H

① Switching duty rated for 120 Vac fluorescent light applications only.

② For special low-magnetic breaker, order QC1015L1 or QC1020L1.

Note: For non-automatic switches, see catalog Volume 4: Circuit Protection, CA08100005E, Tab 24.

UL 489 Cable-In / Cable-Out Branch Circuit Breaker

QCD Circuit Breakers

PRODUCT OVERVIEW

Type QC Miniature Circuit Breakers— Cable-In / Cable-Out Type QCD

For Cable-In / Cable-Out DIN Rail Mount HVAC Applications

- Single-, two- and three-pole options
- Modular construction
- DIN mounted (symmetrical rail 35 x 7.5 DIN/EN 50 022)
- Flexible power feed connection: wire size, position
- Same breaker size for entire rating range
- Field-mountable accessories: finger-shroud proof, quick-connect terminals, jumper units



Type QC Miniature Circuit Breakers—Cable-In / Cable-Out Type QCD—Catalog Numbering System

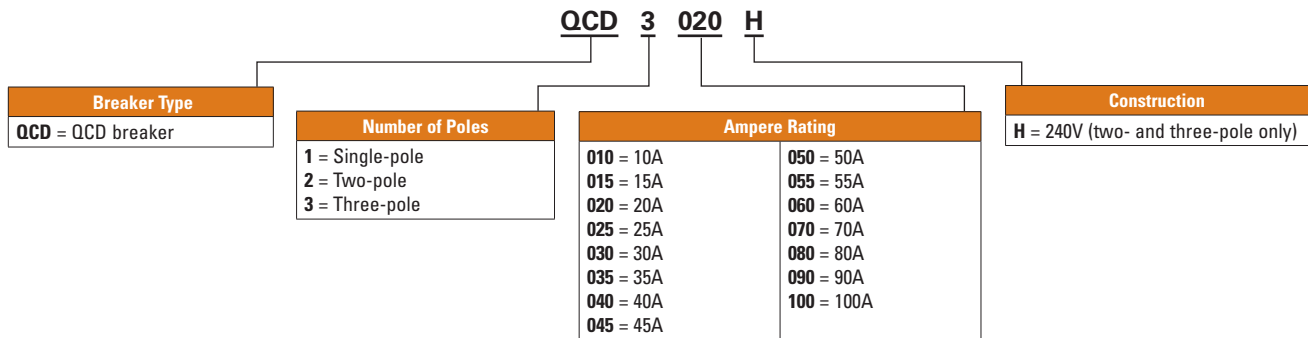

QUICKLAG Type QCD 10,000 Ampere Interrupting Capacity Thermal-Magnetic Breakers

Continuous Ampere Rating at 40°C	Single-Pole 120/240 Vac Catalog Number	Two-Pole 120/240 Vac Catalog Number	Three-Pole 240 Vac Catalog Number
10	QCD1010	QCD2010	—
15	QCD1015	QCD2015	QCD3015H
20	QCD1020	QCD2020	QCD3020H
30	QCD1030	QCD2030	QCD3030H
40	QCD1040	QCD2040	QCD3040H
50	QCD1050	QCD2050	QCD3050H
60	QCD1060	QCD2060	QCD3060H
70	—	QCD2070	QCD3070H
100	—	QCD2100	QCD3100H

UL 489 Cable-In / Cable-Out Branch Circuit Breaker

QCR Circuit Breakers

PRODUCT OVERVIEW

Type QC Miniature Circuit Breakers—Cable-In / Cable-Out 1/2-Inch Wide Types QCR, QCF

When Space is at a Premium

- QCR: For DIN rail mount cable-in/cable-out applications
- QCF: For front-mount through-the-door cable-in/cable-out applications
- 1/2-inch (12.7-mm) wide per pole
- Three-position handle: ON, Tripped (center), OFF
- Thermal-magnetic protection
- Single-, two- and three-pole
- 10 kAIC at 120/240 Vac, 10–60A
- 10 kAIC at 240 Vac, 10–30A



Type QC Miniature Circuit Breakers—Cable-In / Cable-Out 1/2-Inch Wide Types QCR, QCF—Catalog Numbering System

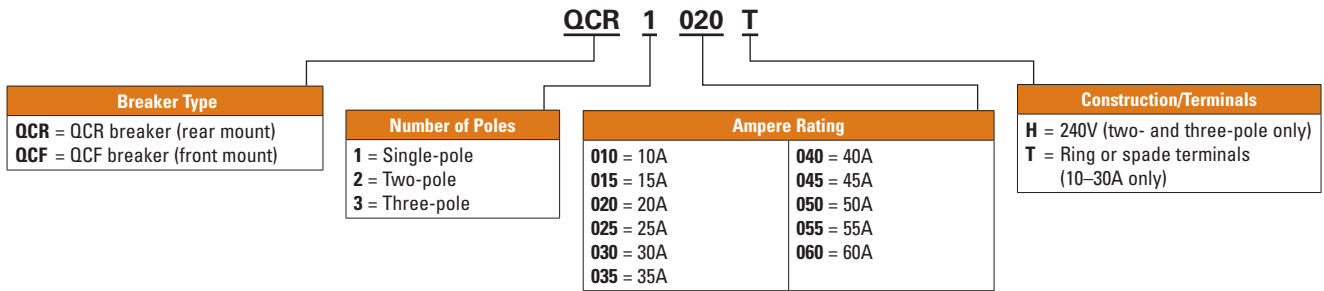

QUICKLAG Type QCR Breaker 10 kAIC Interrupting Ratings ①②③④

Continuous Ampere Rating at 40°C	Single-Pole 120/240 Vac Catalog Number	Two-Pole 120/240 Vac Catalog Number	Three-Pole 240 Vac Catalog Number
10	QCR1010 QCR1010T	QCR2010 QCR2010T	—
15	QCR1015 ⑤ QCR1015T ⑤	QCR2015 QCR2015T	QCR3015H QCR3015HT
20	QCR1020 ⑤ QCR1020T ⑤	QCR2020 QCR2020T	QCR3020H QCR3020HT
25	QCR1025 —	QCR2025 —	QCR3025H QCR3025HT
30	QCR1030 —	QCR2030 —	QCR3030H QCR3030HT
35	QCR1035	QCR2035	—
40	QCR1040	QCR2040	—
45	QCR1045	QCR2045	—
50	QCR1050	QCR2050	—
55	QCR1055	—	—
60 ⑥	QCR1060	QCR2060	—

- ① Standard breaker terminals are box type lugs.
- ② Breakers with "T" catalog number suffix are suitable for line and load side ring terminal connection (#10-32 plus/minus terminal screw provided).
- ③ Breakers with "P" catalog number suffix are suitable for terminating two 10 AWG Quick-Connect type terminals per phase on breaker load side.

- ④ Breakers with shunt trip (extra pole required on breaker right-hand side) are available on single-, two- and three-pole.
- ⑤ All 15 and 20A single-pole breakers are SWD (switching duty) rated for fluorescent lighting applications.
- ⑥ 60/75°C Cu/Al wire on all ratings except 60A, which requires Cu only conductor.

UL 489 Cable-In / Cable-Out Branch Circuit Breaker

QCF Circuit Breakers

PRODUCT OVERVIEW

Type QC Miniature Circuit Breakers—Cable-In / Cable-Out 1/2-Inch Wide, Types QCR, QCF

QUICKLAG Type QCF Breaker 10 kAIC

Interrupting Ratings ①②③

Continuous Ampere Rating at 40°C	Single-Pole 120/240 Vac Catalog Number	Two-Pole 120/240 Vac Catalog Number	Three-Pole 240 Vac Catalog Number
10	QCF1010 QCF1010T	QCF2010 QCF2010T	— —
15	QCF1015 ④ —	QCF2015 —	QCF3015H QCF3015HT
20	QCF1020 ④ —	QCF2020 —	QCF3020H QCF3020HT
25	QCF1025 —	QCF2025 —	QCF3025H QCF3025HT
30	QCF1030 —	QCF2030 —	QCF3030H QCF3030HT
40	QCF1040	QCF2040	—
50	QCF1050	QCF2050	—
60 ⑤	QCF1060	QCF2060	—

① Standard breaker terminals are box type lugs.

② Breakers with "T" catalog number suffix are suitable for line and load side ring terminal connection (#10–32 plus/minus terminal screw provided).

③ Breakers with shunt trip attachment (extra pole required on breaker right-hand side) are available.

④ All 15 and 20A single-pole breakers are SWD (switching duty) rated for fluorescent lighting applications.

⑤ 60/75°C Cu/Al wire on all ratings except 60A, which requires Cu only conductor.

Accessories

Description	Catalog Number
Steel mounting clip mounts QCR breaker if individual mounting is required. Quantity of two required for single- and two-pole, and four required for three-pole breakers.	QCRMTGFT
Removable padlock device for single-pole QCR or QCF breaker.	QCRFPL1P
Removable padlock device for multi-pole QCR or QCF breaker.	QCRFPLMP
Padlock bracket assembly for QCR or QCF single- or multi-pole breakers (OFF only).	QCRFLOFF
Padlock bracket for QCR, lock-off only.	QCRPLOFF
QUICKLAG Type C Spacer	QCRSPACER
 <p>QCR and QCF Ring or Spade Lug Terminals (10–30A ratings only) Factory-installed line and load side terminals each equipped with a #10–32 screw suitable for terminating one 10 AWG wire with insulated ring or spade type terminal as shown.</p>	Suffix "T"

UL 489 Cable-In / Cable-Out Branch Circuit Breaker

QCGF Circuit Breakers

PRODUCT OVERVIEW

Type QC Miniature Circuit Breakers—Cable-In / Cable-Out 1/2-Inch Wide Types QCGF, QCGFEP

For Cable-In / Cable-Out Panel-Mount Applications

- QUICKLAG ground fault circuit breakers, Class A GFCI:
 - Built and tested to UL 943
 - 5 mA trip sensitivity
- QUICKLAG ground fault equipment protectors:
 - Built and tested to UL 1053
 - 30 mA trip sensitivity
- All products UL and CSA listed



Type QC Miniature Circuit Breakers—Cable-In / Cable-Out Ground Fault and Equipment Protector Types QCGF, QCGFEP—Catalog Numbering System

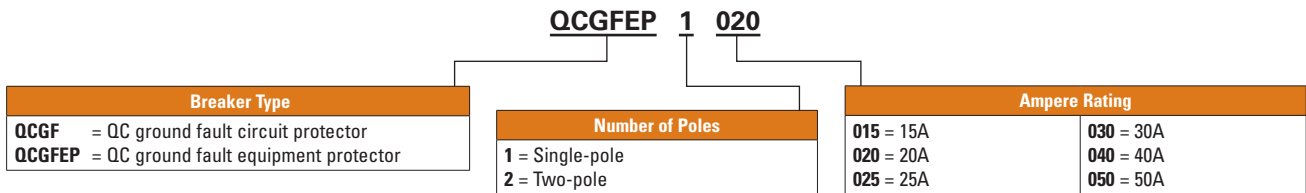

Types QCGF and QCGFEP Thermal-Magnetic Breakers

Continuous Ampere Rating at 40°C	Single-Pole 120/240 Vac Catalog Number	Two-Pole 120/240 Vac Catalog Number
Ground Fault Circuit Breakers—5 mA Sensitivity		
QUICKLAG Type: QCGF 10,000 Ampere Interrupting Capacity		
15	QCGF1015	QCGF2015
20	QCGF1020	QCGF2020
30	QCGF1030	QCGF2030
40	QCGF1040	QCGF2040
50	—	QCGF2050
Ground Fault Equipment Protectors—30 mA Sensitivity		
QUICKLAG Type: QCGFEP 10,000 Ampere Interrupting Capacity		
15	QCGFEP1015	QCGFEP2015
20	QCGFEP1020	QCGFEP2020
30	QCGFEP1030	QCGFEP2030
40	QCGFEP1040	QCGFEP2040
50	—	QCGFEP2050







UL 489 Cable-In / Cable-Out Branch Circuit Breaker

QC Circuit Breakers

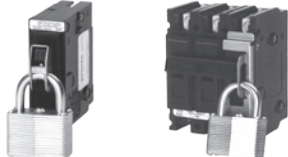
ACCESSORIES

Type QC Miniature Circuit Breakers

Accessories

	Accessory	Description	Catalog Number
 <p>QL1NPL QL23NPL</p>	Handle locks: non-padlockable ①	QUICKLAG Type P, B, C—single-pole QUICKLAG Type P, B, C—two-, three-pole	QL1NPL QL23NPL
 <p>QL1PL QC123PL</p>	Handle locks: padlockable	QUICKLAG Type P, B, C—single-pole QUICKLAG Type C—single-, two-, three-pole QUICKLAG Type C—single-, two-, three-pole (off only)	QL1PL QC123PL QCD123PLOFF
 <p>QL1HT</p>	Handle tie	QUICKLAG handle tie—single-pole QUICKLAG handle tie—three-pole	QL1HT QL3HT
 <p>QCFCLIP</p>  <p>QC1FP</p>  <p>QC2FP</p>  <p>QC3FP</p>  <p>QCBCLIP</p>	Mounting hardware	QUICKLAG Type C face mounting clip QUICKLAG Type C face mounting plate—single-pole QUICKLAG Type C face mounting plate—two-pole QUICKLAG Type C face mounting plate—three-pole QUICKLAG Type C face mounting plate and lock-off (off only)—two-pole ② QUICKLAG Type C face mounting plate and lock-off (off only)—three-pole QUICKLAG Type C base mounting clamp	QCFCLIP QC1FP QC2FP QC3FP QC2FPLOFF QC3FPLOFF QCBCLIP

① Can lock in ON or OFF position.

② Suitable for ground fault breakers.



UL 489 Cable-In / Cable-Out Branch Circuit Breaker

QC Circuit Breakers

ACCESSORIES

Type QC Miniature Circuit Breakers

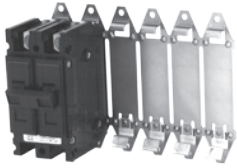
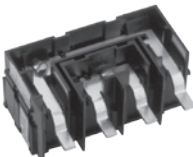
Accessories (Continued)

	Accessory ①	Description	Catalog Number
 <p>QC6BP</p>	Mounting hardware	QUICKLAG base mounting plate—six poles total	QC6BP
		QUICKLAG Type C base mounting plate—six poles total— heavy-duty screw-secured	QC6BPS
		QUICKLAG Type C (QCD) two-way jumper unit with cover	QCDJ2
		QUICKLAG Type C (QCD) four-way jumper unit with cover	QCDJ4
		QUICKLAG Type C (QCD) six-way jumper unit with cover	QCDJ6
		QUICKLAG Type C (QCD) two-way jumper unit, no cover	QCDJ2T
		QUICKLAG Type C (QCD) four-way jumper unit, no cover	QCDJ4T
		QUICKLAG Type C (QCD) six-way jumper unit, no cover	QCDJ6T
		QUICKLAG Type QCD finger protection attachment	QCDFP
		QUICKLAG Type C DIN rail adapter	QCDINADAPT
 <p>QCDJ4</p>			
 <p>QCDINADAPT</p>			
 <p>QCDFP</p>			

① See page 5 for QCR and QCF accessories.

UL 489 Cable-In / Cable-Out Branch Circuit Breaker

WMZ Circuit Breakers

PRODUCT OVERVIEW

Optimum and Efficient Protection

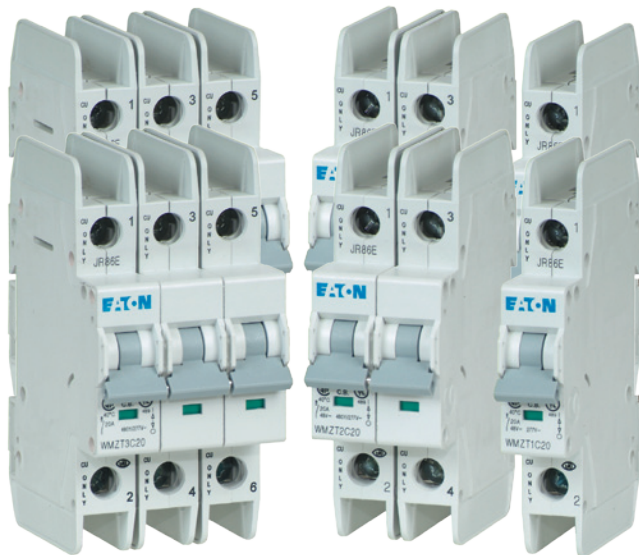

Optimum product quality, tested reliability and safety standards for best protection of personnel, installations and plant. Eaton's WMZ DIN rail mountable circuit breaker is designed for use in branch service applications.

Powerful Offering for Machine and System Builders

The WMZ is available with C and D characteristics in accordance with UL 489, CSA C22.2 No.5; UL 1077, CSA C22.2 No.235 and IEC 60947-2. These devices are CE marked.

Typical Applications

Feeder and Branch Circuit Protection

- Convenience receptacle circuits (internal/external)
- Motor control circuits
- Load circuits leaving the equipment (external)
- HACR equipment (heating, air conditioning, refrigeration) (internal/external)
- PLC I/O points
- Computers
- Power supplies
- Control instrumentation
- Relays
- UPS
- Power conditioners

Features

- Complete range of UL 489 listed DIN rail mounted miniature circuit breakers up to 40A current rating
- Standard ratings of 10 kAIC at 277/480 Vac
- Select amperages available at 14 kAIC at 277/480 Vac and 10 kAIC at 125 Vdc
- Current limiting design provides fast short-circuit interruption that reduces the let-through energy, which can damage the circuit
- Suitable for branch circuit device protection
- Thermal-magnetic overcurrent protection
 - Two levels of short-circuit protection, categorized by C and D curves
- Trip-free design—breaker can not be defeated by holding the handle in the ON position
- Captive screws cannot be lost
- SWD (switching duty)—suitable for switching fluorescent lighting loads ($I_n \leq 20A$)
- Fulfill UL 489, CSA C22.2 No.5 and also IEC 60947-2 Standard
- For use in applications for which UL 1077 or CSA C22.2 No.235 are also allowed
- Field-installable shunt trip and auxiliary switch subsequent mounting
- Separate version for ring-tongue connection (Type WMZT....T), terminal screws can be removed (on both sides)
- Module width of only 17.7 mm (per pole)
- Contact Position Indicator (red/green)
- Easy installation on DIN rail
- Possibility for sealing the toggle in ON or OFF position

WMZ Complies with the Latest National and International Standards

Standards—Feeder and Branch Circuit Protection

UL 489

Standard for molded-case circuit breakers (MCCB) for feeder and branch circuit protection.

Products meet the requirements of the National Electrical Code® (NEC®).



CSA C22.2 No.5

Standard for molded-case circuit breakers (MCCB) for feeder and branch circuit protection (corresponds closely to UL 489 Standard).

Products meet the requirements of the Canadian Electrical Code (CEC).



RoHS

These devices are RoHS compliant.



UL 489 Cable-In / Cable-Out Branch Circuit Breaker

WMZ Circuit Breakers

PRODUCT SELECTION

Tripping Curves to Choose From

Eaton WMZ branch circuit breakers are available with "C" and "D" tripping characteristics.

C-curve devices are suitable for applications where medium levels of inrush current are expected. Applications include small transformers, lighting, pilot devices, control circuits and coils. C-curve devices provide a medium magnetic trip point.

D-curve devices are suitable for applications where high levels of inrush current are expected. The high magnetic trip point prevents nuisance tripping in high inductive applications such as motors, transformers and power supplies.

Eaton WMZ devices are current limiting, which means they interrupt fault currents within one half cycle of the fault. Current limiting devices offer superior protection by reducing peak let-through current and energy.

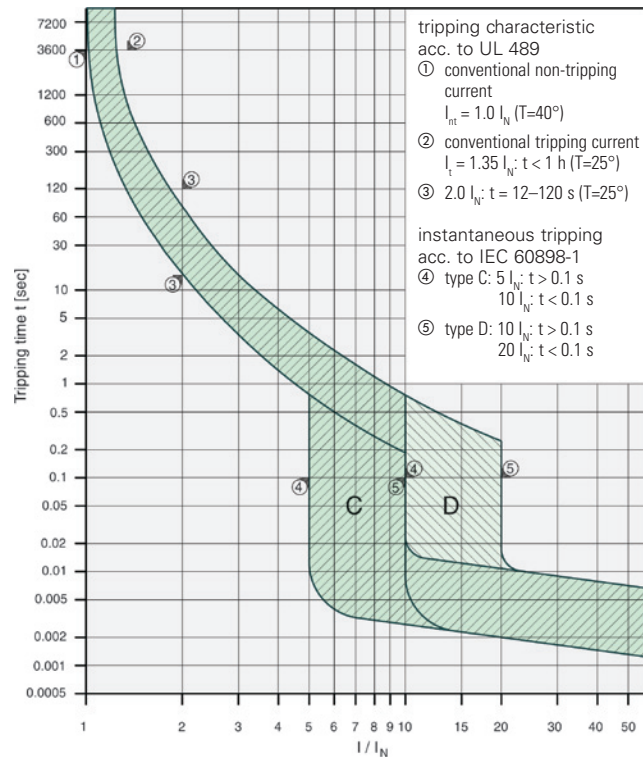

Device Printing on Front and Side

Installation options

These branch circuit breakers are available in two terminal configurations: standard box terminals that accept multiple conductors and ring-tongue terminals, ideally suited to demanding requirements of the semi-conductor industry. All breakers mount on standard 35 mm DIN rail. Bus connectors and feeder terminal facilitate mounting and wiring of multiple miniature circuit breaker arrays in control panel assemblies. These circuit breakers can also be reverse feed.

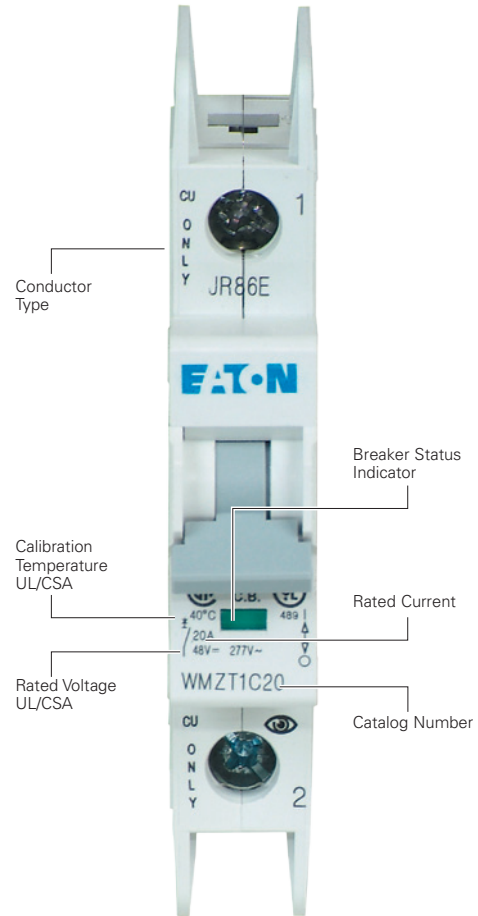

Catalog Numbering System

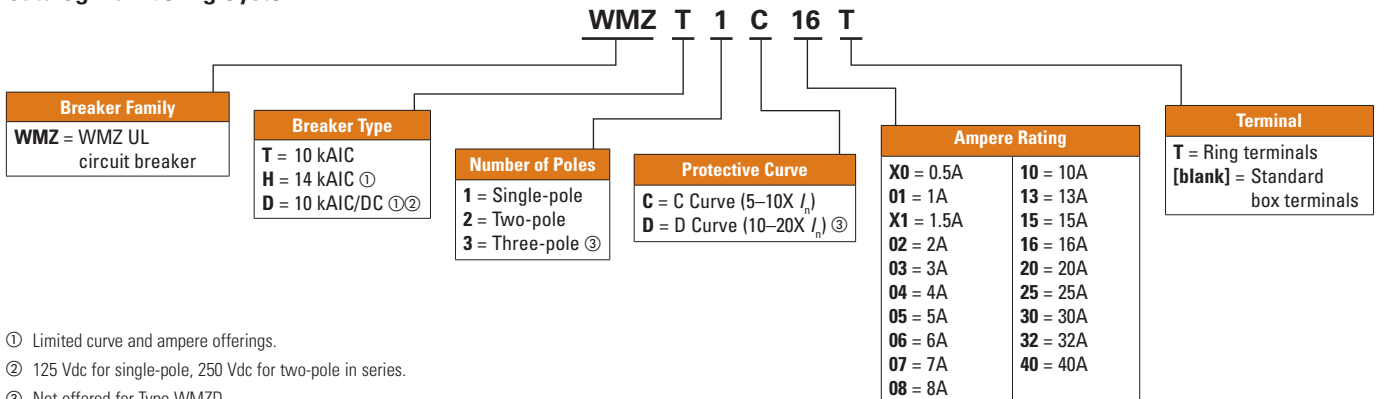

① Limited curve and ampere offerings.
 ② 125 Vdc for single-pole, 250 Vdc for two-pole in series.
 ③ Not offered for Type WMZD.

UL 489 Cable-In / Cable-Out Branch Circuit Breaker

WMZ Circuit Breakers

PRODUCT SELECTION

WMZT Product Selection

- UL approved (UL 489) and CSA Certified (CSA C22.2 No. 5-02) as branch circuit breakers
- Interrupting capacity: 10 kA UL/CSA; 15 kA IEC 60947
- Current limiting device
- Optional connections for ring-tongue terminals

WMZT UL 489 Circuit Breakers—10 kAIC



Amperes	Single-Pole Catalog Number	Two-Pole Catalog Number	Three-Pole Catalog Number
C Curve (5–10X I_n Current Rating)			
0.5	WMZT1CX0	WMZT2CX0	WMZT3CX0
1	WMZT1C01	WMZT2C01	WMZT3C01
1.5	WMZT1CX1	WMZT2CX1	WMZT3CX1
2	WMZT1C02	WMZT2C02	WMZT3C02
3	WMZT1C03	WMZT2C03	WMZT3C03
<hr/>			
4	WMZT1C04	WMZT2C00	WMZT3C04
5	WMZT1C05	WMZT2C05	WMZT3C05
6	WMZT1C06	WMZT2C06	WMZT3C06
7	WMZT1C07	WMZT2C07	WMZT3C07
8	WMZT1C08	WMZT2C08	WMZT3C08
<hr/>			
10	WMZT1C10	WMZT2C10	WMZT3C10
13	WMZT1C13	WMZT2C13	WMZT3C13
15	WMZT1C15	WMZT2C15	WMZT3C15
16	WMZT1C16	WMZT2C16	WMZT3C16
20	WMZT1C20	WMZT2C20	WMZT3C20
<hr/>			
25	WMZT1C25	WMZT2C25	WMZT3C25
30	WMZT1C30	WMZT2C30	WMZT3C30
32	WMZT1C32	WMZT2C32	WMZT3C32
40	WMZT1C40	WMZT2C40	WMZT3C40
<hr/>			
D Curve (10–20X I_n Current Rating)			
0.5	WMZT1DX0	WMZT2DX0	WMZT3DX0
1	WMZT1D01	WMZT2D01	WMZT3D01
1.5	WMZT1DX1	WMZT2DX1	WMZT3DX1
2	WMZT1D02	WMZT2D02	WMZT3D02
3	WMZT1D03	WMZT2D03	WMZT3D03
<hr/>			
4	WMZT1D04	WMZT2D04	WMZT3D04
5	WMZT1D05	WMZT2D05	WMZT3D05
6	WMZT1D06	WMZT2D06	WMZT3D06
7	WMZT1D07	WMZT2D07	WMZT3D07
8	WMZT1D08	WMZT2D08	WMZT3D08
<hr/>			
10	WMZT1D10	WMZT2D10	WMZT3D10
13	WMZT1D13	WMZT2D13	WMZT3D13
15	WMZT1D15	WMZT2D15	WMZT3D15
16	WMZT1D16	WMZT2D16	WMZT3D16
20	WMZT1D20	WMZT2D20	WMZT3D20
<hr/>			
25	WMZT1D25	WMZT2D25	WMZT3D25
30	WMZT1D30	WMZT2D30	WMZT3D30
32	WMZT1D32	WMZT2D32	WMZT3D32
40	WMZT1D40	WMZT2D40	WMZT3D40z

WMZT UL 489 Circuit Breakers with Ring-Tongue Terminals—10 kAIC



Amperes	Single-Pole Catalog Number	Two-Pole Catalog Number	Three-Pole Catalog Number
C Curve with Ring-Tongue Terminals (5–10X I_n Current Rating)			
0.5	WMZT1CX0T	WMZT2CX0T	WMZT3CX0T
1	WMZT1C01T	WMZT2C01T	WMZT3C01T
1.5	WMZT1CX1T	WMZT2CX1T	WMZT3CX1T
2	WMZT1C02T	WMZT2C02T	WMZT3C02T
3	WMZT1C03T	WMZT2C03T	WMZT3C03T
<hr/>			
4	WMZT1C04T	WMZT2C04T	WMZT3C04T
5	WMZT1C05T	WMZT2C05T	WMZT3C05T
6	WMZT1C06T	WMZT2C06T	WMZT3C06T
7	WMZT1C07T	WMZT2C07T	WMZT3C07T
8	WMZT1C08T	WMZT2C08T	WMZT3C08T
<hr/>			
10	WMZT1C10T	WMZT2C10T	WMZT3C10T
13	WMZT1C13T	WMZT2C13T	WMZT3C13T
15	WMZT1C15T	WMZT2C15T	WMZT3C15T
16	WMZT1C16T	WMZT2C16T	WMZT3C16T
20	WMZT1C20T	WMZT2C20T	WMZT3C20T
<hr/>			
25	WMZT1C25T	WMZT2C25T	WMZT3C25T
30	WMZT1C30T	WMZT2C30T	WMZT3C30T
32	WMZT1C32T	WMZT2C32T	WMZT3C32T
40	WMZT1C40T	WMZT2C40T	WMZT3C40T
<hr/>			
D Curve with Ring-Tongue Terminals (10–20X I_n Current Rating)			
0.5	WMZT1DX0T	WMZT2DX0T	WMZT3DX0T
1	WMZT1D01T	WMZT2D01T	WMZT3D01T
1.5	WMZT1DX1T	WMZT2DX1T	WMZT3DX1T
2	WMZT1D02T	WMZT2D02T	WMZT3D02T
3	WMZT1D03T	WMZT2D03T	WMZT3D03T
<hr/>			
4	WMZT1D04T	WMZT2D04T	WMZT3D04T
5	WMZT1D05T	WMZT2D05T	WMZT3D05T
6	WMZT1D06T	WMZT2D06T	WMZT3D06T
7	WMZT1D07T	WMZT2D07T	WMZT3D07T
8	WMZT1D08T	WMZT2D08T	WMZT3D08T
<hr/>			
10	WMZT1D10T	WMZT2D10T	WMZT3D10T
13	WMZT1D13T	WMZT2D13T	WMZT3D13T
15	WMZT1D15T	WMZT2D15T	WMZT3D15T
16	WMZT1D16T	WMZT2D16T	WMZT3D16T
20	WMZT1D20T	WMZT2D20T	WMZT3D20T
<hr/>			
25	WMZT1D25T	WMZT2D25T	WMZT3D25T
30	WMZT1D30T	WMZT2D30T	WMZT3D30T
32	WMZT1D32T	WMZT2D32T	WMZT3D32T
40	WMZT1D40T	WMZT2D40T	WMZT3D40T

For our complete product offering, see the Distribution Products Catalog (CA08101001E).

UL 489 Cable-In / Cable-Out Branch Circuit Breaker

WMZ Circuit Breakers

PRODUCT SELECTION

WMZH Product Selection

- UL approved (UL 489) and CSA Certified (CSA C22.2 No. 5-02) as branch circuit breakers
- Interrupting capacity: 14 kA UL/CSA; 15 kA IEC 60947
- Current limiting device
- Optional connections for ring-tongue terminals

WMZH UL 489 Circuit Breakers— 14 kAIC



Amperes	Single-Pole Catalog Number	Two-Pole Catalog Number	Three-Pole Catalog Number
C Curve (5–10X I_n Current Rating)			
15	WMZH1C15	WMZH2C15	WMZH3C15
16	WMZH1C16	WMZH2C16	WMZH3C16
20	WMZH1C20	WMZH2C20	WMZH3C20
25	WMZH1C25	WMZH2C25	WMZH3C25
D Curve (10–20X I_n Current Rating)			
13	WMZH1D13	WMZH2D13	WMZH3D13
15	WMZH1D15	WMZH2D15	WMZH3D15
16	WMZH1D16	WMZH2D16	WMZH3D16
20	WMZH1D20	WMZH2D20	WMZH3D20

WMZH UL 489 Circuit Breakers with Ring-Tongue Terminals



Amperes	Single-Pole Catalog Number	Two-Pole Catalog Number	Three-Pole Catalog Number
C Curve (5–10X I_n Current Rating)			
15	WMZH1C15T	WMZH2C15T	WMZH3C15T
16	WMZH1C16T	WMZH2C16T	WMZH3C16T
20	WMZH1C20T	WMZH2C20T	WMZH3C20T
25	WMZH1C25T	WMZH2C25T	WMZH3C25T
D Curve (10–20X I_n Current Rating)			
13	WMZH1D13T	WMZH2D13T	WMZH3D13T
15	WMZH1D15T	WMZH2D15T	WMZH3D15T
16	WMZH1D16T	WMZH2D16T	WMZH3D16T
20	WMZH1D20T	WMZH2D20T	WMZH3D20T

WMZD Product Selection

- UL approved (UL 489) and CSA Certified (CSA C22.2 No. 5-02) as branch circuit breakers
- Interrupting capacity: 10 kA at 125 Vdc UL/CSA
- 125 Vdc for single-pole, 250 Vdc for two-pole in series
- Current limiting device

WMZD UL 489 Circuit Breakers— 10 kAIC at 125 Vdc per pole



Amperes	Single-Pole Catalog Number	Two-Pole Catalog Number
C Curve (5–10X I_n Current Rating)		
2	WMZD1C02	WMZD2C02
3	WMZD1C03	WMZD2C03
4	WMZD1C04	WMZD2C04
5	WMZD1C05	WMZD2C05
6	WMZD1C06	WMZD2C06
7	WMZD1C07	WMZD2C07
8	WMZD1C08	WMZD2C08
10	WMZD1C10	WMZD2C10
13	WMZD1C13	WMZD2C13
15	WMZD1C15	WMZD2C15
16	WMZD1C16	WMZD2C16
20	WMZD1C20	WMZD2C20
25	WMZD1C25	WMZD2C25
30	WMZD1C30	WMZD2C30
32	WMZD1C32	WMZD2C32
40	WMZD1C40	WMZD2C40

UL 489 Cable-In / Cable-Out Branch Circuit Breaker

WMZ Circuit Breakers
PRODUCT SELECTION

WMZ UL 489 Breakers

Accessory/Description	Catalog Number
Two-pole contact or auxiliary contact/ Trip indicating contact	WMZSAUXTRIP
Auxiliary contact	WMZTAUX
Shunt trip 110–415 Vac	WMZTST415
Shunt trip 12–110 Vac	WMZTST110
Padlock hasp	WMZPLK
Busbar—single-pole 6 terminals	WMZT1P6T
Busbar—single-pole 12 terminals	WMZT1P12T
Busbar—single-pole 18 terminals	WMZT1P18T
Busbar—two-pole 6 terminals	WMZT2P6T
Busbar—two-pole 12 terminals	WMZT2P12T
Busbar—two-pole 18 terminals	WMZT2P18T
Busbar—three-pole 6 terminals	WMZT3P6T
Busbar—three-pole 12 terminals	WMZT3P12T
Busbar—three-pole 18 terminals	WMZT3P18T
Three-pole busbar shroud	WMZT3PSHROUD
Extension terminal—35 mm (2–14 AWG)	WMZT35EXT
Bus connector—conductors up to 50 mm ² (~1/0 AWG)	WMZTBCON ①

① Contact sales office for availability.

Tripping Signal Switch WMZSAUXTRIP, WMZTAUX

- Design according to IEC/EN 60947-5-1, IEC/EN 62019
- Field installable
- The specified minimum voltages are per contact—take into account particularly in case of series connection
- Self-cleaning contacts
- Contact material and design particularly suitable for extra low voltage
- WMZSAUXTRIP: the function of one of the two change-over contacts can be switched from “auxiliary switch” to “tripping signal switch”
- Tripping signal contact transmits message of electric tripping, not mechanical switch-off
- Test key for contact function “electrical tripping”
- WMZTAUX: will allow for > 480Y/277 Vac rating

Connection Diagram

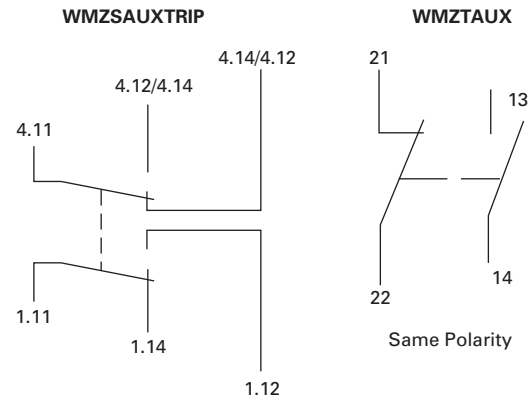

Dimensions

Miniature Circuit Breakers

WMZ

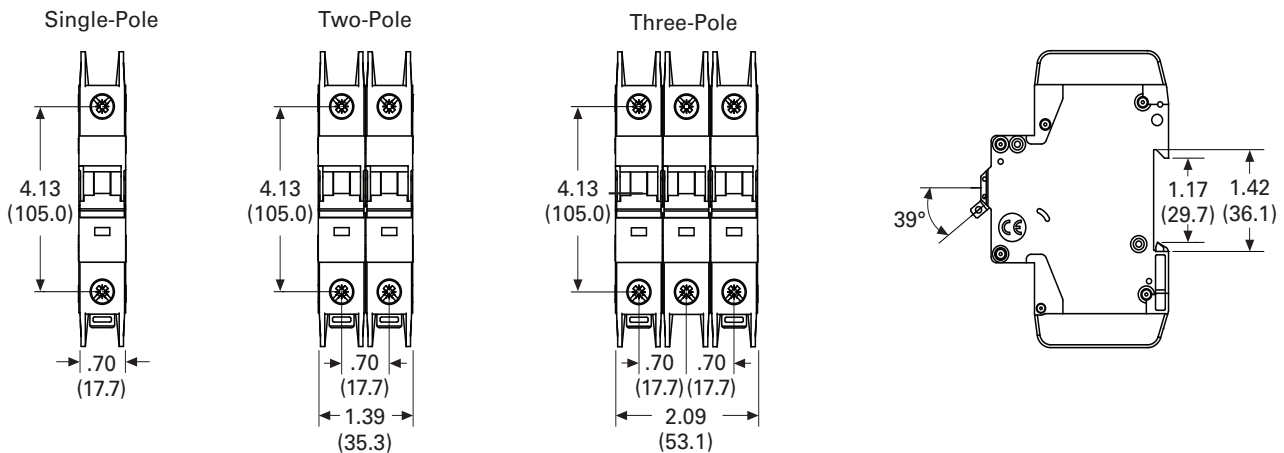

UL 489 Cable-In / Cable-Out Branch Circuit Breaker

WMZ Circuit Breakers

TECHNICAL DATA

Miniature Circuit Breakers WMZ

Connection Diagrams

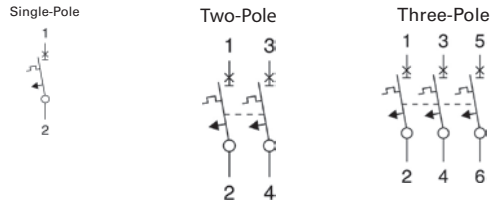

Dimensions (mm)

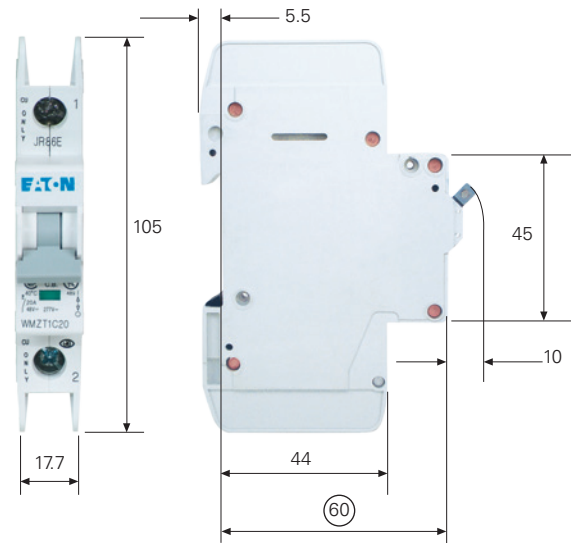

Miniature Circuit Breakers WMZ

Description	Specification
Electrical	
Design according to	UL 489, CSA C22.2 No.5, IEC 60947-2
Rated voltage WMZT	
UL/CSA	10 kAIC at 277/480V from 0.5A to 32A
UL/CSA	10 kAIC at 240 Vac for 40A
UL/CSA	10 kAIC at 48 Vdc per pole
IEC 947-2	15 kAIC at 240/415 Vac
Rated voltage WMZD	
UL/CSA	10 kAIC at 125 Vdc per pole (two poles maximum)
	10 kAIC at 250 Vdc with two poles connected in series
Rated voltage WMZH	
UL/CSA	14 kAIC at 277/480V at listed amperages
IEC 947-2	15 kAIC at 240/415 Vac
Rated frequency	50/60 Hz
Rated breaking capacity WMZT	
UL/CSA	10 kA
IEC 947-2	15 kA
Rated breaking capacity WMZH	
UL/CSA	14 kA
IEC 947-2	15 kA
Characteristic	C, D
Endurance	≥ 20,000 operations
Line voltage connection	Suitable for reverse feed
Mechanical	
Frame size	45 mm
Device height	105 mm
Device width	17.7 mm per pole
Mounting	Quick fastening with two lock-in positions on IEC/EN 60715
Upper and lower terminals	Open mouth/lift terminals
Terminal capacity	Single-wire AWG 18–6 Two-wire AWG 18–10
Terminal fastening torque	AWG 18-21: 21 lb-in AWG 10-8: 25 lb-in AWG 6: 36 lb-in
Mounting	Independent of position
Calibration temperature	
UL 489, CSA C22.2 No.5	40°C
IEC 60947-2	30°C

Power Loss at I_n

I_n [A]	Characteristic C			Characteristic D		
	Single-Pole P [W]	Two-Pole P [W]	Three-Pole P [W]	Single-Pole P [W]	Two-Pole P [W]	Three-Pole P [W]
0.5	1.6	3.2	4.7	1.6	3.2	4.8
1	1.1	2.2	3.4	0.8	1.5	2.3
1.5	1.3	2.6	3.9	1.0	2.1	3.1
2	1.4	2.8	4.3	1.0	2.1	3.1
3	1.2	2.4	3.6	1.2	2.4	3.6
4	1.4	2.9	4.3	1.4	2.9	4.3
5	1.9	3.7	5.6	1.5	2.9	4.4
6	1.2	2.3	3.5	1.2	2.3	3.5
7	1.4	2.8	4.3	1.4	2.8	4.3
8	1.4	2.8	4.2	1.2	2.4	3.7
10	1.8	3.6	5.3	1.5	3.0	4.5
13	2.4	4.7	7.1	2.0	4.1	6.1
15	1.9	3.8	5.6	1.5	3.1	4.6
16	2.1	4.3	6.4	1.7	3.5	5.2
20	2.9	5.8	8.7	1.8	3.7	5.5
25	3.1	6.2	9.3	2.6	5.1	7.7
30	3.0	6.0	9.0	2.7	5.4	8.1
32	3.4	6.8	10.2	3.1	6.2	9.3
35	3.7	7.4	11.0	3.8	7.6	11.3
40	4.0	8.1	12.1	3.9	7.8	11.6

UL 489 Cable-In / Cable-Out Branch Circuit Breaker

WMZ Circuit Breakers

TECHNICAL DATA

Let-Through Energy

Characteristic C (0.5–32A), 277V

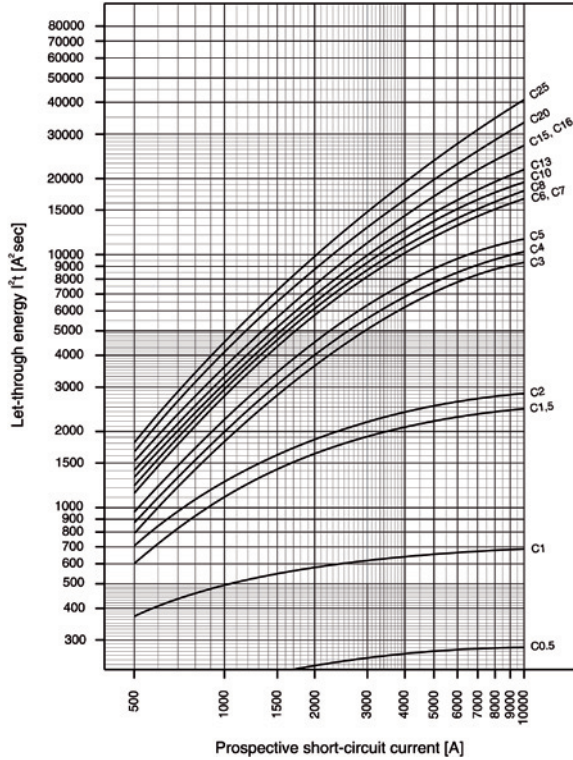

Characteristic C (40A), 240V

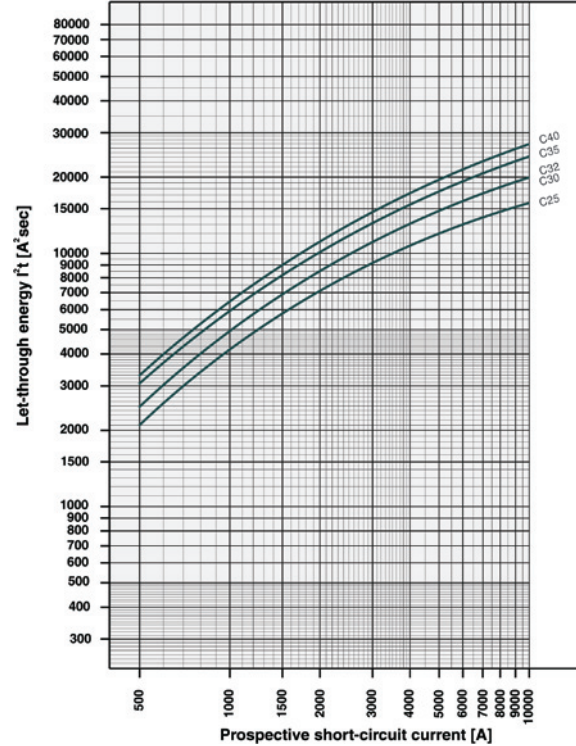

Characteristic D (0.5–32A), 277V

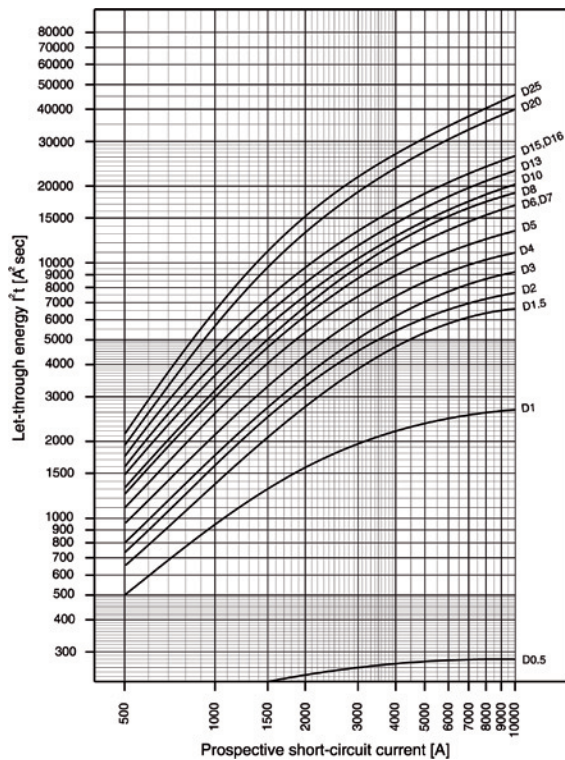

Characteristic D (40A), 240V

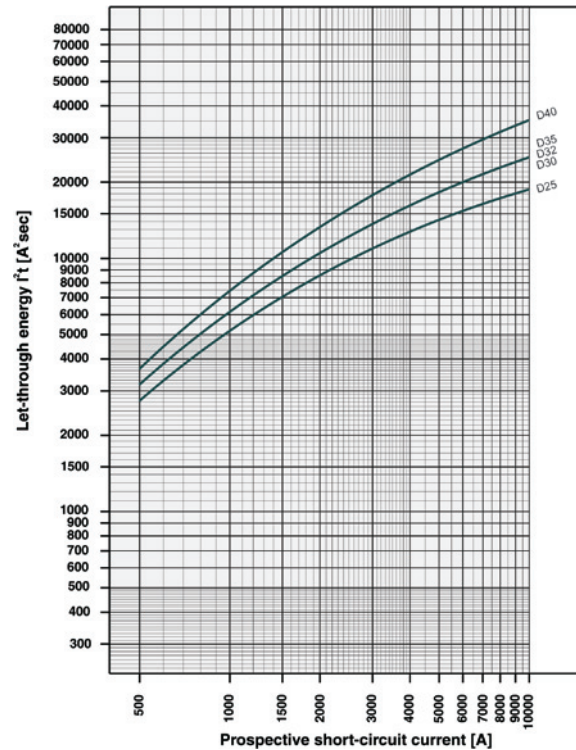

UL 489 Cable-In / Cable-Out Branch Circuit Breaker

WMZ Circuit Breakers

ACCESSORIES

Dimensions (mm)

WMZT__6T

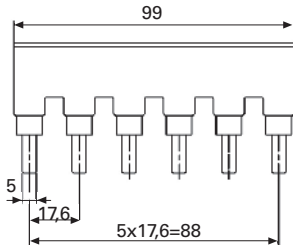

WMZT__12T

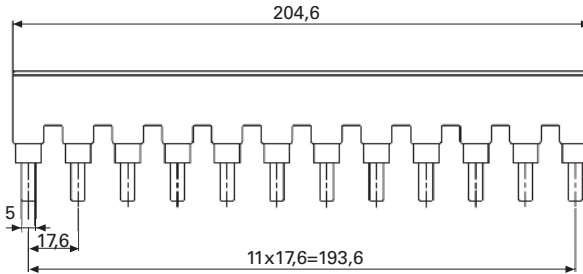

WMZT3PSHROUD

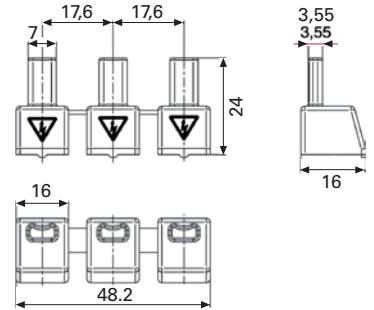

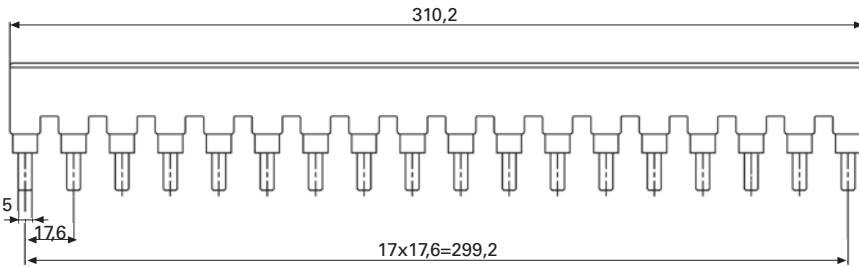

WMZT__18T

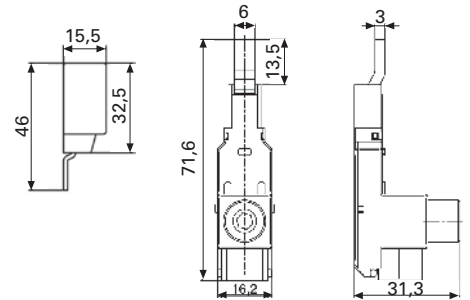

WMZT35EXT



WMZT35EXT

Description	UL 489	IEC/EN 60947-2
	# 2-14 AWG 60/75°C Cu	2.5-35 mm ² 60/75°C Cu
	0.56 in	14 mm
Tested according to 		Tightening torque of terminal screws
UL 486A	# 14 AWG	≥ 2.3 Nm
UL 486B	# 8-12 AWG	≥ 2.8 Nm
UL 486E	# 6-1 AWG	4 Nm

Lockout Attachment

WMZPLK

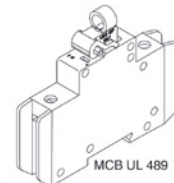
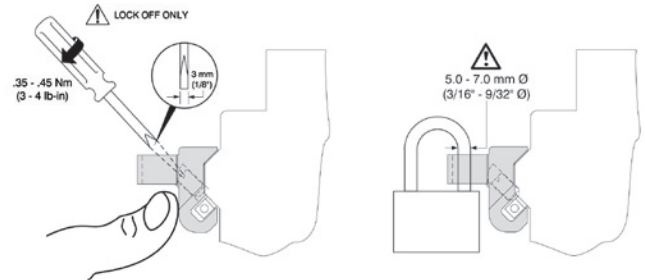

UL 489 Cable-In / Cable-Out Branch Circuit Breaker

WMZ Circuit Breakers

TECHNICAL DATA

Influence of Ambient Temperature T on Load Carrying Capacity

Device Market Current Rating I_n (A) at 40°C	I_n (A) at Higher Ambient Temperature							
	15°C	20°C	25°C	30°C	40°C	50°C	55°C	60°C
0.5	0.6	0.5	0.5	0.5	0.5	0.5	0.5	0.5
1.0	1.1	1.1	1.1	1.0	1.0	1.0	0.9	0.9
1.5	1.7	1.6	1.6	1.6	1.5	1.4	1.4	1.4
2.0	2.2	2.2	2.1	2.1	2.0	1.9	1.9	1.8
3.0	3.3	3.2	3.2	3.1	3.0	2.9	2.9	2.8
4.0	4.4	4.3	4.2	4.2	4.0	3.8	3.8	3.7
5.0	5.5	5.4	5.3	5.2	5.0	4.8	4.7	4.6
6.0	6.6	6.5	6.4	6.2	6.0	5.8	5.6	5.5
7.0	7.7	7.6	7.4	7.3	7.0	6.7	6.6	6.4
8.0	8.8	8.6	8.5	8.3	8.0	7.7	7.5	7.4
10.0	11.0	10.8	10.6	10.4	10.0	9.6	9.4	9.2
13.0	14.3	14.0	13.8	13.5	13.0	12.5	12.5	12.0
15.0	16.5	16.2	15.9	15.6	15.0	14.4	14.1	13.8
16.0	17.6	17.3	17.0	16.6	16.0	15.4	15.0	14.7
20.0	22.0	21.6	21.2	20.8	20.0	19.2	18.8	18.4
25.0	27.5	27.0	26.5	26.0	25.0	24.0	23.3	23.0
30.0	33.0	32.4	31.8	31.2	30.0	28.8	28.2	27.6
32.0	35.2	34.6	33.9	33.3	32.0	30.7	30.1	29.4
40.0	44.0	43.2	42.4	41.6	40.0	38.4	37.6	36.8

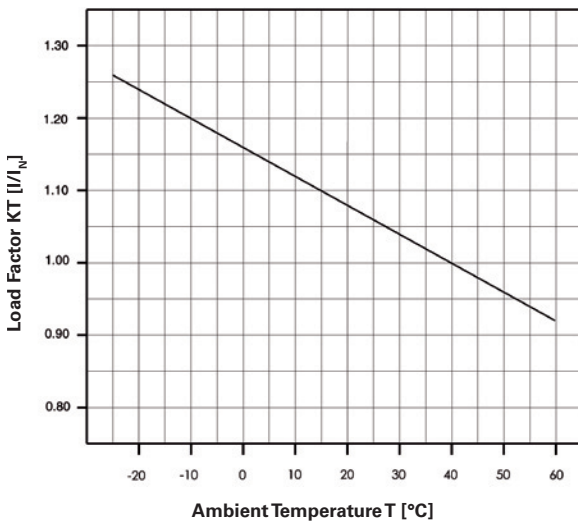

Maximum Load I_L at ambient temperature T: $I_L(T) = I_n K_T(T)$

UL 489 Cable-In / Cable-Out Branch Circuit Breaker

WMZ Circuit Breakers

ACCESSORIES

Accessories

Description	WMZSAUXTRIP	WMZTAUX
Electrical		
Contact function	2C0	1N0 + 1NC
Rated voltage	230V	250V
Frequency	50/60 Hz	50/60 Hz
Rated current	2A	6A
Rated thermal current I_{th}	2A	6A
Utilization category AC13 rated operational current I_o	3A/250 Vac	3A/250 Vac
Utilization category AC15 rated operational current I_o	2A/250 Vac	2A/250 Vac
Utilization category DC12 rated operational current I_o	0.5A/110 Vdc	0.5A/110 Vdc 0.25A/220 Vdc
Rated insulation voltage U_i	250 Vac	250 Vac
Minimum operational voltage per contact U_{min}	5 Vdc	5 Vdc
Minimum operational current I_{min}	10 mA DC	10 mA AC/DC
Rated peak withstand voltage U_{imp} (1.2/50 μ)	2.5 kV	4 kV
Conditional short-circuit current I_k with backup fuse 6A	1 kA	1 kA
Max. backup fuse, overload and short circuit	6A gL	—
Mechanical		
Tripping indicator "electrical tripping"	Blue/white	—
Frame size	45 mm	45 mm
Device height	80 mm	80 mm
Device width	8.8 mm (0.5MU)	8.8 mm (0.5MU)
Mounting	Onto switching device	—
Degree of protection, built-in	IP40	IP40
Terminal protection	Finger and hand touch safe according to BGV A3, ÖVE-EN 6	Finger and hand touch safe according to BGV A3, ÖVE-EN 6
Terminals	Lift terminals	Lift terminals
Terminal capacity	20–14 AWG	0.5–2.5 mm ²
Terminal screws	M3 (posidrive Z0)	M3 (posidrive Z0)
Fastening torque of terminal screws	7 lb-in	Max. 1.2 Nm

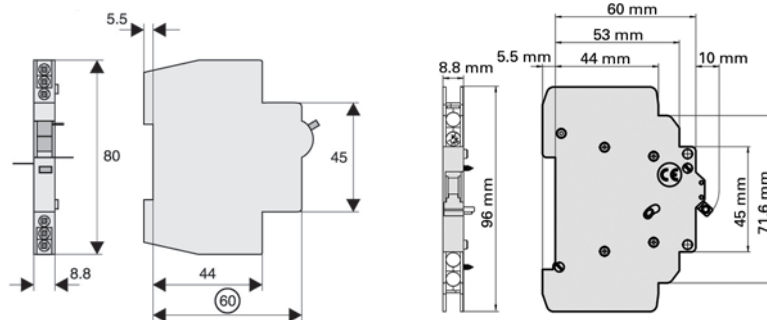

UL 489 Cable-In / Cable-Out Branch Circuit Breaker

WMZ Circuit Breakers

ACCESSORIES

Shunt Trip Release WMZTST

- Remote release for subsequent mounting onto WMZT
- Additional installation of standard auxiliary switch is possible
- Position indicator red–green

Connection Diagram

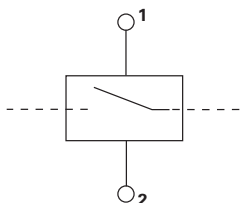

Shunt Trip Release WMZTST

Description	WMZTST110	WMZTST415
Electrical		
Can be mounted onto	WMZT/WMZH/WMZD	WMZT/WMZH/WMZD
Operational voltage range	12–110 Vac 12–60 Vdc	110–415 Vac 110–230 Vdc
Frequency	50/60 Hz	50/60 Hz
Mechanical		
Frame size	45 mm	45 mm
Device height	105 mm	105 mm
Device width	17.5 mm	17.5 mm
Mounting	Quick fastening with 2 lock-in positions on EN 50022	
Degree of protection, built-in	IP40	IP40
Terminal protection	Finger and hand touch safe according to BGV A3, ÖVE-EN 6	
Terminals	Open mouthed/lift	Open mouthed/lift
Terminal capacity single- and two-wire	18–10 AWG	18–10 AWG

Busbar Block UL 489 (Pin)

- Tested according to UL 489
- Do not cut
- Extension terminal 35 mm² WMZT35EXT for copper conductors
- To cover pins not being used, use busbar tag shrouds WMZT3PSHROUD

Connection Diagram

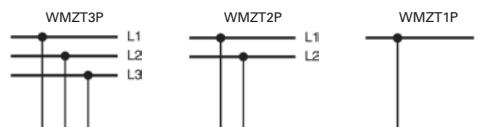

Busbar Block UL 489 (Pin)

Description	UL 489	IEC/EN 60947-2
Electrical		
Rated operational voltage	480/277 Vac 96 Vdc	—
Rated frequency	50/60 Hz	—
Rated voltage	—	690 Vac
Overvoltage category	—	III
Rated impulse withstand voltage U _{imp}	—	9.5 kV
Rated current	80A	80A
Rated conditional short-circuit current AC with 350A gG	—	15 kA
Short-circuit current	10 kA	—
Mechanical		
Busbar cross section	—	16 mm ² Cu
Flame class according to UL 94	V0	—
Pollution degree	—	2
Comparative tracking index	—	CTI 600
Minimum clearance (internal/external)	—	> 9.5/25.4 mm
Minimum creepage distance (internal/external)	—	> 12.7/50.8 mm
Resistance to climatic conditions	—	According to DIN/EN60068

UL 1077 Cable-In / Cable-Out Supplementary Protectors

WMZS Circuit Breakers

PRODUCT OVERVIEW

Optimum and Efficient Protection



Optimum product quality, tested reliability and safety standards for best protection of personnel, installations and plant. Eaton's WMZS DIN rail mountable circuit breaker is designed for use in control panel applications.

Powerful Offering for Machine and System Builders

The WMZS is available with B, C and D characteristics in accordance with UL 1077, CSA C22.2 No.235 and IEC 60947-2. These devices are CE marked.

Typical Applications

Supplementary protection

- Control circuits
- Lighting
- Business equipment
- Appliances

Features

- Complete range of UL 1077 recognized DIN rail mounted miniature circuit breakers up to 63A current rating
- Standard ratings of 10 kAIC at 277/480 Vac
- Current limiting design provides fast short-circuit interruption that reduces the let-through energy, which can damage the circuit
- Suitable for supplementary protection
- Thermal-magnetic overcurrent protection
 - Three levels of short-circuit protection, categorized by B, C and D curves
- Trip-free design—breaker can not be defeated by holding the handle in the ON position
- Captive screws cannot be lost
- Fulfill UL 1077, CSA C22.2 No.235 and also IEC 60947-2 standard
- Field-installable shunt trip and auxiliary switch subsequent mounting
- Module width of only 17.5 mm (per pole)
- Contact Position Indicator (red/green)
- Easy installation on DIN rail
- Possibility for sealing the toggle in ON or OFF position

WMZS Complies with the Latest National and International Standards

Standards—Supplementary Protection

UL 1077, CSA C22.2 No. 235

Apply to supplementary protectors intended for use as overcurrent, or overvoltage or undervoltage protection within an appliance or other electrical equipment where branch circuit protection is already provided, or is not required.



RoHS

These devices are RoHS compliant.



UL 1077 Cable-In / Cable-Out Supplementary Protectors

WMZS Circuit Breakers

PRODUCT SELECTION

Discover These Advanced Features

Breakers install on standard DIN rail

Available in single-, two- and three-pole models

Color-coded indicator provides breaker status for easy troubleshooting

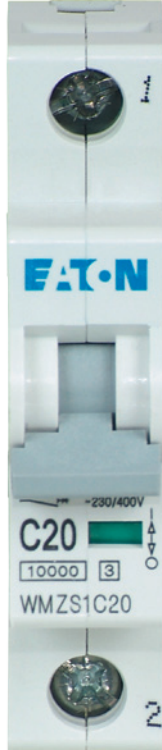

Captive posidrive terminal screws with finger and back-of-hand protection (IP20)

Trip-free design; breaker cannot be defeated by holding the handle in the ON position

Breaker information printed on the front of the device for quick identification

Three Tripping Curves to Choose From

Eaton WMZS Supplementary Protectors are available with three different tripping characteristics, including Type B, C and D. Definitions for each trip curve are contained on the ordering pages and can be used to determine the optimal characteristic for your application. For example, low level short-circuit faults in control wiring, such as PLCs, are best protected by devices with Type B trip characteristics (3 to 5X continuous rating of the device (I_n)).

Even though not required by NEC or CEC for Supplementary Protectors, Eaton's WMZS devices are current limiting, which means that they interrupt fault currents within one half cycle. Current limiting devices offer superior protection by reducing peak let-through current and energy.

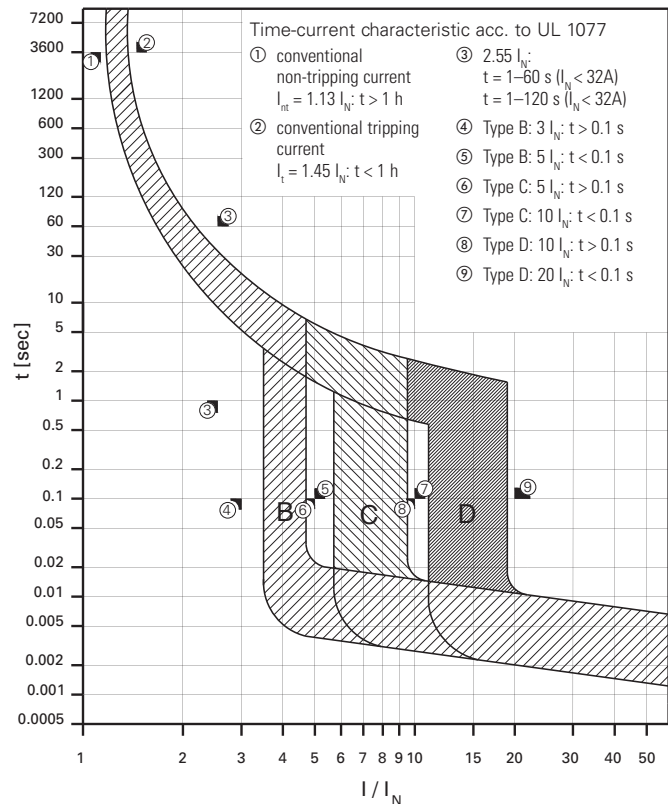

Catalog Numbering System

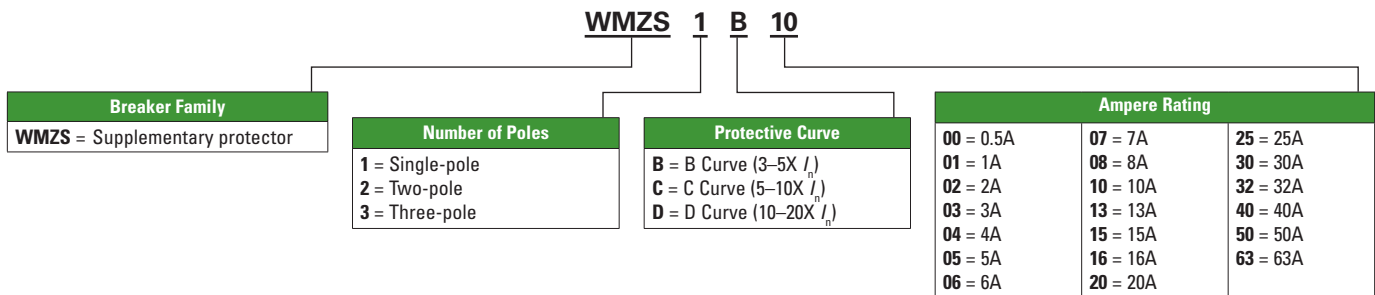

UL 1077 Cable-In / Cable-Out Supplementary Protectors

WMZS Circuit Breakers

PRODUCT SELECTION

WMZS Product Selection—

B Curve (3–5X I_n Current Rating)

- Designed for resistive or slightly inductive loads
- Response time of instantaneous trip: 3–5X I_n current rating
- UL Recognized and CSA Certified as Supplementary Protectors
- For international and domestic use (conform to IEC 60947-2)

Suitable for applications where protection against low-level short-circuit faults in control wiring is desired. Instantaneous trip is 3–5X continuous rating of device (I_n). Applications include PLC wiring, business equipment, lighting, appliances and some motors. Low magnetic trip point.

B Curve (3–5X I_n Current Rating)— Designed for Resistive or Slightly Inductive Loads ①



Amperes	Single-Pole Catalog Number	Two-Pole Catalog Number	Three-Pole Catalog Number
6	WMZS1B06	WMZS2B06	WMZS3B06
7	WMZS1B07	WMZS2B07	WMZS3B07
8	WMZS1B08	WMZS2B08	WMZS3B08
10	WMZS1B10	WMZS2B10	WMZS3B10
13	WMZS1B13	WMZS2B13	WMZS3B13
15	WMZS1B15	WMZS2B15	WMZS3B15
16	WMZS1B16	WMZS2B16	WMZS3B16
20	WMZS1B20	WMZS2B20	WMZS3B20
25	WMZS1B25	WMZS2B25	WMZS3B25
30	WMZS1B30	WMZS2B30	WMZS3B30
32	WMZS1B32	WMZS2B32	WMZS3B32
40	WMZS1B40	WMZS2B40	WMZS3B40
50	WMZS1B50	WMZS2B50	WMZS3B50
63	WMZS1B63	WMZS2B63	WMZS3B63

① In North America, these switches are UL Recognized and CSA Certified as Supplementary Protection devices. Per the intent of NEC (National Electrical Code), Article 240, and CEC (Canadian Electrical Code), Part 1 C22.1, supplementary breakers cannot be used as a substitute for the branch circuit protective device. They can be used to provide overcurrent protection within an appliance or other electrical equipment where branch circuit overcurrent protection is already provided, or is not required.

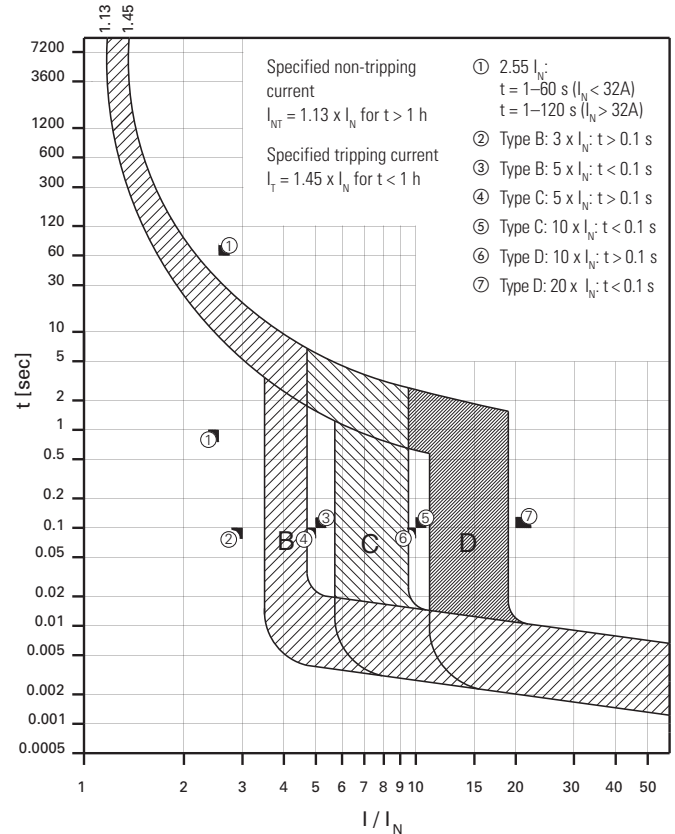

UL 1077 Cable-In / Cable-Out Supplementary Protectors

WMZS Circuit Breakers

PRODUCT SELECTION

WMZS Product Selection— C Curve (5–10X I_n Current Rating)

- Designed for inductive loads
- Response time of instantaneous trip: 5–10X I_n current rating
- UL Recognized and CSA Certified as Supplementary Protectors
- For international and domestic use (conform to IEC 60947-2)

Suitable for applications where medium levels of inrush current are expected. Instantaneous trip is 5–10X rating of device (I_n). Applications include small transformers, lighting, pilot devices, control circuits and coils. Medium magnetic trip point.

C Curve (5–10X I_n Current Rating)— Designed for Inductive Loads ①



Amperes	Single-Pole Catalog Number	Two-Pole Catalog Number	Three-Pole Catalog Number
0.5	WMZS1C00	WMZS2C00	WMZS3C00
1	WMZS1C01	WMZS2C01	WMZS3C01
2	WMZS1C02	WMZS2C02	WMZS3C02
3	WMZS1C03	WMZS2C03	WMZS3C03
4	WMZS1C04	WMZS2C04	WMZS3C04
5	WMZS1C05	WMZS2C05	WMZS3C05
6	WMZS1C06	WMZS2C06	WMZS3C06
7	WMZS1C07	WMZS2C07	WMZS3C07
8	WMZS1C08	WMZS2C08	WMZS3C08
10	WMZS1C10	WMZS2C10	WMZS3C10
13	WMZS1C13	WMZS2C13	WMZS3C13
15	WMZS1C15	WMZS2C15	WMZS3C15
16	WMZS1C16	WMZS2C16	WMZS3C16
20	WMZS1C20	WMZS2C20	WMZS3C20
25	WMZS1C25	WMZS2C25	WMZS3C25
30	WMZS1C30	WMZS2C30	WMZS3C30
32	WMZS1C32	WMZS2C32	WMZS3C32
40	WMZS1C40	WMZS2C40	WMZS3C40
50	WMZS1C50	WMZS2C50	WMZS3C50
63	WMZS1C63	WMZS2C63	WMZS3C63

① In North America, these switches are UL Recognized and CSA Certified as Supplementary Protection devices. Per the intent of NEC (National Electrical Code), Article 240, and CEC (Canadian Electrical Code), Part 1 C22.1, supplementary breakers cannot be used as a substitute for the branch circuit protective device. They can be used to provide overcurrent protection within an appliance or other electrical equipment where branch circuit overcurrent protection is already provided, or is not required.

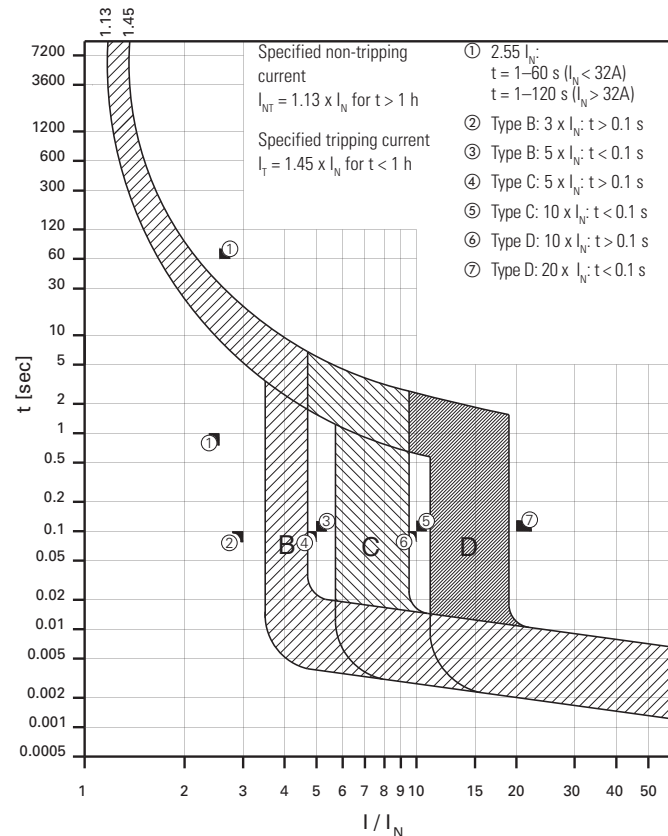

For our complete product offering, see the Distribution Products Catalog (CA08101001E).

UL 1077 Cable-In / Cable-Out Supplementary Protectors

WMZS Circuit Breakers

PRODUCT SELECTION

WMZS Product Selection—

D Curve (10–20X I_n Current Rating)

- Designed for highly inductive loads
- Response time of instantaneous trip: 10–20X I_n current rating
- UL Recognized and CSA Certified as Supplementary Protectors
- For international and domestic use (conform to IEC 60947-2)

Suitable for applications where high levels of inrush current are expected. Instantaneous trip is 10–20X rating of device (I_n). The high magnetic trip point prevents nuisance tripping in high inductive applications such as motors, transformers and power supplies.

D Curve (10–20X I_n Current Rating) — Designed for Inductive Loads ①



Amperes	Single-Pole Catalog Number	Two-Pole Catalog Number	Three-Pole Catalog Number
0.5	WMZS1D00	WMZS2D00	WMZS3D00
1	WMZS1D01	WMZS2D01	WMZS3D01
2	WMZS1D02	WMZS2D02	WMZS3D02
3	WMZS1D03	WMZS2D03	WMZS3D03
4	WMZS1D04	WMZS2D04	WMZS3D04
5	WMZS1D05	WMZS2D05	WMZS3D05
6	WMZS1D06	WMZS2D06	WMZS3D06
7	WMZS1D07	WMZS2D07	WMZS3D07
8	WMZS1D08	WMZS2D08	WMZS3D08
10	WMZS1D10	WMZS2D10	WMZS3D10
13	WMZS1D13	WMZS2D13	WMZS3D13
15	WMZS1D15	WMZS2D15	WMZS3D15
16	WMZS1D16	WMZS2D16	WMZS3D16
20	WMZS1D20	WMZS2D20	WMZS3D20
25	WMZS1D25	WMZS2D25	WMZS3D25
30	WMZS1D30	WMZS2D30	WMZS3D30
32	WMZS1D32	WMZS2D32	WMZS3D32
40	WMZS1D40	WMZS2D40	WMZS3D40

① In North America, these switches are UL recognized and CSA Certified as Supplementary Protection devices. Per the intent of NEC (National Electrical Code), Article 240, and CEC (Canadian Electrical Code), Part 1 C22.1, supplementary breakers cannot be used as a substitute for the branch circuit protective device. They can be used to provide overcurrent protection within an appliance or other electrical equipment where branch circuit overcurrent protection is already provided, or is not required.

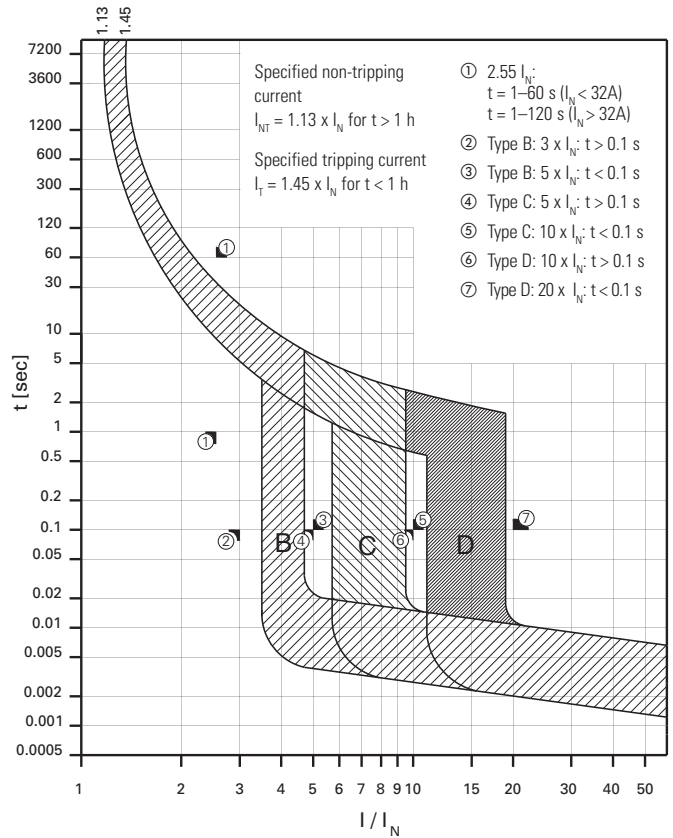

UL 1077 Cable-In / Cable-Out Supplementary Protectors

WMZS Circuit Breakers

PRODUCT SELECTION

Pin Type Incoming Supply Terminals

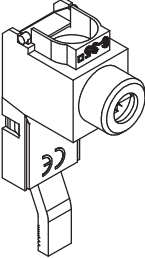
Accessories	Description	Catalog Number
Incoming Terminal		
	<ul style="list-style-type: none"> Accommodates conductors from 6–35 mm² / #10–2 AWG 4–5.5 Nm / 35–50 lb-in Finger-safe connection 	WMZS35EXT

Protective Accessories

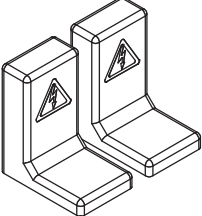
Accessories	Description	Catalog Number
Busbar Terminal Cover		
	For covering unused terminals	WMZSBBTC

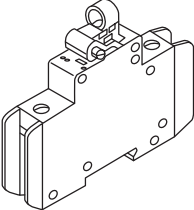

Padlock Hasp

	<ul style="list-style-type: none"> Prevents reactivation of the device during maintenance Holds one padlock 	WMZPLK
--	---	---------------

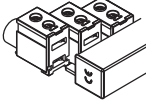
Bus Incoming Supply Terminals

Accessories	Description	Catalog Number
Incoming Terminal		
	<ul style="list-style-type: none"> 50 mm² #14–1 AWG 75 deg wire 115 A/Y, 480V UL 160 A/Y 690V IEC 	WMZSBCONA

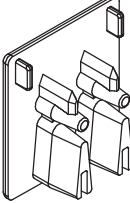
Busbar End Cap

Accessories	Description	Poles	Catalog Number
Fork Connector			
	<ul style="list-style-type: none"> Install after cutting busbar Protects end of busbar 	2 and 3	WMZS3CAP
		1	WMZS1CAP

UL 1077 Cable-In / Cable-Out Supplementary Protectors

WMZS Circuit Breakers

TECHNICAL DATA

Technical Data

Description	B Curve	C Curve	D Curve
Electrical			
Approvals	UR (UL 1077), CSA (CSA 22.2 No. 235), CE		
Standards	IEC/EN 60947-2		
Short-circuit trip response	$3 \times 5 I_n$	$5 \times 10 I_n$	$10 \times 20 I_n$
Supplementary Protectors—UL/CSA			
Current range	6–63A	0.5–63A	0.5–40A
Maximum voltage ratings—UL/CSA			
Single-pole	277 Vac 48 Vdc	277 Vac 48 Vdc	277 Vac 48 Vdc
Two-, three-pole	480Y/277 Vac	480Y/277 Vac	480Y/277 Vac
Two poles in series	96 Vdc	96 Vdc	96 Vdc
Thermal tripping characteristics			
Single-pole	$1.35 \times I_n @ 40^\circ\text{C}$	$1.35 \times I_n @ 40^\circ\text{C}$	$1.35 \times I_n @ 40^\circ\text{C}$
Multi-pole	$1.45 \times I_n @ 40^\circ\text{C}$	$1.45 \times I_n @ 40^\circ\text{C}$	$1.45 \times I_n @ 40^\circ\text{C}$
Short-circuit ratings (at max. voltage)			
Single-pole	10 kA (5 kA for 40–63A device)	10 kA (5 kA for 40–63A device)	5 kA
Two-, three-pole	10 kA (5 kA for 40–63A device)	10 kA (5 kA for 40–63A device)	5 kA
Single-pole	10 kA @ 48 Vdc	10 kA @ 48 Vdc	10 kA @ 48 Vdc
Two poles in series	10 kA @ 96 Vdc	10 kA @ 96 Vdc	10 kA @ 96 Vdc
Miniature Circuit Breaker—IEC			
Current range	6–63A	0.5–63A	0.5–40A
Maximum voltage ratings—IEC 60947-2			
Single-pole	230 Vac 48 Vdc	230 Vac 48 Vdc	230 Vac 48 Vdc
Two-, three-pole	230/400 Vac	230/400 Vac	230/400 Vac
Maximum voltage ratings—IEC 60898			
Single-pole	240 Vac 48 Vdc	240 Vac 48 Vdc	240 Vac 48 Vdc
Two-, three-pole	240/415 Vac	240/415 Vac	240/415 Vac
Thermal tripping characteristics			
Single-pole	> 1 Hour @ $1.05 \times I_n$	> 1 Hour @ $1.05 \times I_n$	> 1 Hour @ $1.05 \times I_n$
Multi-pole	< 1 Hour @ $1.3 \times I_n$	< 1 Hour @ $1.3 \times I_n$	< 1 Hour @ $1.3 \times I_n$
Interrupt ratings (at max. voltage)			
IEC 60947-2	15 kA	15 kA	15 kA
IEC 60898	10 kA	10 kA	10 kA
Operational switching capacity	7.5 kA	7.5 kA	7.5 kA
Max. backup fuse (gL/gG)	125A	125A	125A
Rated impulse withstand— U_{imp}	4000 Vac	4000 Vac	4000 Vac
Rated insulation voltage— U_i	440 Vac	440 Vac	440 Vac
Environmental/General			
Selectivity class	3	3	3
Lifespan (operations)	> 10000 (1 operation = ON/OFF)	> 10000 (1 operation = ON/OFF)	> 10000 (1 operation = ON/OFF)
Shock (IEC 68-2-22)	10g–120 ms	10g–120 ms	10g–120 ms
Operating temperature range	+23 to +104°F (–5 to +40°C)	+23 to +104°F (–5 to +40°C)	+23 to +104°F (–5 to +40°C)
Shipment and short-term storage	–40 to +185°F (–40 to +85°C)	–40 to +185°F (–40 to +85°C)	–40 to +185°F (–40 to +85°C)
Housing material	Nylon	Nylon	Nylon
Mechanical			
Standard front dimension	80 mm	80 mm	80 mm
Device height	80 mm	80 mm	80 mm
Terminal protection	Finger and back-of-hand proof to IEC 536	Finger and back-of-hand proof to IEC 536	Finger and back-of-hand proof to IEC 536
Mounting width per pole	17.5 mm	17.5 mm	17.5 mm
Mounting	IEC/EN 60715 top-hat rail	IEC/EN 60715 top-hat rail	IEC/EN 60715 top-hat rail
Degree of protection	IP20	IP20	IP20
Terminals top and bottom	Twin-purpose terminals	Twin-purpose terminals	Twin-purpose terminals
Supply connection	Line or load side	Line or load side	Line or load side
Terminal capacity (mm ²)	1 x 25 (AWG 4–18) / 2 x 10 (AWG 8–18)	1 x 25 (AWG 4–18) / 2 x 10 (AWG 8–18)	1 x 25 (AWG 4–18) / 2 x 10 (AWG 8–18)
Torque	2.4 Nm	2.4 Nm	2.4 Nm
Imperial torque	21 lb-in (AWG 18–12), 25 lb-in (AWG 10–8), 36 lb-in (AWG 6–4)	21 lb-in (AWG 18–12), 25 lb-in (AWG 10–8), 36 lb-in (AWG 6–4)	21 lb-in (AWG 18–12), 25 lb-in (AWG 10–8), 36 lb-in (AWG 6–4)
Thickness of busbar material	0.8–2 mm	0.8–2 mm	0.8–2 mm
Mounting position	As required	As required	As required

UL 1077 Cable-In / Cable-Out Supplementary Protectors

WMZS Circuit Breakers

TECHNICAL DATA

Let-Through Energy I^2t

Characteristic B and C

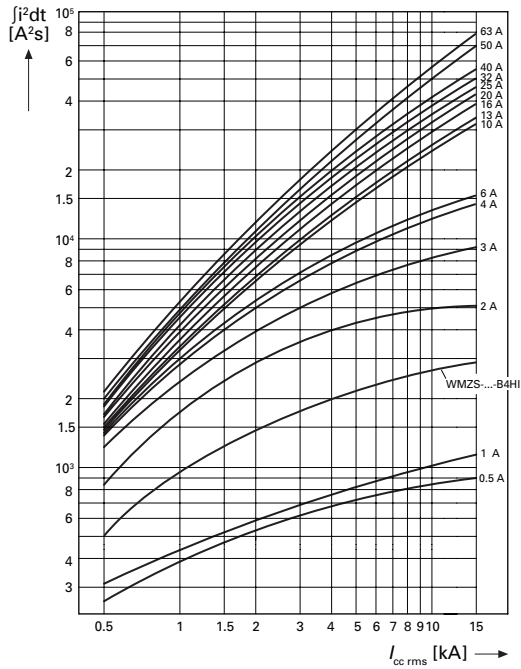

Let-Through Current I_D

Characteristic B and C

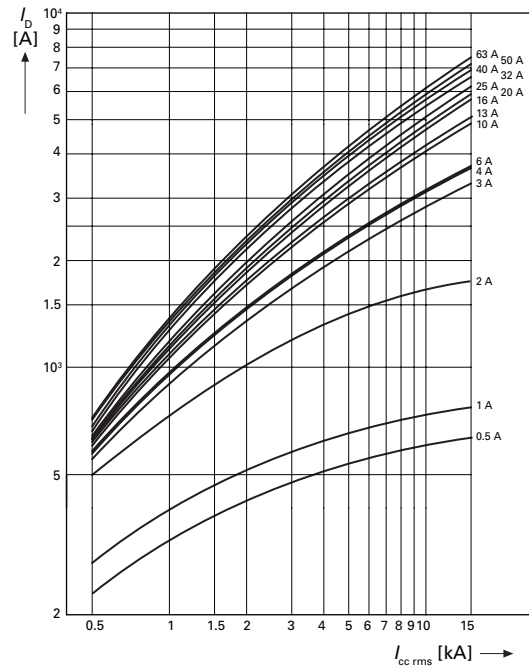

Characteristic D

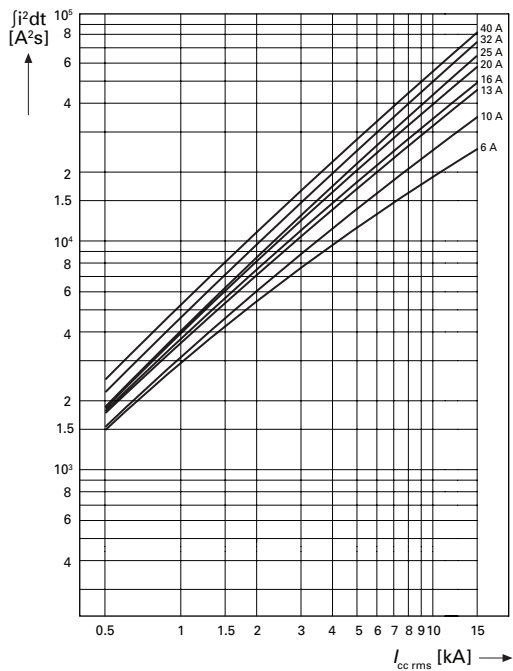

Characteristic D

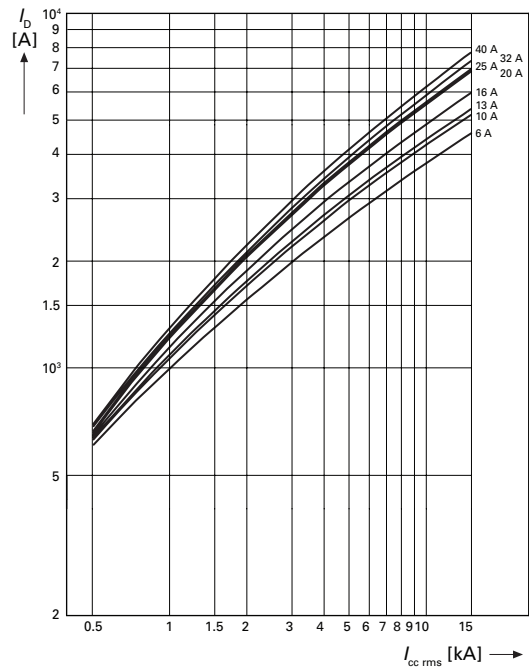

UL 1077 Cable-In / Cable-Out Supplementary Protectors

WMZS Circuit Breakers

TECHNICAL DATA

Influence of the Ambient Temperature on the Thermal Tripping Behavior

Corrected values of the rated current dependent on the ambient temperature

I_n (A)	Ambient Temperature T												
	-25°C	-20°C	-10°C	0°C	10°C	20°C	30°C	35°C	40°C	45°C	50°C	55°C	60°C
0.16	0.20	0.19	0.19	0.18	0.17	0.17	0.16	0.16	0.15	0.15	0.15	0.14	0.14
0.25	0.31	0.30	0.29	0.28	0.27	0.26	0.25	0.25	0.24	0.24	0.23	0.23	0.22
0.5	0.61	0.60	0.58	0.56	0.54	0.52	0.50	0.49	0.48	0.47	0.46	0.45	0.44
0.75	0.92	0.90	0.87	0.84	0.81	0.78	0.75	0.74	0.73	0.71	0.69	0.68	0.66
1	1.2	1.2	1.2	1.1	1.1	1.0	1.0	0.99	0.97	0.95	0.93	0.90	0.89
1.5	1.8	1.8	1.7	1.7	1.6	1.6	1.5	1.5	1.5	1.4	1.4	1.4	1.3
1.6	2.0	1.9	1.9	1.8	1.7	1.7	1.6	1.6	1.5	1.5	1.5	1.4	1.4
2	2.4	2.4	2.3	2.2	2.2	2.1	2.0	2.0	1.9	1.9	1.9	1.8	1.8
2.5	3.1	3.0	2.9	2.8	2.7	2.6	2.5	2.5	2.4	2.4	2.3	2.3	2.2
3	3.7	3.6	3.5	3.4	3.3	3.1	3.0	3.0	2.9	2.8	2.8	2.7	2.7
3.5	4.3	4.2	4.1	3.9	3.8	3.7	3.5	3.4	3.4	3.3	3.2	3.2	3.1
4	4.9	4.8	4.7	4.5	4.3	4.2	4.0	3.9	3.9	3.8	3.7	3.6	3.5
5	6.1	6.0	5.8	5.6	5.4	5.2	5.0	4.9	4.8	4.7	4.6	4.5	4.4
6	7.3	7.2	7.0	6.7	6.5	6.3	6.0	5.9	5.8	5.7	5.6	5.4	5.3
7	8.6	8.4	8.1	7.9	7.6	7.4	7	6.9	6.8	6.7	6.6	6.4	6.3
8	9.8	9.6	9.3	9.0	8.7	8.4	8.0	7.9	7.7	7.6	7.4	7.2	7.1
10	12	12	12	11	11	10	10	9.9	9.7	9.5	9.3	9.0	8.9
12	15	14	14	13	13	13	12	12	12	11	11	11	11
13	16	16	15	15	14	14	13	13	13	12	12	12	12
15	18	18	17	17	16	16	15	15	15	14	14	14	13
16	20	19	19	18	17	17	16	16	15	15	15	14	14
20	24	24	23	22	22	21	20	20	19	19	19	18	18
25	31	30	29	28	27	26	25	25	24	24	23	23	22
32	39	38	37	36	35	33	32	32	31	30	30	29	28
40	49	48	47	45	43	42	40	39	39	38	37	36	35
50	61	60	58	56	54	52	50	49	48	47	46	45	44
63	77	76	73	71	68	66	63	62	61	60	58	57	56

Influence of the Mains Frequency

Influence of the mains frequency on the tripping behavior I_{MA} of the instantaneous release

$I_{MA}(f)/I_{MA}(50\text{ Hz})$ [%]	Mains Frequency f [Hz]						
	16-2/3	50	60	100	200	300	400
	91	100	101	106	115	134	141

Load Carrying Capacity of Adjoining Miniature Circuit Breakers

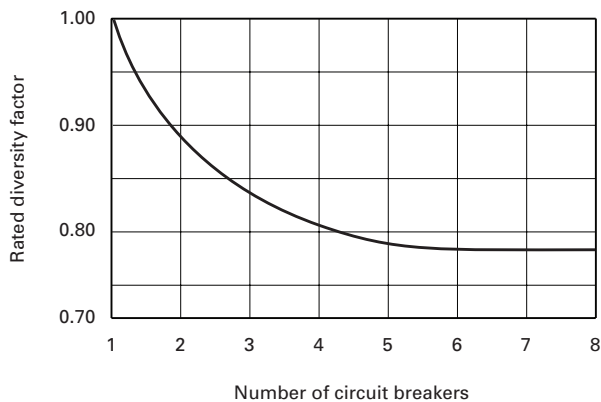





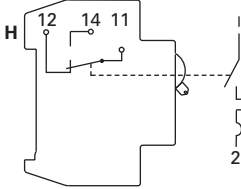

UL 1077 Cable-In / Cable-Out Supplementary Protectors

WMZS Circuit Breakers

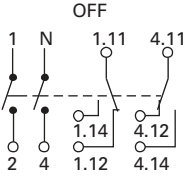
TECHNICAL DATA

Auxiliary Contacts and Voltage Trips

Module	Circuit Diagram	Description	Rated Operational Voltage	Catalog Number
Standard Auxiliary Contacts				
		<ul style="list-style-type: none"> • 1NO/1NC • Installs on left side of WMZS or shunt trip • Max. one per WMZS (1077) device • Switches when WMZS is tripped electrically or manually 	230 Vac	WMZSAUX
Auxiliary/Trip Indicating Contact				
		<ul style="list-style-type: none"> • Small selector screw changes mode • Two Form C (changeover) contacts • Installs on left side of WMZS or shunt trip • Auxiliary contacts switch when WMZS is tripped electrically or manually • Trip indicating contact switches only when WMZS is tripped electrically 	230 Vac	WMZSAUXTRIP
Undervoltage Trip				
		<ul style="list-style-type: none"> • Prevents WMZS from operating unless voltage is present 	115 Vac	WMZSUVR115
		<ul style="list-style-type: none"> • Installs on left side of WMZ 	230 Vac	WMZSUVR230
		<ul style="list-style-type: none"> • Includes Test button 	400 Vac	WMZSUVR400
Shunt Trip				
		<ul style="list-style-type: none"> • Allows remote trip of WMZS • Installs on left side of WMZS 	110–415 Vac 110–230 Vdc	WMZSST415
			12–110 Vac 12–60 Vdc	WMZSST110

Allowable Combinations of Accessories

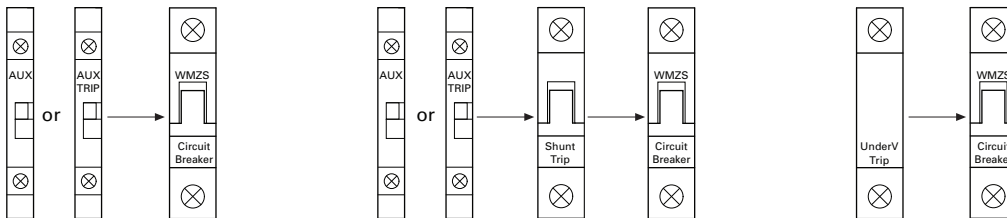

UL 1077 Cable-In / Cable-Out Supplementary Protectors

WMZS Circuit Breakers

TECHNICAL DATA

Busbar System

Description	Rated Operational Current (A)	Number of Poles per Device	Number of Terminals	Catalog Number	
Without Auxiliary Contacts For connecting WMZS Supplementary Protectors without auxiliary contacts. May be fed from line or load side.	80	1	57	WMZS1P57T	
		2	56	WMZS2P56T	
		3	57	WMZS3P57T	
	100	1	57	WMZS1P57T25	
		2	56	WMZS2P56T25	
		3	57	WMZS3P57T25	
	Auxiliary/Trip Indicating Contact For connecting WMZS Supplementary Protectors with auxiliary contacts. May be fed from line or load side.	80	1	37	WMZS1P37TAUX
			2	46	WMZS2P46TAUX
			3	48	WMZS3P48TAUX
100		1	37	WMZS1P37T25AUX	
		2	46	WMZS2P46T25AUX	
		3	48	WMZS3P48T25AUX	

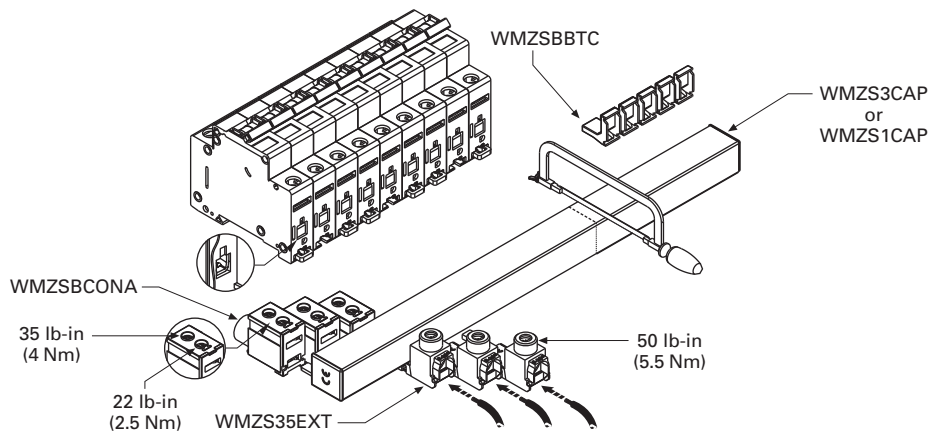
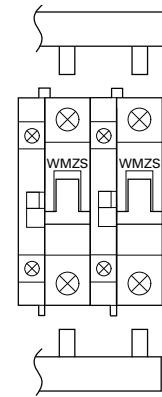
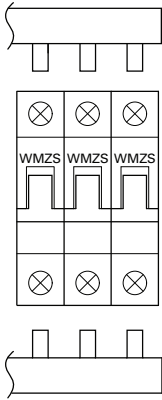

UL 1077 Cable-In / Cable-Out Supplementary Protectors

WMZS Circuit Breakers

TECHNICAL DATA

Technical Data

Description	WMZSAUX WMZSAUXTRIP	WMZSST	WMZSUVR
Electrical			
Contact function	1A + 1B 2 C/O	—	—
Rated operational voltage U_n	250 Vac	—	115 Vac—WMZSUVR115 230 Vac—WMZSUVR230 400 Vac—WMZSUVR400
Voltage range WMZSST110	—	12–110 Vac 12–60 Vdc	—
Voltage range WMZSST415	—	110–415 Vac 110–230 Vdc	—
Closing threshold (x U_n)	—	—	0.8
Tripping threshold (x U_n)	—	—	0.5
Rated frequency f	50/60 Hz	50/60 Hz	50/60 Hz
General use (UL/CSA)			
AC—230/240 Vac	2/2A	—	—
DC—110/120 Vdc	0.5/0.5A	—	—
Pilot duty	A600/Q600	—	—
Conventional free air thermal current I_{th}	4A	—	—
Rated operational current			
AC-13 I_o	3A (250 Vac)	—	—
AC-15 I_o	2A (250 Vac)	—	—
DC-13 I_o	0.5A (110 Vdc)	—	—
Rated insulation voltage U_i	250 Vac	—	—
Minimum operating voltage per contact U_{min}	5 Vdc	—	—
Rated impulse withstand voltage (1.2/50 μ) U_{imp}	2.5 kV	—	—
Rated conditional short-circuit current with 6A backup fuse I_{sc}	1 kA	—	—
Maximum admissible backup fuse	4A gL	—	—
Mechanical			
Standard front dimension	45 mm	45 mm	45 mm
Device height	80 mm	80 mm	80 mm
Mounting width	8.8 mm	17.6 mm	17.8 mm
Mounting	On MCB	IEC/EN 60715 top-hat rail	IEC/EN 60715 top-hat rail
Degree of protection—enclosed	IP40	IP40	IP40
Terminal protection	Protection against electric shock to IEC 536	Protection against electric shock to IEC 536	Protection against electric shock to IEC 536
Terminals	Lift terminals	Twin-purpose terminals	Twin-purpose terminals
Terminal capacity			
Solid	0.5–2.5 mm ²	1–2.5 mm ²	2 x (1–2.5) mm ²
Flexible	0.5–2.5 mm ²	1–2.5 mm ²	2 x (1–2.5) mm ²
Tightening torque of terminal screws	0.8–1.0 Nm (7–9 lb-in)	2.4 Nm (21 lb-in)	0.8 Nm (7 lb-in)

UL 1077 Cable-In / Cable-Out Supplementary Protectors

WMZS Circuit Breakers

TECHNICAL DATA

Dimensions

Miniature Circuit Breakers

WMZS

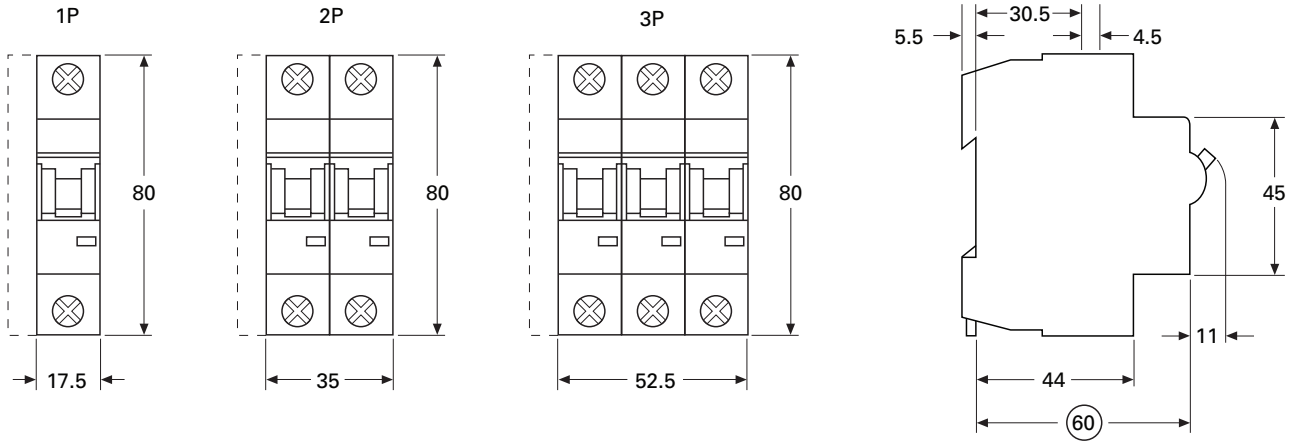

Auxiliary Contacts

WMZSAUX

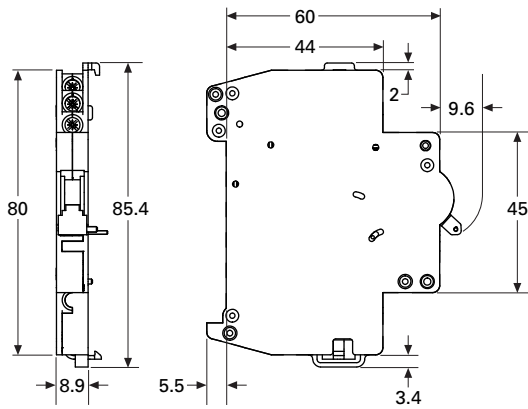

Shunt Releases

WMZSST

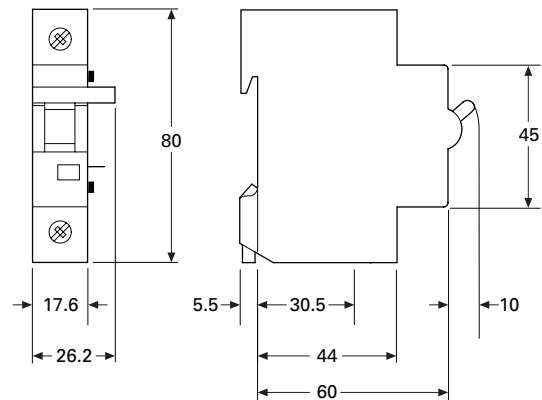

WMZSAUXTRIP

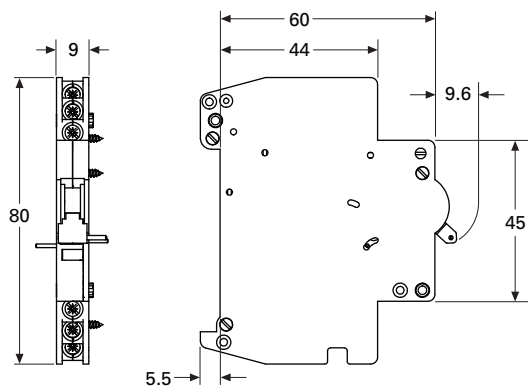

Undervoltage Releases

WMZSUVR

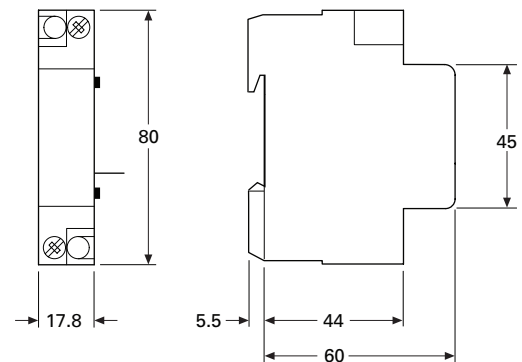

UL 1077 Cable-In / Cable-Out Supplementary Protectors

WMZS Circuit Breakers

TECHNICAL DATA

Busbar and Accessory Weights and Dimensions

Catalog Number	Unit Weight (kg)	Length (mm)	Width (mm)	Height (mm)
WMZS1P57T	0.29	1009	15	15
WMZS2P56T	0.64	991	22	37
WMZS3P57T	0.83	1009	22	37
WMZS1P37TAUX	0.26	985	15	15
WMZS2P46TAUX	0.63	1009	22	37
WMZS3P48TAUX	0.79	982	22	37
WMZS1P57T25	0.36	1009	15	15
WMZS2P56T25	0.79	991	22	37
WMZS3P57T25	1.04	1009	22	37
WMZS1P37T25AUX	0.31	985	15	15
WMZS2P46T25AUX	0.73	1009	22	37
WMZS3P48T25AUX	0.97	982	22	37
WMZS35EXT	0.03	60	17	29
WMZSBCONA	0.03	40	18	30
WMZSBBTC	0.003	85	12	24
WMZS1CAP	0.001	14	5	10
WMZS3CAP	0.001	24	22	10

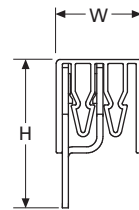
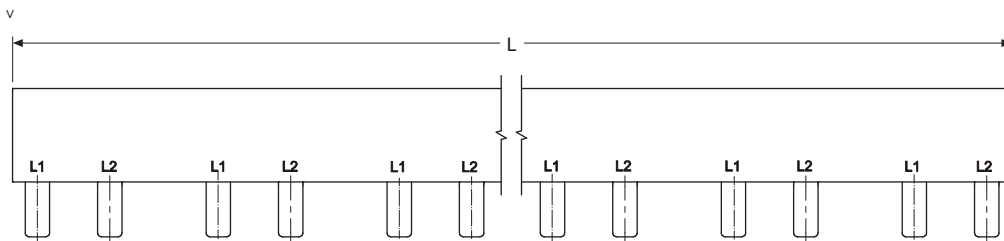

Eaton's Electrical Sector is a global leader in power distribution, power quality, control and automation, and monitoring products. When combined with Eaton's full-scale engineering services, these products provide customer-driven PowerChain™ solutions to serve the power system needs of the data center, industrial, institutional, public sector, utility, commercial, residential, IT, mission critical, alternative energy and OEM markets worldwide.

PowerChain solutions help enterprises achieve sustainable and competitive advantages through proactive management of the power system as a strategic, integrated asset throughout its life cycle, resulting in enhanced safety, greater reliability and energy efficiency. For more information, visit www.eaton.com/electrical.

Eaton Corporation
Electrical Sector
1111 Superior Ave.
Cleveland, OH 44114
United States
877-ETN-CARE (877-386-2273)
Eaton.com

© 2011 Eaton Corporation
All Rights Reserved
Printed in USA
Publication No. PG01101008E / Z9904
April 2011



Eaton is a registered trademark of Eaton Corporation.

All other trademarks are property of their respective owners.

X-ON Electronics

Largest Supplier of Electrical and Electronic Components

Click to view similar products for [eaton](#) manufacturer:

Other Similar products are found below :

[BK-MDL-3-R](#) [BK1-S506-500-R](#) [BK1-S506-6-3-R](#) [BK1-S506-2-R](#) [MPI4040R4-1R5-R](#) [TDC600-10A](#) [89096-015](#) [8946K153](#) [8961K155](#)
[M22-DL-W-X0](#) [M22-D-R-GB0/K11](#) [M22-L-R/R](#) [M22S-ST-GB12](#) [630NHG3B](#) [63ET](#) [6422](#) [6580](#) [CTX20-16-52LP-R](#) [CWL530FI](#)
[CXM/CO/GP/R/BB](#) [6HD36](#) [714125](#) [MBO-2](#) [ESR5-NO-41-24VAC-DC](#) [7314K36](#) [7321K2](#) [F02A-1-1/2A](#) [F02A-1-1/2AS](#) [F02A-1AS](#) [F02A-2AS](#) [F02A-3/4A](#) [F03A250V12A](#) [F03B125V4A](#) [MCR-4](#) [MDA-2-8/10-R](#) [MDA-30A](#) [MDA-V-1/16](#) [F60C500V10AS](#) [F60C500V15AS](#)
[7563K84](#) [7634K36](#) [MDQ-3/16](#) [MDQ-7/10](#) [MDQ-V-1/10](#) [MDQ-V-1-1/4](#) [MDQ-V-1/16](#) [MDQ-V-1/2](#) [MDQ-V-1/4](#) [MDQ-V-3/16](#) [MDQ-V-3/8](#)