

Dual Half Bridge Motor Driver

Features and Benefits

- Low $R_{DS(on)}$ outputs
- Standby mode with zero current drain
- Small 2×2 DFN package
- Crossover Current protection
- Thermal Shutdown protection

Package: 8-contact DFN with Exposed Thermal Pad (suffix EE)

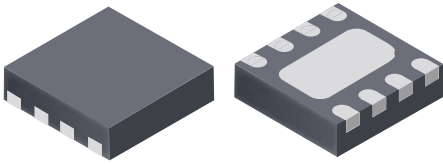

Not to scale

Description

The A3910 is a dual half bridge motor driver, designed for low cost, low voltage battery operated power applications. The outputs are rated for operation up to 500 mA.

Direct control of high- and low-side drivers is implemented to allow either high-side or low-side PWM. The motor can be connected to either supply or GND. Using a MOS switch results in improved braking action for the motor, compared to implementation with simple clamp diode.

The A3910 is supplied in a $2 \text{ mm} \times 2 \text{ mm}$ 8-contact DFN package (EE) with exposed thermal pad. The package is lead (Pb) free, with 100% matte tin leadframe plating.

Typical Application Diagram

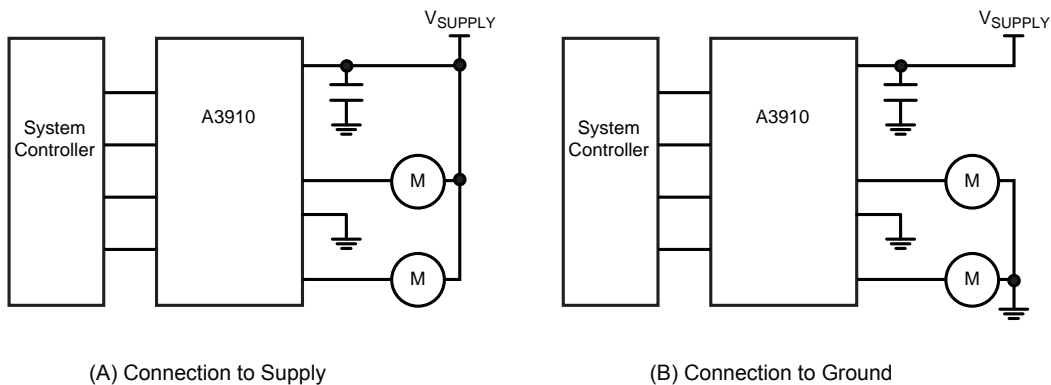

Selection Guide

Part Number	Packing*	Package
A3910EEETR-T	3000 pieces per 7-in. reel	8-contact DFN with exposed thermal pad

*Contact Allegro™ for additional packing options.

Absolute Maximum Ratings*

Characteristic	Symbol	Notes	Rating	Unit
Supply Voltage	V_{BB}		-0.3 to 5.5	V
Logic Input Voltage Range	V_{IN}		-0.3 to 6	V
Output Current	I_{OUT}		500	mA
Output Voltage	V_{OUT}		-0.3 to $V_{BB} + 1$	V
Operating Ambient Temperature	T_A	E temperature range	-40 to 85	°C
Maximum Junction Temperature	$T_{J(max)}$		150	°C
Storage Temperature	T_{stg}		-55 to 150	°C

Thermal Characteristics may require derating at maximum conditions, see application information

Characteristic	Symbol	Test Conditions*	Value	Unit
Package Thermal Resistance	$R_{\theta JA}$	On 4-layer PCB based on JEDEC standard	49	°C/W
		On 2-layer PCB based with 0.23 in. ² exposed copper each side	92	°C/W

*Additional thermal information available on the Allegro website.

Pin-out Diagram

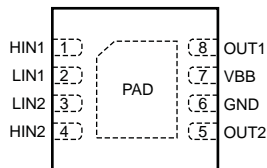

Terminal List Table

Number	Name	Function
1	HIN1	Logic input
2	LIN1	Logic input
3	LIN2	Logic input
4	HIN2	Logic input
5	OUT2	Motor terminal
6	GND	Ground
7	VBB	Input Supply
8	OUT1	Motor terminal

Functional Block Diagram

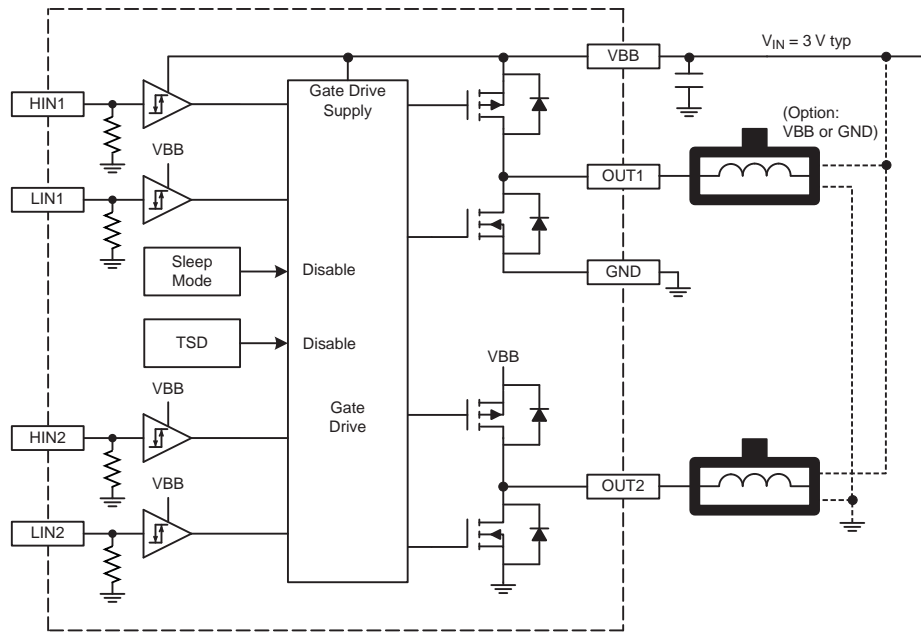

ELECTRICAL CHARACTERISTICS* Valid at $T_A = 25^\circ\text{C}$; unless otherwise specified

Characteristic	Symbol	Test Conditions	Min.	Typ.	Max.	Unit
VBB Supply Range	V_{BB}		2.5	–	5.5	V
VBB Supply Current	I_{BB}	Both bridges, PWM = 50 kHz	–	0.3	1	mA
		Sleep mode (HIN1=HIN2=LIN1=LIN2=0V)	–	<1	1	μA
Output Driver On-Resistance	$R_{DS(on)}$	Source driver, $I = 400\text{ mA}$, $V_{BB} = 3\text{ V}$	–	1.1	1.4	Ω
		Source driver, $I = 400\text{ mA}$, $V_{BB} = 5\text{ V}$	–	0.8	1	Ω
		Sink driver, $I = 400\text{ mA}$, $V_{BB} = 3\text{ V}$	–	0.5	0.65	Ω
		Sink driver, $I = 400\text{ mA}$, $V_{BB} = 5\text{ V}$	–	0.4	0.52	Ω
Input Logic Low Level	V_{IL}		–	–	0.5	V
Input Logic High Level	V_{IH}		$V_{BB}/2$	–	–	V
Input Hysteresis	V_{HYS}		50	150	300	mV
Logic Input Current	I_{IN}	$V_{IN} = 3.3\text{ V}$ (Pulldown = 100 k Ω)	–	33	50	μA
Thermal Shutdown Temperature	T_{JTSD}	Temperature increasing	–	165	–	$^\circ\text{C}$
Thermal Shutdown Hysteresis	ΔT_J	Recovery = $T_{JTSD} - \Delta T_J$	–	15	–	$^\circ\text{C}$

*Specified limits are tested at a single temperature and assured over operating temperature range by design and characterization.

Logic Table

HINx	LINx	OUTx	Function Motor to Supply	Function Motor to GND
0	0	Hi-Z ¹	Coast (Sleep ²)	Coast (Sleep ²)
1	0	High	Brake	Drive
0	1	Low	Drive	Brake
1	1	Hi-Z ¹	Coast	Coast

¹Hi-Z is high impedance.

²Sleep mode activated by all four inputs <100 mV.

Characteristic Performance

Output On-Resistance versus Load Supply Voltage

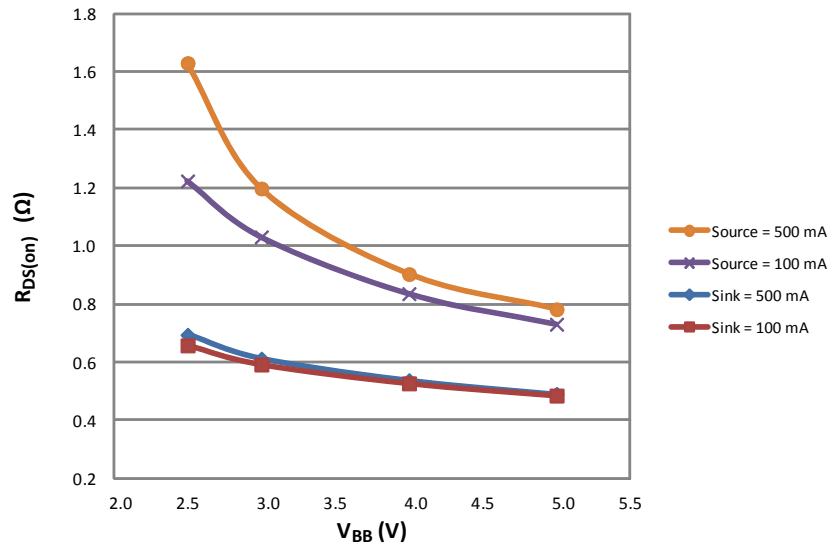

Output On-Resistance versus Output Current

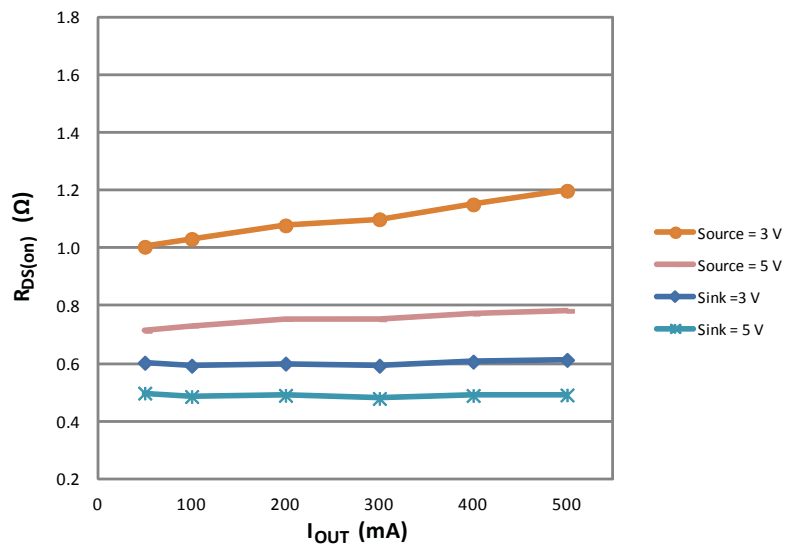

Package EE, 8-Contact DFN
with Exposed Thermal Pad

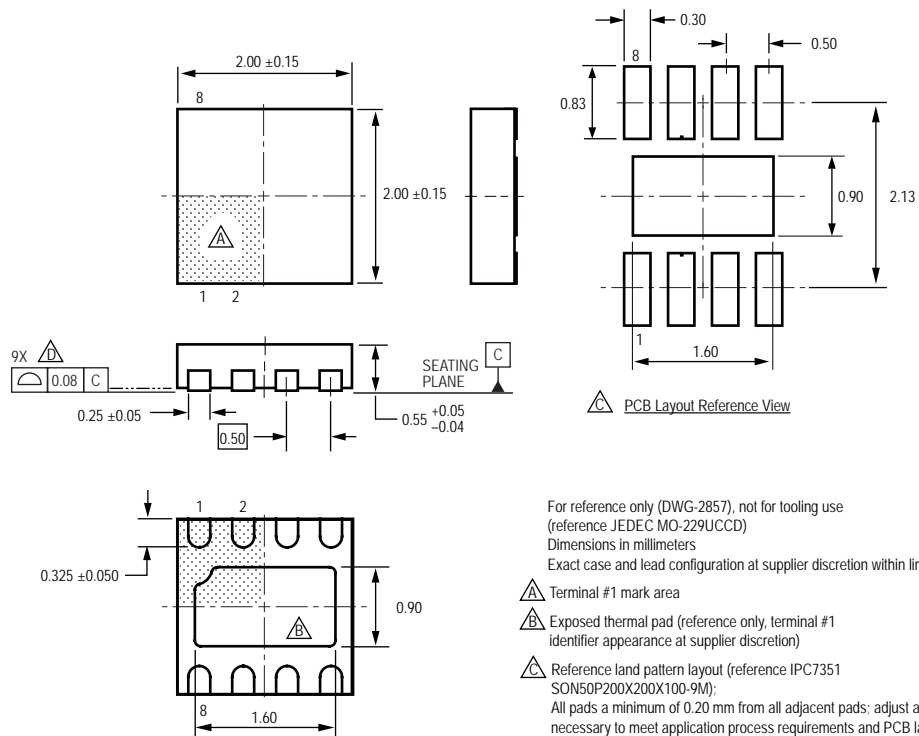

For reference only (DWG-2857), not for tooling use
(reference JEDEC MO-229UCDD)
Dimensions in millimeters
Exact case and lead configuration at supplier discretion within limits shown

- △ Terminal #1 mark area
- △ Exposed thermal pad (reference only, terminal #1 identifier appearance at supplier discretion)
- △ Reference land pattern layout (reference IPC7351 SON50P200X200X100-9M):
All pads a minimum of 0.20 mm from all adjacent pads; adjust as necessary to meet application process requirements and PCB layout tolerances; when mounting on a multilayer PCB, thermal vias at the exposed thermal pad land can improve thermal dissipation (reference EIA/JEDEC Standard JESD51-5)
- △ Coplanarity includes exposed thermal pad and terminals

Revision History

Revision	Revision Date	Description of Revision
Rev. 1	July 23, 2013	Update Selection Guide

Copyright ©2013, Allegro MicroSystems, LLC

Allegro MicroSystems, LLC reserves the right to make, from time to time, such departures from the detail specifications as may be required to permit improvements in the performance, reliability, or manufacturability of its products. Before placing an order, the user is cautioned to verify that the information being relied upon is current.

Allegro's products are not to be used in any devices or systems, including but not limited to life support devices or systems, in which a failure of Allegro's product can reasonably be expected to cause bodily harm.

The information included herein is believed to be accurate and reliable. However, Allegro MicroSystems, LLC assumes no responsibility for its use; nor for any infringement of patents or other rights of third parties which may result from its use.

For the latest version of this document, visit our website:

www.allegromicro.com

X-ON Electronics

Largest Supplier of Electrical and Electronic Components

Click to view similar products for [Motor/Motion/Ignition Controllers & Drivers](#) category:

Click to view products by [Allegro](#) manufacturer:

Other Similar products are found below :

[LV8133JA-ZH](#) [LV8169MUTBG](#) [LV8774Q-AH](#) [LV8860PV-TLM-H](#) [MC33931EKR2](#) [MC34GD3000EP](#) [FSB50250UTD](#) [FSB50550TB2](#)
[FSBF15CH60BTH](#) [MP6507GR-P](#) [MP6508GF](#) [MSVCPM2-63-12](#) [MSVGW45-14-2](#) [MSVGW54-14-5](#) [NTE7043](#) [CAT3211MUTAG](#)
[LA6245P-CL-TLM-E](#) [LA6245P-TLM-E](#) [LA6565VR-TLM-E](#) [LB11650-E](#) [LB1694N-E](#) [LB1837M-TLM-E](#) [LB1845DAZ-XE](#) [LC898111AXB-](#)
[MH](#) [LC898300XA-MH](#) [SS30-TE-L-E](#) [STK531-345A-E](#) [STK581U3A0D-E](#) [STK58AUNP0D-E](#) [STK621-068C-E](#) [STK621-140C](#) [STK621-](#)
[728S-E](#) [STK625-728-E](#) [STK672-400B-E](#) [STK672-432AN-E](#) [STK672-432BN-E](#) [STK672-440AN-E](#) [STK672-442AN-E](#) [AMIS30621AUA](#)
[FSB50550ASE](#) [26700](#) [LV8161MUTAG](#) [LV8281VR-TLM-H](#) [LV8702V-TLM-H](#) [LV8734VZ-TLM-H](#) [LV8773Z-E](#) [LV8807QA-MH](#)
[MC33932EK](#) [MCP8024T-H/MP](#) [TND027MP-AZ](#)