

K430WQA-V4-F

Product

Standard LCD Module
480 x RGB x 272 Dots
4.3" 16.7M colors TFT display
Wide temperature
With white LED backlight
With touch screen

CONTENTS

	<u>Page No.</u>
1. DOCUMENT REVISION HISTORY	3
2. GENERAL DESCRIPTION	4
3. MECHANICAL SPECIFICATIONS	4
4. INTERFACE SIGNALS	6
5. ABSOLUTE MAXIMUM RATINGS	7
6. ELECTRICAL SPECIFICATIONS	7
7. OPTICAL CHARACTERISTICS	8
8. TIMING CHARACTERISTICS	10
9. RELIABILITY TEST ITEM	13
10. SUGGESTIONS FOR USING LCD MODULES	13
11. INSPECTION STANDARD	15
12. PACKING(REFERENCE ONLY)	19



1. Document revision history :

DOCUMENT REVISION	DATE	DESCRIPTION	PREPARED BY	APPROVED BY
01	2009.07.21	First Release.	MF Zou	

2. General Description

- 4.3”(diagonal), 480 x RGB x 272 dots, 16.7M colors, Normal white TN, TFT LCD module.
- Viewing Direction: 6 o’clock.
- RGB 24-bits
- With internal voltage booster.
- Logic voltage: 3.3V (typ.).
- With 4-wire resistive touch screen

3. Mechanical Specifications

The mechanical detail is shown in Fig. 1 and summarized in Table 1 below.

Table 1

Parameter		Specifications	Unit
Outline dimensions		105.5(W) x 67.2(H) x 4.1(D) (Exclude FPC, cables of backlight)	mm
Color TFT 480xRGBx272	View area	98.7(W) x 57.5(H)	mm
	TP view area	98.7(W) x 57.5(H)	mm
	LCD active area	95.04(W) x 53.86(H)	mm
	Display format	480 x RGB x 272	dots
	Color configuration	RGB Side-stripes	-
	Dot size	0.198 (W) x 0.198(RGB)	mm
Weight		TBD	grams

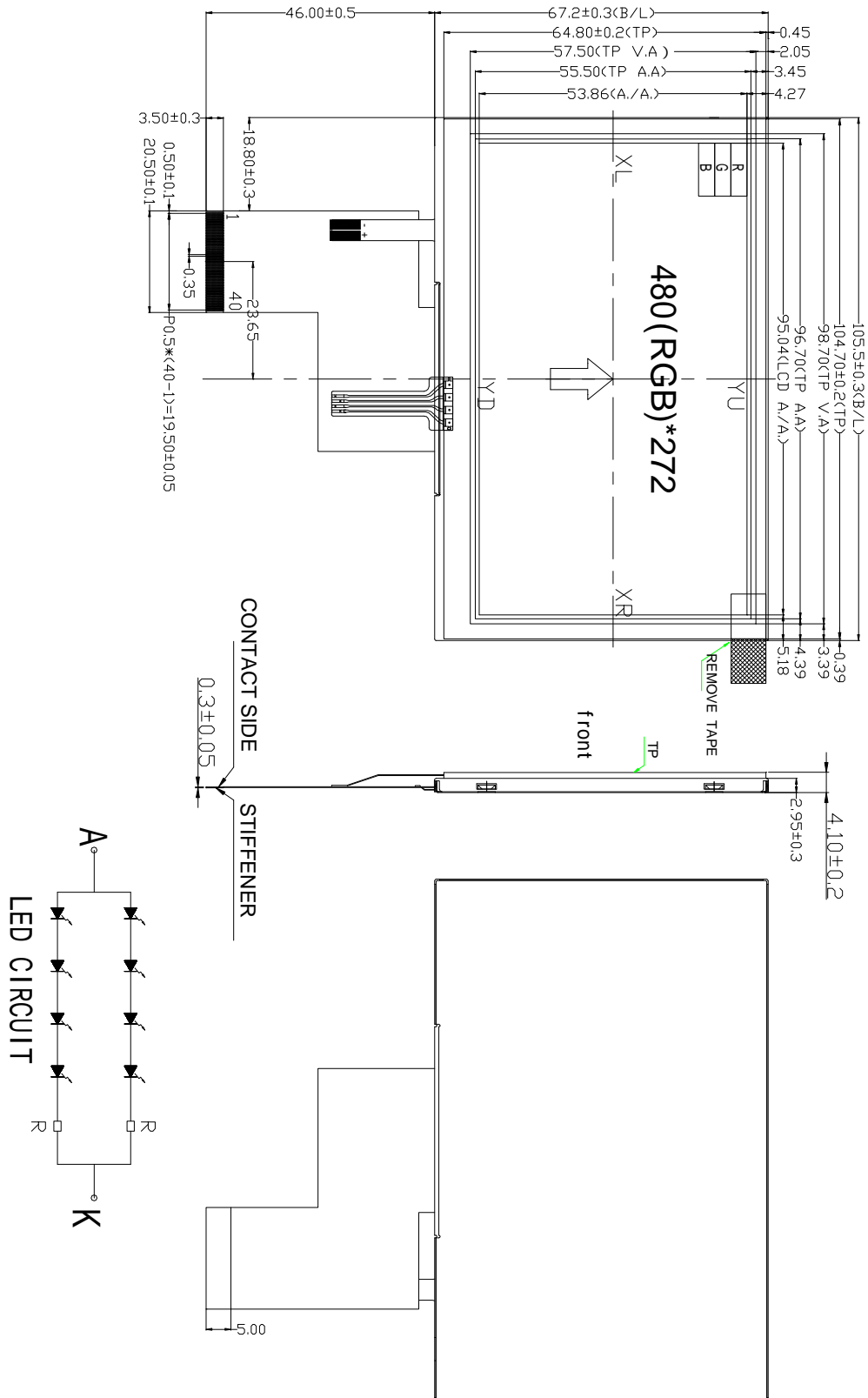

Figure 1: Outline Drawing

4. Interface signals

Table 2: Pin assignment

Pin No	Symbol	I/O	Function
1	V _{LED-}	P	Power for LED backlight cathode
2	V _{LED+}	P	Power for LED backlight anode
3	GND	P	Power ground
4	V _{DD}	P	Power voltage
5	R0	I	Red data (LSB)
6	R1	I	Red data
7	R2	I	Red data
8	R3	I	Red data
9	R4	I	Red data
10	R5	I	Red data
11	R6	I	Red data
12	R7	I	Red data (MSB)
13	G0	I	Green data (LSB)
14	G1	I	Green data
15	G2	I	Green data
16	G3	I	Green data
17	G4	I	Green data
18	G5	I	Green data
19	G6	I	Green data
20	G7	I	Green data (MSB)
21	B0	I	Blue data (LSB)
22	B1	I	Blue data
23	B2	I	Blue data
24	B3	I	Blue data
25	B4	I	Blue data
26	B5	I	Blue data
27	B6	I	Blue data
28	B7	I	Blue data (MSB)
29	GND	P	Power ground
30	DCLK	I	Pixel clock
31	DISP	I	Display on/ off
32	HSYNC	I	Horizontal sync signal
33	VSYNC	I	Vertical sync signal
34	DE	I	Data enable
35	NC	-	No connect
36	GND	P	Power ground
37	X_R	I/O	Right electrode - differential analog
38	Y_B	I/O	Bottom electrode - differential analog
39	X_L	I/O	Left electrode - differential analog
40	Y_T	I/O	Top electrode - differential analog

I/O: I: input, O: output, P: power

5. Absolute Maximum Ratings

5.1 Electrical Maximum Ratings – for IC Only

Table 3: Electrical Maximum Ratings – for IC

Parameter	Symbol	Min.	Max.	Unit	Note
Supply voltage	VCC	-0.3	+4.0	V	1
Input voltage	AVDD	-0.3	+5.0	V	

Note:

- 1.VCC, GND must be maintained.
- 2.The modules may be destroyed if they are used beyond the absolute maximum ratings.

5.2 Environmental Condition

Table 4

Item	Operating temperature (Topr)		Storage temperature (Tstg) (Note 1)		Remark
	Min.	Max.	Min.	Max.	
Ambient temperature	-20°C	+70°C	-30°C	+80°C	Dry
Humidity (Note 1)	80% max. RH for $T_a \leq 40^\circ\text{C}$ < 50% RH for $40^\circ\text{C} < T_a \leq$ Maximum operating temperature				No condensation

Note 1: Product cannot sustain at extreme storage conditions for long time.

6. Electrical Specifications

Typical Electrical Characteristics

At $T_a = 25^\circ\text{C}$, $V_{CC} = I_{OVCC} = 3.3\text{V}$, $GND = 0\text{V}$.

Parameters	Symbol	Min.	Typ.	Max.	Unit	Note
Supply voltage	V_{DD}	3.0	3.3	3.6	V	
Input signal voltage	V_{IH}	$0.7 V_{DD}$	—	V_{DD}	V	Note (1)
	V_{IL}	GND	—	$0.3 V_{DD}$	V	Note (1)
Current of power supply	I_{DD}	—	TBD	—	mA	$V_{DD} = 3.3\text{V}$

Note (1): HSYNC, VSYNC, DE, R/G/B Data

Note (2): GND = 0V

7. Optical Characteristics

Table 7: Optical specifications

Items	Symbol	Condition	Specifications			Unit	Note
			Min.	Typ.	Max.		
Contrast Ratio	CR		150	300	-	-	
Response Time	T_R		-	15	30	ms	
	T_F		-	35	50	ms	
Chromaticity	Red	X_R	0.604	0.624	0.644	-	
		Y_R	0.302	0.322	0.342	-	
	Green	X_G	0.268	0.288	0.308	-	
		Y_G	0.540	0.560	0.580	-	
	Blue	X_B	0.127	0.147	0.167	-	
		Y_B	0.097	0.117	0.137	-	
	White	X_W	-	0.307	-	-	
		Y_W	-	0.328	-	-	
Viewing angle	Hor.	$\phi 1$ (3 o'clock)	-	45	-	deg.	
		$\phi 2$ (9 o'clock)	-	45	-		
	Ver.	$\theta 2$ (12 o'clock)	-	15	-		
		$\theta 1$ (6 o'clock)	-	35	-		
NTSC ratio				61.5		%	

Note 1: Definition of Contrast Ratio (CR):

The contrast ratio can be calculated by the following expression.

$$\text{Contrast Ratio (CR)} = L_{63} / L_0$$

L63: Luminance of gray level 63

L0: Luminance of gray level 0

$$CR = CR(10)$$

CR (X) is corresponding to the Contrast Ratio of the point X at Figure in Note 5.

Note 2: Definition of Response Time (T_R , T_F):

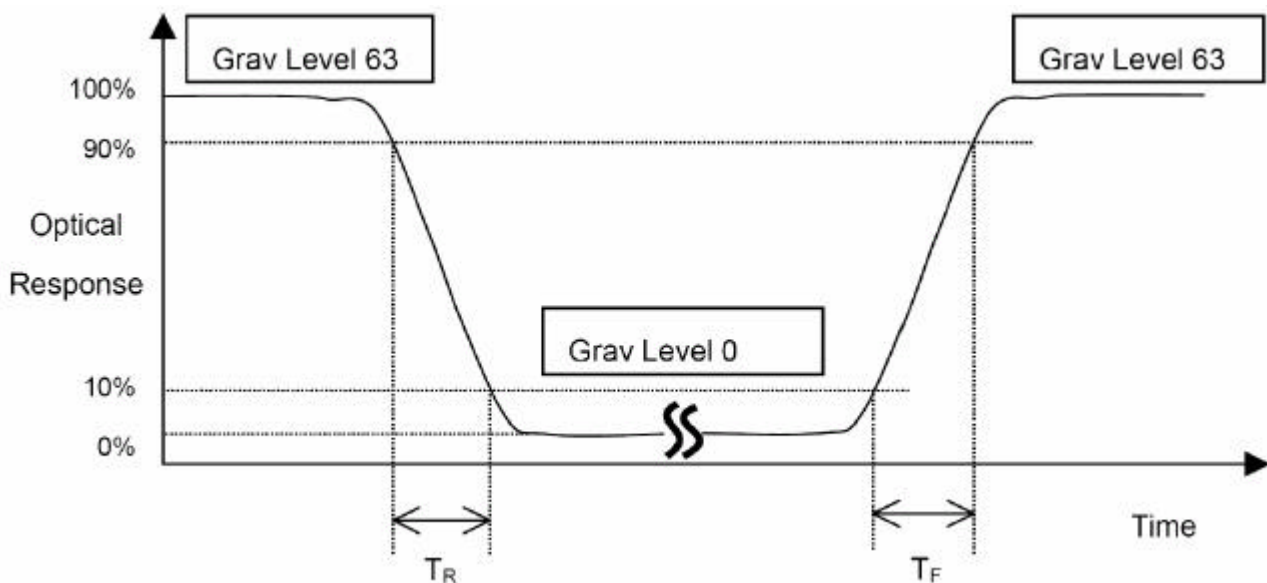

Figure 3

Note 3: Viewing Angle

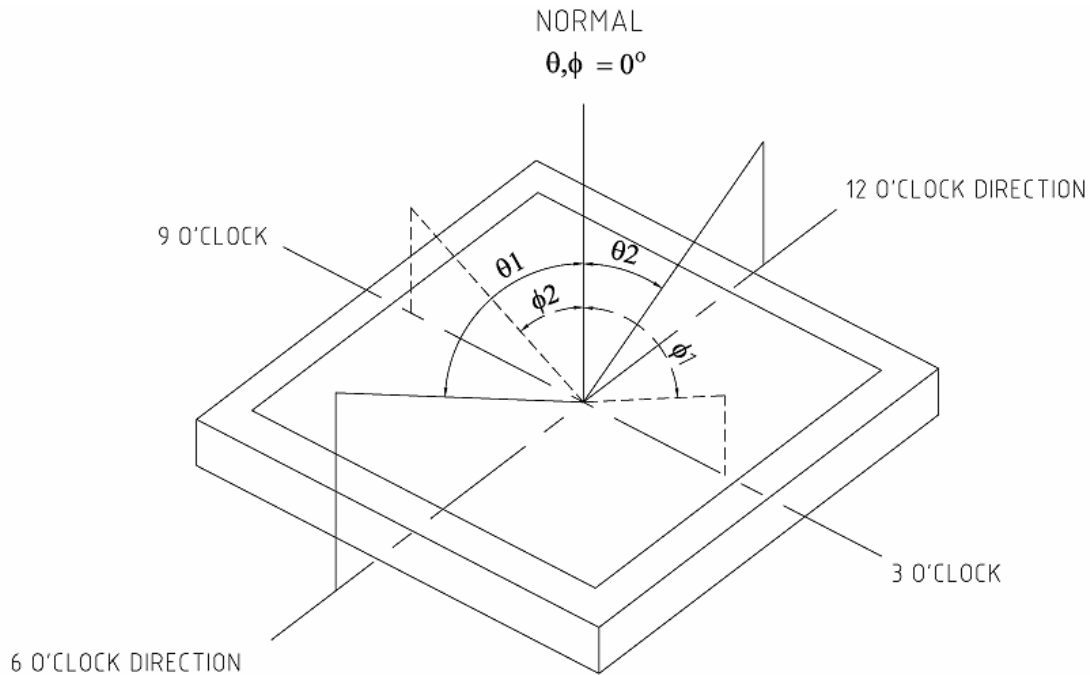

Figure 4

The above “Viewing Angle” is the measuring position with Largest Contrast Ratio; not for good image quality. View Direction for good image quality is 6 O’clock. Module maker can increase the “Viewing Angle” by applying Wide View Film.

Note 4: Measurement Set-Up:

The LCD module should be stabilized at a given temperature for 20 minutes to avoid abrupt temperature change during measuring. In order to stabilize the luminance, the measurement should be executed after lighting Backlight for 20 minutes in a windless room.

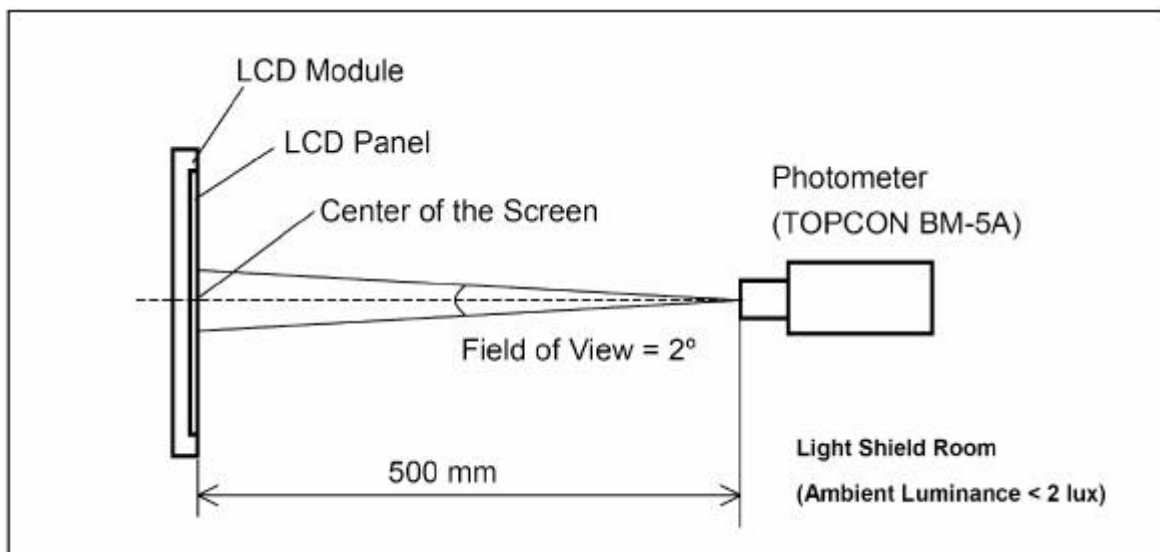
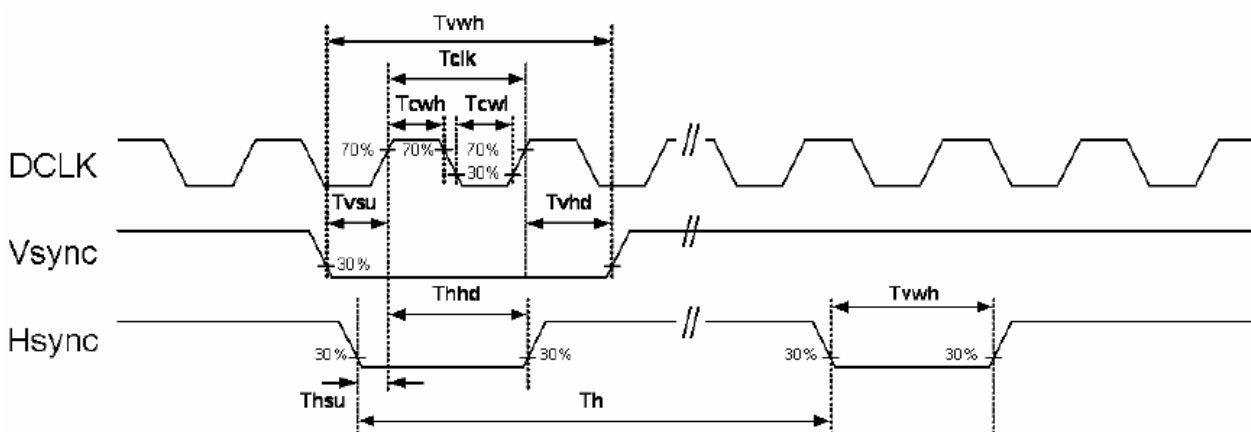
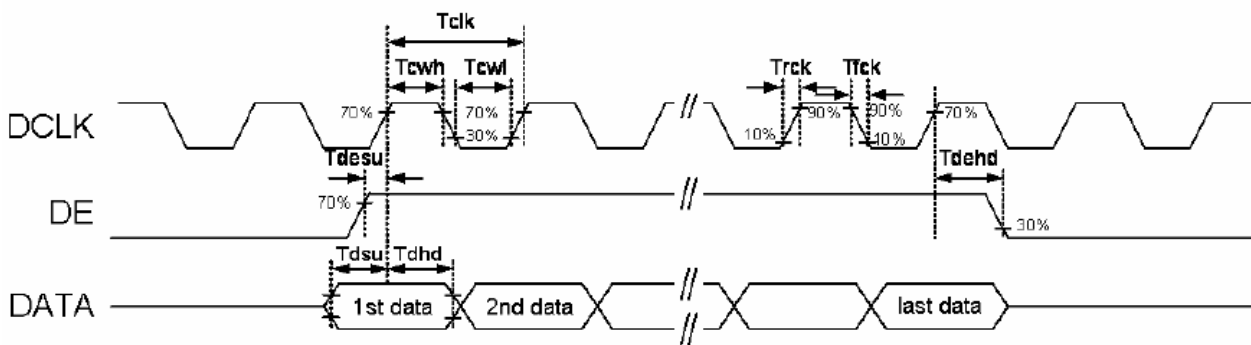

Figure 5

8. AC Characteristics

Parameters	Symbol	Min.	Typ.	Max.	Unit	Conditions
DCLK period time	Tclk	83.3	111.1	200	ns	Parallel 24-bit RGB mode
		33.3	37.0	41.7	ns	Serial 8-bit RGB mode
DCLK rising time	Trck	-	-	9	ns	
DCLK falling time	Tfck	-	-	9	ns	
DCLK pulse duty	Tcwh	40	50	60	%	
DE setup time	Tdesu	12	-	-	ns	
DE hold time	Tdehd	12	-	-	ns	
HSYNC pulse width	Thwh	1	-	-	DCLK	
HSYNC setup time	Thsu	12	-	-	ns	
HSYNC hold time	Thhd	12	-	-	ns	
VSYNC pulse width	Tvwh	1	-	-	Th	
VSYNC setup time	Tvsu	12	-	-	ns	
VSYNC hold time	Tvhd	12	-	-	ns	
Data setup time	Tdsu	12	-	-	ns	
Data hold time	Tdhd	12	-	-	ns	

Clock and Data Input Timing Diagram



Power On Sequence

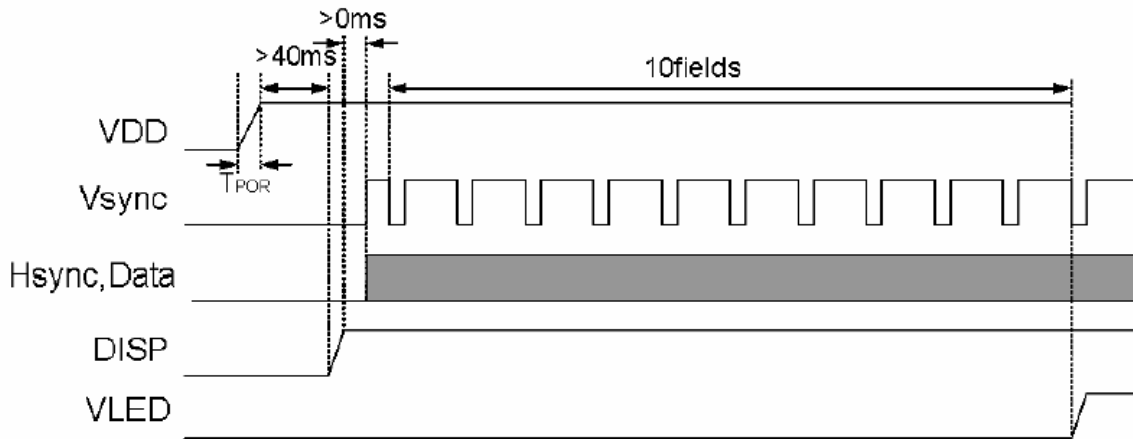

Power Off Sequence

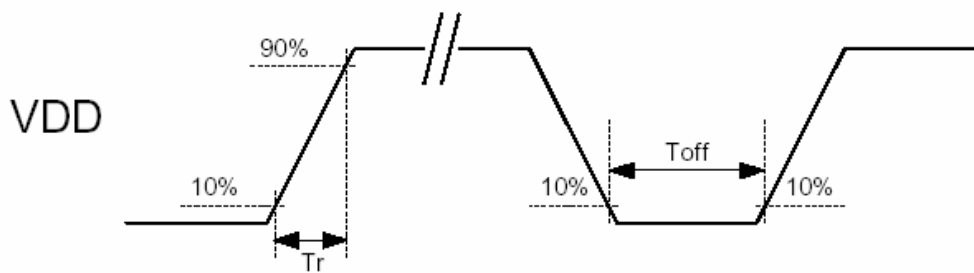
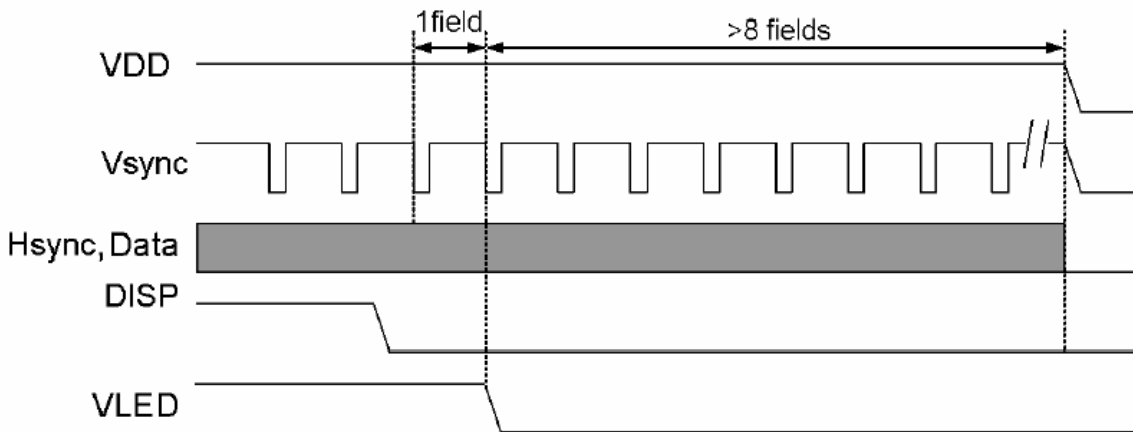

VDD power input timing

Notes:

- Data include R0~R7, G0~G7, B0~B7, HSD, VSD, DCLK, DE
- Power on sequence: VDD → DISP → Data → V_{LED}
- Power off sequence: DISP → V_{LED} → Data → VDD
- VDD power input timing: $0.5\text{ms} < T_r < 10\text{ms}$; $T_{\text{off}} > 500\text{ms}$

Parallel 24-bit RGB Input Timing Table

Parameters	Symbol	Min.	Typ.	Max.	Unit	Conditions
DCLK frequency	fclk	5	9	12	MHz	
VSYNC period time	Tv	277	288	400	Th	
VSYNC display area	Tvd	272			Th	
VSYNC back porch	Tvbp	3	8	31	Th	
VSYNC front porch	Tvfp	2	8	93	Th	
HSYNC period time	Th	520	525	800	DCLK	
HSYNC display area	Thd	480			DCLK	
HSYNC back porch	Thbp	36	40	255	DCLK	
HSYNC front porch	Thfp	4	5	65	DCLK	

Vertical Input Timing

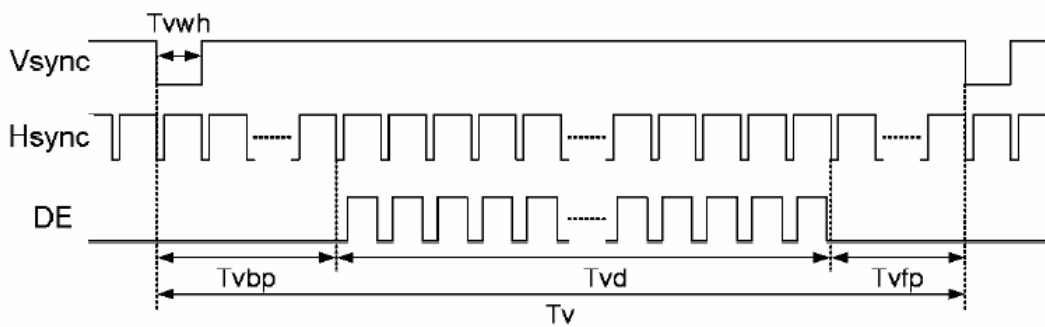

Parallel 24-bit RGB Mode Data Format (DE Mode)

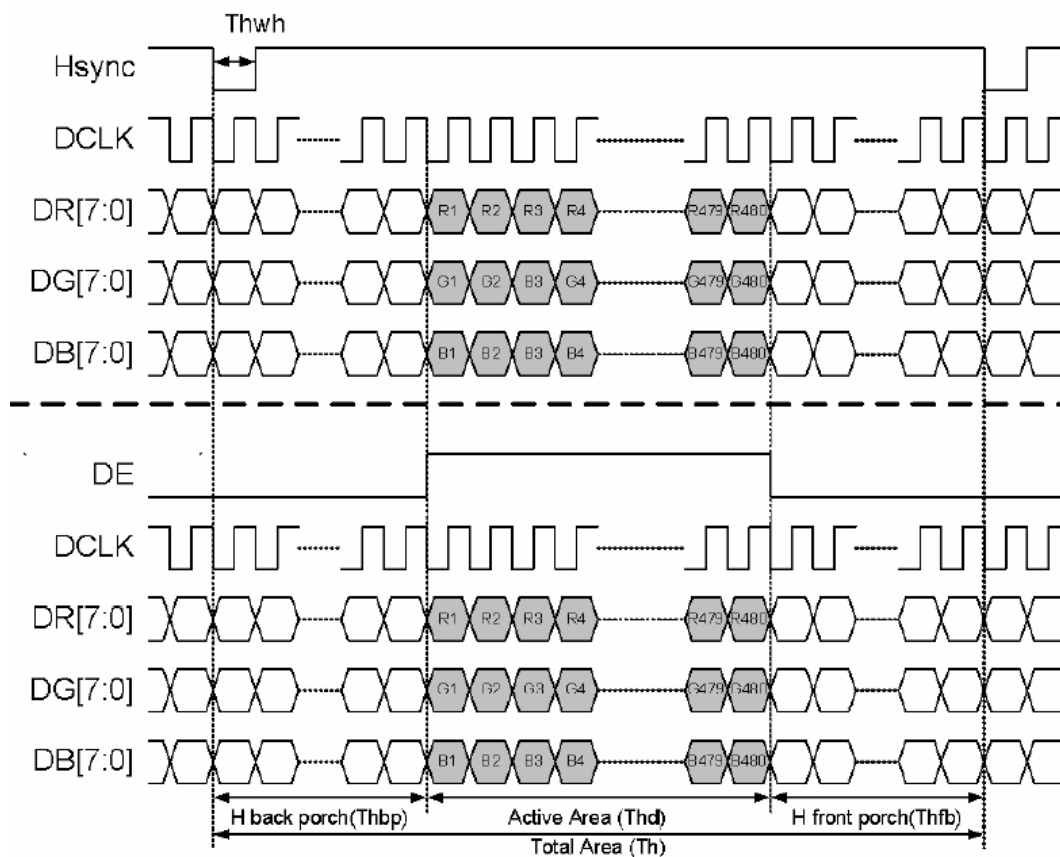

9. Reliability Test Item

Test Item	Test Condition	Test result determinant gist
High temperature storage	80±3 ;96H	the inspection of appearance and function character.
Low temperature storage	-30±3 ;120H	
High temperature /humidity storage	50 ±3 ,90%±3%RH;96H	
High temperature operation	70±3 ;96H	no objection of the function character; no fatal objection of the appearance.
Low temperature operation	-20±3 ;96H	
Temperature Shock	-20±3 ,30min? 70±3 , 30min;10cycle	inspect the objections appearance、 function & the whole structure

10. Suggestions for using LCD modules

10.1 Handling of LCM

1. The LCD screen is made of glass. Don't give excessive external shock, or drop from a high place.
2. If the LCD screen is damaged and the liquid crystal leaks out, do not lick and swallow. When the liquid is attach to your hand, skin, cloth etc, wash it off by using soap and water thoroughly and immediately.
3. Don't apply excessive force on the surface of the LCM.
4. If the surface is contaminated ,clean it with soft cloth. If the LCM is severely contaminated , use Isopropyl alcohol/Ethyl alcohol to clean. Other solvents may damage the polarizer . The following solvents is especially prohibited: water , ketone Aromatic solvents etc.
5. Exercise care to minimize corrosion of the electrode. Corrosion of the electrodes is accelerated by water droplets, moisture condensation or a current flow in a high-humidity environment.
6. Install the LCD Module by using the mounting holes. When mounting the LCD module make sure it is free of twisting, warping and distortion. In particular, do not forcibly pull or bend the I/O cable or the backlight cable.
7. Don't disassemble the LCM.
8. To prevent destruction of the elements by static electricity, be careful to maintain an optimum work

environment.

- Be sure to ground the body when handling the LCD modules.
- Tools required for assembling, such as soldering irons, must be properly grounded.
- To reduce the amount of static electricity generated, do not conduct assembling and other work under dry conditions.
- The LCD module is coated with a film to protect the display surface. Exercise care when peeling off this protective film since static electricity may be generated.

9. Do not alter, modify or change the the shape of the tab on the metal frame.

10. Do not make extra holes on the printed circuit board, modify its shape or change the positions of components to be attached.

11. Do not damage or modify the pattern writing on the printed circuit board.

12. Absolutely do not modify the zebra rubber strip (conductive rubber) or heat seal connector

13. Except for soldering the interface, do not make any alterations or modifications with a soldering iron.

14. Do not drop, bend or twist LCM.

10.2 Storage

1. Store in an ambient temperature of 5 to 45 °C, and in a relative humidity of 40% to 60%. Don't expose to sunlight or fluorescent light.
2. Storage in a clean environment, free from dust, active gas, and solvent.
3. Store in antistatic container.

11. Inspection Standard

This specification is made to be used as the standard acceptance/rejection criteria for Color mobile phone LCM with touch pannel.

11.1 Sample plan and Inspection condition

11.1.1 Sample plan

Sampling plan according to MIL-STD-105E , normal level 2 and based on:

Major defect: AQL 0.65;

Minor defect: AQL 1.5.

11.1.2 Inspection condition

Viewing distance for cosmetic inspection is about 30cm with bare eyes, and under an environment of 20~40W light intensity, all directions for inspecting the sample should be within 45 against perpendicular line.

11.2 Definition of inspection zone in LCD

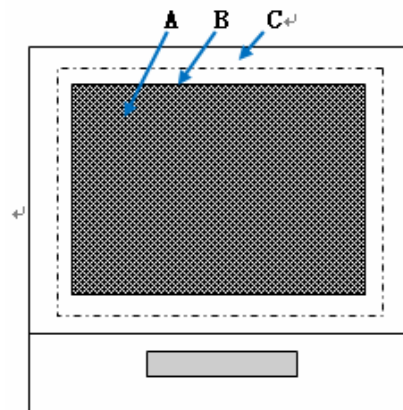

Inspection zones in an LCD

Zone A: character/Digit area;

Zone B: viewing area except Zone A (ZoneA+ZoneB=minimum Viewing area);

Zone C: Outside viewing area (invisible area after assembly in customer's product);

Note: As a general rule, visual defects in Zone C are permissible, when it is no trouble for quality and assembly of customer's product. Defects are classified as major defects and minor defects according to the degree of defectiveness defined herein.

11.3 Major defects and Minor defects

11.3.1 Major defects

A major defect is a defect that is likely to result in failure, or to reduce the usability of the product for its intended purpose.

11.3.1.1 Abnormal operation: modules cannot display normally;

11.3.1.2 Line defect;

11.3.1.3 There is serious distortion or sharp burr on mechanical housing;

11.3.1.4 Glass breakage.

11.3.2 Minor defects:

A minor defect is a defect that is not likely to reduce the usability of the product for its intended purpose.

11.3.2.1 Dot defect:

11.3.2.1.1 Inspection pattern : Full white, full black, red, green and blue screens;

11.3.2.1.2 Criteria :(acceptable);

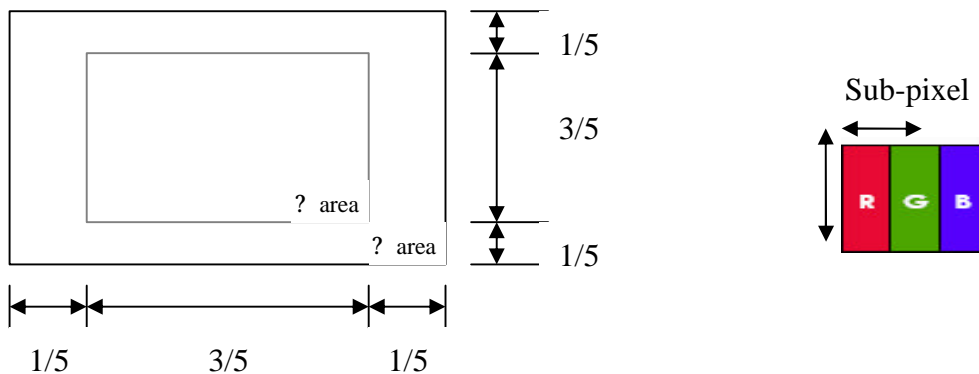

Note: 1. Dot defect is defined as the defective area of the dot area is larger than 50% of the dot area . And the bright dot defect must be visible through 5% ND filter.

2. Except for the allowed numbers of adjacent dots, the distance between dot defects should be more than 3mm apart.

11.3.2.1.3 The definitions of the inner display area and outer display area.

11.4 Inspection standards table:

11.4.1 Major defect

Item No.	Items to be	Inspection Standard	Classification of defects
11.4.1.1	All functional defects	1) No display 2) Display abnormally 3) Missing vertical/horizontal segment 4) Short circuit 5) Back-light no lighting, flickering and abnormal lighting.	Major
11.4.1.2	Missing	Missing component	
11.4.1.3	Outline dimension	Overall outline dimension beyond the drawing is not allowed.	
11.4.1.4	linearity	No more than 1.5%	

11.4.2 Cosmetic Defect (spot defect)

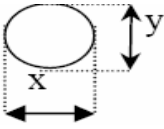
Item No	Itemsto be	Inspection Standard	Classification of defects																							
11.4.2.1	Clear Spots Black and white Spot defect Pinhole, Foreign Particle, polarizer Dirt	For dark/white spot, sizeF is defined as $F = (x + y) / 2$ 	Minor																							
		<table border="1"> <thead> <tr> <th rowspan="2">Zone Size(mm)</th> <th colspan="3">Acceptable Qty</th> </tr> <tr> <th>A</th> <th>B</th> <th>C</th> </tr> </thead> <tbody> <tr> <td>F=0.1</td> <td colspan="3">Ignore</td> </tr> <tr> <td>0.10< F=0.15</td> <td colspan="3">2</td> </tr> <tr> <td>0.15< F=0.20</td> <td colspan="3">1</td> </tr> <tr> <td>F> 0.20</td> <td colspan="3">0</td> </tr> </tbody> </table>	Zone Size(mm)	Acceptable Qty			A	B	C	F=0.1	Ignore			0.10< F=0.15	2			0.15< F=0.20	1			F> 0.20	0			Minor
		Zone Size(mm)		Acceptable Qty																						
			A	B	C																					
		F=0.1	Ignore																							
0.10< F=0.15	2																									
0.15< F=0.20	1																									
F> 0.20	0																									
11.4.2.2	Clear Spots TP Dirt	<table border="1"> <thead> <tr> <th rowspan="2">Zone Size(mm)</th> <th colspan="3">Acceptable Qty</th> </tr> <tr> <th>A</th> <th>B</th> <th>C</th> </tr> </thead> <tbody> <tr> <td>F=0.1</td> <td colspan="3">Ignore</td> </tr> <tr> <td>0.10< F=0.15</td> <td colspan="3">2</td> </tr> <tr> <td>0.15< F=0.25</td> <td colspan="3">1</td> </tr> <tr> <td>F> 0.25</td> <td colspan="3">0</td> </tr> </tbody> </table>	Zone Size(mm)	Acceptable Qty			A	B	C	F=0.1	Ignore			0.10< F=0.15	2			0.15< F=0.25	1			F> 0.25	0			Minor
		Zone Size(mm)		Acceptable Qty																						
			A	B	C																					
		F=0.1	Ignore																							
		0.10< F=0.15	2																							
0.15< F=0.25	1																									
F> 0.25	0																									
11.4.2.3	Dim Spots Circle shaped and dim edged defects	<table border="1"> <thead> <tr> <th rowspan="2">Zone Size(mm)</th> <th colspan="3">Acceptable Qty</th> </tr> <tr> <th>A</th> <th>B</th> <th>C</th> </tr> </thead> <tbody> <tr> <td>F=0.2</td> <td colspan="3">Ignore</td> </tr> <tr> <td>0.20< F=0.4</td> <td colspan="3">2</td> </tr> <tr> <td>0.4< F=0.6</td> <td colspan="3">1</td> </tr> <tr> <td>F> 0.6</td> <td colspan="3">0</td> </tr> </tbody> </table>	Zone Size(mm)	Acceptable Qty			A	B	C	F=0.2	Ignore			0.20< F=0.4	2			0.4< F=0.6	1			F> 0.6	0			Minor
		Zone Size(mm)		Acceptable Qty																						
			A	B	C																					
		F=0.2	Ignore																							
		0.20< F=0.4	2																							
0.4< F=0.6	1																									
F> 0.6	0																									
11.4.2.4	Dot defect	dot =sub-pixel	Minor																							
		<table border="1"> <thead> <tr> <th rowspan="2"></th> <th colspan="2">Acceptable Qty</th> </tr> <tr> <th>I</th> <th>II</th> </tr> </thead> <tbody> <tr> <td>Bright dot</td> <td>0</td> <td>2</td> </tr> <tr> <td>Dark dot</td> <td>1</td> <td>2</td> </tr> </tbody> </table>			Acceptable Qty		I	II	Bright dot	0	2	Dark dot	1	2												
					Acceptable Qty																					
				I	II																					
Bright dot	0	2																								
Dark dot	1	2																								
The distance of two point >5mm																										

11.4.3 Cosmetic Defect (linear defect)

Item No	Items to be	Inspection Standard	Classification of defects																																	
11.4.3.1	Line defect Black line, White line, Foreign material on polarizer	<table border="1"> <thead> <tr> <th colspan="2">Size(mm)</th> <th colspan="3">Acceptable Qty</th> </tr> <tr> <th rowspan="2">L(Length)</th> <th rowspan="2">W(Width)</th> <th colspan="3">zone</th> </tr> <tr> <th>A</th> <th>B</th> <th>C</th> </tr> </thead> <tbody> <tr> <td>Ignore</td> <td>W=0.02</td> <td colspan="3">Ignore</td> </tr> <tr> <td>L=3.0</td> <td>0.02< W=0.03</td> <td colspan="3">2</td> </tr> <tr> <td>L=2.0</td> <td>0.03< W=0.05</td> <td colspan="3">1</td> </tr> <tr> <td></td> <td>W> 0.05</td> <td colspan="3">Define as spot defect</td> </tr> </tbody> </table>	Size(mm)		Acceptable Qty			L(Length)	W(Width)	zone			A	B	C	Ignore	W=0.02	Ignore			L=3.0	0.02< W=0.03	2			L=2.0	0.03< W=0.05	1				W> 0.05	Define as spot defect			Minor
		Size(mm)		Acceptable Qty																																
		L(Length)	W(Width)	zone																																
				A	B	C																														
		Ignore	W=0.02	Ignore																																
		L=3.0	0.02< W=0.03	2																																
L=2.0	0.03< W=0.05	1																																		
	W> 0.05	Define as spot defect																																		

11.4.3.2	Dim line defect Polarizer & BL scratch TP film scratch	<p>If the scratch can be seen after mobile phone cover assembling or in the operating condition, judge by the line defect of 11.4.3.1. If the scratch can be seen only in non-operating condition or some special angle, judge by the following.</p> <table border="1" data-bbox="443 405 1283 728"> <thead> <tr> <th colspan="2">Size(mm)</th> <th colspan="3">Acceptable Qty</th> </tr> <tr> <th rowspan="2">L(Length)</th> <th rowspan="2">W(Width)</th> <th colspan="3">zone</th> </tr> <tr> <th>A</th> <th>B</th> <th>C</th> </tr> </thead> <tbody> <tr> <td>Ignore</td> <td>W=0.02</td> <td colspan="3">Ignore</td> </tr> <tr> <td>L=3.0</td> <td>0.02 < W=0.03</td> <td colspan="3">2</td> </tr> <tr> <td>L=2.0</td> <td>0.03 < W=0.05</td> <td colspan="3">1</td> </tr> <tr> <td></td> <td>W > 0.05</td> <td colspan="3">Define as spot defect</td> </tr> </tbody> </table>	Size(mm)		Acceptable Qty			L(Length)	W(Width)	zone			A	B	C	Ignore	W=0.02	Ignore			L=3.0	0.02 < W=0.03	2			L=2.0	0.03 < W=0.05	1				W > 0.05	Define as spot defect			Minor
Size(mm)		Acceptable Qty																																		
L(Length)	W(Width)	zone																																		
		A	B	C																																
Ignore	W=0.02	Ignore																																		
L=3.0	0.02 < W=0.03	2																																		
L=2.0	0.03 < W=0.05	1																																		
	W > 0.05	Define as spot defect																																		
11.4.3.3	Polarize Air bubble	<p>Air bubbles between glass & polarizer</p> <table border="1" data-bbox="443 770 1283 1072"> <thead> <tr> <th rowspan="2"></th> <th colspan="3">Acceptable Qty</th> </tr> <tr> <th>A</th> <th>B</th> <th>C</th> </tr> </thead> <tbody> <tr> <td>F=0.2</td> <td colspan="3">Ignore</td> </tr> <tr> <td>0.20 < F=0.3</td> <td colspan="3">2</td> </tr> <tr> <td>0.3 < F=0.5</td> <td colspan="3">1</td> </tr> <tr> <td>F > 0.5</td> <td colspan="3">0</td> </tr> </tbody> </table>		Acceptable Qty			A	B	C	F=0.2	Ignore			0.20 < F=0.3	2			0.3 < F=0.5	1			F > 0.5	0			Minor										
	Acceptable Qty																																			
	A	B	C																																	
F=0.2	Ignore																																			
0.20 < F=0.3	2																																			
0.3 < F=0.5	1																																			
F > 0.5	0																																			

11.4.4 Chipping Defect

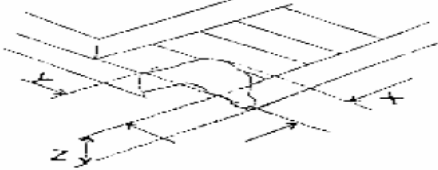
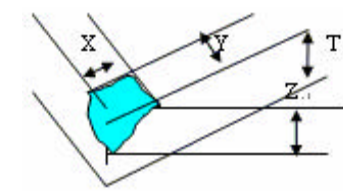
Item No	Items to be	Inspection Standard	Classification of defects												
11.4.4.1	Glass defect	<p>Chips on corner A:LCD Glass defect</p>  <table border="1" data-bbox="925 1366 1284 1444"> <thead> <tr> <th>X</th> <th>Y</th> <th>Z</th> </tr> </thead> <tbody> <tr> <td>=0.2</td> <td>=S</td> <td>Disregard</td> </tr> </tbody> </table> <p>Notes: S=contact pad length Chips on the corner of terminal shall not be allowed to extend into the ITO pad or expose perimeter seal.</p> <p>B:TP Glass defect</p>  <table border="1" data-bbox="925 1646 1284 1724"> <thead> <tr> <th>X</th> <th>Y</th> <th>Z</th> </tr> </thead> <tbody> <tr> <td>=3.0</td> <td>=3.0</td> <td>Disregard</td> </tr> </tbody> </table>	X	Y	Z	=0.2	=S	Disregard	X	Y	Z	=3.0	=3.0	Disregard	Minor
X	Y	Z													
=0.2	=S	Disregard													
X	Y	Z													
=3.0	=3.0	Disregard													

Usual surface cracks

A:LCD Glass defect

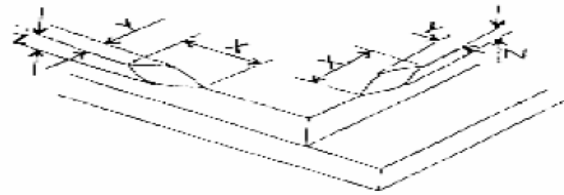

X	Y	Z
≤3.0	<Inner border line of the seal	Disregard

B:TP Glass defect

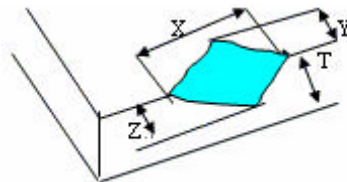

X	Y	Z
≤6.0	≤2.0	Disregard

Crack: Cracks tend to break are not allowed.

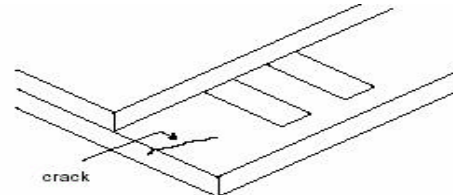

11.4.5 Parts Defect

Item No	Items to be	Inspection Standard	Classification of defects
11.4.5.1	Parts contra position	1、 Not allow IC and FPC/heat-seal lead width is more than 50% beyond lead pattern. 2、 Not allow chip or solder component is off center more than 50% of the pad outline.	Major
11.4.5.2	SMT	According to the <Acceptability of electronic assemblies>IPC-A-610C class 2 standard. Component missing or function defect are Major defect, the others are Minor defect.	Major
11.4.5.3	Backlight elements	1 Illumination source flickers when lit. 2 Spots or scratches that appear when lit must be judged using LCD spot, lines and contamination standards. 3 Backlight doesn't light or color is wrong	Major
11.4.5.4	Soldering	1 No unmelted solder paste may be present on the FPC 2 No cold solder joints, missing solder connections, oxidation or icicle. 3 No short circuits in components on FPC	Major

11. Packing
T.B.D.

X-ON Electronics

Largest Supplier of Electrical and Electronic Components

Click to view similar products for [kentec](#) manufacturer:

Other Similar products are found below :

[K70DWN2-V1-FF](#) [EB-STM32F4DISCOVERY](#) [EB-LM4F120-L35](#)