

Cable-operated mechanism



Features

Cable-operated mechanisms transform linear movements - following pull-out and draw-in of a rope - into rotations. Depending on the requirements, these rotations can be used to drive an incremental or absolute encoder.

The encoder pulses can be evaluated by a digital display, e.g. IVO N214 (please refer to IVO Catalog - Electronic Counters), or by a control unit.

The IVO encoder GI 356 synchro flange is used for the standard version (further types upon request).

There is a choice of three types of ropes, varying in their dimension, material, surface, and physical features:

- stainless steel
- steel with plastic sheath
- para-cord

Order designation

Z 136 Cable-operated mechanism

Technical data

Measuring range	Up to max. 6,000 mm
Preliminary pull-out length	0 mm
Length / revolution	200 mm
Repeating accuracy	Approximately 0.05 mm
Resolution	0.1 mm encoder with 2000 pul./rev.
Proceeding speed	Max. 3000 mm/s
Necessary pull-out force	Min. 5 N
Rope material	Stainless steel
Housing	Aluminium
Color	Black RAL 9005
Weight	Approximately 1050 g

Dimensions and cutout size

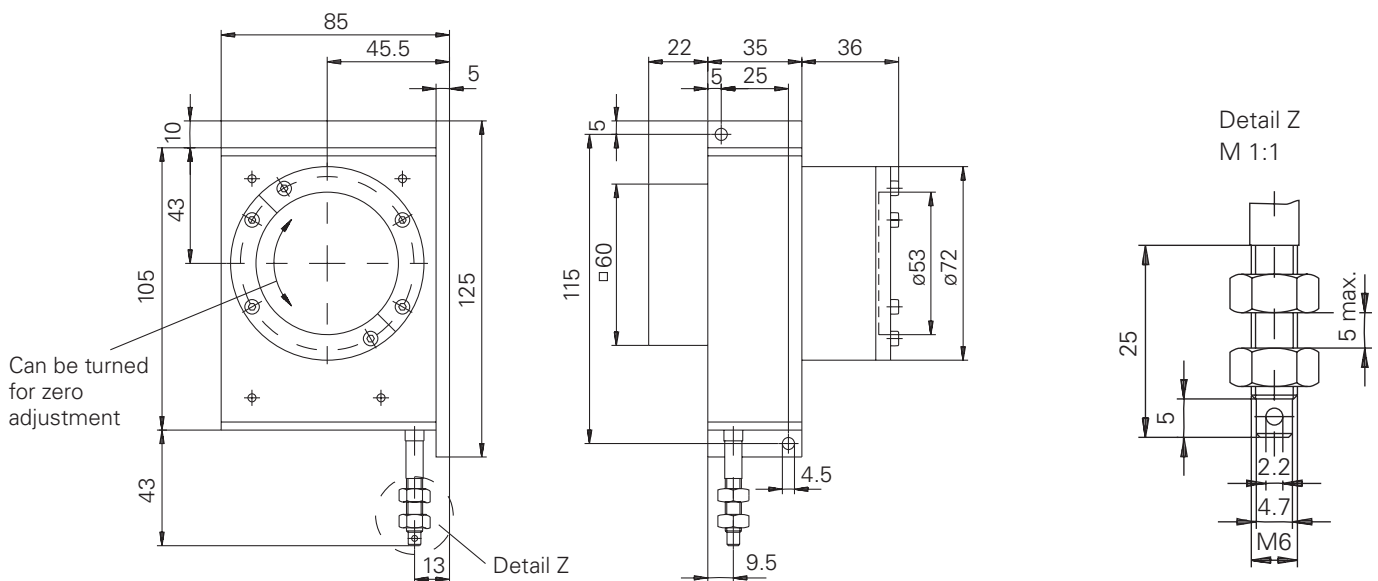

Housing with integrated encoders



Features

The GK401 is a sturdy aluminium casing with integrated encoder and separate bedding. It is possible to integrate absolute encoders as well as incremental encoders. The encoder is driven via a coupling by the shaft of the protective casing and is thus protected against mechanical overstress and shocks on the encoder shaft.

Order designation

- GK401.IXX** Incremental Encoder
- GK401.AXX** Absolute Encoder Singleturn
- GK401.MXX** Absolute Encoder Multiturn
- GK401.PXX** Programmable
Absolute Encoder Multiturn

Technical data (housing)

Protection	IP65, IEC 529 DIN40050
Storage temperature	-20...+85 °C
Operating temperature	-20...+70 °C
Shaft load	Max. Fa = 0.8 kN, Fr = 1.0 kN (100 rev./min)

Only valid for the casing. Other values are applicable to the particular encoder types (refer to encoder catalog).

Dimensions and cutout size

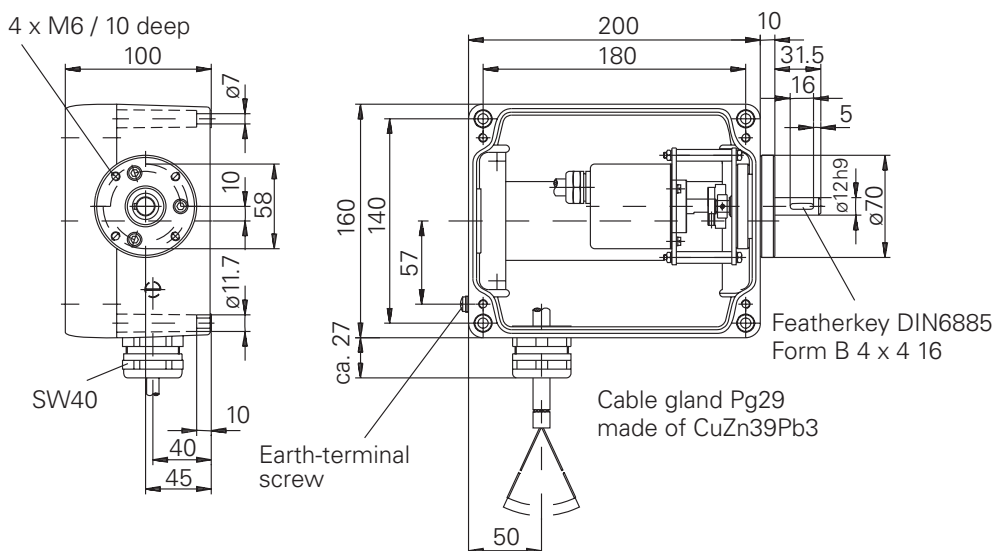

Explosion-protection-housing with built-in encoder



Housing for all types of IVO encoders.
Protection range EEX de II BT6

Ambient conditions

Ambient temperature	-20...+60 °C
Storage temperature	-20...+70 °C
Protection to	
Shaft w/o seal	IP 54
Shaft with seal	IP 65
Relative humidity	Max. 95 %, non-condensing
Interference immunity	EN 50082-2 EN 61000-4 - 2 to 4, Severity grade 3
Emitted interference	EN 50081-2

Order designation

GM480.Zxx
GP480.Zxx

Mechanical data

RPM value	
mechanical	Max. 6,000 RPM
electrical	Max. 3,000 RPM
Starting torque	
w/o seal (IP54)	< 0.010 Nm
with seal (IP65)	< 0.015 Nm
Shaft loading	
axial	< 20 N
radial	< 40 N
Inertia torque	2 x 10 ⁻⁶ kgm ²
Material	
Housing	Plastic
Flange	Aluminium

Dimensions and cutout size

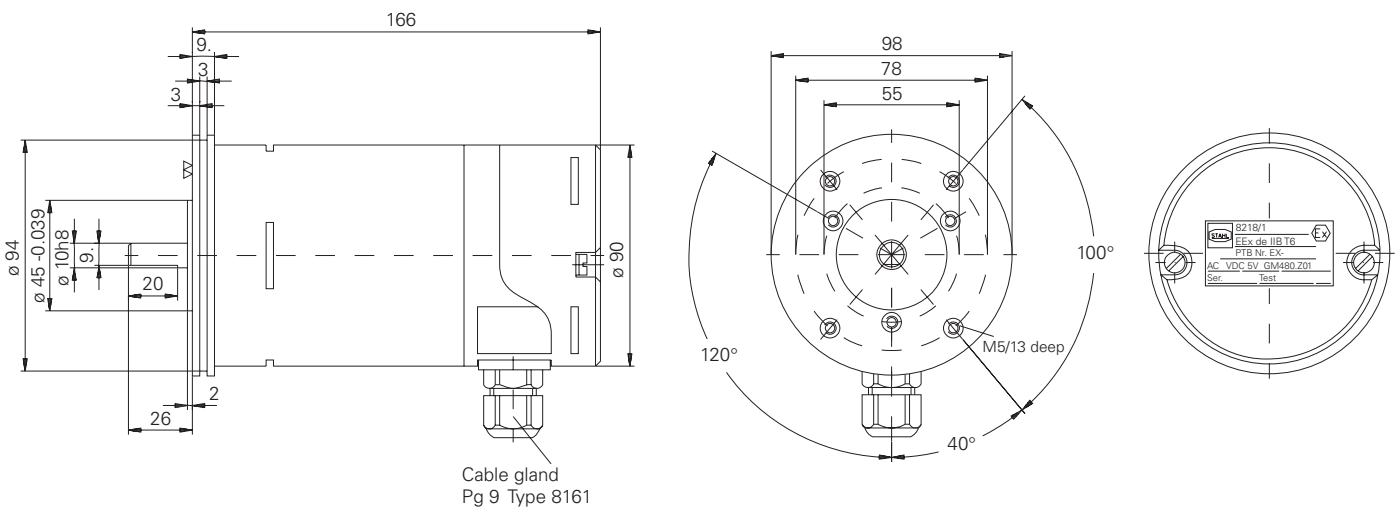

Mounting bell and eccentric fixing



Order designation

Z 119.015

for encoders with synchro flange
(Mounting with Z 119.018)

Dimensions and cutout size

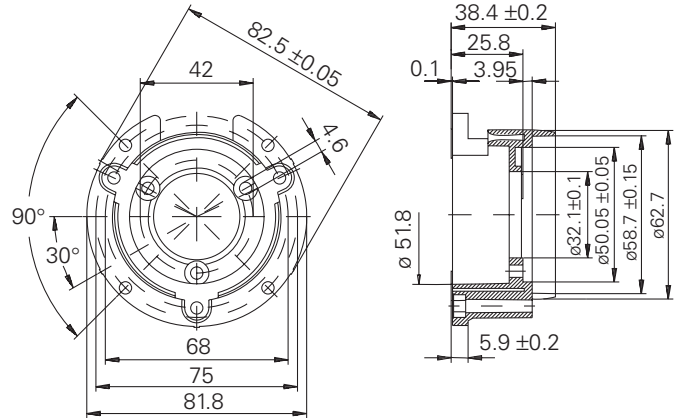

Order designation

Z 119.018

Eccentric fixing with screws and nuts (3 pcs each) for mounting bell Z 119.015

Dimensions and cutout size



Eccentric fixing



Order designation

Z 119.006

Eccentric fixing
(1 piece each)

Dimensions and cutout size

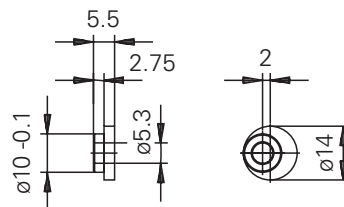

Further bores upon request.

Spring washer coupling

Order designation

Z 121.A01 D1=6, D2=10

Z 121.A02 D1=6, D2=6

Z 121.A03 D1=10, D2=10

Dimensions and cutout size

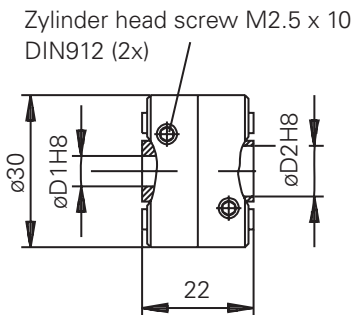

Features

Electrically isolating

Technical data

RPM value	Max. 12,000 RPM
Torque	Max. 40 Ncm
Radial offset	±0.4 mm
Angular error	±2 degree
Axial offset	±0.4 mm
Torsion spring constant	160 degree/Ncm
Inertia torque	25 gcm ²
Weight	Approximately 23 g
Material	
Flange	Zinc diecast
Housing	Plastic

Spring washer coupling

Order designation

Z 121.C01 D1=6, D2=10

Z 121.C02 D1=6, D2=6

Z 121.C03 D1=10, D2=10

Dimensions and cutout size

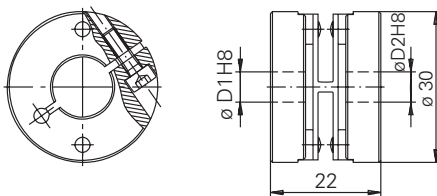

Features

Plug in mounting
Electrically isolating

Technical data

RPM value	Max. 12,000 RPM
Torque	Max. 60 Ncm
Radial offset	±0.3 mm
Angular error	±2.5 degree
Axial offset	±0.4 mm
Material	
Flange	Aluminium
Spring washer	Plastic
Weight	Approximately 26 g

Insert coupling

Order designation

Z 121.B01 D1=6, D2=6

Z 121.B02 D1=5, D2=6

Features

Electrically isolating
Little weight

Dimensions and cutout size

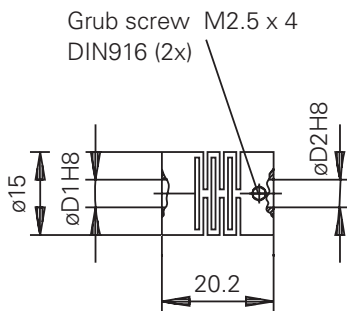

Technical data

RPM value	Max. 10,000 RPM
Torque	Max. 20 Ncm
Radial offset	±0.3 mm
Angular error	±2.5 degree
Axial offset	±0.2 mm
Torsion spring constant	25 degree/Ncm
Inertia torque	1.1 gcm ²
Weight	Approximately 3.5 g
Material	Plastic

Insert coupling

Order designation

Z 121.D01 D1=6, D2=6

Z 121.D02 D1=5, D2=6

Features

Electrically isolating
Metal inset for pin

Dimensions and cutout size

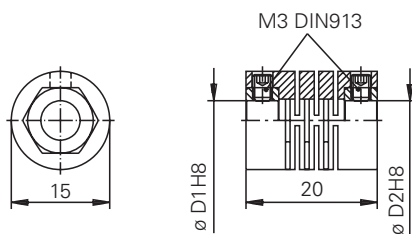

Technical data

RPM value	Max. 12,000 RPM
Torque	Max. 20 Ncm
Radial offset	±0.3 mm
Angular error	±2.5 degree
Axial offset	±0.2 mm
Material	
Body	Plastic
Hexagon socket	Copper-base alloys
Weight	Approximately 7 g

Insert coupling

Order designation

Z 121.06006XX D1=6, D2=6

Z 121.06010XX D1=6, D2=10

Z 121.10010XX D1=10, D2=10

Features

Electrically isolating

Dimensions and cutout size

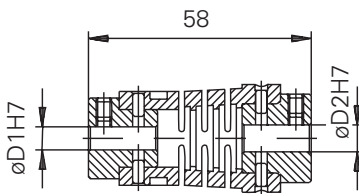

Technical data

RPM value	Max. 3,000 RPM
Torque	Max. 6 Ncm
Radial offset	± 0.15 mm
Angular error	± 2.5 degree
Axial offset	± 0.25 mm
Material	
Coupling	Hostaform
Flange	Aluminium
Weight	Approximately 40 g

Adjustment piece for hollow shaft encoder



Order designation

Z 119.024

Adjustment device for hollow shaft encoder for torque support

Included:

3 Pan-head screws M4 x 10 DIN84

1 Spring washer A4 DIN137

2 Washer

Dimensions and cutout size

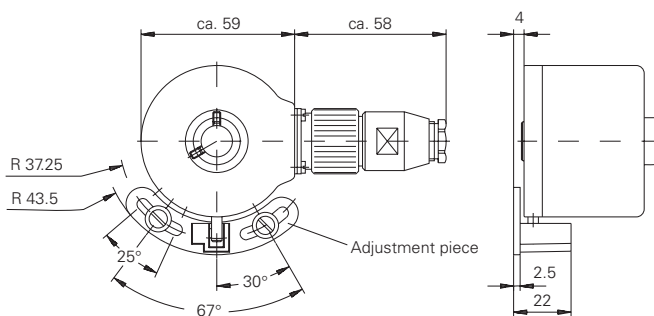

Measuring wheels

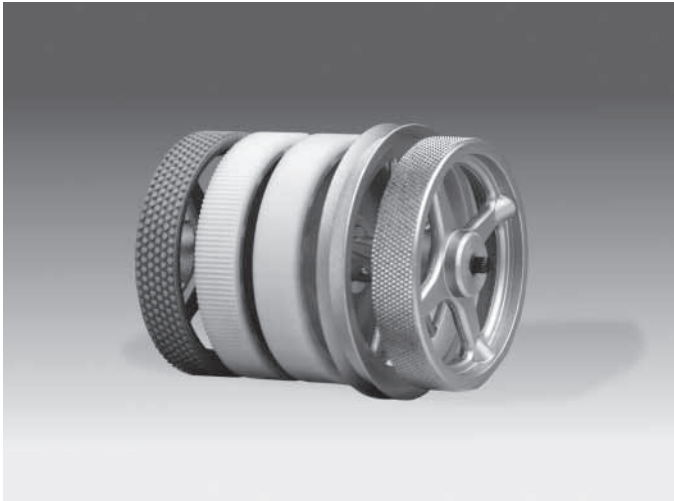

Measuring wheels small

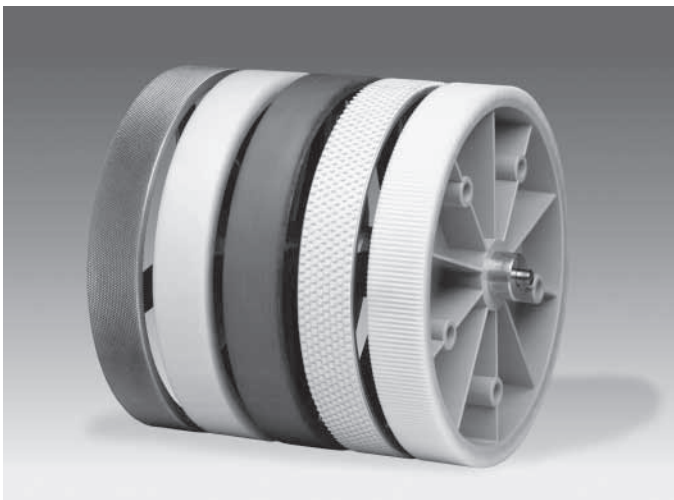

Measuring wheels large

Description

When selecting a measuring wheel, consider the type of goods to be measured before you choose the surface properties or the lining of the measuring wheel. The circumference of the measuring wheel should be chosen according to the available space and size of the counter. The smaller the measuring wheel, the more force will need to be exerted on its circumference and the greater the probability of drift leading to false results. The width of the measuring wheel also influences the measuring result.

Order designations

Measuring wheel with circumference of 20 cm (small)

- 04 Bore 4 mm (Standard)
- 06 Bore 6 mm
- 07 Bore 7 mm

Surface material

- MR211. A Aluminium, axial and circumf. knurl *
- MR234. A Aluminium, flat groove with cross knurl
- MR241. D Plastic, smooth Hytrel
- MR261. A Aluminium, knopped rubber
- MR291. D Plastic, grooved Hytrel

* With bore 7 mm no longer available

Measuring wheel with circumference of 50 cm (large)

- 07 Bore 7 mm (Standard)
- 10 Bore 10 mm (Standard)
- 12 Bore 12 mm

Surface material

- MR512. A Aluminium, axial and circumferential knurl
- MR542. D Plastic, smooth Hytrel
- MR552. A Aluminium, smooth Vulkollan
- MR562. A Aluminium, knopped rubber
- MR592. D Plastic, grooved Hytrel

Measuring wheel with circumference of 1 foot

- 07 Bore 7 mm
- 10 Bore 10 mm

Surface material

- MR751. A Aluminium, smooth rubber

Dimensions and cutout sizes, small measuring wheel

Plastic measuring wheels

Measuring wheel 241, circumf. of 0.2 m with smooth Hytrel
Measuring wheel 291, circumf. of 0.2 m with grooved Hytrel

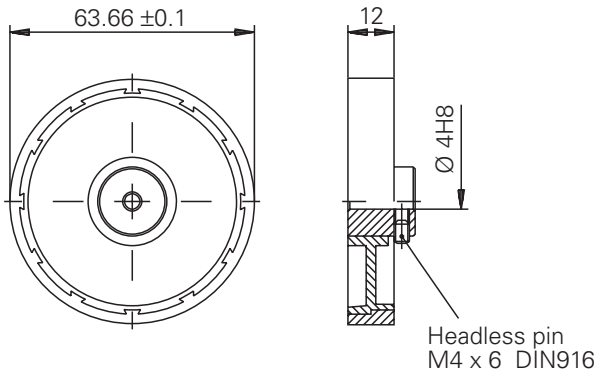

Dimensions and cutout sizes, large measuring wheel

Plastic measuring wheels

Measuring wheel 542, circumf. of 0.5 m with smooth Hytrel
Measuring wheel 592, circumf. of 0.5 m with grooved Hytrel

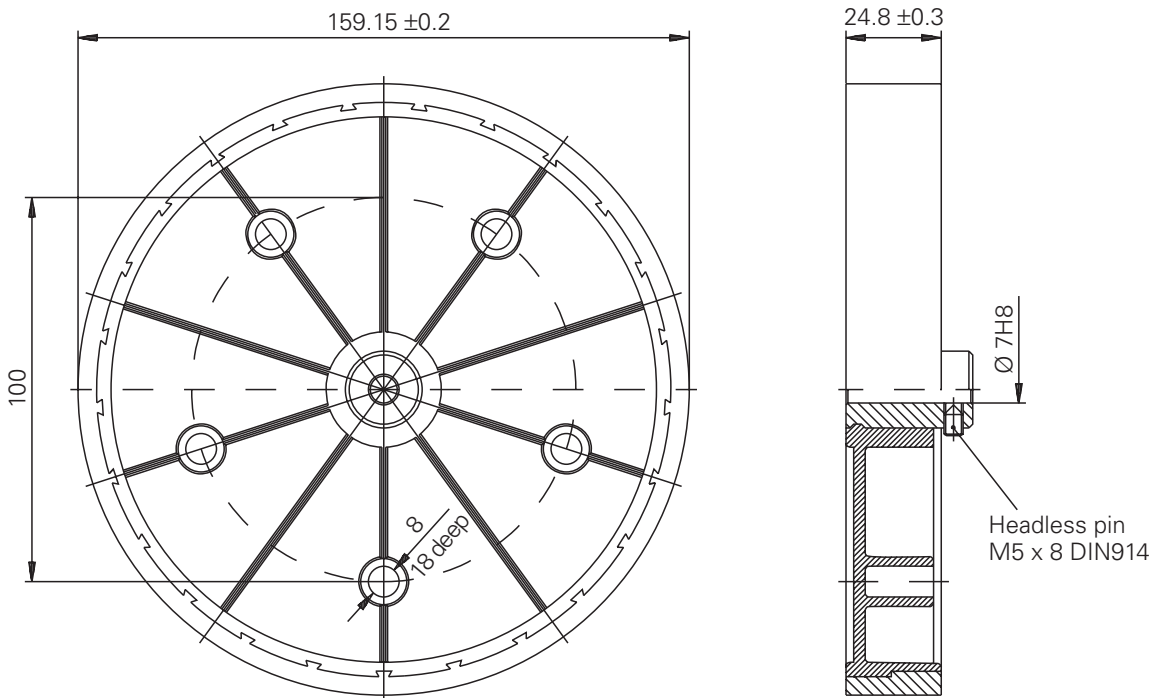

Measuring accuracy

The measuring accuracy of a meter counter with measuring wheel depends on the following features:

- Type of products to be measured
- Angle of contact
- Torque of counter or encoder
- Feeding speed of products
- Tensile stress of products to be measured
- Surface roughness
- Contact pressure of products to be measured against measuring wheel
- Suppleness of products to be measured
- Diametrical tolerance of measuring wheel

Suitable products to be measured

Recommended liming

Grooved Hytrel

Smooth Hytrel

Axial a. circumf. knurl

Knopped rubber

Smooth Vulkollan

Suitable material

Plastic, Painted material, Paper, Cardboard, Wood, Metal, Textile

Plastic, Painted material, Paper, Cardboard, Wood, Metal, Textile

Cardboard, Wood, (Textile)

Textile

Plastic, Painted material, Paper, Cardboard, Wood, Metal, Wire

X-ON Electronics

Largest Supplier of Electrical and Electronic Components

Click to view similar products for [ivo](#) manufacturer:

Other Similar products are found below :

[IVO](#)