

Trimmer Potentiometers



Lead Sealed Type Single-turn PV32 Series

■ Features

1. 1/4 " Round / Single-turn / Cermet / Sealed
2. Units can be pre-adjusted at clockwise, counter-clockwise or standard 50 % position
3. Flammability: UL 94V-0
4. RoHS compliant*
5. For trimmer applications/processing guidelines, [click here](#)

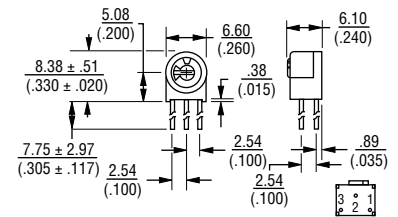
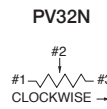
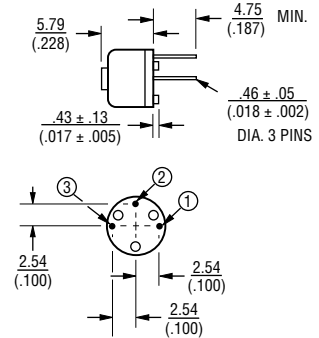
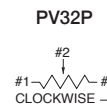
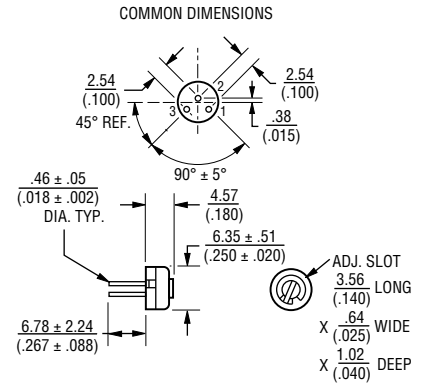
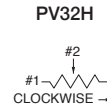

DIMENSIONS: $\frac{\text{MM}}{\text{(INCHES)}}$
TOLERANCES: $\pm \frac{0.25}{(.010)}$ EXCEPT WHERE NOTED



WARNING Cancer and Reproductive Harm
www.P65Warnings.ca.gov

*RoHS Directive 2002/95/EC Jan. 27, 2003 including annex and RoHS Recast 2011/65/EU June 8, 2011. Specifications are subject to change without notice. Users should verify actual device performance in their specific applications. The products described herein and this document are subject to specific legal disclaimers as set forth on the last page of this document, and at www.bourns.com/docs/legal/disclaimer.pdf.

Top Adjustment

Part Number	Power Rating (W)	Number of Turns (Effective Rotation Angle)	Mechanical Rotation Angle	Total Resistance Value	TCR (ppm/°C)
PV32H100A0xB00	0.5 (70 °C)	1 (240 ° ±5°)	260 ° ±5 °	10 ohm ±20 %	±100
PV32H200A0xB00	0.5 (70 °C)	1 (240 ° ±5°)	260 ° ±5 °	20 ohm ±20 %	±100
PV32H500A0xB00	0.5 (70 °C)	1 (240 ° ±5°)	260 ° ±5 °	50 ohm ±20 %	±100
PV32H101A0xB00	0.5 (70 °C)	1 (240 ° ±5°)	260 ° ±5 °	100 ohm ±20 %	±100
PV32H201A0xB00	0.5 (70 °C)	1 (240 ° ±5°)	260 ° ±5 °	200 ohm ±20 %	±100
PV32H251A0xB00	0.5 (70 °C)	1 (240 ° ±5°)	260 ° ±5 °	250 ohm ±20 %	±100
PV32H501A0xB00	0.5 (70 °C)	1 (240 ° ±5°)	260 ° ±5 °	500 ohm ±20 %	±100
PV32H102A0xB00	0.5 (70 °C)	1 (240 ° ±5°)	260 ° ±5 °	1k ohm ±20 %	±100
PV32H202A0xB00	0.5 (70 °C)	1 (240 ° ±5°)	260 ° ±5 °	2k ohm ±20 %	±100
PV32H252A0xB00	0.5 (70 °C)	1 (240 ° ±5°)	260 ° ±5 °	2.5k ohm ±20 %	±100
PV32H502A0xB00	0.5 (70 °C)	1 (240 ° ±5°)	260 ° ±5 °	5k ohm ±20 %	±100
PV32H103A0xB00	0.5 (70 °C)	1 (240 ° ±5°)	260 ° ±5 °	10k ohm ±20 %	±100
PV32H203A0xB00	0.5 (70 °C)	1 (240 ° ±5°)	260 ° ±5 °	20k ohm ±20 %	±100
PV32H253A0xB00	0.5 (70 °C)	1 (240 ° ±5°)	260 ° ±5 °	25k ohm ±20 %	±100
PV32H503A0xB00	0.5 (70 °C)	1 (240 ° ±5°)	260 ° ±5 °	50k ohm ±20 %	±100
PV32H104A0xB00	0.5 (70 °C)	1 (240 ° ±5°)	260 ° ±5 °	100k ohm ±20 %	±100
PV32H204A0xB00	0.5 (70 °C)	1 (240 ° ±5°)	260 ° ±5 °	200k ohm ±20 %	±100
PV32H254A0xB00	0.5 (70 °C)	1 (240 ° ±5°)	260 ° ±5 °	250k ohm ±20 %	±100
PV32H504A0xB00	0.5 (70 °C)	1 (240 ° ±5°)	260 ° ±5 °	500k ohm ±20 %	±100
PV32H105A0xB00	0.5 (70 °C)	1 (240 ° ±5°)	260 ° ±5 °	1M ohm ±20 %	±100

PV32P100A0xB00	0.5 (70 °C)	1 (240 ° ±5°)	260 ° ±5 °	10 ohm ±20 %	±100
PV32P200A0xB00	0.5 (70 °C)	1 (240 ° ±5°)	260 ° ±5 °	20 ohm ±20 %	±100
PV32P500A0xB00	0.5 (70 °C)	1 (240 ° ±5°)	260 ° ±5 °	50 ohm ±20 %	±100
PV32P101A0xB00	0.5 (70 °C)	1 (240 ° ±5°)	260 ° ±5 °	100 ohm ±20 %	±100
PV32P201A0xB00	0.5 (70 °C)	1 (240 ° ±5°)	260 ° ±5 °	200 ohm ±20 %	±100
PV32P251A0xB00	0.5 (70 °C)	1 (240 ° ±5°)	260 ° ±5 °	250 ohm ±20 %	±100
PV32P501A0xB00	0.5 (70 °C)	1 (240 ° ±5°)	260 ° ±5 °	500 ohm ±20 %	±100
PV32P102A0xB00	0.5 (70 °C)	1 (240 ° ±5°)	260 ° ±5 °	1k ohm ±20 %	±100
PV32P202A0xB00	0.5 (70 °C)	1 (240 ° ±5°)	260 ° ±5 °	2k ohm ±20 %	±100
PV32P252A0xB00	0.5 (70 °C)	1 (240 ° ±5°)	260 ° ±5 °	2.5k ohm ±20 %	±100
PV32P502A0xB00	0.5 (70 °C)	1 (240 ° ±5°)	260 ° ±5 °	5k ohm ±20 %	±100
PV32P103A0xB00	0.5 (70 °C)	1 (240 ° ±5°)	260 ° ±5 °	10k ohm ±20 %	±100
PV32P203A0xB00	0.5 (70 °C)	1 (240 ° ±5°)	260 ° ±5 °	20k ohm ±20 %	±100
PV32P253A0xB00	0.5 (70 °C)	1 (240 ° ±5°)	260 ° ±5 °	25k ohm ±20 %	±100
PV32P503A0xB00	0.5 (70 °C)	1 (240 ° ±5°)	260 ° ±5 °	50k ohm ±20 %	±100
PV32P104A0xB00	0.5 (70 °C)	1 (240 ° ±5°)	260 ° ±5 °	100k ohm ±20 %	±100
PV32P204A0xB00	0.5 (70 °C)	1 (240 ° ±5°)	260 ° ±5 °	200k ohm ±20 %	±100
PV32P254A0xB00	0.5 (70 °C)	1 (240 ° ±5°)	260 ° ±5 °	250k ohm ±20 %	±100
PV32P504A0xB00	0.5 (70 °C)	1 (240 ° ±5°)	260 ° ±5 °	500k ohm ±20 %	±100
PV32P105A0xB00	0.5 (70 °C)	1 (240 ° ±5°)	260 ° ±5 °	1M ohm ±20 %	±100

Operating Temperature Range: -55 to 125 °C

Soldering Method: Wave (Single and Dual)

BOURNS®

Specifications are subject to change without notice.

Users should verify actual device performance in their specific applications.

The products described herein and this document are subject to specific legal disclaimers as set forth on the last page of this document, and at www.bourns.com/docs/legal/disclaimer.pdf.

Side Adjustment

Part Number	Power Rating (W)	Number of Turns (Effective Rotation Angle)	Mechanical Rotation Angle	Total Resistance Value	TCR (ppm/°C)
PV32N100A0xB00	0.5 (70 °C)	1 (240 ° ±5°)	260 ° ±5 °	10 ohm ±20 %	±100
PV32N200A0xB00	0.5 (70 °C)	1 (240 ° ±5°)	260 ° ±5 °	20 ohm ±20 %	±100
PV32N500A0xB00	0.5 (70 °C)	1 (240 ° ±5°)	260 ° ±5 °	50 ohm ±20 %	±100
PV32N101A0xB00	0.5 (70 °C)	1 (240 ° ±5°)	260 ° ±5 °	100 ohm ±20 %	±100
PV32N201A0xB00	0.5 (70 °C)	1 (240 ° ±5°)	260 ° ±5 °	200 ohm ±20 %	±100
PV32N251A0xB00	0.5 (70 °C)	1 (240 ° ±5°)	260 ° ±5 °	250 ohm ±20 %	±100
PV32N501A0xB00	0.5 (70 °C)	1 (240 ° ±5°)	260 ° ±5 °	500 ohm ±20 %	±100
PV32N102A0xB00	0.5 (70 °C)	1 (240 ° ±5°)	260 ° ±5 °	1k ohm ±20 %	±100
PV32N202A0xB00	0.5 (70 °C)	1 (240 ° ±5°)	260 ° ±5 °	2k ohm ±20 %	±100
PV32N252A0xB00	0.5 (70 °C)	1 (240 ° ±5°)	260 ° ±5 °	2.5k ohm ±20 %	±100
PV32N502A0xB00	0.5 (70 °C)	1 (240 ° ±5°)	260 ° ±5 °	5k ohm ±20 %	±100
PV32N103A0xB00	0.5 (70 °C)	1 (240 ° ±5°)	260 ° ±5 °	10k ohm ±20 %	±100
PV32N203A0xB00	0.5 (70 °C)	1 (240 ° ±5°)	260 ° ±5 °	20k ohm ±20 %	±100
PV32N253A0xB00	0.5 (70 °C)	1 (240 ° ±5°)	260 ° ±5 °	25k ohm ±20 %	±100
PV32N503A0xB00	0.5 (70 °C)	1 (240 ° ±5°)	260 ° ±5 °	50k ohm ±20 %	±100
PV32N104A0xB00	0.5 (70 °C)	1 (240 ° ±5°)	260 ° ±5 °	100k ohm ±20 %	±100
PV32N204A0xB00	0.5 (70 °C)	1 (240 ° ±5°)	260 ° ±5 °	200k ohm ±20 %	±100
PV32N254A0xB00	0.5 (70 °C)	1 (240 ° ±5°)	260 ° ±5 °	250k ohm ±20 %	±100
PV32N504A0xB00	0.5 (70 °C)	1 (240 ° ±5°)	260 ° ±5 °	500k ohm ±20 %	±100
PV32N105A0xB00	0.5 (70 °C)	1 (240 ° ±5°)	260 ° ±5 °	1M ohm ±20 %	±100

Operating Temperature Range: -55 to 125 °C

Soldering Method: Wave (Single and Dual)

BOURNS®

Specifications are subject to change without notice.

Users should verify actual device performance in their specific applications.

The products described herein and this document are subject to specific legal disclaimers as set forth on the last page of this document, and at www.bourns.com/docs/legal/disclaimer.pdf.

Standard Mounting Holes

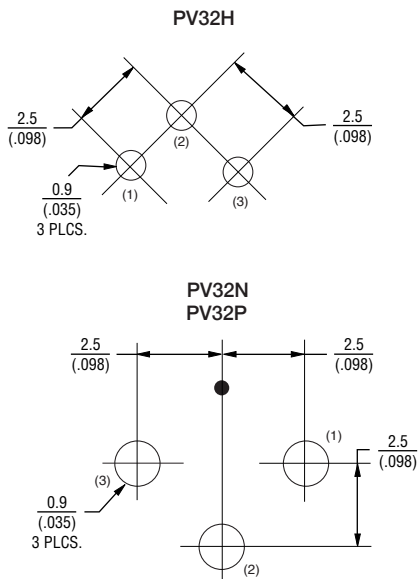

DIMENSIONS: $\frac{\text{MM}}{\text{(INCHES)}}$
TOLERANCES: $\pm \frac{0.1}{(.004)}$
EXCEPT WHERE NOTED

Typical Part Marking

3-Digit Date Code and Manufacturing Code

- First digit indicates year of manufacture;
- Last two digits indicate week of manufacture;
- 4th digit is suffix for manufacturing location:
C = Costa Rica

Example:

604C = Manufactured in 2016, week 4,
Costa Rica

Resistance Code

- Resistance code marking as shown in the *Part Numbering Resistance Table*.

Part Numbering

Product ID **PV 32 P 103 A01 B00**

PV = Trimming Potentiometer

Series 32 = Lead Sealed 6 mm Round Single-turn

Adjustment Direction/Lead Type

H = Top, Triangle
P = Top, Triangle
N = Side, Triangle

Total Resistance _____
Expressed by three figures.
The first and second figures are significant digits;
the third figure expresses the number of zeros
that follow.

Resistance (Ohms)	Resistance Code
10	100
20	200
50	500
100	101
200	201
250	251
500	501
1,000	102
2,000	202
2,500	252
5,000	502
10,000	103
20,000	203
25,000	253
50,000	503
100,000	104
200,000	204
250,000	254
500,000	504
1,000,000	105

Popular distribution resistance values listed in boldface. Special resistances available.

Individual Specification _____
A01 = Standard Type
A02 = 10 % Resistance Tolerance

Packaging _____
B00 = Tube (50 pcs. per tube)

BOURNS®

Legal Disclaimer Notice

BOURNS®

This legal disclaimer applies to purchasers and users of Bourns® products manufactured by or on behalf of Bourns, Inc. and its affiliates (collectively, "Bourns").

Unless otherwise expressly indicated in writing, Bourns® products and data sheets relating thereto are subject to change without notice. Users should check for and obtain the latest relevant information and verify that such information is current and complete before placing orders for Bourns® products.

The characteristics and parameters of a Bourns® product set forth in its data sheet are based on laboratory conditions, and statements regarding the suitability of products for certain types of applications are based on Bourns' knowledge of typical requirements in generic applications. The characteristics and parameters of a Bourns® product in a user application may vary from the data sheet characteristics and parameters due to (i) the combination of the Bourns® product with other components in the user's application, or (ii) the environment of the user application itself. The characteristics and parameters of a Bourns® product also can and do vary in different applications and actual performance may vary over time. Users should always verify the actual performance of the Bourns® product in their specific devices and applications, and make their own independent judgments regarding the amount of additional test margin to design into their device or application to compensate for differences between laboratory and real world conditions.

Unless Bourns has explicitly designated an individual Bourns® product as meeting the requirements of a particular industry standard (e.g., ISO/TS 16949) or a particular qualification (e.g., UL listed or recognized), Bourns is not responsible for any failure of an individual Bourns® product to meet the requirements of such industry standard or particular qualification. Users of Bourns® products are responsible for ensuring compliance with safety-related requirements and standards applicable to their devices or applications.

Bourns® products are not recommended, authorized or intended for use in nuclear, lifesaving, life-critical or life-sustaining applications, nor in any other applications where failure or malfunction may result in personal injury, death, or severe property or environmental damage. Unless expressly and specifically approved in writing by two authorized Bourns representatives on a case-by-case basis, use of any Bourns® products in such unauthorized applications might not be safe and thus is at the user's sole risk. Life-critical applications include devices identified by the U.S. Food and Drug Administration as Class III devices and generally equivalent classifications outside of the United States.

Bourns expressly identifies those Bourns® standard products that are suitable for use in automotive applications on such products' data sheets in the section entitled "Applications." Unless expressly and specifically approved in writing by two authorized Bourns representatives on a case-by-case basis, use of any other Bourns® standard products in an automotive application might not be safe and thus is not recommended, authorized or intended and is at the user's sole risk. If Bourns expressly identifies a sub-category of automotive application in the data sheet for its standard products (such as infotainment or lighting), such identification means that Bourns has reviewed its standard product and has determined that if such Bourns® standard product is considered for potential use in automotive applications, it should only be used in such sub-category of automotive applications. Any reference to Bourns® standard product in the data sheet as compliant with the AEC-Q standard or "automotive grade" does not by itself mean that Bourns has approved such product for use in an automotive application.

Bourns® standard products are not tested to comply with United States Federal Aviation Administration standards generally or any other generally equivalent governmental organization standard applicable to products designed or manufactured for use in aircraft or space applications. Bourns expressly identifies Bourns® standard products that are suitable for use in aircraft or space applications on such products' data sheets in the section entitled "Applications." Unless expressly and specifically approved in writing by two authorized Bourns representatives on a case-by-case basis, use of any other Bourns® standard product in an aircraft or space application might not be safe and thus is not recommended, authorized or intended and is at the user's sole risk.

The use and level of testing applicable to Bourns® custom products shall be negotiated on a case-by-case basis by Bourns and the user for which such Bourns® custom products are specially designed. Absent a written agreement between Bourns and the user regarding the use and level of such testing, the above provisions applicable to Bourns® standard products shall also apply to such Bourns® custom products.

Users shall not sell, transfer, export or re-export any Bourns® products or technology for use in activities which involve the design, development, production, use or stockpiling of nuclear, chemical or biological weapons or missiles, nor shall they use Bourns® products or technology in any facility which engages in activities relating to such devices. The foregoing restrictions apply to all uses and applications that violate national or international prohibitions, including embargos or international regulations. Further, Bourns® products and Bourns technology and technical data may not under any circumstance be exported or re-exported to countries subject to international sanctions or embargoes. Bourns® products may not, without prior authorization from Bourns and/or the U.S. Government, be resold, transferred, or re-exported to any party not eligible to receive U.S. commodities, software, and technical data.

To the maximum extent permitted by applicable law, Bourns disclaims (i) any and all liability for special, punitive, consequential, incidental or indirect damages or lost revenues or lost profits, and (ii) any and all implied warranties, including implied warranties of fitness for particular purpose, non-infringement and merchantability.

For your convenience, copies of this Legal Disclaimer Notice with German, Spanish, Japanese, Traditional Chinese and Simplified Chinese bilingual versions are available at:

Web Page: <http://www.bourns.com/legal/disclaimers-terms-and-policies>

PDF: <http://www.bourns.com/docs/Legal/disclaimer.pdf>

X-ON Electronics

Largest Supplier of Electrical and Electronic Components

Click to view similar products for [Trimmer Resistors - Through Hole](#) category:

Click to view products by [Bourns](#) manufacturer:

Other Similar products are found below :

[56PR250K](#) [M63M102KB30T607](#) [M63M103KB40](#) [M63M501KB40](#) [M63P102KB30T607](#) [M63P105KB30T607](#) [M63P202KB40](#)
[M63P203KB30T607](#) [M63P203KB40](#) [M63P205KB30T607](#) [M63P501KB40](#) [M63P502KB40](#) [M63S102KB40](#) [M63S103KB40](#) [M63X101KB40](#)
[M63X103KB40](#) [M63X104KB40](#) [M63X501KB40](#) [M63X503KB40](#) [M70Y102KB25](#) [76PR500K](#) [79PR5K](#) [P8PY103KB25](#) [CT6P-103](#)
[M63M102KB40](#) [M63M104KB40](#) [M63M502KB40](#) [M63P102KB40](#) [M63P103KB30T640](#) [M63P103KB40](#) [M63P104KB30T607](#)
[M63P104KB40](#) [M63P204KB40](#) [M63P504KB40](#) [M63S203KB40](#) [M63S502KB40](#) [M63X105KB40](#) [M63X502KB40](#) [M70Y203KB25](#)
[M70Y502KB25](#) [404806505008](#) [388N-100](#) [409HA102M](#) [4270W105K](#) [56PR2MEG](#) [82PR2KLFTB](#) [416MA504P](#) [SK 104 25,4 STC TO 220](#)
[9702-2SL-1](#) [M64X500KB40](#)