

Product	Contacts 8(4 + 3+PE): male cable connector, cable outlet 7-13mm/12-17mm, rated voltage: 60 V Signal, 400 V Power
Area	Bajonett HEC Power Series 696
Article number	99 6501 000 08

Illustration	Scale drawing	Contact Arrangement																											
		<table border="1" style="margin-left: auto; margin-right: auto;"> <thead> <tr> <th></th> <th>X</th> <th>Y</th> </tr> </thead> <tbody> <tr><td>1</td><td>-3,68</td><td>5,50</td></tr> <tr><td>2</td><td>0</td><td>-6,60</td></tr> <tr><td>3</td><td>3,68</td><td>5,50</td></tr> <tr><td>4</td><td>-7,25</td><td>0,20</td></tr> <tr><td>5</td><td>-5,90</td><td>-4,20</td></tr> <tr><td>6</td><td>5,90</td><td>-4,20</td></tr> <tr><td>7</td><td>7,25</td><td>0,20</td></tr> <tr><td>PE</td><td>0</td><td>0</td></tr> </tbody> </table> <p style="text-align: right; margin-right: 20px;"> 1, 2, 3, ⊕ Ø 2,5 mm 4, 5, 6, 7 Ø 1,6 mm </p>		X	Y	1	-3,68	5,50	2	0	-6,60	3	3,68	5,50	4	-7,25	0,20	5	-5,90	-4,20	6	5,90	-4,20	7	7,25	0,20	PE	0	0
	X	Y																											
1	-3,68	5,50																											
2	0	-6,60																											
3	3,68	5,50																											
4	-7,25	0,20																											
5	-5,90	-4,20																											
6	5,90	-4,20																											
7	7,25	0,20																											
PE	0	0																											

You can find the item description and assembly instruction on the next page.

Technical data

<h3 style="color: #f4a460;">Common values</h3> <table border="0"> <tr><td>Connector Design</td><td>Cable plug connector</td></tr> <tr><td>Connector locking system</td><td>Bayonet</td></tr> <tr><td>Termination</td><td>Crimp</td></tr> <tr><td>Wire gauge (mm)</td><td>0,14 - 2,5mm²</td></tr> <tr><td>Wire gauge (AWG)</td><td>14 - 26</td></tr> <tr><td>Cable outlet</td><td>7-13 mm, 12-17 mm</td></tr> <tr><td>Upper temperature</td><td>100 °C</td></tr> <tr><td>Lower temperature</td><td>-40 °C</td></tr> </table>		Connector Design	Cable plug connector	Connector locking system	Bayonet	Termination	Crimp	Wire gauge (mm)	0,14 - 2,5mm ²	Wire gauge (AWG)	14 - 26	Cable outlet	7-13 mm, 12-17 mm	Upper temperature	100 °C	Lower temperature	-40 °C	<h3 style="color: #f4a460;">Electrical values</h3> <table border="0"> <tr><td>Rated impulse voltage</td><td>5000 V</td></tr> <tr><td>Pollution degree</td><td>3</td></tr> <tr><td>Overvoltage category</td><td>III</td></tr> <tr><td>Material group</td><td>I,II</td></tr> <tr><td>Rated current (40°C)</td><td>3 A Signal, 25 A Power (20 A UL)</td></tr> <tr><td>Volume resistivity</td><td>≤ 8 mΩ</td></tr> <tr><td>Degree of protection</td><td>IP68/IP69K</td></tr> <tr><td>Mechanical operation</td><td>> 1000 mating cycles</td></tr> </table>		Rated impulse voltage	5000 V	Pollution degree	3	Overvoltage category	III	Material group	I,II	Rated current (40°C)	3 A Signal, 25 A Power (20 A UL)	Volume resistivity	≤ 8 mΩ	Degree of protection	IP68/IP69K	Mechanical operation	> 1000 mating cycles
Connector Design	Cable plug connector																																		
Connector locking system	Bayonet																																		
Termination	Crimp																																		
Wire gauge (mm)	0,14 - 2,5mm ²																																		
Wire gauge (AWG)	14 - 26																																		
Cable outlet	7-13 mm, 12-17 mm																																		
Upper temperature	100 °C																																		
Lower temperature	-40 °C																																		
Rated impulse voltage	5000 V																																		
Pollution degree	3																																		
Overvoltage category	III																																		
Material group	I,II																																		
Rated current (40°C)	3 A Signal, 25 A Power (20 A UL)																																		
Volume resistivity	≤ 8 mΩ																																		
Degree of protection	IP68/IP69K																																		
Mechanical operation	> 1000 mating cycles																																		
<h3 style="color: #f4a460;">Material</h3> <table border="0"> <tr><td>Material of contact</td><td>-</td></tr> <tr><td>Contact plating</td><td>Ag (Silver)</td></tr> <tr><td>Material of contact body</td><td>PA</td></tr> <tr><td>Material of housing</td><td>PA</td></tr> </table>		Material of contact	-	Contact plating	Ag (Silver)	Material of contact body	PA	Material of housing	PA																										
Material of contact	-																																		
Contact plating	Ag (Silver)																																		
Material of contact body	PA																																		
Material of housing	PA																																		

Product **Contacts 8(4 + 3+PE): male cable connector, cable outlet 7-13mm/12-17mm, rated voltage: 60 V Signal, 400 V Power**

Area **Bajonett HEC Power Series 696**

Article number **99 6501 000 08**

Item description

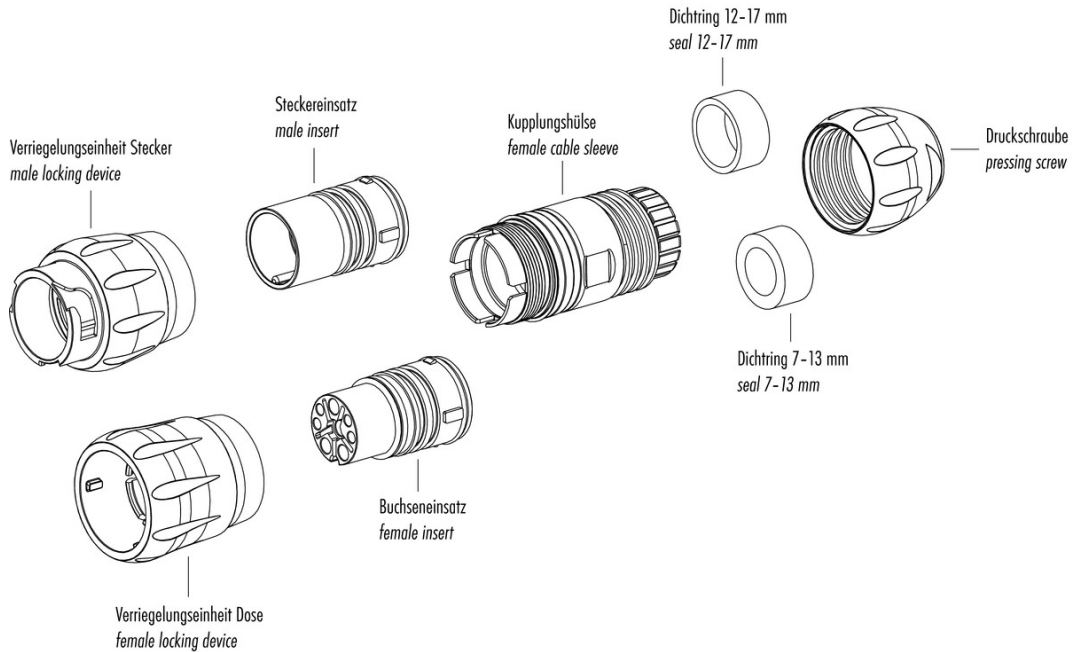

Installation instructions / Mounting cutout

1. Abmonteln auf Länge 1 = 45mm. Ummantelung abstreifen.
2. Druckschraube, Dichtung und Kupplungshülse auf Kabel aufstecken.
3. Litzen isolieren l = 7mm.
4. Kontakte anzuprimen.*
5. Angelegte Kontakte in den Kontaktkörper bis zum Einrasten eindrücken und diesen in die Kupplungshülse bis auf Anschlag schieben.
6. Verriegelungseinheit am Gewinde der Kupplungshülse aufsetzen und mit leichtem Druck in Pfeilrichtung festschrauben. (empfohlenes Drehmoment 80ckNm)
7. Den Dichtung in den Klemmkorb bis auf Anschlag schieben und mit der Druckschraube festschrauben. (empfohlenes Drehmoment 220-250ckNm)

Lösen der Kontakte:
Da die Kontakte schwimmend gelagert sind, lässt sich das Lösewerkzeug mit leichten Pendelbewegungen bis auf Anschlag einführen. Danach zum Lösen den Ausdrückknopf betätigen.

* Crimpzange Bestell-Nr. 66 0003 001

Lösewerkzeug Kontakt Ø 1,6 mm 66 0004 001
Ø 2,5 mm 66 0011 001

1. Strip to 45mm length and take off cable jacket.
2. Bend pressing screw, pinch ring, seal and distance sleeve to cable.
3. Strip insulation of the single wires (length 7mm).
4. Crimp contacts to single wires.*
5. Press crimped contacts into contact carrier until they snap into place. Then push the carrier into the connector sleeve to block.
6. Put locking unit to the thread of the connector sleeve and screw it with slight pressure towards the direction marked with an arrow until it is tight. (recommended torque 80 cNm)
7. Push sealing ring into the pinch ring to block and fix both by screwing the pressing screw towards the connector sleeve. (recommended torque 220-250 cNm)

Extracting the contacts:
As the contacts are full floating the extraction tool can be inserted with slight pendular movements to block. Afterwards press the extraction button.

* Crimping tool ordering number 66 0003 001

Extraction tool for contacts Ø 1,6 mm 66 0004 001
Ø 2,5 mm 66 0011 001

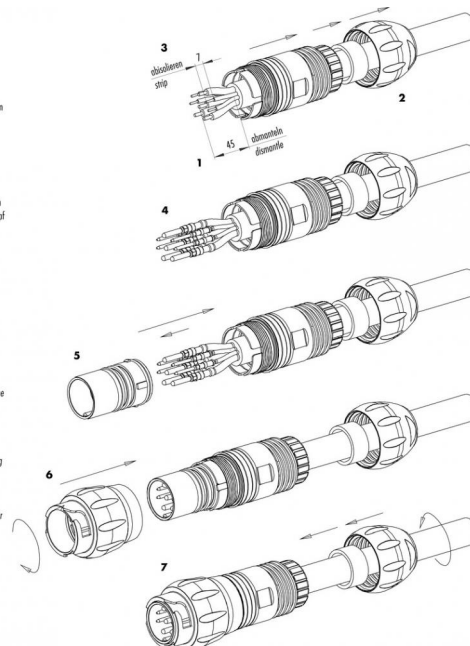

Product **Contacts 8(4 + 3+PE): male cable connector, cable outlet 7-13mm/12-17mm, rated voltage: 60 V Signal, 400 V Power**

Area **Bajonett HEC Power Series 696**

Article number **99 6501 000 08**

Installation instructions / Mounting cutout

1. Abzweifle auf Länge l = 50mm. Umarmung abheben.
2. Druckschraube, Dichtung und Kupplungsbohle auf Kabel aufstecken.
3. Ummantelung abisolieren l = 3,5mm.
4. Kontakte einstecken.
5. Ausgerichtete Kontakte in den Kontaktträger bis zum Einsetzen einrücken und diesen in die Kupplungsbohle bis auf Anschlag schieben.

Achtung! Die Positionierung der Kontakte zum Gehäuse beachten. Der Pfeil zeigt auf die Restfelder des Kontakts.

6. Vorriegelungslehre am Gewinde der Kupplungsbohle aufsetzen und mit leichtem Druck in Pfeilrichtung festschrauben. (empfohlenes Drehmoment 80Nm)
7. Den Dichtung in dem Klemmkorb bis auf Anschlag schieben und mit der Druckschraube festschrauben. (empfohlenes Drehmoment 250Nm)

Lösen der Kontakte:

Da die Kontakte schwimmend gelagert sind, lässt sich das Lösewerkzeug mit leichten Pendelbewegungen bis auf Anschlag vorführen. Danach zum Lösen den Ausdrückknopf betätigen.

- * Compangeze für Einzelkontakte Bestell-Nr. 66 0001 014 100
- Compangeze für Bundkontakte Bestell-Nr. 67 0001 014 100
- Umsenwerkzeug Kontakt Bestell-Nr. 07 0088 000

1. Strip to 45mm length and take off cable jacket.
2. Boot pressing screw, pinch ring, seal and distance sleeve to cable.
3. Strip insulation of the single wires (length 7mm).
4. Insert contacts to single wires.
5. Press aligned contacts into contact carrier until they snap into place. Then push the carrier into the connector sleeve to block.

Attention! Bear in mind the positioning of the contacts in relation to the housing. The mark points to the strip.

6. Put locking unit to the thread of the connector sleeve and screw it with slight pressure towards the direction marked with an arrow until it is tight. (recommended torque 80 dNm)
7. Push sealing ring into the pinch ring to block and fix both by screwing the pressing screw towards the connector sleeve. (recommended torque 250-250 dNm)

Extracting the contacts:

As the contacts are fully floating the extraction tool can be inserted with slight pendular movements to block. Afterwards press the extraction button.

- * Comping tool for single contacts Ordering-No. 66 0001 014 100
- Comping tool for strip contacts Ordering-No. 67 0001 014 100
- Extraction tool for contacts Ordering-No. 07 0088 000

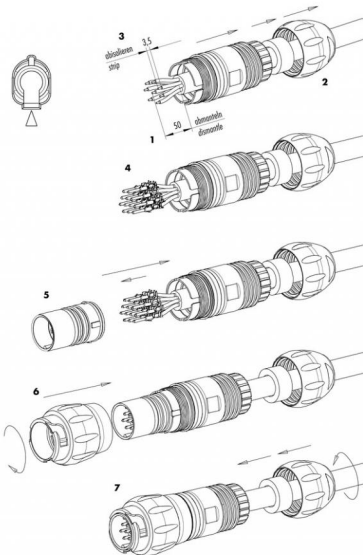

X-ON Electronics

Largest Supplier of Electrical and Electronic Components

Click to view similar products for [binder manufacturer](#):

Other Similar products are found below :

[16-8085-001](#) [16-8100-000](#) [16-8090-000](#) [16-8093-000](#) [09 0330 00 12](#) [09 0153 70 08](#) [09 0301 00 02](#) [09 0305 00 03](#) [09 0337 00 16](#) [09 0477 00 07](#) [09 9478 00 07](#) [66-0004-001](#) [99-9125-60-08](#) [99-9106-60-03](#) [99 0079 100 04](#) [79-3108-52-04](#) [79-3110-52-04](#) [66-0003-001](#) [99-3782-200-08](#) [61-0903-139](#) [09 5283 00 03](#) [09-0316-702-05](#) [66-0005-000](#) [02-0055-001](#) [09-5288-00-08](#) [09-0104-300-02](#) [09-0110-25-04](#) [09-0112-782-04](#) [09-0173-300-08](#) [09-0312-290-04](#) [09-9477-00-07](#) [99-4218-300-07](#) [09-3442-92-05](#) [99-0437-186-05](#) [99-0218-210-07](#) [43-1706-000-04](#) [08-2809-000-000](#) [99-9205-050-03](#) [99-0201-00-07](#) [09-0312-09-04](#) [99-0610-02-04](#) [09-0319-80-05](#) [99-9206-050-03](#) [09-0073-20-02](#) [09-0081-20-04](#) [09-0322-92-06](#) [99-2026-20-07](#) [43-1714-133-03](#) [99-0143-12-06](#) [99-0142-12-05](#)