

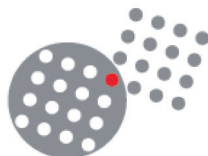

JBX Series

Sealed and Unsealed Push-Pull Connectors



SOURIAU
Connection Technology

JBX Series Push-Pull Connectors



Introduction

This catalog introduces the push-pull connector ranges for industrial applications. These products are particularly suitable for high reliability and high quality applications where a simple yet fast method to connect/disconnect is required. Also suitable for high endurance and ease of operation in very limited spaces. The aesthetics of the product allows for perfect integration on front panel equipments.

Contents

| | |
|--|--------------|
| Where and why push-pull | 4 |
| Selection guide | 5 |
| Push Pull Connectors | |
| • Main features - Part number system..... | 6 |
| • Shell types and dimensions..... | 7-9 |
| • Keying..... | 10 |
| • Contact layouts..... | 11-13 |
| • Options..... | 14 |
| • Technical characteristics..... | 15 |
| • Wiring and assembly instructions..... | 16-21 |
| JBX Series | |
| • Plug Assembly Instructions..... | 22-26 |
| • Receptacle Assembly Instructions | 27-30 |
| Environmentally Sealed Push Pull Connectors | |
| • Main features - Part number system..... | 31 |
| • Shell types and dimensions..... | 31 |
| • Keying - contact layouts..... | 32-33 |
| • Technical characteristics/Options | 34-35 |
| • Wiring and assembly instructions..... | 36 |
| Accessories - Piece parts | 38-39 |
| PCB Layout Patterns | 40-42 |
| Toolings | 43-44 |
| Conversion table | 45 |
| Request form | 46 |



Where and Why push-pull ?

- Extremely fast and easy to use
- A thousand matings / unmatings
- Enhanced appearance to add value to equipment
- Space saving

Medical

Professional audio video

Instrumentation



Telecommunications

GPS

JBX Series Push-Pull Connectors



Selection guide

| Push-Pull | | |
|--|--|-------------------------------------|
| <p style="text-align: center;">Unsealed Multipin</p> <p style="text-align: center;">Solder, Crimp or PCB Contacts</p> <p style="text-align: center;">↓</p> <p style="text-align: center;">Keyed 2 to 30 contacts</p> <p style="text-align: center;">↓</p> <div style="text-align: center;">  </div> <p style="text-align: center;">JBX Series UL recognized</p> | <p style="text-align: center;">Sealed Multipin</p> <p style="text-align: center;">Solder, Crimp or PCB Contact</p> <p style="text-align: center;">↓</p> <p style="text-align: center;">Keyed 2 to 19 contacts</p> <p style="text-align: center;">↓</p> <div style="text-align: center;">  </div> <p style="text-align: center;">Sealed JBX UL recognized</p> | |
| Shell material | Brass | Brass |
| Insulator material | PEEK | PEEK |
| Shielding | Shielded (55 dB up to 100 MHz) | Shielded (55 dB up to 100 MHz) |
| Endurance | > 1 000 cycles | > 1 000 cycles |
| Current rating | up to 30 A | up to 30 A |
| Temperature range | -40°C; +125°C (-58° F; + 257° F) | -40°C; +125°C (-58° F; + 257° F) |
| Protection index | IP40 | IP67 / IP68 |

Push-pull locking system

The locking of the plug into the receptacle is achieved by a simple axial push on the outer shell.

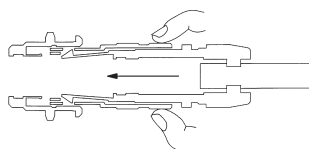

Connection cannot be broken by pulling the cable or any other parts of the plug than the outer shell.

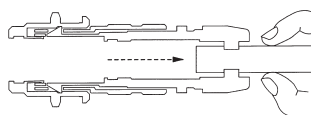

To unmate the plug from the receptacle, just pull axially the outer shell.

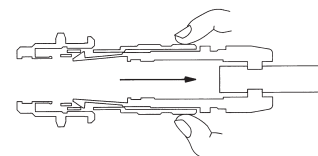

JBX Series Push-Pull Connectors



Major features & benefits

Key features

- Mechanically keyed : ensures correct polarisation and alignment.
- Contact layouts from 2 to 30 contacts.
- Wire gauges range from 30 AWG to 12 AWG.
- High contact density in a small space.
- Contact termination in either crimp, solder, PCB or right angle PCB contacts.



User advantages

Blister packaging



6-collet cluster

Allows a wide range of cable diameter applications for a single connector.

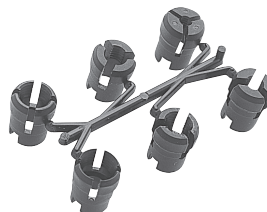

Removable contacts

Available crimp versions allow easier wiring and maintenance

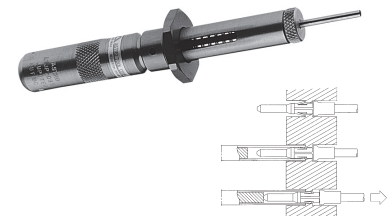

Part number system

| Basic series | JBX | FD | 1 | G | 05 | M | C | S | D | S | M | R |
|-----------------------|---|----|---|---|----|---|---|---|---|---|---|---|
| Shell type-Receptacle | ER-EA-SR-PC-ED-EP-EZ-SA | | | | | | | | | | | |
| Shell type - Plug | FD-FC-FF-FM-FN | | | | | | | | | | | |
| Shell size | 00 - 0 - 1 - 2 - 3 | | | | | | | | | | | |
| Keying | G - J - A - B | | | | | | | | | | | |
| Contact layout | 02 ----- 30 | | | | | | | | | | | |
| Contact type | M : pin F : socket | | | | | | | | | | | |
| Contact termination | C: crimp; S: solder; P*: straight PCB tails ; Q*: Right Angle PCB tails | | | | | | | | | | | |
| Surface plating | S: Outer shell brass alloy chrome over nickel plating N: Outer shell in brass alloy with black plating (consult SOURIAU USA) | | | | | | | | | | | |
| Obligatory Suffix | D: For all part numbers | | | | | | | | | | | |
| Contact Size | S: All contact diameters except .05 mm P: 0.5 mm contact dimensions only | | | | | | | | | | | |
| Cable Backnut Option | M: Connector with backnut for protective boot - Protective boot to order separately page 13 | | | | | | | | | | | |
| Key Identifier | R: Red dot on shell for ED, ER, EZ, PC, SR, FC, FD, FF, FM & FN only | | | | | | | | | | | |

* For receptacle with female contact only

JBX Series Push-Pull Connectors



Shell types

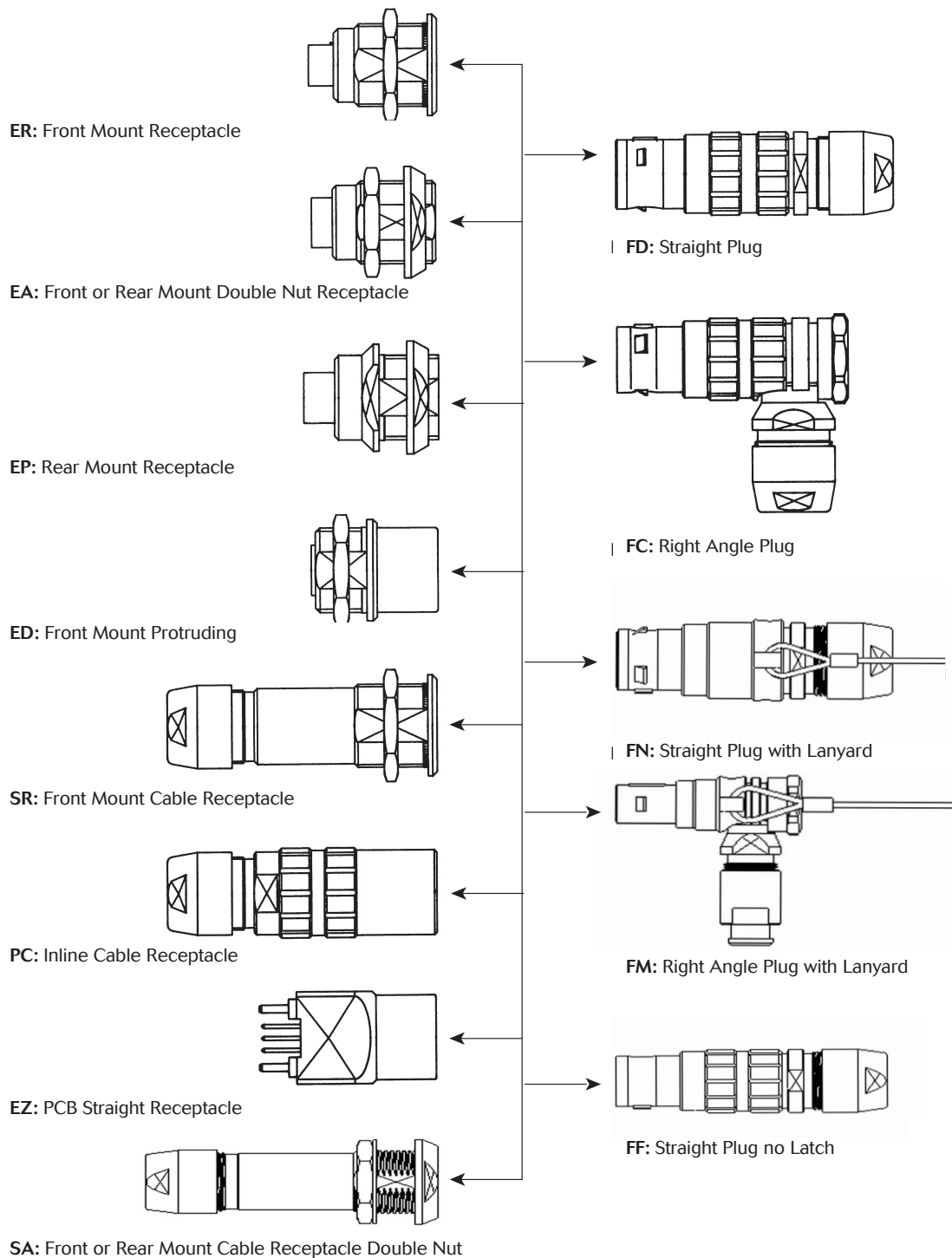

*Appropriate for right angle PCB contacts

JBX Series Push-Pull Connectors



Dimensions - receptacles

ER: Front Mount

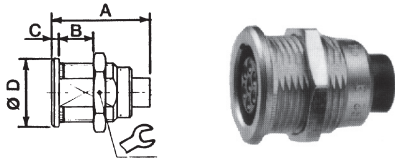

| Size | 00 | 0 | 1 | 2 | 3 |
|------|-----|-----|-----|-----|-----|
| A | 14 | 19 | 21 | 24 | 28 |
| B | 6 | 8 | 10 | 10 | 12 |
| C | 0.8 | 1.2 | 1.5 | 1.8 | 2.0 |
| Ø D | 8 | 10 | 14 | 18 | 22 |

EA: Double Nut

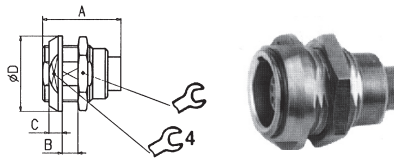

| Size | 0 | 1 | 2 | 3 |
|------|-----|-----|-----|-----|
| A | 19 | 21 | 24 | 28 |
| B | 6.7 | 8.3 | 8 | 9.5 |
| C | 2.5 | 3.2 | 3.8 | 4.5 |
| Ø D | 12 | 16 | 20 | 24 |

EP: Rear Mount

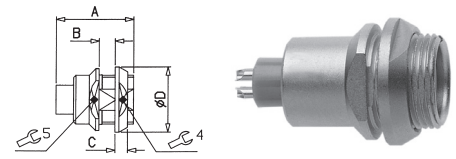

| Size | 0 | 1 | 2 |
|------|-----|-----|-----|
| A | 19 | 21 | 24 |
| B | 4.5 | 6 | 6.5 |
| C | 2.5 | 3.2 | 3.8 |
| Ø D | 12 | 16 | 20 |

SA : Front or Rear Mount Double Nut

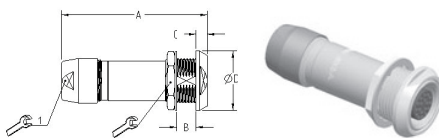

| Size | 0 | 1 | 2 | 3 |
|------|-----|-----|-----|----|
| A | 38 | 43 | 50 | 59 |
| B | - | - | 6.5 | - |
| C | 2.5 | 3.2 | 3.8 | - |
| Ø D | 12 | 16 | 20 | 24 |

ED : Front Mount, Protruding

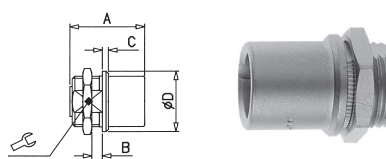

| Size | 0 | 1 | 2 |
|------|-----|-----|-----|
| A | 19 | 21 | 24 |
| B | 3 | 4.5 | 6.3 |
| C | 1.2 | 1.5 | 1.8 |
| Ø D | 10 | 14 | 18 |

SR : Front Mount Cable Receptacle

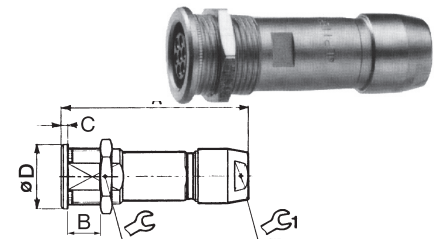

| Size | 0 | 1 | 2 | 3 |
|------|-----|-----|-----|----|
| A | 38 | 43 | 50 | 59 |
| B | 8 | 10 | 10 | 12 |
| C | 1.2 | 1.5 | 1.8 | 2 |
| Ø D | 10 | 14 | 18 | 22 |

PC : In Line Receptacle

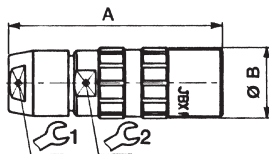
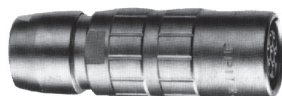

| Size | 0 | 1 | 2 | 3 |
|------|----|----|----|------|
| A | 38 | 43 | 50 | 59 |
| Ø B | 10 | 13 | 16 | 19.5 |

EZ : PCB

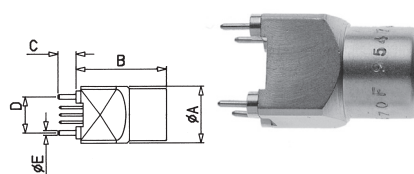

| Size | 0 | 1 |
|------|------|------|
| A | 10 | 12 |
| Ø B | 19 | 21 |
| C | 4 | 4 |
| D | 7.62 | 7.62 |
| Ø E | 1.1 | 1.1 |



JBX Series Push-Pull Connectors

Dimensions - plugs

FC : Straight Plug with Lanyard

| Size | 0 |
|------|------|
| A | 30.5 |
| B | 20.5 |
| C | 29.5 |
| Ø D | 10 |

FM : Right Angle with Lanyard

| Size | 0 | 1 | 2 | 3 |
|------|------|------|------|------|
| A | 30.5 | 36.5 | 42.5 | 50.5 |
| B | 20.5 | 25.5 | 30.5 | 35.5 |
| C | 29.5 | 33.5 | 36.5 | 45 |
| Ø D | 10 | 12 | 15 | 18 |

FF : Straight, no latch

| Size | 0 | 1 | 2 | 3 |
|------|------|------|------|------|
| A | 30.5 | 36.5 | 42.5 | 50.5 |
| B | 20.5 | 25.5 | 30.5 | 35.5 |
| C | 29.5 | 33.5 | 36.5 | 45 |
| Ø D | 10 | 12 | 15 | 18 |

FC : Right Angle

| Size | 0 | 1 | 2 | 3 |
|------|------|------|------|------|
| A | 30.5 | 36.5 | 42.5 | 50.5 |
| B | 20.5 | 25.5 | 30.5 | 35.5 |
| C | 29.5 | 33.5 | 36.5 | 45 |
| Ø D | 10 | 12 | 15 | 18 |

FD : Straight

| Size | 00 | 0 | 1 | 2 | 3 |
|------|----|----|----|----|----|
| A | 31 | 39 | 45 | 52 | 62 |
| B | 23 | 29 | 34 | 40 | 47 |
| Ø C | 7 | 10 | 12 | 15 | 18 |

Range of cable diameters

With the plastic collet set supplied with the standard product, a wide range of cable diameters is allowed. Find below the maximum and the minimum for each size of shell (for information only because it can change with the cable characteristics).

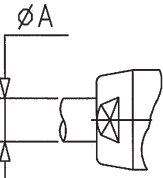

| Size | 00 | 0 | 1 | 2 | 3 |
|---------|-----|-----|-----|-----|------|
| Ø A min | 1.1 | 1.5 | 2.0 | 3.5 | 4.9 |
| Ø A max | 3.5 | 5.5 | 7.5 | 9.7 | 12.0 |

JBX Series Push-Pull Connectors



Keying

Keying angles

JBX Series are mechanically keyed to ensure correct alignment of the inserts before the contacts mate.

«G» : normal inserts ; 0° keying angle, plugs with pin contacts, receptacles with socket contacts

| Key | Single key way | Dual key way | | | |
|--------------|----------------|--------------|----------|-----|-----|
| | G | J | | A | B* |
| | | Size 0-1 | Size 2-3 | | |
| Keying angle | 0° | 45° | 37.5° | 30° | 60° |
| Plug | | | | | |
| Receptacle | | | | | |

Keying shells availability

| Shell size | Key | ER | EA | ED | EP | EZ | SR | PC | FD | FC | SA | FN | FM | FF |
|------------|-----|----|----|----|----|----|----|----|----|----|----|----|----|----|
| 00 | G | ● | ● | | | | | | ● | | | | | |
| 0 | G | ● | ● | ● | ● | ● | ● | ● | ● | ● | ● | ● | ● | |
| | J | ● | ● | ○ | ○ | ○ | ○ | ○ | ● | ● | ○ | ○ | ○ | |
| | A | ● | ○ | ○ | ○ | ○ | ○ | ○ | ● | ○ | ○ | ○ | ○ | |
| | B | ● | ○ | ○ | ○ | ○ | ○ | ○ | ○ | ● | ○ | ○ | ○ | |
| 1 | G | ● | ● | ● | ● | ● | ● | ● | ● | ● | | | | ● |
| | J | ● | ● | ○ | ○ | ○ | ○ | ○ | ● | ● | | | | ○ |
| | A | ● | ○ | ○ | ○ | ○ | ○ | ○ | ● | ○ | | | | ○ |
| | B | ● | ○ | ○ | ○ | ○ | ○ | ○ | ○ | ○ | | | | ○ |
| 2 | G | ● | ● | ● | ● | | ● | ● | ● | ● | ● | | | |
| | J | ● | ● | ○ | ○ | | ○ | ○ | ● | ● | ○ | | | |
| | A | ● | ○ | ○ | ○ | | ○ | ○ | ● | ○ | ○ | | | |
| | B | | ○ | ○ | ○ | | ○ | ○ | ○ | ○ | ○ | | | |
| 3 | G | ● | ● | | | | ● | ● | ● | ● | | | | |

● Available for JBX Series

○ Contact Souriau for lead times

Contact SOURIAU for additional shell style configurations

JBX Series Push-Pull Connectors



Contact layouts

| Shell size 00 | |
|----------------------------|--|
| Male insulator wire side | 04  |
| Solder | S |
| Crimp | |
| PCB straight tails | |
| PCB right angles | |
| Contact diameter mm | 0.5 |
| Solder Max. AWG | 30 |
| Crimp wire Max. AWG | |
| Max current rating | 2 |
| Test voltage (Vrms) | 1000 |
| Working Voltage (Vdc/Vrms) | 500/350 |

Voltage Test Procedure







The **testing voltage** corresponds to the maximum voltage the connector is able to withstand in normal climatic conditions. The value is about 75% of the electrical breakdown voltage. The testing voltage level can be reached several times in connectors life, but never applied for a continuous duration.

The **working voltage** corresponds to the maximum voltage the connector is able to withstand continuously during its life time, in real environmental conditions, even with high temperature. The value is around 1/3 of the testing voltage.

Maximum current rating

This **indicated maximum current rating** corresponds to the maximum current that can be applied **simultaneously on each line of the connector mated pair**, continuously during its life time, in normal climatic conditions.

Remark : If the current is applied on only one contact of the layout, then an increased current value can be achieved over a long duration.

| Shell size 0 | | | | | | | |
|----------------------------|---|---|---|--|---|---|---|
| | 02 | 03 | 04 | 05 | 06 | 07 | 08 |
| Male insulator wire side |  |  |  |  |  |  |  |
| Solder | S | S | S** | S** | S** | S** | S** |
| Crimp | C | C | C | C | P* | P* | P* |
| PCB straight tails* | P* | P* | P* | P* | P* | P* | P* |
| PCB right angles* | Q* | Q* | Q* | Q* | P* | P* | P* |
| Contact diameter mm | 0.9 | 0.9 | 0.7 | 0.7 | 0.5 | 0.5 | 0.5 |
| Solder Max. AWG | 24 | 24 | 26 | 26 | 28 | 28 | 28 |
| Crimp wire Max. AWG | 20 | 20 | 22 | 22 | 2.5 | 2.5 | 2 |
| Max current rating | 10 | 8 | 7 | 6.5 | 2.5 | 2.5 | 2 |
| Test voltage (Vrms) | 1400 | 1300 | 1350 | 800 | 680 | 680 | 680 |
| Working Voltage (Vdc/Vrms) | 600/460 | 600/420 | 600/4205 | 400/220 | 320/220 | 320/220 | 320/220 |

**Inserts with fixed non removable contacts* For receptacles with female contacts. -

Note : Contact numbering mating faces receptacle view: counterclockwise from key at position 1 -
Contact numbering mating faces plug view: clockwise from key at position 1

JBX Series Push-Pull Connectors



Contact layouts

| Shell size 1 | | | | | | | | | |
|----------------------------|---------|---------|---------|---------|---------|---------|---------|---------|---------|
| | 02 | 03 | 04 | 05 | 06 | 07 | 08 | 10 | 12 |
| Male insulator wire side | | | | | | | | | |
| Solder | S | S | S | S | S** | S** | S** | S** | S** |
| Crimp | C | C | C | C | C | C | C | | |
| PCB straight tails* | P* | P* | P* | P* | P* | P* | P* | P* | P* |
| PCB right angles* | | Q* | Q* | Q* | Q* | Q* | Q* | | |
| Contact diameter mm | 1.3 | 1.3 | 0.9 | 0.9 | 0.7 | 0.7 | 0.7 | 0.5 | 0.5 |
| Solder Max. AWG | 20 | 20 | 24 | 24 | 26 | 26 | 26 | 28 | 28 |
| Crimp wire Max. AWG | 18 | 18 | 20 | 20 | 22 | 22 | 22 | | |
| Max current rating | 15 | 12 | 10 | 9 | 7 | 7 | 5 | 2.5 | 2.5 |
| Test voltage (Vrms) | 1600 | 1300 | 1900 | 1400 | 1400 | 1400 | 1200 | 600 | 500 |
| Working Voltage (Vdc/Vrms) | 760/530 | 600/420 | 900/630 | 660/460 | 600/460 | 600/460 | 600/420 | 300/200 | 275/175 |

| Shell size 2 | | | | | | | |
|----------------------------|----------|---------|----------|---------|---------|---------|---------|
| | 02 | 03 | 04 | 05 | 06 | 07 | 08 |
| Male insulator wire side | | | | | | | |
| Solder | S | S | S | S | S | S | S |
| Crimp | C | C | C | C | C | C | C |
| PCB straight tails* | | | P* | P* | P* | P* | P* |
| PCB right angles* | | | Q* | Q* | Q* | Q* | Q* |
| Contact diameter mm | 2.0 | 1.6 | 1.3 | 1.3 | 1.3 | 1.3 | 0.9 |
| Solder Max. AWG | 16 | 18 | 20 | 20 | 20 | 20 | 24 |
| Crimp wire Max. AWG | 12 | 14 | 18 | 18 | 18 | 18 | 20 |
| Max current rating | 30 | 17 | 15 | 14 | 12 | 11 | 10 |
| Test voltage (Vrms) | 2100 | 1700 | 2400 | 1900 | 1900 | 1500 | 1700 |
| Working Voltage (Vdc/Vrms) | 1000/700 | 830/560 | 1000/800 | 900/630 | 900/630 | 730/500 | 830/560 |

**Inserts with fixed non removable contacts * For receptacles with female contacts. XX Contact SOURIAU

Note : Contact numbering mating faces receptacle view: counterclockwise from key at position 1

Contact numbering mating faces plug view: clockwise from key at position 1

JBX Series Push-Pull Connectors



| Shell size 2 | | | | | |
|----------------------------|---------|---------|---------|---------|---------|
| | 10 | 12 | 16 | 18 | 19 |
| Male insulator wire side | | | | | |
| Solder | S | S** | S** | S** | S** |
| Crimp | C | C | C | C | C |
| PCB straight tails* | P* | P* | P* | P* | P* |
| PCB right angles* | Q* | Q* | Q* | | |
| Contact diameter mm | 0.9 | 0.7 | 0.7 | 0.7 | 0.7 |
| Solder Max. AWG | 24 | 26 | 26 | 26 | 26 |
| Crimp wire Max. AWG | 20 | 22 | 22 | 22 | 22 |
| Max current rating | 8 | 7 | 6 | 5.5 | 5 |
| Test voltage (Vrms) | 1700 | 1700 | 1500 | 1400 | 1400 |
| Working Voltage (Vdc/Vrms) | 830/560 | 830/560 | 730/500 | 660/460 | 660/460 |

| Shell size 3 | | | | | | | | | |
|----------------------------|-----------|----------|----------|---------|---------|---------|---------|---------|---------|
| | 03 | 04 | 07 | 08 | 10 | 14 | 18 | 22 | 30 |
| Male insulator wire side | | | | | | | | | |
| Solder | S** | S** | S | S | S | S | S | S** | S** |
| Crimp | C | C | C | C | C | C | C | C | C |
| PCB straight tails | | | | P* | P* | P* | P* | P* | P* |
| PCB right angles | | | | | | | | | |
| Contact diameter mm | 2.0 | 2.0 | 1.6 | 1.3 | 1.3 | 0.9 | 0.9 | 0.7 | 0.7 |
| Solder Max. AWG | 16 | 16 | 16 | 20 | 20 | 24 | 24 | 26 | 26 |
| Crimp wire Max. AWG | 12 | 12 | 14 | 18 | 18 | 20 | 20 | 22 | 26 |
| Max current rating | 25 | 25 | 15 | 12 | 12 | 9 | 7 | 5.5 | 3.5 |
| Test voltage (Vrms) | 3600 | 2500 | 2200 | 2000 | 1400 | 1700 | 1400 | 1200 | 800 |
| Working Voltage (Vdc/Vrms) | 1600/1200 | 1100/830 | 1100/730 | 830/560 | 660/460 | 830/560 | 660/460 | 560/400 | 400/260 |

**Inserts with fixed non removable contacts * For receptacles with female contacts. XX Contact SOURIAU

Note : Contact numbering mating faces receptacle view: counterclockwise from key at position 1

Contact numbering mating faces plug view: clockwise from key at position 1

JBX Series Push-Pull Connectors



Options

Protective boot

With each JBX connector, one protective boot can accept diverse cable diameters thus the end-user can manage various cable diameters with one SOURIAU part number.

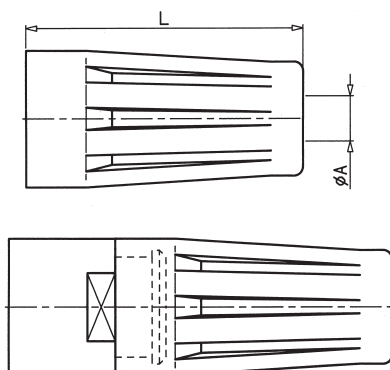

| Part number | Shell size | Dimensions | | | |
|-------------|------------|------------|----|---------|-----|
| | | Ø A | L | Ø Cable | |
| | | | | Min | Max |
| JBX 00 MPN | 00 | 1.5 | 15 | 1 | 3.5 |
| JBX 0 MP* | 0 | 2.2 | 20 | 1.5 | 5.5 |
| JBX 1 MP * | 1 | 2.6 | 25 | 2 | 7.5 |
| JBX 2 MP * | 2 | 4 | 30 | 3.5 | 9.7 |
| JBX 3 MP* | 3 | 5 | 35 | 4.9 | 12 |

*Color code - see chart below / in size 00 available only in black

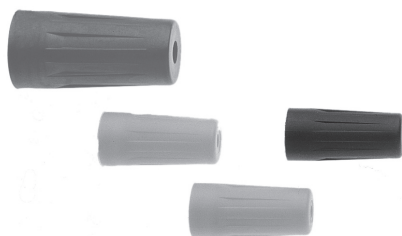

| Color Code | Colors |
|------------|--------|
| A | blue |
| B | white |
| G | grey |
| J | yellow |
| M | brown |
| N | black |
| R | red |
| V | green |
| O | orange |

Material :
ELASTOLLAN (PUR)

Working temperature :
- 40°C ; + 80°C
- 40°F ; + 176°F

Parts that require a protective boot need to be ordered with an M suffix. **Protective boots are ordered separately.**

Caps : an efficient protection against dust

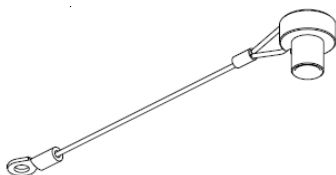

| Receptacle caps | | Plug caps | |
|-----------------|------------|-------------|------------|
| Part number | Shell size | Part number | Shell size |
| | | JBX BF00 | 00 |
| JBX BR0 | 0 | JBX BF0 | 0 |
| JBX BR1 | 1 | JBX BF1 | 1 |
| JBX BR2 | 2 | JBX BF2 | 2 |
| JBX BR3 | 3 | JBXBF3 | 3 |

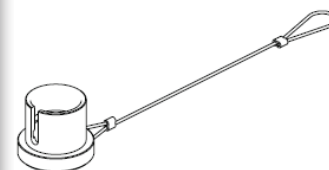

JBX Series Push-Pull Connectors



Technical characteristics

Material and treatment

UL recognized - homologation file E118235



| Component | Material | Standard | | Surface treatment (µm) | | |
|----------------------------|------------------|-----------|-------------|------------------------|-------|-----|
| | | ISO | ASTM | Cr | Ni | Au |
| Outer shell and collet nut | Brass | CuZn40Pb3 | C38500/C360 | 0.1 - 0.6 | 5 - 8 | - |
| Latching sleeve | Brass | CuZn40Pb3 | C38500/C360 | - | 5 - 8 | - |
| Shielding ring | Brass | CuZn40Pb3 | C38500/C360 | - | 3 - 7 | - |
| Nut | Brass | CuZn40Pb3 | C38500/C360 | - | 5 - 8 | - |
| Half bushes | Brass | CuZn40Pb3 | C38500/C360 | - | 5 - 8 | - |
| Socket contact (1) | Cupro-nickel | CuNi1Pb1P | CDAC19150 | - | 3 - 5 | 0.5 |
| Pin contact (1) | Brass | CuZn35Pb2 | C35300/C360 | - | 3 - 5 | 0.5 |
| Clip | Beryllium copper | CuBe1,9 | C17200/C360 | - | - | - |

(1) Gold thickness as per MIL-G-45204C type 1, class 00

| Component | Material | Color | Working temperature | |
|-----------|---------------|-------|---------------------|----------------|
| Insert | PEEK +15% GF | brown | - 50°C + 250°C | - 58°F + 482°F |
| Collet | PA 6/6 + MoS2 | black | - 55°C + 125°C | - 67°F + 257°F |

| Characteristics | Values | Mil Standard | Method | IEC Standard |
|-----------------------|---|---------------|--------|---------------|
| Endurance | > 1000 cycles (except for 0.7 mm crimp contacts for which endurance is limited to 500 cycles) | MIL-STD 1344A | 2016.1 | IEC60512-5-9a |
| Shock | 50g, duration 6 ms; contact Ø 0.7 mm and 0.9mm 100 g, duration 6 ms; contact Ø 1.3 mm - 1.6 mm and 2 mm | MIL-STD 1344A | 2004.1 | |
| Vibrations | >10 to 2000 Hz $\gamma = 15g$, contact Ø 0.7 mm and 0.9mm $\gamma = 20g$, contact Ø 1.3 mm - 1.6 mm and 2mm | MIL-STD 1344A | 2005.1 | |
| Protection Index | IP 40 | | | IEC60529 |
| Operating Temperature | with plastic collets } - 55°C + 125°C - 67°F + 257°F with optional metal collets } - 55°C + 200°C - 67°F + 392°F Only on request, consult SOURIAU | | | |

JBX Series Push-Pull Connectors



Wiring & assembly instructions

Panel cutout

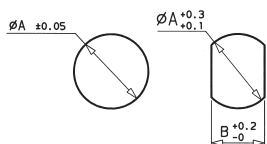

| Size | 00 | 0 | 1 | 2 | 3 |
|-----------------|-----|-----|------|------|------|
| $\varnothing A$ | 7.1 | 9.1 | 12.1 | 15.1 | 18.1 |
| B | 6.4 | 8.3 | 10.6 | 13.6 | 16.6 |

Removable contacts

Reliable design

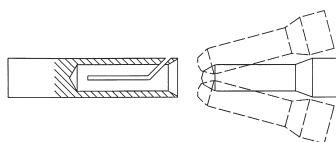

- Conical entry with chamfered edge on the socket contact and smooth slope on the pin contact ensure perfect concentric mating even when handled carelessly.
- The pressure spring of the socket contact maintains a constant force on the pin contact when mated.

Crimp contacts

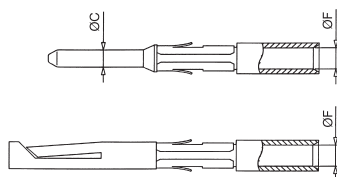

| Contact | | Usable cables | | | Max. current rating (A) | Contact resistance (m Ω) | Endurance (number of cycles) |
|-----------------|-----------------|-------------------------|-------|----------|-------------------------|----------------------------------|------------------------------|
| $\varnothing C$ | $\varnothing F$ | Core section (mm 2) | | AWG | | | |
| | | Min | Max. | | | | |
| 0.7 | 0.85 | 0.129 | 0.326 | 22-24-26 | 7 | 5 | 500 Max. |
| 0.9 | 1.1 | 0.205 | 0.518 | 20-22-24 | 10 | 3.5 | > 1000 |
| 1.3 | 1.4 | 0.326 | 0.823 | 18-20-22 | 15 | 3 | > 1000 |
| 1.6 | 1.9 | 0.823 | 2.081 | 14-16-18 | 17 | 2.5 | > 1000 |
| 2.0 | 2.4 | 1.309 | 3.309 | 12-14-16 | 30 | 2.5 | > 1000 |

Solder contacts

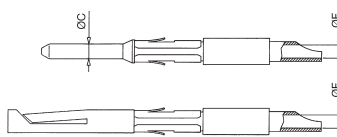

| Contact | | Usable cables | | | Max. current rating (A) | Contact resistance (m Ω) | Endurance (number of cycles) |
|-----------------|-----------------|-------------------------|------|-----|-------------------------|----------------------------------|------------------------------|
| $\varnothing C$ | $\varnothing F$ | Core section (mm 2) | | AWG | | | |
| | | Min | Max. | | | | |
| 0.7 | 0.7 | - | 0.30 | 26 | 7 | 5 | 500 Max. |
| 0.9 | 0.8 | - | 0.21 | 24 | 10 | 3.5 | > 1000 |
| 1.3 | 1.1 | - | 0.60 | 20 | 15 | 3 | > 1000 |
| 1.6 | 1.5 | - | 0.93 | 18 | 17 | 2.5 | > 1000 |
| 2 | 1.9 | - | 1.34 | 16 | 30 | 2.5 | > 1000 |

The conductor bucket on the solder contacts is designed with an angle to form a cup into which the solder can flow easily.

Fixed contacts

Solder contacts

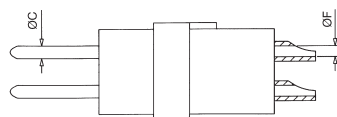

| Contact | | Shell size | Usable cables | | Max. current rating (A) | Contact resistance (m Ω) | Endurance (number of cycles) |
|-----------------|-----------------|------------|-------------------------|-----|-------------------------|----------------------------------|------------------------------|
| $\varnothing C$ | $\varnothing F$ | | Core section (mm 2) | AWG | | | |
| 0.5 | 0.4 | 00 | 0.06 | 30 | 5 | 10 | > 1000 |
| | 0.5 | 0 - 1 | 0.096 | 28 | | | |
| 0.7 | 0.63 | 0-1-2-3 | 0.15 | 26 | 7 | 5 | > 1000 |

Contacts for PCB

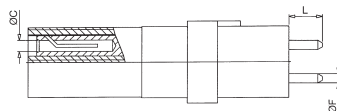

| Contacts for PCB | | Contact length dimensions "L" |
|--------------------------------------|--|--|
| PCB tail length size 0 | | dimension "L" 5.5 mm |
| 0.7 mm female PCB tail length size 0 | | dimension "L" 3.5 mm |
| 0.7 mm female PCB tail length size 1 | | dimension "L" 4.0 mm |
| 0.7 mm female PCB tail length size 2 | | dimension "L" 6.0 mm |
| 0.7 mm female PCB tail length size 3 | | dimension "L" 6.0 mm |
| 0.9 mm female PCB tail length size 0 | | dimension "L" 3.5 mm |
| 0.9 mm female PCB tail length size 1 | | dimension "L" 4.0 mm |
| 0.9 mm female PCB tail length size 2 | | dimension "L" 6.0 mm |
| 4.3 mm female PCB tail length size 1 | | dimension "L" 4.0 mm, dimension "F" 0.7 mm |
| 4.3 mm female PCB tail length size 2 | | dimension "L" 6.0 mm, dimension "F" 0.7 mm |
| 4.3 mm female PCB tail length size 3 | | dimension "L" 6.0 mm, dimension "F" 0.7 mm |

JBX Series Push-Pull Connectors



Cable stripping for connectors with crimp contacts

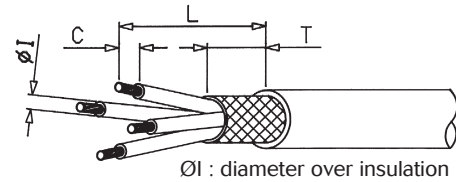

| Shell Size | Ø Contacts | Ø I | Stripping for FD, SR, PC | | | Stripping for FC | | |
|------------|------------|--------|--------------------------|-----|----|------------------|-----|----|
| | | | L | C | T | L | C | T |
| 0 | 0.7 | ≤ 1.35 | 15 | 4 | 7 | 19 | 4 | 7 |
| | | > 1.35 | | 5.5 | | | 5.5 | |
| 0 | 0.9 | ≤ 1.6 | 15 | 4 | 7 | 19 | 4 | 7 |
| | | > 1.6 | | 5.5 | | | 5.5 | |
| 1 | 0.7 | ≤ 1.35 | 16 | 4 | 8 | 22 | 4 | 8 |
| | | > 1.35 | | 5.5 | | | 5.5 | |
| | 0.9 | ≤ 1.6 | 16 | 4 | 8 | 22 | 4 | 8 |
| | | > 1.6 | | 5.5 | | | 5.5 | |
| | 1.3 | ≤ 2.1 | 16 | 4 | 8 | 22 | 4 | 8 |
| | | > 2.1 | | 5.5 | | | 5.5 | |
| 2 | 0.7 | ≤ 1.35 | 19 | 4 | 9 | 28 | 4 | 9 |
| | | > 1.35 | | 5.5 | | | 5.5 | |
| | 0.9 | ≤ 1.6 | 19 | 4 | 9 | 28 | 4 | 9 |
| | | > 1.6 | | 5.5 | | | 5.5 | |
| | 1.3 | ≤ 2.1 | 19 | 4 | 9 | 28 | 4 | 9 |
| | | > 2.1 | | 5.5 | | | 5.5 | |
| | 1.6 | ≤ 2.6 | 21 | 5.5 | 9 | 28 | 5.5 | 9 |
| | | > 2.6 | | 7 | | | 7 | |
| | 2.0 | ≤ 3.2 | 21 | 5.5 | 9 | 28 | 5.5 | 9 |
| | | > 3.2 | | 7 | | | 7 | |
| 3 | 0.7 | ≤ 1.35 | 25 | 4 | 10 | 35 | 4 | 10 |
| | | > 1.35 | | 7 | | | 7 | |
| | 0.9 | ≤ 1.6 | 25 | 4 | 10 | 35 | 4 | 10 |
| | | > 1.6 | | 7 | | | 7 | |
| | 1.3 | ≤ 2.1 | 25 | 4 | 10 | 35 | 4 | 10 |
| | | > 2.1 | | 7 | | | 7 | |
| | 1.6 | ≤ 2.6 | 27 | 5.5 | 10 | 35 | 5.5 | 10 |
| | | > 2.6 | | 8.5 | | | 8.5 | |
| | 2.0 | ≤ 3.2 | 27 | 5.5 | 10 | 35 | 5.5 | 10 |
| | | > 3.2 | | 8.5 | | | 8.5 | |

Cable stripping for connectors with crimp contacts

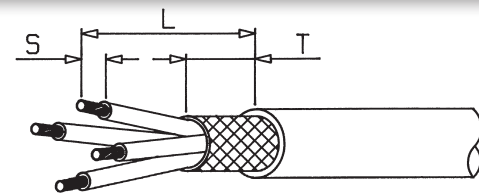

| Shell Size | Ø Contacts | Stripping for FD, SR, PC | | | Stripping for FC | | |
|------------|------------|--------------------------|-----|----|------------------|-----|----|
| | | L | S | T | L | S | T |
| 00 | 0.5 | 9 | 2 | 4 | / | / | / |
| 0 | 0.5 | 11 | 2 | 7 | 16 | 2 | 7 |
| | 0.7 | 12 | 3 | 7 | 16 | 3 | 7 |
| | 0.9 | 12 | 3 | 7 | 16 | 3 | 7 |
| 1 | 0.5 | 12 | 2 | 8 | 19 | 2 | 8 |
| | 0.7 | 13 | 3 | 8 | 19 | 3 | 8 |
| | 0.9 | 13 | 3 | 8 | 19 | 3 | 8 |
| | 1.3 | 13 | 3.5 | 8 | 19 | 3.5 | 8 |
| 2 | 0.7 | 16 | 3 | 9 | 25 | 3 | 9 |
| | 0.9 | 16 | 3 | 9 | 25 | 3 | 9 |
| | 1.3 | 16 | 3.5 | 9 | 25 | 3.5 | 9 |
| | 1.6 | 18 | 4 | 9 | 25 | 4 | 9 |
| | 2 | 18 | 4 | 9 | 25 | 4 | 9 |
| 3 | 0.7 | 20 | 3 | 10 | 30 | 3 | 10 |
| | 0.9 | 20 | 3 | 10 | 30 | 3 | 10 |
| | 1.3 | 20 | 3.5 | 10 | 30 | 3.5 | 10 |
| | 1.6 | 22 | 4 | 10 | 30 | 4 | 10 |
| | 2 | 22 | 4 | 10 | 30 | 4 | 10 |

JBX Series Push-Pull Connectors



Wiring & assembly instructions

Straight plug

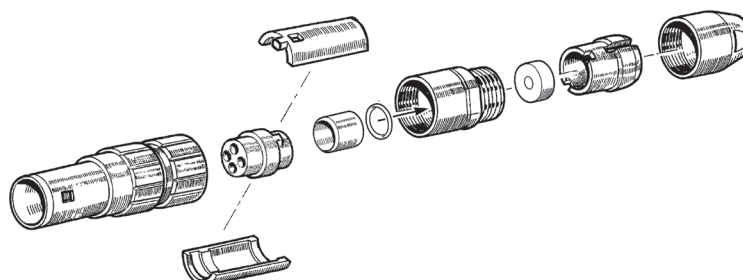

Cable stripping : see page 17

Connector preparation

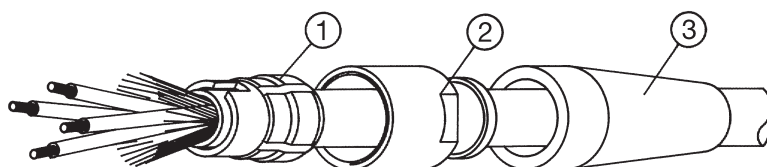

- 1 - Select the proper collet ①. (see page 20)
- 2 - Slide the protective boot ③ the backnut ② and the collet ① onto the cable.
- 3 - In case of a screened cable, combs out the screen and fold back over the collet ①.

Contact wiring : crimp contacts

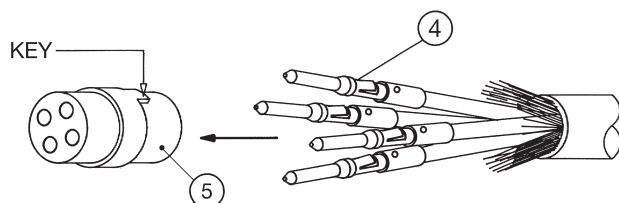

- 1 - Select the proper crimping tool (see page 29) and locator according to the connectors involved.
- 2 - Adjust the tool selector for the corresponding conductor AWG.
- 3 - Crimp the contacts ④ and then engage them into the insert cavities ⑤ till clip tightening.

Contact wiring : solder contacts

| Fixed solder contacts 0.5 mm and 0.7 mm | Removable solder contacts from 0.9 mm to 2 mm |
|---|--|
| 1 - Terminate the bucket contacts using solder method | 1 - Solder the conductors to the contact buckets then engage them into the insert cavities ⑤ till clip holding |

Connector assembly

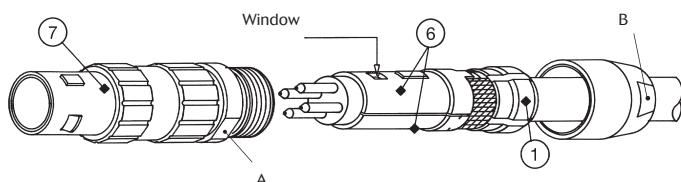

- 1 - Position 2 half bushes ⑥ on the insert ⑤ making sure that the insert key appears through window of one bush.
- 2 - Position the collet and the half bushes while maintaining the screen. Bushing keys are seated in the collet keying slots.
- 3 - Position all the sub-assembly in the connector housing ⑦ making sure to keep sub-assembly aligned.
- 4 - Install the backnut ② and screw it. Use the two wrenches well positionned on the flats A and B. Place a wrench to grip flats B, use the other wrench to tighten the backnut at the flats A. Contact factory for proper torque values.
- 5 - Install the protective boot ③ if exists.

JBX Series Push-Pull Connectors



90° Elbow plug

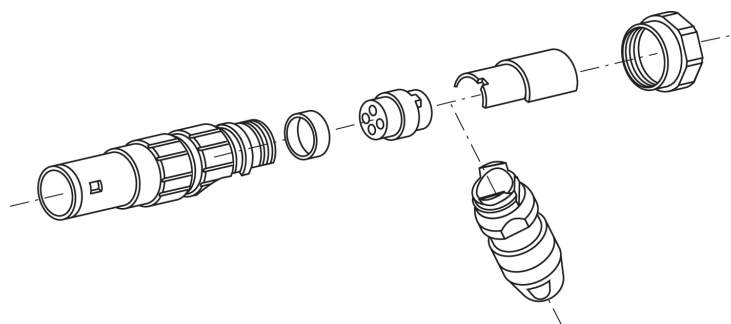

Cable stripping : see page 17

Connector preparation

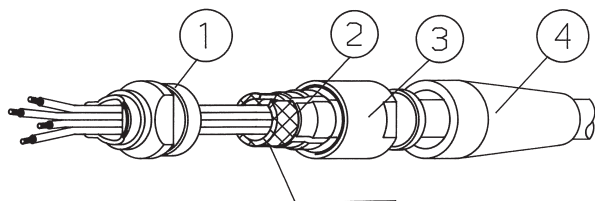

- 1 - Select the proper collet ② (see page 20).
- 2 - Slide the protective boot, ④ the backnut ③, the collet ② and the elbow outlet ① onto the cable.
- 3 - In case of a screened cable, comb out the screen and fold back over the collet ②.
- 4 - Position in the elbow outlet making sure the anti-rotating keys are well aligned.
- 5 - Tighten the backnut ③ till bottomed.
- 6 - Install the protective boot ④ if exists.

Contact wiring : crimp contacts

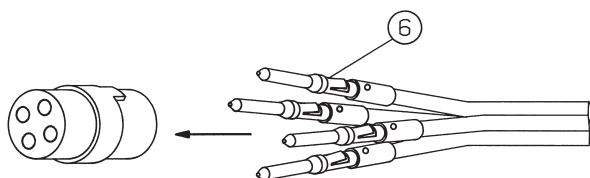

- 1 - Select the proper crimping tool (see page 29) and position according to connectors involved.
- 2 - Adjust the tool selector for the corresponding conductor AWG.
- 3 - Crimp the contacts ⑥ then engage them into the insert cavities ⑤ till clip tightening.

Contact wiring : solder contacts

| Fixed solder contacts 0.5 mm and 0.7 mm | Removable solder contacts from 0.9 mm to 2 mm |
|---|--|
| 1 - Terminate the bucket contacts using solder method | 1 - Solder the conductors to the contact buckets then engage them into the insert cavities ⑤ till clip holding |

Connector assembly

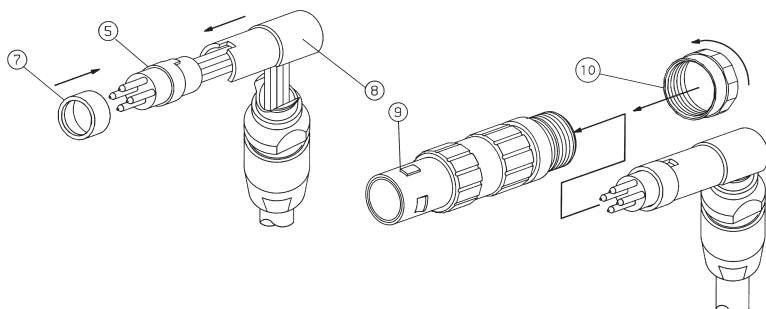

- 1 - Position the ring ⑦ on the insert ⑤ then engage all in the spacer ⑧
- 2 - Position all the sub-assembly in the connector housing ⑨ with milled flats A of the elbow outlet facing to the rear of the plug housing.
- 3 - Tighten the screw ⑩ Contact factory for proper torque values.



JBX Series Push-Pull Connectors

Wiring & assembly instructions

Collets selection according to cable diameters

4 or 6 collets per shell size allow a wide range of cable diameters for a single connector ; outer cable diameters are for reference only, since values will change with specific manufacturers cable properties.

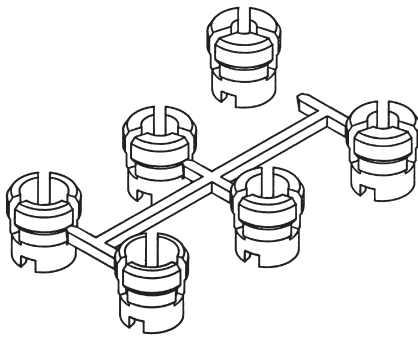

| Collet number | Cable diameter | | | | |
|---------------|----------------|--------------|--------------|--------------|--------------|
| | Shell size 00 | Shell size 0 | Shell size 1 | Shell size 2 | Shell size 3 |
| 1 | 1.1 - 1.9 | 1.5 - 2.5 | 2.0 - 2.5 | 3.5 - 4.7 | 4.9 - 6 |
| 2 | 2 - 28.8 | 2.6 - 3.5 | 2.6 - 3.5 | 4.8 - 5.7 | 6.1 - 7.2 |
| 3 | 2.9 - 3.5 | 3.6 - 4.5 | 3.6 - 4.5 | 5.8 - 6.7 | 7.3 - 8.4 |
| 4 | - | 4.6 - 5.5 | 4.6 - 5.5 | 6.8 - 7.7 | 8.5 - 9.6 |
| 5 | - | - | 5.6 - 6.6 | 7.8 - 7.7 | 9.7 - 10.8 |
| 6 | - | - | 6.7 - 7.5 | 8.8 - 9.7 | 10.9 - 12.0 |

Metal collets

Optional discrete cable diameter metal collets are available. Part numbers can be configured by replacing the obligatory "D" character with maximum cable diameter from the chart below:

| Shell size | Cable diameter |
|------------|----------------------------|
| 0 | 19, 25, 35, 45, 55, 57 |
| 1 | 25, 35, 45, 55, 66, 75, 77 |
| 2 | 47, 57, 67, 77, 87, 97 |
| 3 | 60, 72, 84, 96, 108, 120 |

Metal collet available for all sizes

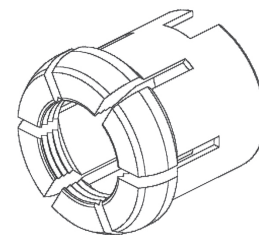

Discreet application based on cable diameter

JBX Series Push-Pull Connectors



Coupling torques

| Tools (jaw dimensions) | 7 x 0.5 | 9 x 0.6 | 12 x 1 | 15 x 1 | 18 x 1 | Advised torques* in Nm |
|---------------------------|---------|---------|--------|--------|--------|---|
| Size | 00 | 0 | 1 | 2 | 3 | |
| | 7 | 11 | 14 | 17 | 21 | Please call Souriau Technical Support for additional information at 717-718-2662 technicalsupport@souriau.com |
| | 6 | 8 | 10 | 13 | 15 | |
| | 6 | 9 | 11 | 14 | 16 | |
| | - | 10 | 12 | 15 | 17 | |
| | - | 10 | 13 | 17 | 20 | |
| | - | 9 | 13 | 15 | - | |

Torque values are the maximum allowable for each connector size.
Torque values will vary due to the type and size of the cable used.
*Apply thread lock to back nut prior to assembly.
Note : All the tooling numbers refer to the drawings pages 8 and 9.

Shielding

Tested according to MIL-STD 1344 A, method 3007

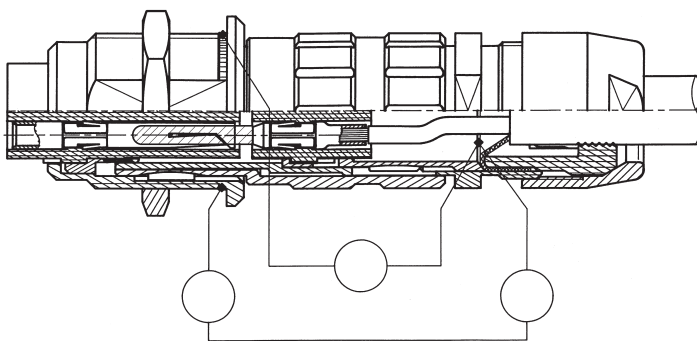

| Shell size | Electrical continuity (mΩ) |
|------------|----------------------------|
| 00 | 4.5 |
| 0 | 4 |
| 1 | 3 |
| 2 | 2.5 |
| 3 | 2.5 |

JBX Series Push-Pull Connectors



Plug assembly instructions

1. Determine what size cable you will be using. Then select the proper collet number for that cable.

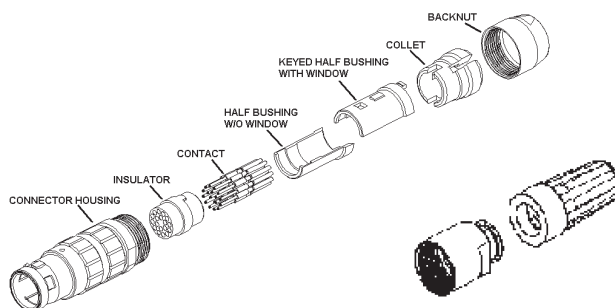

Collets selection according to cable diameters

3 or 5 collets per shell size allow a wide range of cable diameters for a single connector. Cable out diameters are for information only, since values will change with each cable construction.

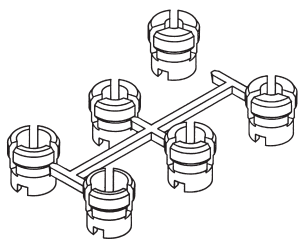

| Collet Number | Cable diameter | | | |
|---------------|----------------|-----------------|--------------|---------------|
| | Shell size 1 | Size O option G | Shell size 1 | Size option G |
| 1 | 1.5 - 2.5 | - | 2 - 2.5 | - |
| 2 | 2.6 - 3.5 | - | 2.6 - 3.5 | - |
| 3 | 3.6 - 4.5 | - | 3.6 - 4.5 | 6.1 - 6.7 |
| 4 | - | 4.6 - 5.5 | 4.6 - 5.5 | 6.8 - 7.7 |
| 5 | - | 5.6 - 6 | 5.6 - 6 | 7.8 - 8 |

Collet number 4 in shell size 0 and collet number 6 in shell size 1 are not used

2. Strip the cable and each wire to the required strip length.

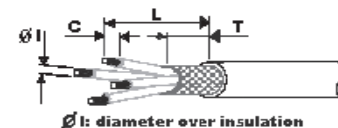

Cable stripping for connectors with crimp contacts

| Shell Size | Ø Contacts | Ø I | Stripping for FD, SR, PC | | | Stripping for FC | | |
|------------|------------|--------|--------------------------|-----|----|------------------|-----|----|
| | | | L | C | T | L | C | T |
| 0 | 0.7 | ≤ 1.35 | 15 | 4 | 7 | 19 | 4 | 7 |
| | | > 1.35 | | 5.5 | | | 5.5 | |
| | 0.9 | ≤ 1.6 | 15 | 4 | 7 | 19 | 4 | 7 |
| | | > 1.6 | | 5.5 | | | 5.5 | |
| 1 | 0.7 | ≤ 1.35 | 16 | 4 | 8 | 22 | 4 | 8 |
| | | > 1.35 | | 5.5 | | | 5.5 | |
| | 0.9 | ≤ 1.6 | 16 | 4 | 8 | 22 | 4 | 8 |
| | | > 1.6 | | 5.5 | | | 5.5 | |
| | 1.3 | ≤ 2.1 | 16 | 4 | 8 | 22 | 4 | 8 |
| | | > 2.1 | | 5.5 | | | 5.5 | |
| 2 | 0.7 | ≤ 1.35 | 19 | 4 | 9 | 28 | 4 | 9 |
| | | > 1.35 | | 5.5 | | | 5.5 | |
| | 0.9 | ≤ 1.6 | 19 | 4 | 9 | 28 | 4 | 9 |
| | | > 1.6 | | 5.5 | | | 5.5 | |
| | 1.3 | ≤ 2.1 | 19 | 4 | 9 | 28 | 4 | 9 |
| | | > 2.1 | | 5.5 | | | 5.5 | |
| | 1.6 | ≤ 2.6 | 21 | 5.5 | 9 | 28 | 5.5 | 9 |
| | | > 2.6 | | 7 | | | 7 | |
| 2.0 | ≤ 3.2 | 21 | 5.5 | 9 | 28 | 5.5 | 9 | |
| | > 3.2 | | 7 | | | 7 | | |
| 3 | 0.7 | ≤ 1.35 | 25 | 4 | 10 | 35 | 4 | 10 |
| | | > 1.35 | | 7 | | | 7 | |
| | 0.9 | ≤ 1.6 | 25 | 4 | 10 | 35 | 4 | 10 |
| | | > 1.6 | | 7 | | | 7 | |
| | 1.3 | ≤ 2.1 | 25 | 4 | 10 | 35 | 4 | 10 |
| | | > 2.1 | | 7 | | | 7 | |
| | 1.6 | ≤ 2.6 | 27 | 5.5 | 10 | 35 | 5.5 | 10 |
| | | > 2.6 | | 8.5 | | | 8.5 | |
| | 2.0 | ≤ 3.2 | 27 | 5.5 | 10 | 35 | 5.5 | 10 |
| | | > 3.2 | | 8.5 | | | 8.5 | |

JBX Series Push-Pull Connectors



Cable stripping for connectors with solder contacts

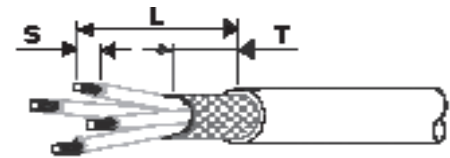

| Shell size | Ø Contact | Stripping for FD, SR, PC | | | Stripping for FC | | |
|------------|-----------|--------------------------|-----|----|------------------|-----|----|
| | | L | S | T | L | S | T |
| 00 | 0.5 | 9 | 2 | 4 | - | - | - |
| 0 | 0.5 | 11 | 2 | 7 | 16 | 2 | 7 |
| | 0.7 | 12 | 3 | 7 | 16 | 3 | 7 |
| 1 | 0.9 | 12 | 3 | 7 | 16 | 3 | 7 |
| | 0.5 | 12 | 2 | 8 | 19 | 2 | 8 |
| | 0.7 | 13 | 3 | 8 | 19 | 3 | 8 |
| | 0.9 | 13 | 3 | 8 | 19 | 3 | 8 |
| 2 | 1.3 | 13 | 3.5 | 8 | 19 | 3.5 | 8 |
| | 0.7 | 16 | 3 | 9 | 25 | 3 | 9 |
| | 0.9 | 16 | 3 | 9 | 25 | 3 | 9 |
| | 1.3 | 16 | 3.5 | 9 | 25 | 3.5 | 9 |
| | 1.6 | 18 | 4 | 9 | 25 | 4 | 9 |
| 3 | 2.0 | 18 | 4 | 9 | 25 | 4 | 9 |
| | 0.7 | 20 | 3 | 10 | 30 | 3 | 10 |
| | 0.9 | 20 | 3 | 10 | 30 | 3 | 10 |
| | 1.3 | 20 | 3.5 | 10 | 30 | 3.5 | 10 |
| | 1.6 | 22 | 4 | 10 | 30 | 4 | 10 |
| | 2.0 | 22 | 4 | 10 | 30 | 4 | 10 |

- When assembling a plug with a protective boot (#3), prep the cable by taking the protective boot and sliding it with the small inside diameter first onto the cable. Then slide the end of the back nut (#2) that has the smaller diameter onto the cable. Next, take the collet (#1) and slide the end with the gripping teeth first onto the cable until the opposite end of the collet is flush with the cut end of the jacket. If the cable has shielding, fold back the braid so that it is covering the outside diameter of the collet. Do not place braid into any area of the alignment slots. Then insure that the braid does not interfere with the alignment slots of the collet.

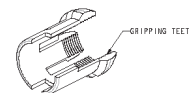
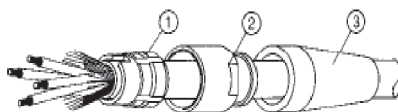

- Attach removable contacts to wires:

- If using crimped contacts, crimp the contacts onto the ends of the exposed wires using the proper crimping tool set on the correct AWG wire. (see FIGURE 4.A). After the contact has been crimped to the wire, check each contact to insure that the contact is securely crimped to the wire.

JBX Series Push-Pull Connectors



Plug assembly instructions

Figure 4.A

Locator for pin and socket 0.7 - 0.9 mm and 1.3 mm contacts

| Shell size | Ø Contact | AWG | Male contact | | | Female contact | | |
|------------|-----------|--------------|-----------------|-------------|-----------|-----------------|-------------|-----------|
| | | | SOURIAU P/N | DANIELS P/N | ASTRO P/N | SOURIAU P/N | DANIELS P/N | ASTRO P/N |
| 0 | 0.7 | 22 - 24 - 26 | JBX 0 OUT LP07 | 86 - 223 | / | JBX 0 OUT LP07 | 86 - 224 | / |
| | 0.9 | 20 - 22 - 24 | JBX 0 OUT LP09 | 86 - 225 | / | JBX 0 OUT LP09 | 86 - 226 | / |
| 1 | 0.7 | 22 - 24 - 26 | JBX 1 OUT LP07 | 86 - 196 | 642 - 001 | JBX 1 OUT LP07 | 86 - 197 | 642 - 004 |
| | 0.9 | 20 - 22 - 24 | JBX 1 OUT LP09 | 86 - 198 | 642 - 002 | JBX 1 OUT LP09 | 86 - 199 | 642 - 005 |
| | 1.3 | 18 - 20 - 22 | JBX 1 OUT LP13 | 86 - 200 | 642 - 003 | JBX 1 OUT LP13 | 86 - 201 | 642 - 006 |
| 2 | 0.7 | 22 - 24 - 26 | JBX 2 OUT LP07 | 86 - 202 | 642 - 007 | JBX 2 OUT LP07 | 86 - 203 | 642 - 010 |
| | 0.9 | 20 - 22 - 24 | JBX 2 OUT LP09 | 86 - 204 | 642 - 008 | JBX 2 OUT LP09 | 86 - 205 | 642 - 011 |
| | 1.3 | 18 - 20 - 22 | JBX 2 OUT LP13 | 86 - 206 | 642 - 009 | JBX 2 OUT LP13 | 86 - 207 | 642 - 012 |
| 3 | 0.7 | 22 - 24 - 26 | JBX 3 OUT LP07 | 86 - 217 | 642 - 014 | JBX 3 OUT LP07 | 86 - 214 | 642 - 017 |
| | 0.9 | 20 - 22 - 24 | JBX 3 OUT LP09 | 86 - 218 | 642 - 015 | JBX 3 OUT LP09 | 86 - 215 | 642 - 018 |
| | 1.3 | 18 - 20 - 22 | JBX 3 OUT LP 13 | 86 - 219 | 642 - 016 | JBX 3 OUT LP 13 | 86 - 216 | 642 - 019 |

Turret with locator for pin and socket 1.6 mm and 2 mm contacts



| Shell size | Ø Contact | AWG | Male & female contacts | | |
|------------|-----------|--------------|------------------------|-------------|-----------|
| | | | SOURIAU P/N | DANIELS P/N | ASTRO P/N |
| 2 | 1.6 | 14 - 16 - 18 | JBX 2 OUT LT16 | TH 564 | 650 - 030 |
| | 2 | 12 - 14 - 16 | JBX 2 OUT LT20 | TH 565 | 650 - 031 |
| 3 | 1.6 | 14 - 16 - 18 | JBX 3 OUT LT16 | TH 566 | 650 - 038 |
| | 2 | 12 - 14 - 16 | JBX 3 OUT LT20 | TH 567 | 650 - 035 |

Crimping tool 1.6

| Specifications MIL-C-22520 / 7.01 | | | |
|-----------------------------------|-------------------------------------|-----------------------|----------------------------------|
| | Contacts 0.7 mm - 0.9 mm and 1.3 mm | MIL P/N - SOURIAU P/N | Supplier P/N |
| | | MIL-22520/7-01 | DANIELS: MH860 |
| Specifications MIL-C-22520 / 7.01 | | | |
| | Contacts 1.6 mm and 2 mm | MIL P/N SOURIAU P/N | Supplier P/N |
| | | MIL-22520/1-01 | DANIELS: AF8 Buchanan: 615708 |

b. If using soldered contacts, prep each wire with flux and then tin dip each exposed wire end. Next pre-load a piece of heat shrink 1.6 onto the wire (Individual heat shrink tubes are optional). Solder each wire to the solder cup end of the contact. To avoid shorts, make sure that no solder comes in contact with any other contact or wire on the connector.

JBX Series Push-Pull Connectors



After the contact has been soldered to the wire, check each contact to insure that the contact is securely soldered to the wire. Slide the pre-loaded heat shrink over the solder joint and shrink into place. Do not over-heat the solder joint area as it can cause the solder to re-flow or it could burn the wire insulation.

5. If inserting removable contacts:

- a. Starting with the interface end of the contact, carefully insert each contact into the backside of the insulator that has the position loading path indicator (worm) on it. Start with the end of the position loading path indicator (worm) that has the half circle on it (Position #1). Then follow the position loading path indicator (worm) around the insulator. You will go counter clockwise if using a male contact and clockwise if using a female contact (see diagram below for the position loading path indicator (worm) layout). If the connector has center contacts, it is sometimes easier to start at the end of the position loading path indicator (worm) (last position) and work backwards. This is up to the assembler and the process they are using to insert the contacts. Make sure not to bend the contact when inserting it into the insulator. It is extremely important that the contact is completely seated in to the insulator. For the connector to function properly, the contact should click/snap into place when seated. To confirm the seating of the contact, check each contact for proper seating.

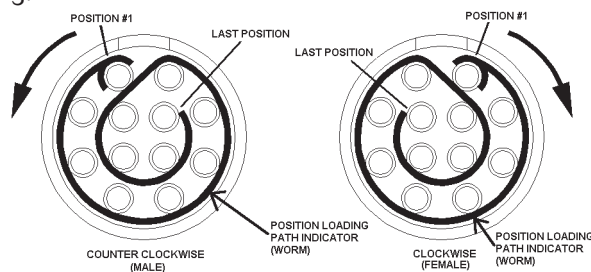

6. Removal of contacts:

- a. Using the proper extraction tool insert the tool over the front of the contact and push contact out. Failure to use the proper extraction tool can result in damage to the contact.

TOOLINGS – JBX – JKX

Manual Extraction Tools

Contacts automatically extracted without pulling on the cable.

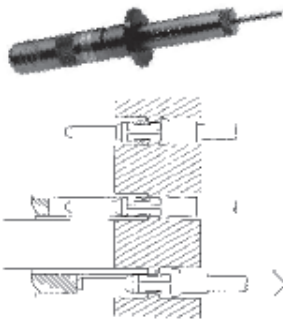

The extraction tool is the same for both male and female contacts.

| Shell size | Ø Contacts | SOURIAU part number | ASTRO part number |
|------------|------------|---------------------|-------------------|
| 0 | 0.7 | JBX OUIT DC07 | ATJP 2045 |
| | 0.9 | JBX OUIT DC09 | ATJP 2057 |
| 1 | 0.7 | JBX OUIT DC07 | ATJP 2045 |
| | 0.9 | JBX OUIT DC09 | ATJP 2057 |
| | 1.3 | JBX OUIT DC13 | ATJP 2077 |
| 2 | 0.7 | JBX OUIT DC07 | ATJP 2045 |
| | 0.9 | JBX OUIT DC09 | ATJP 2057 |
| | 1.3 | JBX OUIT DC13 | ATJP 2077 |
| | 1.6 | JBX OUIT DC16 | ATJP 2095 |
| | 2.0 | JBX OUIT DC20 | ATJP 2115 |
| 3 | 0.7 | JBX OUIT DC07 | ATJP 2045 |
| | 0.9 | JBX OUIT DC09 | ATJP 2057 |
| | 1.3 | JBX OUIT DC13 | ATJP 2077 |
| | 1.6 | JBX OUIT DC16 | ATJP 2095 |
| | 2.0 | JBX OUIT DC20 | ATJP 2115 |

7. Take the keyed half bushing (#6) and place it over the insulator so that the window is lined up with the key on the insulator and the key on the half bushing is pointing to the back of the insulator (position loading path indicator (worm end)). Then take the half bushing without the window (#6) and place on the opposite side of the insulator so that both half bushings are aligned with each other.

JBX Series Push-Pull Connectors



Plug assembly instructions

8. Take the collet that is pre-loaded on the cable and align the slots in the collet with the keys on the end of the half bushings (you may need to move the braid away from the slots and spin the collet slightly). Once they are aligned, compress the assembly so that it is in line and there are no gaps between the collet & the half bushings. The braid should still be in place once the assembly is inserted.
9. Take a connector housing (#7) and slide it over the insulator so that the red dot on the connector housing lines up with the key on the half bushing with window. Push the whole assembly into the connector housing until it bottoms out. Insure that the keys are seated properly by turning the collet that is already aligned with the half bushings. If the collet does not turn, then the keys are correctly aligned. If the collet does turn, then you must withdraw the assembly & realign the keys.

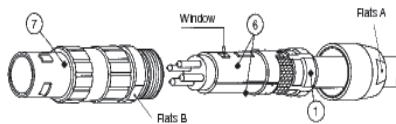

10. Once the assembly is installed into the connector housing and is aligned properly, apply thread lock to thread area. Then slide the back nut up until you can manually start the back nut threads onto the threaded end of the connector housing. Tighten the back nut up as far as you can by hand, then take the appropriate wrenches and place the wrenches onto the flats located on the connector housing. Do not over torque back nut as it can cause connector failure.
11. If the connector requires a protective boot, slide the boot over the lip on the back nut.
12. Potting of backend of plug with clipped contacts:
Clipped contacts are designed to float in the connector so that they self align when mated. It is sometimes necessary to pot the back end of the connector so that the contacts are sealed off from the environment. When this application is needed, it's recommended that the assembler engage a mating connector/alignment tool to the assembly being potted. Once the mating connector/alignment tool is engaged, it must be left engaged until the potting compound has hardened. This will insure that the true position requirements are met. If the application is for low volume, a mating connector can be used. If the application is for high volume, it is recommended that an alignment tool be purchased from the supplier..

Trouble shooting

| Problem: | Cause: | Correction: |
|--|---|--|
| Contact will not seat in connector, contact backing out. | Wrong wire or insulation size, wrong strip length, poor crimping, broken clips, damaged insulator, removed contact without proper removal tool, bad crimp. | Use correct wire, adjust strip length, strip and recrimp with the new contact, replace insulator using wrong crimp tool, replace contact |
| Bent solder contact | Bent in handling, bent in soldering operation, connector assembled incorrectly. Pins and insulator were inserted into electrical test while unprotected by shell | Replace insert with contacts |
| Connector will not release from mating part or operate correctly | Not using flats on latching sleeve and back nut to torque connector, improper assembly of the connector, over mold material inside connector | Release back-nut and re-torque, disassemble and reassemble, replace connector |
| Over tightened the back nut | Connector will not release from mating part or operate correctly, damage connector | Loosen back nut and retighten |
| Collet will not grip cable | Loose cable in connector | Check correct collet size is being used |
| Connector will not assemble | Incorrect alignment of key in connector, half bushings, connector housing, insulator, collet, braid in key slots in collet | Disassemble connector and reassemble connector-aligning keys, relocate braid in collet |
| Contact stubbing after mating | Bent contact and damaged contact, connector assembled incorrectly | Re-align contact, replace insert with contacts. |
| Electrical failure | Improper crimping, wrong wire strip length, wire loading incorrect location, poor solder joint | Remove contact with correct removal tool, reinstall new contact, and verify strip length |

JBX Series Push-Pull Connectors



Receptacle assembly instructions

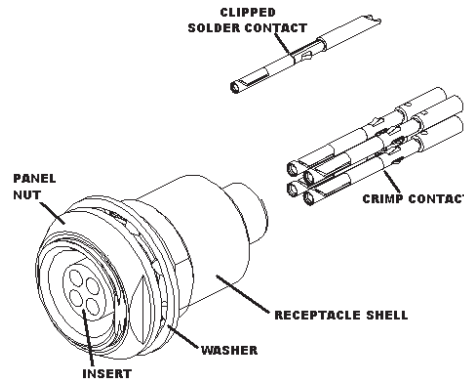

1. Select the proper JBX receptacle and contact size for the specific cable application by using the contact layout chart as depicted in the Push Pull catalog.
2. Strip the cable/wire to the required strip length.

Wiring and assembly instructions

Cable stripping for connectors with crimp contacts

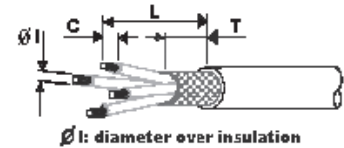

| Shell Size | Ø Contacts | Ø I | Stripping for FD, SR, PC | | | Stripping for FC | | |
|------------|------------|--------|--------------------------|-----|----|------------------|-----|----|
| | | | L | C | T | L | C | T |
| 0 | 0.7 | ≤ 1.35 | 15 | 4 | 7 | 19 | 4 | 7 |
| | | > 1.35 | | 5.5 | | | 5.5 | |
| | 0.9 | ≤ 1.6 | 15 | 4 | 7 | 19 | 4 | 7 |
| | | > 1.6 | | 5.5 | | | 5.5 | |
| 1 | 0.7 | ≤ 1.35 | 16 | 4 | 8 | 22 | 4 | 8 |
| | | > 1.35 | | 5.5 | | | 5.5 | |
| | 0.9 | ≤ 1.6 | 16 | 4 | 8 | 22 | 4 | 8 |
| | | > 1.6 | | 5.5 | | | 5.5 | |
| | 1.3 | ≤ 2.1 | 16 | 4 | 8 | 22 | 4 | 8 |
| | | > 2.1 | | 5.5 | | | 5.5 | |
| 2 | 0.7 | ≤ 1.35 | 19 | 4 | 9 | 28 | 4 | 9 |
| | | > 1.35 | | 5.5 | | | 5.5 | |
| | 0.9 | ≤ 1.6 | 19 | 4 | 9 | 28 | 4 | 9 |
| | | > 1.6 | | 5.5 | | | 5.5 | |
| | 1.3 | ≤ 2.1 | 19 | 4 | 9 | 28 | 4 | 9 |
| | | > 2.1 | | 5.5 | | | 5.5 | |
| | 1.6 | ≤ 2.6 | 21 | 5.5 | 9 | 28 | 5.5 | 9 |
| | | > 2.6 | | 7 | | | 7 | |
| 2.0 | ≤ 3.2 | 21 | 5.5 | 9 | 28 | 5.5 | 9 | |
| | > 3.2 | | 7 | | | 7 | | |
| 3 | 0.7 | ≤ 1.35 | 25 | 4 | 10 | 35 | 4 | 10 |
| | | > 1.35 | | 7 | | | 7 | |
| | 0.9 | ≤ 1.6 | 25 | 4 | 10 | 35 | 4 | 10 |
| | | > 1.6 | | 7 | | | 7 | |
| | 1.3 | ≤ 2.1 | 25 | 4 | 10 | 35 | 4 | 10 |
| | | > 2.1 | | 7 | | | 7 | |
| | 1.6 | ≤ 2.6 | 27 | 5.5 | 10 | 35 | 5.5 | 10 |
| | | > 2.6 | | 8.5 | | | 8.5 | |
| | 2.0 | ≤ 3.2 | 27 | 5.5 | 10 | 35 | 5.5 | 10 |
| | | > 3.2 | | 8.5 | | | 8.5 | |

JBX Series Push-Pull Connectors



Receptacle assembly instructions

Cable stripping for connectors with solder contacts

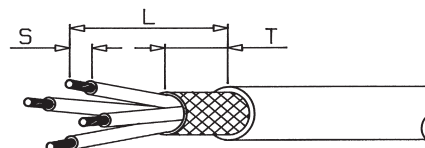

| Shell size | Ø Contact | Stripping for FD, SR, PC | | | Stripping for FC | | |
|------------|-----------|--------------------------|-----|----|------------------|-----|----|
| | | L | S | T | L | S | T |
| 00 | 0.5 | 9 | 2 | 4 | - | - | - |
| 0 | 0.5 | 11 | 2 | 7 | 16 | 2 | 7 |
| | 0.7 | 12 | 3 | 7 | 16 | 3 | 7 |
| | 0.9 | 12 | 3 | 7 | 16 | 3 | 7 |
| 1 | 0.5 | 12 | 2 | 8 | 19 | 2 | 8 |
| | 0.7 | 13 | 3 | 8 | 19 | 3 | 8 |
| | 0.9 | 13 | 3 | 8 | 19 | 3 | 8 |
| | 1.3 | 13 | 3.5 | 8 | 19 | 3.5 | 8 |
| 2 | 0.7 | 16 | 3 | 9 | 25 | 3 | 9 |
| | 0.9 | 16 | 3 | 9 | 25 | 3 | 9 |
| | 1.3 | 16 | 3.5 | 9 | 25 | 3.5 | 9 |
| | 1.6 | 18 | 4 | 9 | 25 | 4 | 9 |
| | 2.0 | 18 | 4 | 9 | 25 | 4 | 9 |
| 3 | 0.7 | 20 | 3 | 10 | 30 | 3 | 10 |
| | 0.9 | 20 | 3 | 10 | 30 | 3 | 10 |
| | 1.3 | 20 | 3.5 | 10 | 30 | 3.5 | 10 |
| | 1.6 | 22 | 4 | 10 | 30 | 4 | 10 |

3. Depending on application and shell type, the nut and washer may be removed before attaching the wires to the contacts.
4. Attach crimped contacts to wires:
 - a. If using crimped contacts, crimp the contacts onto the ends of the exposed wires using the proper crimping tool and locator set on the correct AWG wire size (see FIGURE 4.A). After the contact has been crimped to the wire, check each contact to insure that the contact is securely crimped.



Locator for pin and socket 0.7 - 0.9 mm and 1.3 mm contacts

| Shell size | Ø Contact | AWG | Male contact | | | Female contact | | |
|------------|-----------|--------------|-----------------|-------------|-----------|-----------------|-------------|-----------|
| | | | SOURIAU P/N | DANIELS P/N | ASTRO P/N | SOURIAU P/N | DANIELS P/N | ASTRO P/N |
| 0 | 0.7 | 22 - 24 - 26 | JBX 0 OUT LP07 | 86 - 223 | / | JBX 0 OUT LP07 | 86 - 224 | / |
| | 0.9 | 20 - 22 - 24 | JBX 0 OUT LP09 | 86 - 225 | / | JBX 0 OUT LP09 | 86 - 226 | / |
| 1 | 0.7 | 22 - 24 - 26 | JBX 1 OUT LP07 | 86 - 196 | 642 - 001 | JBX 1 OUT LP07 | 86 - 197 | 642 - 004 |
| | 0.9 | 20 - 22 - 24 | JBX 1 OUT LP09 | 86 - 198 | 642 - 002 | JBX 1 OUT LP09 | 86 - 199 | 642 - 005 |
| | 1.3 | 18 - 20 - 22 | JBX 1 OUT LP13 | 86 - 200 | 642 - 003 | JBX 1 OUT LP13 | 86 - 201 | 642 - 006 |
| 2 | 0.7 | 22 - 24 - 26 | JBX 2 OUT LP07 | 86 - 202 | 642 - 007 | JBX 2 OUT LP07 | 86 - 203 | 642 - 010 |
| | 0.9 | 20 - 22 - 24 | JBX 2 OUT LP09 | 86 - 204 | 642 - 008 | JBX 2 OUT LP09 | 86 - 205 | 642 - 011 |
| | 1.3 | 18 - 20 - 22 | JBX 2 OUT LP13 | 86 - 206 | 642 - 009 | JBX 2 OUT LP13 | 86 - 207 | 642 - 012 |
| 3 | 0.7 | 22 - 24 - 26 | JBX 3 OUT LP07 | 86 - 217 | 642 - 014 | JBX 3 OUT LP07 | 86 - 214 | 642 - 017 |
| | 0.9 | 20 - 22 - 24 | JBX 3 OUT LP09 | 86 - 218 | 642 - 015 | JBX 3 OUT LP09 | 86 - 215 | 642 - 018 |
| | 1.3 | 18 - 20 - 22 | JBX 3 OUT LP 13 | 86 - 219 | 642 - 016 | JBX 3 OUT LP 13 | 86 - 216 | 642 - 019 |

JBX Series Push-Pull Connectors



Turret with locator for pin and socket 1.6 mm and 2 mm contacts

Figure 4.A

| Shell size | Ø Contact | AWG | Male & female contacts | | |
|------------|-----------|--------------|------------------------|-------------|-----------|
| | | | SOURIAU P/N | DANIELS P/N | ASTRO P/N |
| 2 | 1.6 | 14 - 16 - 18 | JBX 2 OUT LT16 | TH 564 | 650 - 030 |
| | 2 | 12 - 14 - 16 | JBX 2 OUT LT20 | TH 565 | 650 - 031 |
| 3 | 1.6 | 14 - 16 - 18 | JBX 3 OUT LT16 | TH 566 | 650 - 038 |
| | 2 | 12 - 14 - 16 | JBX 3 OUT LT20 | TH 567 | 650 - 035 |

Crimping tool

| Specifications MIL-C-22520 / 7.01 | | | |
|-----------------------------------|-------------------------------------|-----------------------|----------------------------------|
| | Contacts 0.7 mm - 0.9 mm and 1.3 mm | MIL P/N - SOURIAU P/N | Supplier P/N |
| | | MIL-22520/7-01 | DANIELS: MH860 |
| Specifications MIL-C-22520 / 7.01 | | | |
| | Contacts 1.6 mm and 2 mm | MIL P/N SOURIAU P/N | Supplier P/N |
| | | MIL-22520/1-01 | DANIELS: AF8 Buchanan: 615708 |

b. If using clipped solder contacts, prep each wire with flux and then tin dip each exposed wire end. Next pre-load a piece of heat shrink onto the wire (Individual heat shrink tubes are optional). Solder each wire to the solder cup end of the contact. To avoid shorts, make sure that no solder comes in contact with any other contact or wire on the connector. After the contact has been soldered to the wire, check each contact to insure that the contact is securely soldered to the wire. Slide the pre-loaded heat shrink over the solder joint and shrink into place. Do not over-heat the solder joint area as it can cause the solder to re-flow or it could burn the wire insulation.

5. If inserting terminated contacts:

a. Starting with the interface end of the contact, insert each contact into the backside of the insulator that has the position loading path indicator (worm) on it. Start with the end of the position loading path indicator (worm) that has the half circle on it (Position #1). Then follow the position loading path indicator (worm) around the insulator. You will go counter clockwise if using a male contact and clockwise if using a female contact (see diagram below for the position loading path indicator (worm) layout). If the connector has center contacts, it is some times easier to start at the end of the position loading path indicator (worm) (last position) and work backwards. This is up to the assembler and the process used to insert the contacts. Make sure not to bend the contact when inserting it into the insulator. It is extremely important that the contact is seated in the insulator for the connector to function properly. The contact should click/snap into place when seated. Check each contact for proper seating.

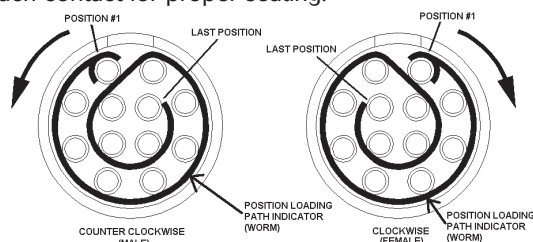

6. Removal of contacts:

Using the proper extraction tool (See FIGURE 6.A), insert the tool over the front of the contact and push contact out. Failure to use the proper extraction tool can result in damage to the contact.

JBX Series Push-Pull Connectors



Receptacle assembly instructions

Manual extraction tool

The extraction tool is the same for both male and female contacts.

Figure 6.A



| Shell size | Ø contacts | SOURIAU part number | ASTRO part number |
|------------|------------|---------------------|-------------------|
| 0 | 0.7 | JBX OUT DC 07 | ATJP 2045 |
| | 0.9 | JBX OUT DC 09 | ATJP 2057 |
| 1 | 0.7 | JBX OUT DC 07 | ATJP 2045 |
| | 0.9 | JBX OUT DC 09 | ATJP 2057 |
| | 1.3 | JBX OUT DC 13 | ATJP 2077 |
| 2 | 0.7 | JBX OUT DC 07 | ATJP 2045 |
| | 0.9 | JBX OUT DC 09 | ATJP 2057 |
| | 1.3 | JBX OUT DC 13 | ATJP 2077 |
| | 1.6 | JBX OUT DC 16 | ATJP 2095 |
| 3 | 2.0 | JBX OUT DC 20 | ATJP 2115 |
| | 0.7 | JBX OUT DC 07 | ATJP 2045 |
| | 0.9 | JBX OUT DC 09 | ATJP 2057 |
| | 1.3 | JBX OUT DC 13 | ATJP 2077 |
| | 1.6 | JBX OUT DC 16 | ATJP 2095 |
| | 2.0 | JBX OUT DC 20 | ATJP 2115 |

7. Potting of backend of receptacle with clipped contacts

Clipped contacts are designed to float in the connector so that they self align when mated. It is sometimes necessary to pot the backend of the connector so that the contacts are sealed off from the environment. When this application is needed, it is recommended that the assembler engage a mating connector/alignment tool to the assembly being potted. Once the mating connector/alignment tool is engaged, it must be left engaged until the potting compound has hardened. This will insure that the true position requirements are met. If the application is low volume, a mating connector can be used. If the application is for high volume, it is recommended that an alignment tool be purchased from the supplier.

Trouble shooting

| Problem: | Cause: | Correction: |
|--|--|--|
| Contact will not seat in connector, contact backing out. | Wrong wire or insulation size, wrong strip length, poor crimping, broken clips, damaged insulator, removed contact without proper removal tool, bad crimp. | Use correct wire, adjust strip length, strip and recrimp with new contact, replace insulator, using correct crimp tool, replace contact. |
| Bent solder contact. | Bent in handling, bent in soldering operation, connector assembled incorrectly. | Re-align contact, replace insert with contacts. |
| Contact stubbing after mating. | Bent contact and damaged contact, connector assembled incorrectly. | Re-align contact, replace insert with contacts. If using clipped contacts and receptacle is potted, a mating connector must be applied to the connector that is being potted. This insures that contacts will be properly aligned. |
| Electrical failure | Improper crimping, wrong wire strip length, wire loading incorrect location, poor solder joint. | Remove contact with correct removal tool, reinstall new contact, and verify strength. |

JBX Sealed Series Push-Pull Connectors



Major features & benefits

Key features

- Sealed IP 67 (mated connectors) (FE, EC, SE & PE)
- Watertight receptacles IP68 (HC, HG, HH & HM)
- Mechanically keyed : ensure correct polarisation and alignment.
- Contact arrangements : from 2 to 19 contacts.
- Wire gauge range from 26 AWG to 12 AWG.
- High contact density in a small space.
- Contact termination in either crimp, solder or PCB contacts.



User advantages

Wet environment
Splash proof IP 67



6-collet cluster
Allows a wide range of cable diameter applications for a single connector.

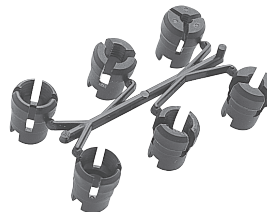

Removable contacts
Crimp versions allow easier wiring and maintenance.

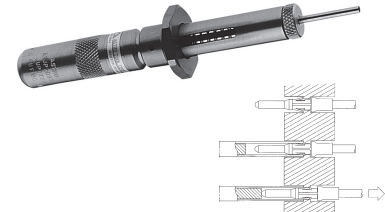

Part number system

| | | | | | | | | | | | | |
|-----------------------|---|----|---|---|----|---|---|---|---|---|---|---|
| Basic series | JBX | FD | 2 | G | 05 | M | C | S | D | S | M | R |
| Shell type-Receptacle | EC - HC - HG - HH - HM - PE - SE | | | | | | | | | | | |
| Shell type - Plug | FE | | | | | | | | | | | |
| Shell size | 0 - 1 - 2 | | | | | | | | | | | |
| Keying | G - J - A - B | | | | | | | | | | | |
| Contact layout | 02 ----- 30 | | | | | | | | | | | |
| Contact type | M : pin F : socket (in relation with keying) | | | | | | | | | | | |
| Contact termination | C: crimp; S: solder; P*: straight PCB tails ; Q*: Right Angle PCB tails | | | | | | | | | | | |
| Surface plating | S: Outer shell brass alloy chrome over nickel plating N: Outer shell in brass alloy with black plating (consult SOURIAU USA) | | | | | | | | | | | |
| Obligatory Suffix | D: For all part numbers | | | | | | | | | | | |
| Contact Size | S: All contact diameters except .05 mm P: 0.5 mm contact dimensions only | | | | | | | | | | | |
| Cable Backnut Option | M: Connector with backnut for protective boot - Protective boot to order separately page 13 | | | | | | | | | | | |
| Key Identifier | R: Red dot on shell for HG, HH, PE, FF only | | | | | | | | | | | |

* For receptacles with female contacts only.

JBX Sealed Series Push-Pull Connectors



Sealed Shell Types

EC : Double Nut Panel Receptacle

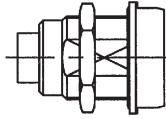

PE : In Line Receptacle

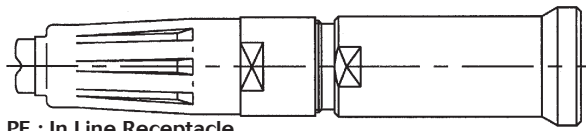

SE : Sealed Panel Mount Cable Receptacle

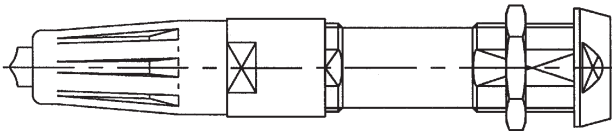

HC : Rear Mount Receptacle

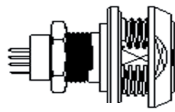

HG : Front Mount Receptacle

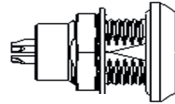

HH : Front Mount Receptacle

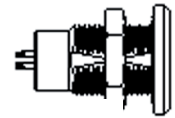

HM : Rear Mount Receptacle

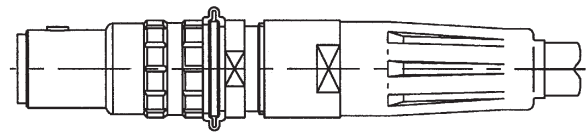
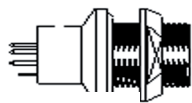

FE : Straight plug with cable clamping

JBX Sealed Series Push-Pull Connectors



Dimensions (mm)

EC : Sealed Double Nut Panel Receptacle

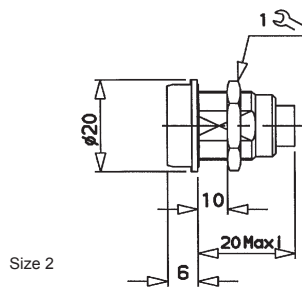

HC : Sealed Rear Mount Receptacle

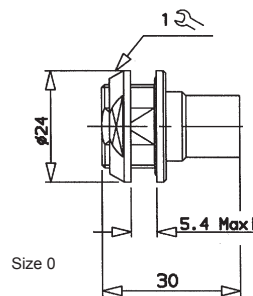

PE : Sealed In Line Receptacle

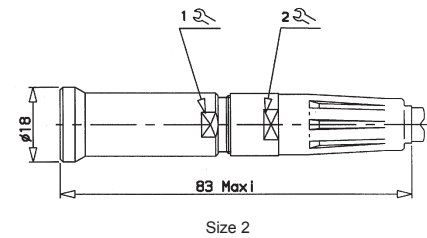

SE : Sealed Sealed Panel Mount
Cable Receptacle

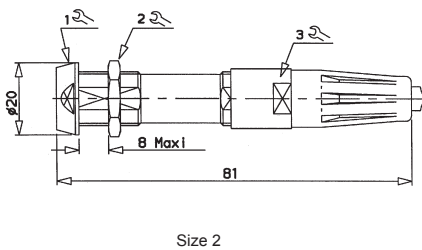

HG : Sealed Front Mount Receptacle

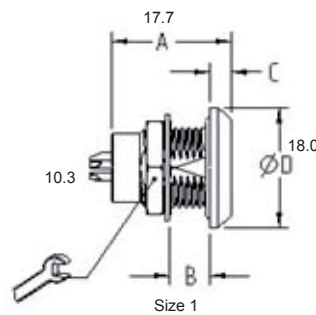

HH : Sealed Front Mount Receptacle

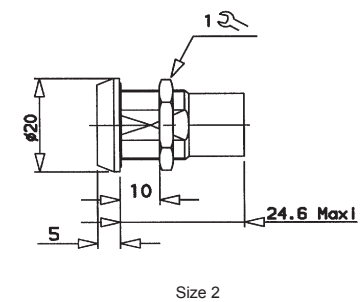

FE : Sealed Straight Plug with cable clamping

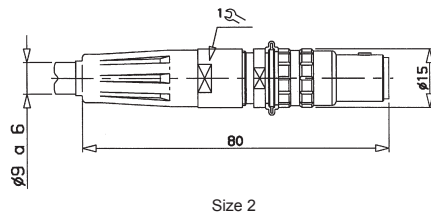

HM : Sealed Rear Mount Receptacle

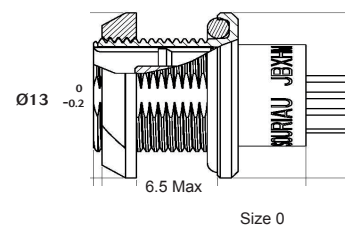

Available shell size/styles:

| Shell size | FE | EC | HC | HG | HH* | HM** | PE | SE |
|------------|----|----|----|----|-----|------|----|----|
| 0 | O | O | ● | O | O | ● | O | O |
| 1 | O | O | O | ● | O | O | O | O |
| 2 | ● | ● | ● | O | ● | O | ● | ● |

* HH also available in shell size 00 - Consult factory

** HM also available in shell size 1 - Consult factory

● Available for JBX Series - O Contact SOURIAU for additional shell styles and sizes -

Note 1 : For the plug, the in line receptacle and the panel mount cable receptacle, a black protective boot is included in the P/N.

JBX Sealed Series Push-Pull Connectors



Keying

Only G keying is available in standard version (0° keying angle, plugs with pin contacts, receptacles with female contacts) for the different types of shells.

Contact layouts Multi contact inserts

| Shell size 0 | | | | | | | |
|----------------------------|---------|---------|----------|---------|---------|---------|---------|
| | 02 | 03 | 04 | 05 | 06 | 07 | 08 |
| Male insulator wire side | | | | | | | |
| Solder | S | S | S** | S** | S** | S** | S** |
| Crimp | C | C | C | C | | | |
| PCB straight tails* | P* | P* | P* | P* | P* | P* | P* |
| PCB right angles* | Q* | Q* | Q* | Q* | | | |
| Contact diameter mm | 0.9 | 0.9 | 0.7 | 0.7 | 0.5 | 0.5 | 0.5 |
| Solder Max. AWG | 24 | 24 | 26 | 26 | 28 | 28 | 28 |
| Crimp wire Max. AWG | 20 | 20 | 22 | 22 | | | |
| Max current rating | 10 | 8 | 7 | 6.5 | 2.5 | 2.5 | 2 |
| Test voltage (Vrms) | 1400 | 1300 | 1350 | 800 | 680 | 680 | 680 |
| Working Voltage (Vdc/Vrms) | 600/460 | 600/420 | 660/4205 | 400/220 | 320/220 | 320/220 | 320/220 |

| Shell size 1 | | | | | | | | | |
|----------------------------|---------|---------|---------|---------|---------|---------|---------|---------|---------|
| | 02 | 03 | 04 | 05 | 06 | 07 | 08 | 10 | 12 |
| Male insulator wire side | | | | | | | | | |
| Solder | S | S | S | S | S** | S** | S** | S** | S** |
| Crimp | C | C | C | C | C | C | C | | |
| PCB straight tails* | P* | P* | P* | P* | P* | P* | P* | P* | P* |
| PCB right angles* | | Q* | Q* | Q* | Q* | Q* | Q* | | |
| Contact diameter mm | 1.3 | 1.3 | 0.9 | 0.9 | 0.7 | 0.7 | 0.7 | 0.5 | 0.5 |
| Solder Max. AWG | 20 | 20 | 24 | 24 | 26 | 26 | 26 | 28 | 28 |
| Crimp wire Max. AWG | 18 | 18 | 20 | 20 | 22 | 22 | 22 | | |
| Max current rating | 15 | 12 | 10 | 9 | 7 | 7 | 5 | 2.5 | 2.5 |
| Test voltage (Vrms) | 1600 | 1300 | 1900 | 1400 | 1400 | 1400 | 1200 | 600 | 500 |
| Working Voltage (Vdc/Vrms) | 760/530 | 600/420 | 900/630 | 660/460 | 600/460 | 600/460 | 600/420 | 300/200 | 275/175 |

**Inserts with fixed non removable contacts

* For receptacles with female contacts.

Note : Contact numbering mating faces receptacle view: counterclockwise from key at position 1

Contact numbering mating faces plug view: clockwise from key at position 1

JBX Sealed Series Push-Pull Connectors



Contact layouts

| Shell size 2 | | | | | | | |
|----------------------------|----------|---------|----------|---------|---------|---------|---------|
| | 02 | 03 | 04 | 05 | 06 | 07 | 08 |
| Male insulator wire side | | | | | | | |
| Solder | S | S | S | S | S | S | S |
| Crimp | C | C | C | C | C | C | C |
| PCB straight tails* | | | P* | P* | P* | P* | P* |
| PCB right angles* | | | Q* | Q* | Q* | Q* | Q* |
| Contact diameter mm | 2.0 | 1.6 | 1.3 | 1.3 | 1.3 | 1.3 | 0.9 |
| Solder Max. AWG | 16 | 18 | 20 | 20 | 20 | 20 | 24 |
| Crimp wire Max. AWG | 12 | 14 | 18 | 18 | 18 | 18 | 20 |
| Max current rating | 30 | 17 | 15 | 14 | 12 | 11 | 10 |
| Test voltage (Vrms) | 2100 | 1700 | 2400 | 1900 | 1900 | 1500 | 1700 |
| Working Voltage (Vdc/Vrms) | 1000/700 | 830/560 | 1000/800 | 900/630 | 900/630 | 730/500 | 830/560 |

| Shell size 2 | | | | | |
|----------------------------|---------|---------|---------|---------|---------|
| | 10 | 12 | 16 | 18 | 19 |
| Male insulator wire side | | | | | |
| Solder | S | SXX | SXX | SXX | SXX |
| Crimp | C | C | C | C | C |
| PCB straight tails* | P* | P* | P* | P* | P* |
| PCB right angles* | Q* | Q* | Q* | | |
| Contact diameter mm | 0.9 | 0.7 | 0.7 | 0.7 | 0.7 |
| Solder Max. AWG | 24 | 26 | 26 | 26 | 26 |
| Crimp wire Max. AWG | 20 | 22 | 22 | 22 | 22 |
| Max current rating | 8 | 7 | 6 | 5.5 | 5 |
| Test voltage (Vrms) | 1700 | 1700 | 1500 | 1400 | 1400 |
| Working Voltage (Vdc/Vrms) | 830/560 | 830/560 | 730/500 | 660/460 | 660/460 |

**Inserts with fixed non removable contacts * For receptacles with female contacts.

Note : Contact numbering mating faces receptacle view: counterclockwise from key at position 1
Contact numbering mating faces plug view: clockwise from key at position 1



JBX Sealed Series Push-Pull Connectors

Technical characteristics

The technical characteristics are the same as for the standard JBX series except the following ones:

Material specifications

| Component | Material | Color | Working temperatures | |
|-----------------|-------------------------|-------------------------------------|----------------------|--------------------|
| Seals | Nitril & Silicon rubber | O'ring = black Plug seal = black | -40° C; +250° C | - 58° F; + 482 ° F |
| Protective boot | Elastolan (UPR) | Black | -40° C; +80° C | - 40° F; + 176 ° F |

Mechanical and environmental control specifications

| Characteristics | Values | |
|------------------------|---|--------------------|
| Protection Index | IP 67 (splashproof - 1/2 hour under 1 m of water) | |
| Operating temperatures | -40° C; +80° C | - 40° F; + 176 ° F |

Options

Receptacle Cap: maintain IP67 rating
Size 2 Part-number = JBX BR2022

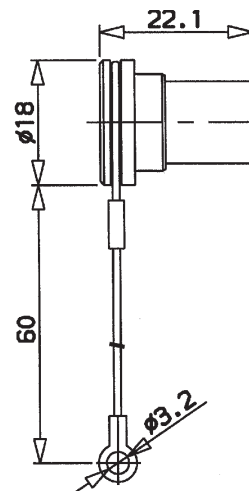

Wiring and assembly instructions

Panel cutout

The panel cutout is the same as for the JBX size 2 shells except for the HC type for which it corresponds to the JBX size 3 shells.

Range of cable diameter: from 6 to 9 mm

Operation to add during the plug assembly:

Deposit of watertight thread glue between the backnut ② on the drawing p19) and the connection shell ⑦ on the drawing p19).

Advised glue = Loctite 542.

JBX Series Push-Pull Connectors



Accessories JBX

Insulating washer

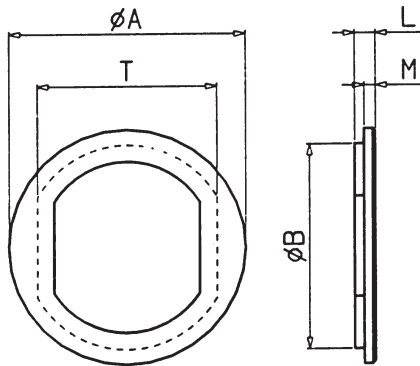

| Part Number | Shell size | Ø A | B | L | M | N | T | E |
|-------------|------------|-----|------|-----|-----|-----|------|------|
| JBX 00 RIN | 00 | 10 | 8.8 | 1.8 | 1 | 0.8 | 8 | 4.4 |
| JBX 0 RI* | 0 | 12 | 10.8 | 1.8 | 1 | 0.8 | 9.9 | 6.4 |
| JBX 1 RI* | 1 | 16 | 13.8 | 1.8 | 1 | 0.8 | 12.2 | 8.4 |
| JBX 2 RI* | 2 | 21 | 17.8 | 2.2 | 1.2 | 0.8 | 16.2 | 8.2 |
| JBX 3 RI* | 3 | 25 | 21.8 | 2.2 | 1.2 | 0.8 | 20.2 | 10.1 |

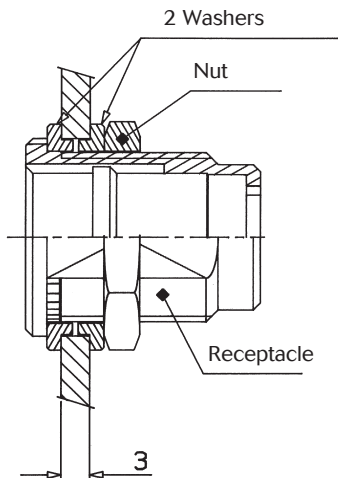

Material : PA 6/6

Working temperature : - 40°C ; + 125°C
- 40°F ; + 257°F

| Color code | Colors |
|------------|--------|
| A | blue |
| B | white |
| G | grey |
| J | yellow |
| M | brown |
| N | black |
| R | red |
| V | green |
| O | orange |

Using 2 washers for receptacle / panel insulating

For use with JBX only, not sealed JBX or JKX

Grounding washer

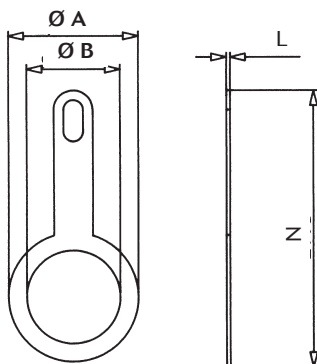

| Part Number | Shell size | Dimensions | | | |
|---------------|------------|------------|------|-----|------|
| | | Ø A | Ø B | L | N |
| JAX RA 00 251 | 00 | 9.5 | 7.1 | 0.4 | 18.2 |
| JAX RA 0 251 | 0 | 13 | 9.1 | 0.4 | 22 |
| JAX RA 1 251 | 1 | 17 | 12.2 | 0.5 | 27.5 |
| JAX RA 2 251 | 2 | 20 | 15.2 | 0.5 | 32 |
| JAX RA 3 251 | 3 | 25 | 18.2 | 0.5 | 39 |

Material : - Brass
- Copper, Tin, Zinc plated Brass (2 mm)

For use with JBX only, not sealed JBX or JKX

JBX Series Push-Pull Connectors



Accessories JBX

Locking washer

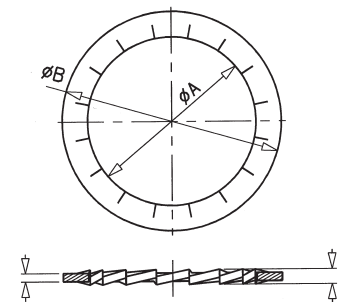

| Part Number | Shell size | Dimensions | | | |
|-------------|------------|------------|------|-----|---|
| | | Ø A | Ø B | C | D |
| JAX RE 00 | 00 | 7.3 | 10 | 0.5 | 1 |
| JAX RE 0 | 0 | 9.2 | 12.5 | 0.6 | 1 |
| JAX RE 1 | 1 | 12.2 | 16 | 0.6 | 1 |

Piece part JBX

Crimp contacts (if ordered separately)

| Shell size | Ø Contact | Part number | |
|------------|-----------|----------------|----------------|
| | | Crimp pin | Crimp socket |
| 0 | 0.9 | JBX 0 CT MC 09 | JBX 0 CT FC 09 |
| | 0.7 | JBX 0 CT MC 07 | JBX 0 CT FC 07 |
| 1 | 1.3 | JBX 1 CT MC 13 | JBX 1 CT FC 13 |
| | 0.9 | JBX CT 1 MC 09 | JBX 1 CT FC 09 |
| | 0.7 | JBX CT 1 MC 07 | JBX 1 CT FC 07 |
| 2 | 2 | JBX 2 CT MC 20 | JBX 2 CT FC 20 |
| | 1.6 | JBX 2 CT MC 16 | JBX 2 CT FC 16 |
| | 1.3 | JBX 2 CT MC 13 | JBX 2 CT FC 13 |
| | 0.9 | JBX 2 CT MC 09 | JBX 2 CT FC 09 |
| | 0.7 | JBX 2 CT MC 07 | JBX 2 CT FC 07 |
| 3 | 2 | JBX 3 CT MC 20 | JBX 3 CT FC 20 |
| | 1.6 | JBX 3 CT MC 16 | JBX 3 CT FC 16 |
| | 1.3 | JBX 3 CT MC 13 | JBX 3 CT FC 13 |
| | 0.9 | JBX 3 CT MC 09 | JBX 3 CT FC 09 |
| | 0.7 | JBX 3 CT MC 07 | JBX 3 CT FC 07 |

Solder contacts (if ordered separately)

| Shell size | Ø Contact | Part number | |
|------------|-----------|----------------|----------------|
| | | Solder pin | Solder socket |
| 0 | 0.9 | JBX 0 CT MS 09 | JBX 0 CT FS 09 |
| 1 | 1.3 | JBX 1 CT MS 13 | JBX 1 CT FS 13 |
| | 0.9 | JBX 1 CT MS 09 | JBX 1 CT FS 09 |
| 2 | 2 | JBX 2 CT MS 20 | JBX 2 CT FS 20 |
| | 1.6 | JBX 2 CT MS 16 | JBX 2 CT FS 16 |
| | 1.3 | JBX 2 CT MS 13 | JBX 2 CT FS 13 |
| | 0.9 | JBX 2 CT MS 09 | JBX 2 CT FS 09 |
| 3 | 2 | JBX 3 CT MS 20 | JBX 3 CT FS 20 |
| | 1.6 | JBX 3 CT MS 16 | JBX 3 CT FS 16 |
| | 1.3 | JBX 3 CT MS 13 | JBX 3 CT FS 13 |
| | 0.9 | JBX 3 CT MS 09 | JBX 3 CT FS 09 |

Solder contacts of 0.5 mm and 0.7 mm of diameter not available separately (always fixed into the insulator)

JBX Series Push-Pull Connectors



Piece parts JBX

Inserts for removable solder and crimp contacts (if ordered separately)

| Shell size | Insert | Insert part number | |
|------------|--------|--------------------|-----------------|
| | | Pin contact | Socket contacts |
| 0 | 02 | JBX 0 BI 02 MS | JBX 0 BI 02 FS |
| | 03 | JBX 0 BI 03 MS | JBX 0 BI 03 FS |
| | 04 | JBX 0 BI 04 MS | JBX 0 BI 04 FS |
| | 05 | JBX 0 BI 05 MS | JBX 0 BI 05 FS |
| 1 | 02 | JBX 1 BI 02 MS | JBX 1 BI 02 FS |
| | 03 | JBX 1 BI 03 MS | JBX 1 BI 03 FS |
| | 04 | JBX 1 BI 04 MS | JBX 1 BI 04 FS |
| | 05 | JBX 1 BI 05 MS | JBX 1 BI 05 FS |
| | 06 | JBX 1 BI 06 MS | JBX 1 BI 06 FS |
| | 07 | JBX 1 BI 07 MS | JBX 1 BI 07 FS |
| | 08 | JBX 1 BI 08 MS | JBX 1 BI 08 FS |
| | 2 | 02 | JBX 2 BI 02 MS |
| 03 | | JBX 2 BI 03 MS | JBX 2 BI 03 FS |
| 04 | | JBX 2 BI 04 MS | JBX 2 BI 04 FS |
| 05 | | JBX 2 BI 05 MS | JBX 2 BI 05 FS |
| 06 | | JBX 2 BI 06 MS | JBX 2 BI 06 FS |
| 07 | | JBX 2 BI 07 MS | JBX 2 BI 07 FS |
| 08 | | JBX 2 BI 08 MS | JBX 2 BI 08 FS |
| 10 | | JBX 2 BI 10 MS | JBX 2 BI 10 FS |
| 12 | | JBX 2 BI 12 MS | JBX 2 BI 12 FS |
| 16 | | JBX 2 BI 16 MS | JBX 2 BI 16 FS |
| 18 | | JBX 2 BI 18 MS | JBX 2 BI 18 FS |
| 3 | 03 | JBX 3 BI 03 MS | JBX 3 BI 03 FS |
| | 04 | JBX 3 BI 04 MS | JBX 3 BI 04 FS |
| | 07 | JBX 3 BI 07 MS | JBX 3 BI 07 FS |
| | 10 | JBX 3 BI 10 MS | JBX 3 BI 10 FS |
| | 14 | JBX 3 BI 14 MS | JBX 3 BI 14 FS |
| | 18 | JBX 3 BI 18 MS | JBX 3 BI 18 FS |
| | 22 | JBX 3 BI 22 MS | JBX 3 BI 22 FS |
| | 30 | JBX 3 BI 30 MS | JBX 3 BI 30 FS |



Inserts with fixed solder contacts (if ordered separately)

| Shell size | Insert | Insert part number | |
|------------|--------|--------------------|------------------|
| | | Pin contacts | Socket contacts |
| 00 | 04 | JBX 00 BI 04 MPS | JBX 00 BI 04 FPS |
| 0 | 04 | JBX 0 BI 04 MSS | JBX 0 BI 04 FSS |
| | 05 | JBX 0 BI 05 MSS | JBX 0 BI 05 FSS |
| | 06 | JBX 0 BI 06 MPS | JBX 0 BI 06 FPS |
| | 07 | JBX 0 BI 07 MPS | JBX 0 BI 07 FPS |
| 1 | 07 | JBX 1 BI 07 MSS | JBX 1 BI 07 FSS |
| | 08 | JBX 1 BI 08 MSS | JBX 1 BI 08 FSS |
| | 10 | JBX 1 BI 10 MPS | JBX 1 BI 10 FPS |
| 2 | 12 | JBX 2 BI 12 MSS | JBX 2 BI 12 FSS |
| | 16 | JBX 2 BI 16 MSS | JBX 2 BI 16 FSS |
| | 18 | JBX 2 BI 18 MSS | JBX 2 BI 18 FSS |
| | 19 | JBX 2 BI 19 MSS | JBX 2 BI 19 FSS |
| 3 | 22 | JBX 3 BI 22 MSS | JBX 3 BI 22 FSS |
| | 30 | JBX 3 BI 30 MSS | JBX 3 BI 30 FSS |



JBX Series Push-Pull Connectors



JBX PCB Layout Patterns - Angular Patterns

| Shell size 0 | | | | | | |
|--------------------------|------|------|------|-------|-----|-----|
| | 02 | 03 | 04 | 05 | 06 | 07 |
| Male insulator wire side | | | | | | |
| R1 (mm) | 1.10 | 1.15 | 1.25 | 1.375 | 1.5 | 1.5 |
| R2 (mm) | -- | -- | -- | -- | -- | -- |

| Shell size 1 | | | | | | | | |
|--------------------------|------|------|------|------|------|------|------|------|
| | 02 | 03 | 04 | 05 | 06 | 07 | 08 | 10 |
| Male insulator wire side | | | | | | | | |
| R1 (mm) | 1.40 | 1.50 | 1.55 | 1.70 | 1.85 | 1.85 | 1.85 | 2.00 |
| R2 (mm) | -- | -- | -- | -- | -- | -- | -- | 0.70 |

| Shell size 2 | | | | | | | | | |
|--------------------------|------|------|------|------|------|------|------|------|------|
| | 02 | 03 | 04 | 05 | 06 | 07 | 08 | 10 | 12 |
| Male insulator wire side | | | | | | | | | |
| R1 (mm) | 2.20 | 2.30 | 2.45 | 2.55 | 2.75 | 2.88 | 3.15 | 3.15 | 3.23 |
| R2 (mm) | -- | -- | -- | -- | -- | -- | -- | 1.10 | 1.40 |

| Shell size 3 | | | | | | | |
|--------------------------|------|------|------|------|------|------|------|
| | 03 | 04 | 07 | 08 | 10 | 14 | 18 |
| Male insulator wire side | | | | | | | |
| R1 (mm) | 2.75 | 3.10 | 3.50 | 3.75 | 3.90 | 4.05 | 4.15 |
| R2 (mm) | -- | -- | -- | -- | 1.40 | 1.70 | 2.15 |

Notes:

1. All dimensions are ± 0.05
2. Layouts are shown from the mating face of the female insulator.
3. Coordinate layouts are on page

| Contact PCB Tail Size \varnothing (mm) | Recommended Finished PCB Hole Size \varnothing (mm) |
|---|--|
| 0.5 | 0.75 |
| 0.7 | 0.95 |
| 0.9 | 1.15 |
| 1.3 | 1.55 |

JBX Series Push-Pull Connectors



JBX PCB Layout Patterns - Coordinate Patterns

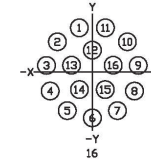
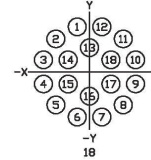
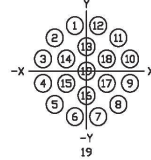
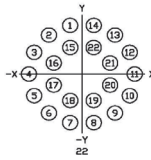
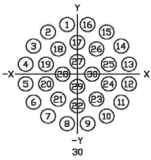

| 30 | | |
|-----|-------|-------|
| PDS | X | Y |
| 1 | -0.87 | 4.38 |
| 2 | -2.48 | 3.72 |
| 3 | -3.72 | 2.48 |
| 4 | -4.38 | 0.87 |
| 5 | -4.38 | -0.87 |
| 6 | -3.72 | -2.48 |
| 7 | -2.48 | -3.72 |
| 8 | -0.87 | -4.38 |
| 9 | 0.87 | 4.38 |
| 10 | 2.48 | -3.72 |
| 11 | 3.72 | -2.48 |
| 12 | 4.38 | -0.87 |
| 13 | 4.38 | 0.87 |
| 14 | 3.72 | 2.48 |
| 15 | 2.48 | 3.72 |
| 16 | 0.87 | 4.38 |
| 17 | 0 | 2.80 |
| 18 | -1.62 | 2.22 |
| 19 | -2.66 | 0.87 |
| 20 | -2.66 | -0.87 |
| 21 | -1.62 | -2.22 |
| 22 | 0 | -2.80 |
| 23 | 1.62 | -2.22 |
| 24 | 2.66 | -0.87 |
| 25 | 2.66 | 0.87 |
| 26 | 1.62 | 2.22 |
| 27 | 0 | 1.10 |
| 28 | -1.25 | 0 |
| 29 | 0 | -1.10 |
| 30 | 1.25 | 0 |

| 22 | | |
|-----|-------|-------|
| PDS | X | Y |
| 1 | -0.97 | 4.24 |
| 2 | -2.71 | 3.40 |
| 3 | -3.92 | 1.89 |
| 4 | -4.35 | 0 |
| 5 | -3.92 | -1.89 |
| 6 | -2.71 | -3.40 |
| 7 | -0.97 | -4.24 |
| 8 | 0.97 | -4.24 |
| 9 | 2.71 | -3.40 |
| 10 | 3.92 | -1.89 |
| 11 | 4.35 | 0 |
| 12 | 3.92 | 1.89 |
| 13 | 2.71 | 3.40 |
| 14 | 0.97 | 4.24 |
| 15 | -0.96 | 2.31 |
| 16 | -2.31 | 0.96 |
| 17 | -2.31 | -0.96 |
| 18 | -0.96 | -2.31 |
| 19 | 0.96 | -2.31 |
| 20 | 2.31 | -0.96 |
| 21 | 2.31 | 0.96 |
| 22 | 0.96 | 2.31 |

| 19 | | |
|-----|--------|--------|
| PDS | X | Y |
| 1 | -0.861 | 3.212 |
| 2 | -2.351 | 2.351 |
| 3 | -3.212 | 0.861 |
| 4 | -3.212 | -0.861 |
| 5 | -2.351 | -2.351 |
| 6 | -0.861 | -3.212 |
| 7 | 0.861 | -3.212 |
| 8 | 2.351 | -2.351 |
| 9 | 3.212 | -0.861 |
| 10 | 3.212 | 0.861 |
| 11 | 2.351 | 2.351 |
| 12 | 0.861 | 3.212 |
| 13 | 0 | 1.725 |
| 14 | -1.494 | 0.862 |
| 15 | -1.494 | -0.862 |
| 16 | 0 | -1.725 |
| 17 | 1.494 | -0.862 |
| 18 | 1.494 | 0.862 |
| 19 | 0 | 0 |

| 18 | | |
|-----|--------|--------|
| PDS | X | Y |
| 1 | -0.861 | 3.212 |
| 2 | -2.351 | 2.351 |
| 3 | -3.212 | 0.861 |
| 4 | -3.212 | -0.861 |
| 5 | -2.351 | -2.351 |
| 6 | -0.861 | -3.212 |
| 7 | 0.861 | -3.212 |
| 8 | 2.351 | -2.351 |
| 9 | 3.212 | -0.861 |
| 10 | 3.212 | 0.861 |
| 11 | 2.351 | 2.351 |
| 12 | 0.861 | 3.212 |
| 13 | 0 | 1.725 |
| 14 | -1.494 | 0.862 |
| 15 | -1.494 | -0.862 |
| 16 | 0 | -1.725 |
| 17 | 1.494 | -0.862 |
| 18 | 1.494 | 0.862 |

| 16 | | |
|-----|--------|--------|
| PDS | X | Y |
| 1 | -0.923 | 3.142 |
| 2 | -2.475 | 2.145 |
| 3 | -3.242 | 0.466 |
| 4 | -2.979 | -1.360 |
| 5 | -1.771 | -2.755 |
| 6 | 0 | -3.275 |
| 7 | 1.771 | -2.755 |
| 8 | 2.979 | -1.360 |
| 9 | 3.242 | 0.466 |
| 10 | 2.475 | 2.145 |
| 11 | 0.923 | 3.142 |
| 12 | 0 | 1.550 |
| 13 | -1.474 | 0.479 |
| 14 | -0.911 | -1.254 |
| 15 | 0.911 | -1.254 |
| 16 | 1.474 | 0.479 |

- Notes:
1. All dimensions are ± 0.05
 2. All Dimensions are in millimeters.
 3. Layouts shown from the mating face of the female insulator

| Contact PCB Tail Size \varnothing (mm) | Recommended Finished PCB Hole Size \varnothing (mm) |
|---|--|
| 0.5 | 0.75 |
| 0.7 | 0.95 |
| 0.9 | 1.15 |
| 1.3 | 1.55 |



JBX Series Push-Pull Connectors

JBX PCB Layout Patterns - Right Angle Patterns

Size 0 Right Angle PCB Tail Layouts

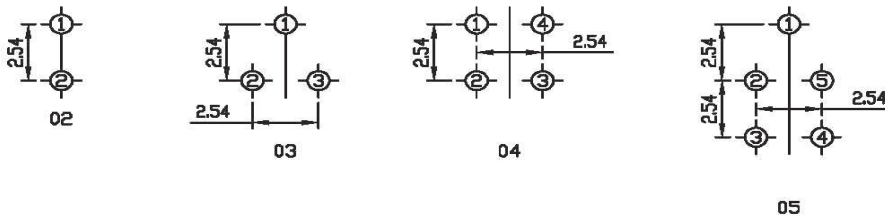

Size 1 Right Angle PCB Tail Layouts

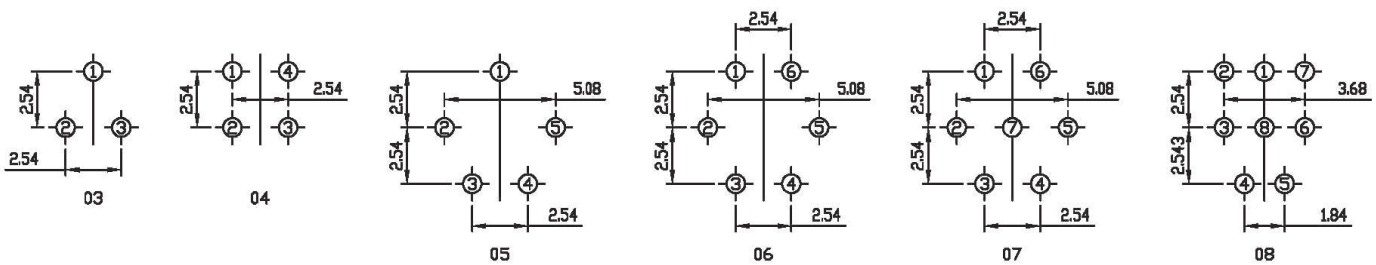

Size 2 Right Angle PCB Tail Layouts

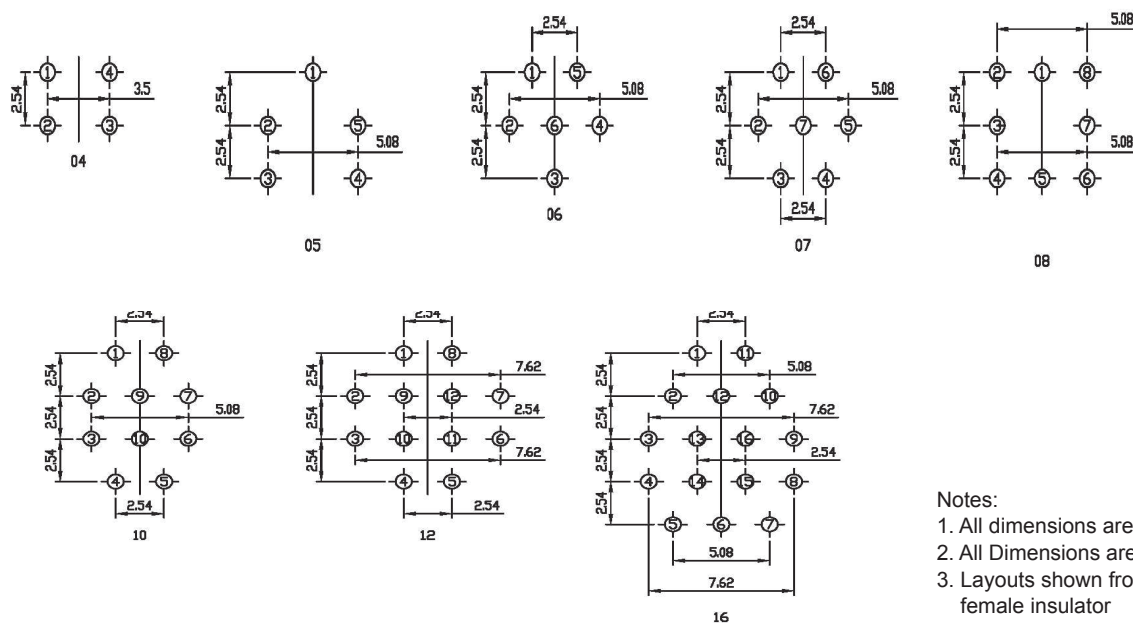

- Notes:
1. All dimensions are ± 0.05
 2. All Dimensions are in millimeters.
 3. Layouts shown from the mating face of the female insulator
 4. Recommended finished PCB hole size $\varnothing 0.83$ min.

JBX Series Push-Pull Connectors



Toolings JBX

Manual extraction tool

Contacts automatically extracted

The extraction tool is similar for both male and female contacts.

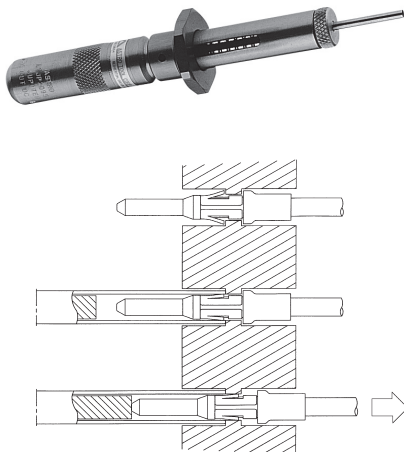

| Shell Size | Contacts | SOURIAU part number | ASTRO part number |
|------------|----------|---------------------|-------------------|
| 0 | 0.7 | JBX OUT DC 07 | ATJP 2045 |
| | 0.9 | JBX OUT DC 09 | ATJP 2057 |
| 1 | 0.7 | JBX OUT DC 07 | ATJP 2045 |
| | 0.9 | JBX OUT DC 09 | ATJP 2057 |
| | 1.3 | JBX OUT DC 13 | ATJP 2077 |
| 2 | 0.7 | JBX OUT DC 07 | ATJP 2045 |
| | 0.9 | JBX OUT DC 09 | ATJP 2057 |
| | 1.3 | JBX OUT DC 13 | ATJP 2077 |
| | 1.6 | JBX OUT DC 16 | ATJP 2095 |
| | 2.0 | JBX OUT DC 20 | ATJP 2115 |
| 3 | 0.7 | JBX OUT DC 07 | ATJP 2045 |
| | 0.9 | JBX OUT DC 09 | ATJP 2057 |
| | 1.3 | JBX OUT DC 13 | ATJP 2077 |
| | 1.6 | JBX OUT DC 16 | ATJP 2095 |
| | 2.0 | JBX OUT DC 20 | ATJP 2115 |

The contact is automatically extracted without the need of pulling onto the cable.

Crimping tool

| Specifications MIL-C-22520 / 7.01 | | | |
|-----------------------------------|-------------------------------------|-----------------------|-------------------------------------|
| | Contacts 0.7 mm - 0.9 mm and 1.3 mm | MIL P/N - SOURIAU P/N | Supplier P/N |
| | | MIL-22520/7-01 | DANIELS: MH860 Buchanan: 616 336 |
| Specifications MIL-C-22520 / 7.01 | | | |
| | Contacts 1.6 mm and 2 mm | MIL P/N SOURIAU P/N | Supplier P/N |
| | | MIL-22520/1-01 | DANIELS: AF8 Buchanan: 615708 |

JBX Series Push-Pull Connectors



Locator for pin and socket 0.7 - 0.9 mm and 1.3 mm contacts



| Shell size | Ø Contact | AWG | Male contact | | | Female contact | | |
|------------|-----------|--------------|-----------------|-------------|-----------|-----------------|-------------|-----------|
| | | | SOURIAU P/N | DANIELS P/N | ASTRO P/N | SOURIAU P/N | DANIELS P/N | ASTRO P/N |
| 0 | 0.7 | 22 - 24 - 26 | JBX 0 OUT LP 07 | 86 - 223 | / | JBX 0 OUT LS 07 | 86 - 224 | / |
| | 0.9 | 20 - 22 - 24 | JBX 0 OUT LP 09 | 86 - 225 | / | JBX 0 OUT LS 09 | 86 - 226 | / |
| 1 | 0.7 | 22 - 24 - 26 | JBX 1 OUT LP 07 | 86 - 196 | 642 - 001 | JBX 1 OUT LS 07 | 86 - 197 | 642 - 004 |
| | 0.9 | 20 - 22 - 24 | JBX 1 OUT LP 09 | 86 - 198 | 642 - 002 | JBX 1 OUT LS 09 | 86 - 199 | 642 - 005 |
| | 1.3 | 18 - 20 - 22 | JBX 1 OUT LP 13 | 86 - 200 | 642 - 003 | JBX 1 OUT LS 13 | 86 - 201 | 642 - 006 |
| 2 | 0.7 | 22 - 24 - 26 | JBX 2 OUT LP 07 | 86 - 202 | 642 - 007 | JBX 2 OUT LS 07 | 86 - 203 | 642 - 010 |
| | 0.9 | 20 - 22 - 24 | JBX 2 OUT LP 09 | 86 - 204 | 642 - 008 | JBX 2 OUT LS 09 | 86 - 205 | 642 - 011 |
| | 1.3 | 18 - 20 - 22 | JBX 2 OUT LP 13 | 86 - 206 | 642 - 009 | JBX 2 OUT LS 13 | 86 - 207 | 642 - 012 |
| 3 | 0.7 | 22 - 24 - 26 | JBX 3 OUT LP 07 | 86 - 217 | 642 - 014 | JBX 3 OUT LS 07 | 86 - 214 | 642 - 017 |
| | 0.9 | 20 - 22 - 24 | JBX 3 OUT LP 09 | 86 - 218 | 642 - 015 | JBX 3 OUT LS 09 | 86 - 215 | 642 - 018 |
| | 1.3 | 18 - 20 - 22 | JBX 3 OUT LP 13 | 86 - 219 | 642 - 016 | JBX 3 OUT LS 13 | 86 - 216 | 642 - 019 |

Turret with locator for pin and socket 1.6 mm and 2 mm contacts

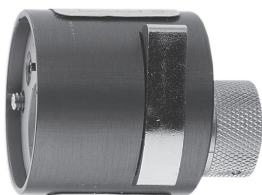

| Shell size | Ø Contact | AWG | Male & female contacts | | |
|------------|-----------|--------------|------------------------|-------------|-----------|
| | | | SOURIAU P/N | DANIELS P/N | ASTRO P/N |
| 2 | 1.6 | 14 - 16 - 18 | JBX 2 OUT LT16 | TH 564 | 650 - 030 |
| | 2 | 12 - 14 - 16 | JBX 2 OUT LT20 | TH 565 | 650 - 031 |
| 3 | 1.6 | 14 - 16 - 18 | JBX 3 OUT LT16 | TH 566 | 650 - 038 |
| | 2 | 12 - 14 - 16 | JBX 3 OUT LT20 | TH 567 | 650 - 035 |

JBX Series Push-Pull Connectors



Conversion table

Milimeters / Inches

| (mm) | (inches) | (mm) | (inches) | (mm) | (inches) |
|------|----------|------|----------|--------|-----------|
| 0.1 | 0.00394 | 8.2 | 0.32308 | 38.0 | 1.49720 |
| 0.2 | 0.00788 | 8.4 | 0.33096 | 38.5 | 1.51690 |
| 0.3 | 0.01182 | 8.6 | 0.33884 | 39.0 | 1.53660 |
| 0.4 | 0.01576 | 8.8 | 0.34672 | 39.5 | 1.55630 |
| 0.5 | 0.01970 | 9.0 | 0.35460 | 40.0 | 1.57600 |
| 0.6 | 0.02364 | 9.2 | 0.36248 | 40.5 | 1.59570 |
| 0.7 | 0.02758 | 9.4 | 0.37036 | 41.0 | 1.61540 |
| 0.8 | 0.03152 | 9.6 | 0.37824 | 41.5 | 1.63510 |
| 0.9 | 0.03546 | 9.8 | 0.38612 | 42.0 | 1.65480 |
| 1.0 | 0.03940 | 10.0 | 0.39400 | 42.5 | 1.67450 |
| 1.1 | 0.04334 | 10.5 | 0.41370 | 43.0 | 1.69420 |
| 1.2 | 0.04728 | 11.0 | 0.43340 | 43.5 | 1.71390 |
| 1.3 | 0.05122 | 11.5 | 0.45310 | 44.0 | 1.73360 |
| 1.4 | 0.05516 | 12.0 | 0.47280 | 44.5 | 1.75330 |
| 1.5 | 0.05910 | 12.5 | 0.49250 | 45.0 | 1.77300 |
| 1.6 | 0.06304 | 13.0 | 0.51220 | 45.5 | 1.79270 |
| 1.7 | 0.06698 | 13.5 | 0.53190 | 46.0 | 1.81240 |
| 1.8 | 0.07092 | 14.0 | 0.55160 | 46.5 | 1.83210 |
| 1.9 | 0.07486 | 14.5 | 0.57130 | 47.0 | 1.85180 |
| 2.0 | 0.07880 | 15.0 | 0.59100 | 47.5 | 1.87150 |
| 2.1 | 0.08274 | 15.5 | 0.61070 | 48.0 | 1.89120 |
| 2.2 | 0.08668 | 16.0 | 0.63040 | 48.5 | 1.91090 |
| 2.3 | 0.09062 | 16.5 | 0.65010 | 49.0 | 1.93060 |
| 2.4 | 0.09456 | 17.0 | 0.66980 | 49.5 | 1.95030 |
| 2.5 | 0.09850 | 17.5 | 0.68950 | 50.0 | 1.97000 |
| 2.6 | 0.10244 | 18.0 | 0.70920 | 51.0 | 2.00940 |
| 2.7 | 0.10638 | 18.5 | 0.72892 | 52.0 | 2.04880 |
| 2.8 | 0.11032 | 19.0 | 0.74860 | 53.0 | 2.08820 |
| 2.9 | 0.11426 | 19.5 | 0.76830 | 54.0 | 2.12760 |
| 3.0 | 0.11820 | 20.0 | 0.78800 | 55.0 | 2.16700 |
| 3.1 | 0.12214 | 20.5 | 0.80770 | 56.0 | 2.20640 |
| 3.2 | 0.12608 | 21.0 | 0.82740 | 57.0 | 2.24580 |
| 3.3 | 0.13002 | 21.5 | 0.84710 | 58.0 | 2.28520 |
| 3.4 | 0.13396 | 22.0 | 0.86680 | 59.0 | 2.32460 |
| 3.5 | 0.13790 | 22.5 | 0.88650 | 60.0 | 2.40340 |
| 3.6 | 0.14184 | 23.0 | 0.90620 | 61.0 | 2.44280 |
| 3.7 | 0.14578 | 23.5 | 0.92590 | 62.0 | 2.48220 |
| 3.8 | 0.14972 | 24.0 | 0.94560 | 63.0 | 2.52160 |
| 3.9 | 0.15366 | 24.5 | 0.96530 | 64.0 | 2.56100 |
| 4.0 | 0.15760 | 25.0 | 0.98500 | 65.0 | 2.60040 |
| 4.1 | 0.16154 | 25.5 | 1.00470 | 66.0 | 2.63980 |
| 4.2 | 0.16548 | 26.0 | 1.02440 | 67.0 | 2.67920 |
| 4.3 | 0.16942 | 26.5 | 1.04410 | 68.0 | 2.71860 |
| 4.4 | 0.17336 | 27.0 | 1.06380 | 69.0 | 2.75800 |
| 4.5 | 0.17730 | 27.5 | 1.08350 | 70.0 | 2.79740 |
| 4.6 | 0.18124 | 28.0 | 1.10320 | 71.0 | 2.83680 |
| 4.7 | 0.18518 | 28.5 | 1.12290 | 72.0 | 2.87620 |
| 4.8 | 0.18912 | 29.0 | 1.14260 | 73.0 | 2.91560 |
| 4.9 | 0.19306 | 29.5 | 1.16230 | 74.0 | 2.95500 |
| 5.0 | 0.19700 | 30.0 | 1.18200 | 75.0 | 3.15200 |
| 5.2 | 0.20488 | 30.5 | 1.20170 | 80.0 | 3.34900 |
| 5.4 | 0.21276 | 31.0 | 1.22140 | 85.0 | 3.54600 |
| 5.6 | 0.22064 | 31.5 | 1.24110 | 90.0 | 3.94000 |
| 5.8 | 0.22852 | 32.0 | 1.26080 | 100.0 | 7.88000 |
| 6.0 | 0.23640 | 32.5 | 1.28050 | 200.0 | 15.76000 |
| 6.2 | 0.24428 | 33.0 | 1.30020 | 400.0 | 23.64000 |
| 6.4 | 0.25216 | 33.5 | 1.31990 | 600.0 | 31.52000 |
| 6.6 | 0.26004 | 34.0 | 1.33960 | 800.0 | 39.40000 |
| 6.8 | 0.26792 | 34.5 | 1.35930 | 1000.0 | 47.28000 |
| 7.0 | 0.27580 | 35.0 | 1.37900 | 1200.0 | 63.04000 |
| 7.2 | 0.28368 | 35.5 | 1.39870 | 1600.0 | 78.80000 |
| 7.4 | 0.29156 | 36.0 | 1.41840 | 2000.0 | 126.08000 |
| 7.6 | 0.29944 | 36.5 | 1.43810 | | |
| 7.8 | 0.30732 | 37.0 | 1.45780 | 3200.0 | |
| 8.0 | 0.31520 | 37.5 | 1.47750 | | |

°C / °F

| (°C) | (°F) |
|------|------|
| - 70 | - 94 |
| - 65 | - 85 |
| - 55 | - 67 |
| - 50 | - 58 |
| - 40 | - 40 |
| 0 | 32 |
| 37 | 98.6 |
| 80 | 176 |
| 125 | 257 |
| 150 | 302 |
| 170 | 338 |
| 200 | 392 |
| 250 | 482 |

Pressure conversion

| bar | psi | mmHg (torr) |
|-----|-------|-------------|
| 10 | 145.0 | 7600 |
| 5 | 72.5 | 3800 |
| 2 | 29.0 | 1520 |
| 1 | 14.5 | 760 |
| 0.5 | 7.2 | 380 |
| 0.1 | 1.4 | 76 |

| mbar | psi | mmHg (torr) |
|------|-------|-------------|
| 100 | 1.4 | 76 |
| 50 | 0.72 | 38 |
| 10 | 0.14 | 7.6 |
| 1.32 | 0.019 | 1 |

JBX Series Push-Pull Connectors



**Request form please fill in and fax to SOURIAU - Customer service
(see the address page for your local contact)**

Name : Tel number : Fax number :
 Title : E-mail :
 Company :
 Address :

Applications :

- Medical Audio Video Instrumentation Nuclear physics
- GPS Transportation Metrology Other

Detailed description of end product, unit or application

Connector description :

- Series : Shell configuration :
- Shell size : Protective boot : Color
- Number of contacts :
- Type of contacts : Solder Crimp Printed circuit 90° printed circuit
- Conductor AWG : Coax type : Other :

Electrical :

- Working voltage (AC/DC) : Current rating :
- Impedance (Ohms) : SWR : Frequency
- Contact resistance : Shielding :
- Fibre optics : Multimode Monomode.....

Environment :

- Temperature : Protection index (IP --) :
- Outside environment :
 - Clear Splash proof..... Sterilization
 - Dirt Fluids Radiation
 - Chemicals Waterproof..... Gases.....
 - Salt waterspray

Projections :

- Prototype quantity : Delivery date :
- Preseries quantity : Delivery date :
- Production quantity : Delivery date :
- Production per year : Number of years :
- Target pricing per connector :

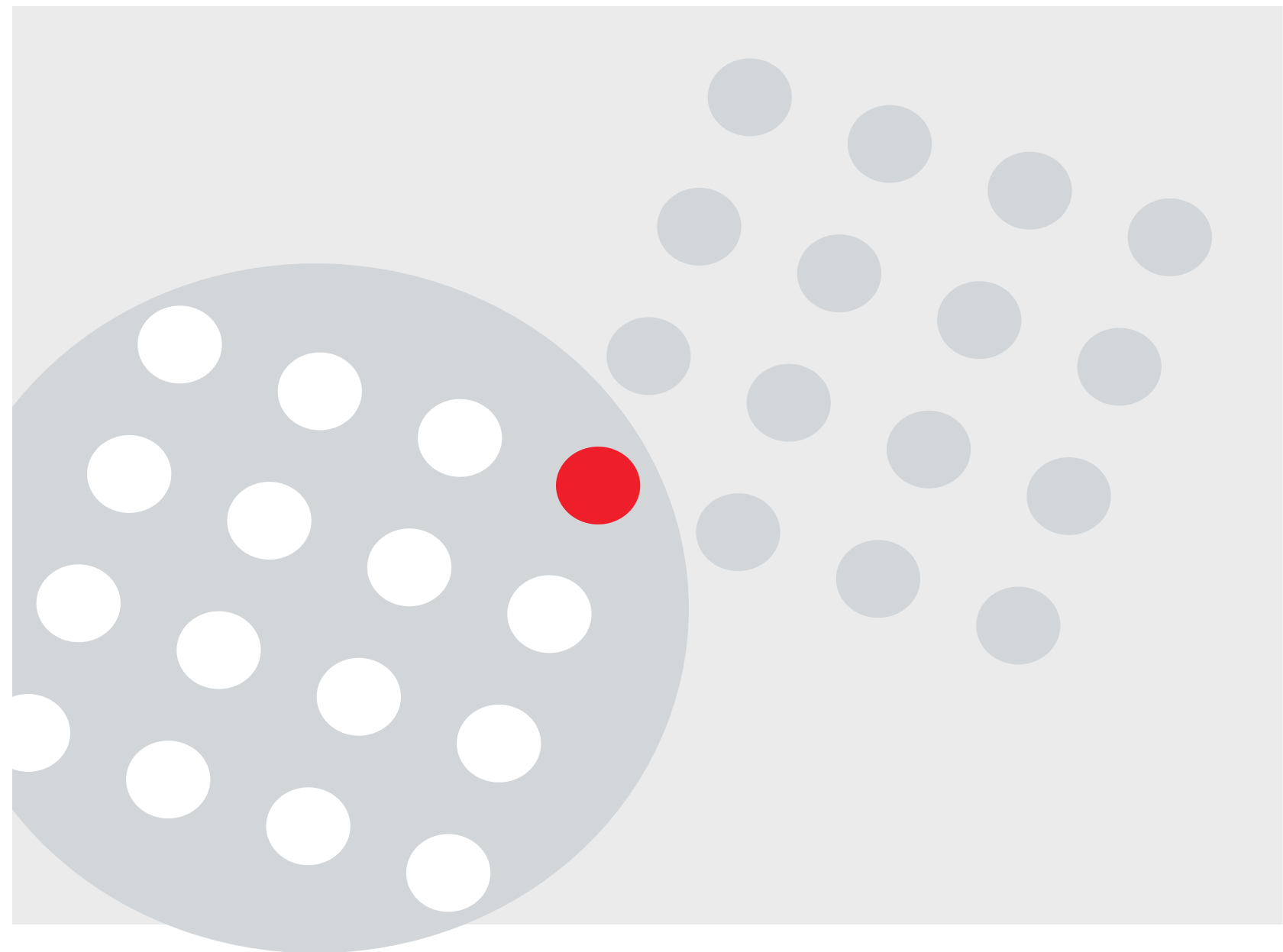

www.souriau.com

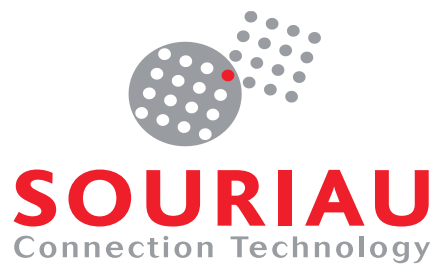

X-ON Electronics

Largest Supplier of Electrical and Electronic Components

Click to view similar products for [Circular Push Pull Connectors](#) category:

Click to view products by [Sunbank](#) manufacturer:

Other Similar products are found below :

[FEA.1B.308.CYCD72Z](#) [6408-201V-13273](#) [D38999/20ZC8JA](#) [D38999/20ZG39BN](#) [D38999/20ZG41PN-LC](#) [D38999/20ZH21SA](#)
[D38999/20ZH53SA](#) [D38999/20ZJ20AA](#) [D38999/20ZJ24AA](#) [D38999/20ZJ24SA](#) [D38999/20ZJ29AA](#) [D38999/20ZJ29PA-LC](#)
[D38999/20ZJ43AA](#) [D38999/20ZJ43BA](#) [D38999/20ZJ43HA](#) [D38999/20ZJ43PA-LC](#) [D38999/20ZJ4AA](#) [D38999/20ZJ61AA](#)
[D38999/20ZJ61PA-LC](#) [D38999/24ZC35BA](#) [D38999/24ZC4AA](#) [D38999/24ZC4SA-LC](#) [D38999/24ZC8SA](#) [D38999/24ZC8SA-LC](#)
[D38999/24ZC98BA](#) [D38999/24ZC98PA-LC](#) [D38999/24ZC98SA](#) [D38999/24ZC98SA-LC](#) [D38999/24ZF11SA-LC](#) [D38999/24ZF32BA](#)
[D38999/24ZF32PA-LC](#) [D38999/24ZF32SA-LC](#) [D38999/24ZF35BA](#) [D38999/24ZF35SA-LC](#) [EXG.00.250.NTNY](#) [FFA.1S.302.CLAZ](#)
[FFA.2S.310.ZLA](#) [FGA.1B.307.CYCD72Z](#) [FGG.0K.305.CYCC40Z](#) [FGG.2K.302.CLAK90Z](#) [FGG.2K.302.CYCC65](#) [FGG.2K.302.CYCC65Z](#)
[FGG.2K.302.CYCC85Z](#) [FGG.2K.303.CYCC65Z](#) [FGG.2K.303.CYCK90](#) [FGG.3B.304.CYCD62Z](#) [FGG.3B.304.CYCD82Z](#)
[FGG.3B.304.CYCD92](#) [FGG.3B.310.CYCD92Z](#) [FGG.3B.330.CYCD62Z](#)