

THIS DRAWING IS A CONTROLLED DOCUMENT FOR SOURIAU USA, INC. IT IS SUBJECT TO CHANGE WITHOUT NOTIFICATION. CONTACT THE DOCUMENT CONTROL CENTER FOR THE LATEST REVISION.

ELECTRICAL:
 EMI SHIELDING : SHIELDED FOR THE RANGE 55dB UP TO 100MHz
 INSULATION RESISTANCE : >500MΩ PER ANSI-EIA-364-D METHOD 21
 MAX. CURRENT RATING : SEE INSULATOR DRAWING
 CONNECTOR TESTING : SEE INSULATOR DRAWING
 CONNECTOR WORKING : SEE INSULATOR DRAWING
ENVIRONMENTAL:
 ENDURANCE: 1000 CYCLES AS PER MIL-STD 1344A, METHOD 2016.1
 SHOCK: 50 g , DURATION 6 ms; AS PER MIL-STD 1344A, METHOD 2004.1
 VIBRATIONS: 10 TO 2000Hz g = 20g, AS PER MIL-STD 1344A, METHOD 2005.1
 PROTECTION INDEX: IP 40 AS PER IEC 529
 ROHS COMPLIANT
 SALT MIST : 48Hr PER SAE AS 1344 METHOD 1001.1 CEI 529
 OPERATING TEMPERATURE: -55°C TO +125°C (-67°F TO +257°F)

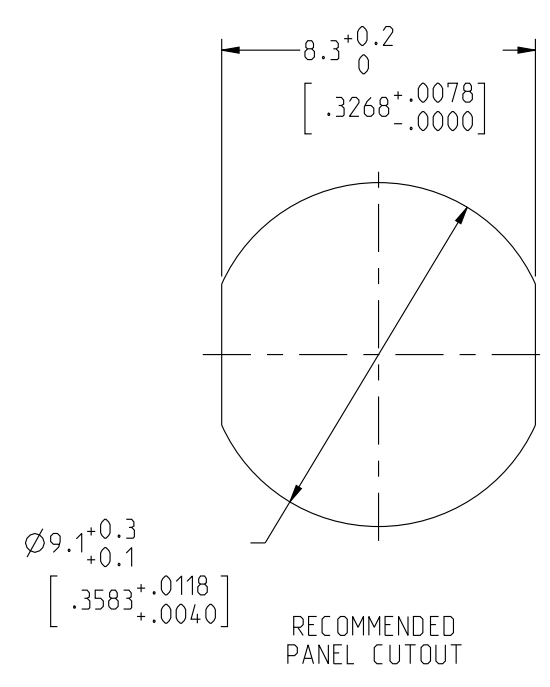

NOTES:
MATERIAL:
 OUTER SHELL & PANEL NUT : BRASS
 SHIELD RING & NUT :
FINISH:
 OUTER SHELL & PANEL NUT : CHROME
 OTHER BRASS PARTS : NICKEL
TOOLS

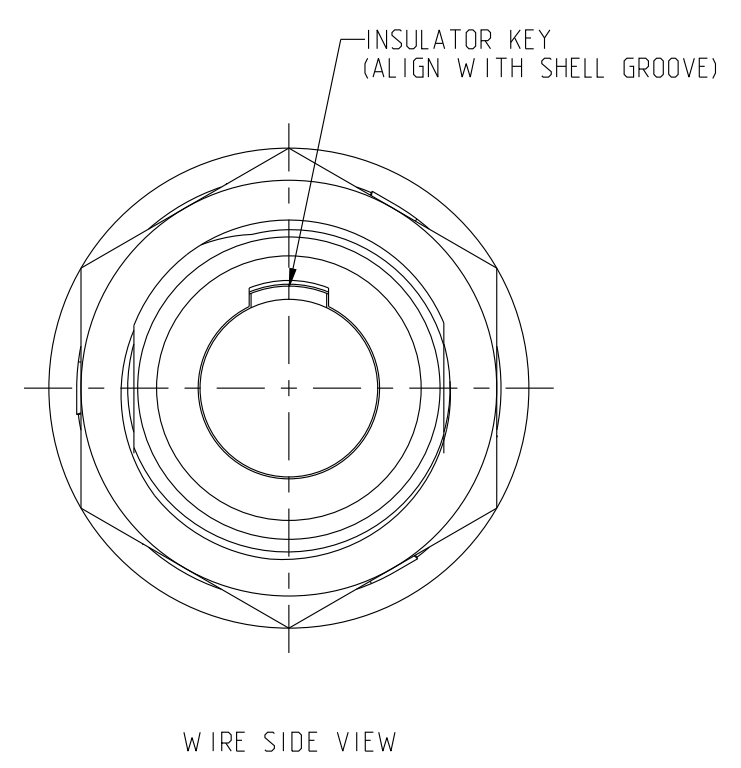
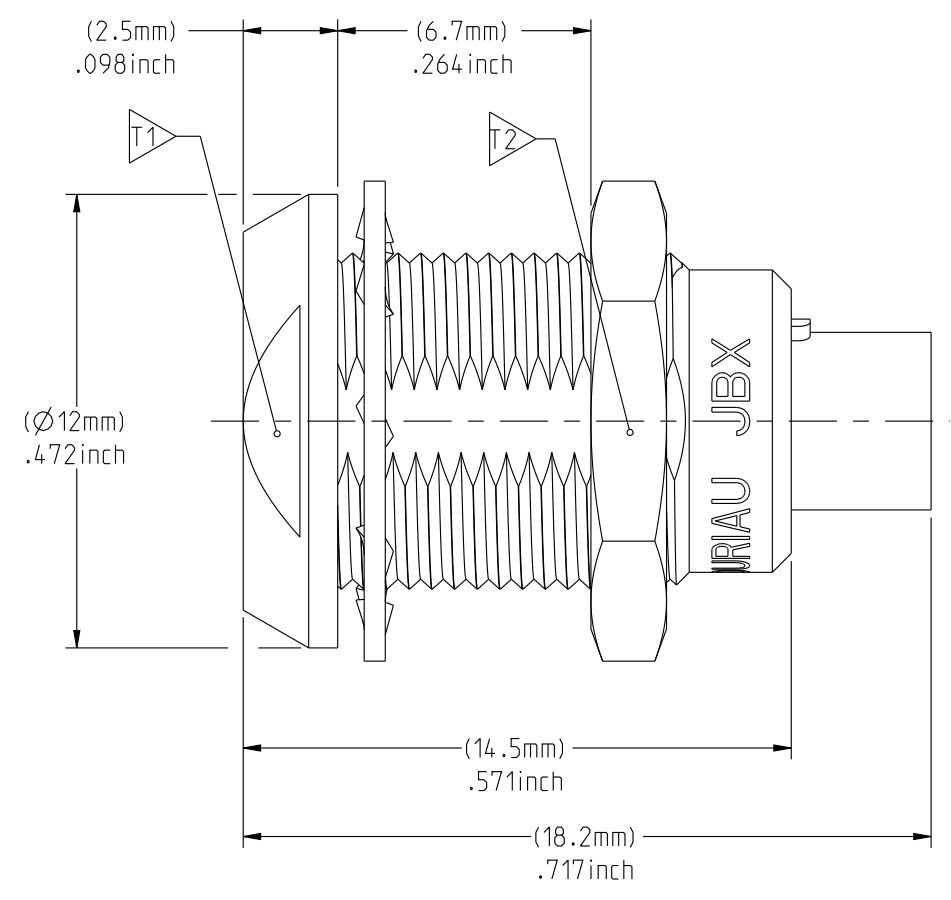
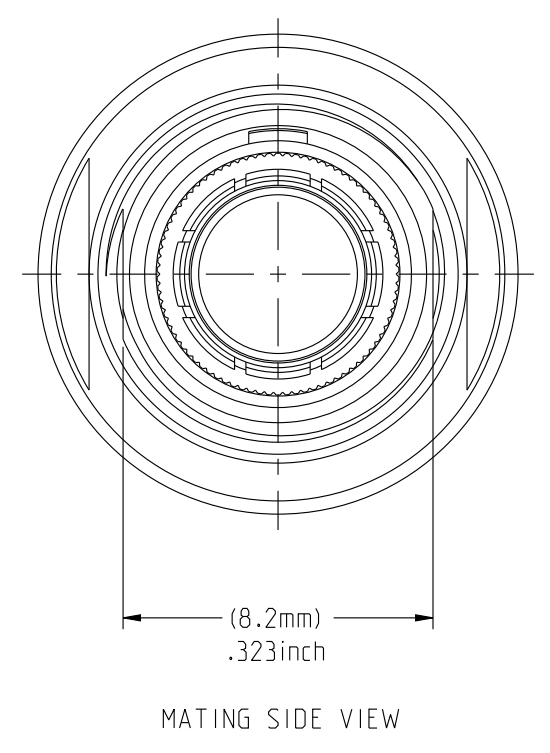

PART LIST	
ITEM NO.	DESCRIPTION
1	SHELL
2	PANEL NUT
3	HEX NUT
4	INSULATOR
5	LOCK WASHER

	TOOLS (JAW DIMENSION)	ADVISED TORQUE IN Nm
T1	10	0.7
T2	11	0.7

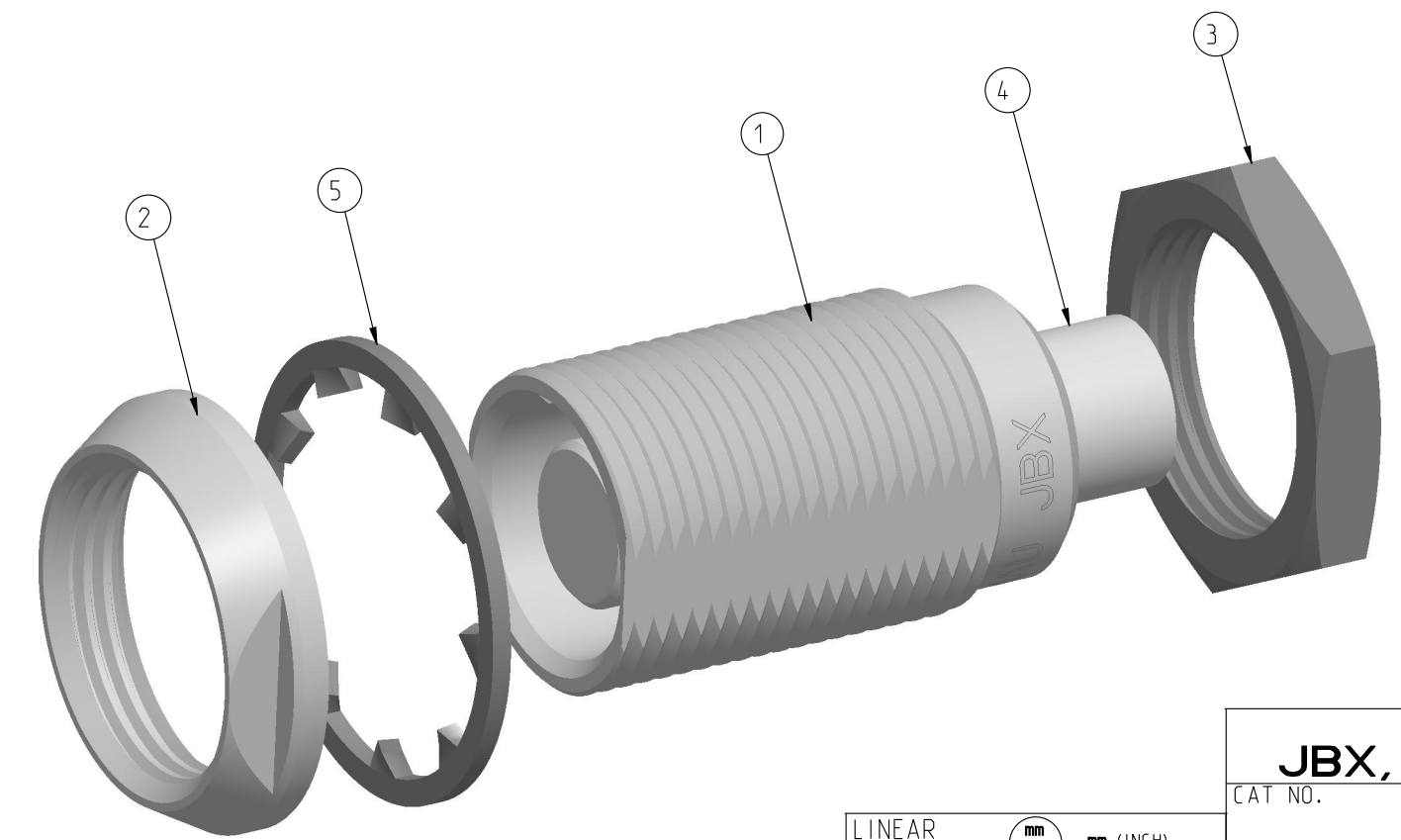

CATALOG NUMBER DESCRIPTION

JBX EA0 XXXXXDX-

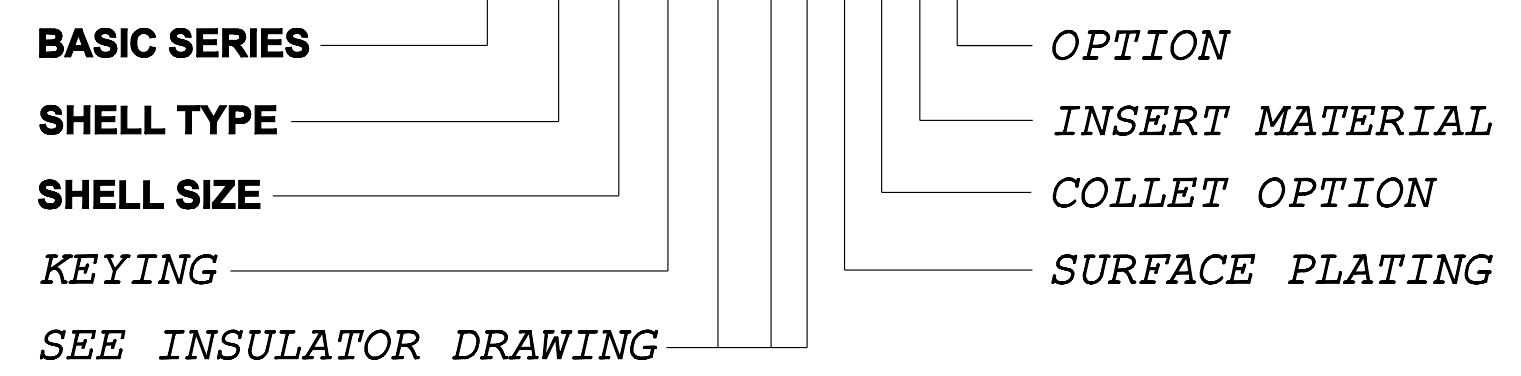

A	RELEASED PER ECN 12258	TJS 06-10-15	EV 06-10-15
REV	DESCRIPTION	BY DATE	CHKD DATE

DRAWING TITLE
JBX, SIZE O, DOUBLE NUT RECEPTACLE
 CAT NO. **JBXEA0**
 CAGE NO: 09922 SIZE: C

CUSTOMER
SOURIAU
 www.souriau.com

APPROVAL
 DRAWN: TJS 01-07-15
 CHKD : EV 01-07-15
 DSGN : EV 01-07-15
 MFG : DH 01-07-15
 QC : BB 01-07-15
 DRAWING SCALE: 5:1
 DRAWING NO. **JBXEAOC** REV **A**
 1 OF 1

INTERPRET THIS DRAWING IN ACCORDANCE WITH ASME Y14.5M - 1994.

LINEAR MEASURE: $\frac{mm}{INCH}$ mm (INCH)	
THIRD ANGLE PROJECTION	
TOLERANCES UNLESS OTHERWISE SPECIFIED	
No. OF PLACES	mm [INCH]
WHOLE No.	±0.5 [±.02]
ONE PLACE	±0.2 [±.008]
TWO PLACES	±0.1 [±.004]
ANGLES ±1°	

THIS DRAWING IS A CONTROLLED DOCUMENT FOR SOURIAU USA, INC. IT IS SUBJECT TO CHANGE WITHOUT NOTICE. CONTACT THE DOCUMENT CONTROL CENTER FOR THE LATEST REVISION.

THE INFORMATION CONTAINED IN THIS DRAWING IS CONFIDENTIAL AND MAY NOT BE DISCLOSED WITHOUT WRITTEN CONSENT FROM SOURIAU USA, INC.

2

1

DWG. NO. JBXOINSFCC	FEMALE INSULATOR, CRIMP CONTACT				<p>CONTACT TYPE : F (FEMALE)</p> <p>CONTACT TERMINATION : C (CRIMP)</p> <p>MATERIAL :</p> <p>CONTACT: CUPRO-NICKEL</p> <p>CLIP: COPPER ALLOY</p> <p>INSULATOR: PEEK</p> <p>FINISH: GOLD</p> <p>CONTACTS : GOLD</p>	B
CONTACT LAYOUT	02	03	04	05		
FRONT SIDE VIEW						A
REAR SIDE VIEW						
CONTACT						
ISO VIEW						
CONTACT	ØC	0.9	0.9	0.7	0.7	
	ØF	1.1	1.1	0.85	0.85	
	MAX. AWG	20	20	22	22	
	MAX. CURRENT RATING (A)	10	10	7	7	
	CONTACT RESISTANCE (mΩ)	3.5	3.5	5	5	
INSULATOR	NUMBER OF CAVITY	2	3	4	5	
	MAX. CURRENT RATING	10	8	7	6.5	
	TEST VOLTAGE (Vrms)	1400	1300	1350	800	
	WORKING VOLTAGE (Vdc/Vrms)	660/460	600/420	660/460	400/260	

CATALOG NUMBER DESCRIPTION

JBXXX 0 X YY F C XXXX

BASIC SERIES		OPTION	
SHELL TYPE		INSERT MATERIAL	
SHELL SIZE		COLLET OPTION	
KEYING		SURFACE PLATING	
CONTACT LAYOUT		CONTACT TERMINATION	
		CONTACT TYPE	

REV	DESCRIPTION	BY	DATE	CHKD	DATE
B	REVISED PER ECN 12286	RSK	06-10-15	EV	06-10-15
A	RELEASED PER ECN 12264	TJS	03-10-15	EV	03-10-15

DRAWING TITLE

JBX, SIZE 0, FEMALE INSULATOR, CRIMP CONTACT

CAT. NO. **JBXOINSFC**

CAGE NO: 09922	SIZE: B
----------------	---------

CUSTOMER	SOURIAU
WWW.SOURIAU.COM	1 OF 1

2

1

PRO-E

X-ON Electronics

Largest Supplier of Electrical and Electronic Components

Click to view similar products for [Circular Push Pull Connectors](#) category:

Click to view products by [Sunbank](#) manufacturer:

Other Similar products are found below :

[FEA.1B.308.CYCD72Z](#) [D38999/20ZC8JA](#) [D38999/20ZG39BN](#) [D38999/20ZG41PN-LC](#) [D38999/20ZH21SA](#) [D38999/20ZH53SA](#)
[D38999/20ZJ24SA](#) [D38999/20ZJ29PA-LC](#) [D38999/20ZJ43HA](#) [D38999/20ZJ43PA-LC](#) [D38999/20ZJ61PA-LC](#) [D38999/24ZF11SA-LC](#)
[D38999/24ZF32BA](#) [D38999/24ZF32PA-LC](#) [D38999/24ZF32SA-LC](#) [D38999/24ZF35BA](#) [D38999/24ZF35SA-LC](#) [EXG.00.250.NTNY](#)
[FFA.00.250.CTAZ](#) [FFA.1S.302.CLAZ](#) [FFA.1Y.410.CTAC52](#) [FFA.2S.310.ZLA](#) [FFG.1B.302.CLAD52Z](#) [FFG.1B.304.CLAD42Z](#)
[FFG.1B.304.CLAD72Z](#) [FFG.1B.308.CLAD42Z](#) [FGA.1B.304.CLAD62Z](#) [FGA.1B.304.CYCD72Z](#) [FGA.1B.305.CLAD76](#)
[FGA.1B.306.CYCD72](#) [FGA.1B.307.CYCD72Z](#) [FGA.1B.308.CLAD76Z](#) [FGA.1B.308.CYCD42Z](#) [FGA.1B.308.CYCD52Z](#)
[FGA.1B.308.CYCD72Z](#) [FGA.1B.310.CLAD42](#) [FGA.1B.310.CLAD52Z](#) [FGA.1B.316.CLAD42](#) [FGA.1B.316.CLAD62Z](#)
[FGA.1B.316.CLAD76](#) [FGB.0B.307.CYCD31Z](#) [FGB.1B.302.CLAD72](#) [FGB.1B.303.CYCD62](#) [FGB.1B.305.CLAZ](#) [FGB.1B.307.CYCD62Z](#)
[FGB.1B.316.CLAD42](#) [FGC.0B.309.CLAD56](#) [FGC.1B.304.CLAD52Z](#) [FGC.1B.305.CLAD52Z](#) [FGC.1B.308.CLAD42](#)