

Silencer

With external thread

Material: Sinter bronze/copper or brass

Operating temperature range: -10°C to +70°C

Mounting Position: optional

Operating Pressure: 0-12 bar

Connection

R	A	B	C	D	SW	Noise level at 6 bar against atmospheric pressure***	Normal nominal flow l/min****	Part No.
G 1/8 a	20.5	4	4	9	12	77 dB	1750	L055.4054
G 1/4 a	28.5	5	4.7	11.2	15	77 dB	2700	L055.4056
G 3/8 a	42.6	7.5	8.8	12.1	19	77 dB	4500	L055.4058
G 1/2 a	52.7	10	9	15.6	24	78 dB	6000	L055.4060
G 3/4 a	54	9	9.5	21.7	30	80 dB	6800	L055.4062

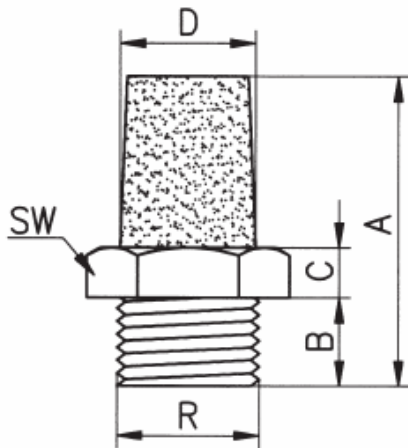

*** measured at a distance of 1m

****at 6 bar at the entrance against atmospheric pressure

Shock resistant plastic blow gun

Operating Pressure: 1-10 bar

Operating temperature range: -10°C to +50°C

Connection	Short Nozzle	Nozzle Diameter	C	PN	Part No.
G 1/4 i	Yes	1.5 mm	-	10 bar	L139.0010
With plug nipple for DN7.2 coupling	Yes	1.5 mm	24	10 bar	L139.0016

Adjustable blow gun

Material: Aluminium

Operating Pressure: 1-10 bar

Step-less changes in the amount of air expelled (up to full capacity) can be achieved by changing the actuating travel via the operating handle.

Connection	Short Nozzle	Nozzle Diameter	C	PN	Part No.
G 1/4 i	Yes	1.5 mm	-	10 bar	L139.0020
With plug nipple for DN7.2 coupling	Yes	1.5 mm	24	10 bar	L139.0027

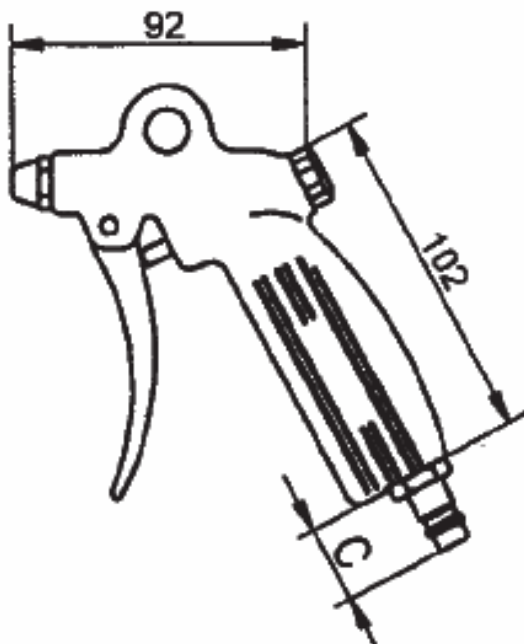

Angled Extention Nozzle

Length	Nozzle Diameter	Connection	C	Part No.
100 mm	2 mm	M12 x 1.25	87	L140.0003
150 mm	2 mm	M12 x 1.25	110	L140.0004
250 mm	2 mm	M12 x 1.25	235	L140.0005

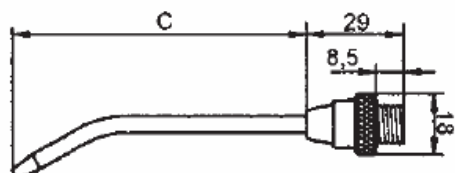

Tube cutter Type MRS-1

Suitable for cutting PE, PP, PU and PVC tubes upto 14mm in diameter.

Part Number: L146.2450



Tube crimp tool Type MRS-2-B

The tube cutter is suitable for cutting plastic tubes and polyamide tubes up to 28mm in diameter.

Included in delivery: Crimp tool and case.

Part Number: L146.2461



Replacement blades for MRS-2-B crimp tool

Part Number: L146.2466

X-ON Electronics

Largest Supplier of Electrical and Electronic Components

Click to view similar products for [mader](#) manufacturer:

Other Similar products are found below :

[L146.2461](#) [L140.0004](#) [L046.1089](#) [L053.1380](#) [230091](#)