

# LC2H

	<b>DIN HALF SIZE LCD COUNTER</b>	<h1 style="margin: 0;">LC2H</h1>
---	--------------------------------------	----------------------------------



Panel mounting type  
One-touch installation type



Panel mounting type  
Installation frame type



PC board mounting type

## Features

**1. 8.7 mm .343 inch Character Height (previously 7 mm)**  
Easy-to-read character height increased from 7 mm to 8.7 mm .276 inch to .343 inch.



**2. Plenty of Digits**



**3. Counting Speed Switchable between 2 kHz and 30 Hz**

**4. Panel Mounting Type Features 2 Installation Methods**

Comes with very easy one-touch installation type and also installation frame type that uses the bracket on the timer/counter. Choose a method that suits the application.

**5. Battery Replacement Easy on Environment**

To replace battery simply remove body for the one-touch installation type, and remove battery lid for the installation frame type.

**6. Screw Terminals Designed for Safety** Built in finger protection.

**7. Panel Covers Replacable (Standard color is ash gray.)** Change the panel design by replacing with a black panel cover.

**8. Conforms to IP66 Protective Construction (Only installation frame type.) (Front panel surface)**

**9. Input Methods**

- 1) Non-voltage input method
- 2) Voltage input method
- 3) Free voltage input method

**10. Backlight Type Added to Series and Now 2-color Switchable (green/red)**

Easy viewing even in dark places and switchable between green and red (Voltage input type).

**11. Conforms to Safety Regulations**

## Product chart

Type		Standard type			Backlight type
		Non-voltage input type	Voltage input type (4.5 to 30 V DC)	Free voltage input type (24 to 240 V AC/DC)	Voltage input type (4.5 to 30 V DC)
Installation type	One-touch installation type	○	○	○	○
	Installation frame type	○	○	○	○
PC board mounting type		○	—	—	—

## Product types

### 1. Panel mounting type

#### 1) One-touch installation type

##### ① Standard type

No. digits	Counting speed	Front reset	Input method	Part No.
8 digits	2 kHz/30 Hz switchable	Yes	Non-voltage input type	LC2H-FE-2KK
			Voltage input type (4.5 to 30 V DC)	LC2H-FE-DL-2KK
	30 Hz		Free voltage input type (24 to 240 V AC/DC)	LC2H-FE-FV-30

Note) Please ask us about types without front resetting.

##### ② Backlight type

No. digits	Counting speed	Front reset	Input method	Part No.
8 digits	2 kHz/30 Hz switchable	Yes	Voltage input type (4.5 to 30 V DC)	LC2H-FE-DL-2KK-B

## 2) Installation frame type

## ① Standard type

No. digits	Counting speed	Front reset	Input method	Part No.
8 digits	2 kHz/30 Hz switchable	Yes	Non-voltage input type	LC2H-F-2KK
			Voltage input type (4.5 to 30 V DC)	LC2H-F-DL-2KK
	30 Hz		Free voltage input type (24 to 240 V AC/DC)	LC2H-F-FV-30

Note) Please ask us about types without front resetting.

## ② Backlight type

No. digits	Counting speed	Front reset	Input method	Part No.
8 digits	2 kHz/30 Hz switchable	Yes	Voltage input type (4.5 to 30 V DC)	LC2H-F-DL-2KK-B

## 2. PC board mounting type

No. digits	Counting speed	Front reset	Input method	Part No.
8 digits	2 kHz	No	Non-voltage input type	LC2H-C-2K-N
	30 Hz			LC2H-C-30-N

## Specifications

## 1. Panel mounting type

Item	Type	Standard type		Backlight type	Standard type
		Non-voltage input	Voltage input		Free voltage type
No. digits		8 digits			
External power supply		Not required (built-in battery)			
Max. counting speed		2 kHz/30 Hz (Switchable by switch)			30 Hz (Note 2)
Count input	Min. input signal width (ON: OFF = 1:1)	0.25 ms/16.7 ms (Switchable by switch)			16.7 ms
	Input method (signal)	Non-voltage input using contacts or open collector connection	High level: 4.5 to 30 V DC Low level: 0 to 2 V DC		High level: 24 to 240 V AC/DC Low level: 0 to 2.4 V AC/DC
	Input impedance	When shorted: Max. 10 k When open: Max. 750 k	Approx. 4.7 k		—
	Residual voltage	Max. 0.5 V	—		—
Reset input	Min. input signal width	200 ms			
	Input method (signal)	Non-voltage input using contacts or open collector connection	High level: 4.5 to 30 V DC Low level: 0 to 2 V DC		Non-voltage input using contacts or open collector connection
	Input impedance	When shorted: Max. 10 k When open: Max. 750 k	Approx. 4.7 k		When shorted: Max. 10 k When open: Max. 750 k
	Residual voltage	Max. 0.5 V	—		Max. 0.5 V
Display method		7-segment LCD		7-segment LCD With green/red backlight	7-segment LCD
Breakdown voltage (initial)		Between charged and uncharged parts: 1,000 V AC for 1 minute.			Between charged and uncharged parts: 2,000 V AC for 1 minute.
Insulation resistance (initial)		Min. 100 M (measured at 500 V DC) Measurement location same as for break down voltage.			
Backlight power		—		24 V DC (±10%)	—
Protective construction (Note 3)		IEC Standard IP66 (only panel front: when using rubber gasket)			
Accessories (Note 3)		Rubber gasket, mounting bracket			
Battery life		7 years (at 25°C 77°F) Note 1			6 years (at 25°C 77°F)

Notes) 1. The value given for battery life is calculated based on continuous operation (count input signal ON/OFF = 1:1), therefore, this value is not guaranteed.

Also, battery life is decreased 30% when operation is continuous with 2 kHz count inputting in 2 kHz mode.

2. Operation is at 25 Hz when using 24 V AC.

3. Only for installation frame type.

# LC2H

## 2. PC board mounting type

Item		Type	PC board mounting type	
Input method			Non DC voltage input	
No. digits			8 digits	
Rated operation voltage			3 V DC	
Allowable operation voltage range			2.7 to 3.3 V DC	
Current consumption			Max. 30 $\mu$ A (max. 250 $\mu$ A during reset input)	
Max. counting speed			2 kHz	30 Hz
Count input	Min. input signal width (ON: OFF = 1:1)		0.25 ms	16.7 ms
	Input method		Non-voltage input using contacts or open collector connection	
	Input impedance		When shorted: Max. 10 k When open: Max. 750 k	
	Residual voltage		Max. 0.5 V	
Reset input	Min. input signal width		10 ms	
	Input method		Non-voltage input using contacts or open collector connection	
	Input impedance		When shorted: Max. 10 k When open: Max. 750 k	
	Residual power		Max. 0.5 V	
Break down voltage (initial)			Between charged and uncharged parts: 1,000 V AC for 1 minute.	
Insulation resistance (initial)			Min. 100 M (measured at 500 V DC) Measurement location same as for break down voltage.	

## 3. Common

Item		Type	Panel mounting/PC board mounting types	
Vibrationresistance	Functional		10 to 55 Hz (1 cycle/min.), single amplitude: 0.15 mm .006 inch (10 min. on 3 axes)	
	Destructive		10 to 55 Hz (1 cycle/min.), single amplitude: 0.375 mm .015 inch (1 hr. on 3 axes)	
Shock resistance	Functional		Min. 98 m/s <sup>2</sup> (4 times on 3 axes)	
	Destructive		Min. 294 m/s <sup>2</sup> (5 times on 3 axes)	
Operation temperature			-10 to +55°C +14 to +131°F (without frost or dew)	
Storage temperature			-25 to +65°C -13 to +149°F (without frost or dew)	
Ambient humidity			35 to 85% RH	

## Part names

### 1. Front reset button

This button resets the count value. It does not work when the lock switch is ON. Be aware that battery life will decrease if this switch is used frequently.

### 2. Lock switch (Refer to chart on right.)

Disable the front reset button.

Note) Turn ON at the LCD side (reset disabled) and OFF at the terminal block side (reset enabled).

### 3. Count speed switch (Refer to chart on right.)

Use this switch to switch the count speed between 30 Hz and 2 kHz. (On the non-voltage and voltage input types, 30 Hz is on the LCD side and 2 kHz is on the terminal block side. Fixed at 30 Hz for free voltage input type.)

Note) You must press the front reset button when you change the count speed switch setting.

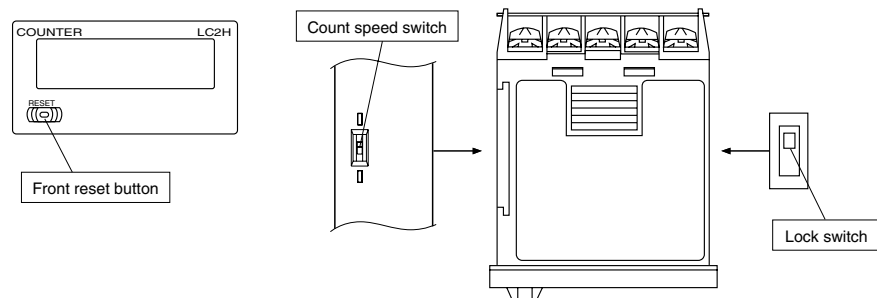

	Non-voltage input/voltage input	Free voltage input
Lock switch (Unit display 1)	(Terminal block side) (LCD side)	— (Fixed at 30 Hz)
Count speed switch (Unit display 2)	(Terminal block side) (LCD side)	— (Fixed at 30 Hz)

Notes) 1. \*Default setting when shipped.  
2. Make the switch setting before installing to panel.

# LC2H

mm inch

General tolerance:  $\pm 1.0 \pm .039$

## Dimensions

### 1. Panel mounting type

#### • External dimensions

##### 1) One-touch installation type

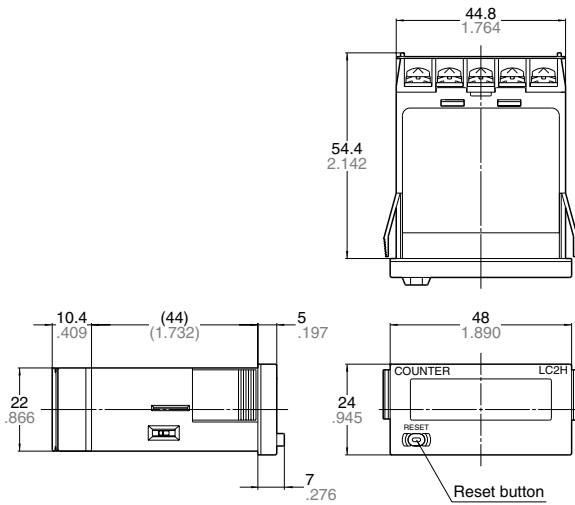

#### • Panel installation diagram

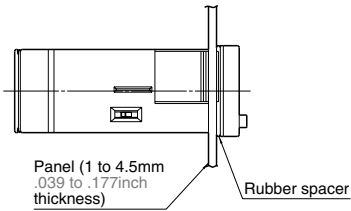

Note) When installing to a 4.5 mm .177 inch thick panel, remove the rubber spacer first.

##### 2) Installation frame type

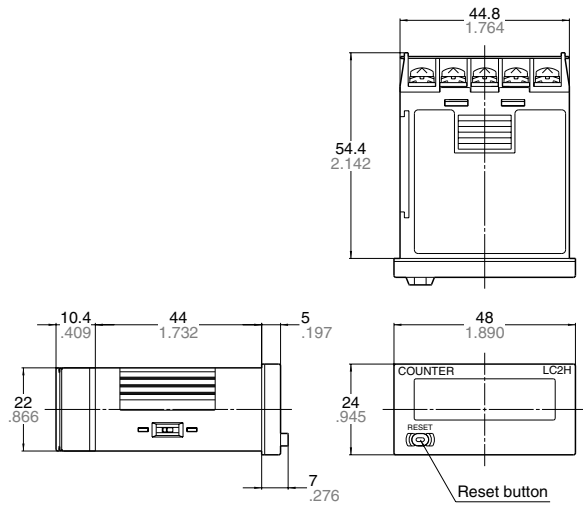

#### • Panel installation diagram

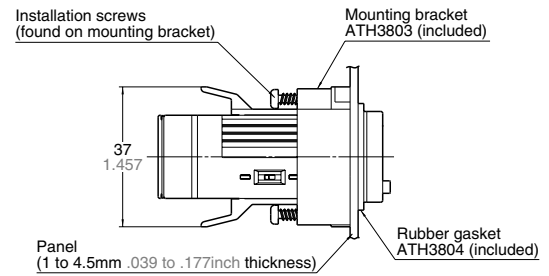

#### • Panel cut-out dimensions

The standard panel cut-out is shown below. Use the mounting bracket (ATH3803) and the rubber packing (ATH3804). (Only mounting bracket installation type.)

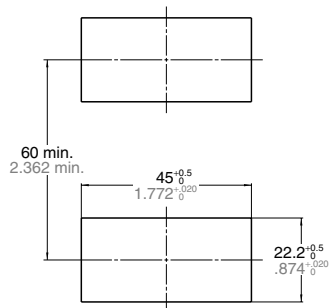

#### • When installing repeatedly (sealed installation) (Only mounting bracket installation type.)

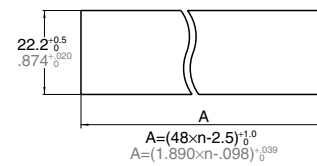

Notes 1. Suitable installation panel thickness is 1 to 4.5 mm .039 to .177 inch.  
2. Waterproofing will be lost when installing repeatedly (sealed installation).

## • Terminal layout and wiring diagrams

### 1) Standard type

Non voltage input type	Voltage input type	Free voltage input type

# LC2H

## 2) Backlight type

### Voltage input type

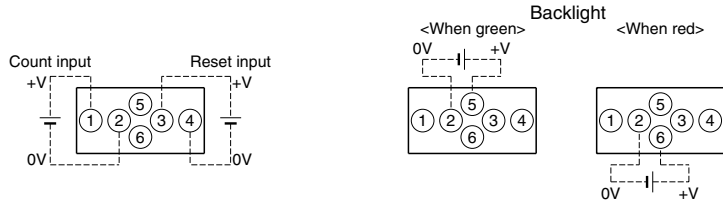

## 2. PC board mounting type

General tolerance:  $\pm 1.0 \pm .039$  mm inch

### External dimensions

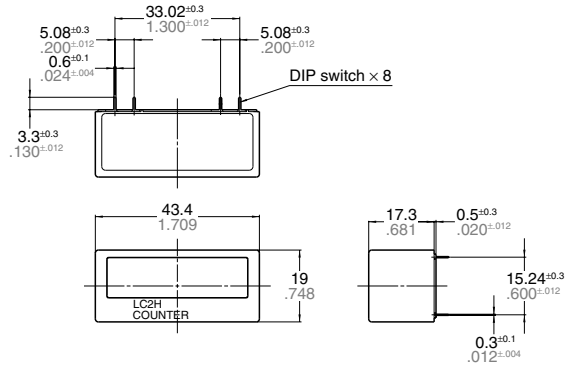

### PC board pattern (BOTTOM VIEW)

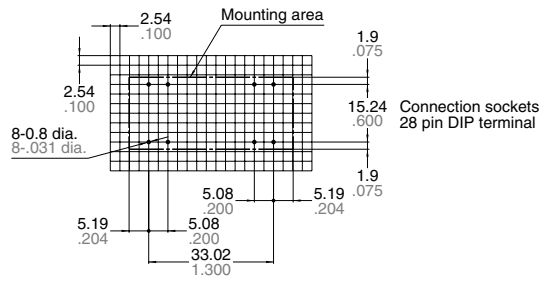

### Terminal layout and wiring diagrams

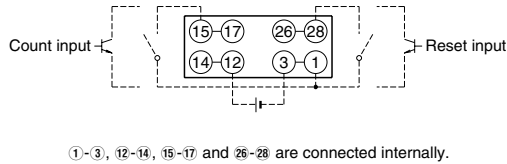

## Input method

### 1. Standard type

Non-voltage input type			
Panel mounting type		PC board mounting type	
Contact input	Transistor input NPN transistor	Contact input	Transistor input NPN transistor

Notes) 1. When using contact input, since current flow is small from terminals ① and ③ on the panel mounting type and terminals ⑮ to ⑰ and ⑳ to ㉔ on the PC board mounting type, please use relays and switches with high contact reliability.  
2. When using transistor input, use the following as a guide for which transistors (Tr) to use for inputting. (Collector withstand voltage  $\geq 50$  V, leakage current  $< 1 \mu$  A)

Contact input	Voltage input type		Free voltage input type
	NPN transistor	PNP transistor	

Notes) 1. ② and ④. (The input and reset circuits are functionally insulated.)  
2. When using transistor (Tr) input, use the right as a guide. (Collector withstand voltage  $\geq 50$  V, leakage current  $< 1 \mu$  A)  
3. Be aware that the application of voltage that exceeds the voltage range of the H level to the count input terminal, and the application of voltage to the reset input terminal, can cause damage to the internal elements.

2. Backlight type

Contact input	Voltage input type		Backlight connection
	Transistor input		
	NPN transistor	PNP transistor	

- Notes) 1. Do not reverse the polarities when connecting the DC voltage for the backlight.  
 2. ② and ④. (The input and reset circuits are functionally insulated.)  
 3. When using transistor (Tr) input, use the right as a guide. (Collector withstand voltage  $\geq 50$  V, leakage current  $< 1 \mu\text{A}$ )  
 4. Be aware that the application of voltage that exceeds the voltage range of the H level to the count input terminal, and the application of voltage to the reset input terminal, can cause damage to the internal elements.

Explanation of operation

- Counting takes place when the count input signal is ON.
- Counting resumes again when the count value reaches 99999999 (full scale value) and then returns to "0" with a new count input.
- No measurement takes place when a reset is input.
  - When reset is ON, resetting takes place and the count becomes "0".
  - Press the front reset button when you want to reset manually (only panel installation type).

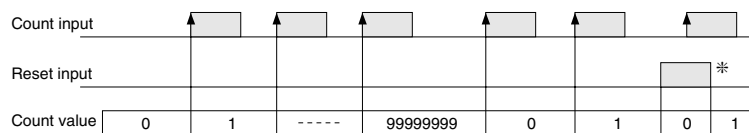

Note) \*Count becomes "1" when the reset input is turned OFF while the count signal is being input.

Note) Be aware that battery life will decrease if the count input or reset input are left ON.

Cautions for use

1. Non-voltage input type  
 For both panel mounting and PC board mounting types

- Never apply voltage to the non-voltage input type. This will damage the internal elements. Also, since there is a possibility of erroneous operation, do not connect in parallel the inputs of a non-voltage input type and another counter from a single input signal.
- Since the current flow is very small from the count input and reset input terminals (① and ③ on the panel mounting type and terminals ⑮ to ⑰ and ⑳ to ㉓ on the PC board mounting type) please use relays and switches with high contact reliability.
- When inputting with an open collector of a transistor, use a transistor for small signals in which ICBO is  $1 \mu\text{A}$  or less and always input with no voltage.
- When wiring, try to keep all the input lines to the count and reset inputs as short as possible and avoid running them together with high voltage and power transmission lines or in a power conduit. Also, malfunctions might occur if the floating capacitance of these wires exceeds  $500 \text{ pF}$  (10 m 32.808 ft. for parallel wires of 2

mm<sup>2</sup>). When using 2 kHz mode, use with a wiring floating capacitance of  $120 \text{ pF}$  (3 m 9.843 ft. for parallel wires of 2 mm<sup>2</sup>). In particular, when using shielded wiring, be careful of the capacitance between wires.  
**PC board mounting type**

- For external power supply use manganese dioxide or lithium batteries (CR type: 3V).
- Always reset after external power is applied and confirm that the display reads "0".
- Make the wiring from the battery to the counter unit as short as absolutely possible. Also, be careful of polarity.
- Calculate battery life with the following formula.

$$t = A/I$$

t: battery life [h]  
 I: LC2H current consumption [mA]  
 A: battery capacity until minimum operation voltage is reached [mAh]

- Hand solder to the lead terminal. Do not dipsolder. With the tip of the soldering iron at  $300^\circ\text{C}$   $572^\circ\text{F}$  perform soldering within 3 seconds (for 30 to 60 W soldering iron).

2. Voltage input type

- Be aware that applying more than 30 V

DC to count input terminals ① and ②, and reset input terminals ③ and ④ will cause damage to the internal elements.

- For external resetting use H level (application of 4.5 to 30 V DC) between reset terminals ③ and ④ of the rear terminals. In this case, connect + to terminal ③ and - to terminal ④. This is the valid polarity; therefore, the counter will not work if reversed.

- When wiring, try to keep all the input lines to the count and reset inputs as short as possible and avoid running them together with high voltage and power transmission lines or in a power conduit. Also, malfunctions might occur if the floating capacitance of these wires exceeds  $500 \text{ pF}$  (10 m 32.808 ft. for parallel wires of 2 mm<sup>2</sup>).

3. Free voltage input type

- Use count input terminals ① and ② for free voltage input and reset terminals ③ and ④ for non-voltage input.
- Be aware that the application of voltage that exceeds the voltage range of the H level to the count input terminal, and the application of voltage to the reset input terminal, can cause damage to the internal elements.

# LC2H

3) Since the current flow is very small from reset input terminal ③, please use relays and switches with high contact reliability.  
 4) When inputting a reset with an open collector of a transistor, use a transistor for small signals in which ICBO is 1  $\mu$ A or less and always input with no voltage.  
 5) To reset externally, short reset input terminals ③ and ④ on the rear.  
 6) Input uses a high impedance circuit; therefore, erroneous operation may occur if the influence of induction voltage is present. If you plan to use wiring for the input signal that is 10 m or longer (wire capacitance 120 pF/m at normal temperature), we recommend the use of a CR filter or the connection of a bleeder resistor.

## 4. How to reset multiple panel mounting type counters all at once (input is the same for count)

### Non-voltage input type

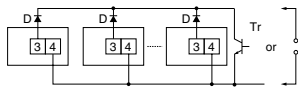

Notes) 1. Use the following as a guide for choosing transistors used for input (Tr).  
 Leakage current < 1  $\mu$ A  
 2. Use as small a diode (D) as possible in the forward voltage so that the voltage between terminals 3 and 4 during reset input meets the standard value (0.5 V).  
 ( At IF = 20  $\mu$ A, forward voltage 0.1 and higher.)

### Voltage input type

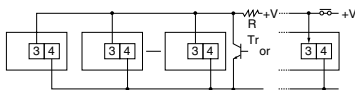

Note) Make sure that H (reset ON) level is at least 4.5 V.

## 5. Backlight luminance

To prevent varying luminance among backlights when using multiple Backlight types, please use the same backlight power supply.

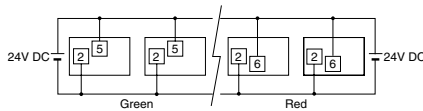

## 6. Insulation sheet

Before using a panel mounting type, please pull and remove the insulation sheet from the side of the product in the direction of the arrow.  
 In consideration that the product might be stored for long periods without being used, an insulation sheet is inserted before shipping. Remove the insulation sheet and press the front reset button.

## One-touch installation type

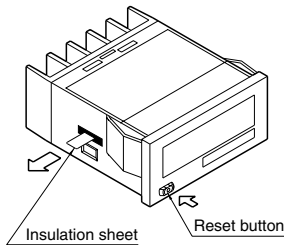

## Installation frame type

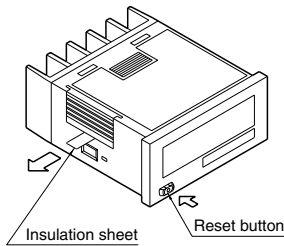

## 7. Waterproof construction (Installation frame type)

The operation part of the panel installation type (Installation frame type) is constructed to prevent water from entering the unit and a rubber gasket is provided to prevent water from entering the gap between the unit and the panel cutout. There must be sufficient pressure applied to the rubber gasket to prevent water from entering. Be sure to use the installation reinforcement screws when installing the frame (ATH3803).

Note) The one-touch installation type is not waterproof.

## 8. Do not use in the following environments

- 1) In places where the temperature changes drastically.
- 2) In places where humidity is high and there is the possibility of dew. (When dew forms the display may vanish and other display errors may occur.)

## 9. Conditions of use

- 1) Do not use in places where there is flammable or corrosive gas, lots of dust, presence of oil, or where the unit might be subject to strong vibrations or shocks.
- 2) Since the cover is made of polycarbonate resin, do not use in places where the unit might come into contact with or be exposed to environments that contain or-

ganic solvents such as methyl alcohol, benzene and thinner, or strong alkali substances such as ammonia and caustic soda.

## 10. Cautions regarding battery replacement

- 1) Remove wiring before replacing the battery. You may be electrocuted if you come into contact to a part where high voltage is applied.
- 2) Make sure you are not carrying a static electric charge when replacing the battery.
- 3) Battery replacement procedure
  - ① One-touch installation type
    1. Using a tool remove the up/down hook of the case.
    2. Pull the unit away from the case.
    3. Remove the battery from the side of the unit. Do not touch the display or other parts.
    4. Before inserting wipe clean the surface of the battery.
    5. Insert the battery with the + and - sides in the proper position.
    6. After replacing the battery return the unit to the case. Verify that the hook of the case has properly engaged.
    7. Before using press the reset button on the front.

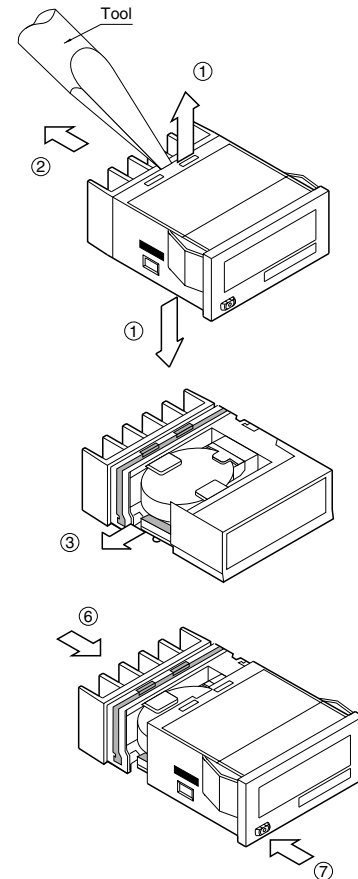

② Installation frame type

1. Remove the battery cover ① from the case.
2. Remove the battery ② from the side of the case. The battery will come loose if you put the battery side face down and lightly shake the unit
3. Before inserting wipe clean the surface of the battery.
4. Insert the battery with the + and – sides in the proper position.
5. After replacing the battery return the battery cover to the case ⑤. Verify that the hook of the battery cover is properly engaged.
6. Before using press the reset button ⑥ on the front.

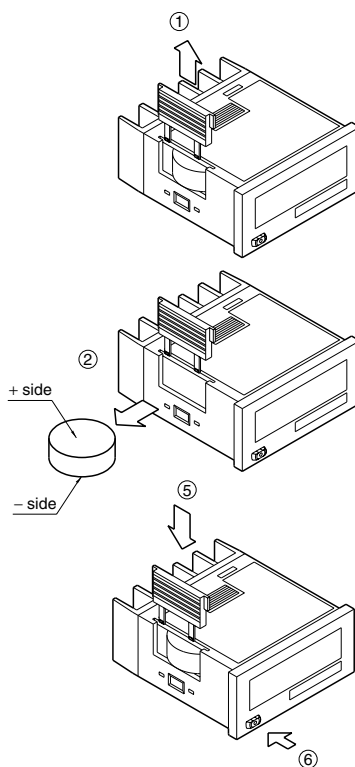

Options

1. Accessories

Panel cover (black)



Part No.: AEL3801

You can change the design of the front panel by replacing it with this black panel cover. The counter comes with an ash gray panel cover as standard.

2. Lithium battery (3 V)



Part No.: ATH3802

Comes packaged with the LC2H (excluding the PC board mounting type).

**Warning**

- Make sure the + and – polarities are positioned correctly.
- Do not throw the old battery into a fire, short circuit it, take it apart, or allow it to come into contact with heat.
- The battery is not rechargeable.

3. Installation parts

Mounting bracket (suitable for installation frame type)

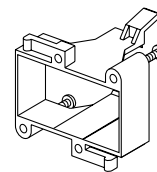

Part No.: ATH3803

Packaged with LC2H (panel mounting type installation frame type).

Rubber gasket (suitable for installation frame type)



Part No.: ATH3804

Packaged with LC2H (panel mounting type installation frame type).



## X-ON Electronics

Largest Supplier of Electrical and Electronic Components

*Click to view similar products for [panasonic](#) manufacturer:*

Other Similar products are found below :

[ECE-A1HKAR47](#) [ELK-EA102FA](#) [ELC-09D151F](#) [EEC-S0HD224H](#) [ELL-5PS3R3N](#) [HC2-H-DC48V-F](#) [HL2-HP-AC120V-F](#) [HL2-H-DC12V-F](#) [HL2-HP-DC12V-F](#) [HL2-HP-DC6V-F](#) [HL2-HP-DC24V-F](#) [HC4-H-DC24V](#) [HL2-HTM-DC24V-F](#) [HL2-HTM-AC24V-F](#) [HC4-H-AC24V](#) [HC4-H-AC120V](#) [EEC-RG0V155H](#) [AZH2031](#) [RP-SDMF64DA1](#) [EEF-UD0K101R](#) [EVM-F6SA00B55](#) [RP-SMLE08DA1](#) [ELC-12D101E](#) [ERA-3YEB272V](#) [EEC-RF0V684](#) [ERA-3YEB153V](#) [ELC-3FN2R2N](#) [ERA-3YEB512V](#) [ERJ-1GEJ564C](#) [ERZ-V20R391](#) [ETQ-P3W3R3WFN](#) [ELL-ATV681M](#) [ELK-EA100FA](#) [EEF-UD0J101R](#) [LC-R121R3P](#) [ERA-3YEB303V](#) [ERZ-V05V680CB](#) [EEF-UE0K101R](#) [ELK-E101FA](#) [EEC-S0HD224V](#) [EVQ-PAC05R](#) [ELK-EA222FA](#) [LT4H-DC24V](#) [LT4HL8-AC24V](#) [LT4HW-AC24V](#) [LT4HWT8-AC240V](#) [LT4HWT-AC240VS](#) [CX-444-P-Z](#) [CY-122A-P](#) [ETQ-P5M470YFM](#)