

**Smallest World-Wide 2400 BPS Modem**

**Description**

Xecom's XE2420G offers unprecedented design flexibility. It provides a global common communications solution in the smallest available package. The XE2420G fits a standard 68-Pin PLCC socket and can be socketed or soldered onto the board in an automated assembly process. The XE2420G allows incorporation of a dial-up access where no other modem will fit.

The surface mount package and small size of the XE2420G are particularly impressive because it is a complete modem. The DAA, RAM, Crystal; everything is included. Like all Xecom modems, the XE2420G includes transferrable FCC Part 68 Registration.

No 2400 BPS modem incorporates more features than the XE2420G. The XE2420G is one of the few low-speed modems available with built-in error correction. The XE2420G incorporates both a sleep mode and power down mode making it ideal for battery powered applications. The XE2420G also incorporates Handset Interrupt to prevent conflicts in shared line applications.

**Features**

- \* Small Size: The HyPLCC™ measures less than 1 inch by 1 inch square and 0.350 inches thick
- \* Surface-mountable: The HyPLCC™ package is equivalent to a 68-Pin PLCC device.
- \* Data transfer from 300 to 2400 BPS using V.22bis, V.22, V.23, V.21, Bell 212A, and Bell 103 Protocols
- \* Modem Control and Configuration via industry standard AT Commands.
- \* Supports V.42 and MNP error correction;
- \* Complete integrated solid-state DAA includes, Ring Detect, Loop Current Holding Circuit, Hook Switch and Metallic Surge Protection;
- \* User Transferrable FCC Part 68 Registration
- \* Complies with telephone networks around the world.
- \* UL60950 Recognition
- \* Handset Interrupt detects parallel telephone pick-up
- \* Low Power operation, typically less than 100 mW, includes automatic sleep mode and power down operation;

**XE2420G BLOCK DIAGRAM**

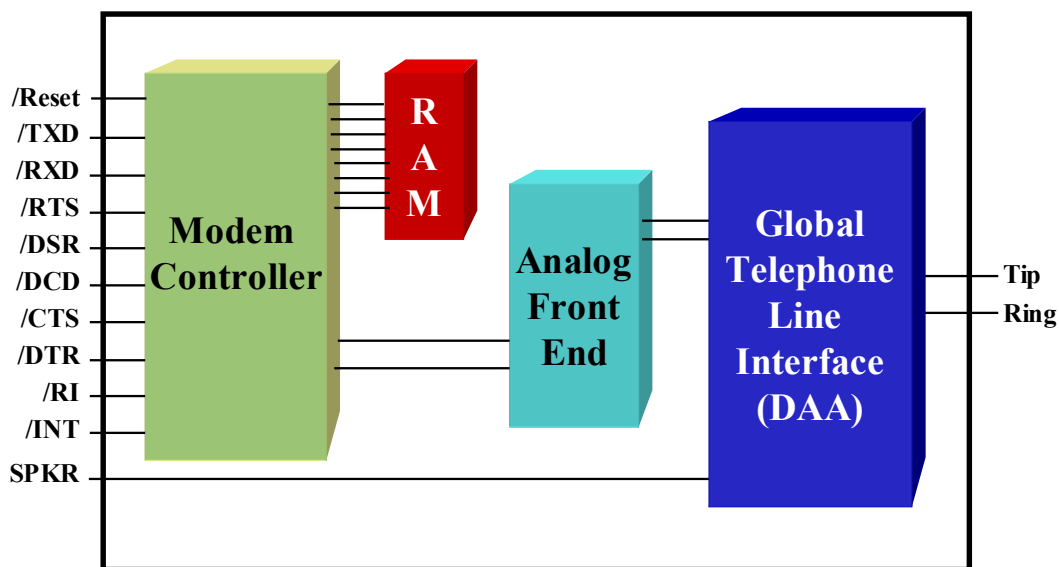

**XE2420G Mechanical Specifications**

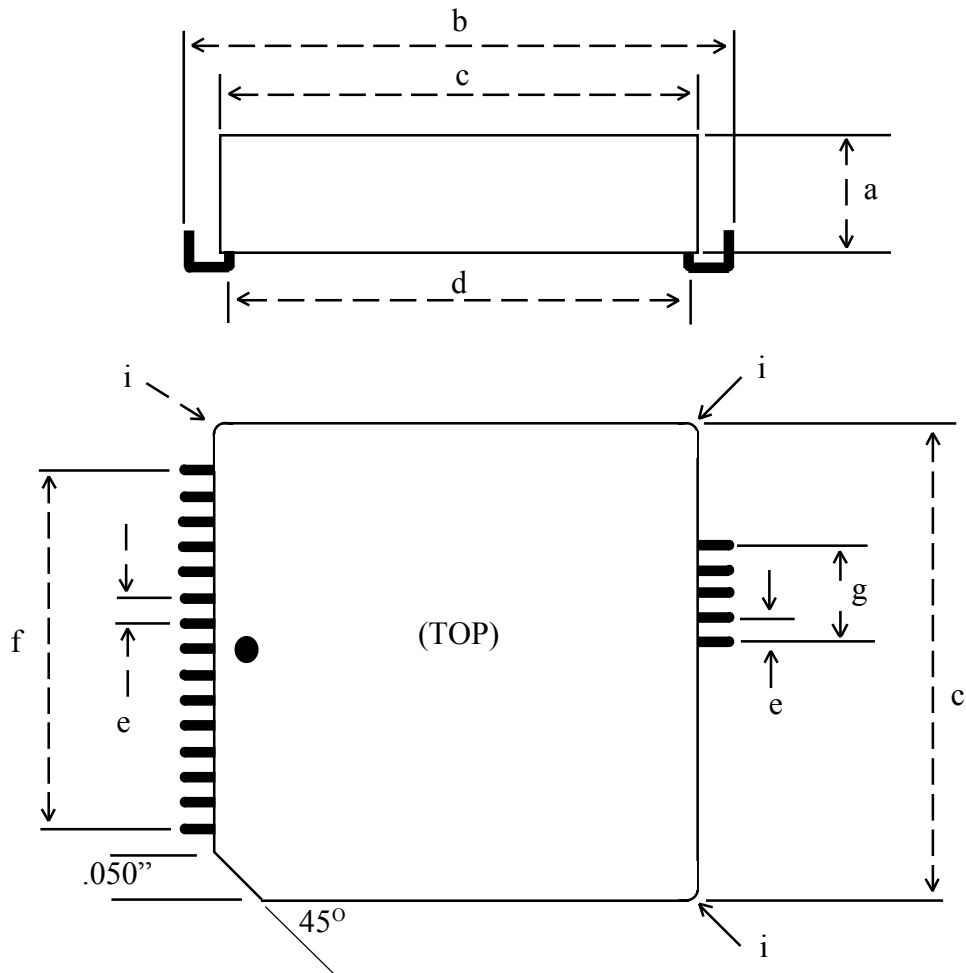

Dimension	Inches			Millimeters		
	Min	Typ	Max	Min	Typ	Max
a	0.345	0.350	0.355	8.76	8.89	9.02
b	0.985	0.990	0.995	25.02	25.15	25.27
c	0.950	0.955	0.960	24.13	24.26	24.38
d	0.910	0.920	0.930	23.11	23.37	23.62
e	0.045	0.050	0.055	1.15	1.27	1.40
f	0.695	0.700	0.705	17.65	17.78	17.91
g	0.195	0.200	0.205	10.03	10.16	10.29
i(radius)	0.015	0.020	0.025	0.13	0.25	0.38

## XE2420G Pin Configuration

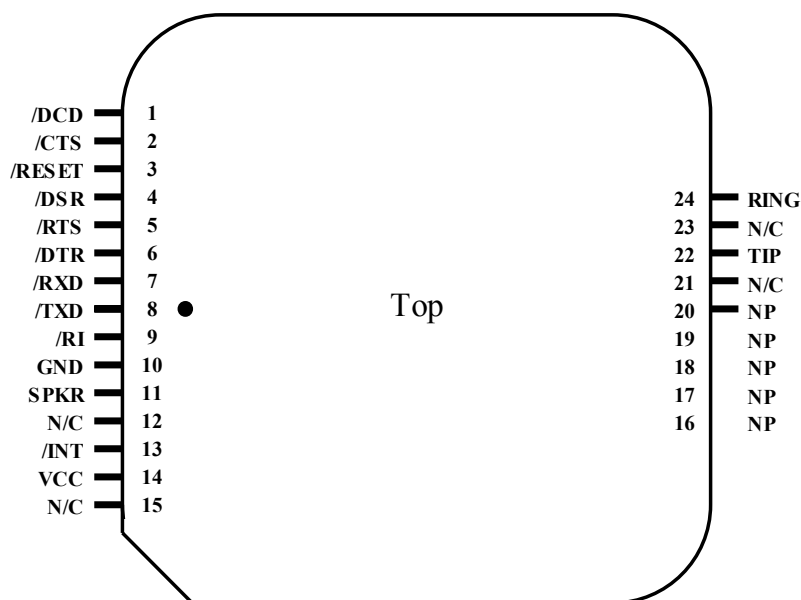

### Pin Descriptions

PIN	NAME	DESCRIPTION
1	/DCD	/DCD is an active low output from the modem. /DCD indicates the presence of a valid carrier signal.
2	/CTS	/CTS is an active low output from the modem. When hardware flow control is active, the modem asserts /CTS to indicate that it can accept data from the terminal equipment on /TXD.
3	/RESET	/RESET is an active low input which initiates a modem hardware reset. /RESET must be active for a minimum of 100 milliseconds for a proper modem reset sequence. No external reset is required; if none is used the /RESET signal should be left open.
4	/DSR	/DSR is active low output from the modem. /DSR is forced active.
5	/RTS	/RTS is an active low input to the modem. When hardware flow control is active, /RTS indicates to the modem that the host has data to send.
6	/DTR	/DTR is an active low input to the modem. The operation of /DTR is controlled by bit 15 of register U70 and is normally disabled. When enabled /DTR indicates the Host is ready to communicate. If /DTR is removed while the modem is on-line it will exit data mode and enter command mode.
7	/RXD	/RXD provides the path for received data and modem responses to be sent from the modem to the host terminal equipment.
8	/TXD	/TXD provides the path for transmitted data and modem commands to be passed from the host terminal equipment to the modem.

## XE2420G Pin Descriptions (continued)

PIN	NAME	DESCRIPTION
9	/RI	The /RI signal reports on the presence of an incoming ring signal. When a ring occurs across Tip and Ring, the /RI output goes low and toggles with the cadence of the ring signal.
10	Ground	Ground provides the reference voltage for all host interface signals.
11	SPKR	SPKR allows connection of a speaker to monitor modem operations. SPKR cannot directly drive a speaker. An amplifier with a minimum input impedance of 300 ohms is required. The signal on SPKR is controlled by the ATM command.
12	N/C	No internal connection
13	/INT	/INT provides an active low hardware interrupt signal from the XE2420G. The operation of this interrupt pin is programmable using the modem's register U70.
14	VCC	VCC provides 3.3 volt power to the modem.
15	N/C	No internal connection
16-19	NP	No Pin
20-21	N/C	No internal connection
22	Tip	<p>The Ring and Tip signals provide modem the connection to the telephone line. FCC Part 68 Rules require a 1500 volt isolation barrier between the telephone line and all other circuits. This isolation must be preserved throughout the system.</p> <p>The telephone company places a DC "Battery" voltage across Tip and Ring on all public switched telephone lines. The XE2420G will operate regardless of the polarity of this "Battery" voltage. The "Battery" voltage drives up to 100 milliamps of DC loop current.</p> <p>UL60950 requires minimum creepage and clearances distances be maintained between the Tip and Ring traces and all other circuits. Clearance is the shortest distance between conductive circuits; creepage is the distance between conductive surfaces along the surface</p>
23	N/C	No internal connection, To prevent damage in case of voltage surges on the telephone line, we recommend that nothing be connected to this pin.
24	Ring	<p>The Ring and Tip signals provide modem the connection to the telephone line. FCC Part 68 Rules require a 1500 volt isolation barrier between the telephone line and all other circuits. This isolation must be preserved throughout the system.</p> <p>The telephone company places a DC "Battery" voltage across Tip and Ring on all public switched telephone lines. The XE2420G will operate regardless of the polarity of this "Battery" voltage. The "Battery" voltage drives up to 100 milliamps of DC loop current.</p> <p>UL60950 requires minimum creepage and clearances distances be maintained between the Tip and Ring traces and all other circuits. Clearance is the shortest distance between conductive</p>

## XE2420G Soldering Instructions

The XE2420G is subject to damage if over-exposed to heat during solder reflow operations. Following the soldering instructions below will ensure that the process of soldering the module to the board does not damage the modem. The XE2420G must not be exposed to direct Infrared (IR) heating. If your process includes direct IR heating, you must shield the XE2420G from the infrared rays.

Maximum Temperature	220° C
Maximum Time at 220° C	20 Seconds
Maximum Time above Eutectic (180° C)	90 Seconds
Maximum Preheat Dwell Time	180 Seconds

**Maximum Recommended Solder Temperature Profile**

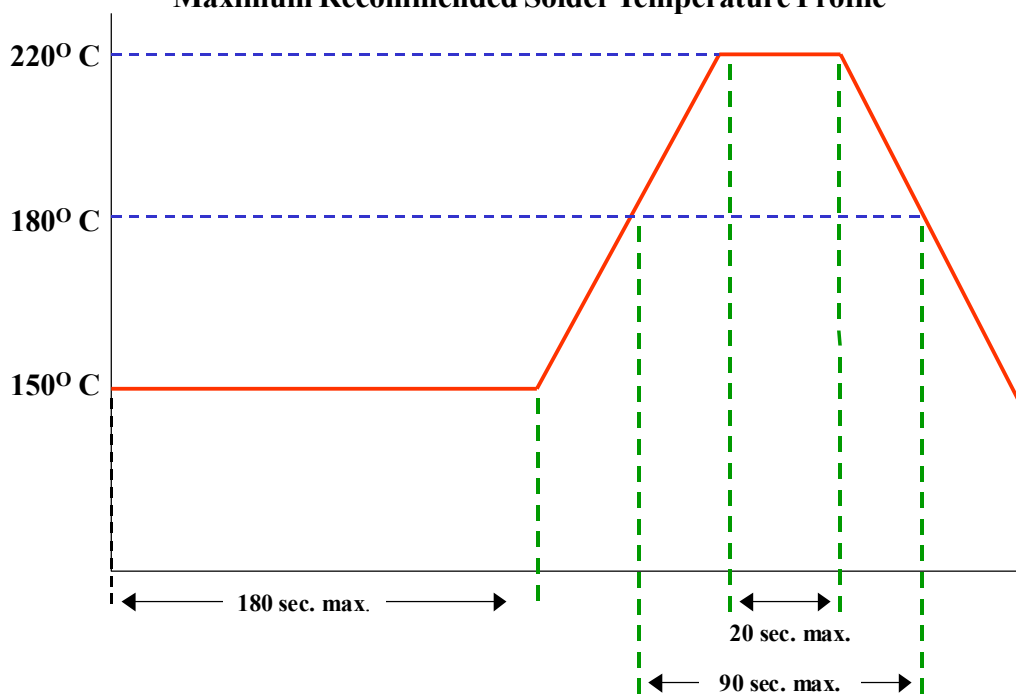

## XE2420G Electrical Specifications

Parameter	Min	Typ	Max	Units	Comments
VCC	3.0	3.3	3.6	Volts	
ICC		30	40	mA	On Line
ICC (Sleep Mode)		10		mA	
ICC (Power down Mode)			50	uA	U65=2000h
Ring Voltage Detected	26		150	VRMS	Type B Ringer
Ring Frequency Detected	15.3		68	Hz	Type B Ringer
Telephone Loop Current	10	40	100	ma	
Line Impedance		600		Ohms	
Data Transmit level		-12.0	-9.0	dBm	
DTMF Transmit Level		-2.5	0	dBm	Avg over 3 second interval
Voh	2.4			Volts	
Vol			0.4	Volts	
Vih	2.0		VCC+0.3	Volts	
Vil	-0.3		0.8	Volts	

### XE2420G ABSOLUTE MAXIMUM RATINGS

Storage Temperature	-25° C to +85° C
Operating Temperature Range <sup>1</sup>	0° C to +70° C
Maximum Time Above Eutectic (183° C)	90 seconds
Preheat Dwell Time	120 to 180 seconds
<sup>1</sup> The XE2420G can be ordered with an Operating Temperature of -40° C to +85° C at extra cost. Order XE2420G-ITR or to specify Industrial Temperature Range (ITR).	

## XE2420G Typical Connection Diagram

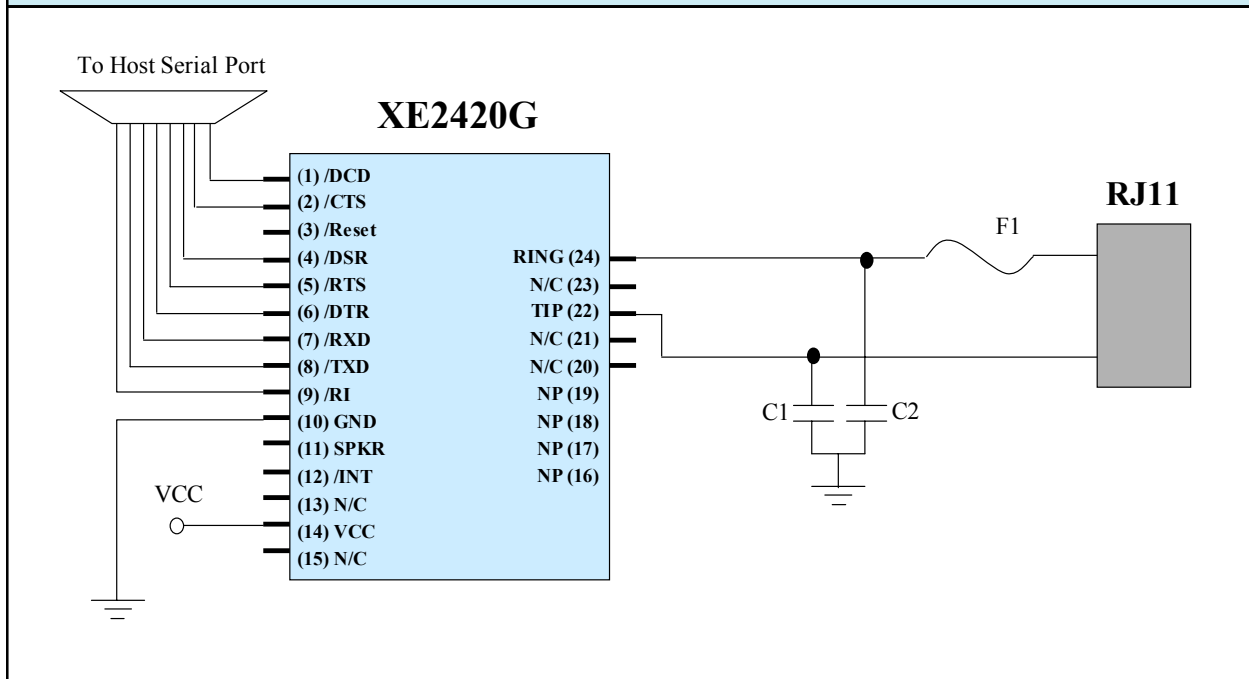

### Parts List for XE2420G Typical Connection Diagram

Reference Designation	Qty	Description
C1, C2	2	Cap. 470 pfd 2600V, Panasonic ECKDRS471
F1	1	PTC, Raychem TR600-150

#### Notes:

- 1 C1 and C2 are high-voltage capacitors which may be required for EMI filtering in your system. Without these components you may experience unintended radiation when the telephone cable is attached to your system. We recommend selecting components such as the Panasonic ECKDRS471. This 470 pfd, 3000 volt capacitor will direct the high frequency harmonics to the system ground. These capacitors must be rated at a minimum of 1500 volts to maintain the isolation required by FCC Part 68 Rules.
2. If additional components, such as ferrite beads, are connected in series with Tip and Ring to provide additional EMA filtering, Xecom recommends adding surge protection in front of those components to protect them from damage due to lightning strikes. Xecom recommends the Teccor Sidactor to provide this type of supplemental protection.
3. The XE2420G includes internal circuitry to protect the modem from damage due to lightning strikes. However, any components placed on the Tip and Ring traces will not be protected. If you add any components between the phone jack and modem module, a surge protector such as the Teccor P3100BA Sidactor should be placed before these components to protect them from lightning damage.

## Application Note: Using a 68-Pin PLCC Socket

The XE2420G can be inserted into a socket for a 68-pin PLCC device. The HyPLCC package uses only 20 pins; 15 on one side and 5 on the opposite side. Alignment within the socket is critical for all pins of the XE2420G to make contact with the appropriate pins of the PLCC socket. The drawing below illustrates how the XE2420G fits into the 68-pin PLCC socket. Emulation Technology's S-SMT-17-068-A socket is representative of sockets that can be used with the XE2420G.

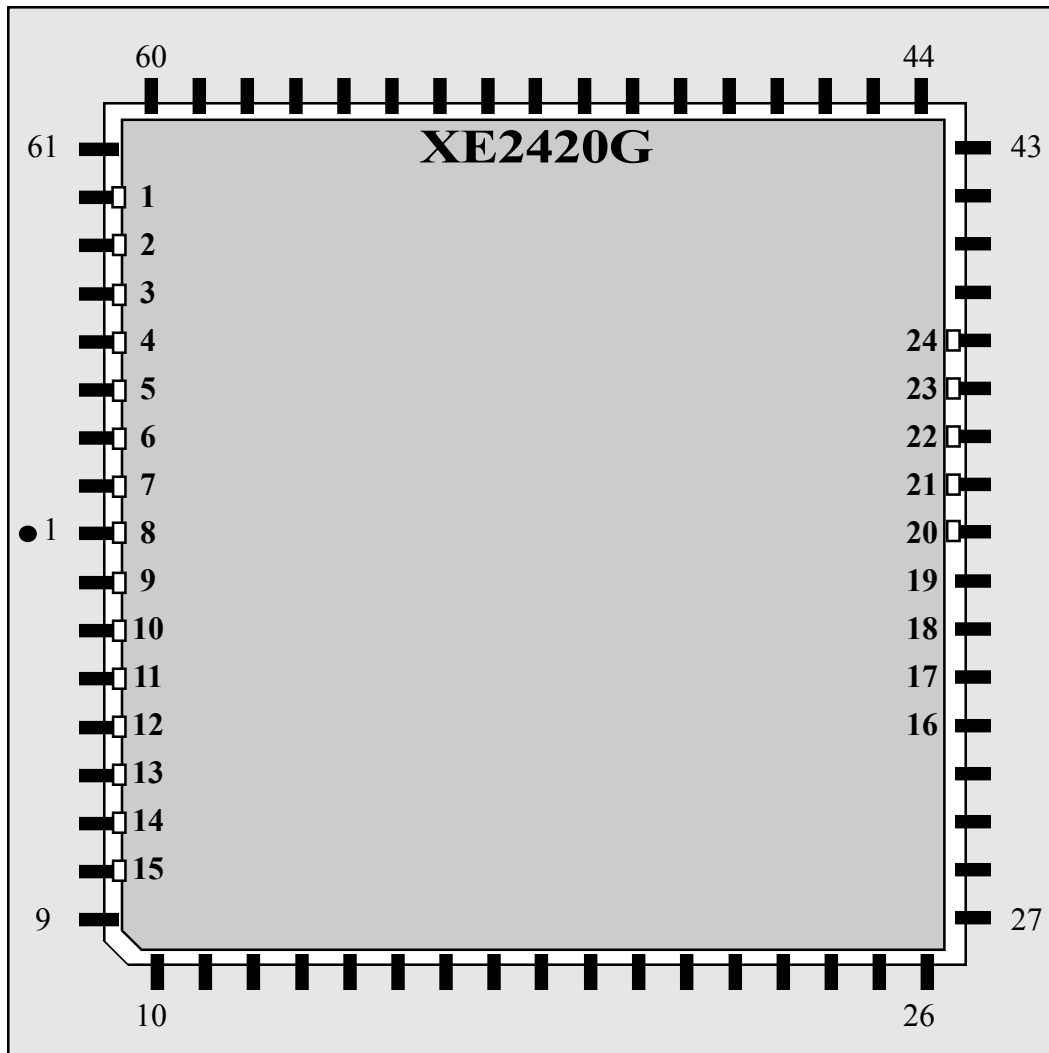



---

## **XE2420G Special Features**

The XE2420G includes special features which will be highly valuable for some applications. These features include Error Correction, Power Down Mode, Handset Interrupt, and Caller ID Decoding.

### **Error Correction:**

The XE2420G incorporates V.42 error correction. V.42 error correction incorporates two error Correction Schemes, LAPM and MNP. Either of these protocols can correct 99% of the errors which could occur in the data stream during normal transmission due to noise and line hits on the telephone line. Error correction is controlled with the AT/N command.

### **Power Down Mode:**

The primary circuits of the XE2420G can be shut down by a single command from the host, reducing power consumption to less than 50 microamps. This makes the XE2420G ideal for battery powered applications. Issuing the AT:U65,20E0<CR> command shuts down the XE2420G's modem controller and analog front end. The XE2420G can be restored to normal operation by activating the modem's RESET signal on Pin 3. The XE2420G will be fully awakened a minimum of 300 milliseconds after RESET is applied.

### **Handset Interrupt:**

The XE2420G constantly monitors the telephone line's DC loop voltage and current. When a change is detected in the electrical characteristics of the telephone line, the XE2420G activates the /INT output, Pin 13.

Upon detection of the interrupt the application host can read User Register U70 to determine the source of the interrupt. Bit 2 of that register indicates that a parallel handset has been detected. The application host can then initiate a disconnect to permit the handset to be used.

The Handset Interrupt feature prevents equipment, which shares the telephone line with a standard handset, such as a residential electrical meter, from blocking emergency calls.

### **Caller ID Decoding:**

The XE2420G can detect and pass Caller ID information to the local system host. Detection of the Caller ID information allows the application to answer calls from only known sources. When a Caller ID signal is received, the XE2420G provides the "CIDM" response to the host to acknowledge that Caller ID information is being detected. The modem's Interrupt Register, U70, can also be set to create an interrupt when Caller ID is detected.

The XE2420G decodes and passes the Caller ID characters to the application host as they are received and provides the "NO CARRIER" response to indicate when the Caller ID message is complete. The XE2420G now resumes monitoring the incoming Ring signal. If the calling number is recognized by the application host, it can initiate a connection using the ATA command.

---

## XE2420G AT Commands

The XE2420G uses "AT" commands for modem control and configuration. This section describes the AT command format and lists the AT commands, Registers and Result codes.

**Data Mode:** The XE2420G enters data mode after establishing a remote modem connection and issuing the appropriate result code. In the Data Mode the modem sends all data presented on Transmit Data (/TXD) to the remote modem and puts data from the remote modem onto Received Data (/RXD). When the modem exits data mode, it issues a "NO CARRIER" result code.

**Command Mode:** The XE2420G enters command mode on power-up, reset, a lost connection, or receipt of the escape code. In command mode the modem accepts commands from the host on transmit data. Appropriate result codes are returned on received data.

### Command Line Format

Command lines issued to the modem follow a strict format. Each command begins with the prefix AT. The command buffer stores the command line and executes it upon receipt of a carriage return. Until executed, the command line can be edited with the backspace key.

**Command Prefix** - Each command, except the A/ command, begins with the AT prefix. The "A" and "T" may be both upper case or both lower case but cannot be of different cases. The prefix identifies the speed and parity of the commands sent to the modem. The modem determines data rate by measuring the width of the incoming bits. Parity is determined by comparing the parity bits of the "A" and the "T."

**Command Line** - Commands may be strung together in a single command line of up to 48 characters. Commands are executed in the sequence they appear. Spaces may be inserted into the command line but do not fill space in the command buffer. A carriage return terminates the command line and causes the commands to be executed. Register S3 allows the user to select a character other than a carriage return to terminate the command line.

**Command Buffer** - The Command Buffer holds a maximum of 48 characters, including the AT prefix. If the command buffer overflows, the modem issues an "ERROR" result code and commands are not executed.

**Command Line Editing** - The backspace edits a command line before it is executed. The backspace key, (Control and H simultaneously on some systems), erases the previous character in the command line. Register S5 allows the user to select a character other than a backspace to edit the command line.

**Re-Execute Last Command** - The A/ command causes the modem to re-execute the last command line. This is the only command which does not require the "AT" prefix.

**Omitted Parameters** - Most commands include a parameter which determines how the functions will be set. When the command parameter is omitted from the command string, it is assumed to be a 0.

**Escape Characters** - A 3 character escape sequence may be entered to switch the modem into command mode while on line. The escape character, set by Register S2, must be entered 3 times in succession to execute the escape. An AT command must then be entered within the period defined by S12 to enter command mode. The default escape sequence is "+++."

**Result Codes** - The modem issues a result code after each action. Result codes may be sent as full words, one or two digit numeric codes, or may be disabled all together. Each result code ends with a carriage return when numeric result codes are chosen. When full word result codes are chosen, a Line Feed and Carriage Return precede and follow each result code.

## XE2420G AT Commands

An asterisk indicates the factory default

**A - Answer Command -**

**D - Dial Command -**

0-9, A-D, #, \* = Dialing Digits

P = Pulse dial

T = Tone dial

W = Wait for dial tone

, = Pause for the duration of S8

! = Switch hook flash

; = Return to the command state

**En - Command Echo**

n=0 Do not echo commands

n=1 Enable command echo \*

**Hn - Switch Hook Control -**

n=0 Switch hook relay opens

n=1 Switch hook relay closes

**In - Modem Identification**

**Mn - Speaker Activity -**

n=0 Speaker off \*

n=1 Speaker on until carrier received

n=2 Speaker remains on

n=3 Speaker on after dialing until DCD detected.

**On - On Line**

n=0 Return On Line with no retrain \*

n=1 Initiate retrain while returning On line.

n=2 Initiate rate renegotiation while returning On line.

**Qn - Responses**

n=0 Send responses \*

n=1 No Responses

**R - Initiate V.23 Reversal**

**Sr? - Interrogate Register -**

**Sr=n - Set Register Value -**

**SS - List values of all S-Registers -**

**Vn - Result Codes -**

n=0 Numeric Result Codes

n=1 English Word Result Codes\*

**Xn - Result Code Set -**

n=0 Responses 0-4

n=1 Responses 0-5 & 10

n=2 Responses 0-6 & 10

n=3 Responses 0-5, 7 & 10

n=4 Responses 0-8 & 10\*

n=5 All Responses

**Yn - Long Space Disconnect -**

n=0 Disabled\*

n=1 Modem disconnects on receipt of 1.5 seconds of continuous Space.

**Z - Reset -**

**&Hn - Protocol Selection**

n=6 V.22bis (2400 or 1200 BPS) \*

n=7 V.22 (1200 BPS)

n=8 Bell 212 (1200 BPS)

n=9 Bell 103 (300BPS)

n=10 V.21 (300 BPS)

n=11 V.23 (1200/75 BPS)

**&\$ - Display current AT& settings.**

**&Tn - Modem Test Modes**

n=0 Cancel Test Mode \*

n=3 Initiate Analog Loopback

**%On - Answer Mode**

n=0 Answer in Answer Mode \*

n=1 Answer in Originate Mode

**%%\$ - Display current AT% settings.**

**\Bn - Character Length**

n=0 6N1; Data Bits, no Parity, 1 stop bit, 1 start bit

n=1 7N1; 7 data bits, no parity, 1 start bit, 1 stop bit

n=2 7P1; 7 data bits, 1 stop bit, 1 start bit, parity determined by AT\p command.

n=3 8N1; 8 data bits, no parity bit, 1 stop bit, 1 start bit

n=5 8P1; 8 data bits, 1 stop bit, 1 start bit, parity determined by AT\p command.

n=6 8X1; 8 data bits, 1 stop bit, 1 start bit, 1 escape bit enabling 9th bit escape mode.

## XE2420G AT Commands

### **\Nn - Error Control Mode**

- n=0 Normal Mode
- n=1 MNP Required
- n=3 MNP or Normal \*
- n=4 Auto Error Correction V.42 without ODP or ADP Phase Detection, MNP or Normal mode

### **\Pn - Parity Setting**

- n=0 Even Parity selected \*
- n=1 Space Parity selected
- n=2 Odd Parity selected
- n=3 mark Parity selected

### **\Qn - Modem to DTE Flow Control**

- n=0 No Flow Control
- n=2 CTS Flow Control only \*
- n=3 RTS/CTS Flow Control
- n=4 XON/XOFF Flow Control

### **\Tn -DTE Rate**

- n=0 300 BPS
- n=1 600 BPS
- n=2 1200 BPS
- n=3 2400 BPS \*
- n=4 4800 BPS
- n=5 7200 BPS
- n=6 9600 BPS
- n=7 12.0 KBPS
- n=8 14.4 KBPS
- n=9 19.2 KBPS
- n=10 38.4 KBPS
- n=11 57.6 KBPS
- n=12 115.2 KBPS
- n=13 230.4 KBPS
- n=14 245.76 KBPS
- n=15 307.2 KBPS

### **\Vn - Connect Response**

- n=0 Issue Connect and Protocol Responses \*
- n=2 Issue Connect Response only

**:I - Read Interrupts** - Reports the lower 8 bits of User Register U70. Reading the interrupts clears them and resets the /INT pin.

**:R- Read all User Registers**

**:Rnn - Read user Register nn**

**:Unn,xxxx - Write hex value xxxx to User Register nn.**

Note multiple User Registers can be written in the same command line. Only the first register in the sequence must be addressed. Subsequent values will be loaded into successive registers. The :U command uses the format AT:Unn, xxxx, yyyy, zzzz, ...<CR> to load multiple registers.

**+VCID=n - Caller ID Enable**

- n=0 No Caller ID \*
- n=1 Formatted Caller ID Data presented
- n=2 Row Caller ID Data presented

**+VCDT=n - Caller ID Type**

- n=0 On only after first ring
- n=1 CID Always On
- n=2 UK CID Format
- n=3 Japanese CID Format

## XE2420G Country Configuration

The XE2420G can be configured to operate in countries throughout the world. The modem is configured via special U-registers. The chart on the following pages shows the register settings for the primary market countries. Note: some settings apply to many countries.

Hexidecimal register settings are read with the AT:R command and written with the AT:U command. Please contact Xecom regarding the correct register settings for countries not shown. Below is an example of the commane sequence required to change the modem configuration from its default setting to the settings for Japan.

<b>Command</b>	<b>Description</b>
ATZ<CR>	Reset configuration to factory default
ATS6=3	Set the modem to wait for 3 seconds when blind dialing
AT:U15,0030,0020<CR>	Change values of Registers U15 and U16
AT:U2C,0030,0020,06C0,1DD0,0360<CR>	Change values of Registers U2C, U2D, U2E, U2F and U30
AT:U42,0041,0021<CR>	Change values of Registers U42 and U43
AT:U45,0384<CR>	Change value of U45
AT:U67,0004<CR>	Change Value of Register U67

### Notes:

The notes below apply to the following Country Configuration Table

- 1 The congifuration labled "USA" also applies to the following countries: Canada, Columbia, Ecuador, Paraguay, Peru, Puerto Rico, South Korea, uruguay, and Venezuela.
- 2 The configuration labled CTR21 applies to all of the following countries: Algeria, Austria, Bahrain, Belgium, Croatia, Cyprus, Denmark, Estonia, finland, France, Germany, Ghana, Greece, Iceland, Ireland, Israel, Italy, Ivory Coast, Lebanon, Luxembourg, Malta, Morocco, Netherlands, Norway, Portugal, Slovenia, Spain, Switzerland, and the United Kingdom.
- 3 The configuration for russia also applies to Belarus, Kazakhstan, and the Ukraine.
- 4 Registers U42 and U43 set the make/break ratio for Pulse Dialing. Some countires including the countries conforming to CTR21 require that both a 60/40 and 67/33 ratio be supported. the chart belo shows the settings for both configurations.

<b>Make/Break Ratio</b>	<b>U42</b>	<b>U43</b>
60/40	003Dh	0027h
67/33	0041h	0021h

## XE2420G Country Configuration

The following table shows the configuration settings, in hex, for the most popular countries. The settings which are different than the modem's default values are shown in bold.

Function	Register	USA <sup>1</sup> (default)	Australia	Japan	CTR21 <sup>2</sup>	China	Russia <sup>3</sup>
<b>Dial Tone Filters</b>	<b>U00</b>	0800h	0800h	0800h	0800h	0800h	0008h
	<b>U01</b>	0000h	0000h	0000h	0000h	0000h	0000h
	<b>U02</b>	0000h	0000h	0000h	0000h	0000h	0000h
	<b>U03</b>	0000h	0000h	0000h	0000h	0000h	0000h
	<b>U04</b>	0000h	0000h	0000h	0000h	0000h	0000h
	<b>U05</b>	00A0h	00A0h	00A0h	<b>01A0h</b>	00A0h	00A0h
	<b>U06</b>	6EF1h	6EF1h	6EF1h	<b>6E79h</b>	6EF1h	6EF1h
	<b>U07</b>	C4F4h	C4F4h	C4F4h	<b>C548h</b>	C4F4h	C4F4h
	<b>U08</b>	C000h	C000h	C000h	C000h	C000h	C000h
	<b>U09</b>	0000h	0000h	0000h	0000h	0000h	0000h
	<b>U0A</b>	00A0h	00A0h	00A0h	<b>01A0h</b>	00A0h	00A0h
	<b>U0B</b>	78B0h	78B0h	78B0h	<b>7905h</b>	78B0h	78B0h
	<b>U0C</b>	C305h	C305h	C305h	<b>C311h</b>	C305h	C305h
	<b>U0D</b>	4000h	4000h	4000h	4000h	4000h	4000h
	<b>U0E</b>	B50Ah	B50Ah	B50Ah	<b>A7BE</b>	B50Ah	B50Ah
	<b>U0F</b>	0400h	0400h	0400h	<b>03A0</b>	0400h	0400h
	<b>U10</b>	70D2h	70D2h	70D2h	<b>7061h</b>	70D2h	70D2h
<b>U11</b>	C830h	C830h	C830h	<b>C8EFh</b>	C830h	C830h	
<b>U12</b>	4000h	4000h	4000h	4000h	4000h	4000h	
<b>U13</b>	80E2h	80E2h	80E2h	<b>8128h</b>	80E2h	80E2h	
<b>U14</b>	0009h	0009h	0009h	0009h	0009h	0009h	
<b>U15</b>	00A0h	<b>0030h</b>	<b>0030h</b>	00A0h	<b>0030h</b>	<b>0030h</b>	
<b>U16</b>	0070h	<b>0020h</b>	<b>0020h</b>	0070h	<b>0020h</b>	<b>0020h</b>	
<b>Busy Tone Filters</b>	<b>U17</b>	0800h	0800h	0800h	0800h	0800h	0800h
	<b>U18</b>	0000h	0000h	0000h	0000h	0000h	0000h
	<b>U19</b>	0000h	0000h	0000h	0000h	0000h	0000h
	<b>U1A</b>	0000h	0000h	0000h	0000h	0000h	0000h

## XE2420G Country Configuration

Function	Register	USA <sup>1</sup> (default)	Australia	Japan	CTR2,1 <sup>2</sup>	China	Russia <sup>3</sup>
<b>Busy Tone Filters</b>	<b>U1B</b>	0000h	0000h	0000h	0000h	0000h	0000h
	<b>U1C</b>	00A0h	00A0h	00A0h	<b>01A0h</b>	00A0h	0A00h
	<b>U1D</b>	6EF1h	6EF1h	6EF1h	<b>6E79h</b>	6EF1h	6EF1h
	<b>U1E</b>	C4F4h	C4F4h	C4F4h	<b>C548h</b>	C4F4h	C4F4h
	<b>U1F</b>	C000h	C000h	C000h	C000h	C000h	C000h
	<b>U20</b>	0000h	0000h	0000h	0000h	0000h	0000h
	<b>U21</b>	00A0h	00A0h	00A0h	<b>01A0h</b>	00A0h	00A0h
	<b>U22</b>	78B0h	78B0h	78B0h	<b>7905h</b>	78B0h	78B0h
	<b>U23</b>	C305h	C305h	C305h	<b>C311h</b>	C305h	C305h
	<b>U24</b>	4000h	4000h	4000h	4000h	4000h	4000h
	<b>U25</b>	B50Ah	B50Ah	B50Ah	<b>A7BE</b>	B50Ah	B50Ah
	<b>U26</b>	0400h	0400h	0400h	<b>03A0</b>	0400h	0400h
	<b>U27</b>	70D2h	70D2h	70D2h	<b>7061h</b>	70D2h	70D2h
	<b>U28</b>	C830h	C830h	C830h	<b>C8EFh</b>	C830h	C830h
	<b>U29</b>	4000h	4000h	4000h	4000h	4000h	4000h
	<b>U2A</b>	80E2h	80E2h	80E2h	<b>8128h</b>	802Eh	802Eh
	<b>U2B</b>	0009h	0009h	0009h	0009h	0009h	0009h
<b>U2C</b>	00A0h	<b>0030h</b>	<b>0030h</b>	00A0h	<b>0030h</b>	<b>0030h</b>	
<b>U2D</b>	0070h	<b>0020h</b>	<b>0020h</b>	0070h	<b>0020h</b>	<b>0020h</b>	
<b>Busy Tone Cadence</b>	<b>U2E</b>	0870h	<b>06C0h</b>	<b>06C0h</b>	0870h	<b>06C0h</b>	<b>06C0h</b>
	<b>U2F</b>	25F8h	<b>1DD0h</b>	<b>1DD0h</b>	25F8h	<b>1DD0h</b>	<b>1DD0h</b>
	<b>U30</b>	0438h	<b>0360h</b>	<b>0360h</b>	0438h	<b>0360h</b>	<b>0360h</b>
	<b>U31</b>	4650h	4650h	4650h	4650h	4650h	4650h
	<b>U32</b>	EF10h	EF10h	EF10h	EF10h	EF10h	EF10h
	<b>U33</b>	1200h	1200h	1200h	1200h	1200h	1200h
<b>Busy Tone Cadence</b>	<b>U34</b>	1B58h	1B58h	1B58h	1B58h	1B58h	1B58h
	<b>U35</b>	2D00h	<b>3840h</b>	2D00h	<b>0E10h</b>	<b>3840h</b>	<b>3840h</b>

## XE2420G Country Configuration

Function	Register	USA <sup>1</sup> (default)	Australia	Japan	CTR2 <sup>1, 2</sup>	China	Russia <sup>3</sup>
<b>Pulse Dialing<sup>4</sup></b>	<b>U42</b>	003Dh	003Dh	<b>0041h</b>	<b>0041h</b>	003Dh	003Dh
	<b>U43</b>	0027h	0027h	<b>0021h</b>	<b>0021h</b>	0027h	0027h
	<b>U45</b>	0320h	0320h	<b>0384h</b>	<b>0384h</b>	<b>0348h</b>	<b>0320h</b>
<b>DTMF Dialing</b>	<b>U46</b>	09B0h	<b>0680h</b>	09B0h	<b>0680h</b>	<b>08A0h</b>	<b>0680h</b>
	<b>U47</b>	0064h	0064h	0064h	<b>0090h</b>	0064h	0064h
	<b>U48</b>	0064h	0064h	0064h	<b>0090h</b>	0064h	0064h
<b>Ring Detection</b>	<b>U49</b>	0022h	0022h	0022h	0022h	0022h	0022h
	<b>U4A</b>	007Ah	<b>0089h</b>	007Ah	007Ah	007Ah	007Ah
	<b>U4B</b>	0258h	0258h	0258h	0258h	0258h	0258h
	<b>U4C</b>	6720h	6720h	6720h	6720h	6720h	6720h
<b>Bit-Mapped Register</b>	<b>U4D</b>	0000h	<b>4008h</b>	0000h	0000h	<b>4008h</b>	<b>4008h</b>
<b>Delay to Dial</b>	<b>U4E</b>	0000h	0000h	0000h	0000h	<b>1388h</b>	0000h
<b>Loop Current Debounce</b>	<b>U50</b>	015Eh	015Eh	015Eh	015Eh	015Eh	015Eh
	<b>U51</b>	00C8h	00C8h	00C8h	00C8h	00C8h	00C8h
<b>Transmit Level</b>	<b>U52</b>	0000h	<b>0001h</b>	0000h	0000h	<b>0001h</b>	<b>0001h</b>
<b>Bit-Mapped Registers</b>	<b>U67</b>	0008h	<b>0024h</b>	<b>0004h</b>	0008h	0008h	0008h
	<b>U68</b>	0000h	0000h	0000h	<b>0010h</b>	0000h	0000h
	<b>U69</b>	0006h	0006h	0006h	0006h	0006h	0006h
	<b>U77</b>	401Eh	401Eh	401Eh	401Eh	401Eh	<b>4010h</b>
<b>Dial Tone Wait</b>	<b>S6</b>	2	2	<b>3</b>	3	2	2
<b>Wait for Carrier</b>	<b>S7</b>	59	<b>50</b>	<b>50</b>	<b>50</b>	<b>50</b>	59



## XE2420G Modem S-Registers

<p>S0 <b>Answer on nth Ring:</b> S0 sets the modem to automatically answer on the nth ring. Setting S0 to 0 disables automatic answer.</p> <p>Range: 0 to 255</p> <p>Units Rings</p> <p>Default 0</p>	<p>S7 <b>Wait for Carrier after Dialing:</b> S7 determines how long the modem waits for a valid carrier signal after dialing.</p> <p>Range: 0 to 255</p> <p>Units Seconds</p> <p>Default 80</p>
<p>S1 <b>Ring Count:</b> S1 is a read-only register showing the number of rings detected. If a ring is not detected within 8 seconds, S1 is reset to zero.</p> <p>Range: 0 to 255</p> <p>Units Rings</p> <p>Default 0</p>	<p>S8 <b>Comma Pause Time:</b> S8 defines the duration of the pause initiated by a comma in the dialing string. The pause is generally used when waiting for a second dial tone.</p> <p>Range: 0 to 255</p> <p>Units Seconds</p> <p>Default 2</p>
<p>S2 <b>Escape Character:</b> S2 determines the ASCII escape character. Values of 0-127 select valid characters; values from 128 to 255 disable the escape sequence.</p> <p>Range: 0 to 255</p> <p>Units ASCII Character</p> <p>Default 43 (+)</p>	<p>S9 <b>Carrier Detect Response Time:</b> S9 establishes the length of time the remote modem's carrier must be present to be recognized as valid.</p> <p>Range: 1 to 255</p> <p>Units 0.1 Seconds</p> <p>Default 6</p>
<p>S3 <b>Line Termination Character:</b> S3 determines the ASCII character which will terminate commands and modem responses.</p> <p>Range: 0 to 127</p> <p>Units ASCII Character</p> <p>Default 13 (Carriage Return)</p>	<p>S10 <b>Carrier Off Disconnect Delay:</b> S10 selects how long carrier must be lost before the modem disconnects. Note: If S10 is smaller than the value of S9 or S10 is set to 255, the modem will not automatically disconnect on loss of carrier.</p> <p>Range: 1 to 255</p> <p>Units 0.1 Seconds</p> <p>Default 14</p>
<p>S4 <b>Line Feed Character:</b> S4 sets the ASCII character to act as a line feed character in modem responses.</p> <p>Range: 0 to 127</p> <p>Units ASCII Character</p> <p>Default 10 (Line Feed)</p>	<p>S12 <b>Escape Code Guard Timer:</b> S12 sets the escape sequence guard timer. If characters are received before or after the escape sequence, within the guard timer, the modem aborts the escape attempt and remains in data mode.</p> <p>Range: 10 to 255</p> <p>Units 0.02 Seconds</p> <p>Default 50</p>
<p>S5 <b>Backspace Character:</b> S5 defines the ASCII character used as a backspace to edit the command line.</p> <p>Range: 0 to 127</p> <p>Units ASCII Character</p> <p>Default 8 (Back Space)</p>	<p>S14 <b>Wait for Dial tone Delay:</b> S14 determines how long the modem will wait for dial tone when the W dial modifier is used.</p> <p>Range: 0 to 255</p> <p>Units Seconds</p> <p>Default 12</p>
<p>S6 <b>Dial Tone Wait Time:</b> S6 determines how long the modem waits for dial tone before dialing. The Dial Tone Wait Time cannot be set to less than two seconds.</p> <p>Range: 3 to 7</p> <p>Units Seconds</p> <p>Default 2</p>	

## XE2420G Modem S-Registers (continued)

<p>S24    <b>Sleep Inactivity Timer:</b> S24 determines the length of inactivity before the modem enters sleep mode. When set to 0, sleep mode is disabled.  Range: 0 to 255  Units: Seconds  Default: 0</p>	<p>S43    <b>Dial Attempts before Blacklisting</b> - S44 determines how many dial attempts will be allowed before Blacklisting blocks a call  Range: 0-4  Units: Number of Calls  Default: 4</p>
<p>S30    <b>Disconnect Inactivity Timer:</b> S30 controls how long the modem will remain on line with no data flowing. A 0 disables the inactivity time out.  Range: 0-255  Units: Minutes  Default: 0</p>	<p>S44    <b>Blacklisting Timer</b> - S44 sets the duration of the Blacklisting period.  Range: 0-255  Units: Seconds  Default: 180</p>
<p>S38    <b>Hang Up Delay Timer:</b> S38 determines the maximum delay between receipt of the ATH0 command and modem disconnect. .  Range: 0-255  Units: Seconds  Default: 20</p>	<p>S50    <b>Minimum Off-Hook Duration</b> - S50 determines the minimum length of time the modem will remain off-hook. An attempt to drop the line before this timer expires, will be ignored by the modem until the timer expires.  Range: 0-255  Units: Seconds  Default: 3</p>
<p>S42    <b>Blacklisting</b> - S42 controls the Blacklisting function within the XE2420G. Blacklisting regulates how frequently the modem can dial the same number. An attempt to dial beyond the limit will result in the "BLACKLISTED" result code being sent.  S42 = 0 Disabled  S42 = 1 Enabled  Default: 0</p>	

---

## **XE2420G User-Registers**

The registers described below are controlled by the AT:U command and read with the AT:R command. The user Registers that control the modem's country configuration are described elsewhere in this data sheet.

U65 **Modem Power Down:** U65 permits the XE2420G to go to power down mode to reduce power consumption for battery powered applicaitons. The modem can only be awakened by applying an active Reset signal to pin 3.

AT:U65,20E0 - Select Powerdown Mode

U70 **Modem interrupt Register:** U70 allows the user to select the events that will cause the hardware interrupt line, Pin 13, to be activated. It also stores the Interrupt status. The interrupts are cleared after this regsiter is read.

Bit 15 Activates /DTR.

Bit 14 Reserved

Bit 13 enables the on line escape sequence “+++”; Default Active!

Bit 12 Caller ID activates hardware interrupt; Default Inactive!

Bit 11 Activate interrupt on overcurrent detect; Default Inactive!

Bit 10 Parallel handset detection activates interrupt; Default Active!

Bit 9 Activate interrupt on ring detect; Default Active!

Bit 8 Activate interrupt on carrier detect; Default Active!

Bit 7 Reserved

Bit 6 Reserved

Bit 5 Reserved

Bit 4 Indicates Caller ID Detected

Bit 3 Indicates Overcurrent Detection

Bit 2 Indicates Parallel Telephone Detection

Bit 1 Indicates Ring Detection

Bit 0 indicates Carrier Detected

## **XE2420G Modem Responses**

<b><u>Digits</u></b>	<b><u>Verbose</u></b>	<b><u>Description</u></b>
0	OK	Command Successful
1	CONNECT	300 BPS or higher connection
2	RING	Ring signal detected
3	NO CARRIER	Carrier not detected
4	ERROR	Error in command line
5	CONNECT 1200	1200BPS Connection
6	NO DIAL TONE	No dial tone detected
7	BUSY	Busy signal detected
8	NO ANSWER	Remote does not answer
9	RINGING	Ringback signal detected
10	CONNECT 2400	2400 BPS Connection
30	CIDM	Caller ID Detected
31	FLASH	Hookswitch Flash detected
32	STAS	UK Caller ID Alert detected
33	X	Over current Condition
70	PROTOCOL: NONE	No Link Protocol negotiated
75	CONNECT 75	75 BPS V.23 reverse channel negotiated
77	PROTOCOL V.42	V.42 error correction protocol negotiated
80	PROTOCOL: ALTERNATE, + CLASS2	MNP2 error correction negotiated
81	PROTOCOL: ALTERNATE, + CLASS3	MNP3 error correction negotiated
82	PROTOCOL: ALTERNATE, + CLASS4	MNP4 error correction negotiated

## FCC Instructions

The XE2420G complies with Part 68 of the FCC Rules and Regulations. With each device shipped, there is a label which contains the FCC Registration Number. The FCC Registration number incorporates the Model Number, Manufacturer Identifier, Product Type identifier and Ringer Equivalence Number (REN) for this product. You must, upon request, provide this information to your telephone company. the format of the FCC REgistration Number is shown below.

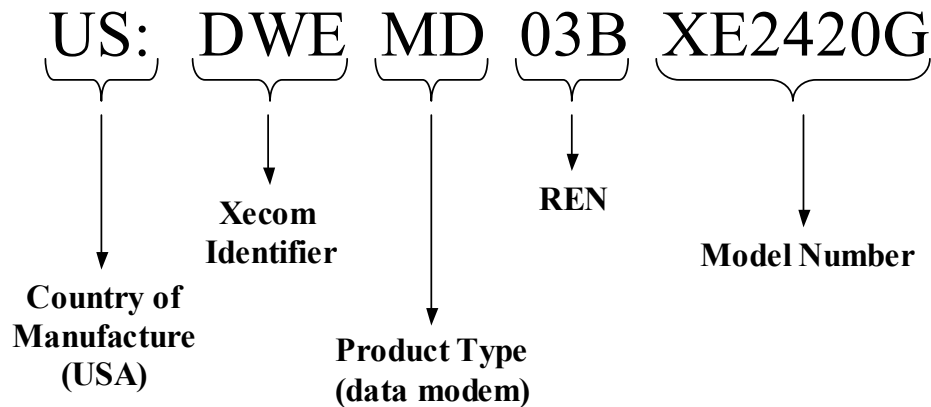

The mounting of this device in the final assembly must be made in such a manner as to preserve the high voltage protection between the TIP/RING Connection and the rest of the system. Typically, this may be accomplished by maintaining a minimum spacing 100 mils between the TIP/RING Traces to the RJ-11C Jack and low voltage portion of the system. No additional circuitry may be attached between TIP/RING and the telephone line connection, unless specifically allowed in the rules.

The REN is useful to determine the quantity of devices you may connect to a telephone line and still have all of these devices ring when the number is called. In most, but not all areas, the sum of the RENs of all devices connected to one line should not exceed five (5.0). To be certain of the number of devices you may connect to the line, as determined by the REN, you should contact the local telephone company to determine the maximum REN for you calling area.

If your system causes harm to the telephone network, the telephone company may discontinue service temporarily. If possible, they will notify you in advance. If advance notification is not practical, you will be notified as soon as possible.

Your telephone company may make changes in its facilities, equipment, operations or procedures that could affect proper functioning of your equipment. If they do, you will be notified in advance to give you an opportunity to maintain uninterrupted telephone service.

If you experience trouble with this device, please contact XECOM at (408) 945-6640 for information on obtaining service or repairs. The telephone company may ask you to disconnect this device from the network until the problem has been corrected or until you are sure that the device is not malfunctioning.

---

## Terms of Sale

Devices sold by XECOM are covered by the warranty provisions appearing in its Terms of Sale only. XECOM makes no warranty, express, statutory, implied, or by description regarding the information set forth herein, or regarding the freedom of the described devices from patent infringement. XECOM makes no warranty of merchantability or fitness for any purposes. XECOM reserves the right to discontinue production and change specifications and prices at any time and without notice. This product is intended for use in normal commercial applications. Applications requiring extended temperature range, unusual environmental requirements, or high reliability applications, such as military, medical life-support or life-sustaining equipment, are specifically not recommended without additional processing and authorization by XECOM for such application.

Xecom assumes no responsibility for the use of any circuitry other than circuitry embodied in a Xecom product. No other circuits, patents, or licenses are implied.

## Life Support Policy

Xecom's products are not authorized for use as Critical Components in Life Support Devices or Systems.

**Life Support Devices or Systems** are devices or systems which, (a) are intended for surgical implant into the body, or (b) support or sustain life, and whose failure to perform, when properly used in accordance with instructions provided in the labeling, can be reasonably expected to result in significant injury to the user.

**A Critical Component** is any component of a life support device or system whose failure to perform can be reasonably expected to cause failure of the life support device or system, or to affect its safety or effectiveness.

Copyright, Xecom © 2003

While Xecom, Inc. has made every effort to ensure that the information presented here is accurate, Xecom will not be liable for any damages arising from errors or omission of fact. Xecom reserves the right to modify specifications and/or prices without notice. Product mentioned herein are used for identification purposes only and may be trademarks and/or registered trademarks of their respective companies.

**xecom**<sup>®</sup>

**Xecom Incorporated**  
374 Turquoise Street, Milpitas, CA 95035  
Ph:408-942-2200 Fax:408-942-1346 E-Mail: [info@xecom.com](mailto:info@xecom.com)

## X-ON Electronics

Largest Supplier of Electrical and Electronic Components

*Click to view similar products for [Telecom Interface Ics](#) category:*

*Click to view products by [Cermetek Microelectronics](#) manufacturer:*

Other Similar products are found below :

[82P2821BHG](#) [MT8888CP1](#) [MT9174AN1](#) [LC850541-E](#) [SI3010-F-FSR](#) [M83262G13](#) [MT8870DNR1](#) [MT88E39ASR1](#) [MT9074AL1](#)  
[MT9122AP1](#) [82V2082PFG8](#) [WPCS6051C.B0-900246](#) [MT9074AP1](#) [DS34S102GN+](#) [DS3150TNC1+](#) [DS33X11+](#) [Si3050-E1-FTR](#)  
[XRT6164CD-F](#) [DS26334GN+](#) [PM4351-NGI](#) [PM5384-NGI](#) [MT88E46AS1](#) [MT8963AE1](#) [MT9076BP1](#) [LE88231DLC](#) [DS26324GNA3+](#)  
[82P2521BHG](#) [PM8310A-FEI](#) [PM4351-RI](#) [DS21354LB+](#) [PEF41068FV11 S LL8T](#) [LE9632RQC](#) [LE9622RQC](#) [LE9653AQC](#) [SI3050-E1-GTR](#)  
[PEF41068VV12 S LL8U](#) [LE58QL022BVC](#) [LE58QL022BVCT](#) [SI32260-C-FM1R](#) [SI32392-B-GM](#) [82P2917ABBG](#) [SI3019-F-GSR](#)  
[EELXT914PC.B3 865795](#) [LE88266DLC](#) [LCP22-150B1RL](#) [W7100A-S2E-100LQFP](#) [USR5686G](#) [MT88L70AS1](#) [DS34S104GN](#) [DS21554L](#)