

UMK-BE 22,5

Order No.: 2970028

The illustration shows a combination of versions UMK SE 11,25, UMK BE 11,25,- 22,5, -45 and UMK-FE



<http://eshop.phoenixcontact.co.uk/phoenix/treeViewClick.do?UID=2970028>

Electronic board base, plug-in module base element

Commercial data

EAN	 4 017918 087555
Pack	10
Customs tariff	85472000
Gross weight in pieces	9.60 g
Country of Origin	PL
Catalog page information	Page 760 (CAT-1-2013)

Product notes

WEEE/RoHS-compliant since:
01/01/2003



Please note that the data given here has been taken from the online catalog. For comprehensive information and data, please refer to the user documentation at <http://www.download.phoenixcontact.com>. The General Terms and Conditions of Use apply to Internet downloads.

Technical data

General

Housing type	Panel mounting base
Housing material	Polyamide
Color	green

Ambient conditions

Ambient temperature (operation)	-40 °C ... 105 °C
---------------------------------	-------------------

Dimensions

Length	77 mm
Width	22.5 mm

Technical data

Inflammability class according to UL 94	V2
---	----

Certificates



Certification UL Recognized

Certifications applied for:

Certification Ex:

Accessories

Item	Designation	Description
------	-------------	-------------

Assembly

2976077	UMK-BF	Mounting flange, for mounting directly on the wall
---------	--------	--

General

2971535	UMK-BE 11,25	Electronic board base, plug-in module base element
2970015	UMK-BE 45	Electronic board base, plug-in module base element
2970031	UMK-FE	Foot element, for mounting on DIN rail NS 32 or DIN rail NS 35/7.5, can be inserted between base and side element

Drawings

Dimensioned drawing

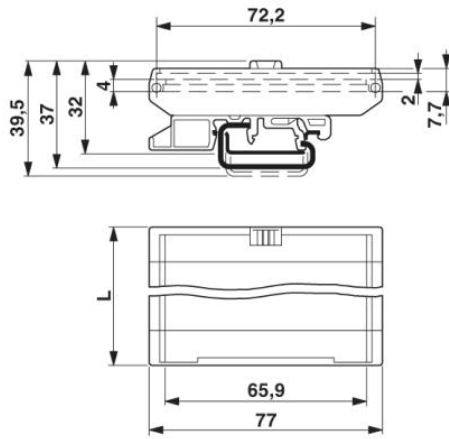

Address

PHOENIX CONTACT Ltd
Halesfield 13
Telford / Shropshire / TF7 4PG, England
Phone 01952 681 700
Fax 01952 681 799
<http://www.phoenixcontact.co.uk>



Phoenix Contact Ltd.
Technical modifications reserved;

X-ON Electronics

Largest Supplier of Electrical and Electronic Components

Click to view similar products for [phoenix contact manufacturer](#):

Other Similar products are found below :

[1203259](#) [3240366](#) [1893300](#) [2800744](#) [2867076](#) [3006564](#) [2800741](#) [5146480](#) [1582539](#) [1623633](#) [1507793](#) [3025587](#) [3069708](#) [1582223](#)
[1431461](#) [1586976](#) [0311647](#) [1460160](#) [1771338](#) [3048387](#) [2814605](#) [0309086](#) [1513716](#) [3035684](#) [5451417](#) [0202219](#) [1647747](#) [1730667](#)
[1709267](#) [5449018](#) [0311634](#) [1730696](#) [3034057](#) [0311579](#) [1730683](#) [0719032](#) [5449843](#) [3240098](#) [0311566](#) [0201391](#) [CRIMPFOX 16 S](#)
[CRIMPFOX 25R](#) [CRIMPSET 25](#) [7001438](#) [ETD-BL-1T-F-300S](#) [MCR-1CLP-I-I-00](#) [MCR-4CLP-I-I-00](#) [MCR-DAC 8-I- 4-BUS](#) [FL EPA](#)
[WMS](#) [FLK 50/EZ-DR/ 400/KONFEK/S](#)