

**Proven
Reliability**

C SERIES

MINIATURE, REGULATED HIGH VOLTAGE DC TO DC CONVERTERS

100V to 8kV at 1W

**NOW
UL RECOGNIZED**



PRODUCT DESCRIPTION

Miniature, well-regulated high voltage power supplies provide clean and reliable high voltage in a shielded, PC-mount package. Featuring precision 0 to 100% programmability and very low ripple and EMI/RFI, these cost-effective power supplies are ideal for integration into compact, sensitive equipment. For 10kV output, see the CB Series.

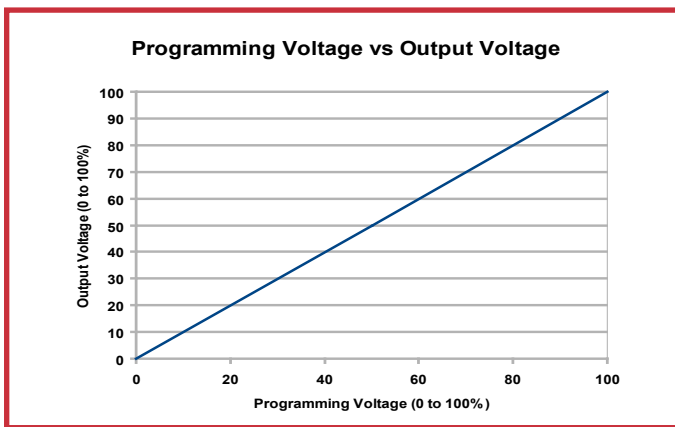

APPLICATIONS

- Photomultiplier Tubes
- Solid State Detectors
- Electrophoresis
- Piezo Devices
- Capacitor Charging
- EO Lenses

OPTIONS

- Flying Lead: Available for Models C01 through C20 (FL Suffix)

PRODUCT SELECTION TABLE

MODEL	OUTPUT VOLTAGE	MAXIMUM OUTPUT CURRENT*1
C01	0 to 100V	0 to 10mA
C02	0 to 200V	0 to 5mA
C03	0 to 300V	0 to 3.3mA
C05	0 to 500V	0 to 2mA
C06	0 to 600V	0 to 1.67mA
C10	0 to 1kV	0 to 1mA
C12	0 to 1.25kV	0 to 1mA
C15	0 to 1.5kV	0 to 0.67mA
C20	0 to 2kV	0 to 0.5mA
C25	0 to 2.5kV	0 to 0.4mA
C30	0 to 3kV	0 to 0.33mA
C40	0 to 4kV	0 to 0.25mA
C50	0 to 5kV	0 to 0.2mA
C60	0 to 6kV	0 to 0.166mA
C80	0 to 8kV	0 to 0.125mA

Complete List of Models on page 2

FEATURES

- Regulated
- Low-Noise, Quasi-Sinewave Oscillator
- Miniature Size
- 0 to 100% Programmable Output
- High Stability: <50ppm/°C (Typical)
- Wide Input Voltage Range: 11.5 to 16V
- Very Low EMI/RFI
- High Reliability: MTBF >2.6 Million Hours per Bellcore TR-332 (Model C10)
- Steel Case with Isolated Case Ground
- Sealed to Withstand Immersion Cleaning Process
- External Gain Adjust for Calibration
- UL 94V-0 Listed Proprietary Encapsulant
- RoHS Compliant

ISO 9001:2008
CERTIFIED

ISO 14001:2004
CERTIFIED

RoHS
COMPLIANT

UL US
E344664

CE

IPC
Certified J-STD-001
Application Specialist

ELECTRICAL SPECIFICATIONS*2 C01 - C80 (100V to 8kV)

OUTPUT VOLTAGE (POSITIVE OR NEGATIVE)	MODEL	MAXIMUM OUTPUT CURRENT*1	RIPPLE P-P FULL-LOAD*3	REGULATION		FREQUENCY*3
				LOAD 0 TO 100%*3	LINE 11.5 TO 16.0V*3	
0 to +100V	C01	0 to 10mA	<0.75 %	<0.1%	<0.1 %	200 - 250kHz
0 to +200V	C02	0 to 5mA	<0.05 %	<0.1%	<0.1 %	250 - 350kHz
0 to -200V	C02N	0 to 5mA	<0.05 %	<0.1 %	<1 %	75 - 150kHz
0 to +300V	C03	0 to 3.3mA	<0.03 %	<0.1 %	<0.1 %	200 - 300kHz
0 to +500V	C05	0 to 2mA	<0.004 %	<0.07 %	<0.1 %	250 - 350kHz
0 to -500V	C05N	0 to 2mA	<0.005 %	<0.5 %	<0.5 %	200 - 350kHz
0 to +600V	C06	0 to 1.67mA	<0.003 %	<0.1 %	<0.1 %	250 - 300kHz
0 to -600V	C06N	0 to 1.67mA	<0.003 %	<0.75 %	<0.75 %	125 - 300kHz
0 to +1,000V	C10	0 to 1mA	<0.005 %	<0.3 %	<0.3 %	200 - 250kHz
0 to -1,000V	C10N	0 to 1mA	<0.002 %	<0.5 %	<0.3 %	100 - 125kHz
0 to +1,250V	C12	0 to 1mA	<0.004 %	<0.1 %	<0.1 %	200 - 250kHz
0 to -1,250V	C12N	0 to 1mA	<0.003 %	<0.175 %	<0.1%	100 - 125kHz
0 to +1,500V	C15	0 to 0.67mA	<0.002 %	<0.1 %	<0.1 %	100 - 125kHz
0 to -1,500V	C15N	0 to 0.67mA	<0.002 %	<0.2 %	<0.2 %	75 - 100kHz
0 to +2,000V	C20	0 to 0.5mA	<0.002 %	<0.15 %	<0.1 %	75 - 100kHz
0 to -2,000V	C20N	0 to 0.5mA	<0.002 %	<0.15%	<0.1 %	75 - 100kHz
0 to +2,500V	C25	0 to 0.4mA	<0.1 %	<0.3 %	<0.2 %	125 - 150kHz
0 to -2,500V	C25N	0 to 0.4mA	<0.2 %	<0.5 %	<0.2 %	125 - 150kHz
0 to +3,000V	C30	0 to 0.33mA	<0.1 %	<0.3 %	<0.05 %	75 - 100kHz
0 to -3,000V	C30N	0 to 0.33mA	<0.2 %	<0.3 %	<0.075 %	75 - 100kHz
0 to +4,000V	C40	0 to 0.25mA	<0.1 %	<0.25 %	<0.2 %	50 - 125kHz
0 to -4,000V	C40N	0 to 0.25mA	<0.1 %	<0.2 %	<0.1 %	75 - 150kHz
0 to +5,000V	C50	0 to 0.2mA	<0.1%	<0.35%	<0.1%	75 - 150kHz
0 to -5,000V	C50N	0 to 0.20mA	<0.1 %	<0.25%	<0.1%	125 - 175kHz
0 to +6,000V	C60	0 to 0.166mA	<0.1 %	<0.25%	<0.1 %	125 - 175kHz
0 to -6,000V	C60N	0 to 0.166mA	<0.1 %	<0.25%	<0.15 %	125 - 175kHz
0 to +8,000V	C80	0 to 0.125mA	<0.2 %	<0.75%	<0.15 %	100 - 150kHz
0 to -8,000V	C80N	0 to 0.125mA	<0.2 %	<0.75%	<0.25 %	100 - 150kHz

ELECTRICAL SPECIFICATIONS^{*2} C01 - C80 (100V to 8kV)

PARAMETER	VALUE
INPUT VOLTAGE	+11.5 to +16V
INPUT CURRENT	<100mA, NO LOAD
	<250mA, FULL LOAD
INPUT CAPACITANCE	440uF LOW ESR
PROGRAMMING VOLTAGE	0 to +5V, <100uA
RESPONSE TIME	<250msec (FULL LOAD, FULL-SCALE RESPONSE)
SETPOINT ACCURACY ⁶	+/-1%
GAIN ADJUST ⁶	5 to 10%
LINEARITY ⁶	<1% (15% to 100% Vout)
STABILITY	<0.01% / HOUR
TEMPCO	<50PPM / °C ³
THERMAL SHOCK LIMIT	1°C / 10 SECONDS
OPERATING TEMPERATURE	-10 to +60°C ⁵ (CASE)
STORAGE TEMPERATURE	-20 to +90°C

DETAILED PRODUCT DESCRIPTION

The C Series is a line of miniature, regulated high voltage power supplies. Each model is programmed from 0 to 100% of rated output via a 0 to +5 volt, DAC-compatible, high-impedance programming input voltage. Temperature drift is typically less than 50ppm/°C. These modules exhibit very low ripple, noise, and EMI/RFI by utilizing a quasi-sinewave oscillator, shielded transformer, excellent filtering techniques and an isolated steel enclosure featuring a separate grounding pin. An externally accessible potentiometer provides adjustable gain trim, allowing for individual calibration of units. A proprietary encapsulation process and a custom 94V-0 listed, high-performance formula are used to achieve excellent high voltage and thermal properties. Positive and negative outputs are standard, and delivery of small quantities is available from stock.

Also available with the C Series are the CM Series adapter kits. For more details, refer to pages 10 and 11.

Small quantities are available from stock from our factory or our stocking distributor in Switzerland, Condatas AG. For large quantity requests, please consult our factory or our stocking distributor in Switzerland, Condatas AG.

MECHANICAL SPECIFICATIONS C01 to C20 (100V to 2kV)

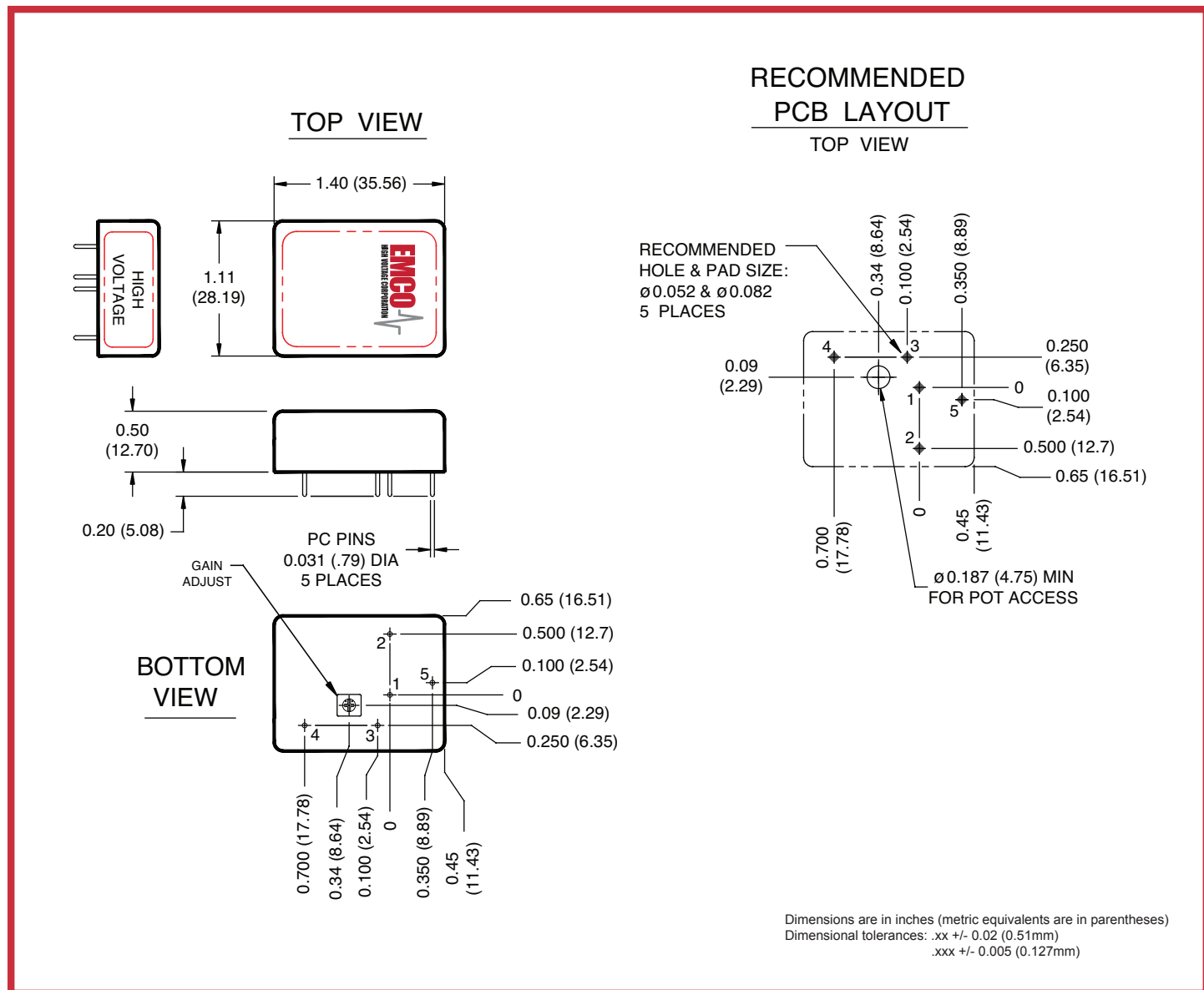

PARAMETER	VALUE
WEIGHT	1.1 OUNCES (31.0 GRAMS)
VOLUME	0.77 CUBIC INCHES (12.62 CUBIC CENTIMETERS)
DIMENSIONS	1.40L (35.56L) x 1.11W (28.19W) x 0.50H (12.70H)
CASE MATERIAL	ZINC PLATED STEEL

PIN #	FUNCTION
1	(+) INPUT
2	GROUND
3	PROGRAMMING VOLTAGE
4	HV OUT
5	CASE GROUND ⁴

MECHANICAL SPECIFICATIONS C25 to C40 (2.5kV to 4kV)

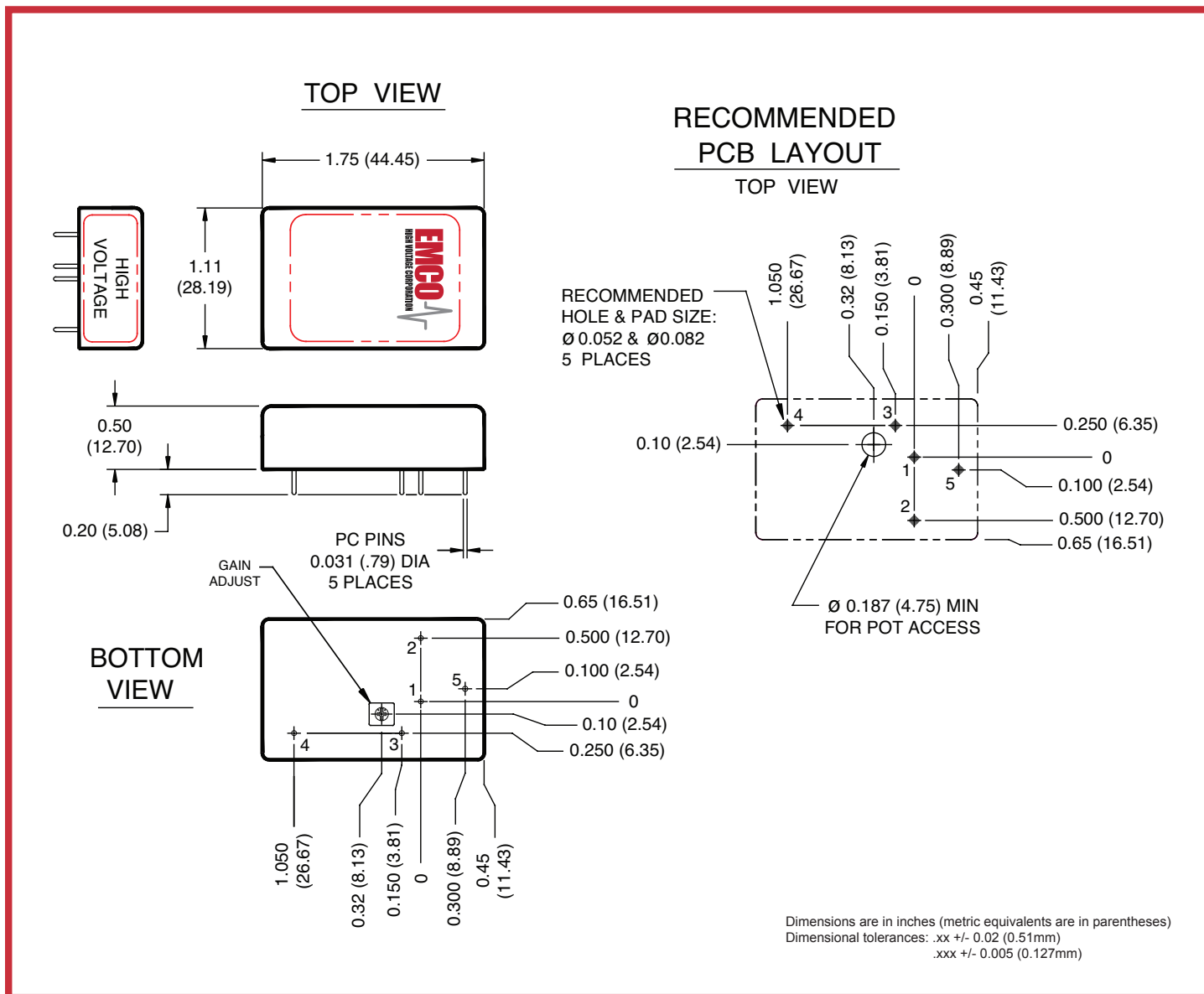

PARAMETER	VALUE
WEIGHT	1.3 OUNCES (36.8 GRAMS)
VOLUME	0.96 CUBIC INCHES (15.77 CUBIC CENTIMETERS)
DIMENSIONS	1.75L (44.45L) x 1.11W (28.19W) x 0.50H (12.70H)
CASE MATERIAL	ZINC PLATED STEEL

PIN #	FUNCTION
1	(+) INPUT
2	GROUND
3	PROGRAMMING VOLTAGE
4	HV OUT
5	CASE GROUND ⁴

MECHANICAL SPECIFICATIONS C50 to C60 (5kV to 6kV)

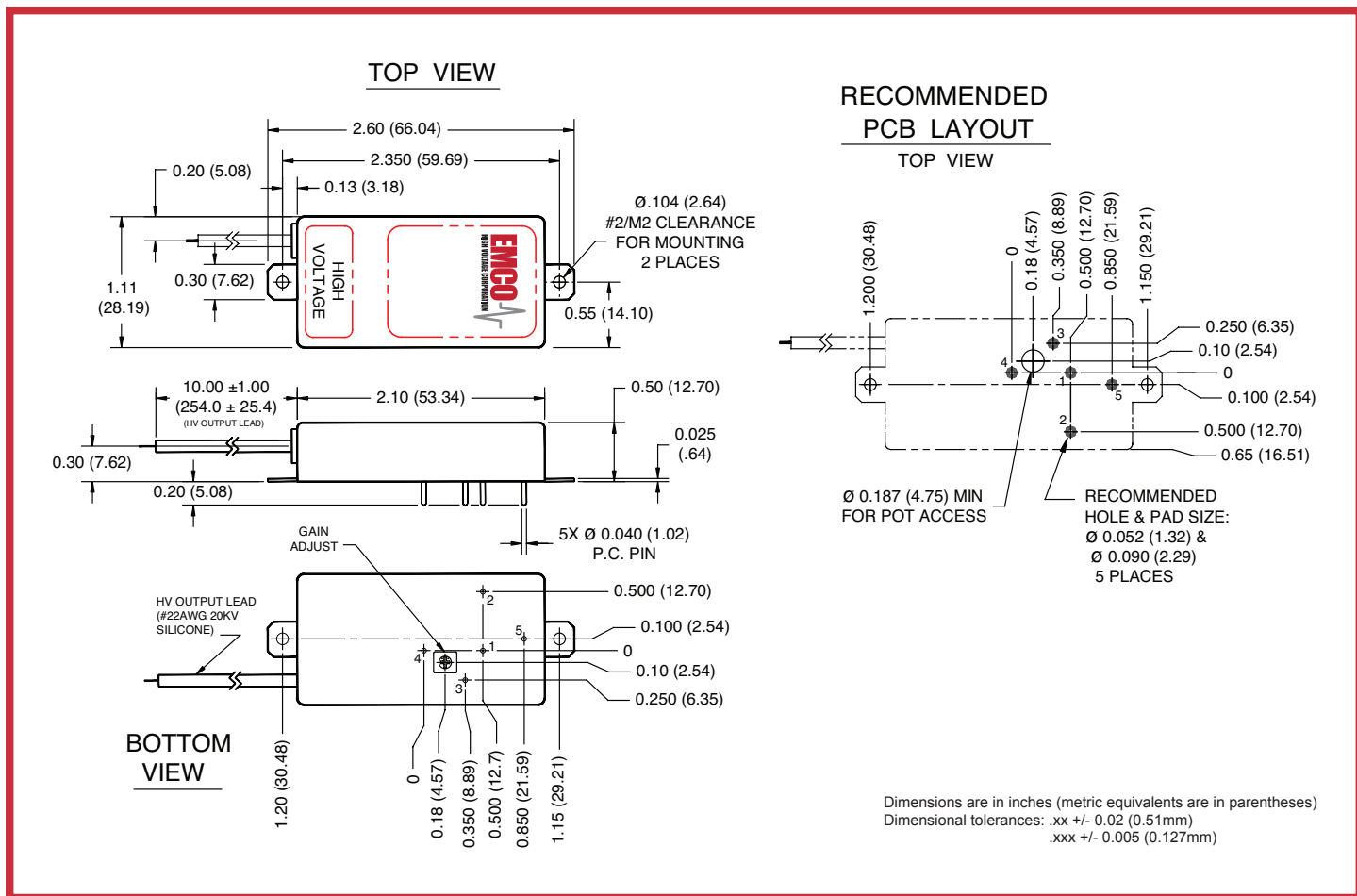

PARAMETER	VALUE
WEIGHT	1.8 OUNCES (50.9 GRAMS)
VOLUME	1.16 CUBIC INCHES (18.93 CUBIC CENTIMETERS)
DIMENSIONS	2.10L (53.34L) x 1.11W (28.19W) x 0.50H (12.70H)
CASE MATERIAL	ZINC PLATED STEEL

PIN #	FUNCTION
1	(+) INPUT
2	GROUND
3	PROGRAMMING VOLTAGE
4	HV RETURN
5	CASE GROUND
LEAD	HV OUT

MECHANICAL SPECIFICATIONS C80 (8kV)

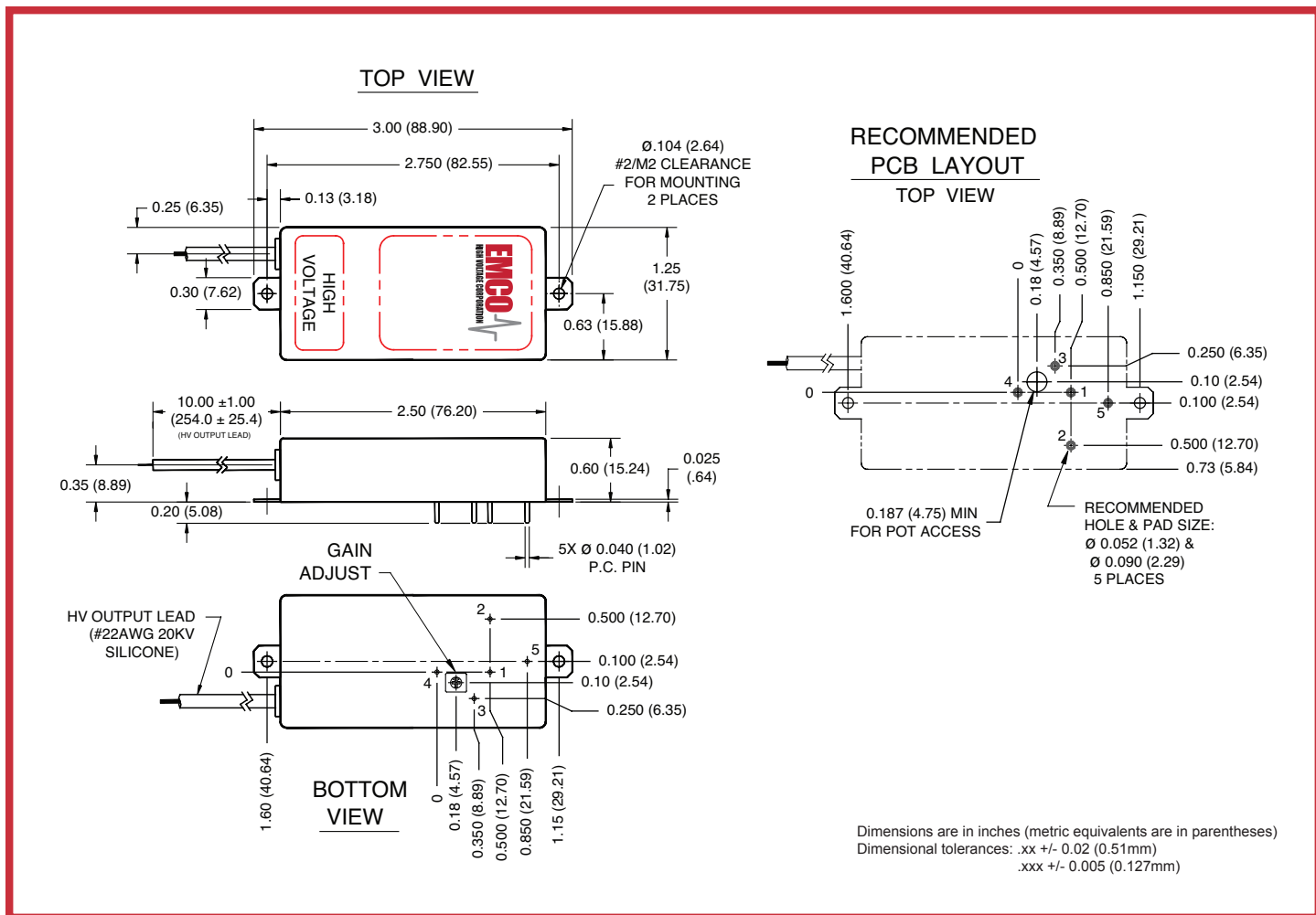

PARAMETER	VALUE
WEIGHT	2.0 OUNCES (56.6 GRAMS)
VOLUME	1.88 CUBIC INCHES (30.73 CUBIC CENTIMETERS)
DIMENSIONS	2.50L (76.20L) x 1.25W (31.75W) x 0.60H (15.24H)
CASE MATERIAL	ZINC PLATED STEEL

PIN #	FUNCTION
1	(+) INPUT
2	GROUND
3	PROGRAMMING VOLTAGE
4	HV RETURN
5	CASE GROUND
LEAD	HV OUT

MECHANICAL SPECIFICATIONS C01-C20 - Flying Lead Option (100V TO 2kV)

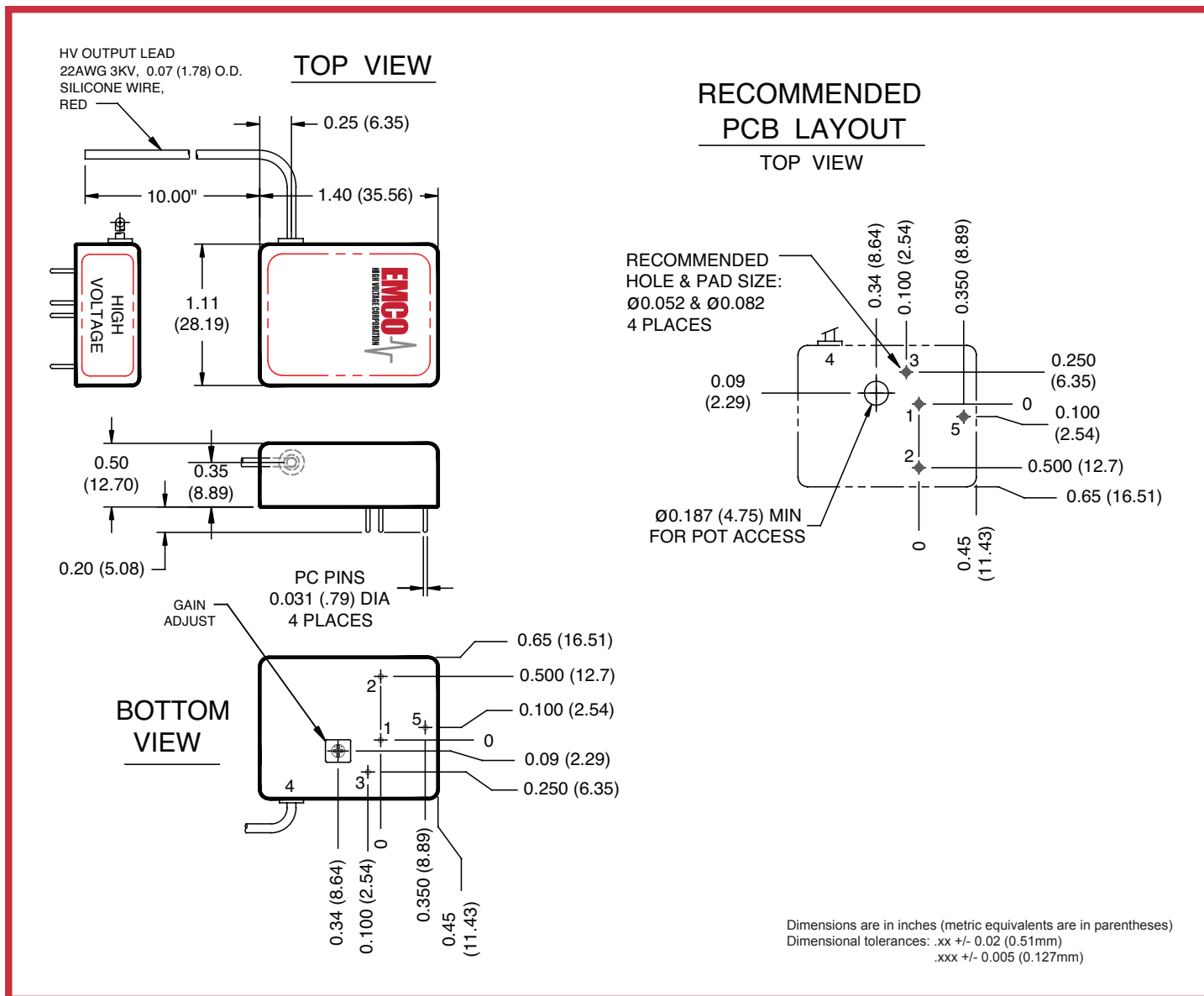

PARAMETER	VALUE
WEIGHT	1.1 OUNCES (31.0 GRAMS)
VOLUME	0.77 CUBIC INCHES (12.62 CUBIC CENTIMETERS)
DIMENSIONS	1.40L (35.56L) x 1.11W (28.19W) x 0.50H (12.70H)
CASE MATERIAL	ZINC PLATED STEEL

PIN #	FUNCTION
1	(+) INPUT
2	GROUND
3	PROGRAMMING VOLTAGE
4	CASE GROUND ⁴
LEAD	HV OUT

APPLICATION NOTES

Improved Performance and Protection

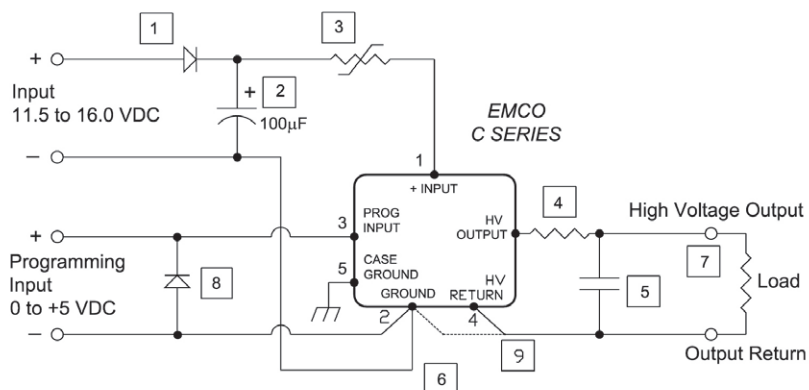

- 1 Diode provides reverse polarity protection.
- 2 Capacitor reduces ripple.
- 3 Resettable fuse (Raychem P/N RXE020,025 or 030) provides indefinite short circuit protection. *Selection depends on model used, load characteristics and operating temperature range.*
- 4 Series resistance increases arc protection and reduces ripple (when used with an output capacitor).
- 5 Capacitor reduces ripple.
- 6 IMPORTANT: Keep Input, Programming and Output return paths separate to eliminate ground loop accuracy errors.
- 7 Conformal coating recommended on all exposed high voltage conductors.
- 8 Diode provides protection against negative programming voltage or negative transient spike.
- 9 Output circuit return to HV return (pin 4) on C50 - C80. On C01-C40, output circuit return to ground (pin 2).

CM3: MODELS C25, C25N, C30, C30N, C40 and C40N

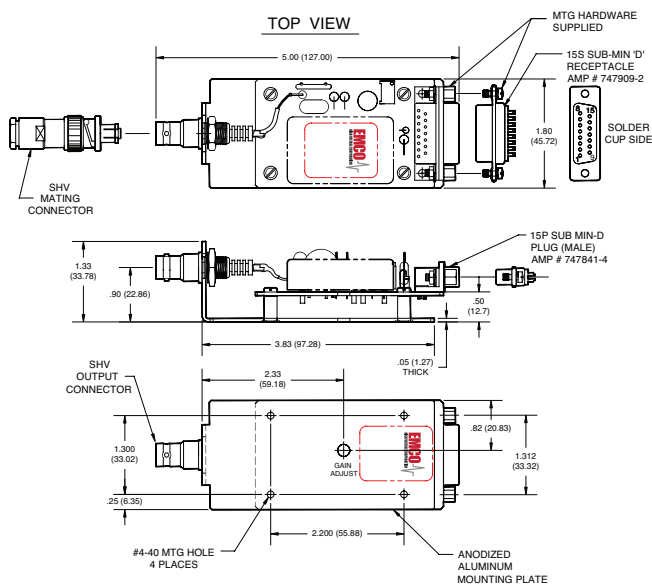

Dimensions are in inches (metric equivalents are in parentheses)
 Dimensional tolerances: .xx +/- 0.02 (0.51mm)
 .xxx +/- 0.005 (0.127mm)

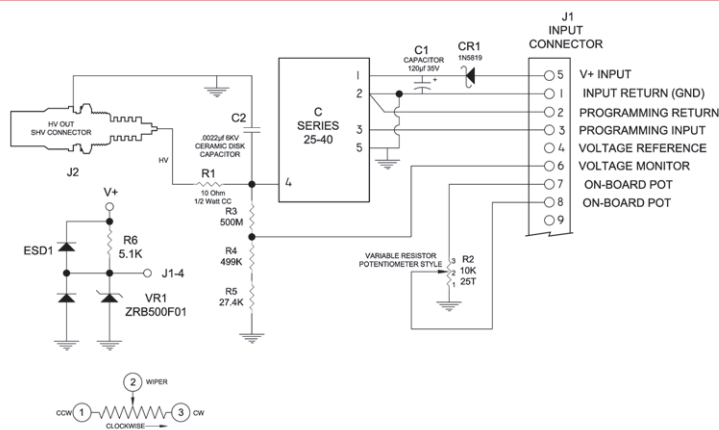

PRODUCT DESCRIPTION

These adapters provide convenient prototyping and evaluation during system development and integration. They allow C Series modules to be mounted to a chassis instead of designed into a PC board.

Extra filtering on the input and output improves performance. A schottky diode on the input provides reverse polarity protection. Input connector is via a 15P SUB MIN-D plug (mate supplied) and output is via an SHV style coaxial connector (mate supplied).

ORDERING INFORMATION:

Please note when ordering a CM3 the C Series is not included and must be ordered separately.

PROGRAMMING INSTRUCTIONS

- **Onboard Potentiometer:** connect pins 7 to 4 and 8 to 3, turn potentiometer to adjust high voltage.

OR

- **Remote Potentiometer:** connect wiper arm to pin 3, other sides to pins 4 and 2.

OR

- **Remote Analog Signal:** apply programming voltage to pin 3, return to pin 2.

CM4: MODELS C50, C50N, C60, C60N, C80 and C80N

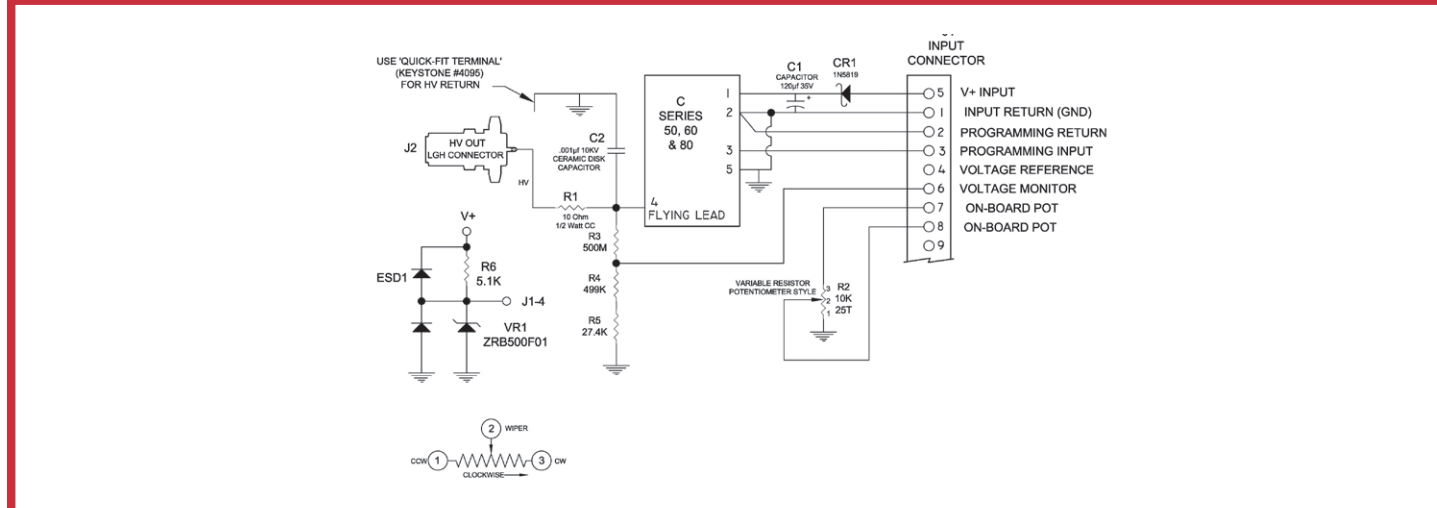
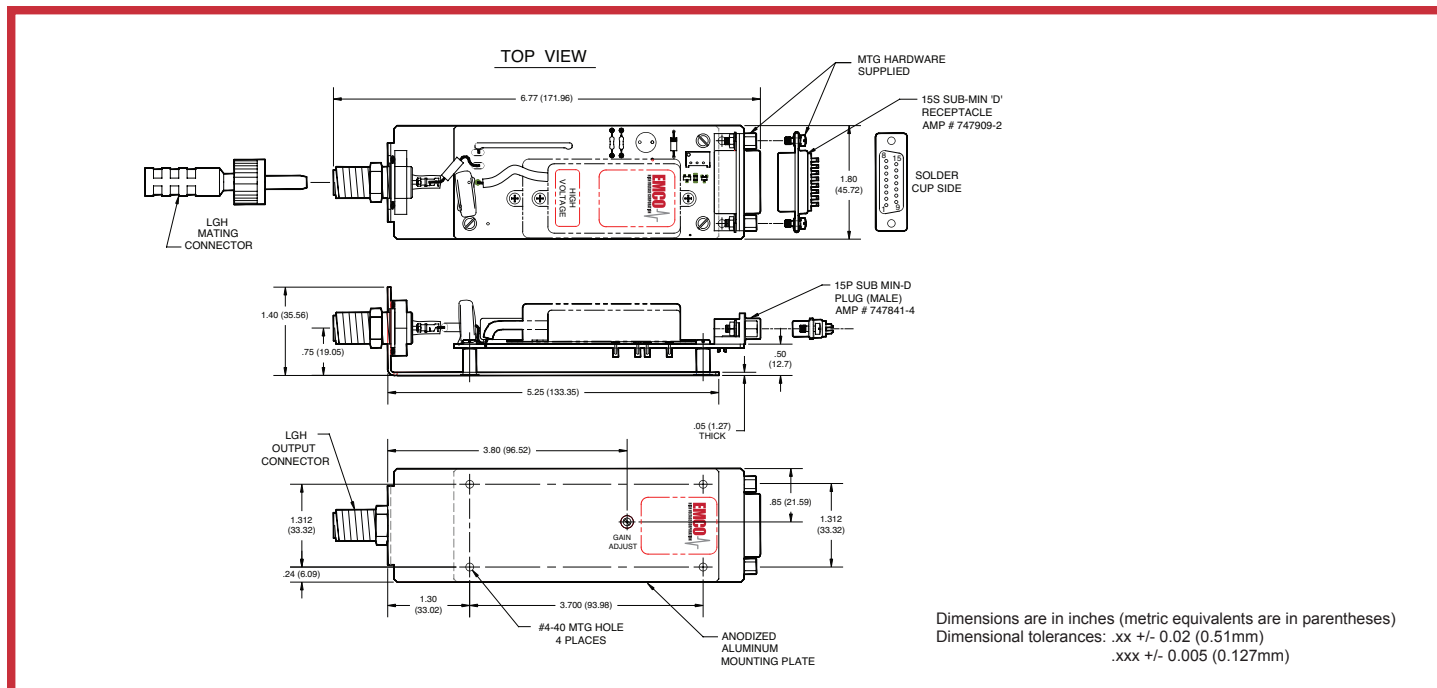

PRODUCT DESCRIPTION

These adapters provide convenient prototyping and evaluation during system development and integration. They allow C Series modules to be mounted to a chassis instead of designed into a PC board.

Extra filtering on the input and output improves performance. A schottky diode on the input provides reverse polarity protection. Input connector is via a 15P SUB MIN-D plug (mate supplied) and output is via an LGH style coaxial connector (mate supplied).

ORDERING INFORMATION:

Please note when ordering a CM4 the C Series is not included and must be ordered separately.

PROGRAMMING INSTRUCTIONS

- **Onboard Potentiometer:** connect pins 7 to 4 and 8 to 3, turn potentiometer to adjust high voltage.

OR

- **Remote Potentiometer:** connect wiper arm to pin 3, other sides to pins 4 and 2.

OR

- **Remote Analog Signal:** apply programming voltage to pin 3, return to pin 2.

BLOCK DIAGRAM

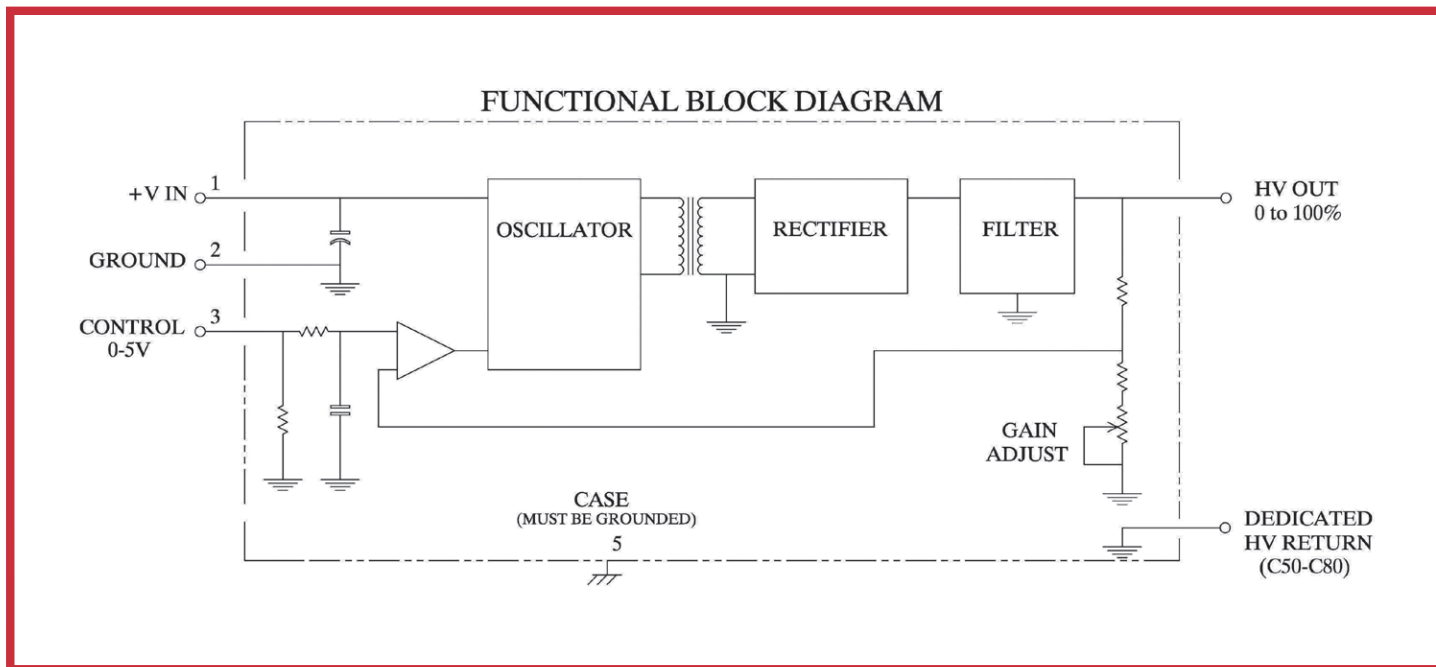

HOW TO ORDER

PART NUMBER SELECTOR:

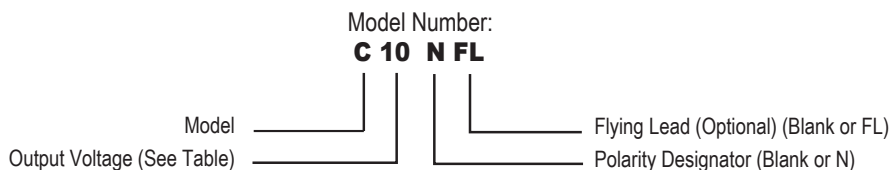

EXAMPLE: **C10N** (C-Series, **10** - Output Voltage, **N** - Negative, **FL** - Flying Lead (Optional))

- * Notes:
1. At maximum rated output voltage.
 2. Specifications after 1 hour warm-up, full load, at 25°C unless otherwise indicated.
 3. Typical performance
 4. All grounds internally connected except case. There should not be more than 50 volts potential between the case ground (pin 5) and the circuit ground (pins 3 and 8). Isolated case assists low-noise design efforts. Case pin must be connected to ground for proper operation.
 5. Proper thermal management techniques are required to maintain safe case temperature at maximum power output.
 6. SET-POINT ACCURACY refers to the ability of the unit to accurately deliver the voltage intended by the applied programming. The resultant output voltage will be within +/-1% of that programmed.
- GAIN ADJUSTMENT refers to the ability to alter the gain of the circuit to bring the resultant output voltage to the programmed set point. This is intended to allow compensation for set-point accuracy error.
- LINEARITY refers to how much the transfer function can deviate from a straight line in the absence of any set-point error.

XP-EMCO reserves the right to make changes on products and literature, including specifications, without notice. XP-EMCO standard product models are not recommended for "copy-exact" applications or any other application restricting product changes. "Copy-exact" options are available. Please contact an XP-EMCO sales representative for more details.

X-ON Electronics

Largest Supplier of Electrical and Electronic Components

Click to view similar products for [sprecher+schuh](#) manufacturer:

Other Similar products are found below :

[D5M-PL33TL5](#) [CA7-23-M22-120](#) [CA7-60-00-24Z](#) [CA7-72-00-24Z](#) [CA7-PV-S22](#) [CA8-9C-01-24D](#) [SAS3-75-1](#) [CS7-22E-480](#) [CA372-240](#)
[CA7-43-10-120](#) [CA7-85-00-24Z](#) [CAT7-23-480-MF](#) [D5P-LU2C233DL5-X11](#) [CEP7-M32-0.32-10](#) [SR7-SH40GA12](#) [CA8-9C-10-24D](#) [RZ7-](#)
[FEB3TU23](#) [CA7-16-10-208](#) [CA7-43E-10-24E](#) [CS7-31E-480](#) [D5M-PL43TL5](#) [SR7-SH25GZ25](#) [D5P-SM32](#) [L8-20/3/D](#) [CA7-30-00-240](#) [CA7-](#)
[37-00-24Z](#) [CS7-PV-02](#) [LE7-80-1753](#) [KTA7-25S-4A](#) [CA8-09C-01-120D](#) [CA8-09C-01-110D](#) [KTA7-25S-1.6A](#) [CA7-37E-10-24E](#) [CA7-](#)
[30-01-24Z](#) [CA8-09-01-240](#) [CA7-12-10-240](#) [CA7-43-01-120](#) [LE7-100-1753](#) [CM3](#) [SR7-SH25GA12](#) [KTA7-25S-2.5A](#) [GQ-50-24-D-1-4](#) [GQ-](#)
[50-24-A-1-4](#) [GQ-90-60-A-1-4](#) [CS8C-22Z-110D](#) [CS7-40E-120V](#) [CT7-75-30](#) [CA7-85-00-120](#) [CA8-09-10-208](#) [XESP2021](#)