

## 1 INTRODUCTION

**TC6000GN-P1** GPS module provides a high performance and low power GPS solution in a small form factor.

TC6000GN-P1 integrates a complete GPS receiver enabling RF to NMEA solutions that minimize the load on the host processor.

### Features

- GPS all-in-one module
- GPS tracking&navigation sensitivity: -162dBm
- Dedicated GPS processing
- Low load on host CPU
- Standard NMEA 0183 interface
- Precision PPS Output
- Low power consumption (70mW at full operation)
- One single power supply (1.8V) needed
- Miniature 36 pin module (10x9.3x2.0) mm
- Evaluation Boards:
  - TC6000GN Starter Kit for testing on a PC
  - Plug-in Evaluation Module (TC6000GN-EM1 or TC6000GN-EM1-S) board for MSP-EXP430F5438, MSP-EXPF5529 or Stellaris LM3S9B96 EVB

### Applications

- Navigation
  - In-vehicle Navigation equipment
  - Dynamic Navigation
  - Portable ("nomadic") devices
  - Netbooks, tablet PCs and mobile phones
- Timing
  - Precision timing via GPS
- Location based applications
  - GPS Logger
  - GPS Tracker
  - Security devices
  - Camera equipment

## 2 INDEX

1 INTRODUCTION	1
2 INDEX	2
3 DETAILED FEATURES	3
3.1 Block diagram	3
3.2 GPS Features	3
4 TYPICAL APPLICATION BLOCK DIAGRAM	4
5 SYSTEM REQUIREMENTS	4
5.1 Real time clock (RTC)	4
5.2 I/O levels	4
6 GPS CORE	5
6.1 GPS core description	5
6.2 GPS characteristics	5
6.3 GPS Power Management Features	7
6.4 GPS almanac and ephemeris data	7
6.5 Push to Fix	7
6.6 Pulse Per Second (PPS)	8
6.7 Fix Available	8
6.8 GPS Antenna	9
7 ELECTRICAL SPECIFICATION	10
7.1 Absolute Maximum Ratings	10
7.2 Recommended Operating Conditions	10
7.3 GPS input characteristics	10
8 DEVICE PINOUT DIAGRAM	11
9 POWER MANAGEMENT	14
10 RTC CONNECTION	14
11 HARDWARE HOST INTERFACE	15
11.1 GPS UART Interface details	15
12 NMEA DATA	15
13 PHYSICAL DIMENSIONS	16
14 RECOMMENDED PAD LAYOUT	17
15 MATERIAL INFORMATION	17
15.1 Shield Material Information	17
16 RECOMMENDED SOLDERING REFLOW PROFILE	18
17 TAPE INFORMATION	19
18 REEL INFORMATION	20
19 ORDERING INFORMATION	21
20 CUSTOMER SPECIFIC FACTORY OPTIONS & part# assignment	21
21 ENVIRONMENTAL INFORMATION	22
22 MOISTURE SENSITIVITY	23
23 DOCUMENT REVISION HISTORY	23
24 PACKAGING	24
25 RELATED DOCUMENTS	25

### 3 DETAILED FEATURES

#### 3.1 Block diagram

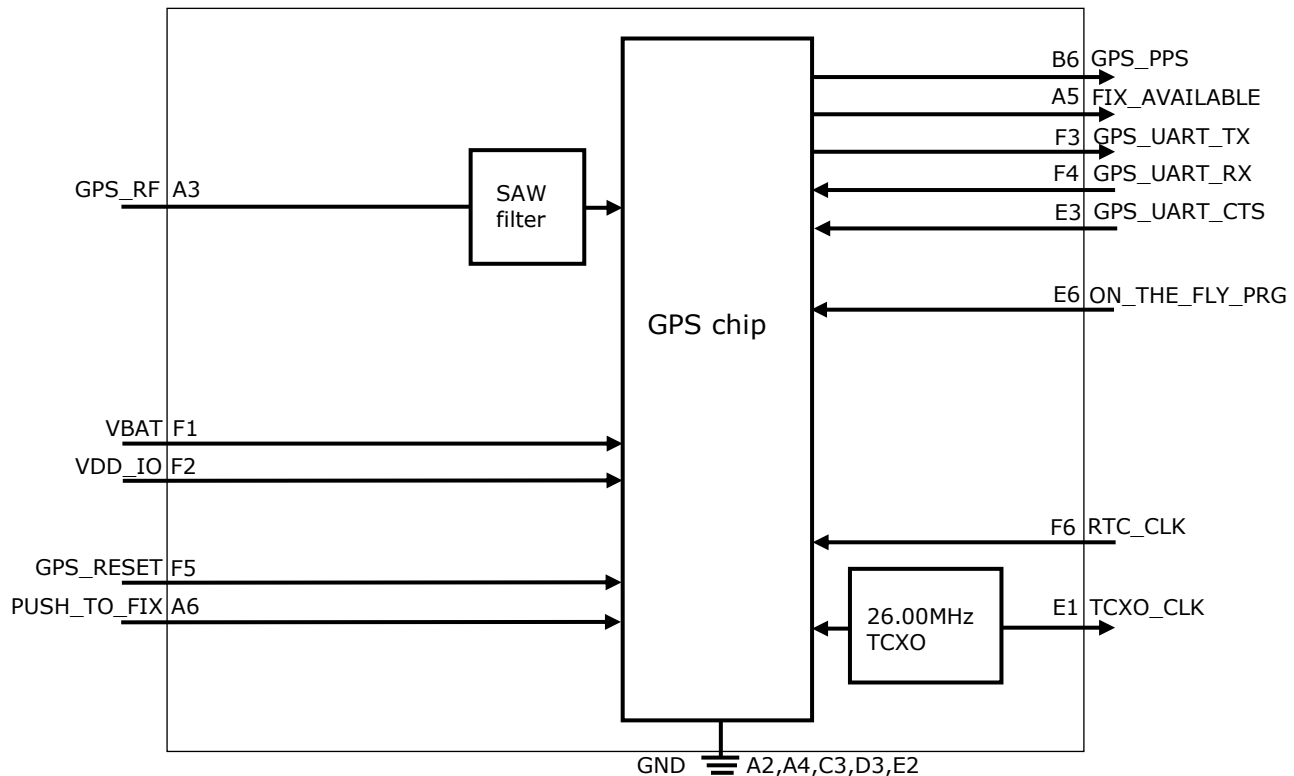

#### 3.2 GPS Features

- Significantly improved TTFF at low signal power levels provides the consumer with a compelling GPS experience
- Improved acquisition performance to process position fixes in deep indoor conditions
- Reduced power consumption through improvements to RF architecture, software techniques, receiver core, and RF noise figure partitioning
- Improved tracking performance and minimized error in multi-path environments through increased IF bandwidth and higher sampling rates in tracking channels
- Standard NMEA output
- Precision 1PPS output
- GPS Fix indication output pin

**4 TYPICAL APPLICATION BLOCK DIAGRAM**

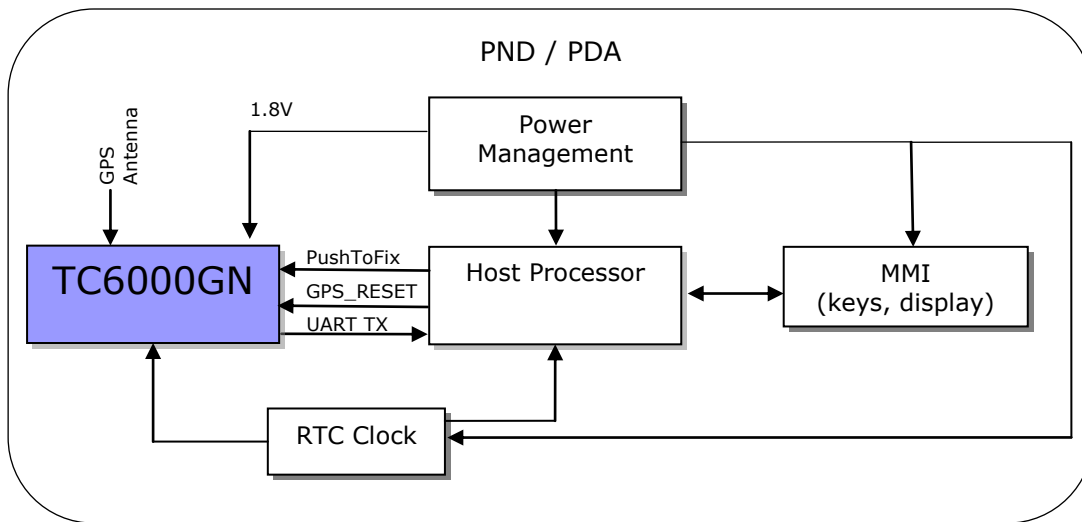

**5 SYSTEM REQUIREMENTS**

TC6000GN-P1 includes a complete GPS engine.

- GPS is fully processed without any host processing requirements
- Standard NMEA message output from the solution to the host
- RTC clock (32.768kHz) should be applied externally.

**5.1 Real time clock (RTC)**

TC6000GN-P1 requires a real time clock input that will provide time information for GPS after an off-time. The clock signal of 32.768kHz is not on-module and has to be fed at pin RTC\_CLK . Additionally, the clock signal is needed for some other chip-internal purposes. See chapter *RTC Connection* for more details

**5.2 I/O levels**

TC6000GN-P1 core and I/O sections work at 1.8V nominal. Absolute Maximum Ratings should not be exceeded

Should the TC6000GN-P1 be interfaced to a host with I/O at higher levels, level shifters should be used.

**No signals are allowed on the device I/Os in the absence of VDD\_IO voltage** because the most I/Os are **not** fail-safe. Not fail-safe means that the pins will draw undefined current from an external voltage applied to the pin, when no I/O power is supplied to the device. Only exception is RTC\_CLK .

## 6 GPS CORE

### 6.1 GPS core description

The TC6000GN-P1 GPS core is a high performance, low power GPS receiver with integrated RF frontend.

Due to high input sensitivity it can work directly with a passive antenna.

The very short TTFF (Time To First Fix) and improved acquisition performance at low signal power levels is achieved through an enhanced receiver core architecture.

The improved RF architecture and software techniques reduce the average power consumption.

Minimized error in multi-path environments is achieved through increased IF bandwidth and higher sampling rates in tracking channels.

TC6000GN-P1 supports APM (adapted power management) schemes to lower the average power of the GPS core to below 27mW.

### 6.2 GPS characteristics

Parameter	Min	Typ	Max	Unit	Note
general					
Frequency		1575.42		MHz	GPS L1 C/A code
Output data frequency	1/60	1	1	1/sec	Configurable
Navigation&tracking sensitivity		-162	-163	dBm	
Acquisition sensitivity		-146	-147	dBm	autonomous
TTFF hotstart			1	sec	All SV's @-130dBm
TTFF hotstart			10	sec	All SV's @-155dBm
TTFF autonomous cold start		34		sec	All SV's @-130dBm
TTFF autonomous cold start		45		sec	All SV's @-142dBm
Number of channels tracking		16			
Number of acquisition channels		40			
Power consumption					
GPS ACTIVE (acquisition)		68	78.6	mA	NMEA frequency = 1/sec
GPS ACTIVE (tracking)		45	53.8	mA	NMEA frequency = 1/sec
GPS ACTIVE (tracking)	15			mA	NMEA frequency=1/sec, -130dBm, APM feature active
GPS shutdown		180		µA	GPS_RESET → GND
GPS deep sleep (RTC running)		80		µA	PUSH_TO_FIX → GND

Accuracy					
Static position error CEP68	-	2	-	m	<b>Normal open sky in Field</b> Horizontal position accuracy using open sky roof-top antenna
Static position error CEP95	-	3	-	m	<b>Normal open sky in Field</b> Horizontal position accuracy using open sky roof-top antenna
Static position error CEP68	-	-	2	m	<b>Simulator feed</b> , IONO and TROPO errors oN at -130 dBm power level
Static position error CEP95	-	-	3	m	<b>Simulator feed</b> , IONO and TROPO errors oN at -130 dBm power level
dynamic position error CEP68	-	-	3	m	<b>Simulator feed</b> , IONO and TROPO errors oN at -130 dBm power level
dynamic position error CEP95	-	-	4	m	<b>Simulator feed</b> , IONO and TROPO errors oN at -130 dBm power level
velocity error CEP68	-	-	0.1	m/s	<b>Simulator feed</b> , IONO and TROPO errors oN at -130 dBm power level
velocity error CEP95	-	-	0.7	m/s	<b>Simulator feed</b> , IONO and TROPO errors oN at -130 dBm power level
Accuracy for timepulse signal					
1PPS pulse duration	-	1	-	msec	
1PPS time jitter	-	-	100	nsec	Pulse rising edge deviation from expected pulse time, measured in a 300 seconds interval with full 3D fix, refer to <a href="http://processors.wiki.ti.com/index.php/CC4000_GPS_for_MCU">http://processors.wiki.ti.com/index.php/CC4000_GPS_for_MCU</a> "TI GPS PPS Timing Application Note"
1PPS rise and fall time	-	-	10	nsec	10%..90%
1PPS output impedance	-	10kΩ//20pF	-	-	
TCXO					
TCXO output frequency	-	26.000	-	MHz	±2.5 ppm
TCXO output impedance	-	1MΩ//5pF	-	-	

ITAR limits					
Operation altitude	-5,000	-	18,288	m	
Operation velocity	-	-	514	m/s	
Operation acceleration	-	-	-	m/s <sup>2</sup>	No limit set

### 6.3 GPS Power Management Features

Power management schemes implemented for any GPS system requires an optimally tuned performance for both accuracy of the position fixes and the average power consumed for best user experience. TC6000GN-P1 architecture achieves both these aspects by providing flexibility and design choices for the system integration based on wide range of use cases and by leveraging on the proven silicon methodologies. Also TC6000GN-P1 provides position, velocity and time (PVT) measurements without any host loading. This, coupled with the optional built-in power management option, reduces the overall system power budget.

Power management features

- APM feature provides overall GPS system power consumption of 27mW in tracking mode under open sky conditions.  
However – same as for any GPS device - the accuracy and stability will be lowered due to reduced activity of the positioning algorithms. Since working parameters of APM are not adjustable, a field test is recommended to confirm usability of power saving algorithm.
- Can provide PVT solution without any load on the host, allowing a reduction in overall system power consumption.
- Position update rates selectable by order option. Max of 1 Hz update rate.

### 6.4 GPS almanac and ephemeris data

For quick re-acquisition of the GPS after off-times, the GPS engine should have access to almanac and ephemeris data. This data is permanently stored inside TC6000GN module. When the GPS is powered-up again, the data will be used to allow a quick re-acquisition, as soon as a coarse time information is available.

### 6.5 Push to Fix

The *Push to Fix* signal is used to initiate a GPS fix session. The signal is defined as active high when starting a GPS fix session. The session can be a cold, warm or host start fix, depending upon the availability and age of the assistance data.

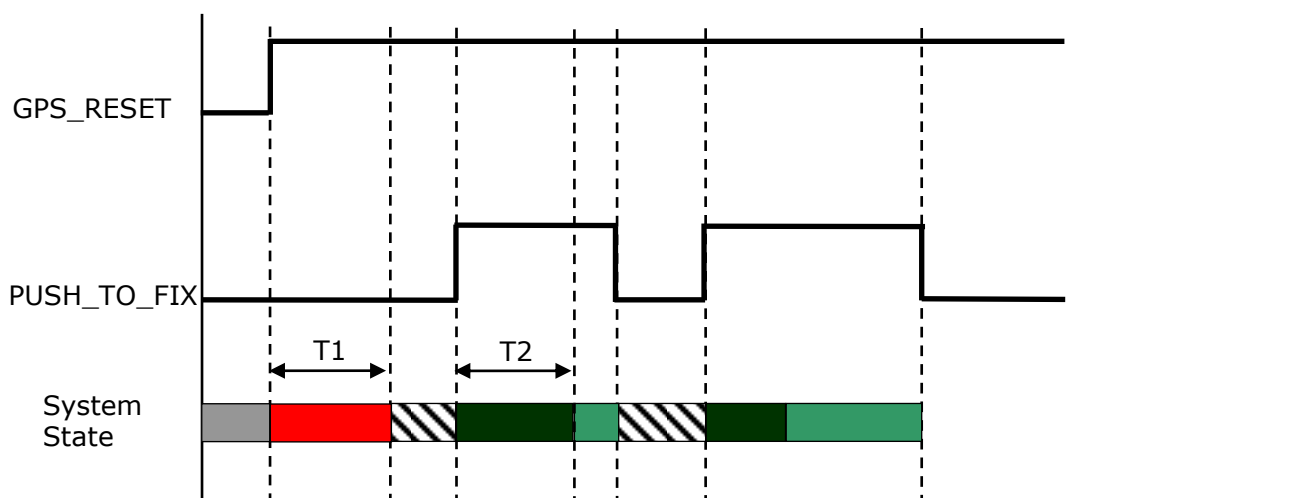

T1 (Boot up) 4.5sec  
 T2 = TTFF

 Reset

 Aquisition

 Sleep

 Boot up

 Tracking

## 6.6 Pulse Per Second (PPS)

TC6000GN provide a so called Pulse Per Second (PPS) for timing purposes. After calculation of a 3D position fix, the PPS signal is accurately aligned to the GPS seconds boundaries. The pulse generated is approximately 1 millisecond in duration and the repetition rate is 1 second.

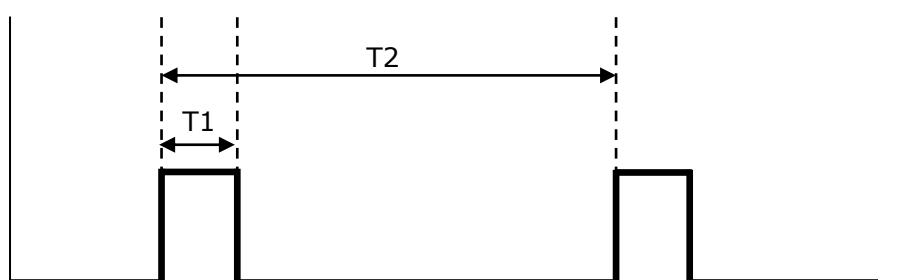

T1 = 1ms    T2 = 1sec

More information about the accuracy of the time pluse, please refer to [http://processors.wiki.ti.com/index.php/CC4000\\_GPS\\_for\\_MCU](http://processors.wiki.ti.com/index.php/CC4000_GPS_for_MCU) "GPS PPS Timing Application Note".

## 6.7 Fix Available

The *FIX AVAILABLE* signal is used to indicate the availability of GPS position information. This is typically used to drive an LED buffer so that the state of the device can be easily indicated. The table below lists the various states.

State	Indication
Initial boot up	low
PUSH_TO_FIX low	low
PUSH_TO_FIX on and aquisition	Toggling (900ms low and 100ms high)
PUSH_TO_FIX on and loss of fix	Toggling (900ms low and 100ms high)
PUSH_TO_FIX on and position fix	continuously high



## 6.8 GPS Antenna

TC6000GN contains all input circuitry needed to connect a passive GPS antenna directly. Depending on the application patch- or chip antennas or combo antennas (combination of GPS and Bluetooth) can be used. However, if there is a long wire between TC6000 GPS RF input and antenna, there should be an LNA (on the antenna side) to compensate for cable losses ("active" antenna). For active antenna configuration, the antenna supply DC must be blocked from the antenna signal line with a inductor **L** of 100nH and a 100pF capacitor **C** as shown in the diagram below.

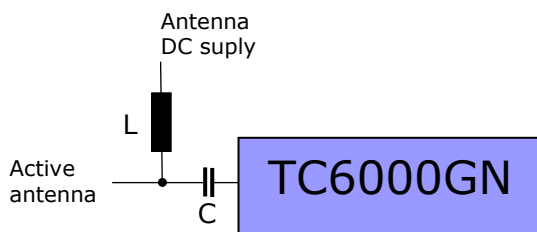

More information about connecting and implementing a GPS antenna to an application PCB, please refer to **GPS Antenna Connection Design Guide**.

## 7 ELECTRICAL SPECIFICATION

### 7.1 Absolute Maximum Ratings

Parameter	Value	Unit
Supply voltage range: VBAT	-0.5 to 2.1	V
Supply voltage range: VDD_IO	-0.5 to 2.1	V
Input voltage to analog pins <sup>1</sup>	-0.5 to 2.1	V
Input voltage to all other pins	-0.5 to (VDD_I/O + 0.5)	V

### 7.2 Recommended Operating Conditions

Parameter	Min	Typ	Max	Unit	Note
VDD	1.7		1.95	V	Power-supply voltage
VDD_IO	1.65		1.92	V	I/O power-supply voltage
High level output voltage V <sub>OH</sub>	0.8 * V <sub>DD</sub>		V <sub>DD</sub>	V	IOUT = 4 mA
Low level output voltage V <sub>OL</sub>	1.45		V <sub>DD</sub>	V	IOUT = 0.4 mA
High-level input voltage V <sub>IH</sub>	0		0.2*V <sub>DD</sub>	V	IOUT = 4 mA
Low-level input voltage V <sub>IL</sub>	0.65x VDD_IO		VDD_IO	V	
Operating temperature	0		0.35x VDD_IO	V	
Storage temperature range	-40		85	°C	Full specified performance
Maximum ripple on VDD			60	mVpp	0 MHz to 0.1 MHz
			50	mVpp	0.1 MHz to 0.5 MHz
			30	mVpp	0.5 MHz to 1.7 MHz
			25	mVpp	1.7 MHz to 2.5 MHz
			15	mVpp	2.5 MHz to 3.3 MHz
			5	mVpp	Greater than 3.3 MHz

### 7.3 GPS input characteristics

Parameter	Min	Typ	Max	Unit	Note
Input impedance		62.7-j3.2		Ω	
Maximum input level	0			dBm	before destruction
Input return loss	-10			dB	

### 8 DEVICE PINOUT DIAGRAM

TOP VIEW

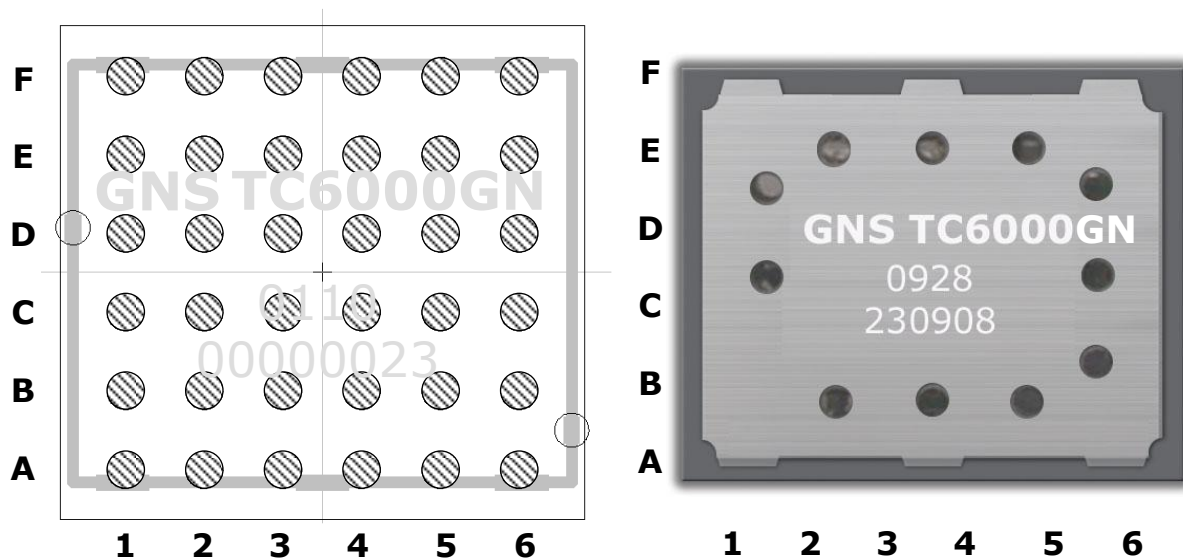

<b>F</b>	VBAT	VDD_IO	GPS_UART_TX	GPS_UART_RX	GPS_RESET	RTC_CLK
<b>E</b>	TCXO_CLK	GND	GPS_UART_CTS	NU12	NU10	ON_THE_FLY_PRG
<b>D</b>	DB_1	DB_2	GND1	NU7	NU8	NU9
<b>C</b>	DB_3	DB_4	GND3	NU13	NU11	NU6
<b>B</b>	NU1	NU2	NU3	NU4	NU5	GPS_PPS
<b>A</b>	NU12	GPS_GND1	GPS_RF	GPS_GND2	FIX_AVAILABLE	PUSH_TO_FIX
	<b>1</b>	<b>2</b>	<b>3</b>	<b>4</b>	<b>5</b>	<b>6</b>

# GPS Module TC6000GN-P1

# Datasheet V026

*confidential information preliminary specification*

NO	NAME	TYPE <sup>1</sup>	DESCRIPTION
<b>Power-Management Signals</b>			
2F	VDD_IO	P	1.8V I/O power supply voltage
1F	VBAT	P	1.8V main power supply voltage
3D	GND1	P	Common Ground
2E	GND2	P	Common Ground
3C	GND3	P	Common Ground
<b>Clock Signals</b>			
1E	TCXO_CLK	O	TCXO_CLK signal output. This Pin delivers the high stable TCXO frequency of 26.000 MHz for external components. Although the output is buffered, do not load this pin below 20kOhms // 10pF(TBD). Leave open if not used.
6F	RTC_CLK	I	Clock input: 32.768 kHz. Input for an external low frequency clock signal. A clock must be provided at this pin to operate the module. See chapter "RTC CONNECTION"
<b>GPS Signals</b>			
3A	GPS_RF	Ana	GPS RF Input, direct connection of passive or active GPS antenna
2A	GPS_GND1	P	GPS RF Ground
4A	GPS_GND2	P	GPS RF Ground
6B	GPS_PPS	O	This output delivers a high-precision pulse-per-second signal that is synchronized to the GPS time reference. The pulse precision is better than $1 \cdot 10^{-7}$ seconds. Although the output is buffered, do not load this pin below 10kOhms // 47pF (TBD). Leave open if not used .
6E	ON_THE_FLY_PRG	I	This input determines operation after reset. Internally pulled up for normal operation. pull low for re- programming firmware or reconfiguring the module. Leave open in normal operation.
6A	PUSH_TO_FIX	I	Input signal to switch between operation and deep sleep mode. internally pulled down. pull high (with less than 4.7kOhm) during operation. pull low (or leave open) to set the module to deep sleep. Internal RTC continues to work in deep sleep.
5A	FIX_AVAILABLE	O	This pin indicates a fix position. Leave open if not used.
5F	GPS_RESET	I	Main Reset for the receiver. Internally weak pulled down. Pull high with less than 100kOhm for operation. pull to GND (or leave open) during power – up.
<b>NOT USED PINS DO NOT CONNECT</b>			
1A	NU12		do not connect or connect to GND
1B	NU1		do not connect or connect to GND
2B	NU2		do not connect or connect to GND
3B	NU3		do not connect or connect to GND
4B	NU4		do not connect or connect to GND
5B	NU5		do not connect or connect to GND
5E	NU10		do not connect or connect to GND
4D	NU7		do not connect or connect to GND
5D	NU8		do not connect or connect to GND
6D	NU9		do not connect or connect to GND
5C	NU11		do not connect or connect to GND
6C	NU6		do not connect or connect to GND
4E	NU12		do not connect or connect to GND
4C	NU13		do not connect or connect to GND
<b>UART</b>			
3F	GPS_UART_TX	O	Main UART TX.
4F	GPS_UART_RX	I	Main UART RX.
3E	GPS_UART_CTS	I	Main UART CTS. CTS not used. Leave open
<b>I2C</b>			
1D	DB_1		must be connected to DB_2
2D	DB_2		must be connected to DB_1
1C	DB_3		must be connected to DB_4
2C	DB_4		must be connected to DB_3

(1) I = INPUT; O = OUTPUT; I/O = BIDIRECTIONAL; P = POWER PIN; ANA = ANALOG PIN.

NOTE: SOME PINS HAVE BEEN REDEFINED FROM STATIC CONNECTION TO NOT USED (NU) IN THIS V0.26 DATASHEET. THE CONNECTIONS ARE NOW MADE INTERNALLY.



---

# GPS Module TC6000GN-P1

# Datasheet V026

*confidential information preliminary specification*

## 9 POWER MANAGEMENT

For quick re-acquisition after power-on, the TC6000GN should stay tied to Vcc during off-times to keep its RTC clock running. The module is put in sleep mode, by holding the PUSH\_TO\_FIX pin low. The pin may be controlled by the host controller or by another power management circuitry, which might be also a simple electromechanical switch.

A static low level on PUSH\_TO\_FIX will keep the TC6000GN-P1 in a deep sleep with power consumption below 100µA.

## 10 RTC CONNECTION

The RTC\_CLK is a free-running clock that needs to be supplied from an external clock source. It is connected to the RTC\_CLK pin on the TC6000GN-P1, and is a digital square wave signal in the range of 0 V to 1.8 V (nominal). The slow clock frequency is 32.768 kHz. RTC\_CLK has multiple functionalities:

- Used to maintain GPS time between sleep intervals
- For clock frequency detection at power-on reset, before TCXO\_CLK is available
- For power up sequencing.

### Digital RTC Requirements

Parameter	Min	Typ	Max	Unit	Note
Input slow clock frequency		32,768		Hz	
Input slow clock accuracy			±200	ppm	Initial temperature + aging
Input transition time			100	ns	t <sub>R</sub> /t <sub>F</sub> : 10% to 90%
Frequency input duty cycle	20%	50%	80%		
V <sub>IH</sub>	0.65x VDD_IO		VDD_IO	V	Slow clock input voltage limits
V <sub>IL</sub>	0		0.35xVDD_IO	V	Slow clock input voltage limits
Load capacitance			10	pF	Capacitance on RTC_CLK pin
Load resistance	1			MΩ	Resistance on RTC_CLK pin

## 11 HARDWARE HOST INTERFACE

TC6000GN-P1 is connected to host system by a UART Interface. Since TC6000GN-P1 is used only to deliver NMEA to the host only a single data line from the module to the host is necessary. The interface requires 1.8V I/O.

The idle state of the lines is positive voltage. To interface a standard RS232 UART (e.g. a PC serial interface), please add an inverting level shifter. To interface processors that have a different interfacing voltage level, level shifters are required.

### 11.1 GPS UART Interface details

- The UART interface is used to send NMEA messages and control data.
- The default baud rate is 9600, other baud rates can be selected by ordering option.
- The maximum baud rate deviation supported is  $\pm 2\%$ .

#### GPS UART Default Settings

Parameter	Value
Baud rate	9600
Data length	8 bits
Stop bit	1
Parity	None

## 12 NMEA DATA

The TC6000GN-P1 provides NMEA 0183 (National Marine Electronics Association) compatible data. The following table shows the available NMEA sentences. All active NMEA sentences are sent at the selected rate.

#### NMEA available sentences

Type	content
\$GPRMC	Recommended Minimum Navigation Information
\$GPGGA	Global Positioning System Fix Data, Time, Position and fix related data for a GPS receiver
\$GPGSV	Satellites in view
\$GPGLL	Geographic Position - Latitude/Longitude
\$GPGSA	GPS DOP and active satellites
\$GPVTG	Track made good and Ground speed

**13 PHYSICAL DIMENSIONS**

TOP VIEW

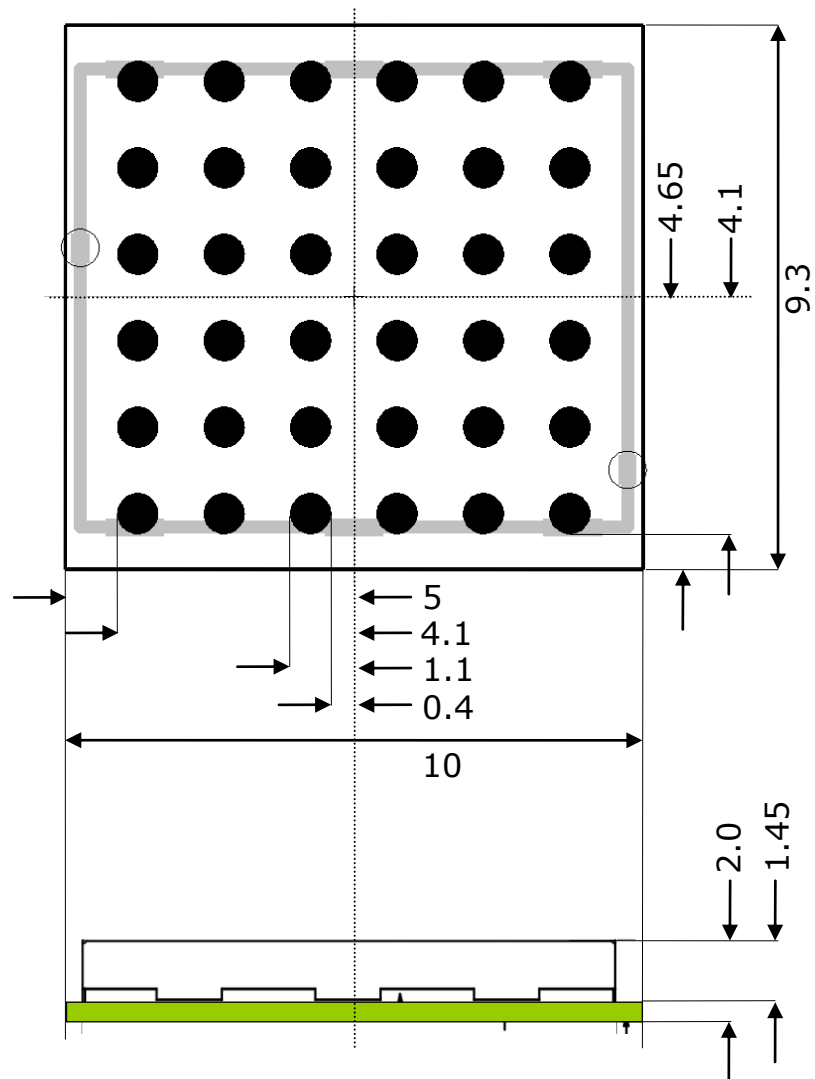

all units in mm  
tolerance :  $\pm 0.1\text{mm}$  for  $< 5\text{mm}$ ,  $\pm 0.2\text{mm}$  for  $\geq 5\text{mm}$



**14 RECOMMENDED PAD LAYOUT**

TOP VIEW

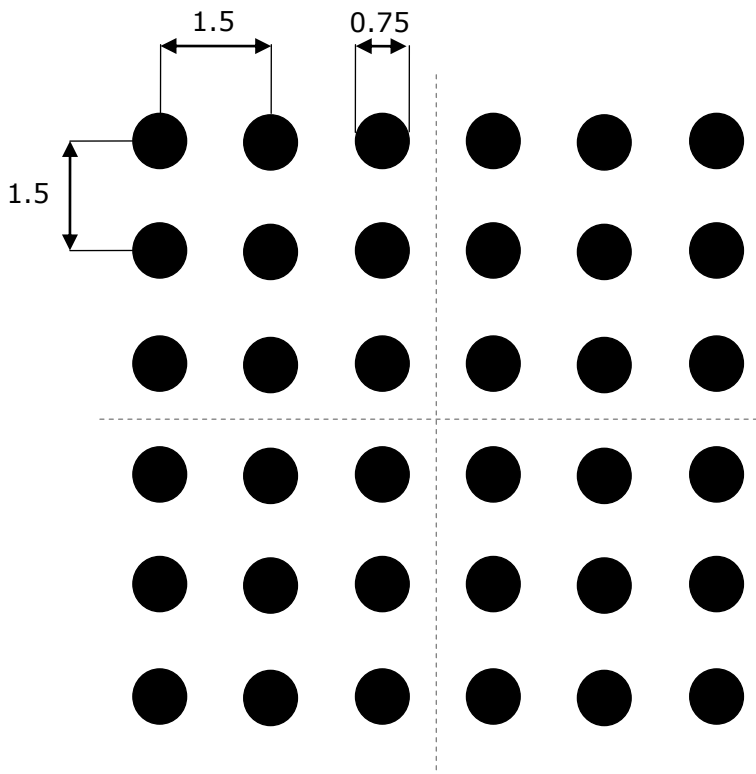

all units in mm

**15 MATERIAL INFORMATION**

Complies to ROHS standard  
 ROHS documentations are available on request  
 Contact surface : gold over nickel

**15.1 Shield Material Information**

"German Silver " , CuNi18Zn27  
 Cu: 53.5..56.5%  
 Ni : 16.5..19.5%  
 Zn : 24..30%  
 thickness :0.2mm

**16 RECOMMENDED SOLDERING REFLOW PROFILE**

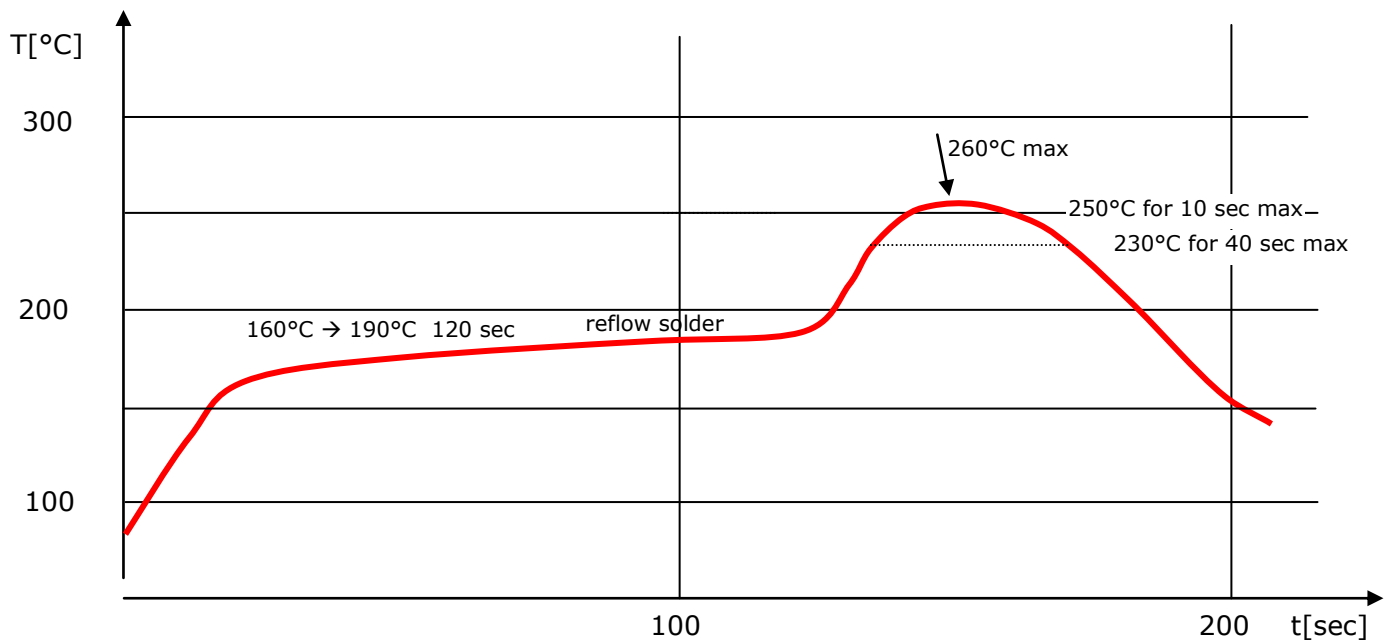

**Notes:**

1. TC6000GN-P1 should be soldered in upright soldering position. In case of head-over soldering, please prevent shielding / TC6000GN-P1 Module from falling down.
2. Do never exceed maximum peak temperature
3. Reflow cycles allowed : 1 time
4. Do not solder with Pb-Sn or other solder containing lead (Pb)
5. This device is not applicable for flow solder processing
6. This device is not applicable for solder iron process

**17 TAPE INFORMATION**

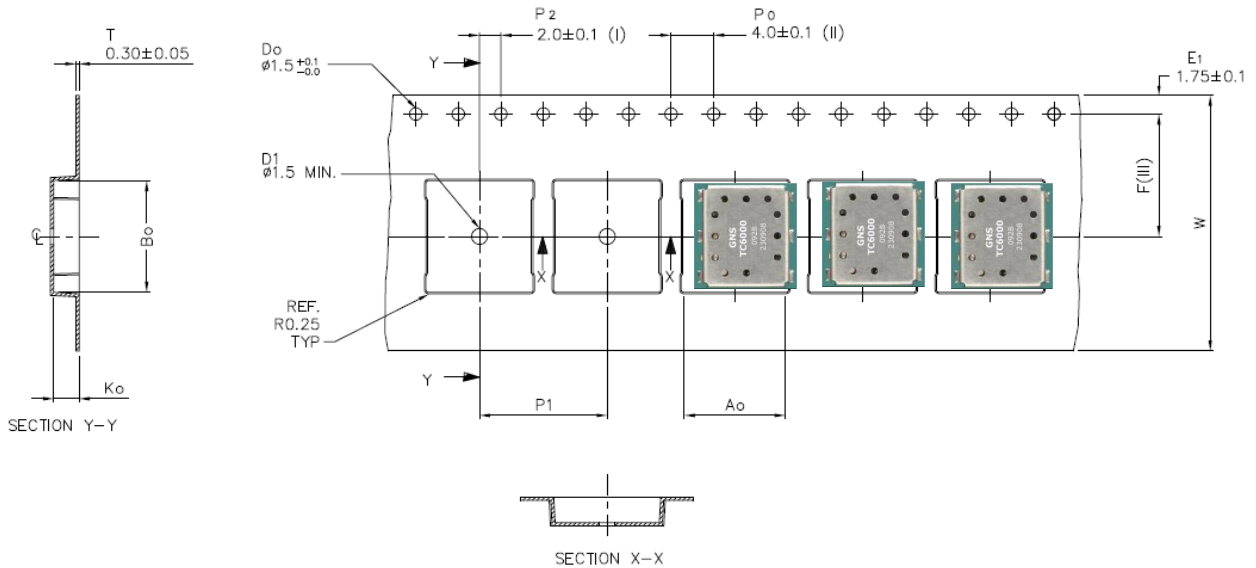

Ao	9.80	+/- 0.1
Bo	10.50	+/- 0.1
Ko	2.40	+/- 0.1
F	11.50	+/- 0.1
P1	12.00	+/- 0.1
W	24.00	+/- 0.3

Forming format : Flatbed  
Estimated max. length : 60 meter/22B3 reel

- (I) Measured from centreline of sprocket hole to centreline of pocket.
- (II) Cumulative tolerance of 10 sprocket holes is  $\pm 0.20$ .
- (III) Measured from centreline of sprocket hole to centreline of pocket.
- (IV) Other material available.

ALL DIMENSIONS IN MILLIMETRES UNLESS OTHERWISE STATED.

**18 REEL INFORMATION**

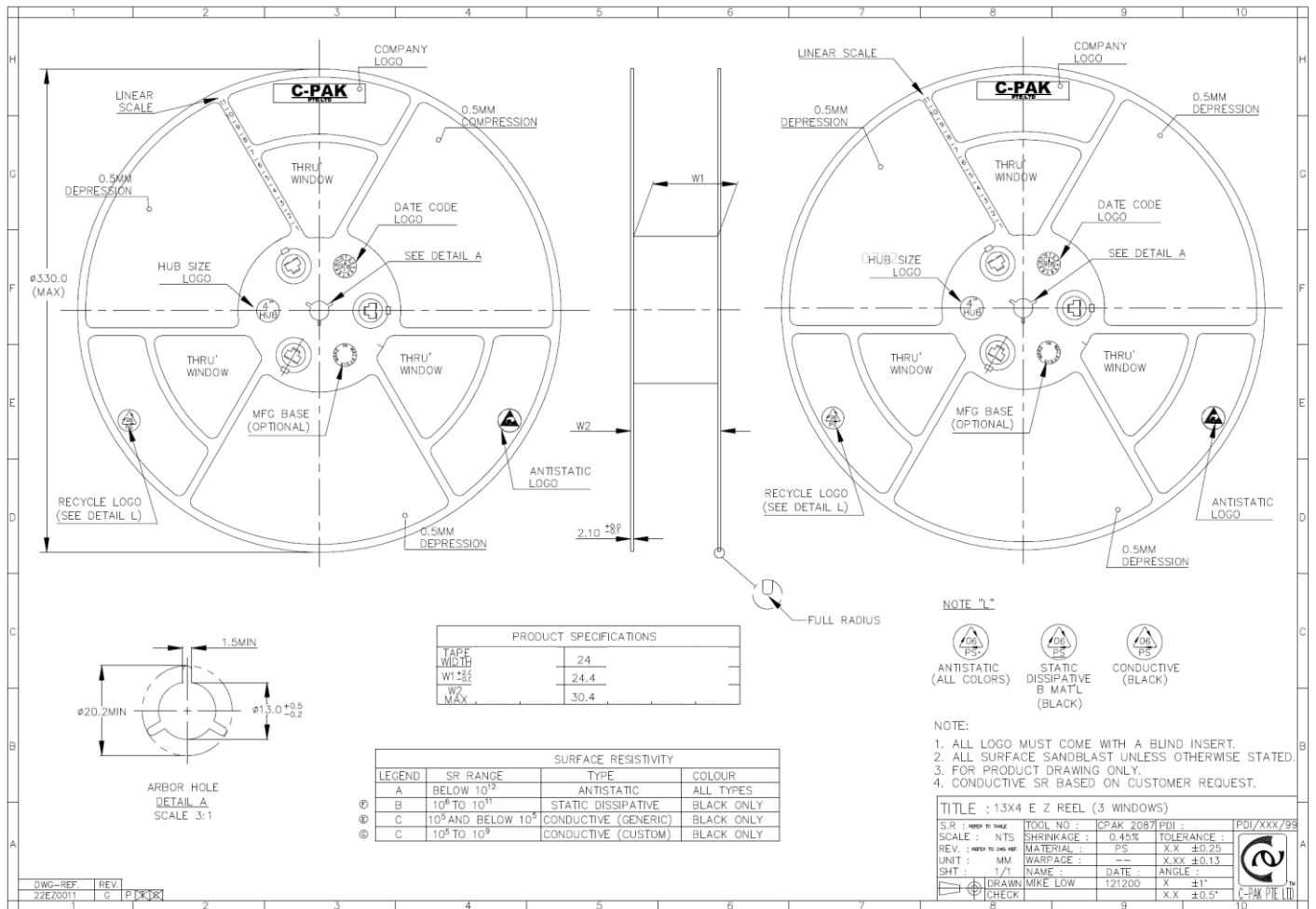

no. of devices : 2000 pcs / reel

## 19 ORDERING INFORMATION

Ordering information			
Type	Part#	Laser marking	Description
TC6000GN-P1	4037735104327	TC6000GN GNS<yy cw> <serial#>	GPS Module with standard options as defined default in chapter 20
TC6000GN-P1 _<options>	40377351xxxxx	TC6000GN GNS<yy cw> <serial#> <last 5 digits of part#>	GPS Module with user defined options. Part# will be assigned individually. See chapter 20 for option details.

## 20 CUSTOMER SPECIFIC FACTORY OPTIONS & part# assignment

Some features of TC6000GN-P1 are factory presets, that should be added to your order information. Customers should define the options with the help of the following options table.

**In case of an order, GNS will assign a new part# , then. This part# is valid for all following orders**

Just replace <options> by the **Short** options given in the table below.

Please use a semicolon ";" for separating the options.

Notes:

**1. You do not need to specify option values that are shown to be default.**

**2. If you do not wish any customized options, the part# will be the above mentioned default: 4037735104327**

Type	Default value	Possible options	Short	note
UART baudrate	9,600 baud	Baud=9600bps Baud=19200bps Baud=38400bps Baud=57600bps Baud=115200bps	9 19 38 57 115	The serial output baud rate.
APM feature	Not active	APM active APM not active	A	APM feature allows the GPS engine to save energy under good reception conditions. Please define A , if you wish to have APM activated.
GPS output rate	1 second (R1)	Rate is x seconds (x=1,2,3,4,5,10,30,60)	R<x>	This option is useful to optimize transfer times by lowering the rate of NMEA messages. Has no influence on the GPS engine activity.

NMEA selection	All 6 types	All combinations possible	RMC GGA GSV GLL GSA VTG	saving unused NMEAs. Please specify all types that should be available
GSV output rate	1	GSV=1 GSV=5	G1 G5	GSV rate can be selected as a <u>multiple</u> of the GPS output rate. This option is used to reduce average data transfer. G5 with a rate of 1 will produce GSV output every 5 seconds
Pulse per second output	active (on)	PPS on PPS off	/P	Activates or deactivates the hardware precision pulse per second. Since active is default, please define /P (no PPS) if PPS should not be available.

For example, if you wish to have a baudrate of 115.2k, and only RMC (once per second) and GSV (every 5 seconds) as output data, please order as follows :

**TC6000GN-P1 115;RMC;GSV;G5**

In another example, Baud Rate is 38400bps, all NMEA sentences except GSV and VTG should be sent at a rate of once per 5 seconds. PPS shall be off:

**TC6000GN-P1 38;RMC;GGA;GLL;GSA;R5;/P**

## 21 ENVIRONMENTAL INFORMATION

This product is free of environmental hazardous substances and complies to 2002/95/EC. (RoHS directive).



## 22 MOISTURE SENSITIVITY

Shelf life	Unlimited
Storage conditions	≤30°C/85%RH
Moisture Sensitivity Level (MSL)	1
Possible prebake recommendations	None

## 23 DOCUMENT REVISION HISTORY

V0.1	Nov 2 2010	P.Skaliks	initial
V0.11	Jan 28 2011	P.Skaliks	Internal Objective - Product name extension P1, GPS features added, packing standard , solder profile, factory options
V0.12	Feb 22 2011	P.Skaliks	Objective - GPS features added, factory options,
V0.13	Apr 13,2011	P.Skaliks	reviewed April 13, flash options added
V0.15		P.Skaliks	Pin definitions reviewed and completed. CTS pindefinitionchanged (not connected) .Document Status changed to preliminary
V0.16		P.Skaliks	Pin definitions reviewed and corrected. Modified ordering instructions to short form, laser marking update
V0.18	Nov 2 2011	P.Skaliks	General review
V0.19	Jan 3 2012	M.Reiff	Related documents update
V0.20	May 18 2012	M.Reiff	Laser Marking confirmed; Operating temperature improved; RF input impedance corrected; Navigation sensitivity added; Additional information added for PUSH_TO_FIX, PPS_OUT and FIX_AVAILABLE signal;
V0.21	July 18 2012	W.Koch	Baud rate corrected to 57600 baud, page 20 "customer specific factory settings".
V0.22	Sep 5 2012	P.Skaliks	Format in table "factory option" and explanation for APM on pg 20
V0.23	Dec 6 2012	M.Reiff	Operating temperature deleted at "absolute maximum ratings"; Feature separator changed; Block diagram added
V0.24	Jun 16 2013	P.Skaliks	Corrected typo :thickness in chpt 13, added tolerance information
V0.25	Aug 9, 2013	P.Skaliks	The ordering information was revised
V0.26	Sep 10 2014	P.Skaliks	APM comment added, Outline information revised, Pin description revised

## 24 PACKAGING

<b>1 reel</b>		
contents	2,000pcs	
GNS part#	2 x 6550000003 1x 6550000011	
dimensions	dia: 330mm thickness:30.4mm	
gross weight	1.195 Kg	with full contents
net weight	0.246 Kg	
<b>2 vacuum bag</b>		
GNS part#	6550000006	
dimensions	400mm x 480mm	
gross weight	1.321 kg	with full contents
net weight	0.068 Kg	
air pressure level	<30mbar	
<b>3 moisture indicator</b>		
GNS part#	6550000008	
dimensions	76mm x 51mm	
weight	0.001 Kg	
<b>4 dry pack</b>		
GNS part#	6550000007	
dimensions	145mm x 140mm	
weight	0.068 Kg	
<b>5 Box for reel</b>		
GNS part#	6550000012	
dimensions	350 mm x 350mm x 47mm	
gross weight	1.5357 kg	with full contents
net weight	0.184 kg	
<b>6 Outer box</b>		
contents	max 7 box for reel	(14,000 pcs TC6000GN-P1 )
dimensions	400mm x 370mm x 360mm	
gross weight	11.6 kg	with full contents
net weight	0.85 kg	



## 25 RELATED DOCUMENTS

Type	description	Available from
<i>TC6000GN-P1 design guide</i>	Contains information about implementation of the module and antenna design	<a href="http://www.forum.gns-gmbh.com">www.forum.gns-gmbh.com</a>
<i>TC6000GN_EM1_UserManual</i>	Hardware manual for the EM1 Evalboard for TI experimenter boards	<a href="http://www.forum.gns-gmbh.com">www.forum.gns-gmbh.com</a>
<i>TC6000GN_EM1_S_UserManual</i>	Hardware manual for the EM1 Evalboard for TI experimenter boards	<a href="http://www.forum.gns-gmbh.com">www.forum.gns-gmbh.com</a>
<i>TC6000GN-P1_StarterKit_User manual</i>	Hardware manual for the GNS Starter Kit	<a href="http://www.forum.gns-gmbh.com">www.forum.gns-gmbh.com</a>
<i>CC4000 firmware update</i>	Wiki that explains update of TC6000GN-EM1 board on a MSP430F5529 experimenter board	<a href="http://processors.wiki.ti.com/index.php/CC4000_Firmware_Update">http://processors.wiki.ti.com/index.php/CC4000_Firmware_Update</a>
<i>MSP430 software for TC6000GN</i>	Wiki that explains the MSP430 software and links to source code downloads	<a href="http://processors.wiki.ti.com/index.php/CC4000_MCU_SW_Description">http://processors.wiki.ti.com/index.php/CC4000_MCU_SW_Description</a>
<i>MSP430 Getting Started Guide</i>	Wiki that explains how to setup and run the MSP430F5529 experimental board using the GNS TC6000GN-EM1 evaluation board	<a href="http://processors.wiki.ti.com/index.php/CC4000_GPS_MSP-EXP430F5529_Getting_Started_Guide">http://processors.wiki.ti.com/index.php/CC4000_GPS_MSP-EXP430F5529_Getting_Started_Guide</a>
<i>GPS Antenna Connection Design Guide</i>	Design Guide to implement an GPS antenna to an application PCB	<a href="http://www.forum.gns-gmbh.com">www.forum.gns-gmbh.com</a>
<i>TC6000GN StarterKit_TestGuide</i>	A guide for testing TC6000GN against other GPS receivers	<a href="http://www.forum.gns-gmbh.com">www.forum.gns-gmbh.com</a>

## X-ON Electronics

Largest Supplier of Electrical and Electronic Components

*Click to view similar products for [GPS Modules category](#):*

*Click to view products by [Global Navigation Systems manufacturer](#):*

Other Similar products are found below :

[A5135-H](#) [EWM-G109H01E](#) [ISM3333-C6.1](#) [S2-106ZN](#) [S2-105V4-Z185K](#) [MIKROE-4150](#) [GPS-11858](#) [4037735104327](#) [RXM-GNSS-TM-T](#)  
[EWM-G108H01E](#) [DD-14239](#) [GPS-10922](#) [GPS-12751](#) [NEO-M8P-2](#) [SIM28ML](#) [RXM-GNSS-GM-T](#) [SIM28](#) [M10578-A3](#) [M10578-A3-U2](#)  
[TEL0132](#) [POL-2G](#) [POL-3G](#) [FT-X-GPS](#) [GPS-13740](#) [PKG300060P](#) [PKG300071](#) [PKG300071P](#) [PKG900000000271T](#) [PKG900000000853P](#)  
[PKG900000000853T](#) [EZ-GPS-G](#) [A2235H](#) [RXM-GNSS-TM-B](#) [RXM-GPS-F4-T](#) [RXM-GPS-FM-B](#) [RXM-GPS-FM-T](#) [RXM-GPS-R4-T](#)  
[A1084-A](#) [A2100-A](#) [A2200-A](#) [A2235-H](#) [A5100-A](#) [28504](#) [L26ADR-S89](#) [L26T-S89](#) [L89-S90](#) [101990655](#) [113990659](#) [GPS-13670](#) [TESEO-](#)  
[LIV3F](#)