

DATA SHEET



PESDxS2UAT series Double ESD protection diodes in SOT23 package

Product data sheet

2004 Feb 18

Double ESD protection diodes in SOT23 package

PESDxS2UAT series

FEATURES

- Unidirectional ESD protection of up to two lines
- Common-cathode configuration
- Max. peak pulse power: $P_{pp} = 330\text{ W}$ at $t_p = 8/20\ \mu\text{s}$
- Low clamping voltage: $V_{(CL)R} = 20\text{ V}$ at $I_{pp} = 18\text{ A}$
- Ultra-low reverse leakage current: $I_{RM} < 700\text{ nA}$
- ESD protection $> 30\text{ kV}$
- IEC 61000-4-2; level 4 (ESD)
- IEC 61000-4-5 (surge); $I_{pp} = 18\text{ A}$ at $t_p = 8/20\ \mu\text{s}$.

APPLICATIONS

- Computers and peripherals
- Communication systems
- Audio and video equipment
- Data lines
- CAN bus protection.

DESCRIPTION

Unidirectional double ESD protection diodes in common cathode configuration in the SOT23 plastic package. Designed to protect up to two transmission or data lines against damage from ElectroStatic Discharge (ESD) and other transients.

MARKING

TYPE NUMBER	MARKING CODE ⁽¹⁾
PESD3V3S2UAT	*7A
PESD5V0S2UAT	*7B
PESD12VS2UAT	*7C
PESD15VS2UAT	*7D
PESD24VS2UAT	*7E

Note

1. * = p : made in Hong Kong.
 * = t : made in Malaysia.
 * = W : made in China.

QUICK REFERENCE DATA

SYMBOL	PARAMETER	VALUE	UNIT
V_{RWM}	reverse stand-off voltage	3.3, 5, 12, 15 and 24	V
C_d	diode capacitance $V_R = 0\text{ V};$ $f = 1\text{ MHz}$	207, 152, 38, 32 and 23	pF
	number of protected lines	2	

PINNING

PIN	DESCRIPTION
1	anode 1
2	anode 2
3	common cathode

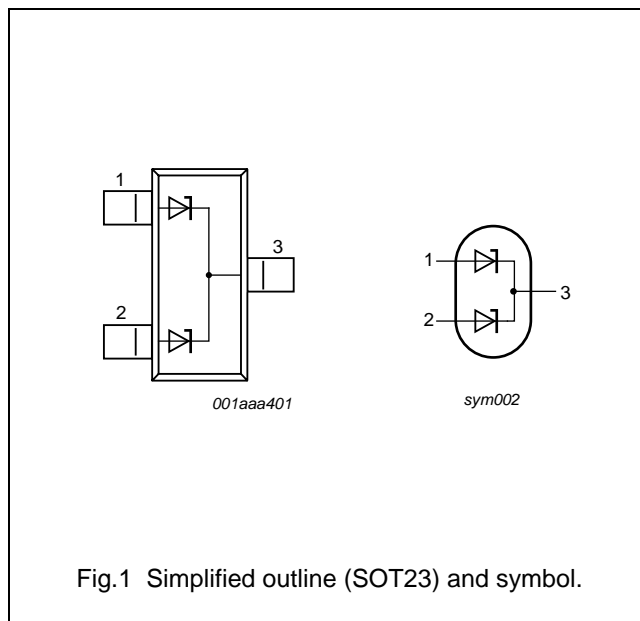

Fig.1 Simplified outline (SOT23) and symbol.

Double ESD protection diodes in SOT23 package

PESDxS2UAT series

ORDERING INFORMATION

TYPE NUMBER	PACKAGE		
	NAME	DESCRIPTION	VERSION
PESD3V3S2UAT	–	plastic surface mounted package; 3 leads	SOT23
PESD5V0S2UAT			
PESD12VS2UAT			
PESD15VS2UAT			
PESD24VS2UAT			

LIMITING VALUES

In accordance with the Absolute Maximum Rating System (IEC 60134).

SYMBOL	PARAMETER	CONDITIONS	MIN.	MAX.	UNIT
P_{pp}	peak pulse power	8/20 μ s pulse; notes 1 and 2	–	330	W
	PESD3V3S2UAT				
	PESD5V0S2UAT				
	PESD12VS2UAT				
	PESD15VS2UAT				
I_{pp}	peak pulse current	8/20 μ s pulse; notes 1 and 2	–	18	A
PESD3V3S2UAT					
PESD5V0S2UAT					
PESD12VS2UAT					
PESD15VS2UAT					
T_j	junction temperature		–	150	$^{\circ}$ C
T_{amb}	operating ambient temperature		–65	+150	$^{\circ}$ C
T_{stg}	storage temperature		–65	+150	$^{\circ}$ C

Notes

1. Non-repetitive current pulse 8/20 μ s exponential decay waveform; see Fig.2.
2. Measured across either pins 1 and 3 or pins 2 and 3.

Double ESD protection diodes in SOT23 package

PESDxS2UAT series

ESD maximum ratings

SYMBOL	PARAMETER	CONDITIONS	VALUE	UNIT
ESD	electrostatic discharge	IEC 61000-4-2 (contact discharge); notes 1 and 2		
		PESD3V3S2UAT	30	kV
		PESD5V0S2UAT	30	kV
		PESD12VS2UAT	30	kV
		PESD15VS2UAT	30	kV
		PESD24VS2UAT	23	kV
		HBM MIL-Std 883		
PESDxS2UAT-series	10	kV		

Notes

1. Device stressed with ten non-repetitive ESD pulses; see Fig.3.
2. Measured from pin 1, 2, 3, 4, 5 or 8 to pin 6 or 7.

ESD standards compliance

ESD STANDARD	CONDITIONS
IEC 61000-4-2; level 4 (ESD); see Fig.3	> 15 kV (air); > 8 kV (contact)
HBM MIL-Std 883; class 3	> 4 kV

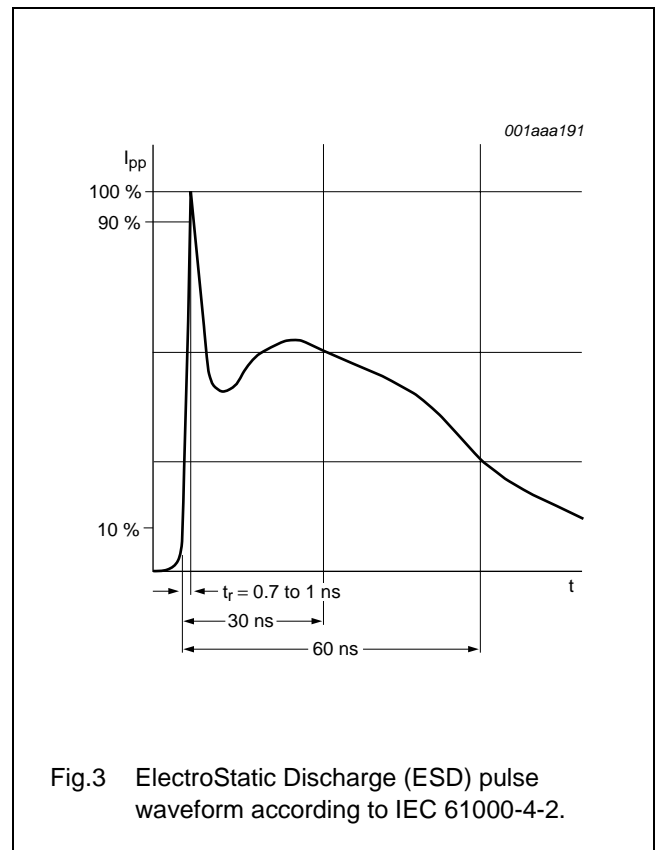
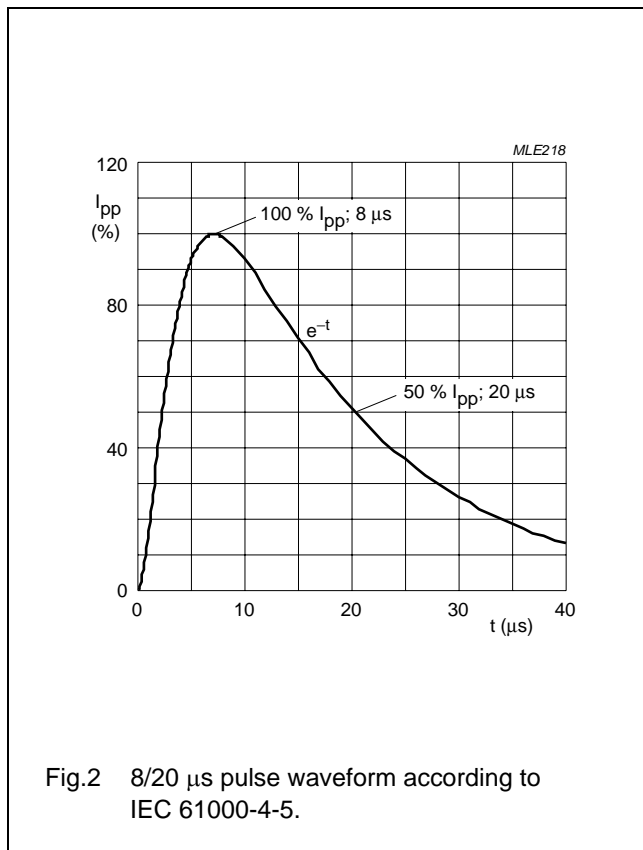

Double ESD protection diodes in SOT23 package

PESDxS2UAT series

ELECTRICAL CHARACTERISTICS

$T_j = 25\text{ }^\circ\text{C}$; unless otherwise specified.

SYMBOL	PARAMETER	CONDITIONS	MIN.	TYP.	MAX.	UNIT
V_{RWM}	reverse stand-off voltage					
	PESD3V3S2UAT		–	–	3.3	V
	PESD5V0S2UAT		–	–	5	V
	PESD12VS2UAT		–	–	12	V
	PESD15VS2UAT		–	–	15	V
	PESD24VS2UAT		–	–	24	V
I_{RM}	reverse leakage current					
	PESD3V3S2UAT	$V_{RWM} = 3.3\text{ V}$	–	0.7	2	μA
	PESD5V0S2UAT	$V_{RWM} = 5\text{ V}$	–	0.1	1	μA
	PESD12VS2UAT	$V_{RWM} = 12\text{ V}$	–	<1	50	nA
	PESD15VS2UAT	$V_{RWM} = 15\text{ V}$	–	<1	50	nA
	PESD24VS2UAT	$V_{RWM} = 24\text{ V}$	–	<1	50	nA
V_{BR}	breakdown voltage	$I_Z = 5\text{ mA}$				
	PESD3V3S2UAT		5.2	5.6	6.0	V
	PESD5V0S2UAT		6.4	6.8	7.2	V
	PESD12VS2UAT		14.7	15.0	15.3	V
	PESD15VS2UAT		17.6	18.0	18.4	V
	PESD24VS2UAT		26.5	27.0	27.5	V
C_d	diode capacitance	$f = 1\text{ MHz}; V_R = 0\text{ V}$				
	PESD3V3S2UAT		–	207	300	pF
	PESD5V0S2UAT		–	152	200	pF
	PESD12VS2UAT		–	38	75	pF
	PESD15VS2UAT		–	32	70	pF
	PESD24VS2UAT		–	23	50	pF
$V_{(CL)R}$	clamping voltage	notes 1 and 2				
	PESD3V3S2UAT	$I_{pp} = 1\text{ A}$	–	–	7	V
		$I_{pp} = 18\text{ A}$	–	–	20	V
	PESD5V0S2UAT	$I_{pp} = 1\text{ A}$	–	–	9	V
		$I_{pp} = 15\text{ A}$	–	–	20	V
	PESD12VS2UAT	$I_{pp} = 1\text{ A}$	–	–	19	V
		$I_{pp} = 5\text{ A}$	–	–	35	V
	PESD15VS2UAT	$I_{pp} = 1\text{ A}$	–	–	23	V
		$I_{pp} = 5\text{ A}$	–	–	40	V
	PESD24VS2UAT	$I_{pp} = 1\text{ A}$	–	–	36	V
		$I_{pp} = 3\text{ A}$	–	–	70	V

Double ESD protection diodes in SOT23 package

PESDxS2UAT series

SYMBOL	PARAMETER	CONDITIONS	MIN.	TYP.	MAX.	UNIT
R _{diff}	differential resistance					
	PESD3V3S2UAT	I _R = 1 mA	–	–	400	Ω
	PESD5V0S2UAT	I _R = 1 mA	–	–	80	Ω
	PESD12VS2UAT	I _R = 1 mA	–	–	200	Ω
	PESD15VS2UAT	I _R = 1 mA	–	–	225	Ω
	PESD24VS2UAT	I _R = 0.5 mA	–	–	300	Ω

Notes

1. Non-repetitive current pulse 8/20 μs exponential decay waveform; see Fig.2.
2. Measured either across pins 1 and 3 or pins 2 and 3.

GRAPHICAL DATA

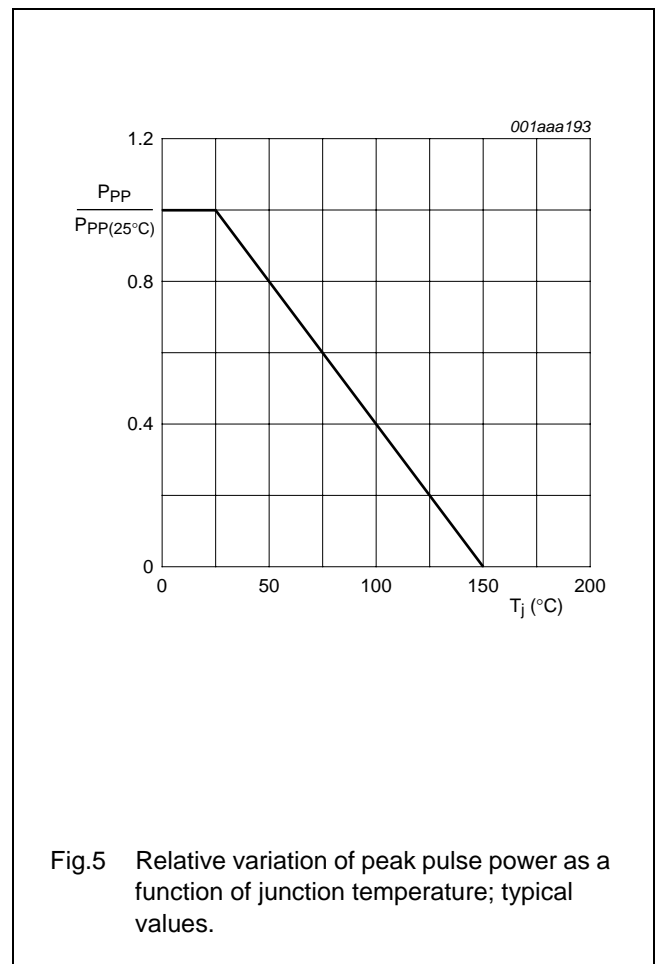
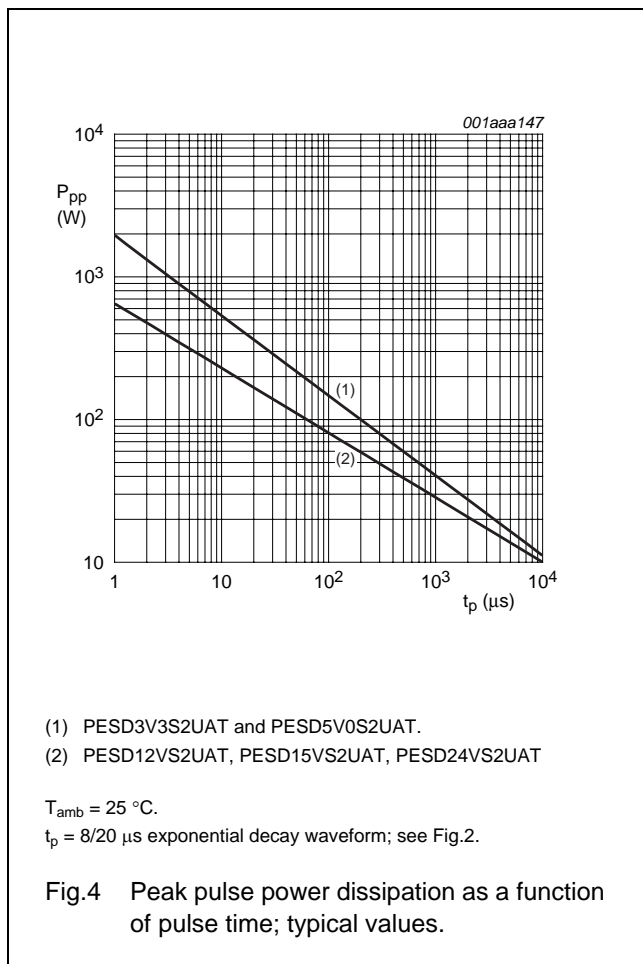

Double ESD protection diodes
in SOT23 package

PESDxS2UAT series

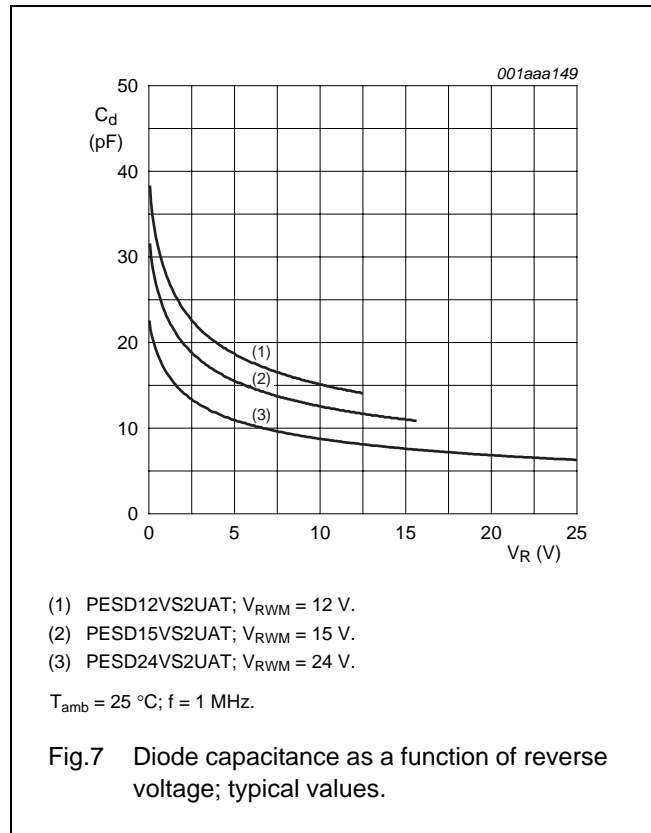
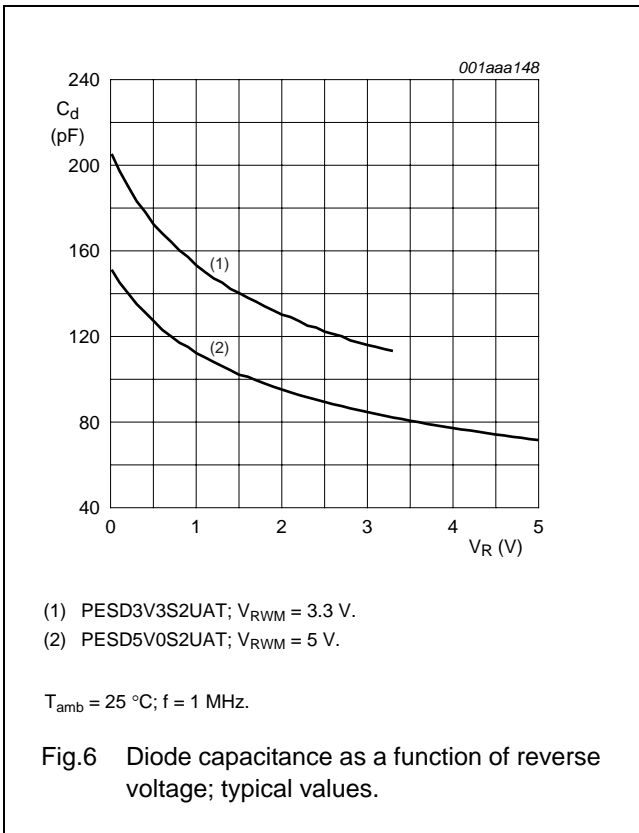

Double ESD protection diodes
in SOT23 package

PESDxS2UAT series

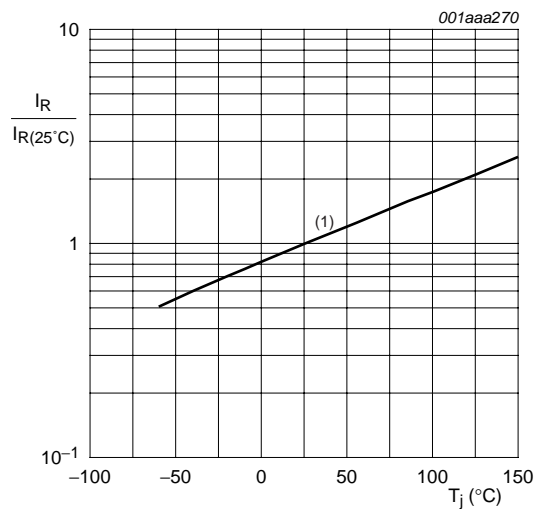

(1) PESD3V3S2UAT; $V_{RWM} = 3.3$ V.
 PESD5V0S2UAT; $V_{RWM} = 5$ V.

I_R is less than 10 nA at 150 °C for:
 PESD12V52UAT; $V_{RWM} = 12$ V.
 PESD15VS2UAT; $V_{RWM} = 15$ V.
 PESD24VS2UAT; $V_{RWM} = 24$ V.

Fig.8 Relative variation of reverse leakage current as a function of junction temperature; typical values.

Double ESD protection diodes in SOT23 package

PESDxS2UAT series

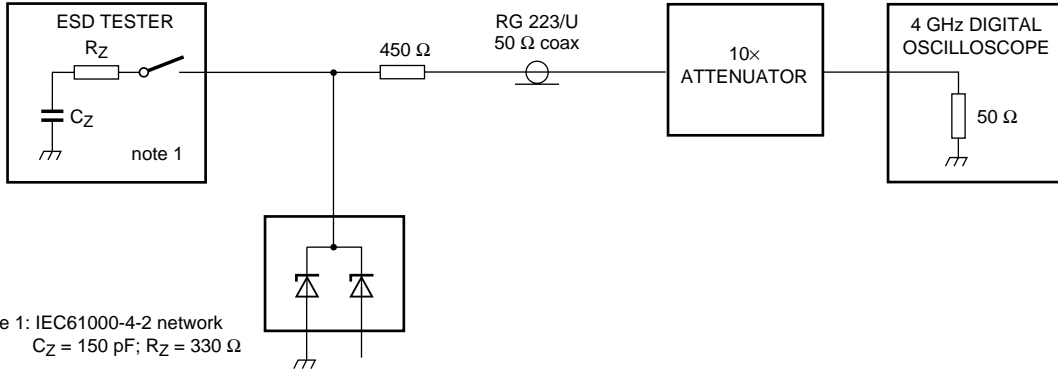

Note 1: IEC61000-4-2 network
 $C_Z = 150 \text{ pF}$; $R_Z = 330 \text{ } \Omega$

D.U.T.: PESDxS2UAT

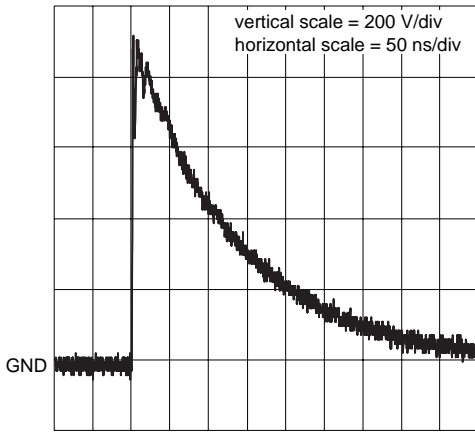

unclamped +1 kV ESD voltage waveform
(IEC61000-4-2 network)

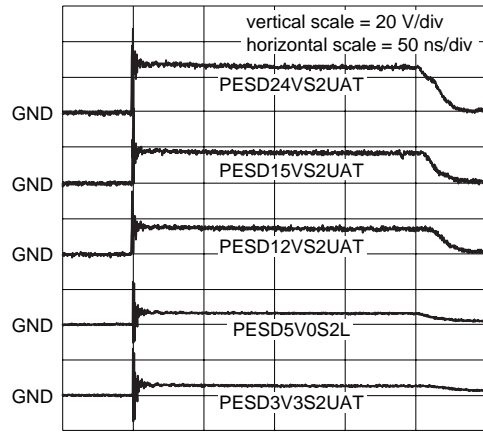

clamped +1 kV ESD voltage waveform
(IEC61000-4-2 network)

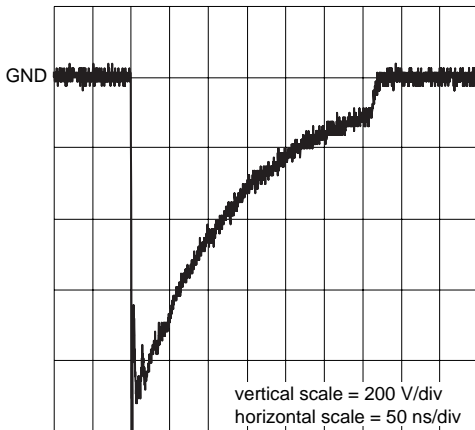

unclamped -1 kV ESD voltage waveform
(IEC61000-4-2 network)

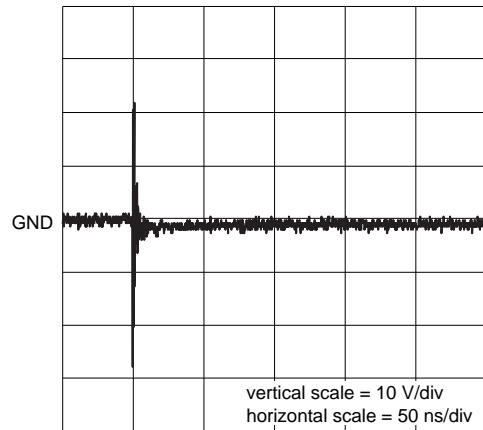

clamped -1 kV ESD voltage waveform
(IEC61000-4-2 network)

001aaa151

Fig.9 ESD clamping test set-up and waveforms.

Double ESD protection diodes in SOT23 package

PESDxS2UAT series

APPLICATION INFORMATION

The PESDxS2UAT series can protect up to two lines against damage caused by unidirectional ElectroStatic Discharge (ESD) and surge pulses. The PESDxS2UAT series can protect lines whose signal polarities are below ground. PESDxS2UAT series provide a surge capability of up to 330 Watts peak pulse power per line for a 8/20 μ s waveform.

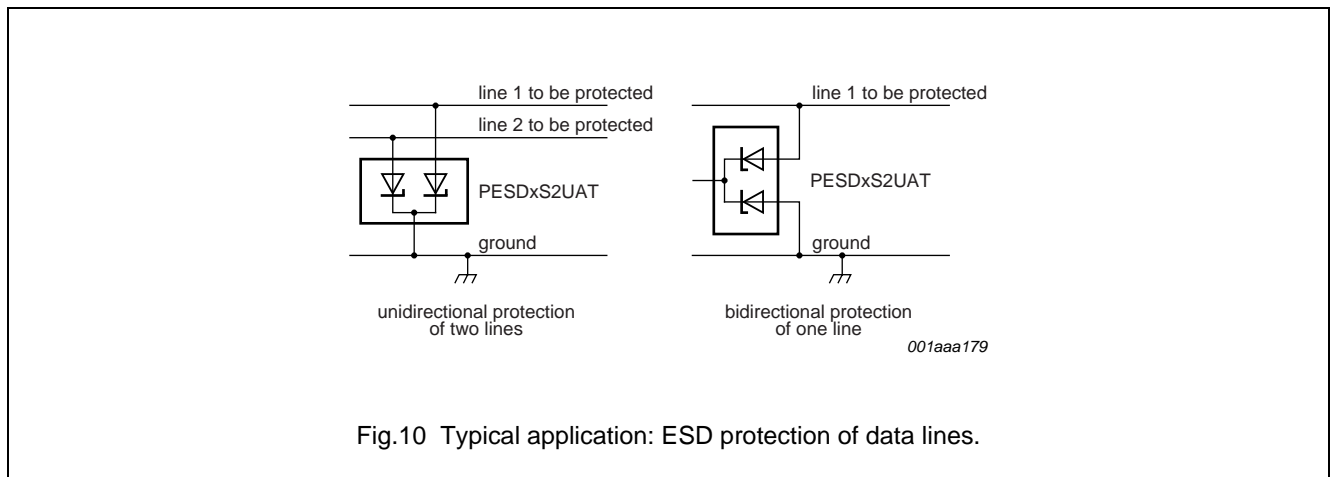

Circuit board layout and protection device placement

Circuit board layout is critical for the suppression of ESD, Electrical Fast Transient (EFT) and surge transients. The following guidelines are recommended:

1. Place the PESDxS2UAT as close as possible to the input terminal or connector.
2. Minimize the path length between the PESDxS2UAT and the protected line.
3. Keep parallel signal paths to a minimum.
4. Avoid running protected conductors in parallel with unprotected conductors.
5. Minimize all printed-circuit board conductive loops including power and ground loops.
6. Minimize the length of transient return paths to ground.
7. Avoid using shared transient return paths to a common ground point.
8. Ground planes should be used whenever possible.
9. Use vias for multi-layer printed-circuit boards.

Double ESD protection diodes in SOT23 package

PESDxS2UAT series

PACKAGE OUTLINE

Plastic surface-mounted package; 3 leads

SOT23

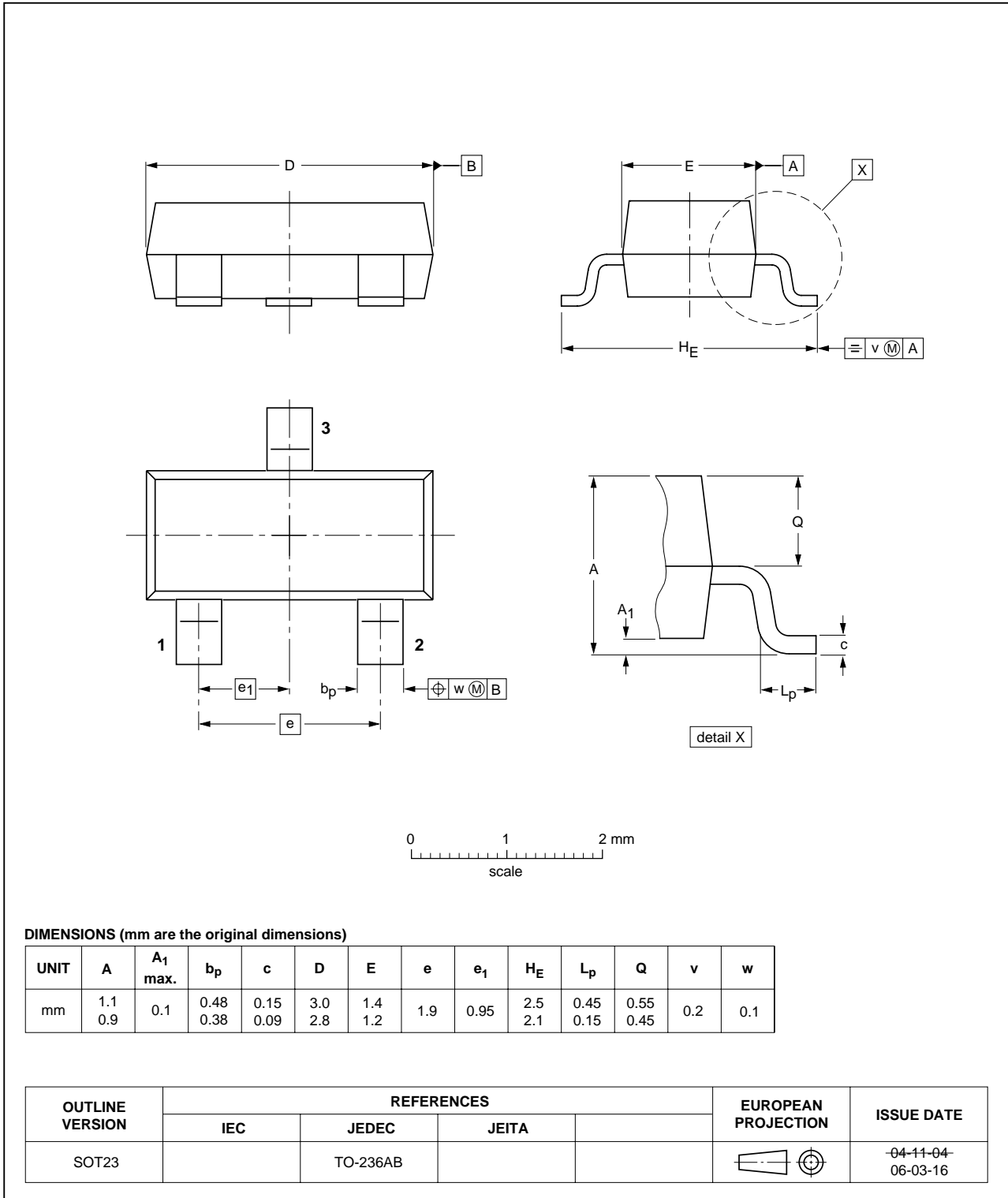

Double ESD protection diodes
in SOT23 package

PESDxS2UAT series

DATA SHEET STATUS

DOCUMENT STATUS ⁽¹⁾	PRODUCT STATUS ⁽²⁾	DEFINITION
Objective data sheet	Development	This document contains data from the objective specification for product development.
Preliminary data sheet	Qualification	This document contains data from the preliminary specification.
Product data sheet	Production	This document contains the product specification.

Notes

1. Please consult the most recently issued document before initiating or completing a design.
2. The product status of device(s) described in this document may have changed since this document was published and may differ in case of multiple devices. The latest product status information is available on the Internet at URL <http://www.nxp.com>.

DISCLAIMERS

General — Information in this document is believed to be accurate and reliable. However, NXP Semiconductors does not give any representations or warranties, expressed or implied, as to the accuracy or completeness of such information and shall have no liability for the consequences of use of such information.

Right to make changes — NXP Semiconductors reserves the right to make changes to information published in this document, including without limitation specifications and product descriptions, at any time and without notice. This document supersedes and replaces all information supplied prior to the publication hereof.

Suitability for use — NXP Semiconductors products are not designed, authorized or warranted to be suitable for use in medical, military, aircraft, space or life support equipment, nor in applications where failure or malfunction of an NXP Semiconductors product can reasonably be expected to result in personal injury, death or severe property or environmental damage. NXP Semiconductors accepts no liability for inclusion and/or use of NXP Semiconductors products in such equipment or applications and therefore such inclusion and/or use is at the customer's own risk.

Applications — Applications that are described herein for any of these products are for illustrative purposes only. NXP Semiconductors makes no representation or warranty that such applications will be suitable for the specified use without further testing or modification.

Limiting values — Stress above one or more limiting values (as defined in the Absolute Maximum Ratings System of IEC 60134) may cause permanent damage to the device. Limiting values are stress ratings only and operation of the device at these or any other conditions

above those given in the Characteristics sections of this document is not implied. Exposure to limiting values for extended periods may affect device reliability.

Terms and conditions of sale — NXP Semiconductors products are sold subject to the general terms and conditions of commercial sale, as published at <http://www.nxp.com/profile/terms>, including those pertaining to warranty, intellectual property rights infringement and limitation of liability, unless explicitly otherwise agreed to in writing by NXP Semiconductors. In case of any inconsistency or conflict between information in this document and such terms and conditions, the latter will prevail.

No offer to sell or license — Nothing in this document may be interpreted or construed as an offer to sell products that is open for acceptance or the grant, conveyance or implication of any license under any copyrights, patents or other industrial or intellectual property rights.

Export control — This document as well as the item(s) described herein may be subject to export control regulations. Export might require a prior authorization from national authorities.

Quick reference data — The Quick reference data is an extract of the product data given in the Limiting values and Characteristics sections of this document, and as such is not complete, exhaustive or legally binding.

NXP Semiconductors

Customer notification

This data sheet was changed to reflect the new company name NXP Semiconductors, including new legal definitions and disclaimers. No changes were made to the technical content, except for package outline drawings which were updated to the latest version.

Contact information

For additional information please visit: <http://www.nxp.com>

For sales offices addresses send e-mail to: salesaddresses@nxp.com

© NXP B.V. 2009

All rights are reserved. Reproduction in whole or in part is prohibited without the prior written consent of the copyright owner.

The information presented in this document does not form part of any quotation or contract, is believed to be accurate and reliable and may be changed without notice. No liability will be accepted by the publisher for any consequence of its use. Publication thereof does not convey nor imply any license under patent- or other industrial or intellectual property rights.

Printed in The Netherlands

R76/01/pp13

Date of release: 2004 Feb 18

Document order number: 9397 750 12247



X-ON Electronics

Largest Supplier of Electrical and Electronic Components

Click to view similar products for [nxp](#) manufacturer:

Other Similar products are found below :

[MC13211R2](#) [PCA9518PW,112](#) [LFSTBEB865X](#) [MC33399PEFR2](#) [PCA9551PW,112](#) [MC34825EPR2](#) [CBTW28DD14AETJ](#) [PCF8583P](#)
[MC68340AB16E](#) [MC8640DTVJ1250HE](#) [EVBCRTOUCH](#) [MC9S08PT16AVLC](#) [MC9S08PT8AVTG](#) [MC9S08SH32CTL](#) [MCF54415CMJ250](#)
[MCIMX6Q-SDB](#) [MCIMX6SX-SDB](#) [74ALVC125BQ,115](#) [74HC4050N](#) [74HC4514N](#) [MK21FN1M0AVLQ12](#) [MKV30F128VFM10](#) [FRDM-](#)
[K66F](#) [FRDM-KW40Z](#) [FRDM-MC-LVBLDC](#) [PESD18VF1BSFYL](#) [PMF63UNEX](#) [PSMN4R0-60YS,115](#) [HEF4028BPN](#) [RAPPID-567XFSW](#)
[MPC565MVR56](#) [MPC574XG-176DS](#) [MPC860PCVR66D4](#) [BT137-600E](#) [BT139X-600.127](#) [BUK7628-100A118](#) [BUK765R0-100E.118](#)
[BZT52H-B9V1.115](#) [BZV85-C3V9.113](#) [BZX79-C47.113](#) [P5020NSE7VNB](#) [S12ZVML12EVBLIN](#) [SCC2692AC1N40](#) [LPC1785FBD208K](#)
[LPC2124FBD64/01](#) [LS1020ASN7KQB](#) [LS1020AXN7HNB](#) [LS1020AXN7KQB](#) [LS1043ASE7PQA](#) [T1023RDB-PC](#)