

### 1.04 Puller

#### 2-arm pattern

The new model for the safe and fast removal of pulleys, wheels, ball bearings, etc. Due to the bending-moment reinforcement on its back face, the energy-saving design of the cross piece means even stronger and safer pulling work. With the newly-developed cantilever hook design, it is possible to use these higher forces without losses over the whole width of the cross piece.

The high-speed adjustment feature supports the energy-saving and fast operation. The spindle possesses an interchangeable tip, meaning that a ball tip may also be employed if necessary.

Spindle may be exchanged for hydraulic pressure spindle (see table).

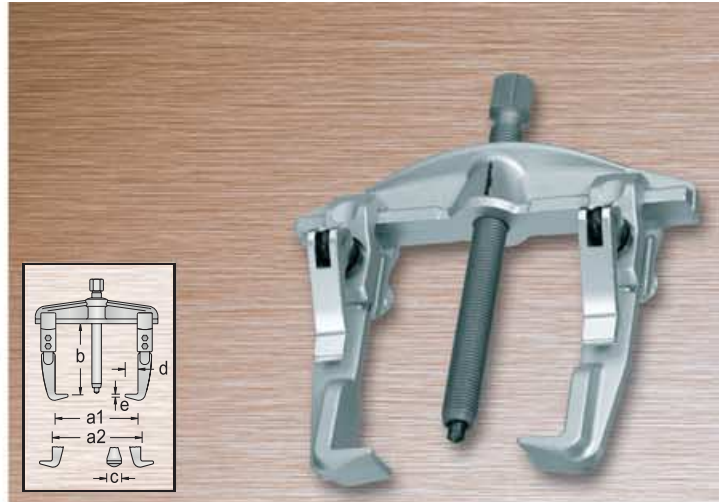

| Code    | No.     | a <sub>1</sub> | a <sub>2 min</sub> | a <sub>2 max</sub> | b   | Hydraulic spindle | mm | c  | d  | e   | max. t |     |
|---------|---------|----------------|--------------------|--------------------|-----|-------------------|----|----|----|-----|--------|-----|
| 1307703 | 1.04/1A | 130            | 70                 | 170                | 100 | M 14x1,5 x 140    | 17 | 22 | 15 | 3,0 | 3,0    | 1.2 |
| 1307827 | 1.04/2A | 200            | 110                | 260                | 150 | G 1/2 x 210       | 22 | 30 | 25 | 4,5 | 5,0    | 3.3 |
| 1307940 | 1.04/3A | 350            | 150                | 420                | 200 | G 3/4 x 280       | 27 | 36 | 33 | 6,0 | 7,5    | 9.9 |

### 1.06 Universal puller

#### 2-arm pattern

The reliable model for the fast and safe removal of pulleys, wheels, ball bearings, etc.

Strong drop forged design.

Reversible hooks permit use as an internal or external puller.

Available extras are replaceable hooks for various clamping reaches.

Spindle may be exchanged for hydraulic pressure spindle (see table).

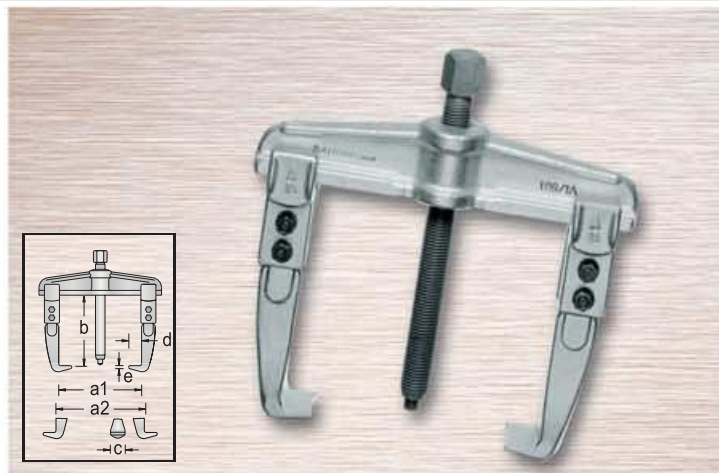

| Code    | No.     | a <sub>1</sub> | a <sub>2 min</sub> | a <sub>2 max</sub> | b   | Hydraulic spindle | mm        | c  | d  | e   | max. t |      |      |
|---------|---------|----------------|--------------------|--------------------|-----|-------------------|-----------|----|----|-----|--------|------|------|
| 8000230 | 1.06/1  | 90             | 60                 | 140                | 100 | M 14x1,5 x 140    | 17        | 22 | 12 | 3,0 | 3,0    | 1.1  |      |
| 8000310 | 1.06/1A | 130            | 70                 | 180                | 100 | M 14x1,5 x 140    | 17        | 22 | 12 | 3,0 | 3,0    | 1.3  |      |
| 8000580 | 1.06/2  | 160            | 80                 | 220                | 150 | G 1/2 x 210       | 1.06/HSP1 | 22 | 30 | 18  | 3,5    | 5,0  | 3.2  |
| 8000660 | 1.06/2A | 200            | 90                 | 260                | 150 | G 1/2 x 210       | 1.06/HSP1 | 22 | 30 | 18  | 3,5    | 5,0  | 3.6  |
| 8000740 | 1.06/3  | 250            | 125                | 330                | 200 | G 3/4 x 280       | 1.06/HSP2 | 27 | 36 | 28  | 6,5    | 7,5  | 7.8  |
| 8000820 | 1.06/3A | 350            | 125                | 420                | 200 | G 3/4 x 280       | 1.06/HSP2 | 27 | 36 | 28  | 6,5    | 7,5  | 9.2  |
| 8000900 | 1.06/4  | 520            | 185                | 600                | 200 | G 1 x 310         | 1.06/HSP3 | 36 | 36 | 28  | 6,5    | 10,0 | 15.2 |
| 8112970 | 1.06/5  | 640            | 230                | 715                | 225 | G 1 x 310         | 1.06/HSP3 | 36 | 50 | 33  | 10,0   | 18,0 | 23.5 |

### 1.06 Universal puller

#### 2-arm pattern, with extended hooks

As universal puller No. 1.06/1 to 1.06/4, but with extended pulling hooks.

Spindle may be exchanged for hydraulic pressure spindle (see table).

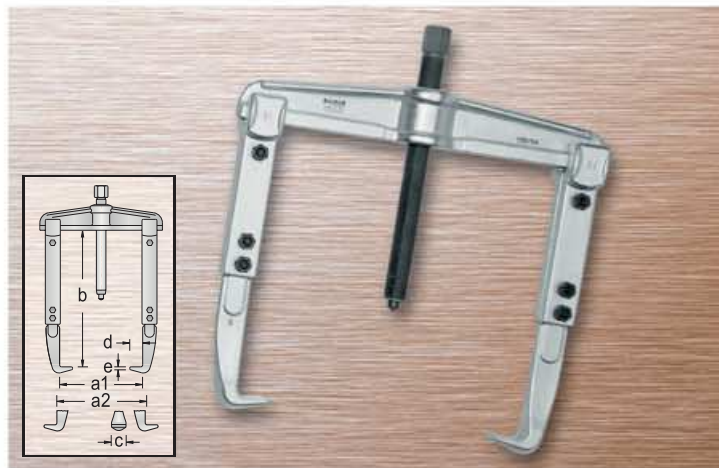

| Code    | No.       | a <sub>1</sub> | a <sub>2 min</sub> | a <sub>2 max</sub> | b   | Hydraulic spindle | mm        | c  | d  | e   | max. t |      |      |
|---------|-----------|----------------|--------------------|--------------------|-----|-------------------|-----------|----|----|-----|--------|------|------|
| 8108350 | 1.06/1-2  | 90             | 60                 | 140                | 200 | M 14x1,5 x 140    | 17        | 22 | 12 | 3,0 | 3,0    | 1.5  |      |
| 8108430 | 1.06/1A-2 | 130            | 70                 | 180                | 200 | M 14x1,5 x 140    | 17        | 22 | 12 | 3,0 | 3,0    | 1.8  |      |
| 8108510 | 1.06/2-3  | 160            | 80                 | 220                | 300 | G 1/2 x 210       | 1.06/HSP1 | 22 | 30 | 18  | 3,5    | 5,0  | 4.4  |
| 8108780 | 1.06/2A-3 | 200            | 90                 | 260                | 300 | G 1/2 x 210       | 1.06/HSP1 | 22 | 30 | 18  | 3,5    | 5,0  | 4.8  |
| 8001200 | 1.06/3-3  | 250            | 125                | 330                | 300 | G 3/4 x 280       | 1.06/HSP2 | 27 | 36 | 28  | 6,5    | 7,5  | 9.1  |
| 8108860 | 1.06/3A-3 | 350            | 125                | 420                | 300 | G 3/4 x 280       | 1.06/HSP2 | 27 | 36 | 28  | 6,5    | 7,5  | 10.5 |
| 8108940 | 1.06/4-3  | 520            | 185                | 600                | 300 | G 1 x 310         | 1.06/HSP3 | 36 | 36 | 28  | 6,5    | 10,0 | 16.5 |
| 8109080 | 1.06/3-4  | 250            | 125                | 330                | 400 | G 3/4 x 280       | 1.06/HSP2 | 27 | 36 | 28  | 6,5    | 7,5  | 10.4 |
| 8109160 | 1.06/3A-4 | 350            | 125                | 420                | 400 | G 3/4 x 280       | 1.06/HSP2 | 27 | 36 | 28  | 6,5    | 7,5  | 11.8 |
| 8109240 | 1.06/4-4  | 520            | 185                | 600                | 400 | G 1 x 310         | 1.06/HSP3 | 36 | 36 | 28  | 6,5    | 10,0 | 17.8 |
| 8109320 | 1.06/3-5  | 250            | 125                | 330                | 500 | G 3/4 x 280       | 1.06/HSP2 | 27 | 36 | 28  | 6,5    | 7,5  | 11.6 |
| 8112380 | 1.06/3A-5 | 350            | 125                | 420                | 500 | G 3/4 x 280       | 1.06/HSP2 | 27 | 36 | 28  | 6,5    | 7,5  | 13.0 |
| 8112460 | 1.06/4-5  | 520            | 185                | 600                | 500 | G 1 x 310         | 1.06/HSP3 | 36 | 36 | 28  | 6,5    | 10,0 | 19.0 |

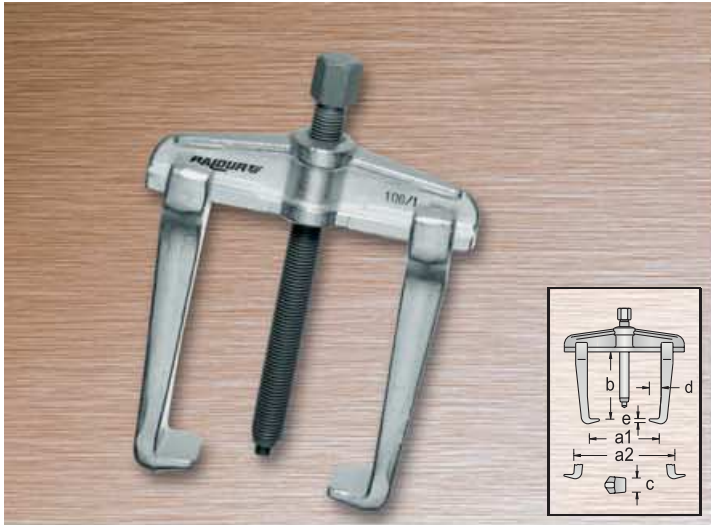

**1.06 Universal puller**  
2-arm pattern, with rigid hooks

Design as universal puller No. 1.06/1 to 1.06/4, but with rigid pulling hooks. For greater ease in setting the clamping spread. The hooks clamp automatically when under tension. The hooks may be reversed to convert the puller from an external one to an internal one. Spindle may be exchanged for hydraulic pressure spindle (see table).

| Code    | No.      | a <sub>1</sub> | a <sub>2</sub> min | a <sub>2</sub> max | b   | Hydraulic spindle | mm        | c  | d  | e   | max. t |      |      |
|---------|----------|----------------|--------------------|--------------------|-----|-------------------|-----------|----|----|-----|--------|------|------|
| 8001470 | 1.06/11  | 100            | 50                 | 140                | 100 | M 14x1,5 x 140    | 17        | 22 | 15 | 4,0 | 3,0    | 0.8  |      |
| 8001040 | 1.06/1A1 | 140            | 60                 | 180                | 100 | M 14x1,5 x 140    | 17        | 22 | 15 | 4,0 | 3,0    | 1.2  |      |
| 8001550 | 1.06/21  | 170            | 80                 | 220                | 150 | G 1/2 x 210       | 1.06/HSP1 | 22 | 30 | 24  | 3,5    | 5,0  | 2.7  |
| 8001120 | 1.06/2A1 | 210            | 90                 | 260                | 150 | G 1/2 x 210       | 1.06/HSP1 | 22 | 30 | 24  | 3,5    | 5,0  | 3.1  |
| 8001630 | 1.06/31  | 250            | 125                | 340                | 200 | G 3/4 x 280       | 1.06/HSP2 | 27 | 36 | 32  | 5,0    | 7,5  | 6.6  |
| 8001390 | 1.06/3A1 | 340            | 125                | 430                | 200 | G 3/4 x 280       | 1.06/HSP2 | 27 | 36 | 32  | 5,0    | 7,5  | 8.0  |
| 8109400 | 1.06/41  | 520            | 185                | 610                | 200 | G 1 x 310         | 1.06/HSP3 | 36 | 36 | 32  | 5,0    | 10,0 | 14.0 |

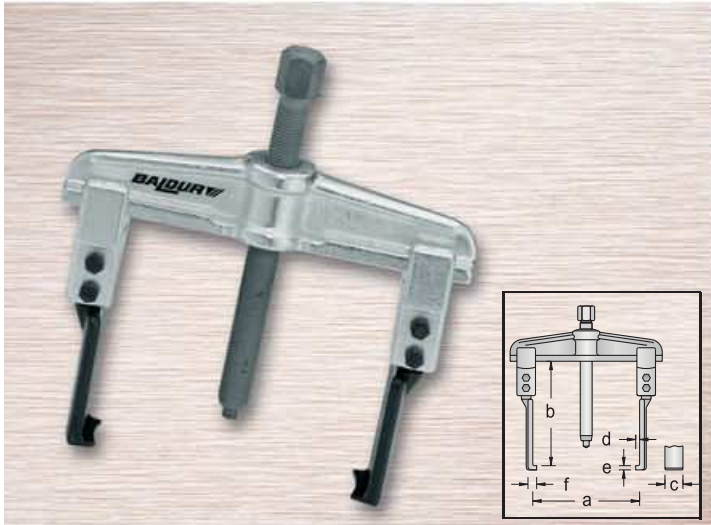

**1.06 Universal puller**  
2-arm pattern, with slim hooks

The feet of the hooks are very slim and particularly suitable for barely-accessible places.

| Code    | No.      | a   | b   | Hydraulic spindle | mm | c  | d | e   | f  | max. t |     |
|---------|----------|-----|-----|-------------------|----|----|---|-----|----|--------|-----|
| 8113510 | 1.06/S1  | 100 | 100 | M 14x1,5 x 140    | 17 | 27 | 6 | 3,6 | 13 | 2,5    | 1.0 |
| 8113780 | 1.06/S1A | 140 | 100 | M 14x1,5 x 140    | 17 | 27 | 6 | 3,6 | 13 | 2,5    | 1.2 |
| 8114830 | 1.06/S2  | 160 | 150 | G 1/2 x 210       | 22 | 40 | 8 | 5,0 | 17 | 5,0    | 3.0 |
| 8114910 | 1.06/S2A | 200 | 150 | G 1/2 x 210       | 22 | 40 | 8 | 5,0 | 17 | 5,0    | 3.2 |

9

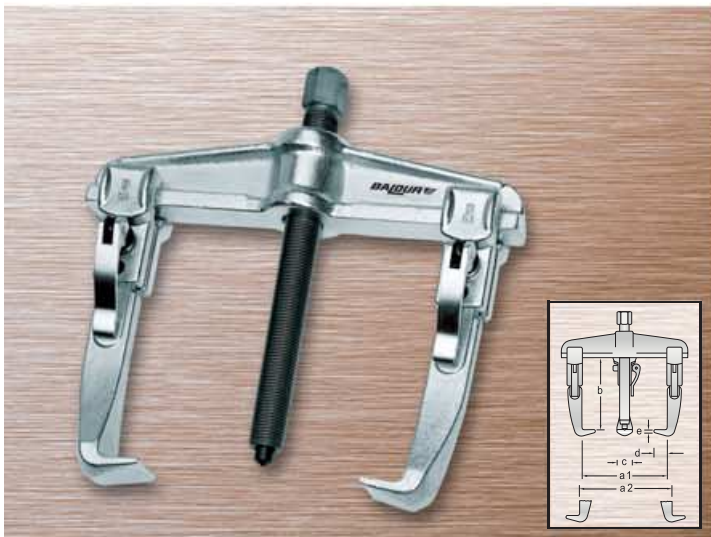

**1.06 Fast clamping puller**  
2-arm pattern, with fast-clamp adjustment

The tried and tested model for the safe and fast removal of pulleys, wheels, ball bearings, etc. Strong drop forged pattern. By reversing the hooks, this tool may be used as an internal or external puller. Exchangeable hooks for several clamping reaches available as accessories. With the innovative high-speed clamps, fast and uncomplicated setting-up and readjustment is child's play. Spindle may be exchanged for hydraulic pressure spindle (see table).

| Code    | No.       | a <sub>1</sub> | a <sub>2</sub> min | a <sub>2</sub> max | b   | Hydraulic spindle | mm        | c  | d  | e   | max. t |     |     |
|---------|-----------|----------------|--------------------|--------------------|-----|-------------------|-----------|----|----|-----|--------|-----|-----|
| 1213830 | 1.06/1-E  | 90             | 60                 | 140                | 100 | M 14x1,5 x 140    | 17        | 22 | 12 | 3,0 | 3,0    | 1.1 |     |
| 1215140 | 1.06/1A-E | 130            | 70                 | 180                | 100 | M 14x1,5 x 140    | 17        | 22 | 12 | 3,0 | 3,0    | 1.3 |     |
| 1216570 | 1.06/2-E  | 160            | 80                 | 220                | 150 | G 1/2 x 210       | 1.06/HSP1 | 22 | 30 | 18  | 3,5    | 5,0 | 3.2 |
| 1217720 | 1.06/2A-E | 200            | 90                 | 260                | 150 | G 1/2 x 210       | 1.06/HSP1 | 22 | 30 | 18  | 3,5    | 5,0 | 3.6 |
| 1218980 | 1.06/3-E  | 250            | 125                | 330                | 200 | G 3/4 x 280       | 1.06/HSP2 | 27 | 36 | 28  | 6,5    | 7,5 | 7.8 |
| 1220160 | 1.06/3A-E | 350            | 125                | 420                | 200 | G 3/4 x 280       | 1.06/HSP2 | 27 | 36 | 28  | 6,5    | 7,5 | 9.2 |

### 1.06 HSP Universal puller

#### hydraulic, 2-arm pattern

The tried and tested model for the safe and fast removal of pulleys, wheels, ball bearings, etc. Drop forged pattern. By reversing the hooks, this tool may be used as an internal or external puller. With the hydraulic spindle, a controlled and safe pulling action is possible at all times.

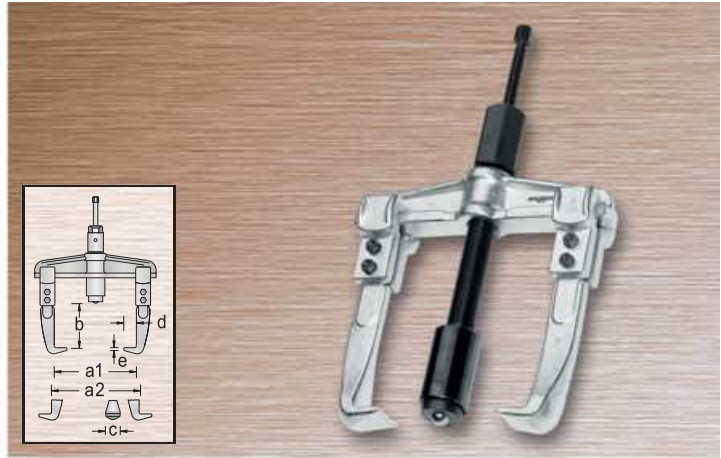

| Code    | No.          | a <sub>1</sub> | a <sub>2</sub> | b   | Spindle   | c  | d  | e    | max. t |      |
|---------|--------------|----------------|----------------|-----|-----------|----|----|------|--------|------|
| 8000150 | 1.06/2-HSP1  | 160            | 220            | 75  | 1.06/HSP1 | 30 | 18 | 3,5  | 5,0    | 3.6  |
| 8002870 | 1.06/2A-HSP1 | 200            | 260            | 75  | 1.06/HSP1 | 30 | 18 | 3,5  | 5,0    | 4.0  |
| 8003170 | 1.06/3-HSP2  | 250            | 330            | 125 | 1.06/HSP2 | 36 | 28 | 6,5  | 7,5    | 8.2  |
| 8003920 | 1.06/3A-HSP2 | 350            | 420            | 125 | 1.06/HSP2 | 36 | 28 | 6,5  | 7,5    | 9.6  |
| 8004060 | 1.06/4-HSP3  | 520            | 600            | 90  | 1.06/HSP3 | 36 | 28 | 6,5  | 10,0   | 16.5 |
| 8004730 | 1.06/5-HSP3  | 640            | 715            | 110 | 1.06/HSP3 | 50 | 33 | 10,0 | 18,0   | 24.5 |

### 1.06 HSP Universal puller

#### hydraulic, 2-arm pattern, with extended hooks

For the highest requirements. With the hydraulic spindle, a controlled and safe pulling action is possible at all times.

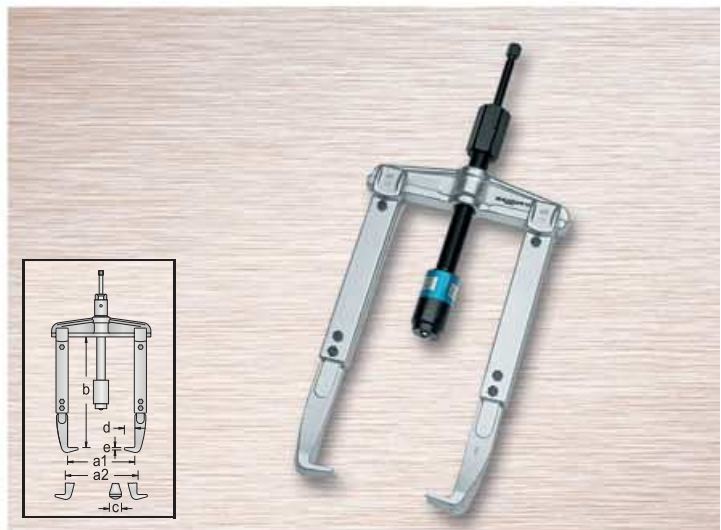

| Code    | No.            | a <sub>1</sub> | a <sub>2</sub> | b   | Spindle   | c  | d  | e   | max. t |      |
|---------|----------------|----------------|----------------|-----|-----------|----|----|-----|--------|------|
| 8005700 | 1.06/2-3-HSP1  | 160            | 220            | 225 | 1.06/HSP1 | 30 | 18 | 3,5 | 5,0    | 4.8  |
| 8005890 | 1.06/2A-3-HSP1 | 200            | 260            | 225 | 1.06/HSP1 | 30 | 18 | 3,5 | 5,0    | 5.2  |
| 8005970 | 1.06/3-3-HSP2  | 250            | 330            | 225 | 1.06/HSP2 | 36 | 28 | 6,5 | 7,5    | 9.5  |
| 8006940 | 1.06/3A-3-HSP2 | 350            | 420            | 225 | 1.06/HSP2 | 36 | 28 | 6,5 | 7,5    | 11.4 |
| 8007240 | 1.06/4-3-HSP3  | 520            | 600            | 190 | 1.06/HSP3 | 36 | 28 | 6,5 | 10,0   | 18.4 |
| 8007670 | 1.06/3-4-HSP2  | 250            | 330            | 325 | 1.06/HSP2 | 36 | 28 | 6,5 | 7,5    | 10.4 |
| 8007750 | 1.06/3A-4-HSP2 | 350            | 420            | 325 | 1.06/HSP2 | 36 | 28 | 6,5 | 7,5    | 11.3 |
| 8007830 | 1.06/4-4-HSP3  | 520            | 600            | 290 | 1.06/HSP3 | 36 | 28 | 6,5 | 10,0   | 19.4 |
| 8007910 | 1.06/3-5-HSP2  | 250            | 330            | 425 | 1.06/HSP2 | 36 | 28 | 6,5 | 7,5    | 12.4 |
| 8008480 | 1.06/3A-5-HSP2 | 350            | 420            | 425 | 1.06/HSP2 | 36 | 28 | 6,5 | 7,5    | 13.4 |
| 8008560 | 1.06/4-5-HSP3  | 520            | 600            | 390 | 1.06/HSP3 | 36 | 28 | 6,5 | 10,0   | 20.4 |

### 1.06 HSP Universal puller

#### hydraulic, 2-arm pattern, with rigid hooks

With pulling hooks in one piece, drop forged pattern. By reversing the hooks, this tool may be used as an internal or external puller. With the hydraulic spindle, a controlled and safe pulling action is possible at all times.

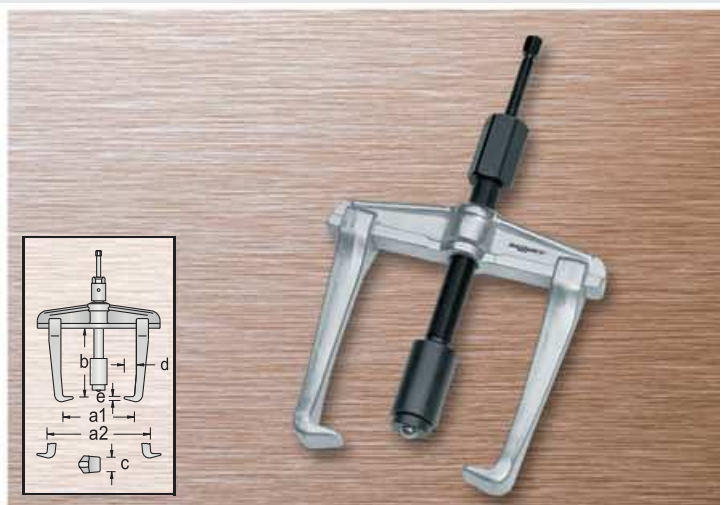

| Code    | No.           | a <sub>1</sub> | a <sub>2</sub> | b   | Spindle   | c  | d  | e   | max. t |      |
|---------|---------------|----------------|----------------|-----|-----------|----|----|-----|--------|------|
| 8008640 | 1.06/21-HSP1  | 170            | 220            | 75  | 1.06/HSP1 | 30 | 24 | 3,5 | 5,0    | 3.7  |
| 8008720 | 1.06/2A1-HSP1 | 210            | 260            | 75  | 1.06/HSP1 | 30 | 24 | 3,5 | 5,0    | 3.8  |
| 8008800 | 1.06/31-HSP2  | 250            | 340            | 115 | 1.06/HSP2 | 36 | 32 | 5,0 | 7,5    | 7.0  |
| 8008990 | 1.06/3A1-HSP2 | 340            | 430            | 115 | 1.06/HSP2 | 36 | 32 | 5,0 | 7,5    | 8.8  |
| 8009370 | 1.06/41-HSP3  | 520            | 610            | 80  | 1.06/HSP3 | 36 | 32 | 5,0 | 10,0   | 14.8 |

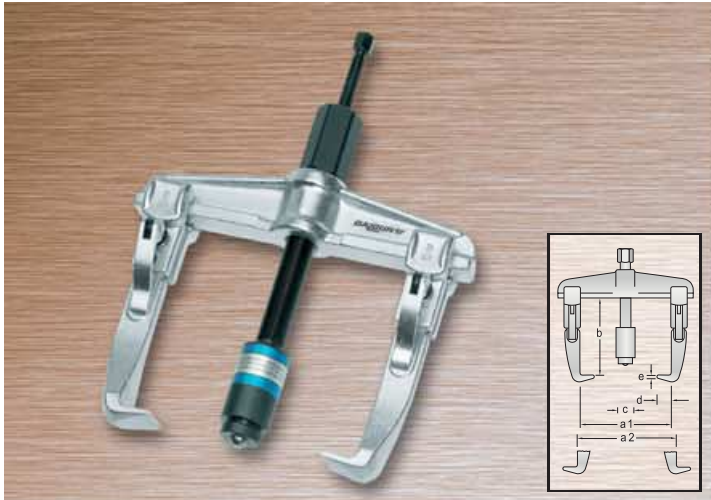

### 1.06 HSP Fast clamping puller hydraulic, 2-arm pattern

With the hydraulic spindle, a controlled and safe pulling action is possible at all times. With the innovative high-speed clamps, fast and uncomplicated setting-up and readjustment is child's play.

| Code    | No.            | a <sub>1</sub> | a <sub>2</sub> | b   | Spindle   | c  | d  | e   | max. t |     |
|---------|----------------|----------------|----------------|-----|-----------|----|----|-----|--------|-----|
| 1221256 | 1.06/2-E-HSP1  | 160            | 220            | 75  | 1.06/HSP1 | 30 | 18 | 3,5 | 5,0    | 3.7 |
| 1221450 | 1.06/2A-E-HSP1 | 200            | 260            | 75  | 1.06/HSP1 | 30 | 18 | 3,5 | 5,0    | 4.1 |
| 1221639 | 1.06/3-E-HSP2  | 250            | 330            | 125 | 1.06/HSP2 | 36 | 28 | 6,5 | 7,5    | 7.6 |
| 1221760 | 1.06/3A-E-HSP2 | 350            | 420            | 125 | 1.06/HSP2 | 36 | 28 | 6,5 | 7,5    | 8.8 |



### 1.06 HSP Hydraulic pressure spindle

These grease-hydraulic pressure spindle has been designed for controlled and safe pulling work, and is set up for a pressure of up to 15 t.

Preparation for use:

1. Before using, check whether the pressure spindle is screwed far enough out of the cap, so that the pressure pad is in the initial position in the hydraulic cylinder.
2. Unscrew the cap from the spindle body.  
For this purpose, first slacken off the grub screw.
3. Screw the spindle body from beneath into the cross piece of the puller until the body protrudes approx. 60 mm from the cross piece.
4. Screw the cap onto the spindle body until the stop, and then fix it in position by turning in the grub screw.  
Use and operation: e.g. HSP3
5. Place the puller into position and pre-tension the spindle body using a size 41 mm wrench.
6. Screw the pressure spindle size 17 mm into the cap.  
The hydraulic effect will come into use. The stroke of the pressure pad in the hydraulic cylinder is max. 12 mm.  
The workpiece that has been loosened by the hydraulic force may be pulled off completely by turning the spindle body with the cap size 41 mm.
7. Following its use, the pressure spindle (size 17 mm) is turned back into its initial position and the pressure pad pushed into the hydraulic cylinder.

| Code    | No.       | a    | b   | c   | d   | e  | f  | Stroke mm | max. t |     |
|---------|-----------|------|-----|-----|-----|----|----|-----------|--------|-----|
| 8116100 | 1.06/HSP1 | 1/2" | 55  | 135 | 350 | 12 | 32 | 12        | 12     | 1.1 |
| 8116290 | 1.06/HSP2 | 3/4" | 80  | 205 | 420 | 12 | 36 | 12        | 12     | 1.8 |
| 8116370 | 1.06/HSP3 | 1"   | 125 | 165 | 465 | 17 | 41 | 12        | 15     | 3.6 |

9



### 1.06 Extension for pullers DGBM

The one-piece drop forged extensions enable the clamping reach to be extended indefinitely. The extensions may be used together with all hooks of the 1.06 range. (Delivery in pairs).

DGBM = German Federal Utility Patent

| Code    | No.       |                         | b   |     |
|---------|-----------|-------------------------|-----|-----|
| 8036500 | 1.06/V100 | for 1.06/A and 1.06/100 | 100 | 0.4 |
| 8036690 | 1.06/V150 | for 1.06/B and 1.06/150 | 150 | 1.2 |
| 8036770 | 1.06/V200 | for 1.06/C and 1.06/200 | 200 | 2.6 |

### 1.06 Pulling hooks

set of 2 pieces

Pulling hooks (1 pair including clamping parts), in standard and special lengths.

| Code    | No.        | †††           | b   | c  | d  | e    | ☺☺  |
|---------|------------|---------------|-----|----|----|------|-----|
| 8035020 | 1.06/A     | 1.06/1 /1A    | 100 | 22 | 12 | 3,0  | 0,6 |
| 8035100 | 1.06/B     | 1.06/2 /2A    | 150 | 30 | 18 | 3,5  | 1,6 |
| 8035290 | 1.06/C     | 1.06/3 /3A /4 | 200 | 36 | 28 | 6,5  | 3,5 |
| 8114400 | 1.06/D     | 1.06/5        | 225 | 50 | 35 | 11,0 | 3,5 |
| 8035370 | 1.06/AV    | 1.06/1 /1A    | 200 | 22 | 12 | 3,0  | 1,1 |
| 8035450 | 1.06/BV    | 1.06/2 /2A    | 300 | 30 | 18 | 3,5  | 2,8 |
| 8035530 | 1.06/CV    | 1.06/3 /3A /4 | 300 | 36 | 28 | 6,5  | 5,0 |
| 8035610 | 1.06/DV    | 1.06/3 /3A /4 | 400 | 36 | 28 | 6,5  | 6,3 |
| 8035880 | 1.06/EV    | 1.06/3 /3A /4 | 500 | 36 | 28 | 6,5  | 7,5 |
| 8112700 | 1.06/D-300 | 1.06/5        | 320 | 50 | 35 | 11,0 | 5,7 |
| 8112890 | 1.06/D-400 | 1.06/5        | 420 | 50 | 35 | 11,0 | 6,4 |
| 8113860 | 1.06/D-500 | 1.06/5        | 520 | 50 | 35 | 11,0 | 8,4 |

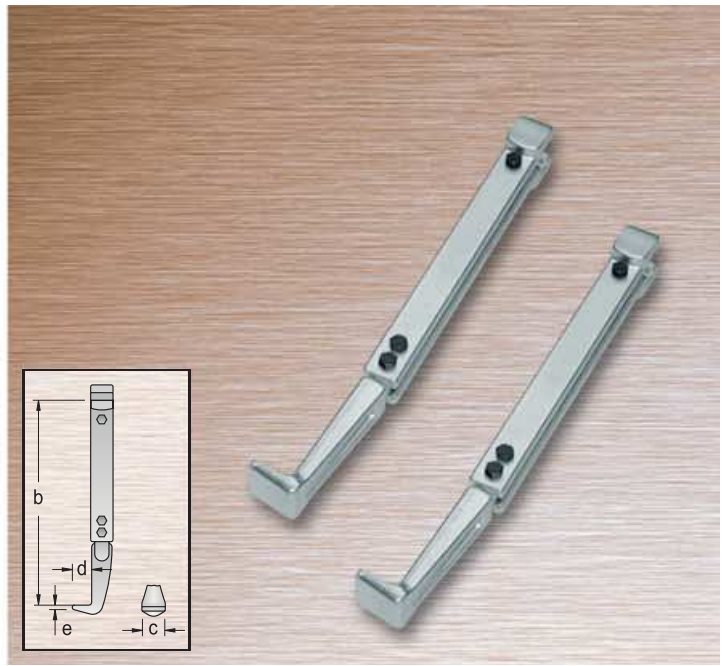

### 1.06 Pulling hooks

set of 2 pieces, rigid pattern

| Code    | No.      | †††                      | b   | c  | d  | e   | ☺☺  |
|---------|----------|--------------------------|-----|----|----|-----|-----|
| 8036260 | 1.06/100 | 1.06/11 1.06/1A1         | 100 | 22 | 15 | 3,0 | 0,4 |
| 8111490 | 1.06/150 | 1.06/21 1.06/2A1         | 150 | 30 | 24 | 3,5 | 1,1 |
| 8036420 | 1.06/200 | 1.06/31 1.06/3A1 1.06/41 | 200 | 36 | 32 | 5,0 | 2,4 |



### 1.06 Pulling hooks

set of 2 pieces, slim pattern

The forged hook feet are very shallow and thus particularly suitable for barely-accessible places.

| Code    | No.        | †††              | b   | c  | d | e   | f  | ☺☺  |
|---------|------------|------------------|-----|----|---|-----|----|-----|
| 1175513 | 1.06/S100  | 1.06/S1 1.06/S1A | 100 | 27 | 6 | 3,6 | 13 | 0,5 |
| 1175548 | 1.06/S200  | 1.06/S1 1.06/S1A | 200 | 27 | 6 | 3,6 | 13 | 1,0 |
| 1175556 | 1.06/S250  | 1.06/S1 1.06/S1A | 250 | 27 | 6 | 3,6 | 13 | 1,2 |
| 1554840 | 1.06/S100S | 1.06/S1 1.06/S1A | 100 | 27 | 6 | 2,3 | 13 | 0,5 |
| 1554859 | 1.06/S200S | 1.06/S1 1.06/S1A | 200 | 27 | 6 | 2,3 | 13 | 1,0 |
| 1554867 | 1.06/S250S | 1.06/S1 1.06/S1A | 250 | 27 | 6 | 2,3 | 13 | 1,2 |
| 1175564 | 1.06/S150  | 1.06/S2 1.06/S2A | 150 | 40 | 8 | 5,0 | 17 | 1,3 |
| 1175572 | 1.06/S220  | 1.06/S2 1.06/S2A | 220 | 40 | 8 | 5,0 | 17 | 1,7 |
| 1175580 | 1.06/S300  | 1.06/S2 1.06/S2A | 300 | 40 | 8 | 5,0 | 17 | 2,2 |

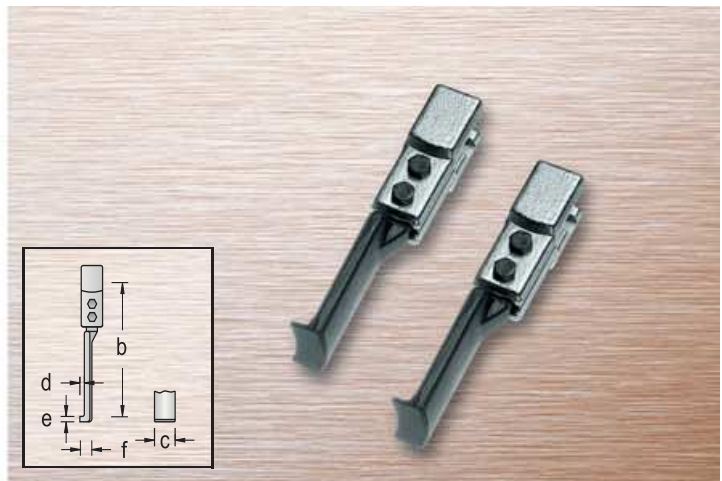

### 1.06 Fast clamping pulling hooks

set of 2 pieces

With the innovative high-speed clamps, fast and uncomplicated setting-up and readjustment is child's play.

| Code    | No.      | †††                | b   | c  | d  | e   | ☺☺  |
|---------|----------|--------------------|-----|----|----|-----|-----|
| 1221213 | 1.06/A-E | 1.06/1-E 1.06/1A-E | 100 | 22 | 12 | 3,0 | 0,6 |
| 1221221 | 1.06/B-E | 1.06/2-E 1.06/2A-E | 150 | 30 | 18 | 3,5 | 1,6 |
| 1221248 | 1.06/C-E | 1.06/3-E 1.06/3A-E | 200 | 36 | 28 | 6,5 | 3,5 |



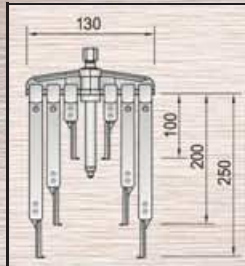
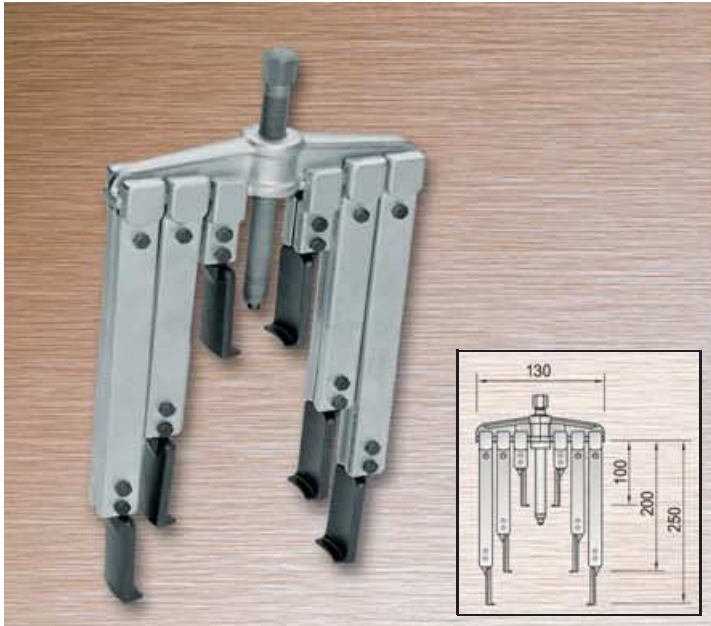

**1.06 AS Puller set**  
**2-arm pattern with 6 slim hooks**

With very slim forged hooks, thus particularly suitable for barely-accessible places.

| Code    | No.     | Contents 2 each     |     |
|---------|---------|---------------------|-----|
| 8001710 | 1.06/AS | 1.06/S100 S200 S250 | 3.3 |



**1.06 Puller set**  
**with display stand**

| Code    | No.       |                                |      |
|---------|-----------|--------------------------------|------|
| 8111570 | 1.06/ST   | 1.06/1 /1A /2 /2A /3           | 17.5 |
| 8111650 | 1.06/ST1  | 1.06/11 /1A1 /21 /2A1 /31      | 15.0 |
| 1322745 | 1.06/ST-E | 1.06/1-E /1A-E /2-E /2A-E /3-E | 20.0 |

9

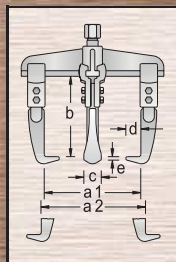
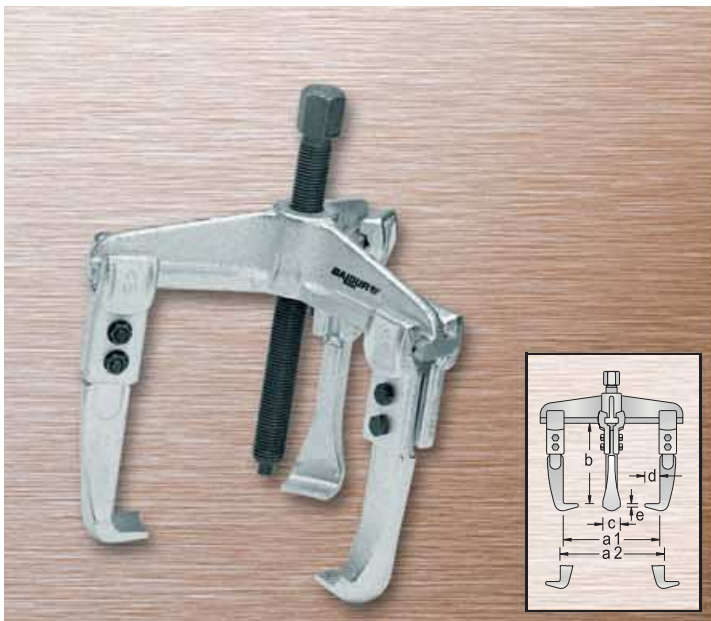

**1.07 Universal puller**  
**3-arm pattern**

For use as internal or external puller. The even load distribution on the three pulling hooks guarantees secure grip and central pulling. Hooks in special lengths available. Hooks 1.07/AV (clamping reach 200 mm) for 1.07/1 and 1.07/1A, and hooks 1.07/BV (clamping reach 300 mm) for 1.07/2 and 1.07/2A. Spindle may be exchanged for hydraulic pressure spindle (see table).

| Code    | No.     | a <sub>1</sub> | a <sub>2</sub> min | a <sub>2</sub> max | b   | Hydraulic spindle | mm        | c  | d  | e   | max. t |     |     |
|---------|---------|----------------|--------------------|--------------------|-----|-------------------|-----------|----|----|-----|--------|-----|-----|
| 8113940 | 1.07/1  | 90             | 70                 | 140                | 100 | M 14x1,5 x 140    | 17        | 22 | 12 | 3,0 | 3,0    | 1.4 |     |
| 8114080 | 1.07/1A | 130            | 80                 | 180                | 100 | M 14x1,5 x 140    | 17        | 22 | 12 | 3,0 | 3,0    | 1.6 |     |
| 8114160 | 1.07/2  | 160            | 100                | 220                | 150 | G 1/2 x 210       | 1.06/HSP1 | 22 | 30 | 18  | 3,5    | 5,0 | 3.6 |
| 8114240 | 1.07/2A | 200            | 100                | 260                | 150 | G 1/2 x 210       | 1.06/HSP1 | 22 | 30 | 18  | 3,5    | 5,0 | 4.0 |
| 1541757 | 1.07/3  | 250            | 100                | 400                | 200 | G 3/4 x 280       | 1.06/HSP2 | 27 | 36 | 28  | 6,5    | 7,5 | 9.0 |

### 1.07/4 Universal puller

#### 3-arm pattern

Just like our standard model No. 1.06, this puller is designed for all branches of industry, but particularly for the construction of electric motors. It is also suitable for removing heavy, multistage pulley wheels, flywheels, gear wheels, etc.

Pins are used to lock the arms at 120° to each other on the hub. The clamping reach may be extended to 490 mm by using extensions No. 1.07/CV, 1.07/DV and 1.07/EV. Spindle may be exchanged for hydraulic pressure spindle (see table).

This puller may also be used with the hydraulic aid 1.50 without requiring any reduction bushing.

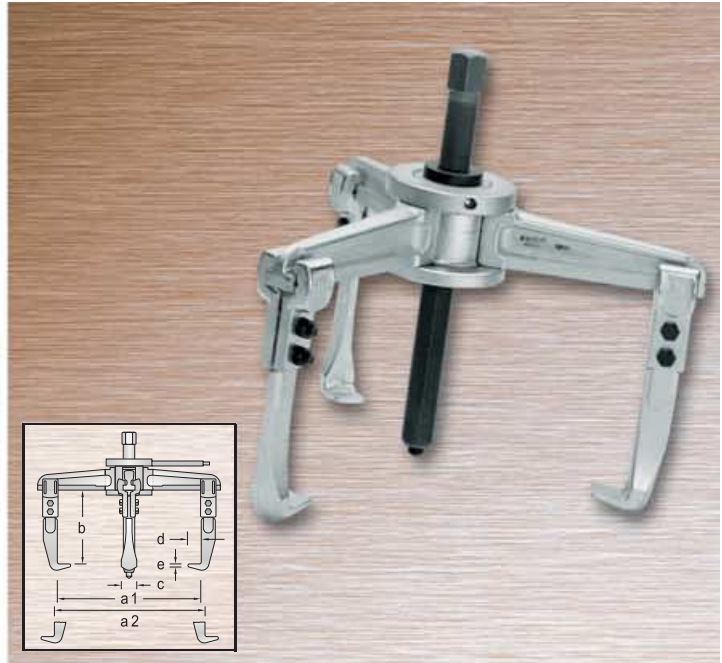

| Code    | No.    | a <sub>1</sub> | a <sub>2</sub> | b   | ⌀         | Hydraulic spindle | mm | c  | d  | e   | max. t | ⌀    |
|---------|--------|----------------|----------------|-----|-----------|-------------------|----|----|----|-----|--------|------|
| 8002440 | 1.07/4 | 450            | 530            | 200 | G 1 x 360 | 1.06/HSP3         | 36 | 36 | 28 | 6,5 | 10     | 19,0 |

### 1.07 Universal puller

#### 3-arm pattern, with slim hooks

The feet of the hooks are very slim and particularly suitable for barely-accessible places.

| Code    | No.      | a   | b   | ⌀              | mm | c  | d | e   | f  | max. t | ⌀   |
|---------|----------|-----|-----|----------------|----|----|---|-----|----|--------|-----|
| 8116450 | 1.07/S1  | 90  | 100 | M 14x1,5 x 140 | 17 | 27 | 6 | 3,6 | 13 | 2,5    | 1,3 |
| 8116530 | 1.07/S1A | 130 | 100 | M 14x1,5 x 140 | 17 | 27 | 6 | 3,6 | 13 | 2,5    | 1,4 |
| 8116610 | 1.07/S2  | 160 | 150 | G 1/2 x 210    | 22 | 40 | 8 | 5,0 | 17 | 5,0    | 3,6 |
| 8116880 | 1.07/S2A | 200 | 150 | G 1/2 x 210    | 22 | 40 | 8 | 5,0 | 17 | 5,0    | 4,0 |

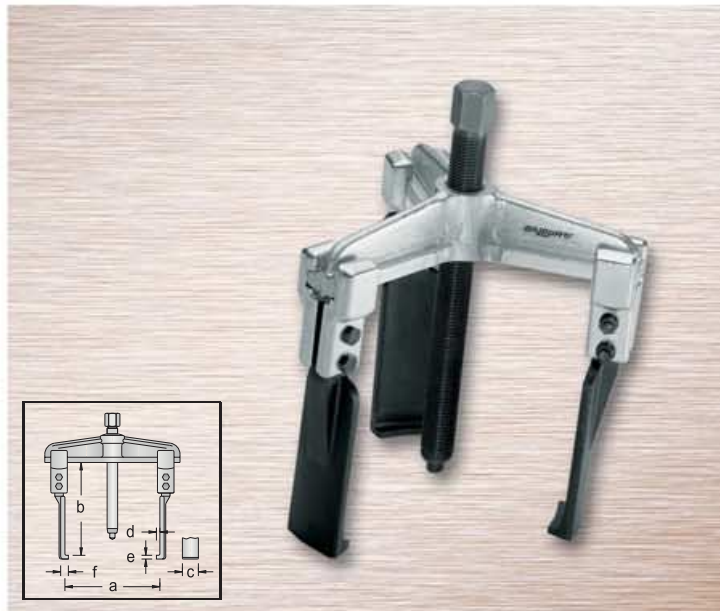

### 1.07 Universal puller

#### 3-arm pattern, with rigid hooks

Design as universal puller No. 1.07/1 to 1.07/3, but with rigid pulling hooks. For greater ease in setting the clamping spread. The hooks clamp automatically when under tension.

The hooks may be reversed to convert the puller from an external one to an internal one. Spindle may be exchanged for hydraulic pressure spindle (see table).

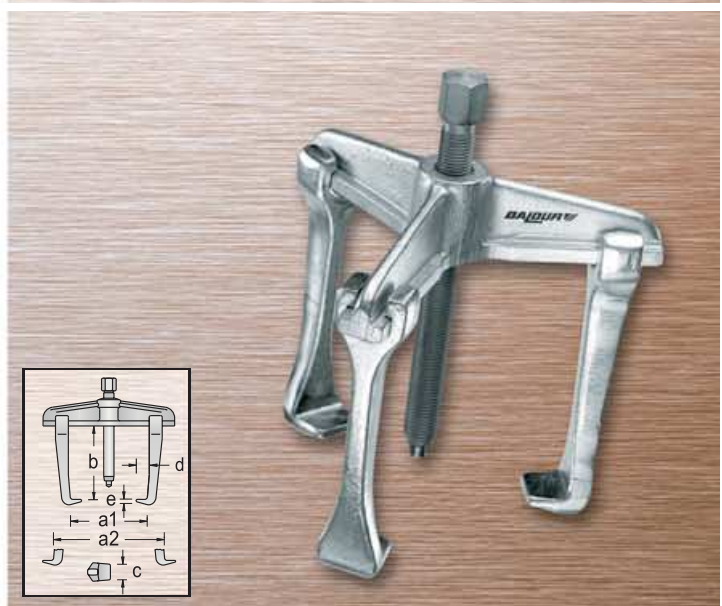

| Code    | No.      | a <sub>1</sub> | a <sub>2</sub> min | a <sub>2</sub> max | b   | ⌀              | Hydraulic spindle | mm | c  | d  | e   | max. t | ⌀   |
|---------|----------|----------------|--------------------|--------------------|-----|----------------|-------------------|----|----|----|-----|--------|-----|
| 1305549 | 1.07/11  | 90             | 70                 | 140                | 100 | M 14x1,5 x 140 |                   | 17 | 22 | 15 | 4,0 | 3,0    | 1,3 |
| 1306022 | 1.07/1A1 | 130            | 80                 | 180                | 100 | M 14x1,5 x 140 |                   | 17 | 22 | 15 | 4,0 | 3,0    | 1,5 |
| 1306154 | 1.07/21  | 160            | 100                | 220                | 150 | G 1/2 x 210    | 1.06/HSP1         | 22 | 30 | 24 | 3,5 | 5,0    | 3,0 |
| 1306278 | 1.07/2A1 | 200            | 100                | 260                | 150 | G 1/2 x 210    | 1.06/HSP1         | 22 | 30 | 24 | 3,5 | 5,0    | 3,2 |
| 1554778 | 1.07/31  | 250            | 100                | 400                | 200 | G 3/4 x 280    | 1.06/HSP2         | 27 | 36 | 28 | 6,5 | 7,5    | 9,0 |

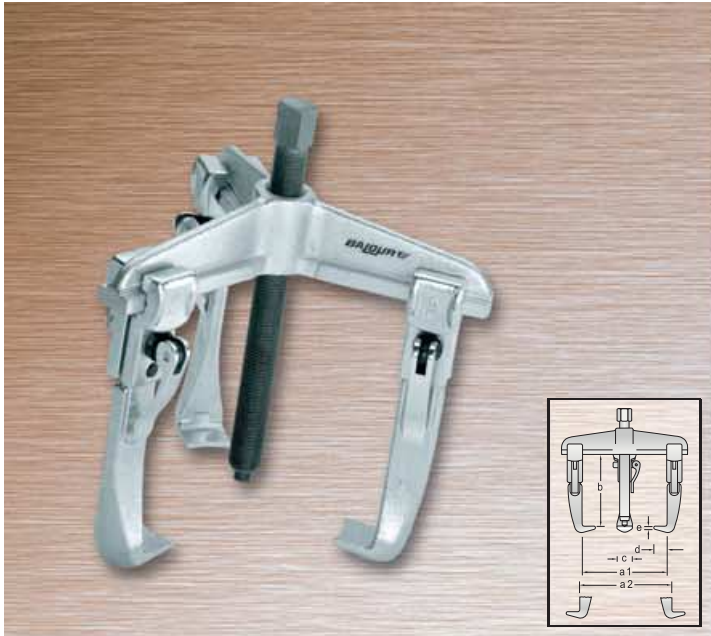

**1.07 Fast clamping puller**  
**3-arm pattern, with fast-clamp adjustment**

May be used as an internal or external puller. The even distribution of the loading over the three hooks results in secure grip and centered pulling action. With the innovative high-speed clamps, fast and uncomplicated setting-up and readjustment is child's play. Spindle may be exchanged for hydraulic pressure spindle (see table).

| Code    | No.       | a <sub>1</sub> | a <sub>2</sub> min | a <sub>2</sub> max | b   | Hydraulic spindle | mm        | c  | d  | e   | max. t |     |     |
|---------|-----------|----------------|--------------------|--------------------|-----|-------------------|-----------|----|----|-----|--------|-----|-----|
| 1222902 | 1.07/1-E  | 90             | 70                 | 140                | 100 | M 14x1,5 x 140    | 17        | 22 | 12 | 3,0 | 3,0    | 1.4 |     |
| 1225901 | 1.07/1A-E | 130            | 80                 | 180                | 100 | M 14x1,5 x 140    | 17        | 22 | 12 | 3,0 | 3,0    | 1.6 |     |
| 1227335 | 1.07/2-E  | 160            | 100                | 220                | 150 | G 1/2 x 210       | 1.06/HSP1 | 22 | 30 | 18  | 3,5    | 5,0 | 3.6 |
| 1227459 | 1.07/2A-E | 200            | 100                | 260                | 150 | G 1/2 x 210       | 1.06/HSP1 | 22 | 30 | 18  | 3,5    | 5,0 | 4.0 |
| 1554751 | 1.07/3-E  | 250            | 100                | 400                | 200 | G 3/4 x 280       | 1.06/HSP2 | 27 | 36 | 28  | 6,5    | 7,5 | 9.0 |

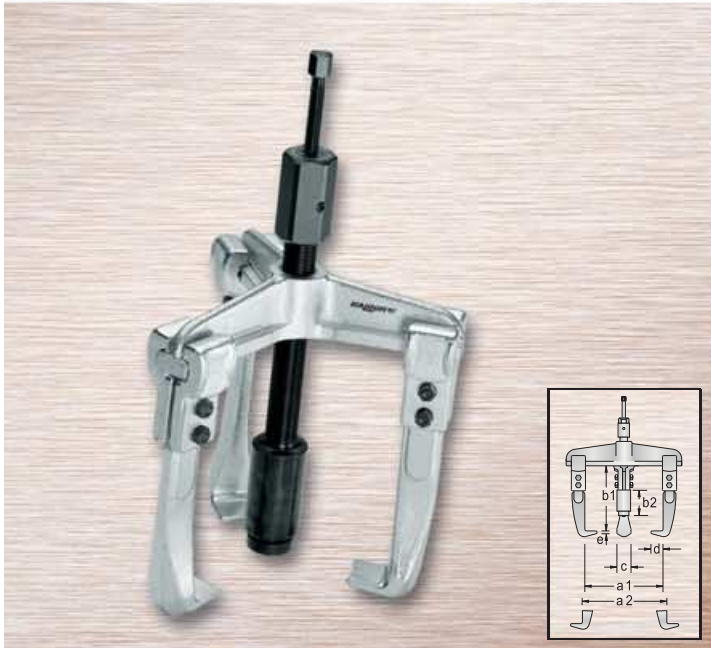

**1.07 HSP Universal puller**  
**hydraulic, 3-arm pattern**

The tried and tested model for the removal of pulleys, wheels, ball bearings, etc. Drop forged pattern. By reversing the hooks, this tool may be used as an internal or external puller. With the hydraulic spindle, a controlled and safe pulling action is possible at all times.

| Code    | No.          | a <sub>1</sub> | a <sub>2</sub> | b  | Spindle   | c  | d  | e   | max. t |      |
|---------|--------------|----------------|----------------|----|-----------|----|----|-----|--------|------|
| 8009960 | 1.07/2-HSP1  | 160            | 220            | 75 | 1.06/HSP1 | 30 | 18 | 3,5 | 5,0    | 4.4  |
| 8010970 | 1.07/2A-HSP1 | 200            | 260            | 75 | 1.06/HSP1 | 30 | 18 | 3,5 | 5,0    | 4.8  |
| 1554816 | 1.07/3-HSP2  | 250            | 100            | 80 | 1.06/HSP2 | 36 | 28 | 6,5 | 7,5    | 9.3  |
| 8012400 | 1.07/4-HSP3  | 450            | 530            | 80 | 1.06/HSP3 | 36 | 28 | 6,5 | 10,0   | 19.4 |

9

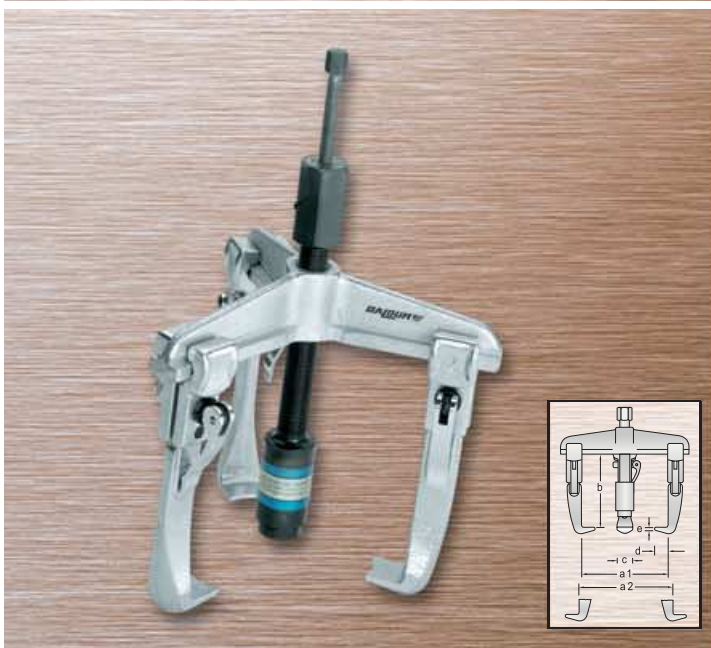

**1.07 HSP Fast clamping puller**  
**hydraulic, 3-arm pattern**

With the hydraulic spindle, a controlled and safe pulling action is possible at all times. With the innovative high-speed clamps, fast and uncomplicated setting-up and readjustment is child's play.

| Code    | No.            | a <sub>1</sub> | a <sub>2</sub> | b  | Spindle   | c  | d  | e   | max. t |     |
|---------|----------------|----------------|----------------|----|-----------|----|----|-----|--------|-----|
| 1221922 | 1.07/2-E-HSP1  | 160            | 220            | 75 | 1.06/HSP1 | 30 | 18 | 3,5 | 5,0    | 4.5 |
| 1222554 | 1.07/2A-E-HSP1 | 200            | 260            | 75 | 1.06/HSP1 | 30 | 18 | 3,5 | 5,0    | 4.7 |
| 1554824 | 1.07/3-E-HSP2  | 250            | 400            | 80 | 1.06/HSP2 | 36 | 28 | 6,5 | 7,5    | 9.3 |



### 1.07 Extension for pullers

set of 3 pieces

The one-piece drop forged extensions enable the clamping reach to be extended. The extensions may be used together with all hooks of the 1.07 range.

| Code    | No.       | ††                      | b   | ↻   |
|---------|-----------|-------------------------|-----|-----|
| 1307576 | 1.07/V100 | for 1.07/A and 1.07/100 | 100 | 0.4 |
| 1307584 | 1.07/V150 | for 1.07/B and 1.07/150 | 150 | 1.6 |
| 1307592 | 1.07/V200 | for 1.07/C and 1.07/200 | 200 | 2.6 |



### 1.07 Pulling hooks

set of 3 pieces

| Code    | No.      | ††             | b   | c  | d   | e   | ↻    |
|---------|----------|----------------|-----|----|-----|-----|------|
| 1307401 | 1.07/A   | 1.07/1 1.07/1A | 100 | 22 | 12  | 3,0 | 0.9  |
| 1307428 | 1.07/B   | 1.07/2 1.07/2A | 150 | 30 | 118 | 3,5 | 2.4  |
| 1307436 | 1.07/C   | 1.07/3 1.07/4  | 200 | 36 | 28  | 6,5 | 5.2  |
| 1307452 | 1.07/A-E | 1.07/1 1.07/1A | 100 | 22 | 12  | 3,0 | 0.9  |
| 1307460 | 1.07/B-E | 1.07/2 1.07/2A | 150 | 30 | 18  | 3,5 | 0.9  |
| 1307479 | 1.07/C-E | 1.07/3 1.07/4  | 200 | 36 | 28  | 6,5 | 8.0  |
| 1307487 | 1.07/AV  | 1.07/1 1.07/1A | 200 | 22 | 12  | 3,0 | 1.6  |
| 1307495 | 1.07/BV  | 1.07/2 1.07/2A | 300 | 30 | 18  | 3,5 | 4.2  |
| 1307509 | 1.07/CV  | 1.07/3 1.07/4  | 300 | 36 | 28  | 6,5 | 7.5  |
| 1307517 | 1.07/DV  | 1.07/3 1.07/4  | 400 | 36 | 28  | 6,5 | 9.4  |
| 1307525 | 1.07/EV  | 1.07/3 1.07/4  | 500 | 36 | 28  | 6,5 | 11.2 |

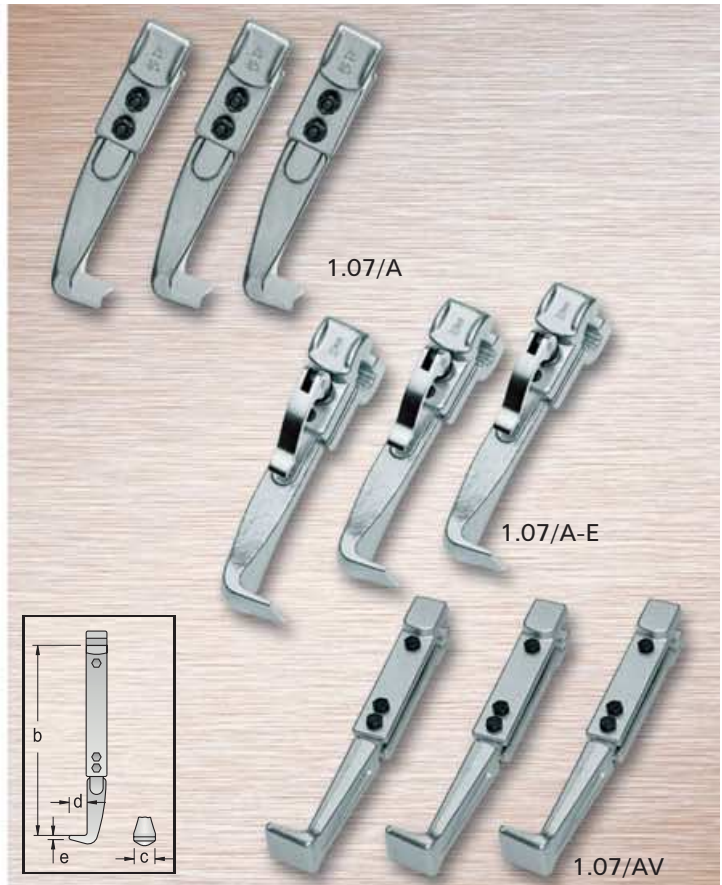

### 1.07 Pulling hooks

set of 3 pieces, rigid pattern

for 3-arm pullers.

| Code    | No.      | ††               | b   | c  | d  | e   | ↻   |
|---------|----------|------------------|-----|----|----|-----|-----|
| 1307533 | 1.07/100 | 1.07/11 1.07/1A1 | 100 | 22 | 15 | 3,0 | 0.6 |
| 1307541 | 1.07/150 | 1.07/21 1.07/2A1 | 150 | 30 | 24 | 3,5 | 1.6 |
| 1307568 | 1.07/200 | 1.07/3 1.07/4    | 200 | 36 | 32 | 5,0 | 3.7 |



### 1.07 Pulling hooks

set of 3 pieces, slim pattern

The feet of the hooks are very slim and thus particularly suitable for barely-accessible places.

| Code    | No.        | ††               | b   | c  | d | e   | f  | ↻   |
|---------|------------|------------------|-----|----|---|-----|----|-----|
| 1307606 | 1.07/S100  | 1.07/S1 1.07/S1A | 100 | 27 | 6 | 3,6 | 13 | 1.2 |
| 1307622 | 1.07/S200  | 1.07/S1 1.07/S1A | 200 | 27 | 6 | 3,6 | 13 | 2.4 |
| 1307630 | 1.07/S250  | 1.07/S1 1.07/S1A | 250 | 27 | 6 | 3,6 | 13 | 3.0 |
| 1554786 | 1.07/S100S | 1.07/S1 1.07/S1A | 100 | 27 | 6 | 2,3 | 13 | 0.8 |
| 1554794 | 1.07/S200S | 1.07/S1 1.07/S1A | 200 | 27 | 6 | 2,3 | 13 | 1.6 |
| 1554808 | 1.07/S250S | 1.07/S1 1.07/S1A | 250 | 27 | 6 | 2,3 | 13 | 2.0 |
| 1307649 | 1.07/S150  | 1.07/S2 1.07/S2A | 150 | 40 | 8 | 5,0 | 17 | 2.7 |
| 1307657 | 1.07/S220  | 1.07/S2 1.07/S2A | 220 | 40 | 8 | 5,0 | 17 | 3.4 |
| 1307665 | 1.07/S300  | 1.07/S2 1.07/S2A | 300 | 40 | 8 | 5,0 | 17 | 5.0 |





**1.07 AS Puller set**  
**3-arm pattern with 9 slim hooks**

The feet of the hooks are very slim and thus particularly suitable for barely-accessible places.

| Code    | No.     | Contents 3 each     |     |
|---------|---------|---------------------|-----|
| 8117260 | 1.07/AS | 1.07/S100 S200 S250 | 4.3 |



**1.07/KSE Puller set**

Contents: case, spindle, 1 cross piece each 2-arm and 3-arm pattern and 3 puller hooks length 100 mm.

| Code    | No.         |     |
|---------|-------------|-----|
| 1438484 | 1.07/K-1-SE | 2.1 |



**1.07 K Puller set**  
**with 9 hooks, in plastic case**

Contents: case, spindle, 1 cross piece each 2-arm and 3-arm pattern and 9 puller hooks in length 100, 200, 250 mm.

| Code    | No.    | a <sub>max</sub> | b <sub>1</sub> | b <sub>2</sub> | b <sub>3</sub> |                |    | c  | d | e   |     |
|---------|--------|------------------|----------------|----------------|----------------|----------------|----|----|---|-----|-----|
| 8117340 | 1.07/K | 120              | 100            | 200            | 250            | M 14x1,5 x 140 | 17 | 27 | 6 | 3,6 | 5.0 |

9



**1.07 Puller set**  
**in plastic case**

With three quick-clamping hooks and hydraulic spindle. Suitable for internal and external pulling work, 2-arm or 3-arm, with powerful hydraulic spindle and quick-clamping hooks. The right puller for the job - and ready in a second. The best equipment for the professional for everyday heavy duty work. For industrial or car and truck repairs - set of two. Your price advantage: 1 spindle and 2 hooks saved. Hydraulic spindle HSP1 (max. 12 t force). Three quick-clamping hooks for internal and external use. Heavy duty cross pieces for 2-arm or 3-arm use. And everything stored safely in a handy case. Contents: case, spindle, 1 cross piece each 2-arm and 3-arm, 3 puller hooks.

| Code    | No.             | a <sub>1</sub> | a <sub>2</sub> | b  |           |    | c  | d | e |     |
|---------|-----------------|----------------|----------------|----|-----------|----|----|---|---|-----|
| 1438492 | 1.07/K-2-E-HSP1 | 160            | 220            | 75 | 1.06/HSP1 | 30 | 18 | 3 | 5 | 2.1 |



### 1.08 Universal puller

#### 2-arm pattern, with fast spindle adjustment

Twice as fast and twice as simple.  
 With the fast spindle adjustment feature, the spindle can be set the desired range in a moment.  
 When the clamping yoke is released, the 4-part internal thread closes, and takes the full working pressure.

| Code    | No.     | a <sub>1</sub> | a <sub>2 min</sub> | a <sub>2 max</sub> | b   |                | mm | c  | d  | e   | max. t |      |
|---------|---------|----------------|--------------------|--------------------|-----|----------------|----|----|----|-----|--------|------|
| 8019090 | 1.08/1A | 130            | 80                 | 180                | 100 | M 14x1,5 x 140 | 17 | 22 | 12 | 3,0 | 3,0    | 1.4  |
| 8000070 | 1.08/2A | 200            | 110                | 260                | 150 | G 1/2 x 210    | 22 | 30 | 18 | 3,5 | 5,0    | 3.8  |
| 8018950 | 1.08/3A | 350            | 130                | 420                | 200 | G 3/4 x 280    | 27 | 36 | 28 | 6,5 | 7,5    | 10.2 |

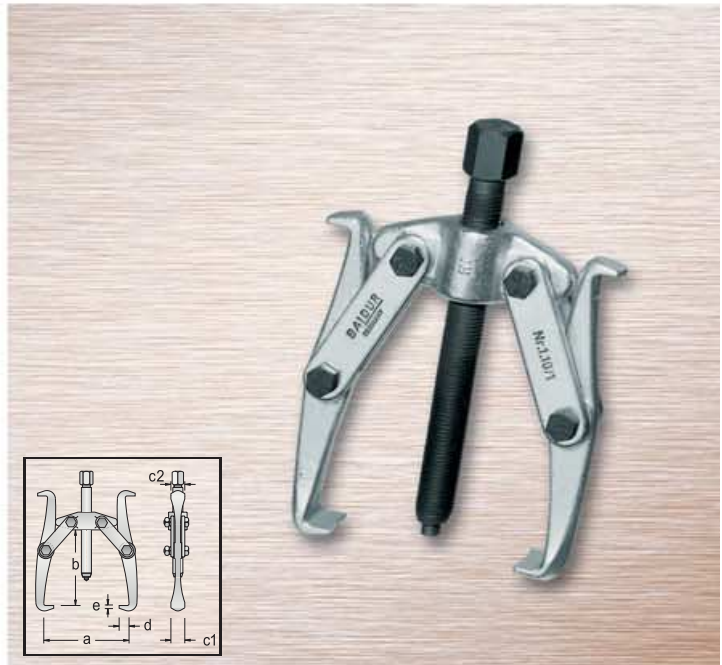

### 1.10 Puller

#### 2-arm pattern

The reliable, heavy duty model for the removal of pulleys, wheels, ball bearings, etc.  
 The double hook ends, wide or narrow, grip automatically.  
 The wide hook ends of the puller 1.10/2 and 1.11/2 possess 8 mm slots, so that pulleys or gears may also be pulled off using 8 mm bolts.

| Code    | No.    | a <sub>max</sub> | b   |                | mm | c <sub>1</sub> | c <sub>2</sub> | d  | e | max. t |     |
|---------|--------|------------------|-----|----------------|----|----------------|----------------|----|---|--------|-----|
| 8002600 | 1.10/1 | 90               | 80  | M 14x1,5 x 125 | 17 | 17             | 10             | 7  | 2 | 2      | 0.7 |
| 8002790 | 1.10/2 | 160              | 130 | M 18x1,5 x 170 | 19 | 24             | 20             | 13 | 3 | 5      | 2.0 |

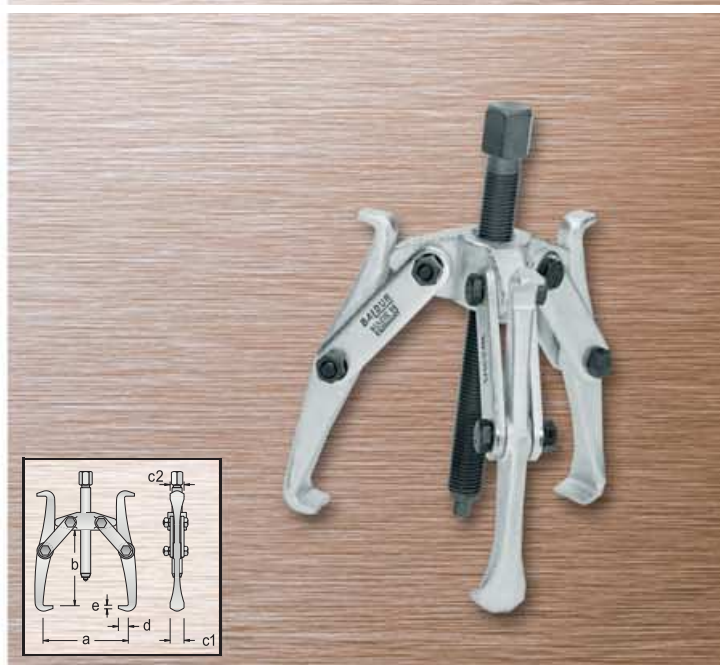

### 1.11 Puller

#### 3-arm pattern

The reliable, heavy-duty model for the removal of pulleys, wheels, ball bearings, etc. The double hook ends, wide or narrow, grip automatically.  
 The wide hook ends of the puller 1.10/2 and 1.11/2 possess 8 mm slots, so that pulleys or gears may also be pulled off using 8 mm bolts.

| Code    | No.    | a <sub>max</sub> | b   |                | mm | c <sub>1</sub> | c <sub>2</sub> | d  | e | max. t |     |
|---------|--------|------------------|-----|----------------|----|----------------|----------------|----|---|--------|-----|
| 8002950 | 1.11/1 | 90               | 80  | M 14x1,5 x 125 | 17 | 17             | 10             | 7  | 2 | 3,0    | 0.9 |
| 8003090 | 1.11/2 | 160              | 130 | M 18x1,5 x 170 | 19 | 24             | 20             | 13 | 3 | 7,5    | 2.7 |



**1.12 Puller**  
**2-arm pattern**

Handy robust model for the removal of pulleys, wheels, ball bearings, etc. Inexpensive economy model. The hook tips grip automatically.

| Code    | No.    | a <sub>max</sub> | b   | —              | ●mm | c  | d  | e   | max. t | ↺↻  |
|---------|--------|------------------|-----|----------------|-----|----|----|-----|--------|-----|
| 8003250 | 1.12/0 | 70               | 80  | M 12x1,5 x 110 | 14  | 14 | 8  | 2,0 | 1      | 0.4 |
| 8003330 | 1.12/1 | 90               | 120 | M 14x1,5 x 155 | 17  | 18 | 11 | 2,5 | 2      | 0.7 |
| 8003410 | 1.12/2 | 130              | 160 | M 18x1,5 x 200 | 19  | 25 | 14 | 3,0 | 5      | 1.9 |
| 8003680 | 1.12/3 | 180              | 200 | G 1/2 x 250    | 22  | 32 | 20 | 3,5 | 8      | 3.7 |

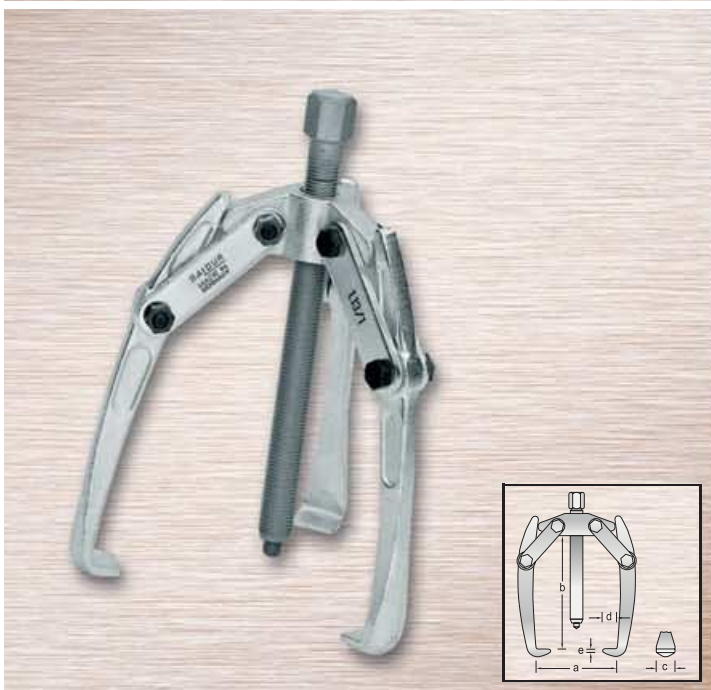

**1.13 Puller**  
**3-arm pattern**

Handy robust model for the removal of pulleys, wheels, ball bearings, etc. Inexpensive economy model. The hook tips grip automatically.

| Code    | No.    | a <sub>max</sub> | b   | —              | ●mm | c  | d  | e   | max. t | ↺↻  |
|---------|--------|------------------|-----|----------------|-----|----|----|-----|--------|-----|
| 8004140 | 1.13/0 | 70               | 80  | M 12x1,5 x 110 | 14  | 14 | 8  | 2,0 | 1,5    | 0.5 |
| 8004220 | 1.13/1 | 90               | 120 | M 14x1,5 x 155 | 17  | 18 | 11 | 2,5 | 3,0    | 1.0 |
| 8004300 | 1.13/2 | 130              | 160 | M 18x1,5 x 200 | 19  | 25 | 14 | 3,0 | 7,5    | 2.6 |
| 8004490 | 1.13/3 | 180              | 200 | G 1/2 x 250    | 22  | 32 | 20 | 3,5 | 12,0   | 5.1 |

9



**1.12 Battery-terminal puller**  
**2-arm pattern**

The perfect tool for removing small parts such as battery terminals, pulleys, wheels, ball bearings, etc. The hook tips grip automatically.

| Code    | No.     | a <sub>max</sub> | b  | —             | c  | d | e | max. t | ↺↻  |
|---------|---------|------------------|----|---------------|----|---|---|--------|-----|
| 8003760 | 1.12/01 | 60               | 60 | M 10x1,5 x 80 | 10 | 5 | 2 | 0,5    | 160 |
| 8003840 | 1.12/02 | 60               | 40 | M 10x1,5 x 60 | 10 | 5 | 2 | 0,5    | 120 |

### 1.13 Battery-terminal puller

#### 3-arm pattern

The perfect tool for removing small parts such as battery terminals, pulleys, wheels, ball bearings, etc. The hook tips grip automatically.

| Code    | No.     | a <sub>max</sub> | b  | ⌀             | c  | d | e | max. t | ↕   |
|---------|---------|------------------|----|---------------|----|---|---|--------|-----|
| 8004570 | 1.13/01 | 60               | 60 | M 10x1,5 x 80 | 10 | 5 | 2 | 0,75   | 200 |
| 8004650 | 1.13/02 | 60               | 40 | M 10x1,5 x 60 | 10 | 5 | 2 | 0,75   | 150 |

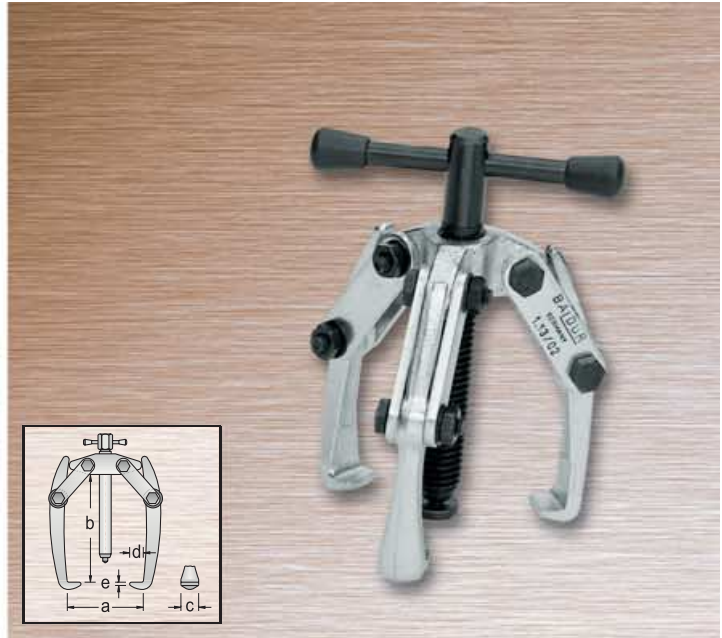
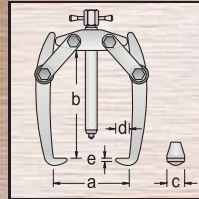

### 1.14 Puller

#### 2-arm pattern

The reliable, extra-strong model for the removal of pulleys, wheels, ball bearings, etc. With technical and economical benefits due to the variable clamping reach and automatic grip of the hooks. Especially suited to removing V-belt pulley wheels and flywheels mounted on longer shafts. Spindle may be exchanged for hydraulic pressure spindle (see table).

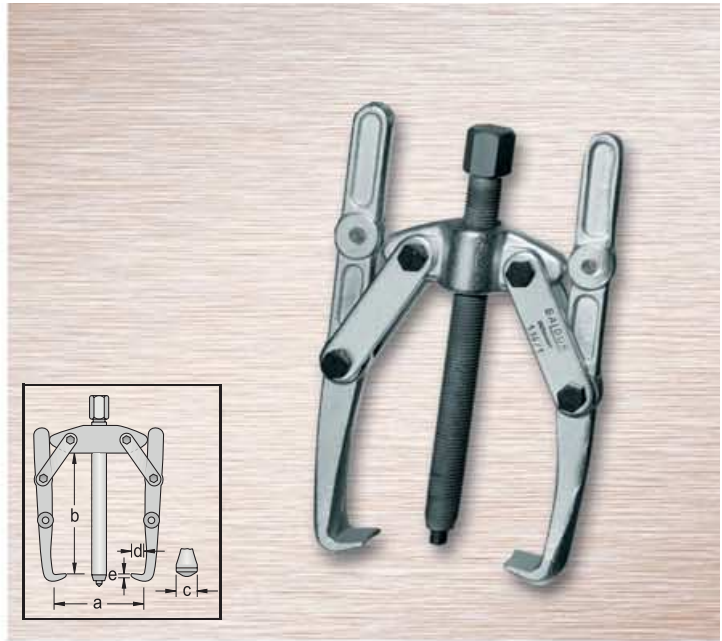
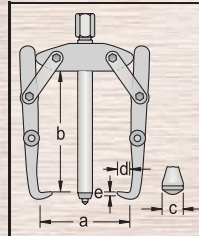

| Code    | No.    | a <sub>max</sub> | b   | ⌀              | Hydraulic spindle | ●mm | c  | d  | e   | max. t | ↕    |
|---------|--------|------------------|-----|----------------|-------------------|-----|----|----|-----|--------|------|
| 8004810 | 1.14/0 | 90               | 100 | M 12x1,5 x 110 |                   | 14  | 14 | 9  | 2,0 | 1      | 500  |
| 8005030 | 1.14/1 | 130              | 140 | M 14x1,5 x 140 |                   | 17  | 18 | 11 | 2,0 | 2      | 800  |
| 8005380 | 1.14/2 | 200              | 210 | M 18x1,5 x 200 |                   | 19  | 25 | 16 | 3,0 | 5      | 2100 |
| 8005460 | 1.14/3 | 250              | 260 | G 1/2 x 250    | 1.06/HSP1         | 24  | 32 | 18 | 3,5 | 8      | 4300 |
| 8005540 | 1.14/4 | 280              | 390 | G 1/2 x 250    | 1.06/HSP1         | 24  | 32 | 20 | 3,5 | 8      | 5100 |
| 8005620 | 1.14/5 | 420              | 480 | G 1/2 x 350    | 1.06/HSP1         | 24  | 32 | 20 | 3,5 | 8      | 5800 |

### 1.14 HSP Puller

#### hydraulic, 2-arm pattern

The reliable, extra-strong model for the removal of pulleys, wheels, ball bearings, etc. With technical and economical benefits due to the variable clamping reach and automatic grip of the hooks. Especially suited to removing V-belt pulley wheels and flywheels mounted on longer shafts.

With the hydraulic spindle, a controlled and safe pulling action is possible at all times.

| Code    | No.         | a <sub>max</sub> | b   | ⌀         | ●mm | c  | d  | e   | max. t | ↕   |
|---------|-------------|------------------|-----|-----------|-----|----|----|-----|--------|-----|
| 1392883 | 1.14/3-HSP1 | 250              | 260 | 1.06/HSP1 | 22  | 32 | 18 | 3,5 | 8      | 4.3 |
| 1392913 | 1.14/4-HSP1 | 280              | 390 | 1.06/HSP1 | 22  | 32 | 20 | 3,5 | 8      | 5.1 |



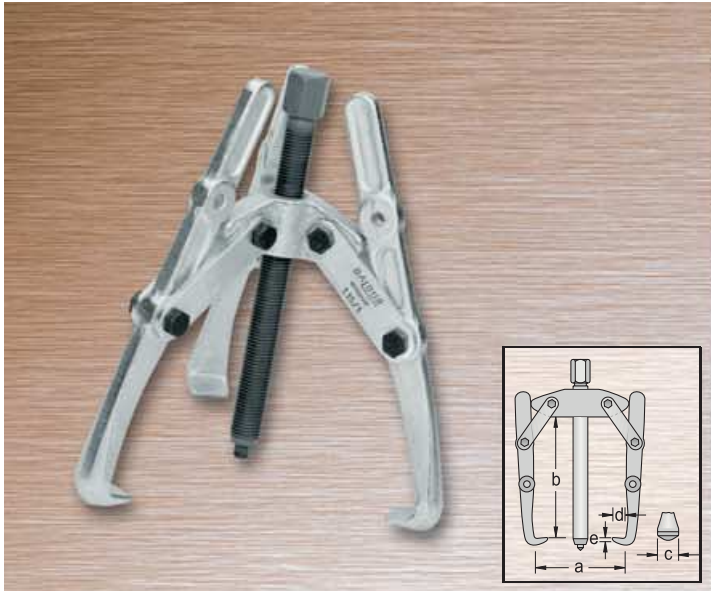

**1.15 Puller  
3-arm pattern**

The reliable, extra-strong model for the removal of pulleys, wheels, ball bearings, etc. With technical and economical benefits due to the variable clamping reach and automatic grip of the hooks. Especially suited to removing V-belt pulley wheels and flywheels mounted on longer shafts. Spindle may be exchanged for hydraulic pressure spindle (see table).

| Code    | No.    | a <sub>max</sub> | b   |                | Hydraulic spindle |    | c  | d  | e   | max. t |      |
|---------|--------|------------------|-----|----------------|-------------------|----|----|----|-----|--------|------|
| 8006000 | 1.15/0 | 90               | 100 | M 12x1,5 x 110 |                   | 14 | 14 | 9  | 2,0 | 2      | 650  |
| 8006190 | 1.15/1 | 130              | 140 | M 14x1,5 x 140 |                   | 17 | 18 | 11 | 2,0 | 3      | 1100 |
| 8006350 | 1.15/2 | 200              | 210 | M 18x1,5 x 200 |                   | 19 | 25 | 16 | 3,0 | 8      | 2900 |
| 8006430 | 1.15/3 | 250              | 260 | G 1/2 x 250    | 1.06/HSP1         | 24 | 32 | 18 | 3,5 | 12     | 6100 |
| 8006510 | 1.15/4 | 280              | 390 | G 1/2 x 250    | 1.06/HSP1         | 24 | 32 | 20 | 3,5 | 12     | 7100 |
| 8006780 | 1.15/5 | 420              | 480 | G 1/2 x 350    | 1.06/HSP1         | 24 | 32 | 20 | 3,5 | 12     | 8200 |



**1.15 HSP Puller  
hydraulic, 3-arm pattern**

The reliable, extra-strong model for the removal of pulleys, wheels, ball bearings, etc. With technical and economical benefits due to the variable clamping reach and automatic grip of the hooks. Especially suited to removing V-belt pulley wheels and flywheels mounted on longer shafts. With the hydraulic spindle, a controlled and safe pulling action is possible at all times.

| Code    | No.         | a <sub>max</sub> | b   |           |    | c  | d  | e   | max. t |     |
|---------|-------------|------------------|-----|-----------|----|----|----|-----|--------|-----|
| 1392956 | 1.15/3-HSP1 | 250              | 260 | 1.06/HSP1 | 22 | 32 | 18 | 3,5 | 12     | 6.1 |
| 1392980 | 1.15/4-HSP1 | 280              | 390 | 1.06/HSP1 | 22 | 32 | 20 | 3,5 | 12     | 7.1 |



**1.14 L Fan puller  
2-arm pattern**



The especially-slender hooks reach through the slots the collar of the fan. Due to their slender hooks and the three adjustment positions of its clamping reach, these pullers are also particularly suitable for the dismantling of gear arrangements. Hooks grip automatically.

| Code    | No.     | a <sub>max</sub> | b   |                |    | c  | d | e | max. t |     |
|---------|---------|------------------|-----|----------------|----|----|---|---|--------|-----|
| 8005110 | 1.14/1L | 150              | 200 | M 14x1,5 x 155 | 17 | 10 | 6 | 2 | 2      | 0.9 |

### 1.15 L Fan puller

#### 3-arm pattern

The especially-slender hooks reach through the slots the collar of the fan. Due to their slender hooks and the three adjustment positions of its clamping reach, these pullers are also particularly suitable for the dismantling of gear arrangements. Hooks grip automatically.

| Code    | No.     | a <sub>max</sub> | b   |  mm | c  | d  | e | max. t |  |     |
|---------|---------|------------------|-----|--|----|----|---|--------|---|-----|
| 8006270 | 1.15/1L | 150              | 200 | M 14x1,5 x 155   | 17 | 10 | 6 | 2      | 3   | 1.3 |





### 1.16 Puller

#### 2-arm pattern

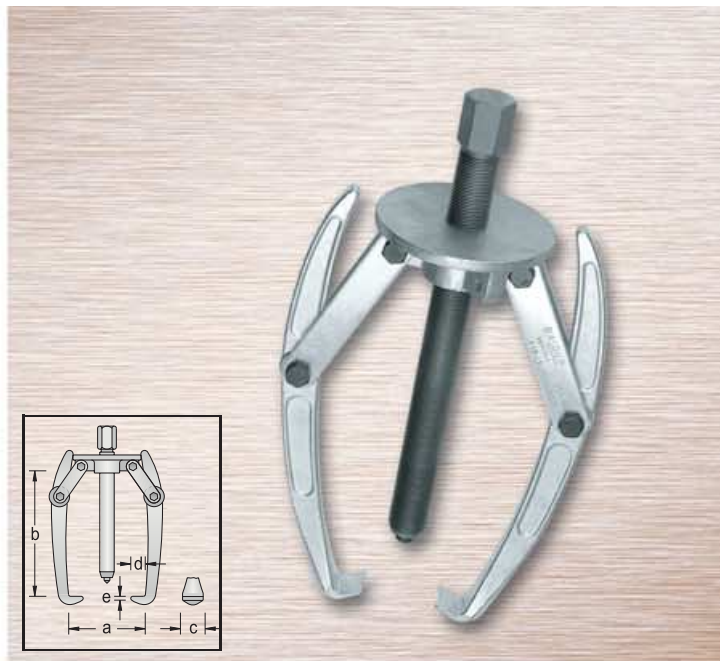
Very strong type. Especially suitable for industrial purposes and for heavy agricultural and construction machines. Hooks grip automatically. Spindle may be exchanged for hydraulic pressure spindle (see table).





| Code    | No.    | a <sub>max</sub> | b   |  mm | Hydraulic spindle | mm | c  | d  | e | max. t |  |
|---------|--------|------------------|-----|--|-------------------|----|----|----|---|--------|---|
| 8007080 | 1.16/1 | 280              | 300 | G 1 x 360  | 1.06/HSP3         | 36 | 32 | 19 | 3 | 8      | 8.0   |
| 8007160 | 1.16/2 | 420              | 420 | G 1 x 500  | 1.06/HSP3         | 36 | 32 | 22 | 3 | 8      | 10  |

### 1.16 HSP Puller

#### hydraulic, 2-arm pattern

Very strong type. Especially suitable for industrial purposes and for heavy agricultural and construction machines. Hooks grip automatically. With the hydraulic spindle, a controlled and safe pulling action is possible at all times.

| Code    | No.         | a <sub>max</sub> | b   |  mm | c  | d  | e  | max. t |  |      |
|---------|-------------|------------------|-----|--|----|----|----|--------|---|------|
| 8012590 | 1.16/1-HSP3 | 280              | 190 | 1.06/HSP3  | 36 | 32 | 19 | 3      | 8   | 9.3  |
| 8012670 | 1.16/2-HSP3 | 420              | 310 | 1.06/HSP3  | 36 | 32 | 22 | 3      | 8   | 11.3 |



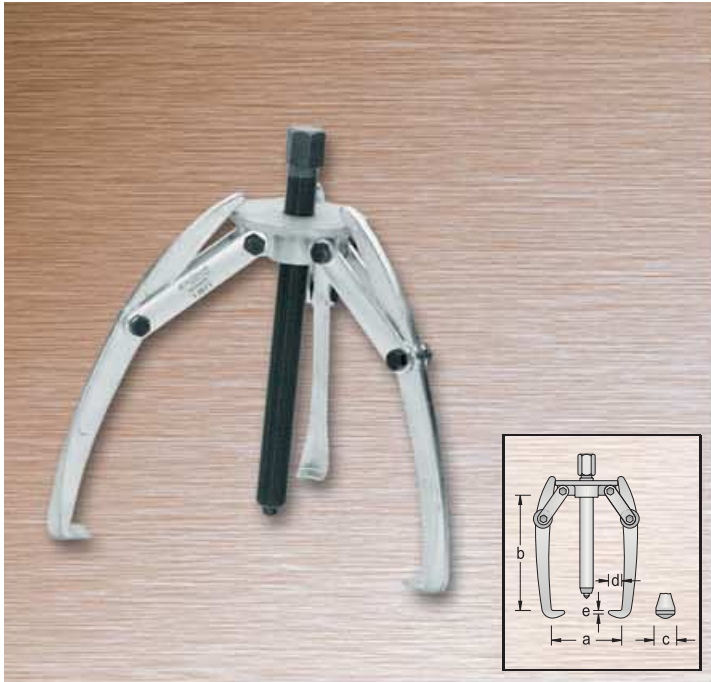

**1.17 Puller**  
**3-arm pattern**

Very strong type. Especially suitable for industrial purposes and for heavy agricultural and construction machines. Hooks grip automatically. Spindle may be exchanged for hydraulic pressure spindle (see table).

| Code    | No.    | a <sub>max</sub> | b   | ⌀         | Hydraulic spindle | ●mm | c  | d  | e | max. t | ⚙️   |
|---------|--------|------------------|-----|-----------|-------------------|-----|----|----|---|--------|------|
| 8007320 | 1.17/1 | 300              | 300 | G 1 x 360 | 1.06/HSP3         | 36  | 32 | 19 | 3 | 12     | 9.7  |
| 8007400 | 1.17/2 | 425              | 425 | G 1 x 500 | 1.06/HSP3         | 36  | 32 | 22 | 3 | 12     | 13.2 |

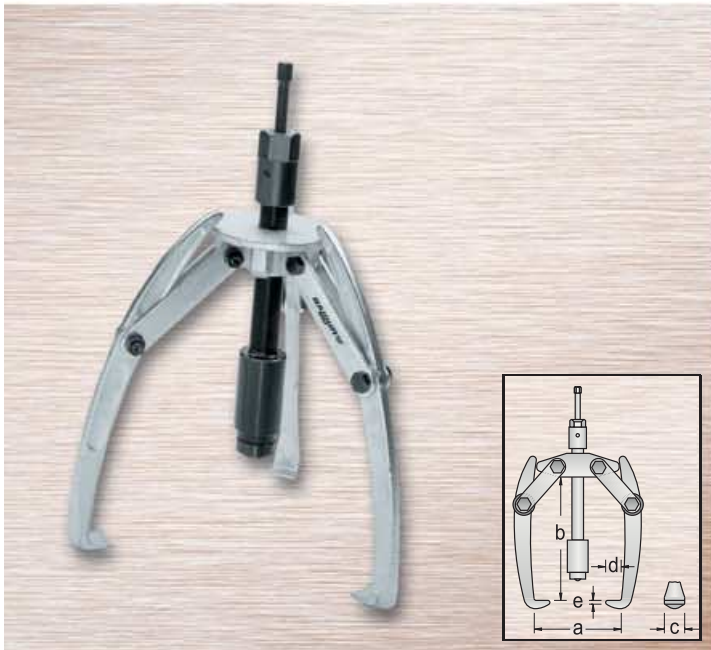

**1.17 HSP Puller**  
**hydraulic, 3-arm pattern**

Very strong type. Especially suitable for industrial purposes and for heavy agricultural and construction machines. Hooks grip automatically. With the hydraulic spindle, a controlled and safe pulling action is possible at all times.

| Code    | No.         | a <sub>max</sub> | b   | ⌀         | ●mm | c  | d  | e | max. t | ⚙️   |
|---------|-------------|------------------|-----|-----------|-----|----|----|---|--------|------|
| 8014290 | 1.17/1-HSP3 | 300              | 190 | 1.06/HSP3 | 36  | 32 | 19 | 3 | 12     | 11   |
| 8014370 | 1.17/2-HSP3 | 425              | 315 | 1.06/HSP3 | 36  | 32 | 22 | 3 | 12     | 14.5 |

9



**1.18 Puller ECO**  
**2-arm pattern**

The tried and tested range for economical bearing removal.

| Code    | No.    | a <sub>max</sub> | b   | ⌀              | ●mm | c  | d  | e   | max. t | ⚙️  |
|---------|--------|------------------|-----|----------------|-----|----|----|-----|--------|-----|
| 1464965 | 1.18/1 | 110              | 110 | M 14x1,5 x 163 | 17  | 17 | 18 | 5,0 | 2      | 1.0 |
| 1464973 | 1.18/2 | 160              | 140 | M 18x1,5 x 215 | 19  | 21 | 20 | 6,5 | 3      | 1.9 |
| 1464981 | 1.18/3 | 200              | 200 | G 1/2 x 282    | 22  | 22 | 22 | 7,5 | 5      | 2.3 |



### 1.19 Puller ECO

#### 3-arm pattern

The tried and tested range for economical bearing removal.

| Code    | No.    | a <sub>max</sub> | b   | — mm           | c  | d  | e  | max. t |       |
|---------|--------|------------------|-----|----------------|----|----|----|--------|-------|
| 1465007 | 1.19/1 | 110              | 110 | M 14x1,5 x 163 | 17 | 17 | 18 | 5,0    | 2 1.3 |
| 1465015 | 1.19/2 | 160              | 140 | M 18x1,5 x 215 | 19 | 21 | 20 | 6,5    | 3 2.5 |
| 1465023 | 1.19/3 | 200              | 200 | G 1/2 x 282    | 22 | 22 | 22 | 7,5    | 5 4.0 |

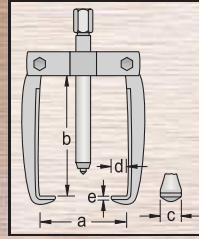

### 1.20 Puller

#### with clamping yoke

These pullers are mainly employed for removing car and truck steering arms. The clamping yoke presses the hooks firmly behind the part to be removed and prevents the puller from slipping out of position.

| Code    | No.    | a <sub>max</sub> | b   | — mm           | c  | d  | e  | max. t |         |
|---------|--------|------------------|-----|----------------|----|----|----|--------|---------|
| 8008050 | 1.20/1 | 90               | 85  | M 18x1,5 x 130 | 19 | 22 | 12 | 3,0    | 5,0 1.2 |
| 8008130 | 1.20/2 | 90               | 100 | M 18x1,5 x 130 | 19 | 24 | 15 | 3,0    | 5,0 1.8 |
| 8008210 | 1.20/3 | 150              | 140 | G 1/2 x 175    | 22 | 30 | 18 | 3,5    | 7,5 3.3 |

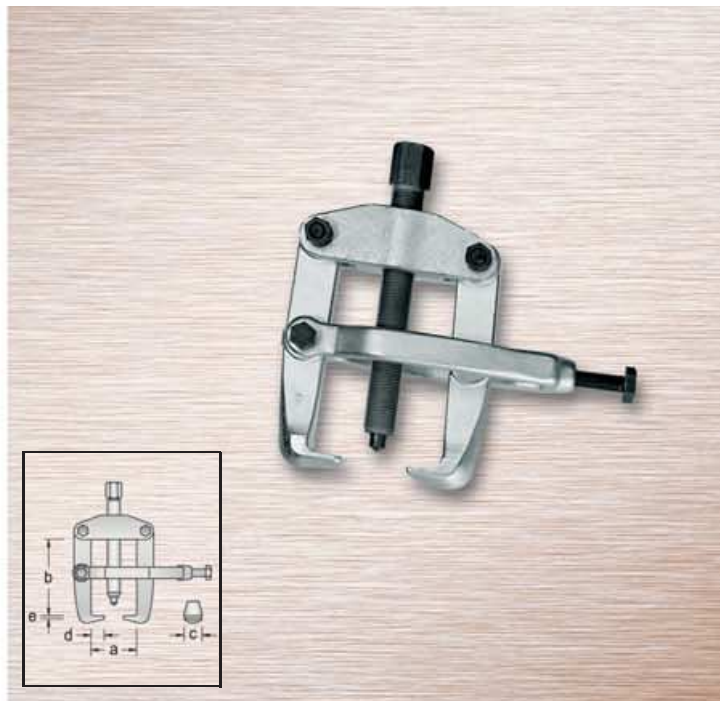
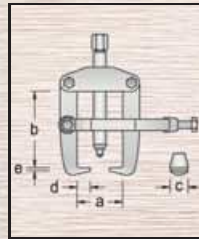

### 1.22 Puller

#### with clamping yoke

Due to its double-ended hooks, this tool is particularly suitable for separating and removing flush-seated parts, such as axle bearings, pinions, etc. Especially economical, this is a multi-functional tool to cover a range of sizes.

| Code    | No.    | a <sub>max</sub> | b   | — mm           | c  | d  | e  | max. t |         |
|---------|--------|------------------|-----|----------------|----|----|----|--------|---------|
| 8009020 | 1.22/1 | 110              | 170 | M 18x1,5 x 200 | 19 | 25 | 14 | 3,5    | 5,0 2.1 |
| 8009100 | 1.22/2 | 160              | 260 | G 1/2 x 350    | 22 | 25 | 14 | 3,5    | 7,5 4.1 |
| 8009290 | 1.22/3 | 160              | 325 | G 1/2 x 350    | 22 | 25 | 14 | 3,5    | 7,5 4.5 |

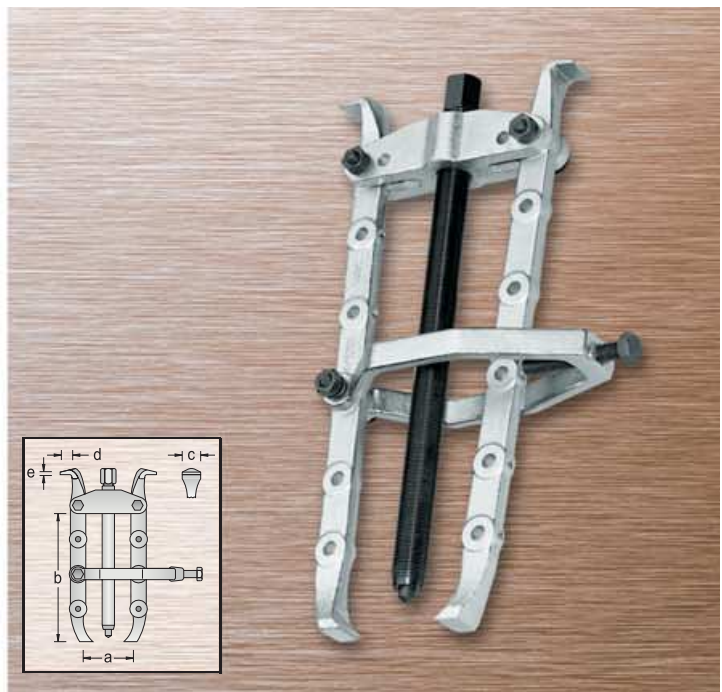
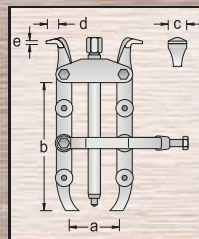

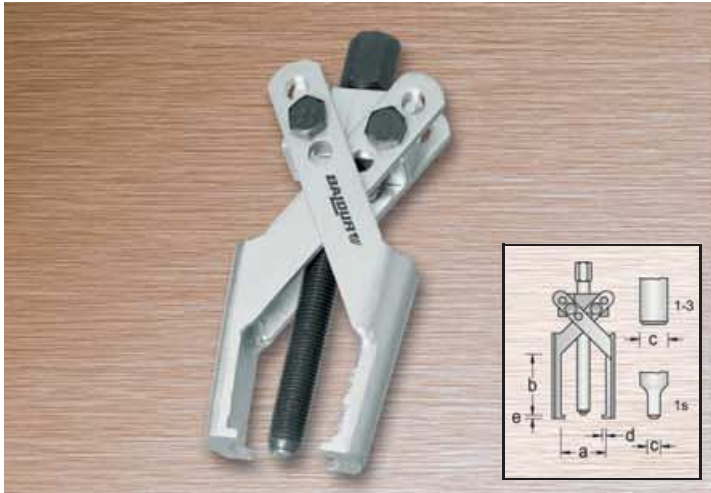

**1.23 Puller with slim hooks**

For removing bearings in confined spaces. The scissor-pattern hook design means that the hooks are pressed firmly onto the part during the removal procedure.

| Code    | No.     | a <sub>max</sub> | b   | —              | mm | c  | d   | e   | max. t | ↕   |
|---------|---------|------------------|-----|----------------|----|----|-----|-----|--------|-----|
| 8084580 | 1.23/1S | 80               | 85  | M 10 x 105     | 12 | 11 | 4,5 | 2,5 | 1,5    | 0.4 |
| 8084310 | 1.23/1  | 80               | 85  | M 10 x 105     | 12 | 23 | 4,5 | 2,5 | 2,0    | 0.4 |
| 8084660 | 1.23/2  | 120              | 120 | M 14x1,5 x 130 | 17 | 31 | 5,0 | 3,5 | 3,5    | 0.8 |
| 8084740 | 1.23/3  | 120              | 150 | M 14x1,5 x 205 | 17 | 31 | 5,0 | 3,5 | 3,5    | 1.0 |



**1.26 Nut splitter**

For splitting jammed or stripped nuts without damaging the bolt thread. Suitable for nuts up to property class 6.

| Code    | No.    | for nuts up to | —             | mm | ↕   |
|---------|--------|----------------|---------------|----|-----|
| 8009880 | 1.26/1 | SW 17, M 10    | M 14x1,5 x 37 | 17 | 0.2 |
| 8009610 | 1.26/2 | SW 24, M 16    | M 14x1,5 x 37 | 17 | 0.3 |
| 8010030 | 1.26/3 | SW 36, M 24    | M 22x1,5 x 70 | 24 | 1.0 |

**1.26/12 Nut splitter set**

In plastic wallet.

| Code    | No.     | Contents 1 each | ↕   |
|---------|---------|-----------------|-----|
| 8010110 | 1.26/12 | 1.26/1 1.26/2   | 0.5 |



**1.26 HYD Nut splitter hydraulic**

With strong chisel, additionally induction hardened at the cutting edge for breakage resistance. The chamfer at the chisel's edge improves the splitting effect and prevents breakage. With smooth chisel function. Channel walls rolled, thus mirror-smooth and wear resistant. No force necessary when turning back the chisel. For nuts up to property class 10.

| Code    | No.        | for nuts up to             | max. t | ↕   |
|---------|------------|----------------------------|--------|-----|
| 8009450 | 1.26/1 HYD | SW 7 - SW 22, M 4 - M 14   | 5      | 0.7 |
| 8009530 | 1.26/2 HYD | SW 22 - SW 36, M 14 - M 24 | 13     | 3.8 |



**1.28 Stud extractor**

For inserting and removing studs. These tools will reliably grip even extremely short stud ends. Slim pattern.

| Code    | No.    | ∅-Stud | mm | ↕   |
|---------|--------|--------|----|-----|
| 8010620 | 1.28/1 | 6-13   | 19 | 230 |
| 8010700 | 1.28/2 | 8-19   | 19 | 300 |
| 8010890 | 1.28/3 | 19-25  | 19 | 390 |



**1.28/4 Stud extractor**

For inserting and removing studs. These tools will reliably grip even extremely short stud ends.

| Code    | No.    | ∅-Stud | mm | ↕   |
|---------|--------|--------|----|-----|
| 1465031 | 1.28/4 | 5-26   | 19 | 390 |

### 1.29 Ball bearing extractor

These special extractors have been developed for removing ball bearings that are both on a shaft and in a housing. These hooks selected using the table are inserted into the ball race, evenly distributed in the outer ring according to the number of balls. The support rings supplied for the ball bearings to be removed are placed on the bearings' inner races. The bridge with spindle is then placed on the centering depression of the shaft and the spindle put under tension with the hooks.

| Code    | No.    | ←mm→       | mm | ↕    |
|---------|--------|------------|----|------|
| 8011000 | 1.29/1 | M 10 x 160 | 14 | 150  |
| 8011190 | 1.29/2 | M 12 x 195 | 14 | 280  |
| 8011270 | 1.29/3 | M 14 x 210 | 17 | 420  |
| 8011350 | 1.29/4 | M 18 x 230 | 19 | 750  |
| 8011430 | 1.29/5 | M 20 x 235 | 22 | 1100 |



Tool inventory at the professional fire brigade in Bochum.



### 1.29 Pulling hooks

set of 4 pieces

\* Support rings are used for pulling these bearings.

| Code    | No.     | ←mm→ | for bridge - for ball bearing No.                                      | ↕   |
|---------|---------|------|--|-----|
| 8011510 | 1.29/10 | 145  | 1.29/1 - 6000 6001 6002  | 80  |
| 8011780 | 1.29/15 | 145  | 1.29/1 - 6003 6004 6005 6200 6201 6202                                 | 100 |
| 8011860 | 1.29/20 | 177  | 1.29/2 - 6006 6203   | 200 |
| 8011940 | 1.29/25 | 177  | 1.29/2 - 6007 6008 6009 6010<br>6204 6205 6300 6301 6302               | 200 |
| 8012080 | 1.29/30 | 185  | 1.29/2 - 6303 6304<br>1.29/3 - 6011 6012                               | 300 |
| 8012160 | 1.29/35 | 187  | 1.29/3 - 6206 6207 6208 6305   | 400 |
| 8012240 | 1.29/40 | 235  | 1.29/4 - 6209 6210   | 600 |
| 8110250 | 1.29/45 | 236  | 1.29/4 - 6211 6212 6308* 6404 6405<br>1.29/5 - 6309* 6310* 6311* 6406* | 800 |



### 1.29 K Ball bearing extractor set

In sheet metal case, dimensions: 285 x 190 x 75 mm.

| Code    | No.     | Contents   | ↕   |
|---------|---------|--|-----|
| 8110330 | 1.29/1K | 3 hubs with spindle 1.29/1 - 1.29/3<br>6 sets hooks 1.29/10 - 1.29/35<br>1 plug-in handle 1.29/0                     | 4.7 |
| 8012320 | 1.29/3K | 5 hubs with spindle 1.29/1 - 1.29/5<br>6 sets hooks 1.29/10 - 1.29/45<br>1 plug-in handle 1.29/0 and 4 support rings | 8.0 |





### 1.92 Ball bearing extractor PLUS

Using the new BALDUR ball bearing extractor, the removal of shaft-mounted ball bearings in a housing is now possible without any problems. Due to its great degree of functionality combined with the simplified handling, this novel design makes a PLUS in effectiveness and productivity possible. This tool is distinguished by its extreme user-friendliness. The hooks are fixed in the slot.

The self-locking arrangement means that the force applied is 100% utilised. Secure at all times against slipping off - and a straight pulling force for precise working.

Suitable for more than 40 standard ball bearings up to 6311.

- \* with supporting ring 6309
- \*\* with supporting ring 6310
- \*\*\* with supporting ring 6311

| Code    | No.     | Bearing                           | Hook | Head size |
|---------|---------|-----------------------------------|------|-----------|
|         |         | 6000                              | 10   | 1-7       |
|         |         | 6001                              | 10   | 1-4       |
|         |         | 6002                              | 10   | 1-3       |
|         |         | 6003                              | 10   | 1-4       |
|         |         | 6200                              | 10   | 1-4       |
|         |         | 6201                              | 20   | 1-7       |
|         |         | 6202                              | 20   | 1-4       |
|         |         | 6203                              | 20   | 1-4       |
|         |         | 6004                              | 20   | 1-3       |
|         |         | 6005                              | 20   | 1-3       |
|         |         | 6006                              | 20   | 1-3       |
| 1553534 | 1.92/1  | 6300                              | 30   | 1-3       |
|         |         | 6301                              | 30   | 1-3       |
|         |         | 6302                              | 30   | 1-7       |
|         |         | 6007                              | 40   | 1-3       |
|         |         | 6008                              | 40   | 1-3       |
|         |         | 6204                              | 40   | 1-4       |
|         |         | 6009                              | 40   | 1-3       |
|         |         | 6010                              | 40   | 1-3       |
|         |         | 6205                              | 40   | 1-3       |
|         |         | 6303                              | 40   | 1-7       |
|         |         | 6304                              | 40   | 1-7       |
|         |         | 6011                              | 50   | 2-3       |
|         |         | 6012                              | 50   | 2-3       |
|         |         | 6206                              | 50   | 2-3       |
|         |         | 6207                              | 50   | 2-3       |
|         |         | 6305                              | 50   | 2-7       |
|         |         | 6403                              | 60   | 2-3       |
|         |         | 6306                              | 60   | 2-4       |
|         |         | 6307                              | 60   | 2-4       |
|         |         | 6208                              | 60   | 2-3       |
|         |         | 6209                              | 60   | 2-3       |
| 1553542 | 1.92/2  | 6210                              | 60   | 2-3       |
|         |         | 6211                              | 60   | 2-3       |
|         |         | 6407*                             | 60   | 2-3       |
|         |         | 6404                              | 70   | 2-7       |
|         |         | 6405                              | 70   | 2-7       |
|         |         | 6406                              | 70   | 2-7       |
|         |         | 6308                              | 70   | 2-4       |
|         |         | 6309                              | 70   | 2-4       |
|         |         | 6212                              | 70   | 2-3       |
|         |         | 6310**                            | 70   | 2-4       |
|         |         | 6311***                           | 70   | 2-4       |
| 1553550 | 1.92/12 | Contents of set 1.92/1 and 1.92/2 |      |           |



### 1.30 Internal extractor

For extremely-tightly-packed ball bearings, bearing races, bushings, and oil seals®.

**Operation:**

The internal extractor is inserted into the bearing and the spindle screwed in. The sharp turned-out shoulders of the pulling shell jaws will press outwards behind the part to be extracted. The counter-support brace is then added. Both feet must be aligned parallel to the spindle to ensure rigidity.

| Code    | No.     | M        | mm     | mm | mm   |
|---------|---------|----------|--------|----|------|
| 8012750 | 1.30/0  | M 10     | 5-8    | 10 | 150  |
| 8012830 | 1.30/1  | M 10     | 8-12   | 10 | 160  |
| 8012910 | 1.30/2  | M 10     | 12-15  | 10 | 170  |
| 8013130 | 1.30/3  | M 10     | 15-19  | 14 | 170  |
| 8013480 | 1.30/4  | M 10     | 19-25  | 14 | 200  |
| 8013560 | 1.30/4A | M 10     | 25-30  | 14 | 300  |
| 8013640 | 1.30/5  | M 10     | 30-35  | 14 | 350  |
| 8013720 | 1.30/6  | M 14x1,5 | 35-45  | 17 | 650  |
| 8013800 | 1.30/7  | M 14x1,5 | 45-55  | 17 | 800  |
| 8013990 | 1.30/8  | M 14x1,5 | 55-70  | 19 | 1400 |
| 8014020 | 1.30/9  | M 14x1,5 | 70-100 | 27 | 2900 |



### 1.30 N Internal extractor with reinforced shoulder

Especially suitable for the safe and trouble-free extraction of needle roller bearings, ball bearings and brass sleeves from crankshafts.

**Note:**

The shoulder of the shell jaw must be applied behind the bearing.

| Code    | No.     | M    | mm    | mm | mm  |
|---------|---------|------|-------|----|-----|
| 8013050 | 1.30/2N | M 10 | 12-14 | 10 | 170 |
| 8013210 | 1.30/3N | M 10 | 14-19 | 14 | 170 |



### 1.30/10 Internal extractor

Suitable for removing large ball bearings and bearing outer races.

**Operation:**

The extraction jaws are spread by turning the nut. The newly-developed spreading system enables a simple, step-free and time-saving adjustment to the desired diameter to be made. The sharp-edged sections of the extraction jaws seat flush beneath when spread.

| Code    | No.     | M      | mm     | mm | mm   |
|---------|---------|--------|--------|----|------|
| 8014100 | 1.30/10 | G 1/2" | 60-160 | 36 | 2450 |



### 1.35 Impact bearing puller

Suited for the removal of small ball bearings since there is often not enough room for support braces.

| Code    | No.    | for internal extractor with adaptor | M          | mm   | mm      |
|---------|--------|-------------------------------------|------------|------|---------|
| 8016070 | 1.35/1 | 1.30/1 - 1.30/2                     | -          | M 10 | 17 550  |
| 8039010 | 1.35/2 | 1.30/0 - 1.30/7                     | M 14 x 1,5 | M 10 | 24 3200 |





### 1.36 Support brace

For internal extractors Nos. 1.30/0 – 1.30/9.

#### Operation:

The support brace is placed on the housing and the spindle screwed onto the spindle of the internal extractor. The toggle is held firmly, and the bearing extracted by tightening the nut.

| Code    | No.    | for internal extractor | M        | mm |      |
|---------|--------|------------------------|----------|----|------|
| 8016580 | 1.36/1 | 1.30/1 - 1.30/5        | M 10     | 27 | 600  |
| 8016660 | 1.36/2 | 1.30/6 - 1.30/8        | M 14x1,5 | 32 | 1400 |
| 8016740 | 1.36/3 | 1.30/9                 | M 14x1,5 | 32 | 3000 |

### 1.36/4 Support brace

For internal extractor No. 1.30/10.

Operation see No. 1.36

| Code    | No.    | for internal extractor | M      | mm |      |
|---------|--------|------------------------|--------|----|------|
| 8016820 | 1.36/4 | 1.30/10                | G 1/2" | 36 | 7700 |



### 1.31 Internal extractor set

The handy sheet metal case contains the most used extractor sizes for the removal of ball bearings, bearing races, bushings, oil seals®, etc.

| Code    | No.     | Contents  |      |
|---------|---------|---|------|
| 8014450 | 1.31/0N | 4 internal extractors 12-30 mm 1.30/2 -3 -4 -4A<br>1 support brace 1.36/1   | 2.4  |
| 8014530 | 1.31/0  | 4 internal extractors 12-30 mm 1.30/2N -3N -4 -4A<br>1 support brace 1.36/1 | 2.4  |
| 8014610 | 1.31/1  | 6 internal extractors 12-46 mm 1.30/2 - 6<br>2 support braces 1.36/1 - 2    | 5.9  |
| 8014880 | 1.31/2  | 8 internal extractors 12-70 mm 1.30/2 - 8<br>2 support braces 1.36/1 - 2    | 10.0 |



### 1.32 Set of internal and external extractors

In a handy sheet metal case. Sets comprise internal extractors, support braces, pulling chucks, external extractors and stud extractors.

| Code    | No.    | Contents  |      |
|---------|--------|---|------|
| 8015260 | 1.32/1 | 6 internal extractors 12-46 mm 1.30/2 - 6<br>2 support braces 1.36/1 - 2<br>1 pulling chuck 1.44<br>1 battery-terminal puller 1.12/02<br>1 puller, 2-arm pattern 1.06/1                                 | 10.0 |
| 8015340 | 1.32/2 | 8 internal extractors 12-70 mm 1.30/2 - 8<br>2 support braces 1.36/1 - 2<br>1 pulling chuck 1.44<br>1 battery-terminal puller 1.12/02<br>2 pullers, 2-arm pattern 1.06/1 - 2<br>1 stud extractor 1.28/1 | 19.0 |

### 1.37 Cylinder liner puller complete with support brace

Wet heavy-vehicle (e.g. Daimler Benz, MAN) cylinder liners, automobile and stationary-engine liners, and other parts may be extracted using this puller.

**Operation:**

The spindle of the support brace is screwed into the clamping nut of the puller, and the puller inserted into the liner. The support brace is placed on to the cylinder block. Due to the newly-developed spreading system, when the spindle is turned, all three jaws spread quickly and without difficulty, until they are firmly seated beneath the edge of the liner. Then the nut of the support brace is tightened.



| Code    | No.    | M      | mm     | mm |      |
|---------|--------|--------|--------|----|------|
| 8017200 | 1.37/2 | G 1/2" | 60-160 | 36 | 6800 |

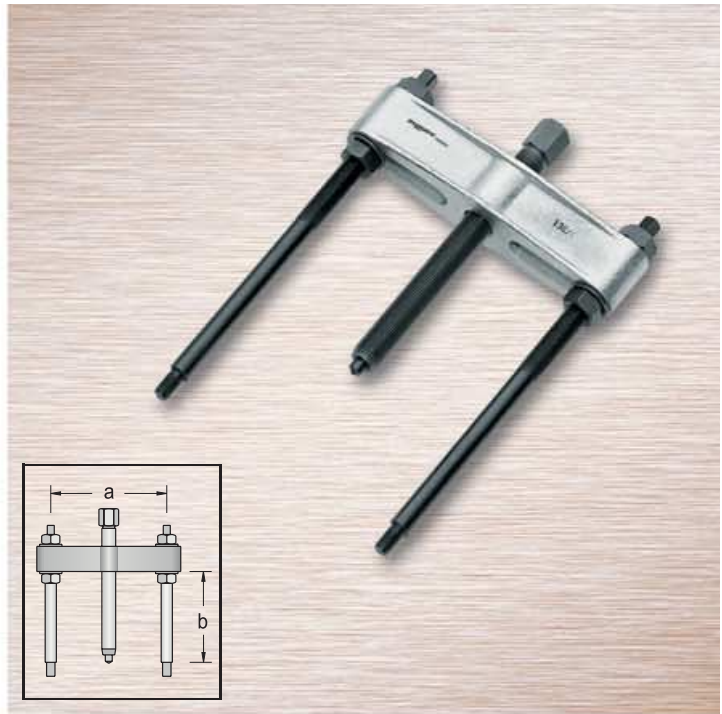

### 1.38 Separator puller

These separator pullers are used together with the bearing separators No. 1.40. The tension bolts are screwed into the threaded holes in the bearing separators.

| Code    | No.    | for separator | a       | b   | mm          | mm | M / M top           | Hydraulic spindle |      |
|---------|--------|---------------|---------|-----|-------------|----|---------------------|-------------------|------|
| 8017550 | 1.38/0 | 1.40/0        | 40-120  | 160 | M 14 x 120  | 17 | M 10 / M 12x1,5     |                   | 1.0  |
| 8017630 | 1.38/1 | 1.40/1        | 60-165  | 230 | M 18 x 170  | 19 | M 10 / M 14x1,5     |                   | 2.4  |
| 8017710 | 1.38/2 | 1.40/2        | 70-215  | 250 | G 1/2 x 210 | 22 | M 14x1,5 / M 16x1,5 | 1.06/HSP1         | 3.8  |
| 8017980 | 1.38/3 | 1.40/3        | 90-300  | 270 | G 3/4 x 280 | 27 | M 18x1,5 / M 20x1,5 | 1.06/HSP2         | 7.2  |
| 8018010 | 1.38/4 | 1.40/4        | 125-380 | 350 | G 1 x 310   | 36 | M 22x1,5 / M 24x1,5 | 1.06/HSP3         | 11.3 |
| 8018280 | 1.38/5 | 1.40/5        | 140-440 | 400 | G 1 x 360   | 36 | M 24x1,5 / M 26x1,5 | 1.06/HSP3         | 16.3 |

### 1.38 V Extension rod

For separator puller No. 1.38.

| Code    | No.     | for separator | M          | mm  |     |
|---------|---------|---------------|------------|-----|-----|
| 8018440 | 1.38/AV | 1.38/0 1.38/1 | M 10       | 100 | 0.2 |
| 8018520 | 1.38/CV | 1.38/2        | M 14 x 1,5 | 100 | 0.5 |
| 8018600 | 1.38/DV | 1.38/3        | M 18 x 1,5 | 100 | 0.6 |
| 8018790 | 1.38/EV | 1.38/4        | M 22 x 1,5 | 200 | 2.1 |
| 8018870 | 1.38/FV | 1.38/5        | M 24 x 1,5 | 200 | 2.7 |



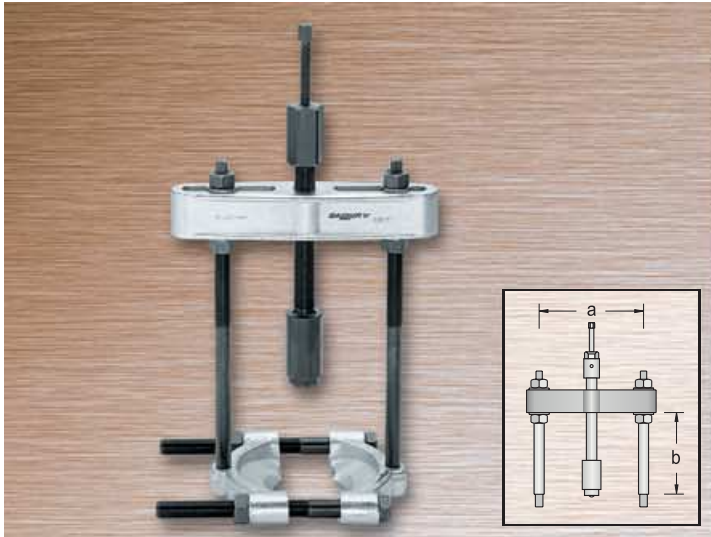

**1.38 HSP Separator puller**  
hydraulic, for separating blades

These pullers are used together with the separating blades No. 1.40. The tension bolts are screwed into the threaded bores of the separating blades.

| Code    | No.         | for separator | a       | b   |            |      |
|---------|-------------|---------------|---------|-----|------------|------|
| 8014960 | 1.38/2-HSP1 | 1.40/2        | 70-215  | 175 | M 14 x 1,5 | 4.0  |
| 8015180 | 1.38/3-HSP2 | 1.40/3        | 90-300  | 195 | M 18 x 1,5 | 6.8  |
| 8015420 | 1.38/4-HSP3 | 1.40/4        | 125-380 | 240 | M 22 x 1,5 | 11.8 |
| 8015500 | 1.38/5-HSP3 | 1.40/5        | 140-440 | 290 | M 24 x 1,5 | 16.6 |



**1.40 Bearing separator**

For removing taper roller and ball bearings, inner bearing races, and other tightly-seated or thin-walled parts.

**Operation:**

To remove tightly-seated parts, the sharp edges of the separator blades are pressed behind the part and it is then withdrawn using the correct puller No. 1.38. To avoid damage to delicate parts, the flat surfaces of the separator blades are used. This produces a large support surface that prevents deformation.

| Code    | No.    | for puller |            | mm     |      |
|---------|--------|------------|------------|--------|------|
| 8019680 | 1.40/0 | 1.38/0     | M 10       | 5-60   | 0.4  |
| 8019760 | 1.40/1 | 1.38/1     | M 10       | 12-75  | 1.0  |
| 8019840 | 1.40/2 | 1.38/2     | M 14 x 1,5 | 22-115 | 2.3  |
| 8019920 | 1.40/3 | 1.38/3     | M 18 x 1,5 | 30-155 | 4.4  |
| 8020180 | 1.40/4 | 1.38/4     | M 22 x 1,5 | 30-200 | 8.9  |
| 8020260 | 1.40/5 | 1.38/5     | M 24 x 1,5 | 30-250 | 15.3 |



**1.41 Separator and puller set**

Set in sheet metal case, comprising separator, puller, and extension rods. Dimensions: 420 x 320 x 80 mm.

| Code    | No.    | Contents              |      |
|---------|--------|-----------------------|------|
| 8109750 | 1.41/0 | 1.38/0 1.38/AV 1.40/0 | 2.8  |
| 8109830 | 1.41/1 | 1.38/1 1.38/AV 1.40/1 | 4.1  |
| 8109910 | 1.41/2 | 1.38/2 1.38/CV 1.40/2 | 9.1  |
| 8110090 | 1.41/3 | 1.38/3 1.38/DV 1.40/3 | 16.1 |
| 8110170 | 1.41/4 | 1.38/4 1.38/EV 1.40/4 | 28.6 |

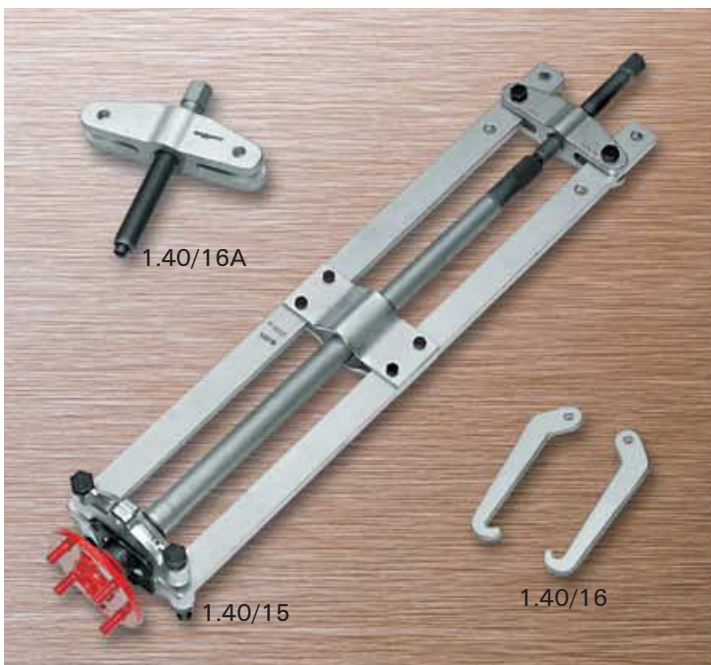

**1.40/15 Drive shaft bearing puller**

**Operation:**

The separator blades are placed evenly behind the bearing and the pulling arms aligned parallel to the axle and spindle.

| Code    | No.     | Aperture | mm  |             | mm |      |
|---------|---------|----------|-----|-------------|----|------|
| 8010380 | 1.40/15 | 45-75    | 750 | G 1/2 x 160 | 22 | 11.8 |

**1.40/16 Set of hooks**

**2 pieces**

These hooks, together with the crossbeam and separator blades of No. 1.40/15, are used for mounting drive-shaft bearings.

**Operation:**

The separator blades are placed with the flat side behind the bearing, and the hooks inserted behind the clamping bolt of the separator blades. When the spindle is tightened, the bearing is pulled against the axle flange.

| Code    | No.      | Description                 |     |
|---------|----------|-----------------------------|-----|
| 8010460 | 1.40/16  | 1 pair hooks as illustrated | 1.4 |
| 8010540 | 1.40/16A | Crossbeam with spindle      | 2.2 |



### 1.44 Pulling chuck

For removing the inner races of dynamos, magnetos, motors, and other machine parts. Simple operation by tightening the cap nut.

| Code    | No.    | Clamping range mm | Clamping reach mm |  |
|---------|--------|-------------------|-------------------|---|
| 8022040 | 1.44/1 | 5-32              | 125               | 1.4   |



Forging of the heavy-duty puller crossbeams in the BALDUR works in Remscheid.



### 1.50 Hydraulic pump and cylinder set

This hydraulic set, consisting of hand pump 1.50/1 and hydraulic cylinder 1.51, is suitable for pressing, straightening, lifting, bending, and pulling.

| Code    | No.     | consisting of:   |  |
|---------|---------|--|---|
| 8110410 | 1.50/10 | Hydraulic hand pump 1.50/1<br>Hydraulic cylinder 1.51/10 | 11.0  |
| 8110680 | 1.50/11 | Hydraulic hand pump 1.50/1<br>Hydraulic cylinder 1.51/11 | 13.0  |



### 1.50/1 Hydraulic hand pump

Supplied complete with 1.50 m high-pressure hose, to fit hydraulic cylinder 1.51.

| Code    | No.    | for hydraulic cylinder |  |
|---------|--------|------------------------|---|
| 8022710 | 1.50/1 | 1.51/10 1.51/11        | 7.0   |



### 1.51 Hydraulic cylinder

| Code    | No.     | Stroke height mm | max. t |  |
|---------|---------|------------------|--------|---|
| 8023440 | 1.51/10 | 140              | 10     | 4.0   |
| 8110760 | 1.51/11 | 200              | 10     | 6.0   |



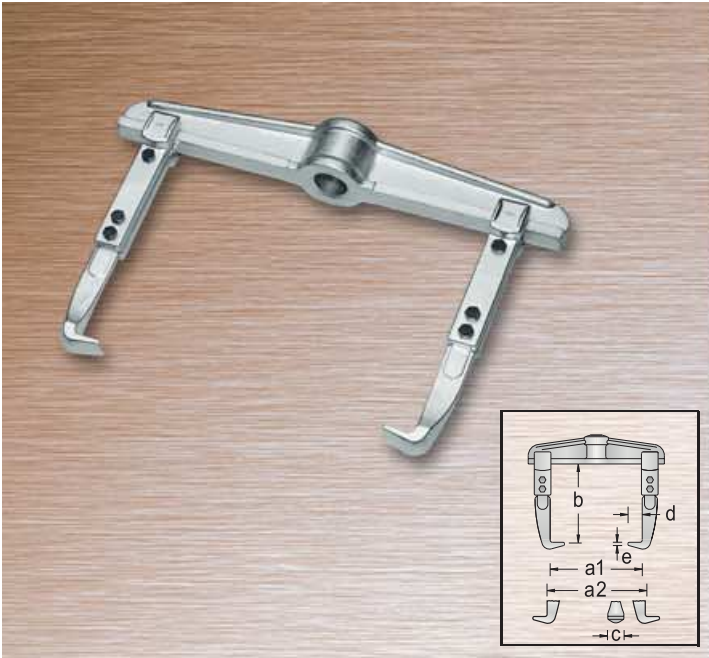

**1.06 Puller  
for hydraulic implement 1.50**

For the fast and damage-free removal of pulleys, wheels, ball bearings, etc. Robust pattern, designed for rigidity and heavy duty use. By reversing the hooks, this tool may be used as an internal or external puller. The reach may be increased both by using pulling hooks in special lengths, and by using extensions.

| Code    | No.     | a <sub>1</sub> | a <sub>2 min</sub> | a <sub>2 max</sub> | b   | c  | d  | e    | max. t |      |
|---------|---------|----------------|--------------------|--------------------|-----|----|----|------|--------|------|
| 8112620 | 1.06/40 | 520            | 185                | 600                | 200 | 36 | 28 | 6,5  | 10     | 11.0 |
| 8113000 | 1.06/50 | 640            | 230                | 715                | 225 | 50 | 33 | 10,0 | 18     | 24.0 |

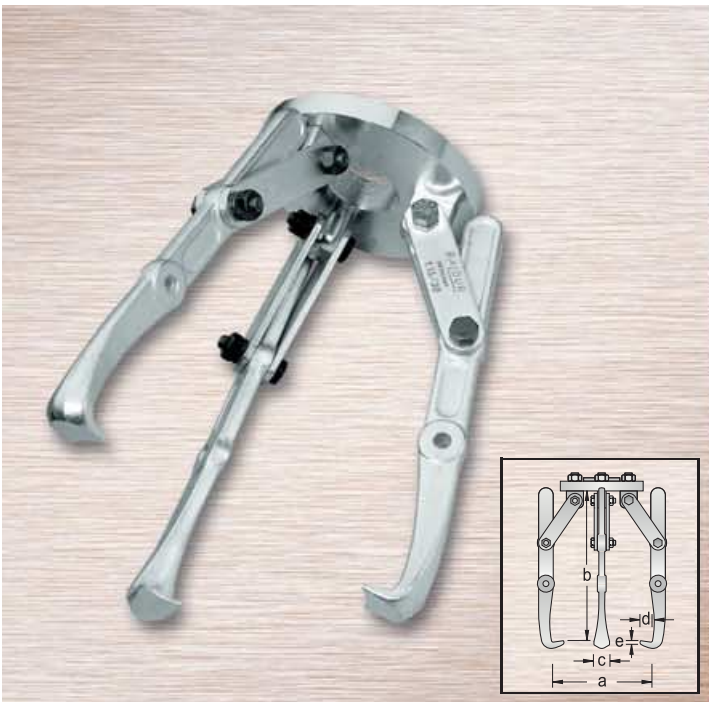

**1.15 H Puller  
for hydraulic implement 1.50**

Heavy duty pattern for the removal of gear wheels, spoked wheels, pulleys, etc. The hook tips grip automatically. The hooks may be moved to use this tool as a 2-arm puller. The adjustable reach means that this puller is very versatile.

| Code    | No.     | a <sub>max</sub> | b   | c  | d  | e   | max. t |     |
|---------|---------|------------------|-----|----|----|-----|--------|-----|
| 8006860 | 1.15/30 | 250              | 260 | 32 | 18 | 3,5 | 12     | 9.0 |
| 8109590 | 1.15/40 | 280              | 390 | 32 | 20 | 3,5 | 12     | 9.5 |



**1.17 H Puller  
for hydraulic implement 1.50**

Heavy duty pattern for the removal of gear wheels, spoked wheels, pulleys, etc. The hook tips grip automatically.

| Code    | No.     | a <sub>max</sub> | b   | c  | d  | e   | max. t |      |
|---------|---------|------------------|-----|----|----|-----|--------|------|
| 8007590 | 1.17/10 | 300              | 300 | 36 | 19 | 3,5 | 12     | 11.4 |
| 8109670 | 1.17/20 | 425              | 425 | 36 | 22 | 3,5 | 12     | 12.3 |

### 1.55 Hydraulic press

This piece of auxiliary equipment considerably increases the capability of the standard pressure spindle.

**Operation:**

With pressure released, the press is placed between the pressure spindle and the end of the shaft. The pressure spindle is then tightened firmly. Care must be taken that the centreline of the shaft, the hydraulic press, and the pressure spindle are exactly in alignment. Then the hydraulic spindle is screwed inwards.

Important note: Release the hydraulic press after use.

| Code    | No.    | Stroke height mm | Installed height mm | max. t |     |
|---------|--------|------------------|---------------------|--------|-----|
| 8024090 | 1.55/1 | 10               | 75                  | 8      | 0.7 |
| 8024170 | 1.55/2 | 15               | 90                  | 15     | 1.3 |

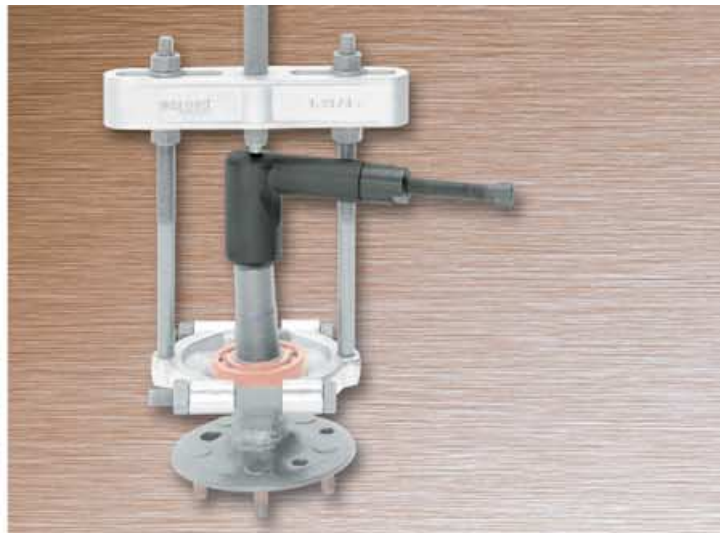

### 1.60 Wheel-hub puller

For cars and trucks with wheel stud circles up to 225 mm. Easy to use. With wheel stud protection using rotating nut apertures that always lie flat to the hub. Spindle may be exchanged for hydraulic pressure spindle (see table).

| Code    | No.    | No. of hooks |             | Hydraulic spindle |     |
|---------|--------|--------------|-------------|-------------------|-----|
| 8024840 | 1.60/3 | 3            | G 3/4 x 200 | 1.06/HSP2         | 4.0 |
| 8110840 | 1.60/5 | 4            | G 3/4 x 200 | 1.06/HSP2         | 4.5 |
| 8024920 | 1.60/4 | 5            | G 3/4 x 200 | 1.06/HSP2         | 5.0 |
| 8110920 | 1.60/H | 1            | spare hook  |                   | 0.5 |

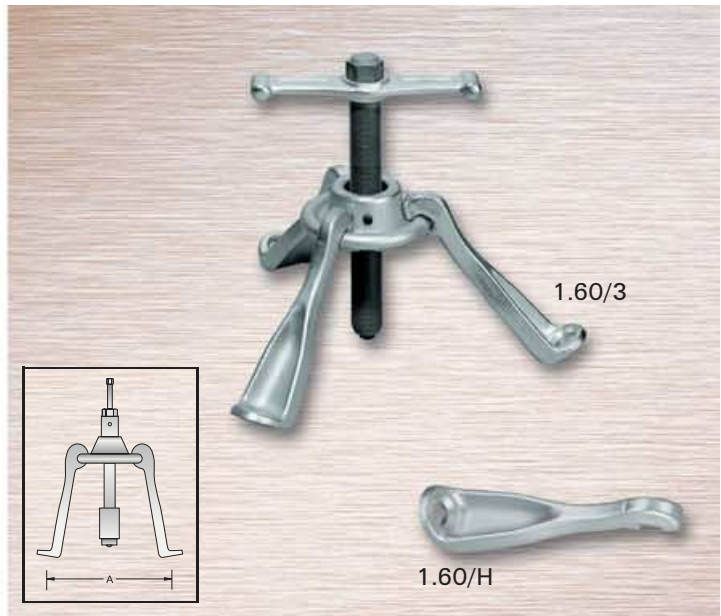

### 1.60 HSP Wheel-hub puller hydraulic

For cars and trucks with wheel stud circles up to 225 mm. Easy to use. With wheel stud protection using rotating nut apertures that always lie flat to the hub.

| Code    | No.         | No. of hooks |  | Hydraulic spindle |     |
|---------|-------------|--------------|--|-------------------|-----|
| 8015690 | 1.60/3-HSP2 | 3            |  | 1.06/HSP2         | 4.6 |
| 8015770 | 1.60/4-HSP2 | 4            |  | 1.06/HSP2         | 5.1 |
| 8015850 | 1.60/5-HSP2 | 5            |  | 1.06/HSP2         | 5.6 |



### 1.61 Wheel-hub puller

For cars and trucks with wheel stud circles up to 250 mm. Simple use. Just place the plate with the spindle on the centre-marking of the axle and fold back the hooks onto the plate. With swivelling nut holders always lying flat on the hub to prevent wheel-stud damage. Spindle may be exchanged for hydraulic pressure spindle (see table).

| Code    | No.    | No. of hooks |             | Hydraulic spindle |     |
|---------|--------|--------------|-------------|-------------------|-----|
| 8111060 | 1.61/3 | 3            | G 3/4 x 200 | 1.06/HSP2         | 5.0 |
| 8111140 | 1.61/4 | 4            | G 3/4 x 200 | 1.06/HSP2         | 5.6 |
| 8025300 | 1.61/5 | 5            | G 3/4 x 200 | 1.06/HSP2         | 6.2 |
| 8111220 | 1.61/H | 1            | spare hook  |                   | 0.6 |

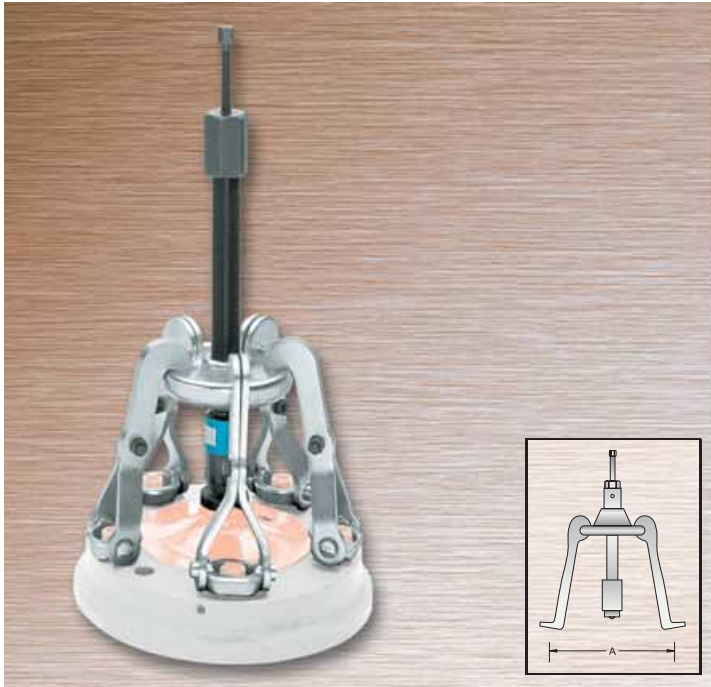

**1.61 HSP Wheel-hub puller hydraulic**

For cars and trucks with wheel stud circles up to 250 mm. Easy to use. With wheel stud protection using rotating nut apertures that always lie flat to the hub.

| Code    | No.         | No. of hooks | Hydraulic spindle |     |
|---------|-------------|--------------|-------------------|-----|
| 8015930 | 1.61/3-HSP2 | 3            | 1.06/HSP2         | 5.6 |
| 8016150 | 1.61/4-HSP2 | 4            | 1.06/HSP2         | 6.2 |
| 8016230 | 1.61/5-HSP2 | 5            | 1.06/HSP2         | 6.8 |



**1.62 Wheel-hub puller**

For trucks with wheel stud circles up to 350 mm. Easy to use. With wheel stud protection using rotating nut apertures that always lie flat to the hub. This tool may also be used with the hydraulic aid without requiring a reduction bushing.

| Code    | No.    | No. of hooks | A          | Hydraulic spindle |      |
|---------|--------|--------------|------------|-------------------|------|
| 8026030 | 1.62/8 | 8            | G 1 x 310  | 1.06/HSP3         | 10.5 |
| 8111220 | 1.61/H | 1            | spare hook |                   | 0.6  |

**1.62 HSP Wheel-hub puller hydraulic**

For trucks with wheel stud circles up to 350 mm. Easy to use. With wheel stud protection using rotating nut apertures that always lie flat to the hub.

| Code    | No.         | No. of hooks |           |      |
|---------|-------------|--------------|-----------|------|
| 8016310 | 1.62/8-HSP3 | 8            | 1.06/HSP3 | 11.9 |



**1.64 Drive shaft puller**

Suitable for drive shafts with 4 or 5 apertures. For wheel stud circles 100-180 mm.

**Operation:**

The puller is attached to the drive shaft flange using the nuts of the wheel bolts. By striking the spindle head with the sliding hammer, the shaft may be removed easily and without damage.

| Code    | No.    |          |     |
|---------|--------|----------|-----|
| 8026700 | 1.64/1 | max. M14 | 3.8 |



**1.65 Pulling flange**

The flange possesses slots for hole pitches of 180, 120, and 90 degrees. Additional holes may be drilled to render the flange suitable for other pitches and aperture diameters. A very sturdy model for heavy parts and the highest requirements.

Spindle may be exchanged for hydraulic pressure spindle (see table).

| Code    | No.    | Stud $\varnothing$ mm |           | Hydraulic spindle |      |
|---------|--------|-----------------------|-----------|-------------------|------|
| 8027000 | 1.65/1 | up to 16              | G 1 x 270 | 1.06/HSP3         | 16.3 |

### 1.66 Pulling flange

For wheels and discs with tapped holes up to M10. The flange is fitted with slots for hole pitches of 180 and 120 degrees, and using one pair each of long and short hooks and a protective cap for the thread of the steering column, this tool is suitable as a steering wheel puller.

| Code    | No.     | Stud $\varnothing$ mm                         |            | mm |     |
|---------|---------|---|------------|----|-----|
| 8027510 | 1.66/1  | up to 10                                      | M 12 x 110 | 14 | 0.7 |
| 8027780 | 1.66/11 | with hooks in length 85 + 135 mm, 1 pair each | M 12 x 110 | 14 | 1.0 |



### 1.67 Steering-wheel puller

Steering-wheel puller for cars. The puller includes one pair of short hooks, one pair of long hooks, and a protective cap for the thread of the steering column.

| Code    | No.    | Clamping reach | Hook length up to | mm             |        |
|---------|--------|----------------|-------------------|----------------|--------|
| 8028240 | 1.67/1 | 35-90          | 135               | M 14x1,5 x 150 | 17 0.6 |



### 1.68 Steering-wheel puller

Steering-wheel puller featuring one pulling ring each with 100 mm and 150 mm diameter for 3-spoke and 4-spoke steering wheels. To protect the steering-wheels, the pulling rings are fitted with sliding rubber sleeves.

| Code    | No.    | Hook length mm | mm         |        |
|---------|--------|----------------|------------|--------|
| 8028750 | 1.68/1 | 120            | M 18 x 170 | 19 2.0 |



### 1.70 Dismantling and assembly fork

The wedge-shaped fork end makes the fast removal of track rod and push rod ends, steering arms, and other steering parts possible. Also suitable for removing shock absorbers and other separating and dismantling work. The forks are suitable for use in the most confined spaces. Hammer blows on the handle ends are used to separate the parts.

| Code    | No.    | A mm | B mm | C mm |     |
|---------|--------|------|------|------|-----|
| 8029210 | 1.70/1 | 18   | 340  | 80   | 0.8 |
| 8029480 | 1.70/2 | 23   | 340  | 80   | 0.8 |
| 8029560 | 1.70/3 | 29   | 350  | 90   | 1.0 |
| 8029640 | 1.70/4 | 40   | 350  | 90   | 1.1 |
| 8085040 | 1.70/5 | 45   | 355  | 95   | 1.2 |





**1.72 Ball joint puller**

For the simple and damage-free removal of ball pins on track rods and push rods.

| Code    | No.    | a  | b  | c  |               | mm |     |
|---------|--------|----|----|----|---------------|----|-----|
| 8030300 | 1.72/1 | 18 | 35 | 40 | M 14x1,5 x 50 | 17 | 0.3 |
| 8030490 | 1.72/2 | 23 | 45 | 50 | M 14x1,5 x 50 | 17 | 0.5 |
| 8030570 | 1.72/3 | 27 | 56 | 60 | M 18x1,5 x 80 | 19 | 0.7 |
| 8030650 | 1.72/4 | 37 | 78 | 75 | G 1/2 x 110   | 22 | 1.5 |



**1.73 Universal ball joint puller**

For removing ball joints on cars and trucks.

| Code    | No.    | mm | Clamping height | Fork depth |     |
|---------|--------|----|-----------------|------------|-----|
| 8030810 | 1.73/1 | 23 | 65              | 24         | 0.7 |
| 8033240 | 1.73/3 | 32 | 85              | 28         | 2.4 |



**1.74 Universal ball joint puller**

For removing the ball joint journals on track rods, stabilizers, etc. Simple operation due to slender lower part and two-stage lever position.

| Code    | No.    | mm | Clamping height | Fork depth |     |
|---------|--------|----|-----------------|------------|-----|
| 8085200 | 1.74/1 | 20 | 12-50           | 35         | 1.0 |
| 8085390 | 1.74/2 | 20 | 50-80           | 35         | 1.4 |



**1.75 Oil filter hook**  
**3-arm pattern**

For removing firmly seated oil filters.

| Code    | No.    | mm     | Drive   |     |
|---------|--------|--------|---|-----|
| 8117420 | 1.75/1 | 60-120 | without adaptor G 3/8,<br>with adaptor 17 mm external, G 1/2 internal | 0.6 |



**1.76 Cartridge spanner**  
**3-arm pattern**

For removing firmly seated granulate cartridges.

| Code    | No.    | mm     | Drive |     |
|---------|--------|--------|-------|-----|
| 1523651 | 1.76/1 | 80-150 | 1/2"  | 0.6 |

### 1.78 S Safety coil spring compressor

Safety coil spring compressor for the safe installation and removal of coil springs with a diameter of 110–180 mm. The spindles (M18) have 13 mm hexagon drive nut, so that when compressing the springs, they turn downwards, thus preventing damage to bodywork above the springs.

**Safety note:**

When the spindles are tightened evenly, the clamping heads grip the coils tightly, rendering sideways slip impossible. VPA-GS-tested safety.

| Code    | No.     | Clamping reach mm |  |
|---------|---------|-------------------|---|
| 8031110 | 1.78/S1 | 180               | 2.2   |
| 8031380 | 1.78/S2 | 280               | 2.5   |
| 8031460 | 1.78/S3 | 380               | 2.8   |



### 1.78 P Universal coil spring compressor

A coil spring compressor for MacPherson suspension strut and transverse link axles with spring diameters of 110–180 mm. Shock absorbers may be replaced without removing the suspension struts.

The safety holder renders slipping impossible.

VPA-GS-tested safety.

The hooks are drop forged.

The wide support rests are matched to the coil spring pitch.

| Code    | No.      | Clamping reach mm | max. t |  |
|---------|----------|-------------------|--------|---|
| 8111300 | 1.78/P1  | 240               | 3,5    | 3,5   |
| 8031030 | 1.78/PK1 | 240               | 3,5    | 3,5   |

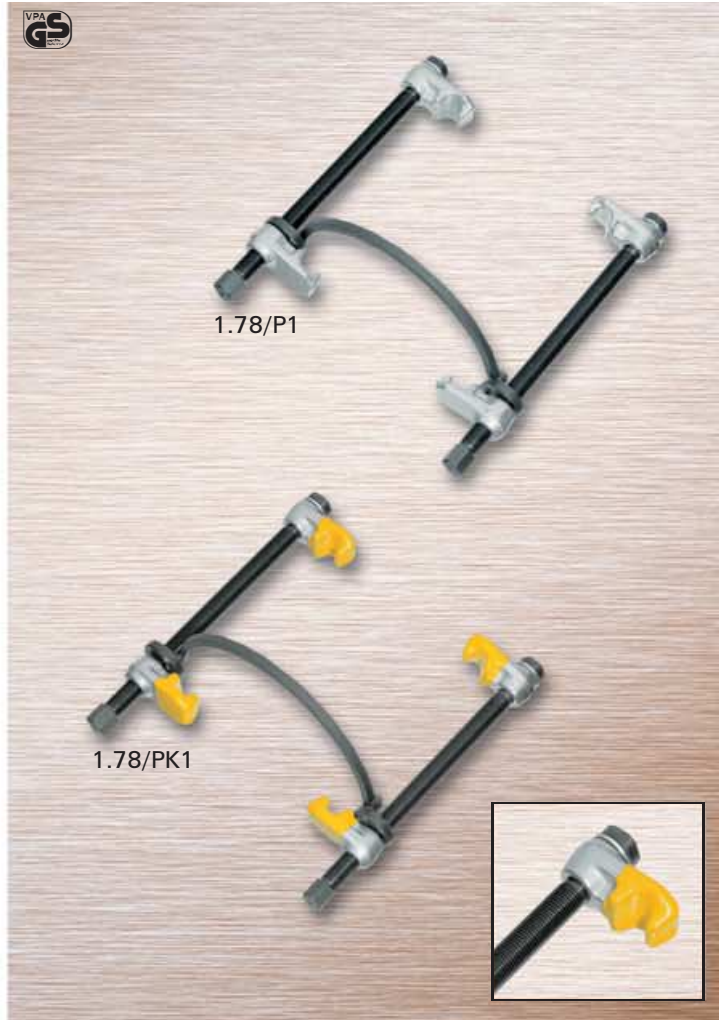

### 1.79 Spring spreader

This has been especially designed for VAG exhaust installations, where the pipe is not held by bolts to the exhaust manifold, but clamped on using springs.

| Code    | No.    |  |
|---------|--------|---|
| 8112540 | 1.79/1 | 0.4   |





### 1.80/1 Spindle pressure pads

for axle bores (hollow shafts)

The BALDUR pressure pads are used for the removal of such parts as bearings and gear wheels that are mounted on hollow shafts or in housings. Here, the spindle pressure pad serves as a counter-axis to the BALDUR puller, where the spindle now transfers the force to the pressure pad.

| Code    | No.    | Plate Ø mm | Holder Ø mm |     |
|---------|--------|------------|-------------|-----|
| 1120697 | 1.80/1 | 25         | 19          | 2.2 |
|         |        | 28         | 22          |     |
|         |        | 32         | 25          |     |
|         |        | 35         | 28          |     |
|         |        | 41         | 32          |     |
|         |        | 44         | 35          |     |
|         |        | 48         | 38          |     |
|         |        | 50         | 41          |     |
|         |        | 54         | 44          |     |
|         |        | 60         | 48          |     |
| 64      | 50     |            |             |     |

### 1.80/2 Spindle pressure pads

for axle bores (hollow shafts)

See No. 1.80/1 for description.

| Code    | No.    | Plate Ø mm | Holder Ø mm |     |
|---------|--------|------------|-------------|-----|
| 1120700 | 1.80/2 | 67         | 54          | 2.3 |
|         |        | 70         | 57          |     |
|         |        | 73         | 60          |     |
|         |        | 78         | 64          |     |
|         |        | 83         | 70          |     |
|         |        | 88         | 76          |     |
|         |        | 90         | 76          |     |

### 1.80/3 Spindle pressure pads

for axle bores (hollow shafts)

See No. 1.80/1 for description.

| Code    | No.    | Plate Ø mm | Holder Ø mm |     |
|---------|--------|------------|-------------|-----|
| 1120719 | 1.80/3 | 41         | 32          | 4.2 |
|         |        | 44         | 35          |     |
|         |        | 48         | 38          |     |
|         |        | 50         | 41          |     |
|         |        | 54         | 44          |     |
|         |        | 60         | 48          |     |
|         |        | 64         | 50          |     |
|         |        | 67         | 54          |     |
|         |        | 70         | 57          |     |
|         |        | 73         | 60          |     |
|         |        | 78         | 64          |     |
|         |        | 83         | 70          |     |
|         |        | 88         | 76          |     |
|         |        | 90         | 76          |     |

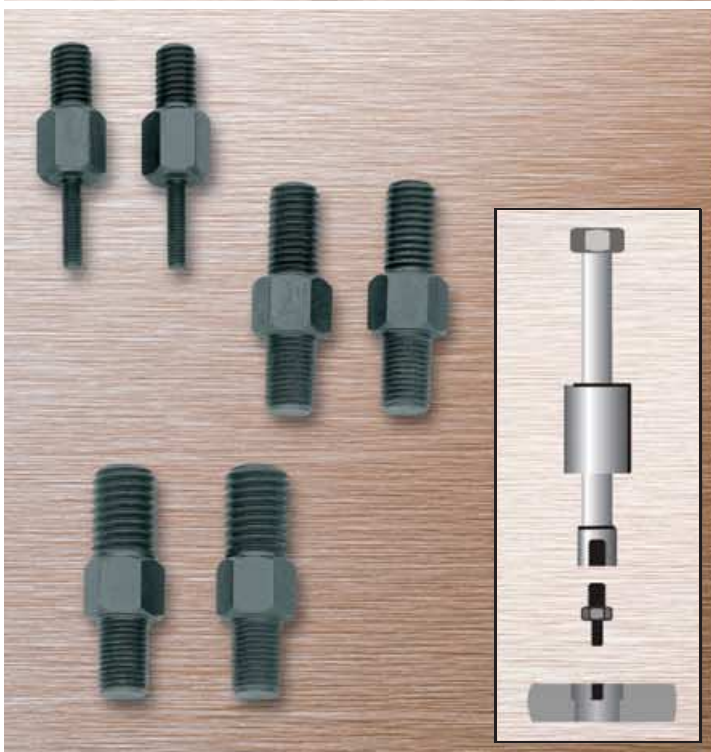

### 1.81/1 Threaded inserts

The BALDUR threaded inserts make the removal of threaded caps, for example, possible, when these possess one threaded hole.

For slide hammers 1.35/1, 1.35/2, threaded support 1.36/1.

| Code    | No.    | Connecting / Insert thread |     |
|---------|--------|----------------------------|-----|
| 1120727 | 1.81/1 | M 10 - M 4                 | 200 |
|         |        | M 10 - M 5                 |     |
|         |        | M 10 - M 6                 |     |
|         |        | M 10 - M 8                 |     |
|         |        | M 10 - M 10                |     |
|         |        | M 10 - M 12                |     |

### 1.81/2 Threaded inserts

See No. 1.81/1 for description.

For slide hammers 1.35/2, 1.36/2, threaded support 1.36/3.

| Code    | No.    | Connecting / Insert thread |     |
|---------|--------|----------------------------|-----|
| 1120743 | 1.81/2 | M 14x1,5 - M 8             | 470 |
|         |        | M 14x1,5 - M 10            |     |
|         |        | M 14x1,5 - M 12            |     |
|         |        | M 14x1,5 - M 14            |     |
|         |        | M 14x1,5 - M 16            |     |
|         |        | M 14x1,5 - M 18            |     |



**1.81/10 Threaded inserts**  
for 1-hole and 2-hole uses, 2 each

The BALDUR threaded inserts make the removal of threaded caps, for example, possible, when these possess one or two threaded holes. For separator puller 1.38/0, 1.38/1.

| Code    | No.     | Connecting / Insert thread |     |
|---------|---------|----------------------------|-----|
| 1120735 | 1.81/10 | M 10 - M 4                 | 460 |
|         |         | M 10 - M 5                 |     |
|         |         | M 10 - M 6                 |     |
|         |         | M 10 - M 8                 |     |
|         |         | M 10 - M 10                |     |
|         |         | M 10 - M 12                |     |
|         |         | Adaptor                    |     |

**1.81/20 Threaded inserts**  
for 1-hole and 2-hole uses, 2 each

See No. 1.81/10 for description.  
For separator puller 1.38/2.

| Code    | No.     | Connecting / Insert thread |      |
|---------|---------|----------------------------|------|
| 1120751 | 1.81/20 | M 14x1,5 - M 8             | 1010 |
|         |         | M 14x1,5 - M 10            |      |
|         |         | M 14x1,5 - M 12            |      |
|         |         | M 14x1,5 - M 14            |      |
|         |         | M 14x1,5 - M 16            |      |
|         |         | M 14x1,5 - M 18            |      |
|         |         | Adaptor                    |      |

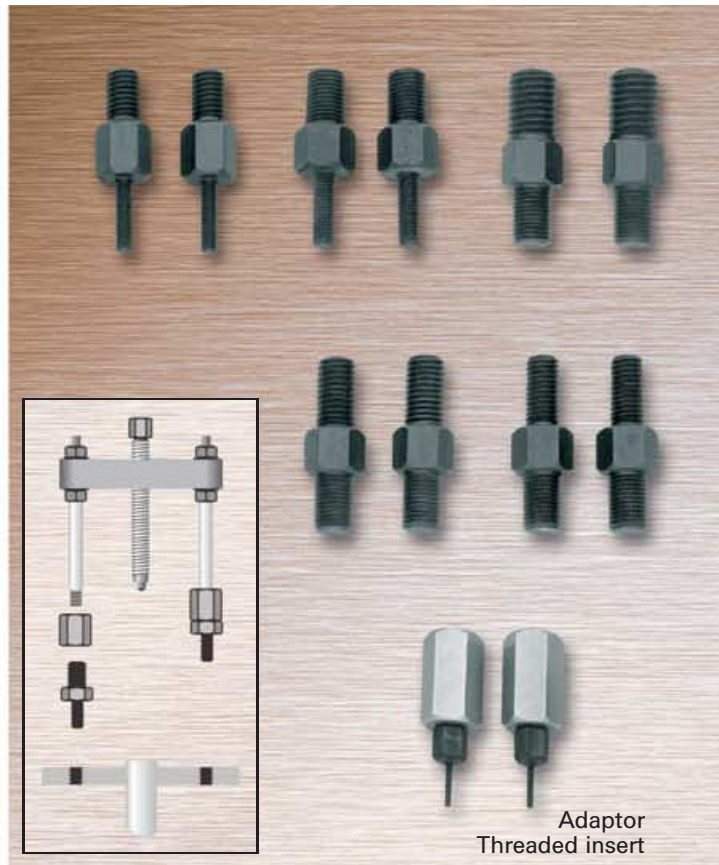

Adaptor  
Threaded insert



**1.85/1 Professional plastic bearing installation set**

This sturdy plastic bearing installation set combines the advantages of the usual models in metal with the advantages of plastic. The impact-resistant plastic is handily light, but just as robust as the metal variants. Using this bearing installation set, which consists of 33 impact rings, more than 200 types of bearings may be re-installed effortlessly and without damage. The set is completed with three aluminium impact sleeves and a recoil-free bodywork hammer with nylon heads, all in a strong plastic case. This set guarantees that the installed bearings will suffer no damage that might have happened when working "metal to metal". No deformations of the bearing housings, sealing rings, or shafts.

| Code    | No.    | Contents   |     |
|---------|--------|--|-----|
| 1120778 | 1.85/1 | Impact rings 10-50 mm, for external Ø 26-110 mm, hammer 1,2 kg, case dimensions 450 x 360 x 140 mm | 4.6 |



9

**1.91 Tyre removing tool**

For breaking the adhesion between truck tyres and wheel rims.

| Code    | No.  | (mm) |     |
|---------|------|------|-----|
| 8032270 | 1.91 | 300  | 1.8 |



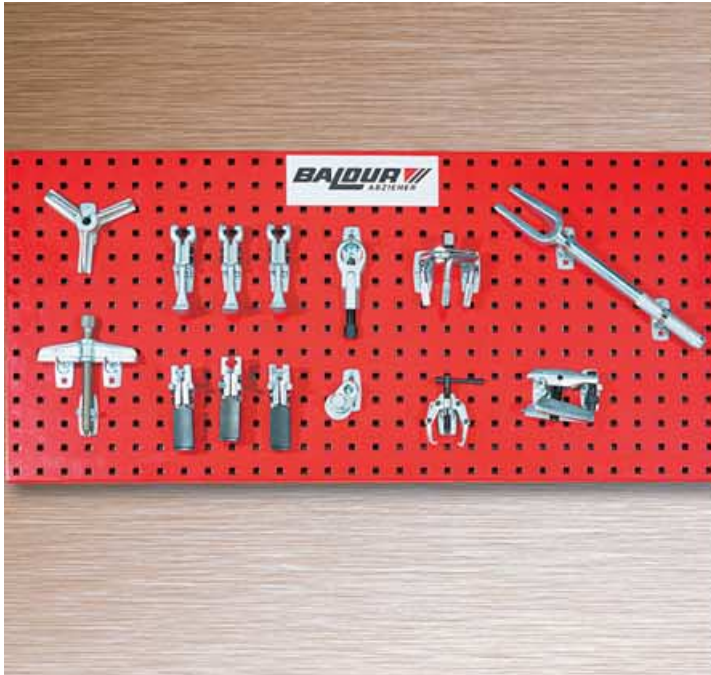

## 2.10 Automobile workshop set

### Add-on system

Clearly arranged module system, everything at hand on perforated wall-board.

| Code    | No.      | Contents                               |      |
|---------|----------|--|------|
| 1088696 | 2.10     | as below stated                        | 11.5 |
| Code    | No.      | Description                            | Qty. |
| 1076469 | 106/103  | Cross piece, 2-arm pattern, 140 mm     | 1    |
| 1076981 | 107/103  | Cross piece, 3-arm pattern, 140 mm     | 1    |
| 1120514 | 106/A    | Pulling hook, 100 mm                   | 3    |
| 1175343 | 106/S100 | Pulling hook, slim pattern, 100 mm     | 3    |
| 8003840 | 1.12/02  | Battery-terminal puller, 2-arm pattern | 1    |
| 8009610 | 1.26/2   | Nut splitter                           | 1    |
| 8010700 | 1.28/2   | Stud extractor                         | 1    |
| 8029480 | 1.70/2   | Dismantling and assembly fork          | 1    |
| 8030810 | 1.73/1   | Universal ball joint puller            | 1    |
| 8117420 | 1.75/1   | Oil filter hook                        | 1    |
| 1120638 | 71010    | Perforated board                       | 1    |
| 1081616 | 1500 H 1 | Hook                                   | 4    |
| 1081624 | 1500 H 2 | Spring clamp                           | 9    |
| 1081632 | 1500 H 3 | Spring clamp                           | 5    |



## 2.20 Truck workshop set

### Add-on system

Clearly arranged module system, everything at hand on perforated wall-board.

| Code    | No.       | Contents                           |      |
|---------|-----------|------------------------------------|------|
| 1088718 | 2.20      | as below stated                    | 14.0 |
| Code    | No.       | Description                        | Qty. |
| 1076612 | 106/2A03  | Cross piece, 2-arm pattern, 260 mm | 1    |
| 1077023 | 107/2A03  | Cross piece, 3-arm pattern, 260 mm | 1    |
| 1120530 | 106/B     | Pulling hook, 100 mm               | 3    |
| 1175475 | 106/S220  | Pulling hook, slim pattern, 220 mm | 3    |
| 1123947 | 106/BV    | Pulling hook, 300 mm               | 3    |
| 1084593 | 1.2106210 | Spindle                            | 1    |
| 8116100 | 1.06/HSP1 | Hydraulic pressure spindle         | 1    |
| 8019840 | 1.40/2    | Bearing separator                  | 1    |
| 1120638 | 71010     | Perforated board                   | 1    |
| 1081616 | 1500 H 1  | Hook                               | 10   |
| 1081632 | 1500 H 3  | Spring clamp                       | 5    |

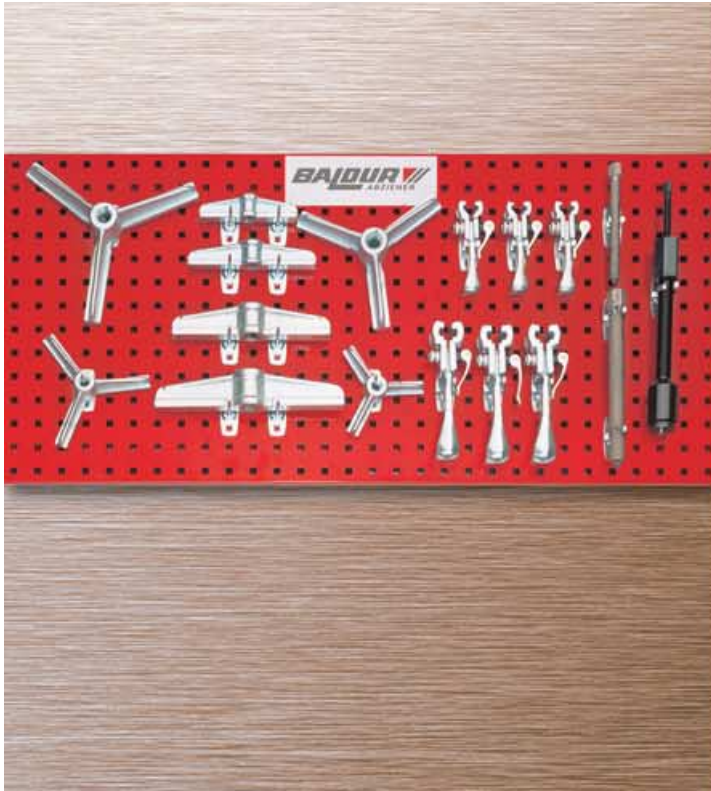

## 2.30 Industrial pulling set

### Add-on system

For the assembly of the tried and tested 1.06 and 1.07 versions. Using this set, you will be able to assemble more than 12 of the usual versions with high-speed clamping hooks, including hydraulic spindle, in seconds.

| Code    | No.       | Contents                           |      |
|---------|-----------|------------------------------------|------|
| 1393014 | 2.30      | as below stated                    | 17.5 |
| Code    | No.       | Description                        | Qty. |
| 1076469 | 106/103   | Cross piece, 2-arm pattern, 140 mm | 1    |
| 1076485 | 106/1A03  | Cross piece, 2-arm pattern, 180 mm | 1    |
| 1076590 | 106/203   | Cross piece, 2-arm pattern, 220 mm | 1    |
| 1076612 | 106/2A03  | Cross piece, 2-arm pattern, 260 mm | 1    |
| 1076981 | 107/103   | Cross piece, 3-arm pattern, 140 mm | 1    |
| 1077007 | 107/1A03  | Cross piece, 3-arm pattern, 180 mm | 1    |
| 1077015 | 107/203   | Cross piece, 3-arm pattern, 220 mm | 1    |
| 1077023 | 107/2A03  | Cross piece, 3-arm pattern, 260 mm | 1    |
| 1084488 | 1.1406140 | Spindle                            | 1    |
| 1084593 | 1.2106210 | Spindle                            | 1    |
| 8116100 | 1.06/HSP1 | Hydraulic pressure spindle         | 1    |
| 1178199 | 106/A-E   | Pulling hook                       | 3    |
| 1178253 | 106/B-E   | Pulling hook                       | 3    |
| 1120638 | 71010     | Perforated board                   | 1    |
| 1081616 | 1500 H 1  | Hook                               | 12   |
| 1081624 | 1500 H 2  | Spring clamp                       | 4    |
| 1081632 | 1500 H 3  | Spring clamp                       | 6    |

## 2.40 Pulling set for construction machines

### Add-on system

For the assembly of the robust and handy strap-pattern pulling tools 1.14 and 1.15.

With this set, you will be able to assemble 10 of the usual flexible strap-pattern pulling tools from the range 1.14/1.15, including the new hydraulic spindle.

| Code    | No.               | Contents                   |      |
|---------|-------------------|----------------------------|------|
| 1393030 | 2.40              | as below stated            | 24.5 |
| Code    | No.               | Description                | Qty. |
| 1077856 | 114/204           | Head                       | 1    |
| 1077910 | 114/304           | Head                       | 1    |
| 1078054 | 115/204           | Head                       | 1    |
| 1078070 | 115/304           | Head                       | 1    |
| 1084569 | 1.1806200         | Spindle                    | 1    |
| 1084631 | 1.2106250         | Spindle                    | 1    |
| 8116100 | 1.06/HSP1         | Hydraulic pressure spindle | 1    |
| 1077821 | 114/201           | Pulling hook, 210 mm       | 3    |
| 1077899 | 114/301           | Pulling hook, 260 mm       | 3    |
| 1077953 | 114/401           | Pulling hook, 390 mm       | 3    |
| 1077872 | 114/208           | Strap                      | 6    |
| 1077937 | 114/308           | Strap                      | 6    |
| 1120638 | 71010             | Perforated board           | 1    |
| 1081616 | 1500 H 1          | Hook                       | 6    |
| 1081624 | 1500 H 2          | Spring clamp               | 2    |
| 1081632 | 1500 H 3          | Spring clamp               | 20   |
| Code    | Accessories No.   |                            | Qty. |
| 1075225 | Hexagon bolt M10  |                            | 6    |
| 1075144 | Hexagon bolt M12  |                            | 12   |
| 1074946 | Hexagon nut M10   |                            | 6    |
| 1074954 | Hexagon nut M12   |                            | 12   |
| 1074431 | Spring washer M10 |                            | 6    |
| 1074458 | Spring washer M12 |                            | 12   |



Dump truck at work.

## 3.01 Track alignment gauge

For inside measurement.

Suitable for all vehicle types.

With simple, telescopic length adjustment.

Immediate track-difference readings may be taken from the millimetre scale. Extensive measurement range from 835 to 1500 mm, and with extensions up to 2100 mm.

Track difference measurable from 0–35 mm.

### Notes on Use:

The vehicle to be tested must be standing on level ground.

The front wheels must be set for running straight ahead and have the same tyre pressure.

The play in the steering linkage must be removed by pressing the front wheels apart.

The track alignment gauge must be set roughly at the axle centre-line between the front tyres in such a manner that the two chain ends contact the ground.

The scale is set a "0".

The car is allowed to roll forward approx. one half turn of the wheel, until the chain ends again contact the ground.

The track difference may then be read off on the scale.

| Code    | No.    | Description                         | Measurement range |     |
|---------|--------|-------------------------------------|-------------------|-----|
| 8033080 | 3.01   | Track alignment gauge               | 835-1500          | 2.0 |
| 8033160 | 3.01/V | Extension for track alignment gauge | 1500-2100         | 0.4 |



## **X-ON Electronics**

Largest Supplier of Electrical and Electronic Components

*Click to view similar products for [gedore](#) manufacturer:*

Other Similar products are found below :

[6 10X11](#) [4549-02](#) [IN 20 3](#) [33 T 7](#) [6 13X17](#) [7 R 8](#) [6 6X7](#) [IN 19 8](#) [6 13X14](#) [1.13/01](#) [6 8X10](#) [017500](#) [016500](#) [IN 20 6](#)