

LDO



Low Iq LDO Regulator - EVK BD7xxL2EFJ/FP/FP3-CE2

ROHM LDO IC Evaluation Kit

● Abstract

This evaluation board manual describes the usage of ROHM's LDO IC evaluation kit (EVK) called BD7xxL2EFJ/FP/FP3-CE2 EVK. This document provides guidelines to quickly setup the hardware for IC performance evaluation.

● Description of Supported ICs

This EVK is an LDO IC evaluation board. The application of the board is to let a user evaluate the performance of the BD7xxL2xxx-CE2 LDO. The function of the board is to linearly regulate a wide input DC voltage range to a fixed output DC voltage level. There are two voltage levels (3.3V and 5V) and 3 types of packages HTSOP-J8, TO252-3 and SOT223-4F. The LDO IC features low consumption current of 6uA, integrated overcurrent and thermal shutdown protection, low saturation voltage by using PMOS output transistor and high output voltage accuracy of ±2%.

● EVK Applications

This EVK is

- only to be used as device under test for research and development and the purpose of IC evaluation.
- only to be operated by trained professionals.
- not intended to be assembled into other products.

● EVK Key Specifications (Across Model Versions)

- Absolute maximum input voltage45V
- Output current capability.....200mA
- Output voltage.....3.3V or 5V



SOT223-4F



TO252-3



HTSOP-J8



Table of Contents

Cover Page.....	1
● Abstract	1
● Description of Supported ICs.....	1
● EVK Applications	1
● EVK Key Specifications (Across Model Versions)	1
1. Introduction.....	3
1.1 Operating instructions	3
1.2 Electrical Parameters / EVK Model Overview	3
2. Hardware Description	4
2.1 Schematic	4
2.1 Bill of Materials.....	4
3. Safety Instructions	5
3.1 Warnings.....	5
3.2 Instructions for Safe Use.....	5

1. Introduction

This EVK is an LDO IC evaluation board. The application of the board is to let a user evaluate the performance of the BD7xxL2EFJ/FP/FP3-CE2 LDO. The purpose of the EVK is to allow the test and evaluation of the LDO IC in professional research and development environments. This document provides guidelines to quickly setup the hardware for fast and easy LDO IC performance evaluation. For further details about the LDO ICs and other ROHM products, please also consult the relevant product datasheets and general information at <http://www.rohm.com>.

1.1 Operating instructions

A block diagram of the EVK application is depicted in Figure 1. In order to evaluate the board apply input voltage, connect the DC load and measure the output voltage of the LDO. Note: when connecting laboratory equipment and other peripherals do not use cables with length more than 3 meters due to EMC compliance.

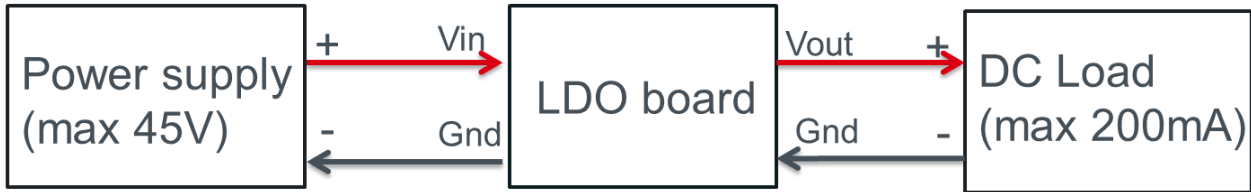

Figure 1: EVK operating block diagram

1.2 Electrical Parameters / EVK Model Overview

This LDO EVK has 6 different model variants. The main difference between the variants is the package of the LDO and output voltage level. Table 1 gives an overview of the different IC features and the according naming of the EVK.

Parameter	Symbol	Value			Unit	EVK Model	
		Min	Typ	Max			
Input	Current	lin		6		uA	BD7xxL2xxx
	Voltage	Vin	4.3		45	V	BD733L2xxx
5.8				45	V	BD750L2xxx	
Output	Current	lout	0		200	mA	BD7xxL2xxx
	Voltage	Vout	3.2	3.3	3.37	V	BD733L2xxx
			4.9	5.0	5.1	V	BD750L2xxx
LDO IC Package			HTSOP-J8				BD7xxL2EFJ
			TO252-3				BD7xxL2FP
			SOT223-4F				BD7xxL2FP3

Table 1: EVK Model Variants

2. Hardware Description

The schematic of the EVK is shown in Figure 2 and the Bill-of-Materials (BOM) is summarized Table 2. Besides the LDO IC the main part of the EVK is the input supply decoupling capacitor and output filtering capacitor.

2.1 Schematic

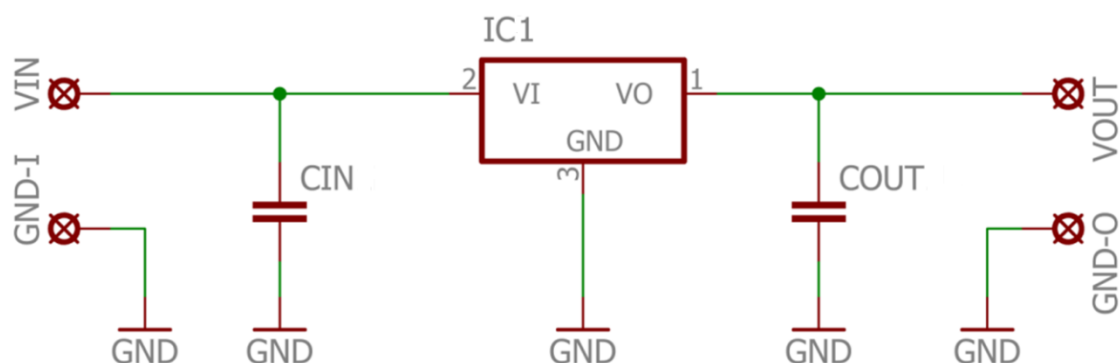

Figure 2: EVK Schematic

2.1 Bill of Materials

No.	Value	Description	Size	Part number	Manufacturer	EVK Model
IC1		Low Iq LDO		BD733L2EFJ-CE2	ROHM	BD733L2EFJ
				BD750L2EFJ-CE2		BD750L2EFJ
				BD733L2FP-CE2		BD733L2FP
				BD750L2FP-CE2		BD750L2FP
				BD733L2FP3-CE2		BD733L2FP3
				BD750L2FP3-CE2		BD750L2FP3
CIN	1uF	Capacitor, 50V, X5R	0603	C1608X5R1H105K080AB	TDK	all
COUT	4.7uF	Capacitor, 10V, X5R	0603	CGB3B1X5R1A475M055AC	TDK	all

Table 2: Bill of Materials

3. Safety Instructions

3.1 Warnings

- This product should be operated in a well ventilated environment and, if used inside a case, the case should not be covered.
- This product should be placed on a stable, flat, non-conductive surface in use and should not be contacted by conductive items.
- All peripherals used with the EVK should comply with relevant standards for the country of use and be marked accordingly to ensure that safety and performance requirements are met.
- Where peripherals are connected that do not include the cable or connector, the cable or connector used must offer adequate insulation and operation in order that the requirements of the relevant performance and safety are met.
- The connection of incompatible devices to the EVK may affect compliance or result in damage to the unit and invalidate the warranty.

3.2 Instructions for Safe Use

- Do not expose it to water, moisture or place on a conductive surface whilst in operation.
- Do not expose it to temperatures, which are out of the operational range specified for hardware and components populating the EVK.
- Take care whilst handling to avoid mechanical or electrical damage to the printed circuit board and components
- Avoid handling the printed circuit board while it is powered. Only handle by the edges to minimize the risk of electrostatic discharge damage.

Notes

1. The information contained herein is subject to change without notice.
2. Before you use our Products, please contact our sales representative and verify the latest specifications :
3. Although ROHM is continuously working to improve product reliability and quality, semiconductors can break down and malfunction due to various factors. Therefore, in order to prevent personal injury or fire arising from failure, please take safety measures such as complying with the derating characteristics, implementing redundant and fire prevention designs, and utilizing backups and fail-safe procedures. ROHM shall have no responsibility for any damages arising out of the use of our Products beyond the rating specified by ROHM.
4. Examples of application circuits, circuit constants and any other information contained herein are provided only to illustrate the standard usage and operations of the Products. The peripheral conditions must be taken into account when designing circuits for mass production.
5. The technical information specified herein is intended only to show the typical functions of and examples of application circuits for the Products. ROHM does not grant you, explicitly or implicitly, any license to use or exercise intellectual property or other rights held by ROHM or any other parties. ROHM shall have no responsibility whatsoever for any dispute arising out of the use of such technical information.
6. The Products are intended for use in general electronic equipment (i.e. AV/OA devices, communication, consumer systems, gaming/entertainment sets) as well as the applications indicated in this document.
7. The Products specified in this document are not designed to be radiation tolerant.
8. For use of our Products in applications requiring a high degree of reliability (as exemplified below), please contact and consult with a ROHM representative: transportation equipment (i.e. cars, ships, trains), primary communication equipment, traffic lights, fire/crime prevention, safety equipment, medical systems, servers, solar cells, and power transmission systems.
9. Do not use our Products in applications requiring extremely high reliability, such as aerospace equipment, nuclear power control systems, and submarine repeaters.
10. ROHM shall have no responsibility for any damages or injury arising from non-compliance with the recommended usage conditions and specifications contained herein.
11. ROHM has used reasonable care to ensure the accuracy of the information contained in this document. However, ROHM does not warrants that such information is error-free, and ROHM shall have no responsibility for any damages arising from any inaccuracy or misprint of such information.
12. Please use the Products in accordance with any applicable environmental laws and regulations, such as the RoHS Directive. For more details, including RoHS compatibility, please contact a ROHM sales office. ROHM shall have no responsibility for any damages or losses resulting non-compliance with any applicable laws or regulations.
13. When providing our Products and technologies contained in this document to other countries, you must abide by the procedures and provisions stipulated in all applicable export laws and regulations, including without limitation the US Export Administration Regulations and the Foreign Exchange and Foreign Trade Act.
14. This document, in part or in whole, may not be reprinted or reproduced without prior consent of ROHM.



Thank you for your accessing to ROHM product information.
More detailed product information and catalogs are available, please contact us.

ROHM Customer Support System

<http://www.rohm.com/contact/>

X-ON Electronics

Largest Supplier of Electrical and Electronic Components

Click to view similar products for [rohm](#) manufacturer:

Other Similar products are found below :

[R6015ENZC8](#) [BP5034D24](#) [BP5013](#) [BP5011](#) [BP5718A12](#) [R6035ENZC8](#) [RN142ZST2R](#) [RB520S-40TE61](#) [RB886YT2R](#) [RB851YT2R](#)
[MCR100JZHF30R1](#) [MCR100JZHJ150](#) [MCR50JZHFLR820](#) [MCR50JZHJ330](#) [ML610Q793-SDK](#) [MNR34J5ABJ223](#) [BD750L2FP-EVK-301](#)
[BD9009HFP-EVK-001](#) [BD9285F-GE2](#) [KTR10EZPF2203](#) [SML-810TBT86](#) [RB168L-60TE25](#) [MCR100JZHF1301](#) [MCR100JZHJ4R3](#)
[MCR100JZHJ513](#) [MCR100JZHJ683](#) [MCR10EZHF SR062](#) [BD9B300MUV-EVK-001](#) [MNR12ERAPJ100](#) [RF1501TF3S](#) [MNR34J5ABJ221](#)
[BD9060HFP-EVK-001](#) [BD9611MUV-EVK-001](#) [BD9778HFP-TR](#) [BD9C601EFJ-EVK-001](#) [BD9D321EFJ-EVK-101](#) [BA7603F-E2](#)
[BD95820N-LB](#) [BD9A100MUV-EVK-001](#) [BD9C401EFJ-EVK-001](#) [BD9C501EFJ-EVK-001](#) [BU90005GWZ-E2-EVK-101](#) [846-1001-KIT](#)
[LA-401XD](#) [SLA560WBD2PT2](#) [BH1790GLC-EVK-001](#) [BD9B301MUV-EVK-101](#) [BA7071F-E2](#) [SK-AD01-D62Q1367TB](#) [BM2P129TF-EVK-001](#)