

LTC4224

Compact Dual Low Voltage Hot Swap Controller

DESCRIPTION

Demonstration circuit DC1364 features the LTC4224 Compact Dual Low Voltage Hot Swap Controller.

DC1364 facilitates evaluation of the LTC4224 performance characteristics including supply ramp-up transients, steady state, and overcurrent fault conditions. Onboard LEDs indicate input supply presence, output supply, and fault conditions. Layout is optimized for narrow pitch

designs, with a dual SO-8 FET on the back side of the board.

Design files for this circuit board are available. Call the LTC factory.

LT, LTC, LTM, LT, Burst Mode, OPTI-LOOP, Over-The-Top and PolyPhase are registered trademarks of Linear Technology Corporation. Adaptive Power, C-Load, DirectSense, Easy Drive, FilterCAD, Hot Swap, LinearView, μ Module, Micropower SwitcherCAD, Multimode Dimming, No Latency $\Delta\Sigma$, No Latency Delta-Sigma, No RSENSE, Operational Filter, PanelProtect, PowerPath, PowerSOT, SmartStart, SoftSpan, Stage Shedding, SwitcherCAD, ThinSOT, UltraFast and VLDO are trademarks of Linear Technology Corporation. Other product names may be trademarks of the companies that manufacture the products.

PERFORMANCE SUMMARY Specifications are at TA = 25°C

SYMBOL	PARAMETER	CONDITIONS	MIN	TYP	MAX	UNITS
V_{CC}	V_{CC} Supply Voltage Range	$V_{CC} = \text{Max}(V_{CC1}, V_{CC2})$	2.7		6.0	V
$V_{CC(UVL)}$	V_{CC} Undervoltage Lockout	V_{ICC} Rising	2.2	2.37	2.65	V
V_{CCLO}	V_{CCLO} Supply Range	$V_{CCLO} = \text{Min}(V_{CC1}, V_{CC2}), V_{CC} \geq 2.7V$	1.0		6.0	V
$V_{CCLO(UVL)}$	Undervoltage Lockout	V_{CCLO} Falling	0.76	0.8	0.84	V
ΔV_{GATE}	Gate Drive ($V_{GATEn} - V_{CC}$)	$I_{GATEn} = 0\mu A, -1\mu A$	4.5	5.5	7	V
$\Delta V_{SENSE(CB)}$	Circuit Breaker Trip Sense Voltage ($V_{CCn} - SENSEn$)	$(V_{IN} - V_{OUT}) V_{IN} = 3.6V$	22.5	25	27.5	mV
$V_{ON(TH)}$	\overline{ONn} Threshold Voltage	V_{ONn} Rising	0.76	0.8	0.84	V
$\Delta V_{ON(HYST)}$			15	30	50	mV
$I_{ON(IN)}$	\overline{ONn} Pull-Up Current	$V_{ON} = 0.6V$	5	10	15	μA

OPERATING PRINCIPLES

The LTC4224 controls two rails with external N-channel MOSFETs. Either supply rail operates as low as 1V, provided the other supply is 2.7V or greater. The maximum operating voltage is 6.0V for both channels. The LTC4224 can ramp up supplies in any order, and the output voltage slew rate is adjustable with external gate capacitors. All timing delays are generated internally, with

no need for additional timing components. A fast-acting current limiting amplifier and timed circuit breaker protect the load and power MOSFETs from excessive power dissipation in overcurrent conditions.

The supply rails turn on and off independently under control of the $\overline{ON1}$ and $\overline{ON2}$ inputs. Each \overline{ON} input is pulled high by internal 10 μA current source.

The gate voltage comes up when one of the two rail voltages exceeds the 2.4V undervoltage lock out level for 160ms and the associated \overline{ON} control signal drop to less than 0.8V. The gate driver is a 10uA current source that ramps the gate voltage to 5.5V above the rail voltage.

The Active Current Limiting (ACL) amplifier controls gate voltage to regulate 25mV across the sense resistor

The LTC4224-1 latches off after a current fault, while the LTC4224-2 automatically restarts following a cool down delay.

DC1634 is designed for operation with +5V, 1A rail (channel 1) and +3.3V, 2A rail (channel 2).

QUICK START PROCEDURE

Demonstration circuit DC1364 is easy to set up to evaluate the performance of the LTC4224. Refer to Figure 1 for proper measurement equipment setup and follow the procedure below:

1. Place jumpers in the following positions:

JP1 VIN1

JP2 OFF

JP3 OFF

2. With the power off, connect the +5.0V and +3.3V power supplies to the VIN1, VIN2 and GND turrets.

3. Connect VOUT1, VOUT2 and GND turrets to appropriate (+5.0V, 3A and +3.3V, 5.0A) disabled electronic loads or passive resistive loads (2.7 Ohms and 1.0 Ohms.)

4. Connect voltmeters to the \overline{FAULT} , VOUT1, and VOUT2 turrets. Turn on the +5.0V and +3.3V supplies. Two green LEDs VIN1 and VIN2 should light.

5. Turn on the +5.0V rail by placing JP2 (ON1) to the ON position. Green LED D3 (VOUT1) should light

6. Turn on the +3.3V rail by placing JP3 (ON2) to the ON position. Green LED D4 (VOUT2) should light.

7. Turn on electronic loads and verify circuit breaker thresholds: (1.46-1.85) A for the +5.0V rail and (2.23-2.80) A for the +3.3V rail.

8. The red FAULT led (D5) indicates an overcurrent fault on either rail. Toggling the ON signal to the faulted rail clears the fault.

9. Verify supply ramp up using a capacitive load on the +5.0V rail. A 1200uF load should power up properly, while a 2200uF load should cause a fault.

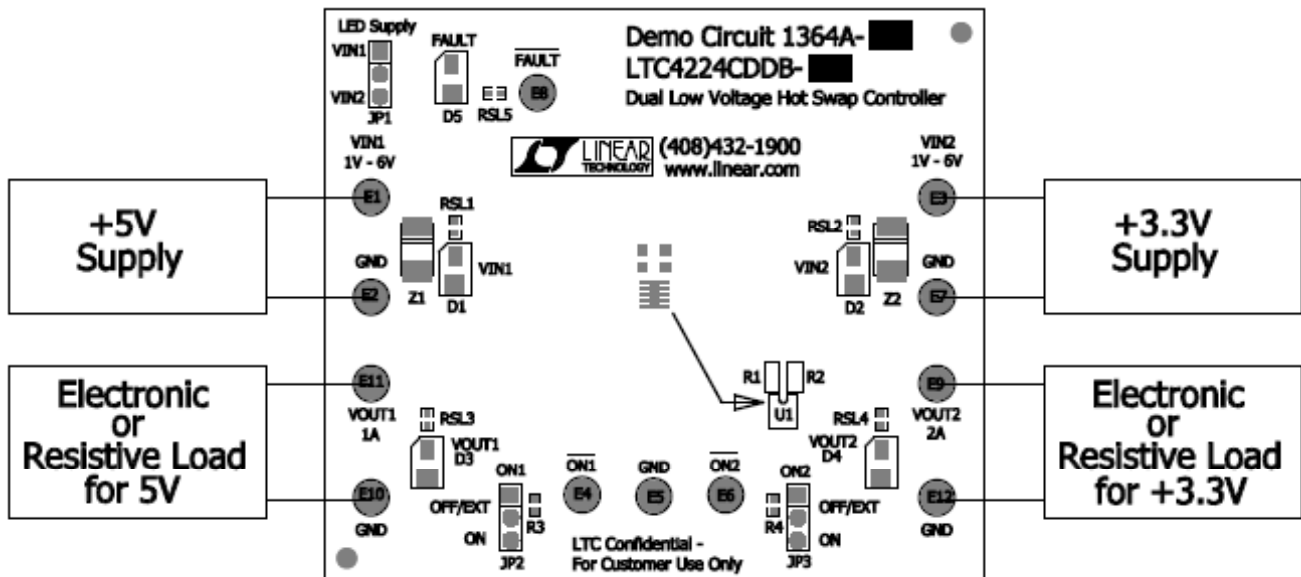
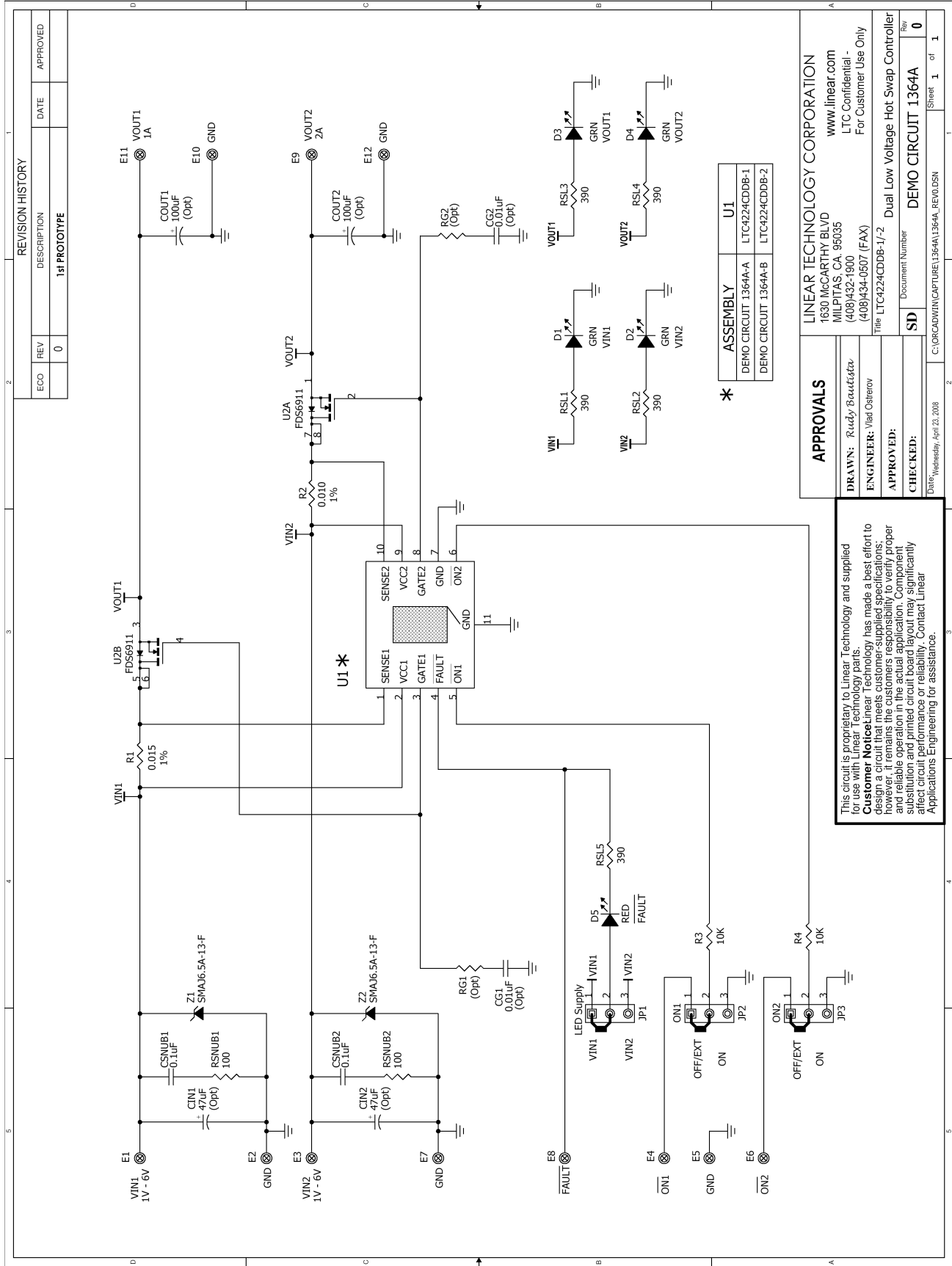

Figure 1. Proper Measurement Equipment Setup



X-ON Electronics

Largest Supplier of Electrical and Electronic Components

Click to view similar products for [Power Management IC Development Tools](#) category:

Click to view products by [Linear Technology](#) manufacturer:

Other Similar products are found below :

[EVAL6482H-DISC](#) [EVAL-AD5522EBUZ](#) [EVAL-ADM1060EBZ](#) [EVAL-ADM1073MEBZ](#) [EVAL-ADM1166TQEBZ](#) [EVAL-ADM1168LQEBZ](#) [EVAL-ADM1171EBZ](#) [EVAL-ADM1276EBZ](#) [EVB-EN5319QI](#) [EVB-EN5365QI](#) [EVB-EN6347QI](#) [EVB-EP5348UI](#) [MIC23158YML EV](#) [MIC23451-AAAYFL EV](#) [MIC5281YMME EV](#) [124352-HMC860LP3E](#) [ADM00513](#) [ADM8611-EVALZ](#) [ADM8612-EVALZ](#) [ADM8613-EVALZ](#) [ADP1046ADC1-EVALZ](#) [ADP1055-EVALZ](#) [ADP122-3.3-EVALZ](#) [ADP130-0.8-EVALZ](#) [ADP130-1.2-EVALZ](#) [ADP130-1.5-EVALZ](#) [ADP130-1.8-EVALZ](#) [ADP160UJZ-REDYKIT](#) [ADP166UJ-EVALZ](#) [ADP1712-3.3-EVALZ](#) [ADP1714-3.3-EVALZ](#) [ADP1715-3.3-EVALZ](#) [ADP1716-2.5-EVALZ](#) [ADP1740-1.5-EVALZ](#) [ADP1752-1.5-EVALZ](#) [ADP1754-1.5-EVALZ](#) [ADP1828LC-EVALZ](#) [ADP1870-0.3-EVALZ](#) [ADP1871-0.6-EVALZ](#) [ADP1873-0.6-EVALZ](#) [ADP1874-0.3-EVALZ](#) [ADP1876-EVALZ](#) [ADP1879-1.0-EVALZ](#) [ADP1882-1.0-EVALZ](#) [ADP1883-0.6-EVALZ](#) [ADP197CB-EVALZ](#) [ADP199CB-EVALZ](#) [ADP2102-1.25-EVALZ](#) [ADP2102-1.2-EVALZ](#) [ADP2102-1.875EVALZ](#)