

SYMBOL DEFINITION		TOTAL NO OF INSPECTIONS REQUIRED	
A DIMENSION WITHOUT AN INSPECTION REPORT SYMBOL DOES NOT REQUIRE INSPECTION. IT MAY BE CONTROLLED ON THE INDIVIDUAL COMPONENT DRAWING.		10	
	LAST NO. USED	10	

DWG STATUS				REVISION HISTORY				AUTH		DR		APVD	
DATE	STG	REV	W/P	CHG	ZONE								
14JAO0	R	001	-	-		CLEARED REV COLUMN: ALL ACTIVE PARTS-UPDATED PDM ATTRIBUTES	196648	CRW	081	LLD			
17JL00	R	002	-	-		REINSTATE 12077412	000010	JIB	JIB	JA			
150C04	R	03	-	-		ALL ACTIVE PARTS - ADDED TERMINAL ID NOTE	260003	RTV	JVM	MKM			
24FE05	R	04	-	-		ALL ACTIVE PARTS - REVISED MAT'L SPEC & DRAWING NAME	265136	JS	JS	TM			
18MY05	R	05	-	-		12176389 - UPDATED PDM ATTRIBUTES	268280	JBD	FKV	WTM			
30SE05	R	06	-	-		12077411, 12077413, 12084201, 12129493 & 12176389 - UPDATED PDM ATTRIBUTES; 12077411 - ADDED 1.0 MM² CABLE; ALL ACTIVE PARTS - ADDED NOTE# 6	272905	JTV	AUG	WTM			
11JAO8	R	07	-	-		ALL PARTS - 2X 5 +/-0.15 TYP WAS 2X 5 +/-0.01 TYP	403419	WHC	WHC	WTM			
18FE15	R	08	-	-		33231919 - RELEASED AND 12176387-90 - ADDED TARNISH NOTE	428904	NRM	JVM	DS			

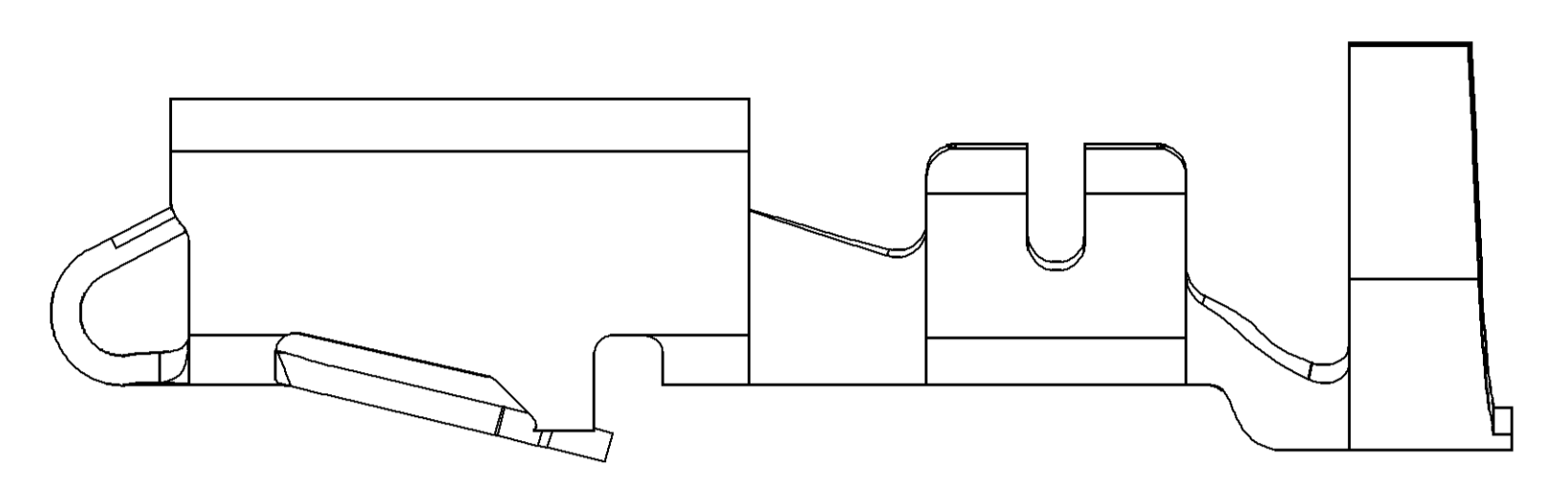

TYPE 102
SAME AS TYPE 101
EXCEPT AS SHOWN

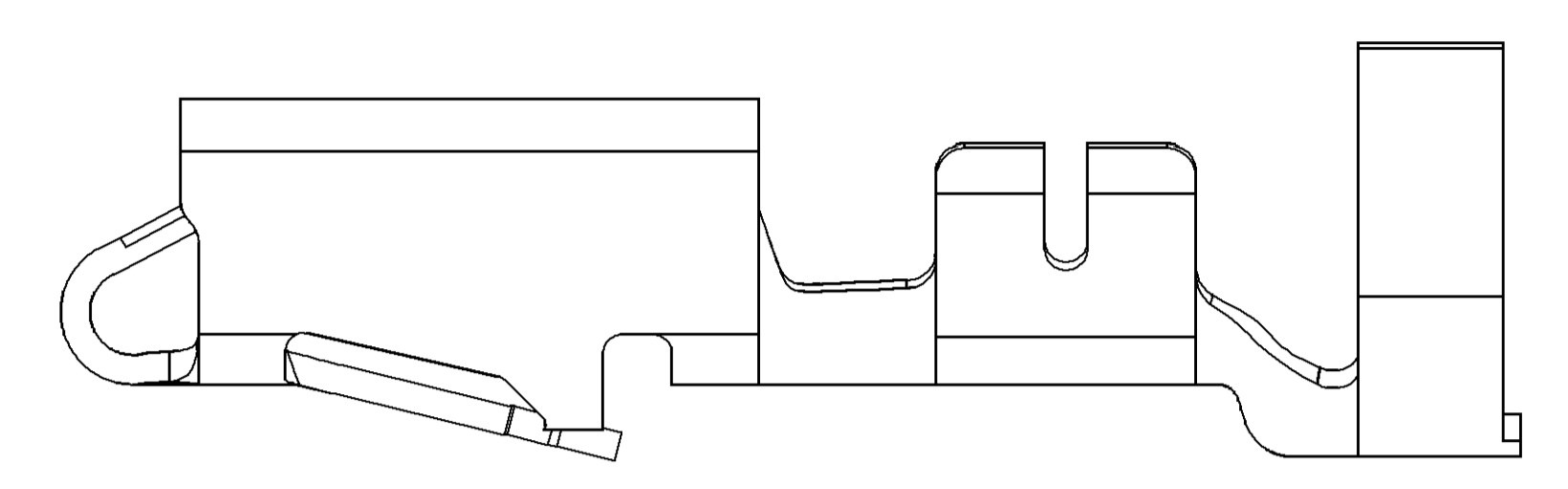

TYPE 103
SAME AS TYPE 101
EXCEPT AS SHOWN

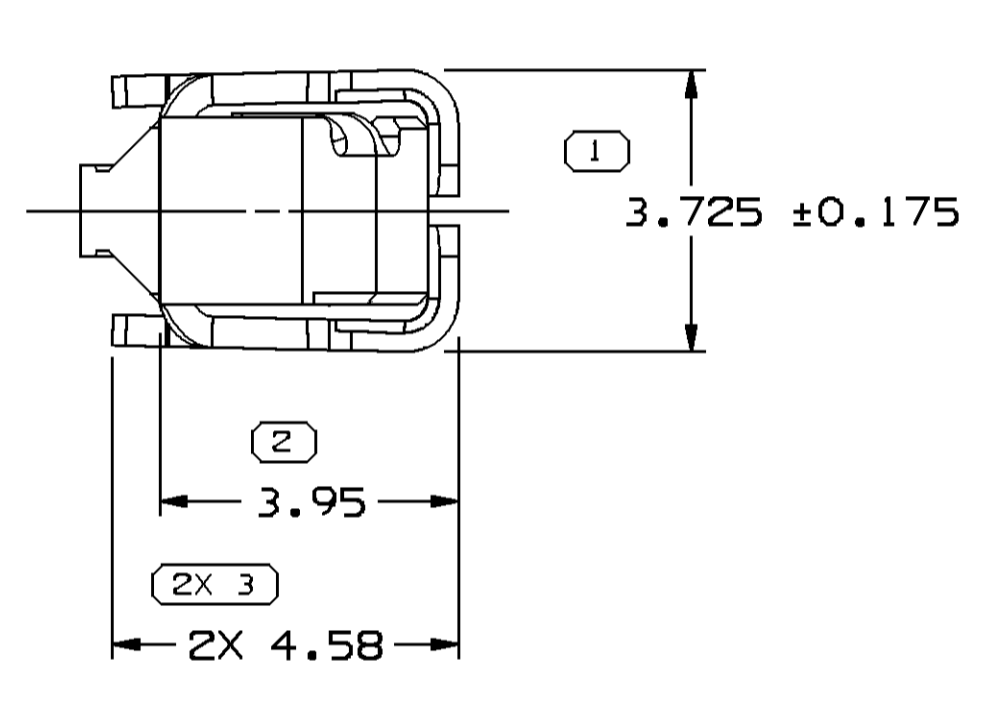
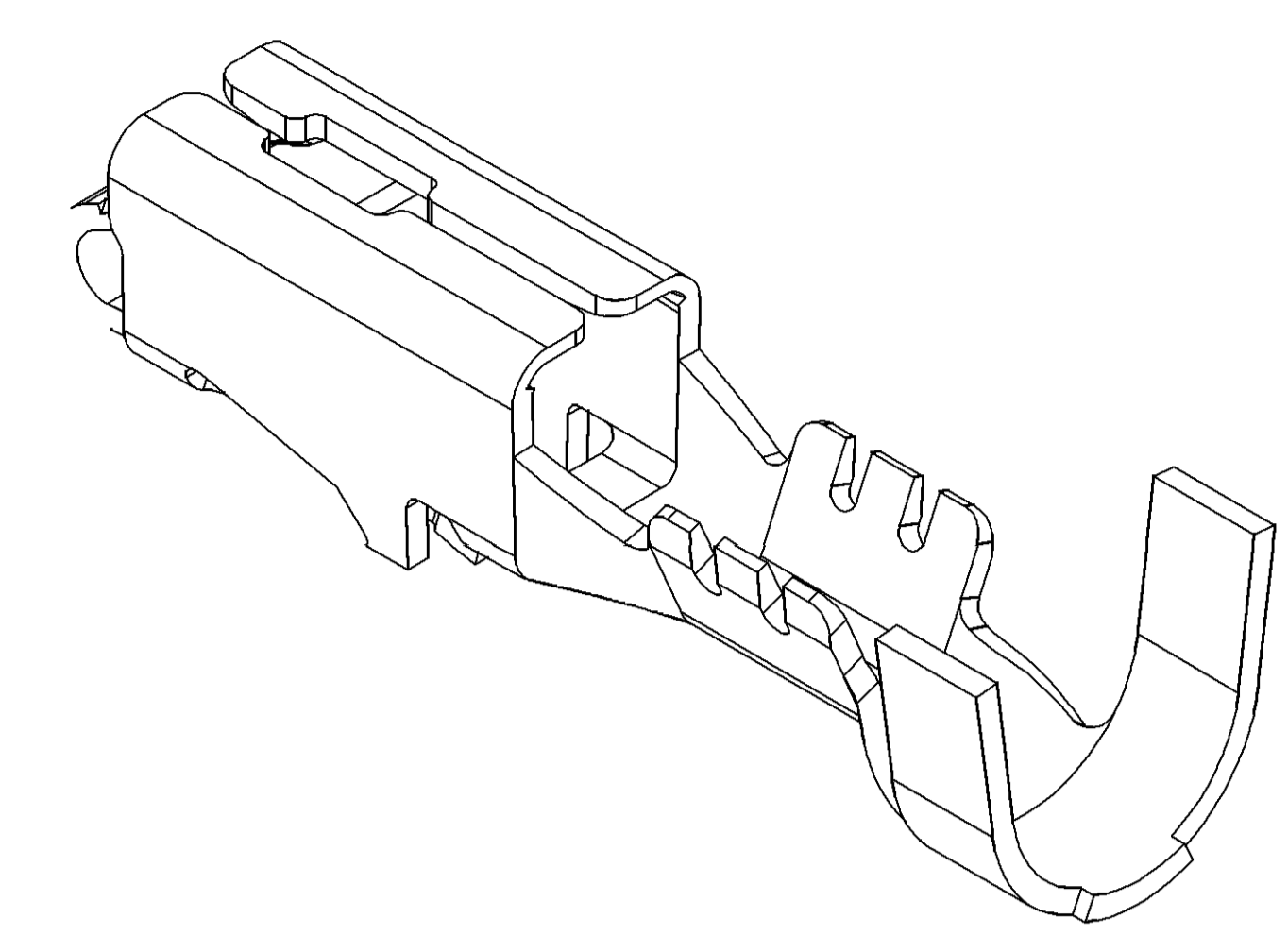

VIEW TO X-X

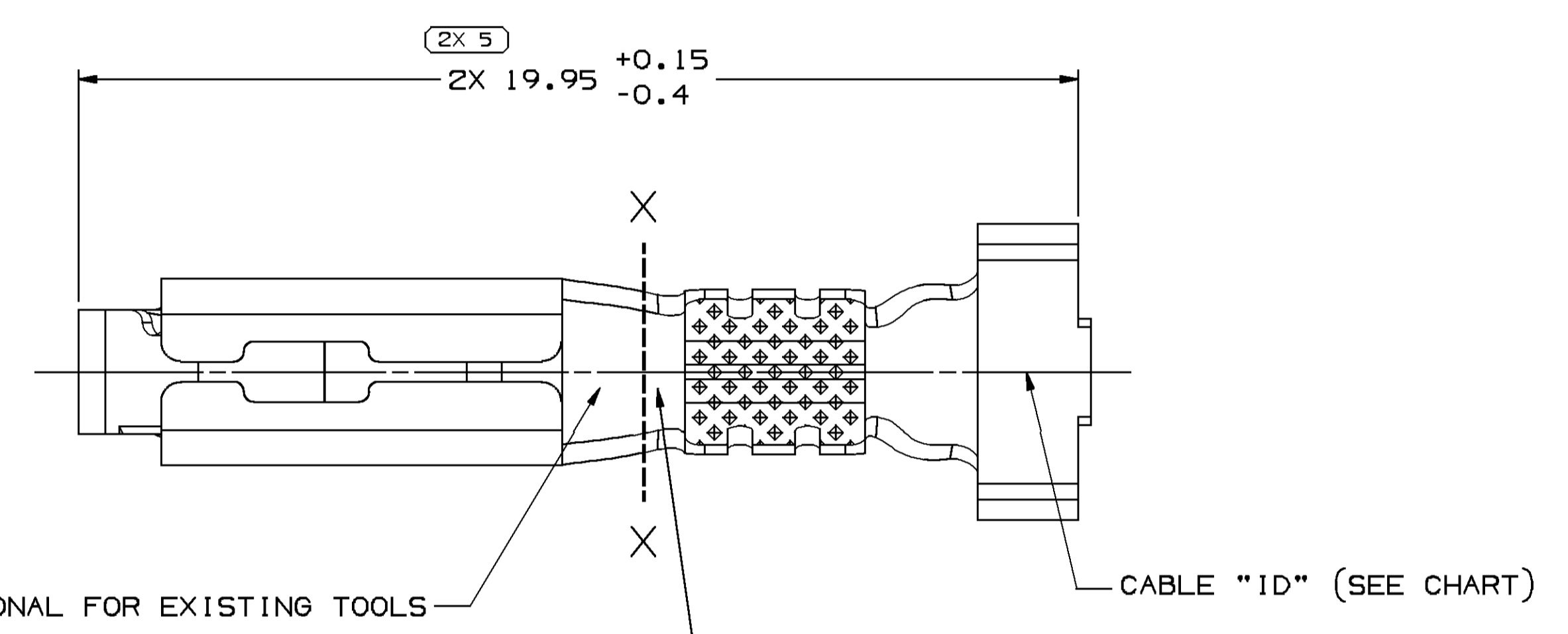

"PED" OPTIONAL FOR EXISTING TOOLS

CABLE "ID" (SEE CHART)

STAMP DIE ID "PXX" IN THIS AREA (0.6) CHARACTERS XX DESIGNATES DIE NUMBER LOCATION IS APPROXIMATE

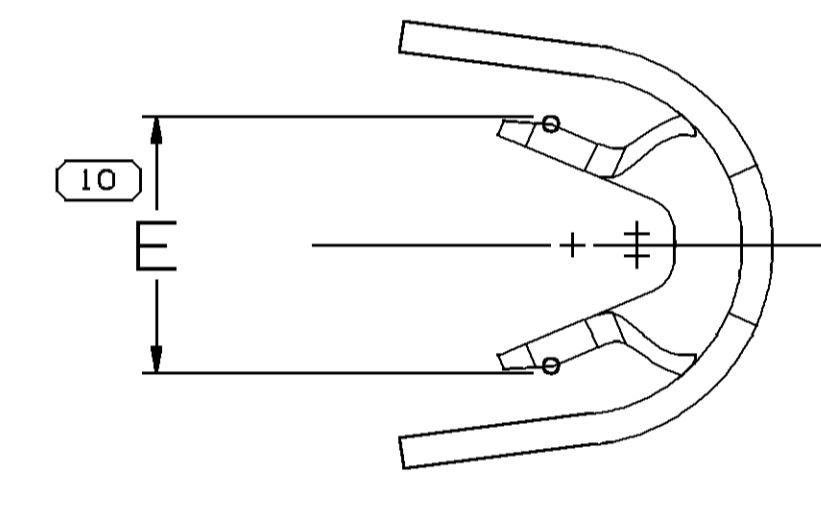

VIEW TO X-X

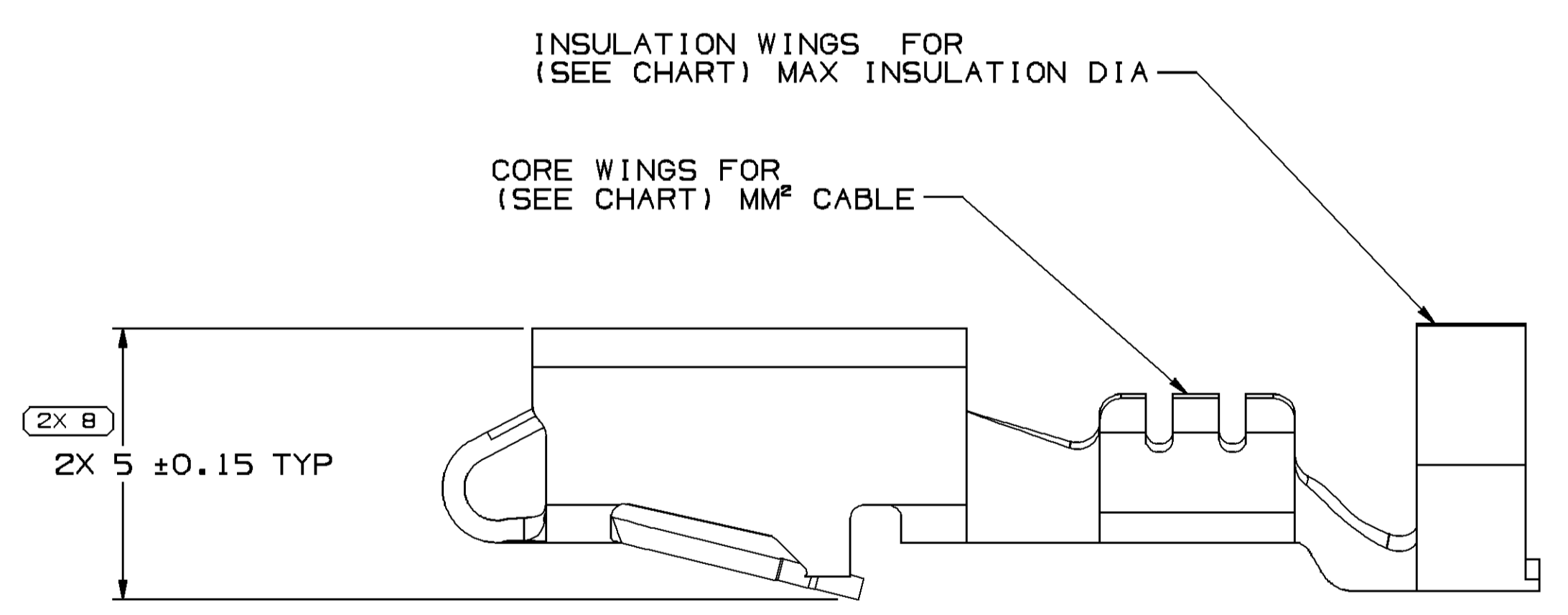

TYPE 101

NOTES

- UNLESS OTHERWISE SPECIFIED AND/OR INDICATED: DIMENSIONS ARE TO FACE OF VIEW SHOWN AND AUTOMATICALLY ROUNDED BY COMPUTER FOR INSPECTION (SEE MATH MODEL FOR PRECISE DIMENSIONS). FOR ALL OTHER DIMENSIONS NOT SHOWN BUT REQUIRED FOR TOOL BUILD, SEE MATH MODEL FOR PRECISE TOOL PATH DATA.
- R 0.4 PERMISSIBLE ON ALL "SHARP" CORNERS
- RECOMMENDED MATING BLADE 2.8 X 0.81.
- TERMINALS TO CRIMP AROUND AND RETAIN CAVITY SEAL 12015323 OR EQUIVALENT.
- "PXX" INDICATES "P" PLUS LAST TWO DIGITS OF MAKE SERIES NUMBER (PO1, PO2, PO3, ETC.).
- DO NOT PROBE, TEST OR OTHERWISE CONTACT THE INTERIOR REGION (THE SPRING OR ANY MOVING PART) OF THIS TERMINAL. SEVERE DAMAGE CAN OCCUR, COMPROMISING THE PERFORMANCE OF THE ELECTRICAL INTERFACE.
- FOR TERMINALS PACKAGED & STORED IN THE APPROVED MANNER, TARNISH ON SILVER PLATED SURFACES WILL NOT AFFECT THE PERFORMANCE OF THE PART.

PART NO	REV	MAT'L SIZE	SPEC	PART NO	REV/N/P	MAT'L SPEC	SIZE (MM²)	DIA	ID	TYPE	E	
-	-	0.406 X 30.56	-	12176390	AB	-	AG PLATED COPPER ALLOY	0.35-0.5	0.35-0.5	21	103	2.4±0.2
-	-	-	-	12176389	A9	-	AG PLATED COPPER ALLOY	0.8-1	2.03-3.12	19	101	3.2±0.4
-	-	0.406 X 30.56	-	33231919	O1	-	AG PLATED COPPER ALLOY	1-2	2.48-3.05	15	103	3.7±0.4
-	-	0.406 X 30.56	-	12176388	AB	-	AG PLATED COPPER ALLOY	2-3	2.45-3.80	13	103	4±0.4
-	-	0.406 X 30.56	-	12176387	AB	-	AG PLATED COPPER ALLOY	5	3.49-3.65	12	103	4.6±0.4
-	-	0.406 X 30.56	-	12129493	CB	-	TIN PLATED COPPER ALLOY	2-3	2.45-3.80	13	103	4±0.4
-	-	0.406 X 30.56	-	12084201	E11	-	TIN PLATED COPPER ALLOY	0.35-0.5	1.84-2.51	21	101	2.4±0.2
-	-	0.406 X 30.56	-	12077413	E11	-	TIN PLATED COPPER ALLOY	3	3.49-3.65	12	103	4.6±0.4
-	-	0.406 X 30.56	-	12077412	E9	-	TIN PLATED COPPER ALLOY	1-2	2.48-3.05	15	103	3.7±0.4
-	-	0.406 X 30.56	-	12077411	E11	-	TIN PLATED COPPER ALLOY	0.5-0.8-1.0	2.03-3.12	19	101	3.2±0.4
-	-	0.406 X 32.54	-	12045639	DB	-	P1519027 425 TIN BRS EX HD SN PLTD	3	3.49-3.65	12	102	4.6±0.4
-	-	0.406 X 32.54	-	12034454	FB	-	P1519027 425 TIN BRS EX HD SN PLTD	1-2	2.48-3.05	15	102	3.7±0.4
-	-	0.406 X 32.54	-	12026648	HB	-	P1519027 425 TIN BRS EX HD SN PLTD	0.5-0.8	2.03-3.12	19	101	3.2±0.4

DELPHI
DELPHI PACKARD ELECTRICAL/ELECTRONIC ARCHITECTURE
WARREN, OH
COPYRIGHT 1998 DELPHI CORPORATION AND/OR ITS AFFILIATES. ALL RIGHTS RESERVED.
THIS DRAWING IS THE PROPERTY OF DELPHI CORPORATION AND CONTAINS DELPHI CONFIDENTIAL INFORMATION. THE REPRODUCTION, DISTRIBUTION AND UTILIZATION OF THIS DOCUMENT OR ITS CONTENTS OR DATA, AS WELL AS COMMUNICATION OF ANY CONTENT TO OTHERS, WITHOUT EXPRESS AUTHORIZATION, IS PROHIBITED.

DATE: 16JUL98
OR: JORGE IBARRA
APV02: OSCAR OCHOA
APV03: O. GALLEGOS
APV04:

THIS DOCUMENT IS IN ACCORDANCE WITH ASME Y14.5M-1994 AS INDICATED BY THE DIMENSIONAL DIMENSIONS AND TOLERANCES. SEPARATE PATTERNS OF FEATURES MAY BE SHOWN SEPARATELY. REFERENCES TO THIS DOCUMENT SHALL BE TO THE ORIGINAL DRAWING AND NOT TO THIS REPRODUCTION.

UNLESS OTHERWISE SPECIFIED
ALL DIMENSIONS ARE IN MILLIMETERS

REFERENCE: UNLESS OTHERWISE SPECIFIED

1 PROCESS SENSITIVE DIMENSION
DIMENSIONS ENCLOSED IN () INDICATE REFERENCE DIMENSIONS AND NO TOLERANCE LIMITS ARE ESTABLISHED

THIRD ANGLE PROJECTION
DO NOT SCALE
USE MATH DATA

DRAWING NUMBER: 12089195
SHEET NO: 1 OF 1
REV: R 08