



96kHz DIGITAL AUDIO INTERFACE TRANSMITTER

- MONOLITHIC DIGITAL AUDIO INTERFACE TRANSMITTER
- 3.3V SUPPLY VOLTAGE
- SUPPORTS:
 - AES/EBU, IEC 958,
 - S/PDIF, & EIAJ CP-340
 - Professional and Consumer Formats
- PARITY BITS AND CRC CODES GENERATED
- TRANSPARENT MODE ALLOWS DIRECT CONNECTION OF STA020D AND STA120

DESCRIPTION

The STA020D is a monolithic CMOS device which encodes and transmits audio data according to the AES/EBU, IEC 958, S/PDIF, & EIAJ CP-340 interface standards. It supports 96kHz sample rate operation

The STA020D accepts audio and digital data which is then multiplexed, encoded and driven onto a cable.

The audio serial port is double buffered and capa-



ble of supporting a wide variety of formats.

The STA020D multiplexes the channel, user, and validity data directly from serial input pins with dedicated input pins for the most important channel status bits.

BLOCK DIAGRAM

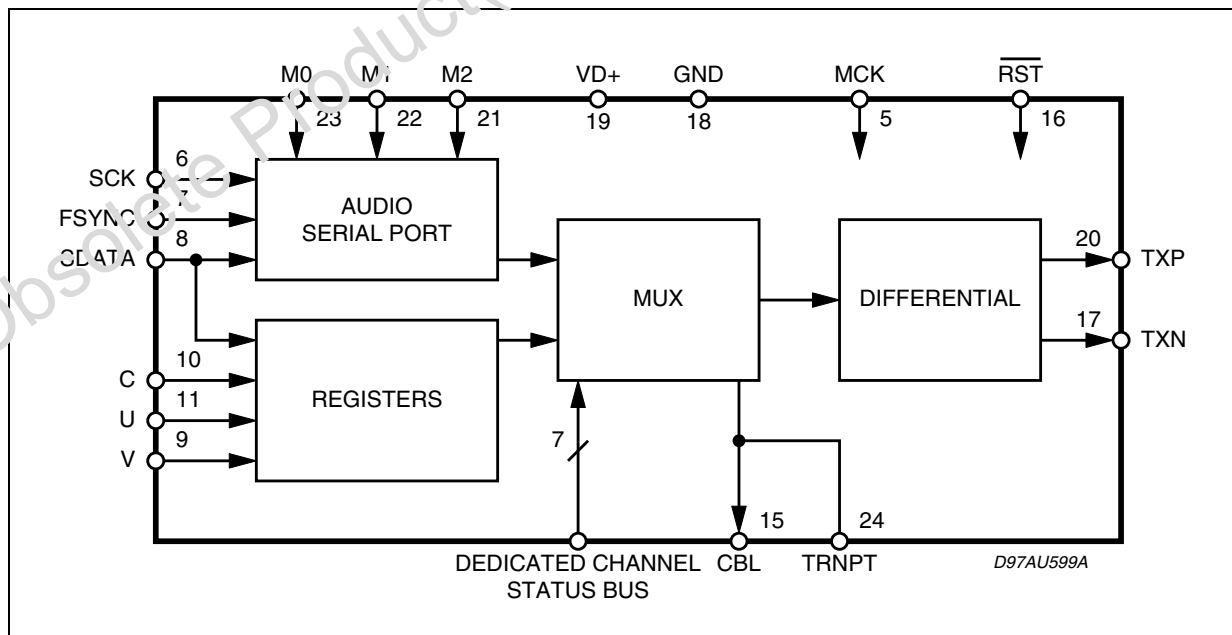

STA020

ABSOLUTE MAXIMUM RATINGS

Symbol	Parameter	Value	Unit
V _{D+}	DC Power Supply	4	V
V _{IND}	Digital Input Voltage	-0.3 to V _{D+} 0.3	V
T _{amb}	Ambient Operating Temperature (power applied)	-20 to +85	°C
T _{stg}	Storage Temperature	-40 to 150	°C

RECOMMENDED OPERATING CONDITIONS (GND = 0V; all voltages with respect to ground)

Symbol	Parameter	Test Condition	Min.	Typ.	Max.	Unit
V _{D+}	DC Voltage		3	3.3	3.6	V
T _{amb}	Ambient Operating Temp.		0	25	70	°C

PIN CONNECTIONS (Top view)

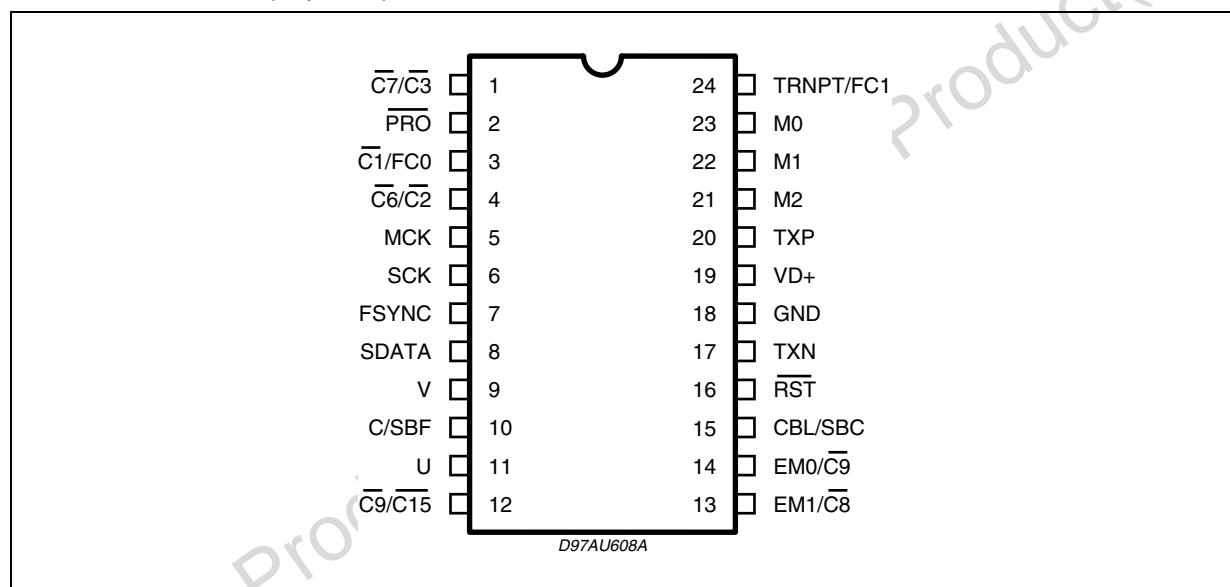

PIN DESCRIPTION

N°	Pin	Function
Power Supply Connections		
18	GND	Ground.
19	VD+	Positive Digital Power. Nominally +3.3V.
Audio Input Interface		
6	SCK	Serial Clock. Serial clock for SDATA pin which can be configured (via the M0, M1 and M2 pins) as an input or output and can sample data on the rising or falling edge. As an output, SCK will contain 32 clocks for every audio sample.

PIN DESCRIPTION (continued)

N°	Pin	Function
7	FSYNC	Frame Sync. Delineates the serial data and may indicate the particular channel, left or right and may be an input or output. The format is based on M0, M1 and M2 pins.
8	SDATA	Serial Data. Audio data serial input pin.
21, 22,23	M0, M1, M2	Serial Port Mode Select. Selects the format of FSYNC and the sample edge of SCK with respect to SDATA.
Control Pins		
1	$\overline{C7/C3}$	Channel Status Bit 7/Channel Status Bit 3 In professional mode, C7 is the inverse of channel status bit 7. In consumer mode, C3 is the inverse of channel status bit 3, $\overline{C7/C3}$ are ignored in Transparent Mode.
2	\overline{PRO}	Professional/Consumer Select. Selects between professional mode (\overline{PRO} low) and consumer mode (\overline{PRO} high). This pin defines the functionality of the channel status parallel pins. \overline{PRO} is ignored in Transparent Mode.
3	$\overline{C1/FC0}$	Channel Status Bit 1/Frequency Control 0. In professional mode, C1 is the inverse of channel status bit 1. In consumer mode, FC0 and FC1 are encoded versions of channel status bits 24 and 25 (bits 0 and 1 of byte 3). When FC0 and FC1 are both high, CD mode is selected. $\overline{C1/FC0}$ are ignored in Transparent Mode.
4	$\overline{C6/C2}$	Channel Status Bit 6/Channel Status Bit 2. In professional mode, C6 is the inverse of channel status bit 6. In consumer mode, $\overline{C2}$ is the inverse of channel status bit 2. $\overline{C6/C2}$ are ignored in Transparent Mode
9	V	Validity. Validity bit serial input port. This bit is defined as per the digital audio standards wherein V = 0 signifies the audio signal is suitable for conversion to analog. V = 1 signifies the audio signal is not suitable for conversion to analog, i.e. invalid.
10	C/SBF	Channel Status Serial Input/Subcode Frame Clock. In professional and consumer modes this pin is the channel status serial input port. In CD mode this pin inputs the CD subcode frame clock.
11	U	User Bit. User bit serial input port.
12	$\overline{C9/C15}$	Channel Status Bit 9/Channel Status Bit 15. In professional mode, $\overline{C9}$ is the inverse of channel status bit 9 (bit 1 of byte 1). In consumer mode, $\overline{C15}$ is the inverse of channel status bit 15 (bit 7 of byte 1). $\overline{C9/C15}$ are ignored in Transparent Mode.
13	EM1/ $\overline{C8}$	Emphasis 1/Channel Status Bit 8. In professional mode, EM0 and EM1 encode channel status bits 2, 3 and 4. In consumer mode, $\overline{C8}$ is the inverse of channel status bit 8 (bit 0 of byte 1). EM1/ $\overline{C8}$ are ignored in Transparent Mode.
14	EM0/ $\overline{C9}$	Emphasis 0/Channel Status Bit 9. In professional mode, EM0 and EM1 encode channel status bits 2, 3 and 4. In consumer mode, $\overline{C9}$ is the inverse of channel status bit 9 (bit 1 of byte 1). EM0/ $\overline{C9}$ are ignored in Transparent Mode.
15	CBL/SBC	Channel Status Block Output/Subcode Bit Clock. In professional and consumer modes, the channel status block output is high for the first 15 bytes of channel status. In CD mode, this pin outputs the subcode bit clock.
16	\overline{RST}	Master Reset. When low, all internal counters are reset.

STA020

PIN DESCRIPTION (continued)

N°	Pin	Function
24	TRNPT/FC1	Transparent Mode/Frequency Control 1. In professional mode, setting TRNPT low selects normal operation & CBL is an output. Setting TRNPT high, allows the STA020D to be connected directly to an STA120. In transparent mode, CBL is an input & MCK must be at 256 Fs. In consumer mode, FC0 and FC1 are encoded versions of channel status bits 24 and 25. When FC0 and FC1 are both high, CD mode is selected.
Transmitter Interface		
5	MCK	Master Clock. Clock input at 128x the sample frequency which defines the transmit timing. In transparent mode MCK must be 256 Fs.
20, 17	TXP, TXN	Differential Line Drivers.

DIGITAL CHARACTERISTICS ($T_{amb} = 25^{\circ}\text{C}$; $V_{D+} = 3.3\text{V } 10\%$)

Symbol	Parameter	Test Condition	Min.	Typ.	Max.	Unit
V_{IH}	High-Level Input Voltage		2.0		$V_{DD}+0.3$	V
V_{IL}	Low-Level Input Voltage		-0.3		+0.8	V
V_{OH}	High-Level Output Voltage	$I_O = 200\mu\text{A}$	$V_{DD}-1.0$			V
V_{OL}	Low-Level Output Voltage	$I_O = 3.2\text{mA}$			0.4	V
I_{in}	Input Leakage Current			1.0	10	A
MCK	Master Clock frequency	(Note 1)			26	MHz
	Master Clock Duty Cycle	(high time/cycle time)	40		60	%

Note 1: MCK must be 128x the input word rate, except in Transparent Mode where MCK is 256x the input word rate.

Figure 1. STA020D Professional & Consumer Modes Typical Connection Diagram.

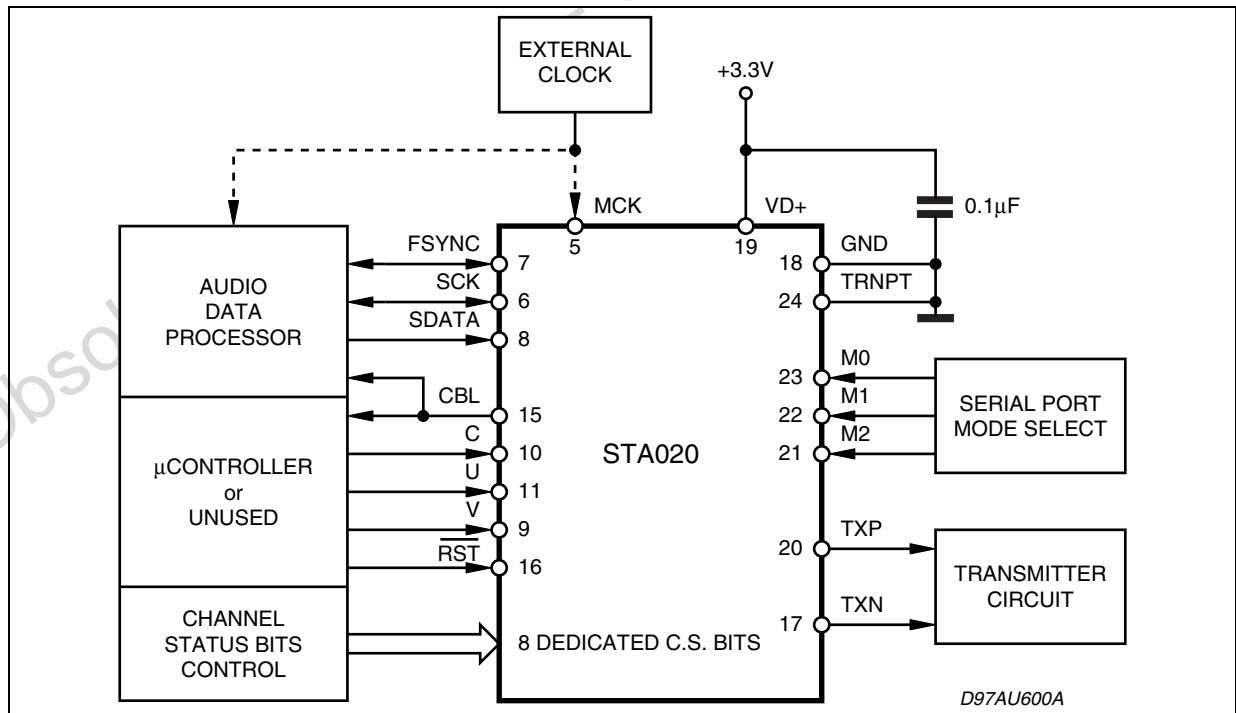
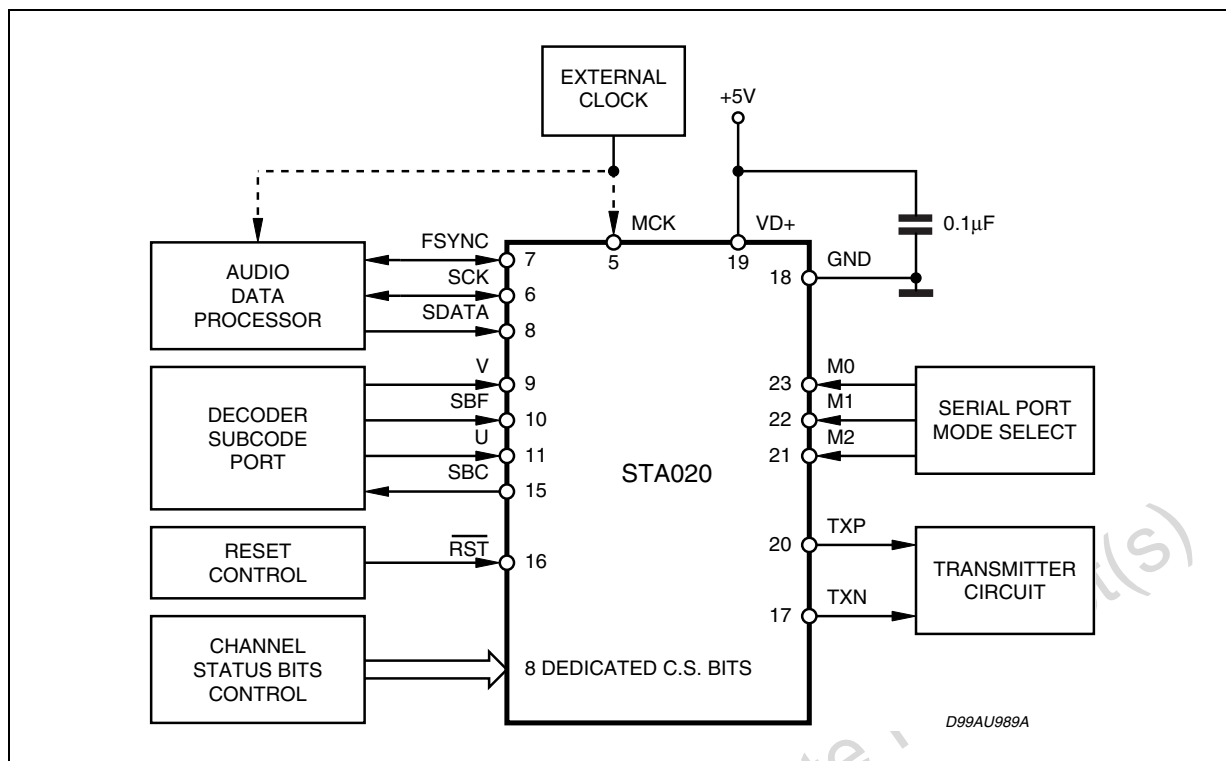

Figure 2. STA020D Typical Connection Diagram.



GENERAL DESCRIPTION

The STA020D is a monolithic CMOS circuit that encodes and transmits audio and digital data according to the AES/EBU, IEC 958, S/PDIF, and EIAJ CP-340 interface standards. The chip accepts audio and control data separately; multiplex and biphase-mark encode the data internally and drive it, directly or through a transformer, to a transmission line.

The STA020D has dedicated pins for the most important control bits and a serial input port for the C, U and V bits.

Line Drivers

The differential line drivers for STA020D are low skew, low impedance, differential outputs capable of driving 110Ohm transmission lines. (RS422 line driver compatible).

They can also be disabled by resetting the device (RST = low).

STA020D DESCRIPTION

The STA020D accepts 16 to 24-bit audio samples through a serial port configured in one of seven formats; provides several pins dedicated to particular channel status bits and allows all channel status, user and validity bits to be serially input through port pins. This data is multiplexed, the parity bit is generated and the bit stream is biphase-mark encoded and driven through an RS422 line driver.

The STA020D operates as a professional or consumer interface transmitter selectable by pin 2, \overline{PRO} . As a professional interface device, the dedicated channel status input pins are defined according to the professional standard, and the CRC code (C.S. byte 23) can be internally generated.

As a consumer device, the dedicated channel status input pins are defined according to the consumer standard. A submode provided under the consumer mode is compact disk, CD, mode. When transmitting data from a compact disk, the CD subcode port can accept CD subcode data, extract channel status in-

formation from it, and transmit it as user data.

The master clock , MCK, controls timing for the entire chip and must be 128xFs. As an example, if stereo data is input to the STA020D at 44.1kHz, MCK input must be 128 times that or 5.6448MHz.

Audio Serial Port

The audio serial port is used to enter audio data and consists of three pins: SCK, SDATA and FSYNC, SCK clocks in SDATA, which is double buffered, while FSYNC delineates the audio samples and may indicate the particular channel, left or right. To support many different interfaces, M2, M1 and M0 select one of seven different formats for the serial port. The coding is shown in Table 3 while the formats are shown in Figure 3.

Format 0 and 1 are designed to interface with Crystal ADCs. Format 2 communicates with Motorola and TI DSPs. Format 3 is reserved. Format 4 is compatible with the I2S standard. Formats 5 and 6 make the STA020D look similar to existing 16- and 18-bit DACs and interpolation filters. Format 7 is an MSB-last format and is conducive to serial arithmetic. SCK and FSYNC are outputs in Format 0 and inputs in all other formats. In Format 2, the rising edge of FSYNC delineates samples and the falling edge must occur a minimum of one bit period before or after the rising edge. In all formats except 2, FSYNC contains left/right information requiring both edges of FSYNC to delineate samples. Formats 5 and 6 require a minimum of 16- or 18-bit audio words respectively. In all formats other than 5 and 6, the STA020D can accept any word length from 16 to 24 bits by adding leading zeros in format 7 and trailing zeros in the other formats, or by restricting the number of SCK periods between active edges of FSYNC to the sample word length.

FSYNC must be derived from MCK, either through a DSP using the same clock or using counters. If SFYNC moves (jitters) with respect to MCK by four MCK periods, the internal counters and CBL may be reset.

Table 1. Audio Port Modes

M2	M1	M0	Format
0	0	0	0 - FSYNC & SCK Output
0	0	1	1 - Left/Right, 16-24 Bits
0	1	0	2 - Word Sync, 16-24 Bits
0	1	1	3 - Reserved
1	0	0	4 - Left/Right, I ² S Compatible
1	0	1	5 - LSB Justified, 16 Bits
1	1	0	6 - LSB Justified, 18 Bits
1	1	1	7 - MSB Last, 16-24 Bits

Figure 3. Audio Serial Port Formats.

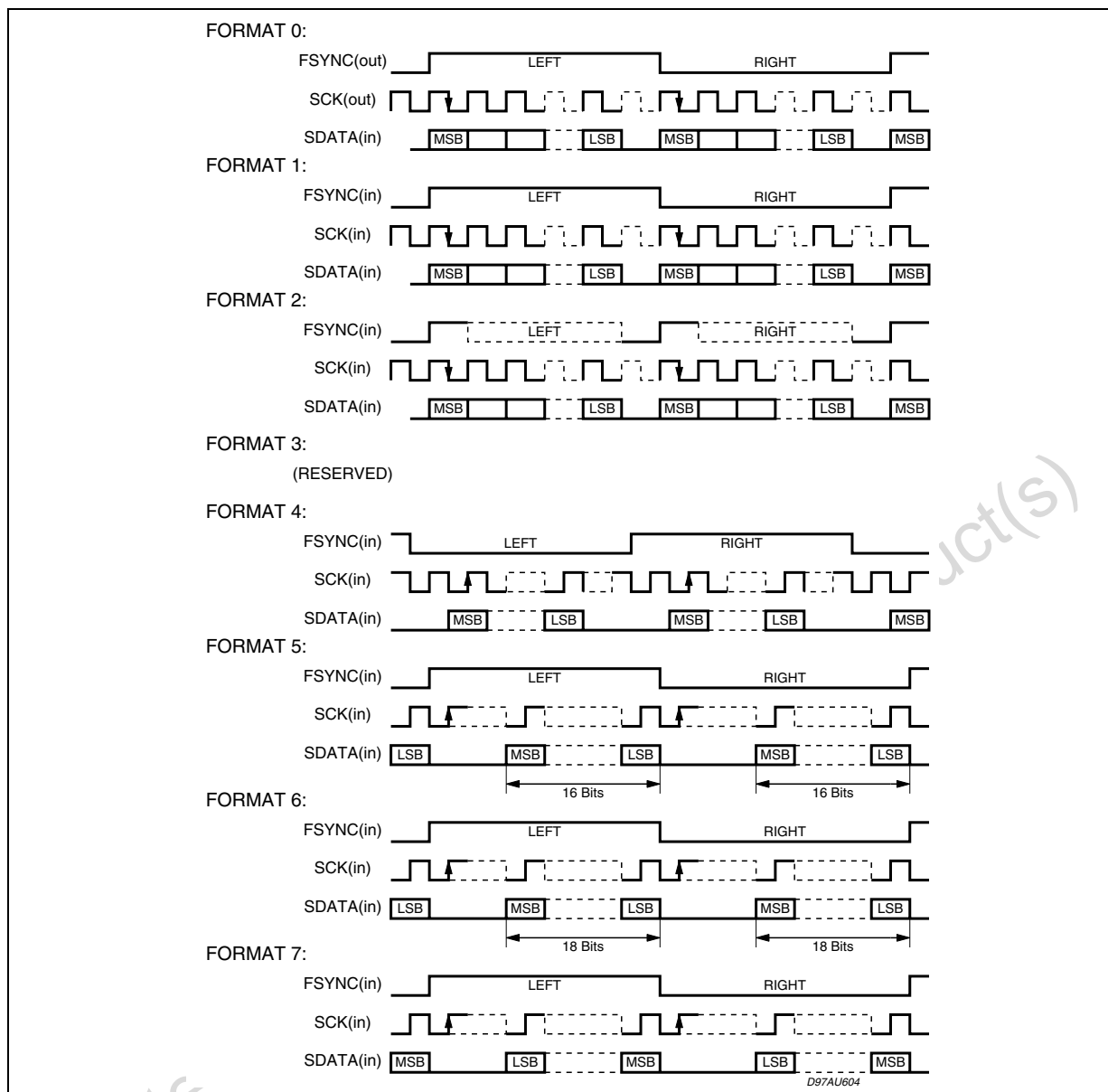

C, U, V Serial Port

The serial input pins for channel status (C), user (U), and validity (V) are sampled during the first bit period after the active edge of FSYNC for all formats except Format 4. Format 4 is sampled during the second bit period (coincident with the MSB). In Figure 3, the arrows on SCK indicate when the C, U, and V bits are sampled. The C, U, and V bits are transmitted with the audio sample entered before FSYNC edge that sampled it. The V bit, as defined in the audio standards, is set to zero to indicate the audio data is suitable for conversion to analog. Therefore, when the audio data is errored, or the data is not audio, the V bit should be set high. The channel status serial input pin (C) is not available in consumer mode when the CD subcode port is enabled (FC1 = FC0 = high). Any channel status data entered through the channel status serial input (C) is logically OR'ed with the data entered through the dedicated pins or internally generated.

RST and CBL (TRNPT is low)

When \overline{RST} goes low, the differential line drivers are set to ground. In order to properly synchronize the ST020 to the audio serial port, the transmit timing counters, which include CBL, are not enabled after \overline{RST} goes high until eight and one half SCK periods after reset is exited) of FSYNC. When FSYNC is configured as a left/right signal (all defined formats except 2), the counters and CBL are not enabled until the right sample is being transmitted). This guarantees that channel A is left and channel B is right as per the digital audio interface specs.

As shown in Figure 4, channel block start output (CBL), can assist in serially inputting the C, U and V bits as CBL goes high one bit period before the first bit of the preamble of the first sub-frame of the channel status block is transmitted. This sub-frame contains channel status byte 0, bit 0. CBL returns low one bit period before the start of the frame that contains bit 0 of channel status byte 16. CBL is not available when the CD subcode port is enabled.

Figure 4 illustrates timing for stereo data input on the audio port. Notice how CBL rises while the right channel data (Right 0) is input, but the previous left channel (Left 0) is being transmitted as the first sub-frame of the channel status block (starting with preamble Z). The C, U, and V input ports only need to be valid for a short period after FSYNC changes. A sub-frame includes one audio sample while a frame includes a stereo pair. A channel status (C.S.) block contains 24 bytes of channel status and 384 audio samples (or 192 stereo pairs, or frames, of samples). Figure 4 shows the CUV ports as having left and right bits (e.g. CUV0L, CUV0R). Since the C.S. block is defined as 192 bits, or one bit per frame, there are actually 2 C.S. blocks, one for channel A (left) and one for channel B (right). When inputting stereo audio data, both blocks normally contain the same information, so C0L and C0R from the input port pin are both channel status bit 0 of byte 0, which is defined as professional/consumer. These first two bits from the port, C0L and C0R, are logically OR'ed with the inverse \overline{PRO} , since \overline{PRO} is a dedicated channel status pin defined as C.S. bit 0.

Also, in professional mode, $\overline{C1}$, $\overline{C6}$, $\overline{C7}$ and $\overline{C9}$ are dedicated C.S. pins. The inverse of C1 is logically OR'ed with channel status input ports bits C1L and C1R. In similar fashion, $\overline{C6}$, $\overline{C7}$ and $\overline{C9}$ are OR'ed with their respective input bits. Also, the C bits in CUV128L and CUV128R are both channel status block bit 128, which is bit 0 of channel status byte 16.

Figure 4. CBL and Transmitter Timing.

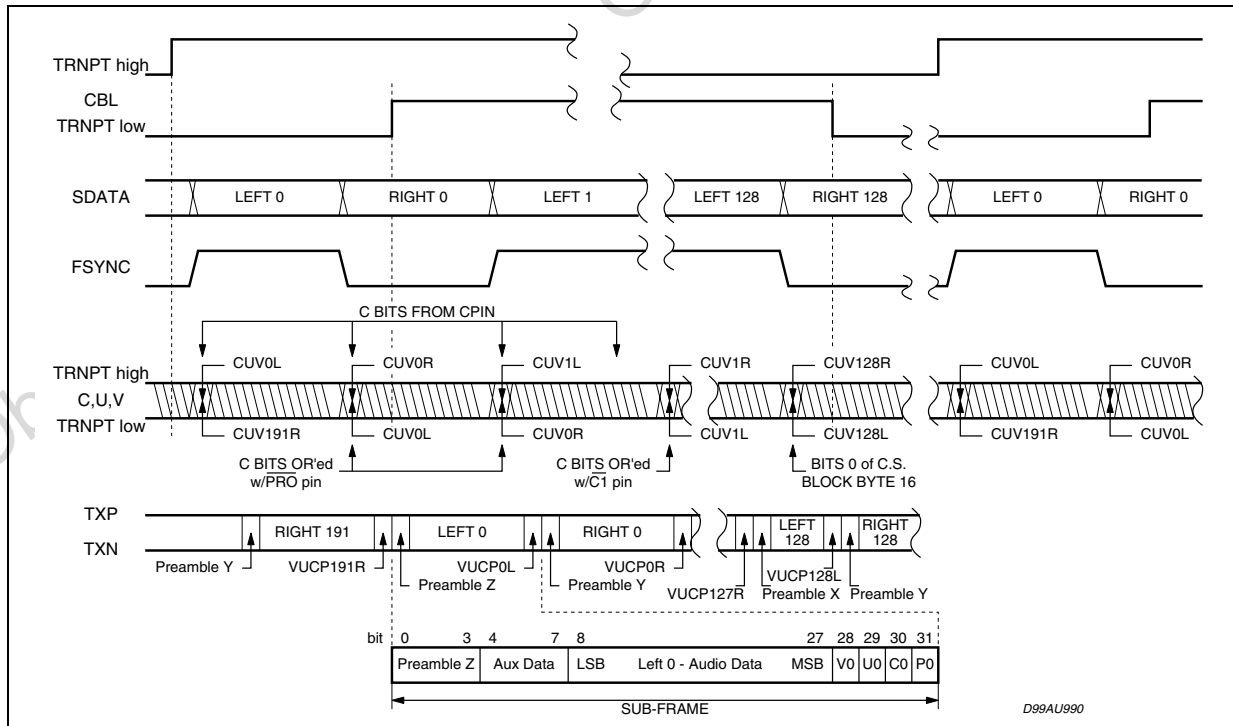

Transparent Mode

In certain applications it is desirable to receive digital audio data with the STA120 and retransmit it with the STA020D. In this case, channel status, user and validity information must pass through unaltered. For studio environments, AES recommends that signal timing synchronization be maintained throughout the studio. Frame synchronization of digital audio signals input to and output from a piece of equipment must be within $\pm 5\%$.

The transparent mode of the STA020D is selected by setting TRNPT, pin 24, high. In this mode, the CBL pin becomes an input, allowing direct connection of the outputs of the STA120 to the inputs of the STA020D as shown in Figure 18. The transmitter and receiver are synchronized by the FSYNC signal. CBL specifies the start of a new channel status block boundary, allowing the transmit block structure to be slaved to the block structure of the receiver.

In the transparent mode, C, U and V are now transmitted with the current audio sample as shown in Figure 5 (TRNPT high) and the dedicated channel status pins are ignored.

When FSYNC is a word clock (Format 2), CBL is sampled when left C, U, V are sampled. When FSYNC is Left/Right, CBL is sampled when left C, U, V are sampled. The channel status block boundary is reset when CBL transitions from low to high (based on two successive samples of CBL). MCK for the STA020D is normally expected to be 128 times the sample frequency, in the transparent mode MCK must be 256 Fs.

Professional Mode

Setting \overline{PRO} low places the STA020D in professional mode as shown in Figure 6. In professional mode, channel status bit 0 is transmitted as a one and bits 1, 2, 3, 4, 6, 7 and 9 can be controlled via dedicated pins. The pins are actually the inverse of the identified bit.

For example, tying the $\overline{C1}$ pin low places a one in channel status bit 1. As shown in the application Note, Overview of AES/EBU Digital Audio Interface Data Structures, $\overline{C1}$ indicates audio/non-audio; $\overline{C6}$ and $\overline{C7}$ determine the sample frequency and $\overline{C9}$ allows the encoded channel mode to be stereophonic. EM1 and EM0 determine emphasis and encode $\overline{C2}$, $\overline{C3}$, $\overline{C4}$ as shown in Table 2. The dedicated channel status pins are read at the appropriate time and are logically OR'ed with data input on the channel status port, C. In Transparent Mode, these dedicated channel status pins are ignored and channel status bits are input at the C pin.

Consumer Mode

Setting \overline{PRO} high places the STA020D in consumer mode which redefines the pins as shown in Figure 7. In consumer mode, channel status bit 0 is transmitted as a zero and channel status bits 2, 3, 8, 9, 15, 24 and 25 are controlled via dedicated pins.

The pins are actually the inverse of the bit so if pin $\overline{C2}$ is tied high, channel status bit 2 will be transmitted as a zero. Also, FC0 and FC1 are encoded versions of channel status bits 24 and 25, which define the sample frequency.

When FC0 and FC1 are both high, the part is placed in a CD submode which activates the CD subcode port. This submode is described in detail in the next section. Table 3 describes the encoding of C24 and C25 through the FC1 and FC0 pins. According to AES/EBU standards, C2 is copy prohibit/permit. C3 specifies pre-emphasis, C8 and C9 define the category code and C15 identifies the generation status of the transmitted material (i.e. first generation, second generation).

Table 2. Emphasis Encoding

EM1	EM0	C2	C3	C4
0	0	1	1	1
0	1	1	1	0
1	0	1	0	0
1	1	0	0	0

Table 3. Sample Frequency Encoding

FC1	FC0	C24	C25	Comments
0	0	0	0	44.1kHz
0	1	0	1	48kHz
1	0	1	1	32kHz
1	1	0	0	44.1kHz, CD Mode

Figure 5. Transparent Mode Interface.

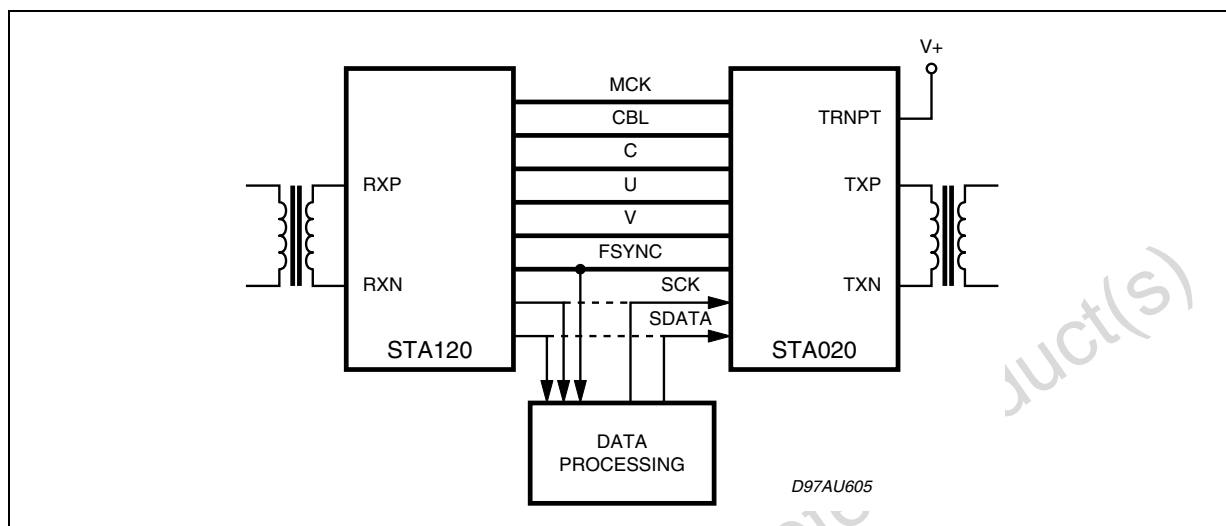

Figure 6. Block Diagram - Professional Mode

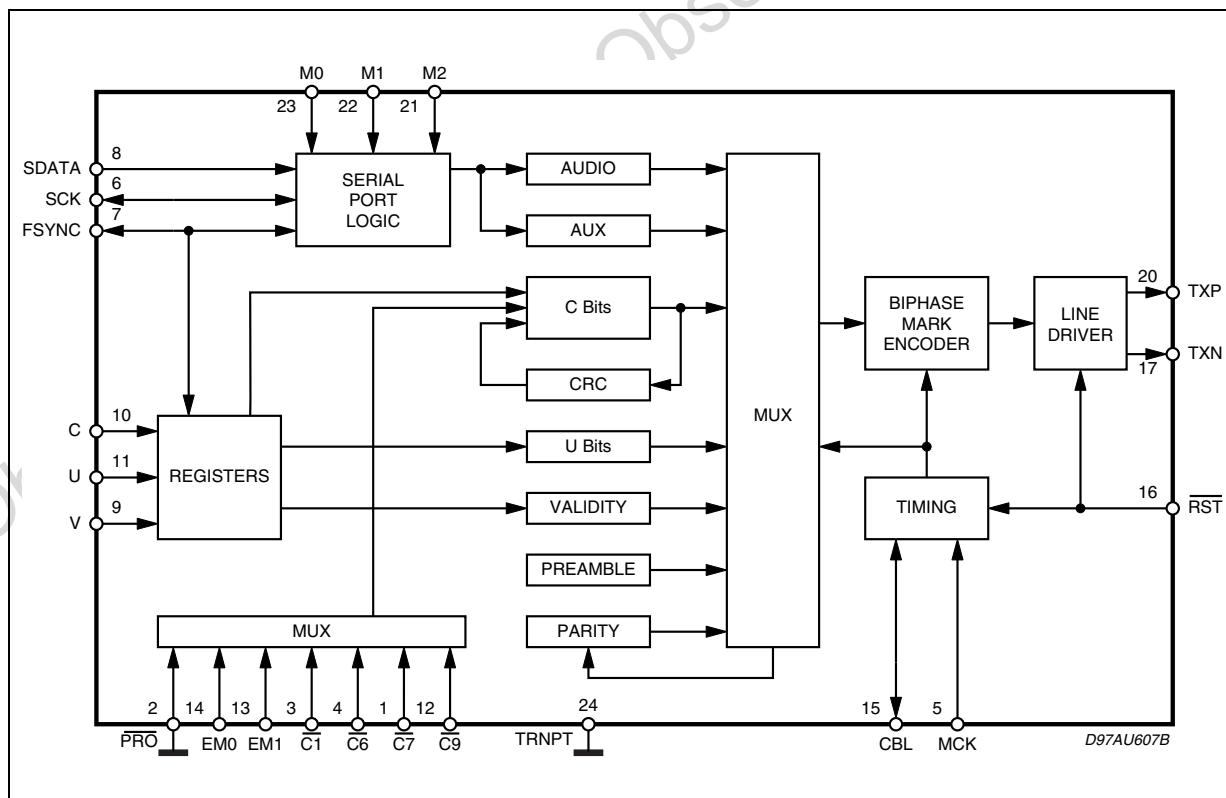
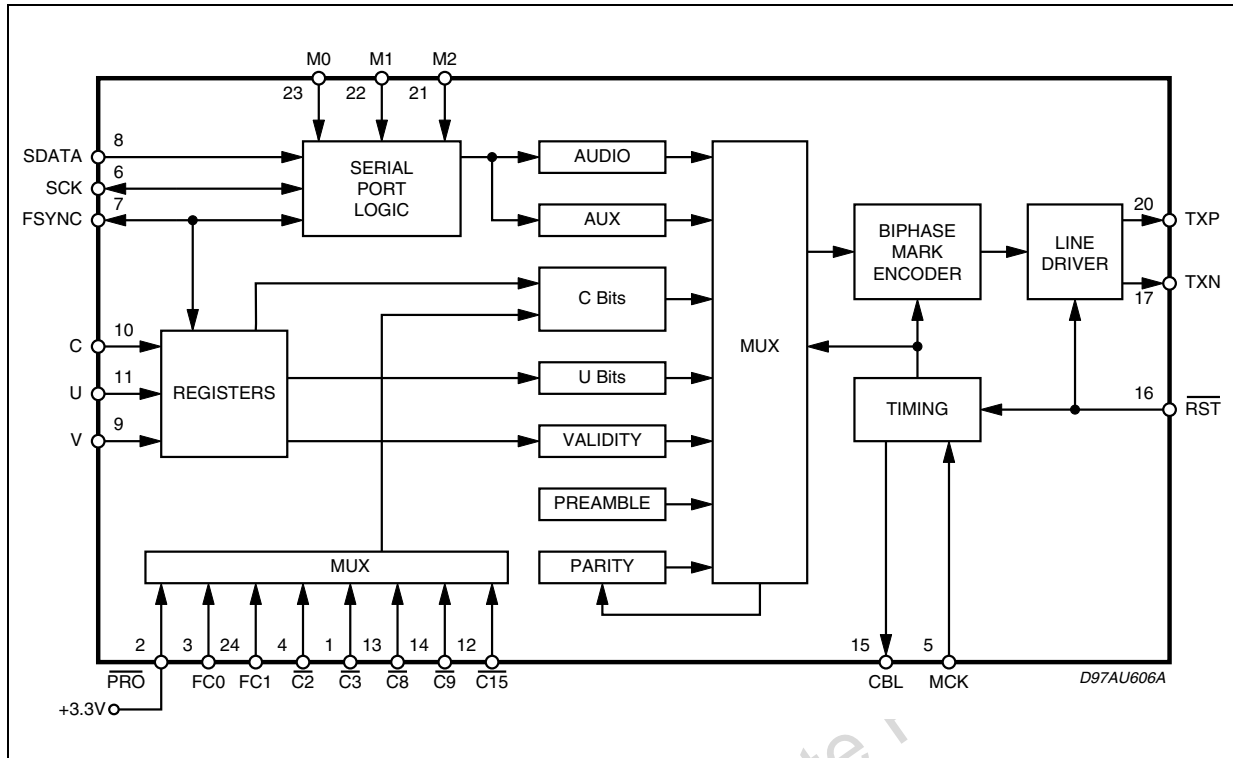

Figure 7. Block Diagram - Consumer Mode



Obsolete Product(s) - Obsolete

STA020

DIM.	mm			inch		
	MIN.	TYP.	MAX.	MIN.	TYP.	MAX.
A	2.35		2.65	0.093		0.104
A1	0.10		0.30	0.004		0.012
B	0.33		0.51	0.013		0.200
C	0.23		0.32	0.009		0.013
D (1)	15.20		15.60	0.598		0.614
E	7.40		7.60	0.291		0.299
e		1.27			0.050	
H	10.0		10.65	0.394		0.419
h	0.25		0.75	0.010		0.030
L	0.40		1.27	0.016		0.050
k	0° (min.), 8° (max.)					
ddd			0.10			0.004

(1) "D" dimension does not include mold flash, protusions or gate burrs. Mold flash, protusions or gate burrs shall not exceed 0.15mm per side.

OUTLINE AND MECHANICAL DATA

Weight: 0.60gr

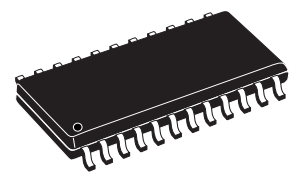

SO24

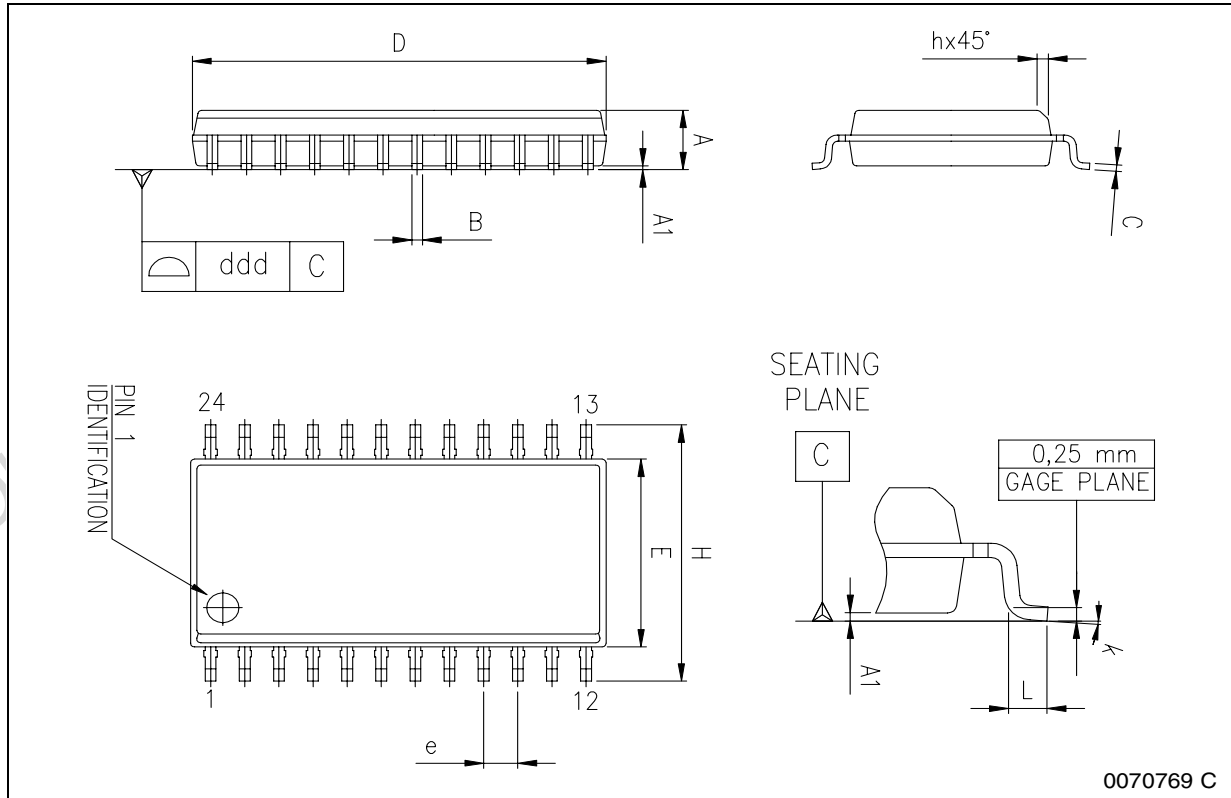

0070769 C



REVISION HISTORY

Date	Revision	Changes
14-Oct-2002	5	Technical Migration from ST-PRESS to EDOCS
26-Apr-2010	6	Major revision for revalidation process

Obsolete Product(s) - Obsolete Product(s)

Please Read Carefully:

Information in this document is provided solely in connection with ST products. STMicroelectronics NV and its subsidiaries ("ST") reserve the right to make changes, corrections, modifications or improvements, to this document, and the products and services described herein at any time, without notice.

All ST products are sold pursuant to ST's terms and conditions of sale.

Purchasers are solely responsible for the choice, selection and use of the ST products and services described herein, and ST assumes no liability whatsoever relating to the choice, selection or use of the ST products and services described herein.

No license, express or implied, by estoppel or otherwise, to any intellectual property rights is granted under this document. If any part of this document refers to any third party products or services it shall not be deemed a license grant by ST for the use of such third party products or services, or any intellectual property contained therein or considered as a warranty covering the use in any manner whatsoever of such third party products or services or any intellectual property contained therein.

UNLESS OTHERWISE SET FORTH IN ST'S TERMS AND CONDITIONS OF SALE ST DISCLAIMS ANY EXPRESS OR IMPLIED WARRANTY WITH RESPECT TO THE USE AND/OR SALE OF ST PRODUCTS INCLUDING WITHOUT LIMITATION IMPLIED WARRANTIES OF MERCHANTABILITY, FITNESS FOR A PARTICULAR PURPOSE (AND THEIR EQUIVALENTS UNDER THE LAWS OF ANY JURISDICTION), OR INFRINGEMENT OF ANY PATENT, COPYRIGHT OR OTHER INTELLECTUAL PROPERTY RIGHT.

UNLESS EXPRESSLY APPROVED IN WRITING BY AN AUTHORIZED ST REPRESENTATIVE, ST PRODUCTS ARE NOT RECOMMENDED, AUTHORIZED OR WARRANTED FOR USE IN MILITARY, AIR CRAFT, SPACE, LIFE SAVING, OR LIFE SUSTAINING APPLICATIONS, NOR IN PRODUCTS OR SYSTEMS WHERE FAILURE OR MALFUNCTION MAY RESULT IN PERSONAL INJURY, DEATH, OR SEVERE PROPERTY OR ENVIRONMENTAL DAMAGE. ST PRODUCTS WHICH ARE NOT SPECIFIED AS "AUTOMOTIVE GRADE" MAY ONLY BE USED IN AUTOMOTIVE APPLICATIONS AT USER'S OWN RISK.

Resale of ST products with provisions different from the statements and/or technical features set forth in this document shall immediately void any warranty granted by ST for the ST product or service described herein and shall not create or extend in any manner whatsoever, any liability of ST.

ST and the ST logo are trademarks or registered trademarks of ST in various countries.

Information in this document supersedes and replaces all information previously supplied.

The ST logo is a registered trademark of STMicroelectronics. All other names are the property of their respective owners.

© 2010 STMicroelectronics - All rights reserved

STMicroelectronics group of companies

Australia - Belgium - Brazil - Canada - China - Czech Republic - Finland - France - Germany - Hong Kong - India - Israel - Italy - Japan - Malaysia - Malta - Morocco - Philippines - Singapore - Spain - Sweden - Switzerland - United Kingdom - United States of America

www.st.com

X-ON Electronics

Largest Supplier of Electrical and Electronic Components

Click to view similar products for [stmicroelectronics](#) manufacturer:

Other Similar products are found below :

[LD29300D2T25R](#) [M24M02-DWMN3TP/K](#) [AI-JTAGOPTO-1](#) [BUV48A](#) [BZW04-15B](#) [LDK320AM33R](#) [SPC564A80CAL176](#)
[SPC56XVTOP-M](#) [STEVAL-ILL076V2](#) [STEVAL-ISA175V1](#) [STEVAL-VNH5050A](#) [STM32F207IGT7](#) [STR91X-SK/RAI](#) [STTH12003TV1](#)
[STVNIM-EVAL](#) [M24C02-FDW6TP](#) [417989F](#) [SG3525A](#) [ST7FLITE25F2M6](#) [STEVAL-ILL079V1](#) [STEVAL-ISF003V1](#) [STL140N4F7AG](#)
[STM32F031F4P7](#) [STM32F071CBU6](#) [STM32F303VBT6](#) [STM32F765ZIT6](#) [STM32PRIM-LABUPG](#) [STM8A128-EVAL](#) [STW56N65DM2](#)
[LD29150DT18R](#) [LF50ABV](#) [P-NUCLEO-IHM002](#) [VIPER38HDTR](#) [VIPER27LD](#) [VIPER16HN](#) [PD57070-E](#) [PD55003-E](#) [EVAL6226QR](#)
[EVAL6227PD](#) [EVAL6228QR](#) [EVALSP1340HDM](#) [EVLVIP16L-4WFL](#) [EV-VN7050AJ](#) [EV-VND5E025AK](#) [EV-VND7030AJ](#) [ANT2-](#)
[M24LR16E](#) [T1610T-8T](#) [STY60NM50](#) [STW23N85K5](#) [STR736FV2T6](#)