

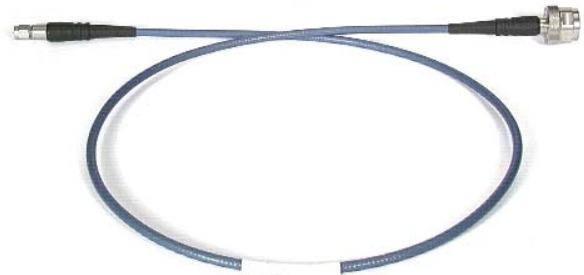

# HUBER+SUHNER® SUCOTEST 18 ASSEMBLY

Part no.: ST-18/SMAm/Nm/36  
 Order no.: 84004594

**SUCOTEST™**  
 be precise.



## Electrical specifications

Impedance	50 Ohms
Operating frequency	18 GHz
Velocity of propagation	77%
Capacitance	87 pF/m (26.5 pF/ft)
Time delay	4.3 ns/m (1.31 ns/ft)
Insulation resistance	$> 5 \times 10^3 \text{ M}\Omega$
Dielectric withstand voltage	2'500 V rms
Screening effectiveness	$> 90 \text{ dB}$

## General specifications

Assembly length	914 mm (36 in.)
Cable diameter	4.6 mm (0.181 in.)
Temperature range	-55°C to +105°C
Preferred bending radius	100 mm (4.0 in.)
Connector retention force	$> 200 \text{ N}$
Recommended mating torque SMA	0.8 Nm... 1.1 Nm (7.1 ... 9.7 in.lbs)
Recommended mating torque N	0.68 Nm... 1.13 Nm (6.0 ... 10.0 in.lbs)
Connector interface SMA	MIL-STD-348A/310
Connector interface N	MIL-STD-348A/304
Weight	90 gram

## Materials and finishes

Cable jacket	FEP, blue
Cable dielectric	LDPTFE
Taper sleeves	Santoprene / black
Marking sleeve	Crosslinked polyolefin/white
Connector contacts	Beryllium-copper, gold plated
Connector insulation	PTFE
Connector body	Stainless steel, passivated
Connector nut	Stainless steel, passivated
Gasket	Silicon rubber

## Dimension

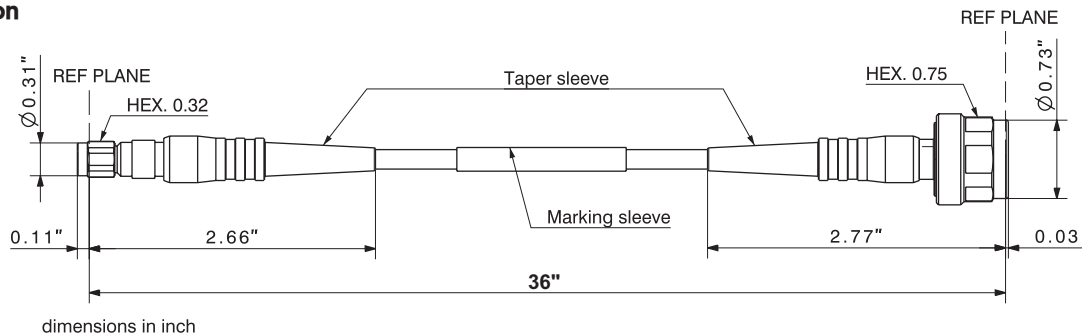

## Electrical table

		up to 2 GHz	2.01 to 4 GHz	4.01 to 6 GHz	6.01 to 12 GHz	12.01 to 18 GHz
Min. return loss	(dB)	30	28	25	21	19
Max. insertion loss at 25°C	(dB)	$< 0.48$	$< 0.68$	$< 0.84$	$< 1.21$	$< 1.51$
Max. cw power at 25°C, sea level	(W)	$> 391$	$> 277$	$> 225$	$> 160$	$> 131$
Max. insertion loss vs. shaking	(dB)	$< 0.03$	$< 0.03$	$< 0.03$	$< 0.03$	$< 0.03$
Max. insertion loss vs. bending	(dB)	$< 0.03$	$< 0.04$	$< 0.04$	$< 0.05$	$< 0.05$
Max. insertion loss vs. torsion	(dB)	$< 0.03$	$< 0.04$	$< 0.04$	$< 0.05$	$< 0.05$

## Care and handling instructions for HUBER + SUHNER microwave cables

HUBER + SUHNER microwave cable assemblies of all types offer a long service life providing they are treated with the appropriate care and attention. Microwave cable assemblies are high precision system components and require proper handling in order to ensure that measuring performance values are maintained.

To achieve the maximum measuring performance the following guidelines should be followed:

1. Assemblies should remain in their original packaging for delivery and storage. Storage temperature should be between -50 °C and +80 °C and the relative humidity should not exceed 85%.
2. Carefully unpack assemblies before measurement. Avoid kinking cables when straightening from a coil or reel.
3. Ensure that the surroundings are clean and free of dust, dirt and any other particles that could enter unsealed connector interfaces.
4. Use protective caps to prevent contamination whenever connectors are unmated.
5. Where interfaces are contaminated, particles can be removed with dry, oil-free compressed air. Please use eye-protection. Interfaces can be cleaned with dry cotton swabs. Do not use hard hand-tools or solvents. Do not blow into interfaces or use normal compressed-air.
6. Choose the measurement routing using the largest bend radii possible. Small bend radii may affect electrical performance. Exceeding the specified limits during the measurement process could cause a permanent degradation.
7. Avoid twisting microwave cable assemblies. Torsion of this type of assembly can alter the relative diameters of cable layers and affects the electrical characteristics. Exceeding the limit of 10° per metre during measuring process could cause a permanent degradation.
8. Examine interfaces for damage and/or contamination before mating.
9. Discharge connectors before mating or ensure that they are connected to a suitable ground.
10. When mating connectors with a screwed interface always hold the connector bodies and turn only the coupling nut. This avoids twisting the cable and ensures minimum wear on the connector pins.
11. Do not exceed the torque specified.

**The HUBER+SUHNER is certified according to ISO 9001 and ISO 14001.**

**WAIVER**

While the information contained in this folder has been carefully compiled to the best of our present knowledge, it is not intended as representation or warranty of any kind on our part regarding the suitability of the products concerned for any particular use or purpose and neither shall any statement contained herein be construed as a recommendation to infringe any industrial property rights or as a license to use any such rights. The suitability of each product for any particular purpose must be checked beforehand with our specialists.



HUBER+SUHNER AG  
Mobile Communications+Electronics  
9100 Herisau/Switzerland  
Tel. +41 (71) 353 41 11  
Fax +41 (71) 353 45 90  
www.hubersuhner.com

**Excellence in connectivity solutions**

## X-ON Electronics

Largest Supplier of Electrical and Electronic Components

*Click to view similar products for [huber & suhner](#) manufacturer:*

Other Similar products are found below :

[31 MMBX-SMA-50-1/111\\_NE](#) [74Z-0-23-17](#) [32 MMBX-50-0-6 / 111\\_NE](#) [TL8A-11SMA-11SMA-03000-51](#) [TL8A-11SMA-11SMA-01500-51](#)  
[23\\_SMA-50-0-1/111\\_NE](#) [TL-8A-11N-11SMA-01500-51](#) [7404.17.0003](#) [24\\_BNT-50-2-1/103\\_NE](#) [5906.17.0005](#) [53\\_SMA-50-0-2/111\\_NE](#)  
[Microbend R-13](#) [5910\\_SMA-50-005/19-\\_NE](#) [16\\_SMA-50-2-55/199\\_NE](#) [16\\_SMA-50-2-43/133\\_NE](#) [11\\_716-50-7-31/033\\_-Y](#) [Minibend L-13](#)  
[6550.17.AA](#) [Microbend R-4.5](#) [74\\_Z-0-0-53](#) [6603\\_SMA-50-2/199\\_NE](#) [85\\_SMC-50-0-1/133\\_NE](#) [MF53/1x8A\\_21MXP/11SK/305](#)  
[1324.17.0114](#) [75\\_Z-0-0-51](#) [31\\_PC24-SK-50-1/199\\_NE](#) [65\\_BNC-50-0-2/133\\_NE](#) [76\\_Z-0-10-14](#) [11\\_N-50-4-19/12-\\_NE](#) [80346275](#) [23\\_SHV-](#)  
[50-0-2/133\\_NE](#) [33\\_SMA-QMA-50-1/133\\_NE](#) [11\\_C-50-7-6/133\\_NE](#) [6806.19.A](#) [33\\_716-N-50-51/-33\\_NE](#) [5930\\_N-50-050/19-\\_NE](#) [16\\_BNC-](#)  
[50-7-6/133\\_NE](#) [Mini141 K-8](#) [33\\_BNC-N-50-1/133\\_NE](#) [6701.01.B](#) [33\\_BNC-QLA-01-1/1--\\_NE](#) [25\\_N-50-7-8/133\\_NE](#) [22\\_BNC-50-0-](#)  
[5/133\\_NE](#) [6500\\_N-50-1/199\\_NE](#) [3401.17.0033](#) [6601\\_SMA-50-1/199\\_NE](#) [74\\_Z-0-0-56](#) [3401.00.0022](#) [MF53/1x8A\\_21MXP/21SK\\_erg/305](#)  
[3402.17.K](#)