

LC013B – COB(Chip on Board) LED



Introduction

Features

- 13W COB LED : 17.0 x 17.0 x t 1.5 (mm)
- InGaN/GaN MQW LED with long-time reliability
- Lead (Pd) free product - RoHS compliant

Applications

- Spot / Downlighting
- LED Retrofit Bulbs
- Outdoor illumination
- Other applications

SAMSUNG ELECTRONICS

95, Samsung2-Ro, Giheung-Gu,
Yongin-City, Gyeonggi-Do 446-711, KOREA

Copyright © 2013 SAMSUNG ELECTRONICS Co.,Ltd. All rights reserved. The information in this document is subject to change without notice. SAMSUNG,  SAMSUNG is a registered trademark of SAMSUNG ELECTRONICS.

Contents

1. Absolute Maximum Rating	-----	3
2. Characteristics	-----	3
3. Binning Structure	-----	4
4. Chromaticity Coordinates	-----	6
5. Typical Characteristics Graph	-----	8
6. Outline Drawing & Dimension	-----	10
7. Reliability Test Items and Conditions	-----	11
8. Label Structure	-----	12
9. Lot Number	-----	13
10. Tray Dimension	-----	14
11. Aluminum Bag Dimension	-----	14
12. Box & Pad Dimension	-----	15
13. Packing Structure	-----	16
14. Precaution for use	-----	18
15. Revision History	-----	20

1. Absolute Maximum Rating

- 1) Operation Forward Current ($T_a = 25^\circ\text{C}$) 660mA
- 2) LED Junction Temperature (T_J) 150°C
- 3) Operating Temperature Range (T_{opr}) $-40^\circ\text{C} \sim 105^\circ\text{C}$
- 4) Storage Temperature Range (T_{stg}) $-40^\circ\text{C} \sim 120^\circ\text{C}$
- 5) Power Dissipation (P_D) 25W

2. Characteristics

- 1) Electro-Optical characteristics ($T_a : 25^\circ\text{C}$)

Item	Unit	Condition	Rank		Min	Typ	Max	
Luminous Flux ¹⁾	lm ²⁾	$I_F = 360 \text{ mA}$	2700K	1F	13	1300	-	1400
					14	1400	-	1500
					15	1500	-	1600
					16	1600	-	1700
			3000K	1F	13	1350	-	1450
					14	1450	-	1560
					15	1560	-	1670
					16	1670	-	1780
			4000K	1F	15	1430	-	1540
					16	1540	-	1660
					17	1660	-	1780
					18	1780	-	1900
			5000K	1F	15	1430	-	1560
					16	1560	-	1680
					17	1680	-	1800
					18	1800	-	1920
Forward Voltage	V ³⁾	$I_F = 360 \text{ mA}$	YH		32.5	35.5	38.5	
CRI ⁴⁾		$I_F = 360 \text{ mA}$	-		80	-	-	
Thermal Resistance ($R_{th,j-c}$)	$^\circ\text{C}/\text{W}$	-	-			1.6		
View Angle	$^\circ$	$I_F = 360 \text{ mA}$	-		-	115 $^\circ$	-	

Note :

- 1) Samsung LED tested in pulsed condition. $T_J=25^\circ\text{C}$, pulse width is 10ms at rated test current.
- 2) Samsung LED has $\pm 7\%$ tolerance of flux measurements.
- 3) Samsung LED has $\pm 5\%$ tolerance of forward voltage measurements.
- 4) Samsung LED has ± 1 tolerance of CRI measurements.

3. Binning Structure

(Condition : $I_F = 360 \text{ mA}$, $T_a : 25^\circ\text{C}$)

1) VF Binning

CCT	Product Code	VF Rank	VF (V)		
			Min	Typ	Max
2700K	SPHWW1HDNA25Y <u>H</u> W31F	YH	32.5	35.5	38.5
3000K	SPHWW1HDNA25Y <u>H</u> V31F	YH	32.5	35.5	38.5
4000K	SPHWW1HDNA25Y <u>H</u> T31F	YH	32.5	35.5	38.5
5000K	SPHCW1HDNA25Y <u>H</u> RT1F	YH	32.5	35.5	38.5

2) Color Binning

CCT	Product Code	Color Rank	Chromaticity Bins
2700K	SPHWW1HDNA25YH <u>W</u> 31F	W3	WA
3000K	SPHWW1HDNA25YH <u>V</u> 31F	V3	VA
4000K	SPHWW1HDNA25YH <u>T</u> 31F	T3	TA
5000K	SPHCW1HDNA25YH <u>RT</u> 1F	RT	RW, RX, RY, RZ

3) Luminous Flux Binning

CCT	Product Code	Flux Rank	Flux Bin	Range (lm)		
				Min	Typ	Max
2700K	SPHWW1HDNA25YHW31F	1F	13	1300	-	1400
			14	1400	-	1500
			15	1500	-	1600
			16	1600	-	1700
3000K	SPHWW1HDNA25YHV31F	1F	13	1350	-	1450
			14	1450	-	1560
			15	1560	-	1670
			16	1670	-	1780
4000K	SPHWW1HDNA25YHT31F	1F	15	1430	-	1540
			16	1540	-	1660
			17	1660	-	1780
			18	1780	-	1900
5000K	SPHCW1HDNA25YHRT1F	1F	15	1430	-	1560
			16	1560	-	1680
			17	1680	-	1800
			18	1800	-	1920

4. Chromaticity Coordinates

(Condition : $I_F = 360 \text{ mA}$, $T_a = 25^\circ\text{C}$)

1) 2700K

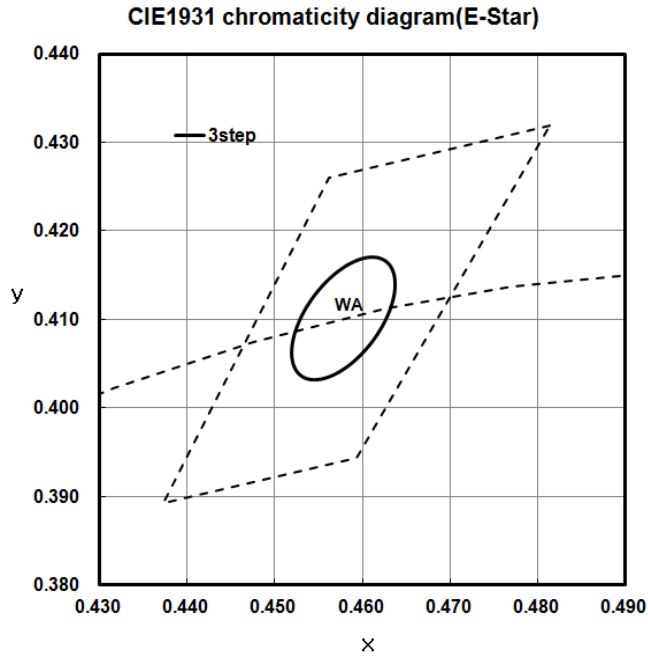

Macadam Ellipse				
3step (WA)				
x	y	θ	a	b
0.4578	0.4101	53.7	0.0081	0.0042

2) 3000K

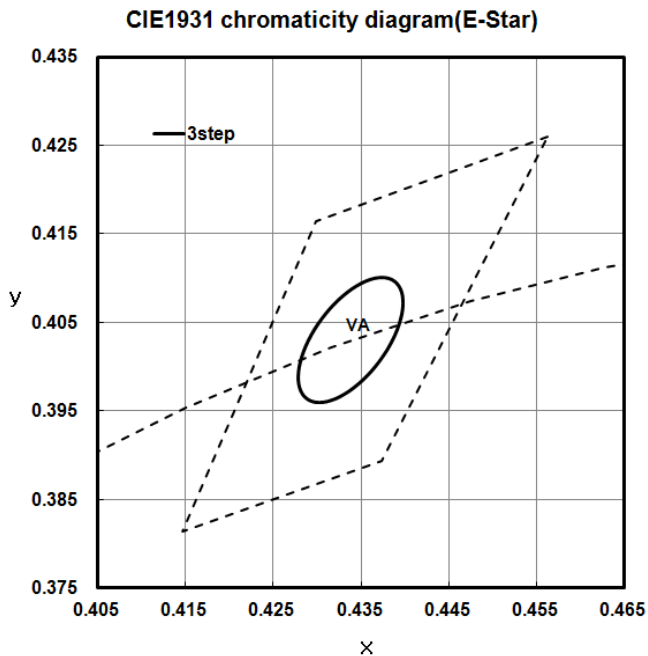

Macadam Ellipse				
3step (VA)				
x	y	θ	a	b
0.4338	0.4030	53.22	0.0083	0.0041

3) 4000K

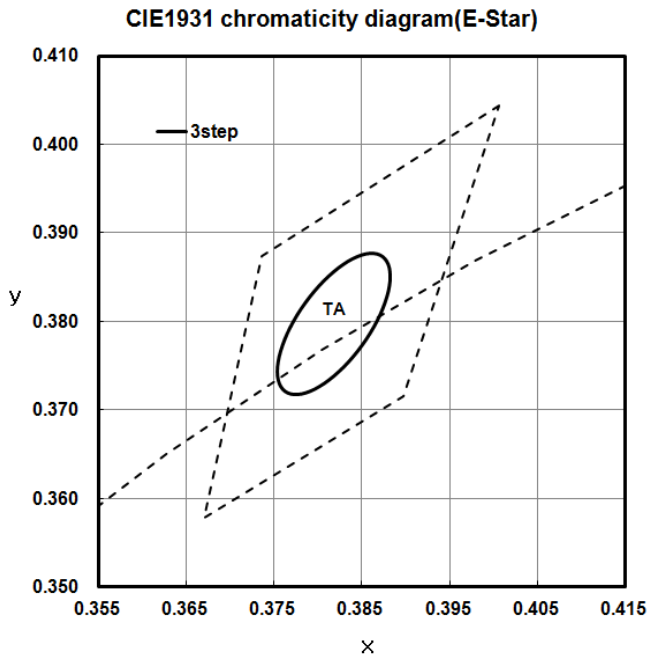

Macadam Ellipse				
3step (TA)				
x	y	θ	a	b
0.3818	0.3797	53.72	0.0094	0.0040

4) 5000K

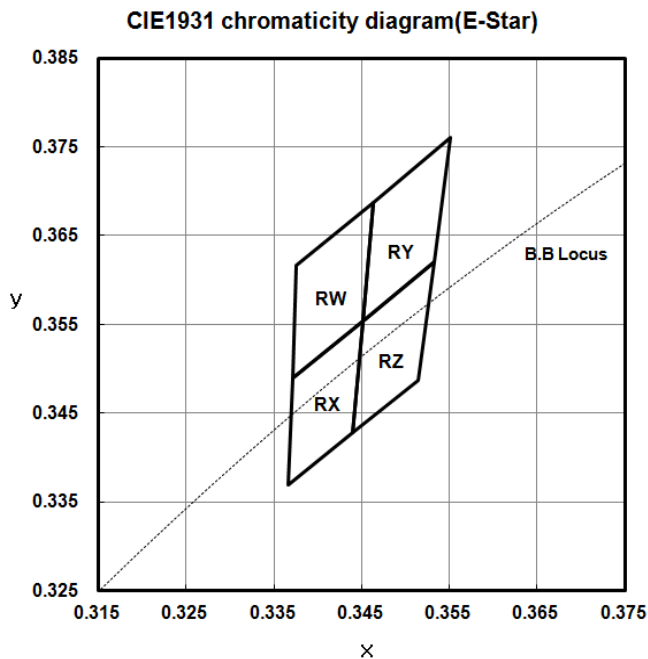

Table	CIE X	CIE Y
RW	0.3376	0.3616
	0.3463	0.3687
	0.3451	0.3554
	0.3371	0.3490
RX	0.3371	0.3490
	0.3451	0.3554
	0.3440	0.3428
	0.3366	0.3369
RY	0.3463	0.3687
	0.3551	0.3760
	0.3533	0.3620
	0.3451	0.3554
RZ	0.3451	0.3554
	0.3533	0.3620
	0.3515	0.3487
	0.3440	0.3428

Note :

- 1) The Chromaticity Coordinates refers to ANSI C78.377-2008
- 2) Samsung LED has ± 0.005 tolerance of chromaticity(x,y).

5. Typical Characteristics Graph

* These graphs show typical values. (Ta : 25°C)

Relative Luminous Flux vs. Forward Current

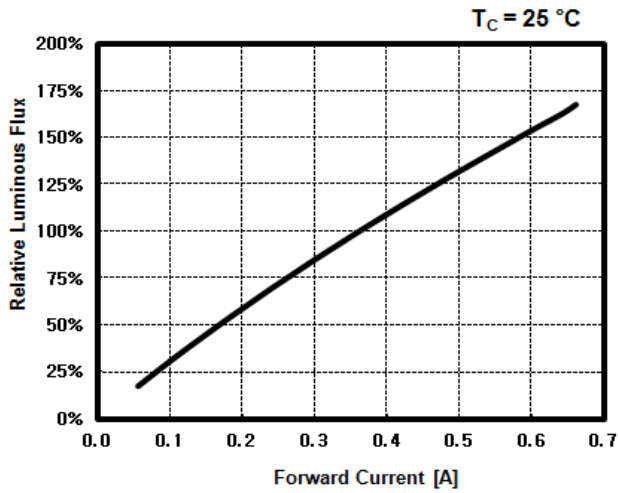

Forward Voltage vs. Forward Current

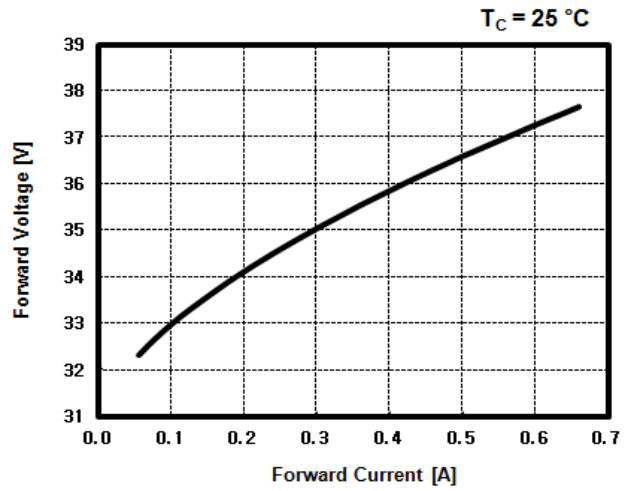

Chromaticity vs. Forward Current

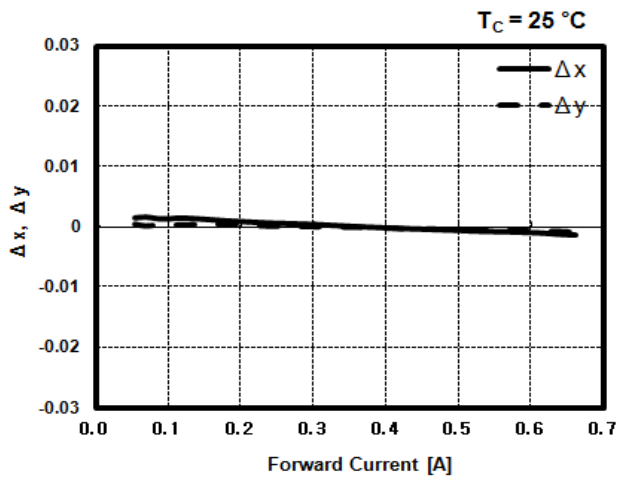

Chromaticity vs. Temperature

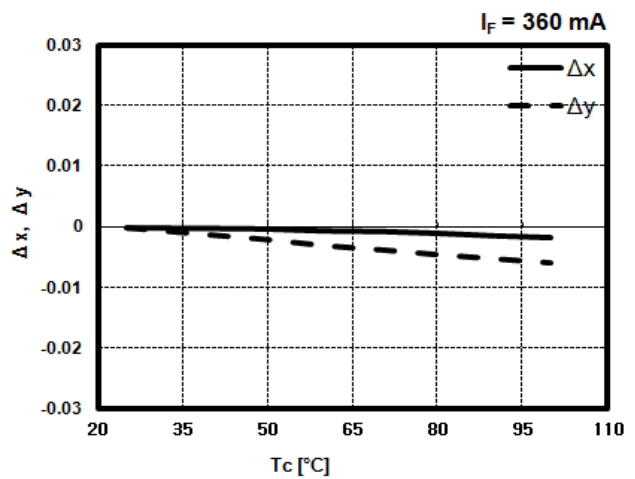

Forward Voltage vs. Temperature

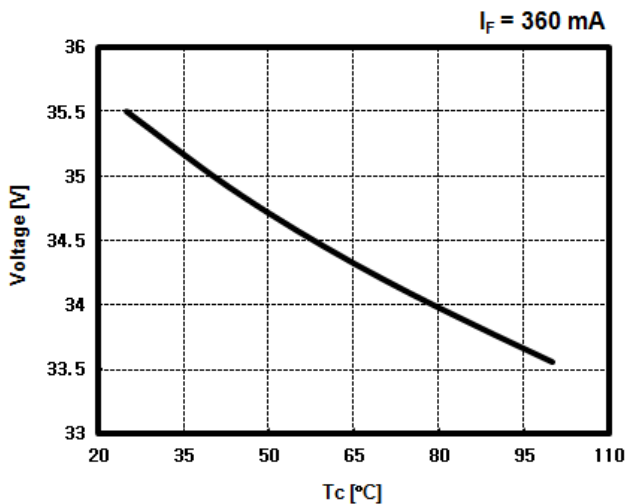

Relative Luminous Flux vs. Temperature

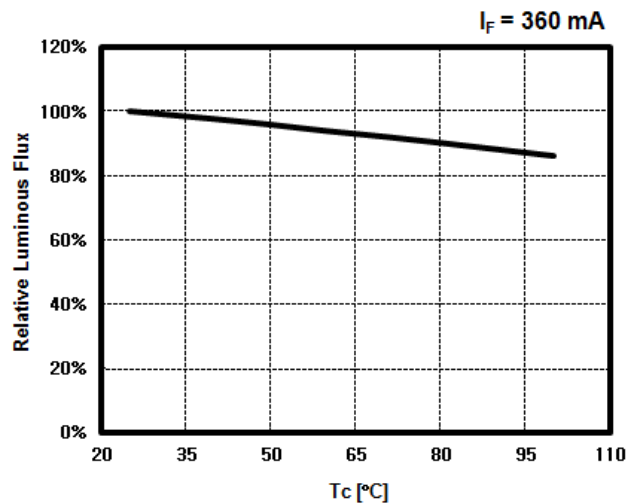

Relative Spectral Emission

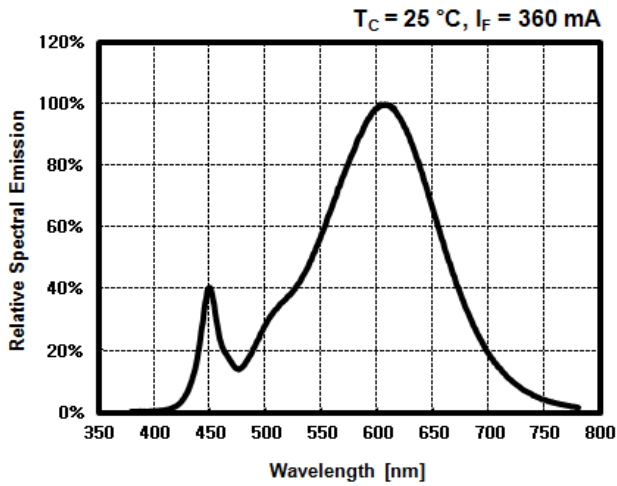

<2700K>

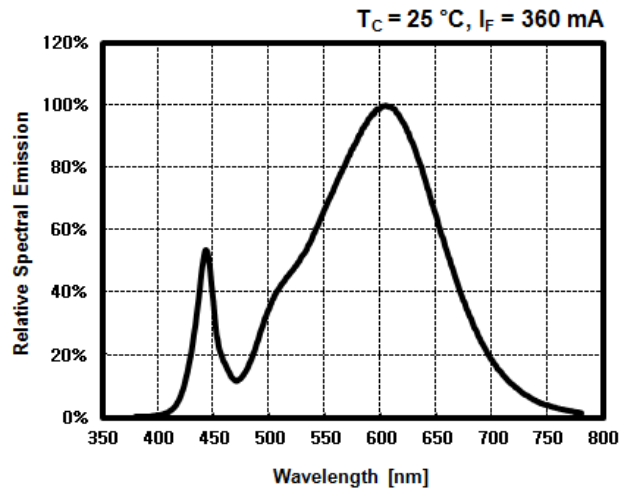

<3000K>

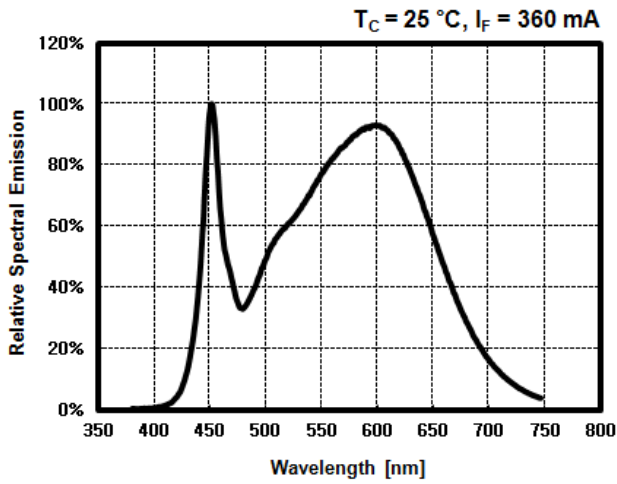

<4000K>

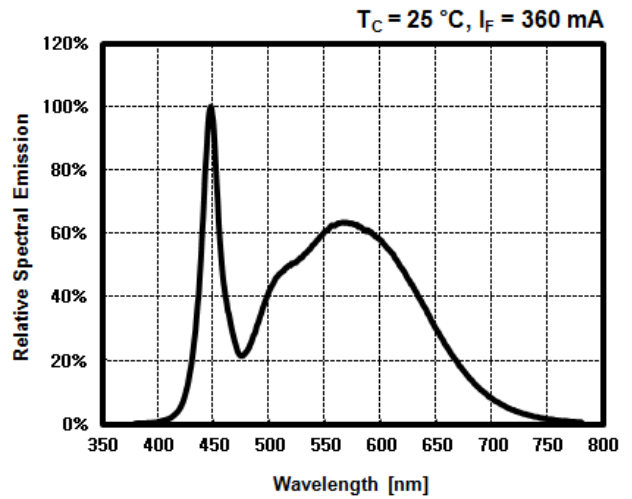

<5000K>

Radiation Pattern

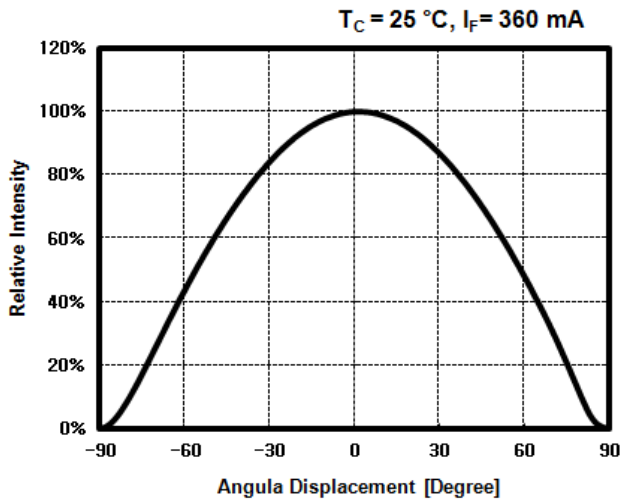

Derating Curve

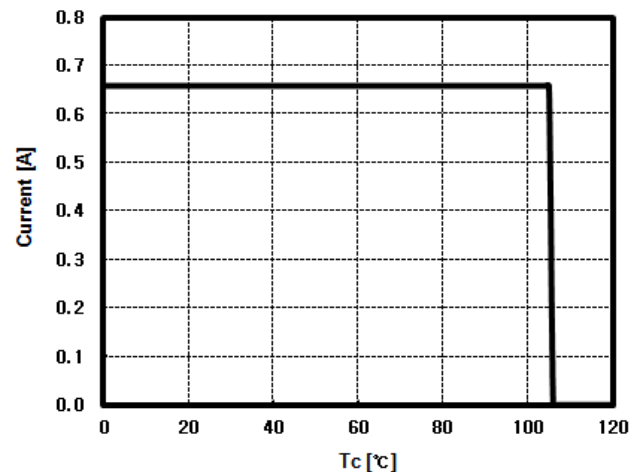

6. Outline Drawing & Dimension

unit : mm
Tolerance : ± 0.15

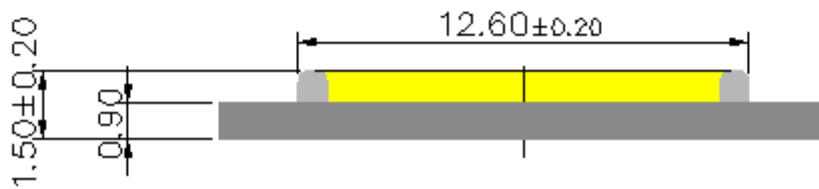
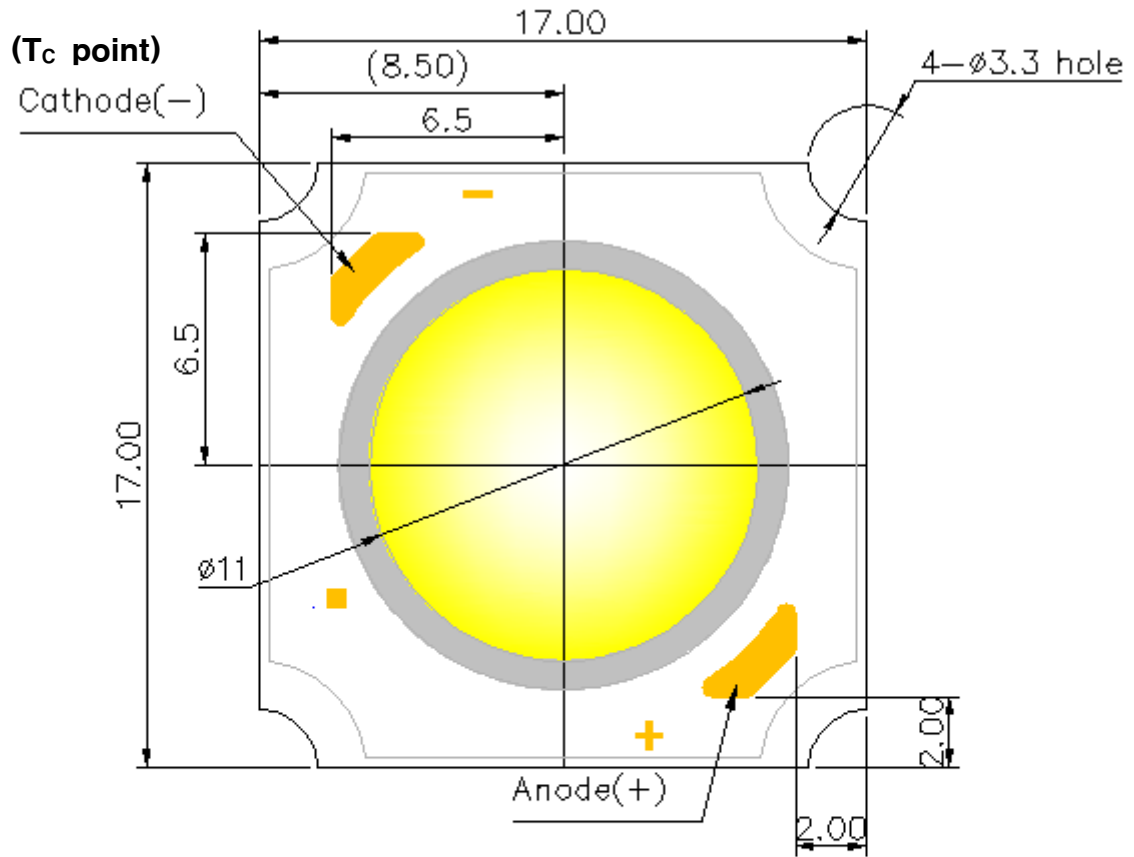

7. Reliability Test Items and Conditions

1) Test Items

Test Items	Test Conditions	Test Hours/Cycles
Room Temperature life test	25°C, $I_F = \text{Max}$	1,000 h
High Temperature humidity life test	85°C, 85% RH, DC Derating $I_F = \text{Max}$	1,000 h
High Temperature life test	105°C, DC Derating $I_F = \text{Max}$	1,000 h
Low Temperature life test	-40°C, DC 660 mA	1,000 h
High Temperature Storage	120°C	1,000 h
Low Temperature Storage	-40°C	1,000 h
Thermal Shock	-45°C/15min → 125°C/15min Temperature changes in 5min.	200 cycles
Temperature Cycle On/Off test	-40 / 85°C, each 20min, 100min transfer Power On/off each 5min, DC 360 mA	100 cycles
Temperature humidity Cycle Storage	-10°C ↔ 25°C, 95%RH ↔ 85°C, 95%RH [24h/1Cycle]	100 cycles
ESD(HBM)	R1 : 10 MΩ, R2 : 1.5 kΩ, C : 100 pF	5 times (± 5 kV)
ESD(MM)	R1 : 10 MΩ, R2 : 0 kΩ, C : 200 pF	5 times (± 0.5 kV)
Vibration	20~80Hz(Displacement:0.06inch, Max 20G) 80~2kHz (Max 20G) Min. Frequency ↔ Max. Frequency 4min transfer	4 times
Shock	1500G, 0.5ms, Every 6faces (3axis X 2faces)	5 times
Salt Spray	35°C, salt water 5% 8h spray → 16h leaving alone	2 cycles

2) Criteria for Failure

Item	Symbol	Test Condition [$T_a = 25^\circ\text{C}$]	Limit	
			Min.	Max.
Forward Voltage	V_F	660 mA	L.S.L. × 0.9	U.S.L. × 1.1
Luminous flux	I_m	660 mA	L.S.L. × 0.7	U.S.L. × 1.3

* U.S.L. : Upper Standard Level L.S.L. : Lower Standard Level



9. Lot Number

The Lot number is composed of the following characters

●◎◇◆□■△△△ / |▲▲▲ / xxx PCS

● : Production Site (S:SAMSUNG ELECTRONICS, G:Gosin China, A:Aprosystems)

◎ : L (LED)

◇ : Product State (A:Normality, B: Bulk, C:First Production, R:reproduction, S:Sample)

◆ : Year (U:2010, V:2011, W:2012, X:2013...)

□ : Month (1 ~ 9, A~C)

■ : Day (1 ~ 9, A, B ~ V)

△ : SAMSUNG LED Product number (1 ~ 999)

▲ : Tray Number (1 ~ 999)

10. Tray Dimension

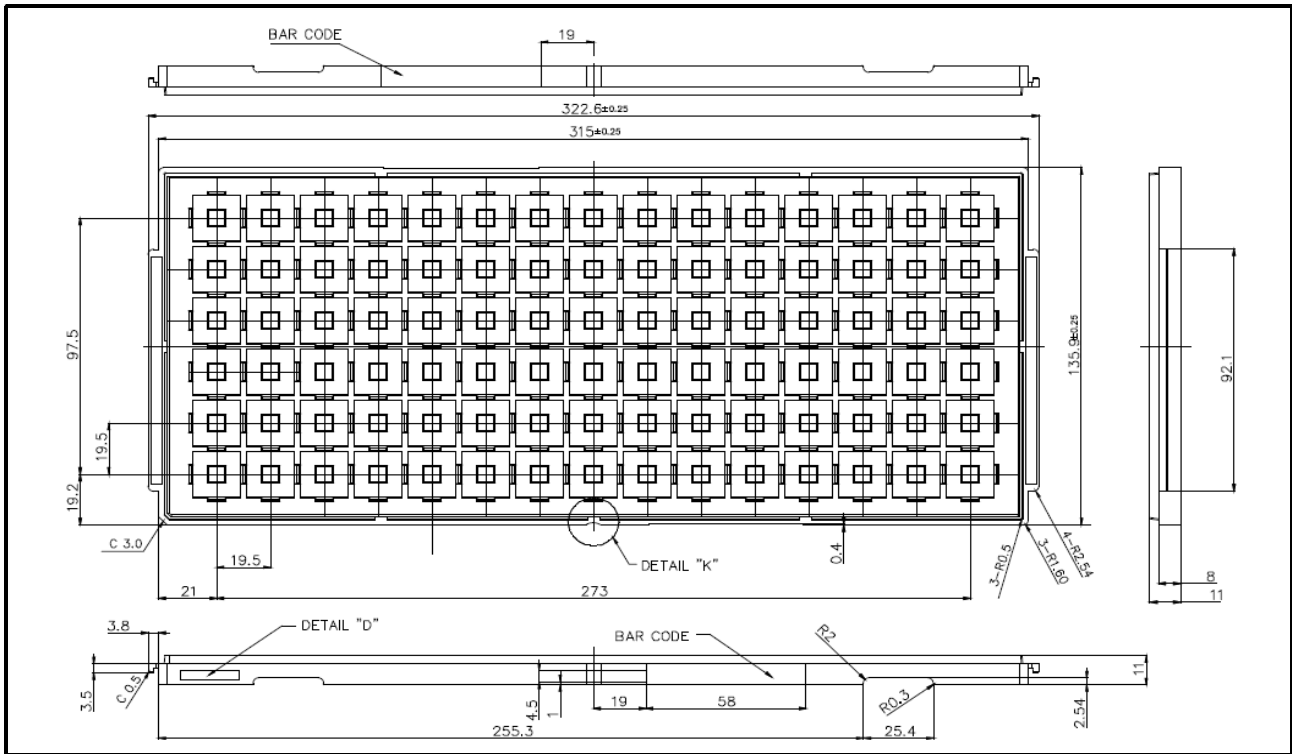

11. Aluminum Bag Dimension

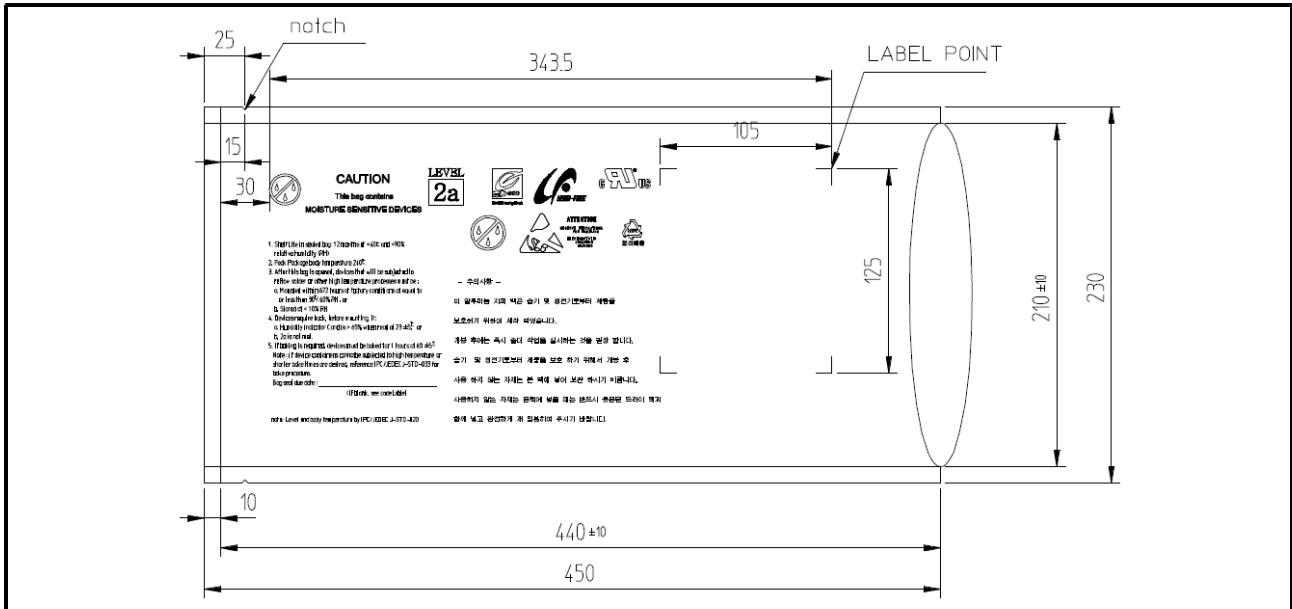

Silica gel & Humidity Indicator Card in Aluminum Bag



12. Box & Pad Dimension

1) Out BOX

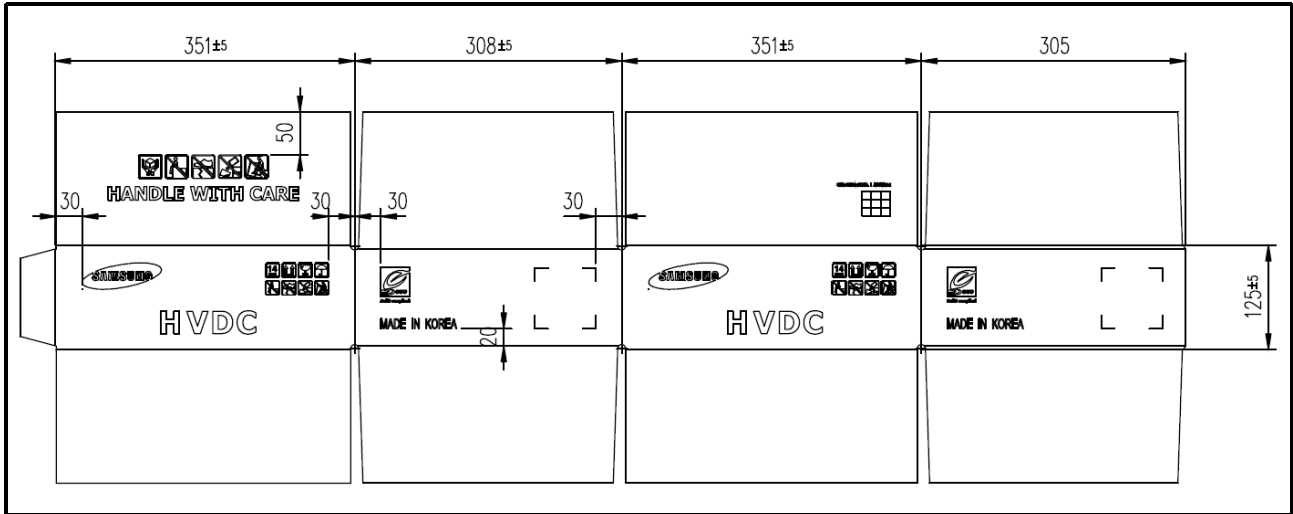

2) Inner BOX

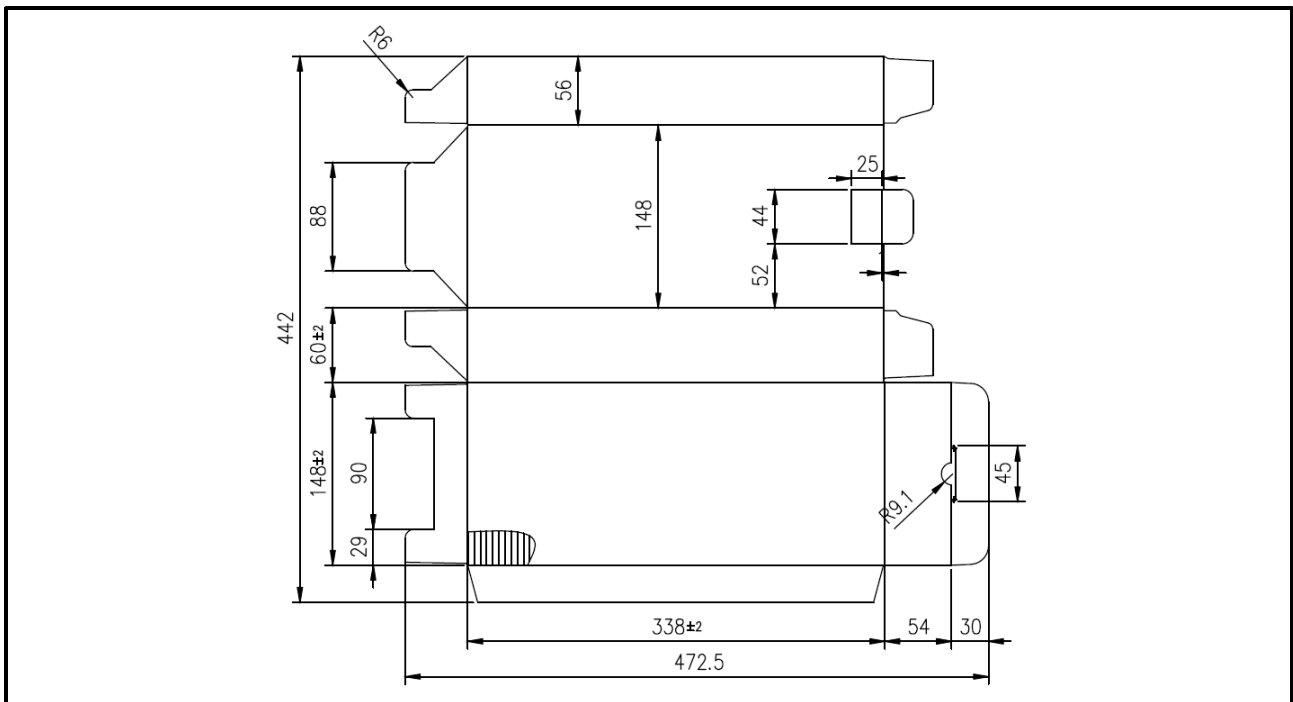

3) Pe-foam PAD

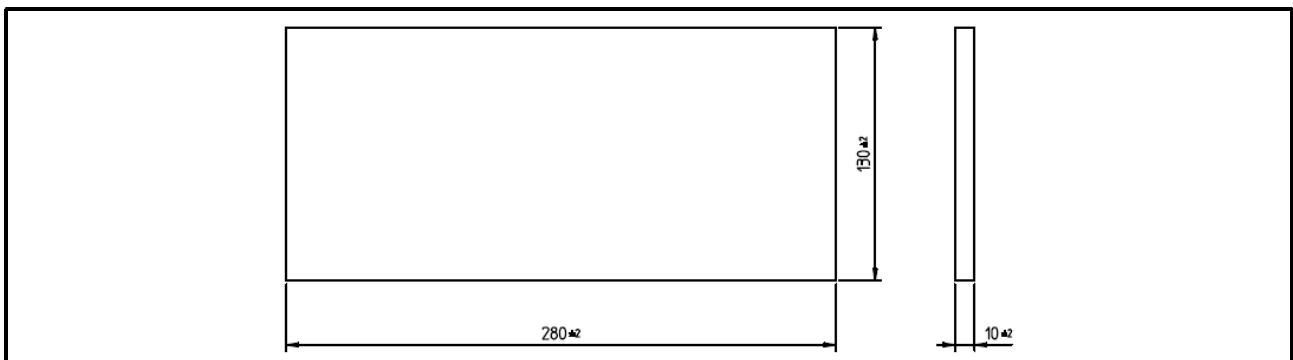

13. Packing Structure

1-1). Tray Packing (When 5 Trays)

Max Amount(pcs)		
Tray	Al Bag	Box
90	450	1800

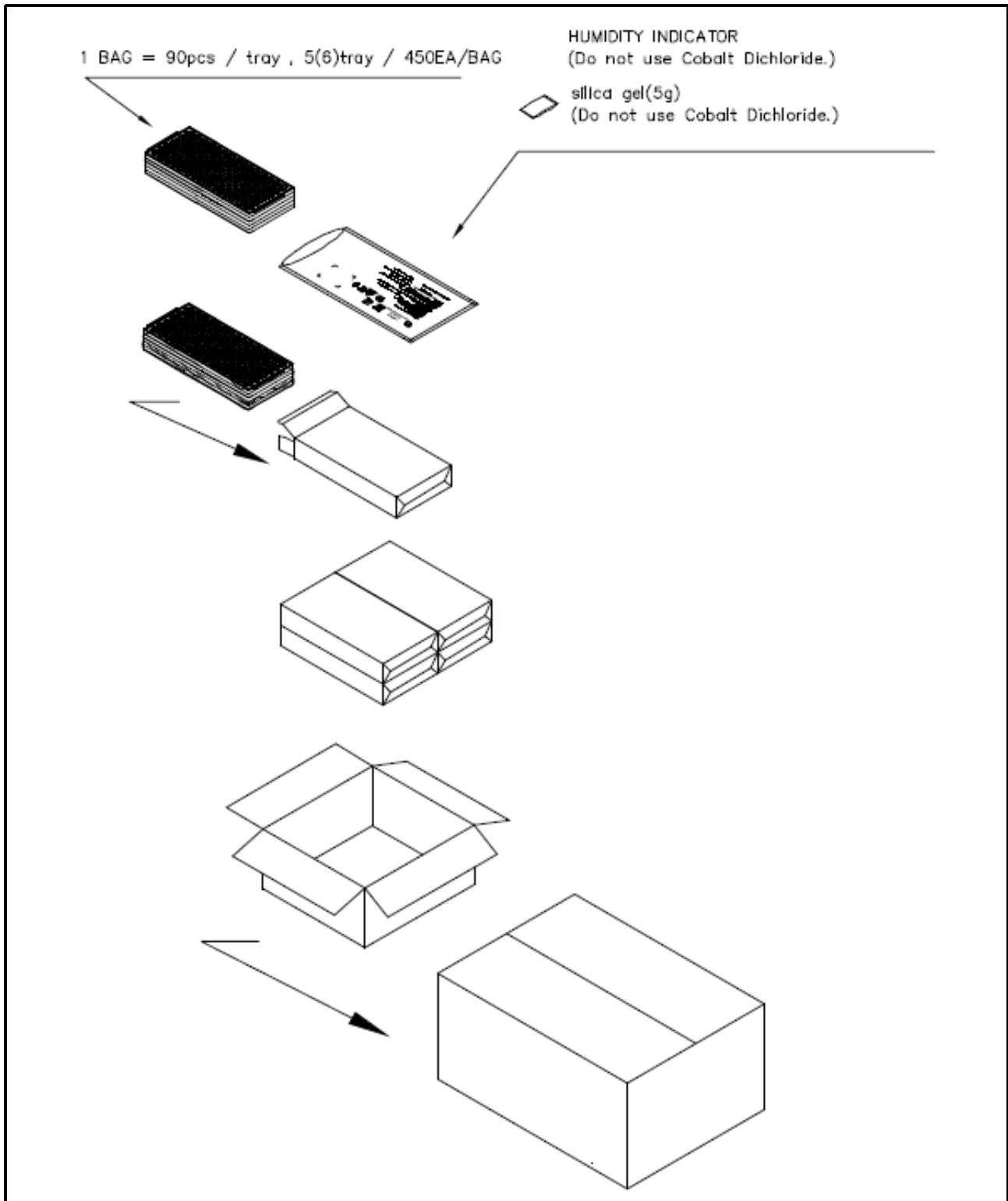

1-2). Tray Packing (When Less than 5 Trays)

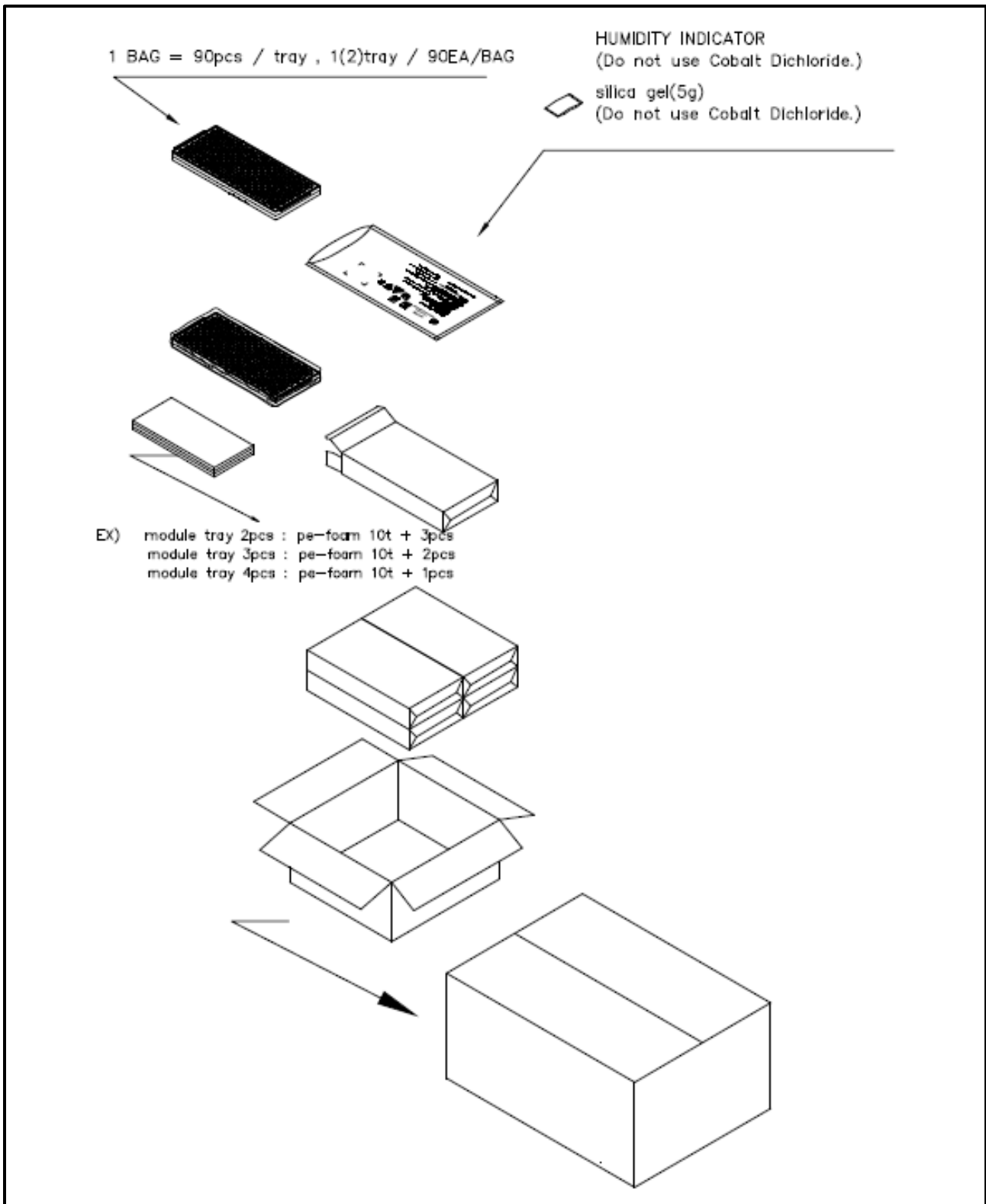

- EX) Module tray 2pcs : Pe-foam(10t) * 3pcs
- Module tray 3pcs : Pe-foam(10t) * 2pcs
- Module tray 4pcs : Pe-foam(10t) * 1pcs

14. Precaution for use

- 1) Shelf life in sealed bag : 12 months at $< 40^{\circ}\text{C}$ and $< 90\%$ relative humidity(RH)

- 2) Peak package body temperature : 240°C .

- 3) After this bag is opened, devices that will be subjected to reflow solder or other high temperature processes must be :
 - a. Mounted within 672 hours at factory conditions of equal to or less than 30°C / 60% RH, or
 - b. Stored at $< 10\%$ RH

- 4) Devices require bake, before mounting, if :
 - a. Humidity Indicator Card is $> 65\%$ when read at $23 \pm 5^{\circ}\text{C}$, or
 - b. 2a is not met.

- 5) If baking is required, devices must be baked for 1 hours at $60 \pm 5^{\circ}\text{C}$
Note : If device containers cannot be subjected to high temperature or shorter bake times are desired, reference IPC / JEDEC J-STD-033 for bake procedure.

- 6) The LEDs are sensitive to the static electricity and surge current.
It is recommended to use a wrist band or anti-electrostatic glove when handling the LEDs. If voltage exceeding the absolute maximum rating is applied to LEDs, it may cause damage or even destruction to LED devices.

Damaged LEDs may show some unusual characteristics such as increase in leakage current, lowered turn-on voltage, or abnormal lighting of LEDs at low current.

7) Please do not following behavior in resin area.

(Handling, Pressing, Touching, Rubbing, Contacting tweezers, Cleaning)

But it's ok in handling area.

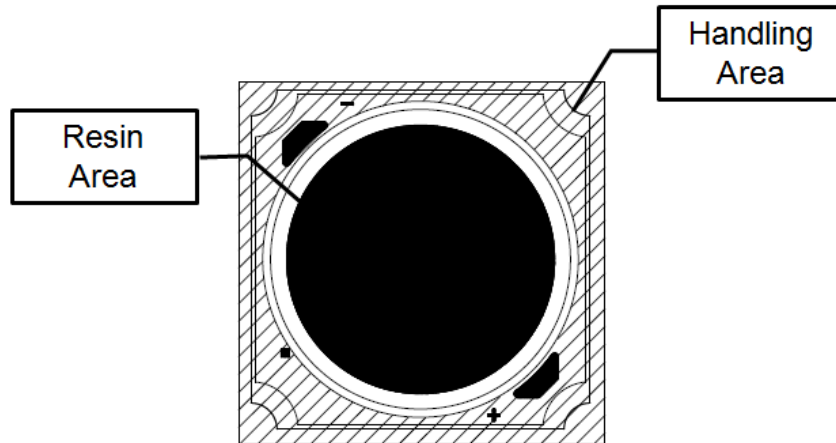

8) VOCs (volatile organic compounds) may be occurred by adhesives, flux, hardener or organic additives which is used in luminaires (fixture) and LED silicone bags are permeable to it. It may lead a discoloration when LED expose to heat or light.

This phenomenon can give a significant loss of light emitted(output) from the luminaires (fixtures).

In order to prevent these problems, we recommend you to know the physical properties for the materials used in luminaires, It requires to select carefully.

X-ON Electronics

Largest Supplier of Electrical and Electronic Components

Click to view similar products for [High Power LEDs - White category](#):

Click to view products by [Samsung manufacturer](#):

Other Similar products are found below :

[G42180-08](#) [B42180-08](#) [STW8Q2PA-R5-HA](#) [SZ5-M1-W0-00-V3/W2-AA](#) [LTPL-P00DWS57](#) [LZP-D0WW00-0000](#) [CLM-9-30-90-36-AC32-F4-3](#) [SZ5-M1-WW-C8-V1/V3-FA](#) [BXRC-27E2000-D-73](#) [BXRC-27G2000-D-73](#) [BXRC-30E1000-D-73](#) [BXRC-30G2000-D-73](#) [BXRC-40E1000-D-73](#) [BXRE-30G2000-B-73](#) [BXRE-30G2000-C-73](#) [BXRE-50C2001-C-74](#) [CXM-22-27-80-54-AC30-F4-3](#) [XHP50B-00-0000-0D0UH245G](#) [XHP50B-00-0000-0D0UH240G](#) [XHP50B-00-0000-0D0HJ245G](#) [MP-5050-8100-27-80](#) [MP-5050-6100-65-80](#) [MP-5050-6100-50-80](#) [MP-5050-6100-40-80](#) [MP-5050-6100-30-80](#) [CXM-22-30-80-54-AC30-F4-3](#) [LTW-2835SZK57](#) [BXEM-50C0000-0-000](#) [WW-WNA30TS-U1\(M1\)](#) [KW CSLPM2.CC-8L8M-4L8N](#) [KW CSLPM2.CC-8L8M-4O9Q](#) [KW DPLS32.SB-6H6J-E5P7-EG-Z264](#) [L1V1-507003V500000](#) [CXM-22-35-80-36-AC10-F3-3](#) [KW3 CGLNM1.TG-Z6QF6-EBVFFCBB46-DFGA](#) [JB5630AWT-H-H65EA0000-NZ000001](#) [XHP50B-00-0000-0D0UG430H](#) [CXM-22-35-90-54-AC40-F5-3](#) [CXM-22-35-80-54-AC40-F5-3](#) [OSM51206E1N-0.8T](#) [OSW43020C1C](#) [MP161611032290](#) [MP-1616-2103-50-90](#) [KW CULPM1.TG-Z6RF7-ebvFfcbB46-65G5](#) [KW DMLS33.SG-Z6M7-EBVFFCBB46-8E8G-700-S](#) [XPGDWT-B1-0000-00EEA](#) [XHP70B-00-0000-0D0BP450E](#) [KW DMLN33.SG-7J7K-EBVFFCBB46-8E8G-200-S](#) [ASMT-MW05-NMNS1](#)
[ASMT-MW06-NMNZ1](#)