



Specifications:

Rosin Activated (RA) Flux:

It is a high activity core flux designed for excellent instant wetting action, even on Nickel surfaces. Although it is a RA-based material, the residues are non-corrosive if not cleaned. Per J-STD-004. Classified as ROM1 flux.

Water Soluble Flux:

It is a high-activity water-soluble core flux for soldering difficult metals. It is designed for optimal cleanability, along with minimal smoke and odor. Its residues must be removed.

It is classified as ORH1 per J-STD-004.

Rosin Mildly Activated (RMA) Flux:

It is an RMA based core flux that provides wetting action comparable to typical RA flux. Although it is an RMA-based material, the residues are non-corrosive if not cleaned.

It is categorized as ROL1 per J-STD-004.

No-Clean Flux:

It is a halide-free, rosin based no-clean core flux that provides excellent wetting combined with optimal reliability and cosmetics. It is compliant to Bellcore GR-78 and is classified as ROL0 per J-STD-004.

Specification Table:

Part Number	Standard Wire Gauge (AWG)	Diameter		Alloy Content Tin/Lead	Weight	Flux %	Flux Type	Softening Point Celsius (Flux Extract)	Acid Number (mg-KOH/ G Sample)	SIR (Surface Insulation Resistance)
		Inches	mm							
SPC22126	20	0.032	0.81	60/40	1lbs.	3.3%	Rosin (RA)	80°C	150-160	$>1.0 \times 10^9$
SPC22127	18	0.04	1.02	60/40						
SPC22128	16	0.05	1.27	60/40						
SPC22129	14	0.062	1.57	60/40						
SPC22130	24	0.02	0.51	63/37						
SPC22131	22	0.025	0.64	63/37						
SPC22132	20	0.032	0.81	63/37						
SPC22133	18	0.04	1.02	63/37						
SPC22134	16	0.05	1.27	63/37						
SPC22135	14	0.062	1.57	63/37						
SPC22123	22	0.025	0.64	60/40	0.5 lbs.					
SPC22124	20	0.032	0.81	60/40	0.5 lbs.					

Solder Wire



Part Number	Standard Wire Gauge (AWG)	Diameter		Alloy Content Tin/Lead	Weight	Flux %	Flux Type	Softening Point Celsius (Flux Extract)	Acid Number (mg-KOH/ G Sample)	SIR (Surface Insulation Resistance)
		Inches	mm							
SPC22125	21	0.025	0.64	63/37	0.5 lbs.	3.3%	Rosin (RA)	80°C	150-160	$>1.0 \times 10^9$
SPC22136	20	0.032	0.81	60/40	1lbs.		Water Soluble	60°C	120-130	
SPC22137	20	0.032	0.81	63/37	1lbs.		Rosin (RMA)	92°C	150-160	
SPC22138	20	0.032	0.81	63/37	1lbs.	1.1%	No Clean (NC600)	75°C	190-210	
SPC22139	20	0.032	0.81	63/37	1lbs.					
SPC22140	24	0.02	0.51	63/37	1lbs.					

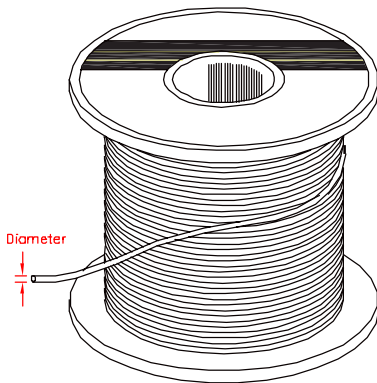

Note

The Water Soluble Solder has a flux within that must be cleaned; therefore, the Flux Extract Softening Point Test does not apply.

Acid Number test is based upon the IPC-TM-650 test method.

Flux Appearance : Amber Solid

Part Number Table

Description	Part Number
Solder Wire	SPC22126
	SPC22127
	SPC22128
	SPC22129
	SPC22130
	SPC22131
	SPC22132
	SPC22133
	SPC22134
	SPC22135
	SPC22123
	SPC22124
	SPC22125
	SPC22136
	SPC22137
	SPC22138
SPC22139	
SPC22140	

Important Notice : This data sheet and its contents (the "Information") belong to the members of the Premier Farnell group of companies (the "Group") or are licensed to it. No licence is granted for the use of it other than for information purposes in connection with the products to which it relates. No licence of any intellectual property rights is granted. The Information is subject to change without notice and replaces all data sheets previously supplied. The Information supplied is believed to be accurate but the Group assumes no responsibility for its accuracy or completeness, any error in or omission from it or for any use made of it. Users of this data sheet should check for themselves the Information and the suitability of the products for their purpose and not make any assumptions based on information included or omitted. Liability for loss or damage resulting from any reliance on the Information or use of it (including liability resulting from negligence or where the Group was aware of the possibility of such loss or damage arising) is excluded. This will not operate to limit or restrict the Group's liability for death or personal injury resulting from its negligence. DURATOOL is the registered trademark of the Group. © Premier Farnell plc 2012.



X-ON Electronics

Authorized Distributor

Click to view similar products for [Duratool](#) manufacturer.

Other Similar products are found below :

[D01894](#) [D01998](#) [D02153](#) [D03011](#) [D00080](#) [D02167](#) [D02286](#) [793902](#) [MC23781](#)

[DTRSR2032W](#) [DTRPGSB1519A](#) [DTRNSE1207M38](#) [DTRNSE1207M225](#)

[DTRNSE1207M220](#) [DTRHTSAM6252](#) [9750010](#) [NUTCAPTIVENO8PK100](#)

[M10N5STZ100](#) [793905](#) [793929](#) [9700010](#) [DTRMSPS301](#) [DTRRLCBSRE601](#) [49900300](#)

[17038N008GPB](#)