



a time and place...  
for everything

# Wi-Sys Communications Inc.

## WS1357 – 13 mm x 13 mm x 5.8 mm

### Ultra Compact Embedded GPS Antenna Series

#### Applications:

- ◆ GPS Enabled Mobile Phones, PDAs & Laptops
- ◆ Portable GPS Handhelds
- ◆ GPS enabled M2M
- ◆ Military and Law Enforcement Radios
- ◆ GPS Enabled Offender Monitoring Systems
- ◆ Asset Tracking Equipment
- ◆ Automotive & Marine Navigation Systems



The Ultra Compact WS1357 Embedded GPS antenna series is most ideal for GPS Enabled mobile phones, PDAs, laptops and portable GPS Handhelds. The WS1357 antenna series features a 13 mm x 13 mm x 4 mm ceramic patch element, ESD circuit protection, a low noise amplifier and a SAW filter, enabling the WS1357 series to provide great out-of-band signal rejection performance, consistent and clear signal while minimizing loss-of-lock in an extremely small form factor. With its very compact 16 mm x 16 mm x 5.8 mm dimensions, the WS1357 antenna series is perfectly suited for OEM applications.

#### WS1357 dimensions

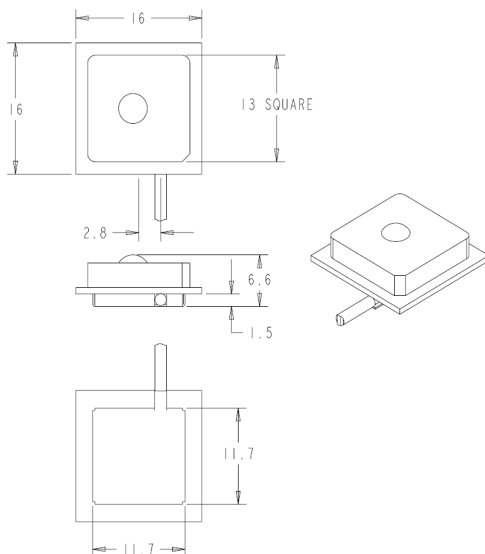

#### Features:

- ◆ 2.7 to 5 V operation
- ◆ Available with built-in 30mm ground plane (WS1367)
- ◆ Low power 18dB design also available (WS1356)
- ◆ Optional cable types and lengths available
- ◆ Other connector types available
- ◆ Ideal for embedded applications
- ◆ Low price



a time and place...  
for everything

## Wi-Sys Communications

### WS1357 Ultra Compact Embedded GPS Antenna

*Designed for easy integration into OEM handheld platforms, the WS1357 antenna integrates a highly robust ESD protection circuit, a low-noise amplifier to ensure a reliable and clear signal for the GPS receiver even in difficult conditions, as well as a SAW filter for even greater performance for hand held telematics applications where out-of-band signal rejection is required. The PCB protrudes 1.5mm*

#### Ordering Information:

**WS1357-A** - Designed to operate with just its 16mm LNA PCB (embedded ground plane) with no other ground plane. It is tuned on frequency with this small ground plane, which, precisely because it is small, is also the minimum gain configuration.

**WS1357-B** - Designed to be incorporated, with a soldered ground plane connection, into a user PCB that extends the ground plane to 30mm square.

**WS1357-C** - Designed to be incorporated into a large (80+mm) ground plane. This is the maximum gain configuration.

#### Other models available:

**WS1356** - Low gain (18dB) version.

**WS1367** - Includes a 30mm square ground plane.

## Technical Specifications

#### Environmental Specifications

- ◆ Operating temp: -40c to +85c (-45c to +80c storage)
- ◆ Humidity: 95% max (non condensing)

#### Mechanical

- ◆ **WS1357** – 16 mm x 16 mm x 5.8 mm
- ◆ Shock: Vertical axis 50G, other axes 30G
- ◆ Vibration: 3 axis, sweep = 15 min  
10–200 Hz log sweep: 3G

#### Antenna Response

- ◆ Frequency: 1575.42 MHz
- ◆ Gain: 0.5 dBic
- ◆ Polarization: Right Hand Circular
- ◆ Axial ratio: @ 90° 4 dB, @ 20° 6 dB

#### Electrical

- ◆ Voltage: 2.7 – 5 VDC
- ◆ Current: 9 mA @ 3.3V, 15 mA @ 5V,
- ◆ Connector: H.FL, other connector types available
- ◆ Cable: 1.5 mm dia. CO-6F.FH-SB cable
- ◆ Cable length: 15 cm (6”), other lengths available

#### LNA Specifications

- ◆ Frequency: 1572.5 – 1578 MHz
- ◆ Output Impedance: 50 Ohm
- ◆ VSWR: 1.5:1 max (at connector)
- ◆ Gain: @ 3.3VDC: 28 dB (typical)  
@ 5VDC: 30 dB (typical)
- ◆ Noise figure: 1.5 dB (typical)
- ◆ Out-of-band rejection: +/- 15 MHz: 5dB  
+/- 20 MHz: 10 dB  
+/- 30 MHz: 32 dB  
+/- 40 MHz: 40 dB

### Wi-Sys Communications Inc.

31B Richardson Side Road  
Ottawa, ON K2K 0A1 Canada  
Tel 613.254.7386 Fax 613.254.7388  
sales@wi-sys.com www.wi-sys.com



## **X-ON Electronics**

Largest Supplier of Electrical and Electronic Components

*Click to view similar products for [pctel](#) manufacturer:*

Other Similar products are found below :

[PCTMDL](#) [WS3911-HR-3M-SMA](#) [MLPV406](#) [GPS-TMG-MNT](#)