

Data Sheet

Rev. 1.10 / October 2012

ZSPM4013

High Efficiency 3A Synchronous Buck Converter



Power and Precision



ZSPM4013

High Efficiency 3A Synchronous Buck Converter

ZMDI
The Analog Mixed Signal Company



Brief Description

The ZSPM4013 is a DC/DC synchronous switching regulator with fully integrated power switches, internal compensation, and full fault protection. The 1MHz switching frequency enables using small filter components, resulting in reduced board space and reduced bill-of-materials costs.

The ZSPM4013 utilizes current mode feedback in normal regulation pulse-width modulation (PWM) mode. When the regulator is disabled (EN pin is low), the ZSPM4013 draws less than 10 μ A quiescent current.

The ZSPM4013 integrates a wide range of protection circuitry, including input supply under-voltage lockout, output voltage soft start, current limit, V_{OUT} over-voltage, and thermal shutdown. The ZSPM4013 includes supervisory reporting through the PG (Power Good) open drain output to interface other components in the system.

Features

- Output voltage options (depends on order code):
 - Fixed output voltages: 1.5V, 1.8V, 2.5V, 3.3V, or 5V with +/- 2% output tolerance
 - Adjustable output voltage range: 0.9V to 5V with +/- 1.5% reference
- Wide input voltage range: 6V to 18V
- 1MHz +/- 10% fixed switching frequency
- 3A continuous output current
- High efficiency – up to 95%
- Current mode PWM control with pulse-frequency modulation (PFM) mode for improved light load efficiency
- Voltage supervisor for V_{OUT} reported at the PG pin
- Input supply under voltage lockout
- Soft start for controlled startup with no overshoot
- Full protection for over-current, over-temperature, and V_{OUT} over-voltage
- Less than 10 μ A in Disabled Mode
- Low external component count

Benefits

- Increased battery life
- Minimal external component count (3 capacitors, 1 inductor)
- Inherent fault protection and reporting

Available Support

- Evaluation Kit
- Documentation

Physical Characteristics

- Junction operating temperature -40°C to 125°C
- Packaged in a 16pin QFN (3x3mm)

Related ZMDI Products

- ZSPM4011/ZSPM4012: 1A/2A synchronous buck converters, available with adjustable output from 0.9 to 5V or fixed output voltages at 1.5V, 1.8V, 2.5V, 3.3V, 5.0V (16-lead 3x3mm QFN)
- ZSPM1000: >5A single-phase, single-rail, true digital PWM controller (24-lead 4x4mm QFN)

ZSPM4013 Application Circuits

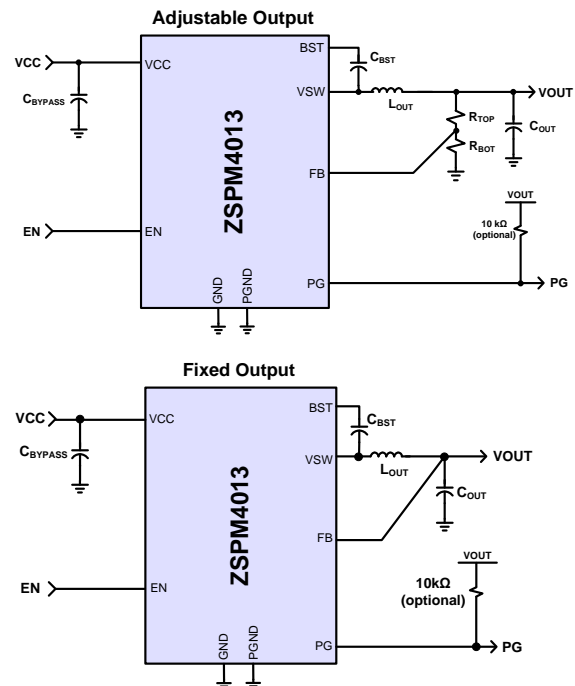

For more information, contact ZMDI via analog@zmdi.com.

ZSPM4013

High Efficiency 3A Synchronous Buck Converter



The Analog Mixed Signal Company



ZSPM4013 Block Diagram

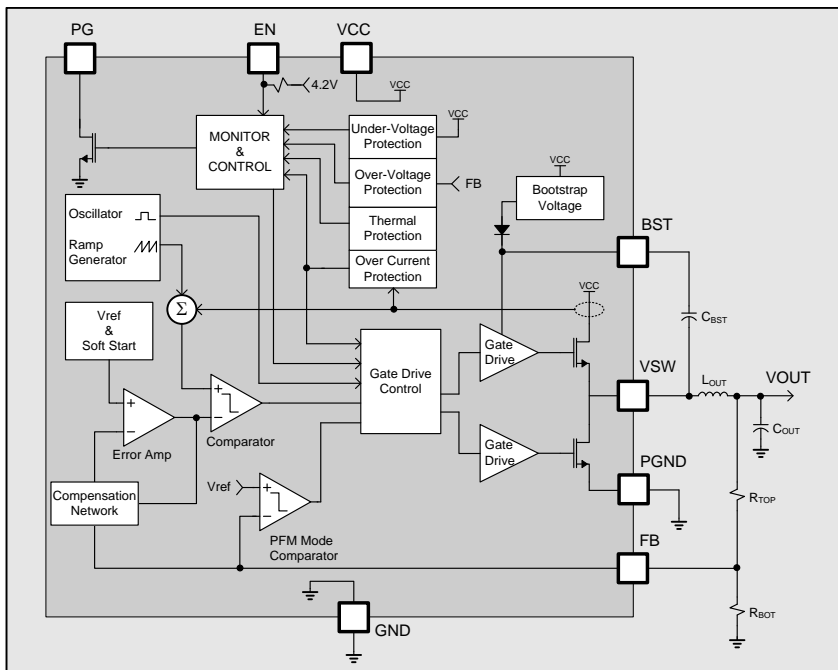

Typical Applications

- Wireless access points, cable modems
- Set-top boxes
- DVD, LCD, LED supplies
- Portable products, including GPS, smart phones, tablet PCs
- Printers

Ordering Information

Ordering Code	Description	Package
ZSPM4013AA1W00	ZSPM4013, 3A Synchronous Buck Converter: adjustable output, 0.9V to 5V, 16-pin 3x3mm QFN	7" reel with 1000 ICs
ZSPM4013AA1W15	ZSPM4013, 3A Synchronous Buck Converter: fixed output, 1.5V, 16-pin 3x3mm QFN	7" reel with 1000 ICs
ZSPM4013AA1W18	ZSPM4013, 3A Synchronous Buck Converter: fixed output, 1.8V, 16-pin 3x3mm QFN	7" reel with 1000 ICs
ZSPM4013AA1W25	ZSPM4013, 3A Synchronous Buck Converter: fixed output, 2.5V, 16-pin 3x3mm QFN	7" reel with 1000 ICs
ZSPM4013AA1W33	ZSPM4013, 3A Synchronous Buck Converter: fixed output, 3.3V, 16-pin 3x3mm QFN	7" reel with 1000 ICs
ZSPM4013AA1W50	ZSPM4013, 3A Synchronous Buck Converter: fixed output, 5.0V, 16-pin 3x3mm QFN	7" reel with 1000 ICs
ZSPM4013KIT	ZSPM4013KIT, Evaluation Kit for 3A Synchronous Buck Converter	Kit

Sales and Further Information

www.zmdi.com

analog@zmdi.com

Zentrum Mikroelektronik
Dresden AG
Grenzstrasse 28
01109 Dresden
Germany

ZMD America, Inc.
1525 McCarthy Blvd., #212
Milpitas, CA 95035-7453
USA

Zentrum Mikroelektronik
Dresden AG, Japan Office
2nd Floor, Shinbashi Tokyu Bldg.
4-21-3, Shinbashi, Minato-ku
Tokyo, 105-0004
Japan

ZMD FAR EAST, Ltd.
3F, No. 51, Sec. 2,
Keelung Road
11052 Taipei
Taiwan

Zentrum Mikroelektronik
Dresden AG, Korea Office
U-space 1 Building
11th Floor, Unit JA-1102
670 Sampyeong-dong
Bundang-gu, Seongnam-si
Gyeonggi-do, 463-400
Korea

Phone +49.351.8822.7.776
Fax +49.351.8822.8.7776

Phone 855-ASK-ZMDI
(855-275-9634)

Phone +81.3.6895.7410
Fax +81.3.6895.7301

Phone +886.2.2377.8189
Fax +886.2.2377.8199

Phone +82.31.950.7679
Fax +82.504.841.3026

DISCLAIMER: This information applies to a product under development. Its characteristics and specifications are subject to change without notice. Zentrum Mikroelektronik Dresden AG (ZMD AG) assumes no obligation regarding future manufacture unless otherwise agreed to in writing. The information furnished hereby is believed to be true and accurate. However, under no circumstances shall ZMD AG be liable to any customer, licensee, or any other third party for any special, indirect, incidental, or consequential damages of any kind or nature whatsoever arising out of or in any way related to the furnishing, performance, or use of this technical data. ZMD AG hereby expressly disclaims any liability of ZMD AG to any customer, licensee or any other third party, and any such customer, licensee and any other third party hereby waives any liability of ZMD AG for any damages in connection with or arising out of the furnishing, performance or use of this technical data, whether based on contract, warranty, tort (including negligence), strict liability, or otherwise.

ZSPM4013

High Efficiency 3A Synchronous Buck Converter



Contents

1	ZSPM4013 Characteristics.....	6
1.1.	Absolute Maximum Ratings.....	6
1.2.	Thermal Characteristics.....	6
1.3.	Recommended Operating Conditions	7
1.4.	Electrical Characteristics	7
1.5.	Regulator Characteristics	8
2	Typical Performance Characteristics	10
3	Description of Circuit	13
3.1.	Internal Protection Details	14
3.1.1.	Internal Current Limit	14
3.1.2.	Thermal Shutdown.....	14
3.1.3.	Reference Soft-Start	14
3.1.4.	Output Over-Voltage	14
3.1.5.	VCC Under-Voltage Lockout.....	14
4	Application Circuits.....	15
4.1.	Selection of External Components	15
4.2.	Typical Application Circuits.....	15
5	Pin Configuration and Package.....	16
5.1.	Marking Diagram & Pin-out	17
5.2.	Pin Description for 16 LEAD 3x3mm QFN	18
5.3.	Detailed Pin Description	19
5.3.1.	Unregulated Input, VCC (Pins # 2, 3)	19
5.3.2.	Bootstrap Control, BST (Pin #10)	19
5.3.3.	Sense Feedback, FB (Pin #5).....	19
5.3.4.	Switching Output, VSW (Pins #12, 13)	19
5.3.5.	Ground, GND (Pin #4)	19
5.3.6.	Power Ground, PGND (Pins #14, 15).....	19
5.3.7.	Enable, High-Voltage, EN (Pin #9)	19
5.3.8.	Power Good Output, PG (Pin #8)	19
6	Ordering Information	20
7	Related Documents.....	20
8	Glossary	20
9	Document Revision History	21

ZSPM4013

High Efficiency 3A Synchronous Buck Converter

ZMDI[®]

The Analog Mixed Signal Company



List of Figures

Figure 2.1	Startup Response	10
Figure 2.2	100mA to 1A Load Step ($V_{CC}=12V$, $V_{OUT}=1.8V$).....	10
Figure 2.3	100mA to 2A Load ($V_{CC}=12V$, $V_{OUT}=1.8V$).....	10
Figure 2.4	100mA to 1A Load Step ($V_{CC}=12V$, $V_{OUT}=3.3V$).....	10
Figure 2.5	100mA to 2A Load Step ($V_{CC}=12V$, $V_{OUT}=3.3V$).....	10
Figure 2.6	Line Transient Response ($V_{CC}=12V$, $V_{OUT}=3.3V$).....	10
Figure 2.7	Load Regulation.....	11
Figure 2.8	Line Regulation ($I_{OUT}=1A$).....	11
Figure 2.9	Efficiency vs. Output Current ($V_{OUT}=1.8V$).....	11
Figure 2.10	Efficiency vs. Output Current ($V_{OUT}=3.3V$).....	11
Figure 2.11	Efficiency vs. Output Current ($V_{OUT}=5V$).....	11
Figure 2.12	Efficiency vs. Input Voltage ($V_{OUT}=3.3V$).....	11
Figure 2.13	Standby Current vs. Input Voltage.....	12
Figure 2.14	Standby Current vs. Temperature	12
Figure 2.15	Output Voltage vs. Temperature.....	12
Figure 2.16	Oscillator Frequency vs. Temperature ($I_{OUT}=300mA$)	12
Figure 2.17	Quiescent Current vs. Temperature (No load)	12
Figure 2.18	Input Current vs. Temperature (No load, No switching)	12
Figure 3.1	ZSPM4013 Block Diagram	13
Figure 3.2	Monitor and Control Logic Functionality	14
Figure 4.1	Typical Application for Adjustable Output Voltage.....	15
Figure 4.2	Typical Application for Fixed Output Voltage.....	15
Figure 5.1	ZSPM4013 Package Drawing.....	16
Figure 5.2	16 Lead 3x3mm QFN (top view).....	17

List of Tables

Table 1.1	Absolute Maximum Ratings	6
Table 1.2	Thermal Characteristics	6
Table 1.3	Recommended Operating Conditions	7
Table 1.4	Electrical Characteristics	7
Table 5.1	Pin Description, 16 lead, 3x3mm QFN	18

ZSPM4013

High Efficiency 3A Synchronous Buck Converter



1 ZSPM4013 Characteristics

Important: Stresses beyond those listed under “Absolute Maximum Ratings” (section 1.1) may cause permanent damage to the device. These are stress ratings only. Functional operation of the device at these or any other conditions beyond those indicated under “Recommended Operating Conditions” (section 1.3) is not implied. Exposure to absolute–maximum–rated conditions for extended periods may affect device reliability.

1.1. Absolute Maximum Ratings

Over operating free–air temperature range unless otherwise noted.

Table 1.1 Absolute Maximum Ratings

Parameter	Value ¹⁾	UNIT
Voltage on VCC pin	-0.3 to 20	V
Voltage on BST pin	-0.3 to (VCC+6)	V
Voltage on VSW pin	-1 to 20	V
Voltage on EN, PG, FB pins	-0.3 to 6	V
Electrostatic Discharge – Human Body Model ²⁾	+/-2k	V
Electrostatic Discharge – Charge Device Model ²⁾	+/-500	V
Lead Temperature (soldering, 10 seconds)	260	°C

1) All voltage values are with respect to network ground terminal.
2) ESD testing is performed according to the respective JESD22 JEDEC standard.

1.2. Thermal Characteristics

Table 1.2 Thermal Characteristics

Parameter	Symbol	Value	Unit
Thermal Resistance Junction to Air ¹⁾	θ_{JA}	38	°C/W
Storage Temperature Range	T_{STG}	-65 to 150	°C
Maximum Junction Temperature	$T_{J\ MAX}$	150	°C
Operating Junction Temperature Range	T_J	-40 to 125	°C

1) Assumes 1 in² area of 2 oz. copper and 25°C ambient temperature.

ZSPM4013

High Efficiency 3A Synchronous Buck Converter



1.3. Recommended Operating Conditions

Table 1.3 Recommended Operating Conditions

Parameter	Symbol	Min	Typ	Max	Unit
Input Operating Voltage	VCC	6	12	18	V
Bootstrap Capacitor	C _{BST}	17.6	22	26.4	nF
Output Filter Inductor Typical Value ¹⁾	L _{OUT}	3.76	4.7	5.64	μH
Output Filter Capacitor Typical Value ²⁾	C _{OUT}	33	44 (2 x 22)		μF
Output Filter Capacitor ESR	C _{OUT-ESR}	2	35	100	mΩ
Input Supply Bypass Capacitor Typical Value ³⁾	C _{BYPASS}	8	10		μF

1) For best performance, an inductor with a saturation current rating higher than the maximum V_{OUT} load requirement plus the inductor current ripple.

2) For best performance, a low ESR ceramic capacitor should be used.

3) For best performance, a low ESR ceramic capacitor should be used. If C_{BYPASS} is not a low ESR ceramic capacitor, a 0.1μF ceramic capacitor should be added in parallel to C_{BYPASS}.

1.4. Electrical Characteristics

Electrical Characteristics, T_J = -40°C to 125°C, VCC = 12V (unless otherwise noted)

Table 1.4 Electrical Characteristics

Parameter	Symbol	Condition	Min	Typ	Max	Unit
VCC Supply Voltage						
Input Supply Voltage	VCC		6		18	V
Quiescent Current: Normal Mode	I _{CC-NORM}	VCC = 12V, I _{LOAD} = 0A, EN ≥ 2.2V		5.2		mA
Quiescent Current: Normal Mode, Non-switching	I _{CC-NOSWITCH}	VCC=12V, I _{LOAD} =0A, EN ≥ 2.2V Non-switching		2.3		mA
Quiescent Current: Disabled Mode	I _{CC-DISABLE}	VCC = 12V, EN = 0V		5	10	μA
VCC Under Voltage Lockout						
Input Supply Under Voltage Threshold	VCC-UV	VCC Increasing	5.5	5.75	6.0	V
Input Supply Under Voltage Threshold Hysteresis	VCC- UV_HYST			650		mV
Oscillator						
Oscillator Frequency	f _{OSC}		0.9	1	1.1	MHz

ZSPM4013

High Efficiency 3A Synchronous Buck Converter

ZMDI[®]

The Analog Mixed Signal Company



Parameter	Symbol	Condition	Min	Typ	Max	Unit
PG Open Drain Output						
PG Release Timer	T_{PG}			10		ms
High-Level Output Leakage	I_{OH-PG}	$V_{PG} = 5V$		0.5		μA
Low-Level Output Voltage	V_{OL-PG}	$I_{PG} = -0.3mA$			0.01	V
EN Input Voltage Thresholds						
High Level Input Voltage	V_{IH-EN}		2.2			V
Low Level Input Voltage	V_{IL-EN}				0.8	V
Input Hysteresis	$V_{HYST-EN}$			480		mV
Input Leakage	I_{IN-EN}	$V_{EN}=5V$		3.5		μA
		$V_{EN}=0V$		-1.5		μA
Thermal Shutdown						
Thermal Shutdown Junction Temperature	TSD	Note: Guaranteed by design	150	170		$^{\circ}C$
TSD Hysteresis	TSD_{HYST}			10		$^{\circ}C$

1.5. Regulator Characteristics

Electrical Characteristics, $T_J = -40^{\circ}C$ to $125^{\circ}C$, $V_{CC} = 12V$ (unless otherwise noted)

Parameter	Symbol	Condition	Min	Typ	Max	Unit
Switch Mode Regulator: $L_{OUT}=4.7\mu H$ and $C_{OUT}=2 \times 22\mu F$						
Output Voltage Tolerance in PWM Mode	$V_{OUT-PWM}$	$I_{LOAD} = 1A$	$V_{OUT} - 2\%$	V_{OUT}	$V_{OUT} + 2\%$	V
Output Voltage Tolerance in PFM Mode	$V_{OUT-PFM}$	$I_{LOAD} = 0A$	$V_{OUT} - 1\%$	$V_{OUT} + 1\%$	$V_{OUT} + 3.5\%$	V
High Side Switch On Resistance	R_{DSON}	$I_{VSW} = -1A$ (See table note 1)		180		$m\Omega$
Low Side Switch On Resistance		$I_{VSW} = 1A$ (See table note 1)		120		$m\Omega$
Output Current	I_{OUT}				3	A
Over Current Detect	I_{OCD}	HS switch current	3.4	3.8	4.4	A
Feedback Reference (Adjustable Mode)	FB_{TH}		0.886	0.9	0.914	V
Feedback Reference Tolerance	FB_{TH-TOL}		-1.5		1.5	%

ZSPM4013

High Efficiency 3A Synchronous Buck Converter

ZMDI[®]

The Analog Mixed Signal Company



Parameter	Symbol	Condition	Min	Typ	Max	Unit
Soft Start Ramp Time	T_{SS}			4		ms
PFM Mode FB Comparator Threshold	FB_{TH-PFM}			$V_{OUT} + 1\%$		V
V_{OUT} Under Voltage Threshold	V_{OUT-UV}		91% V_{OUT}	93% V_{OUT}	95% V_{OUT}	
V_{OUT} Under Voltage Hysteresis	$V_{OUT-UV-HYST}$			1.5% V_{OUT}		
V_{OUT} Over Voltage Threshold	V_{OUT-OV}			103% V_{OUT}		
V_{OUT} Over Voltage Hysteresis	$V_{OUT-OV-HYST}$			1% V_{OUT}		
Max Duty Cycle	$DUTY_{MAX}$	(See table note 2)	95%	97%	99%	

1) $R_{DS(on)}$ is characterized at 1A and tested at lower current in production.
2) Regulator VSW pin is forced off for 240ns every 8 cycles to ensure the BST cap is replenished.

ZSPM4013

High Efficiency 3A Synchronous Buck Converter



The Analog Mixed Signal Company



2 Typical Performance Characteristics

Figure 2.1 Startup Response

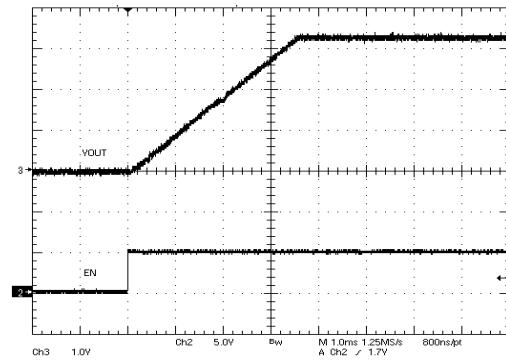

Figure 2.2 100mA to 1A Load Step ($V_{CC}=12V$, $V_{out}=1.8V$)

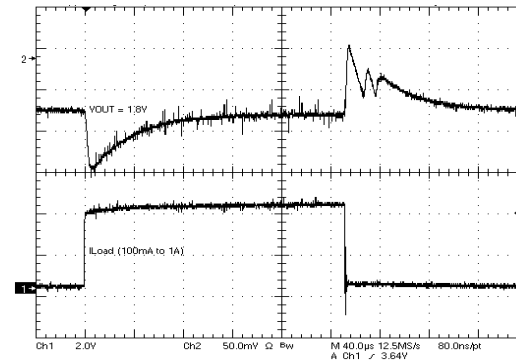

Figure 2.3 100mA to 2A Load ($V_{CC}=12V$, $V_{out}=1.8V$)

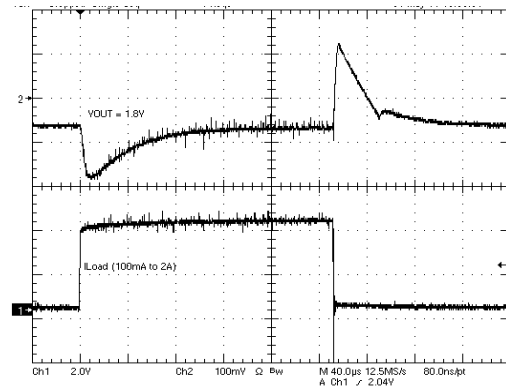

Figure 2.4 100mA to 1A Load Step ($V_{CC}=12V$, $V_{out}=3.3V$)

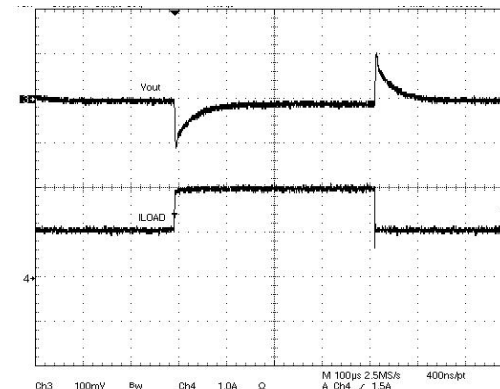

Figure 2.5 100mA to 2A Load Step ($V_{CC}=12V$, $V_{out}=3.3V$)

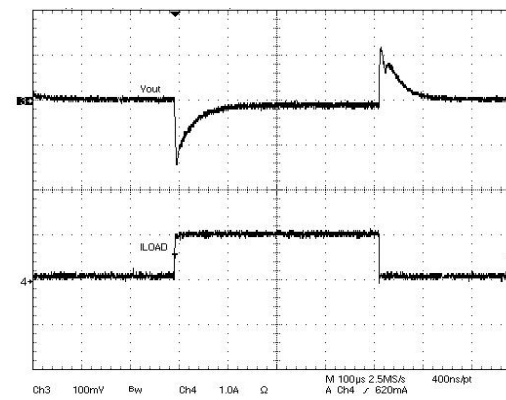
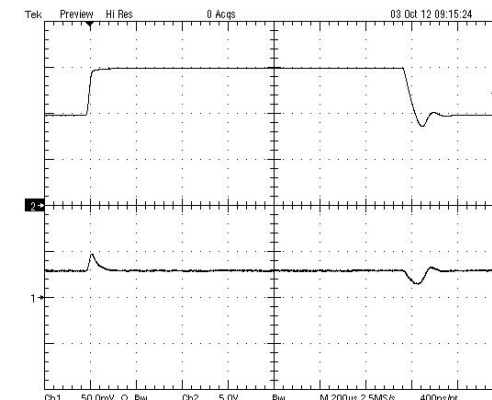

Figure 2.6 Line Transient Response ($V_{CC}=12V$, $V_{out}=3.3V$)



ZSPM4013

High Efficiency 3A Synchronous Buck Converter

ZMDI®

The Analog Mixed Signal Company



Figure 2.7 Load Regulation

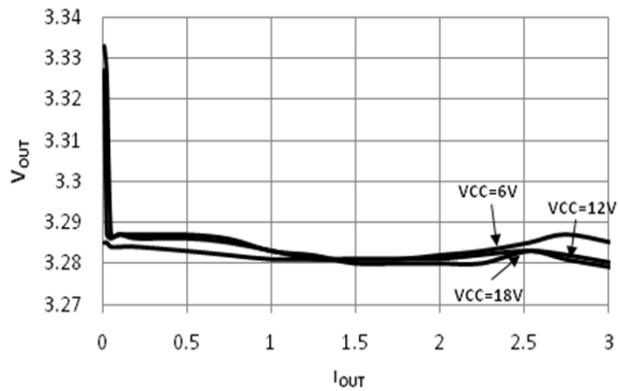

Figure 2.8 Line Regulation ($I_{OUT}=1A$)

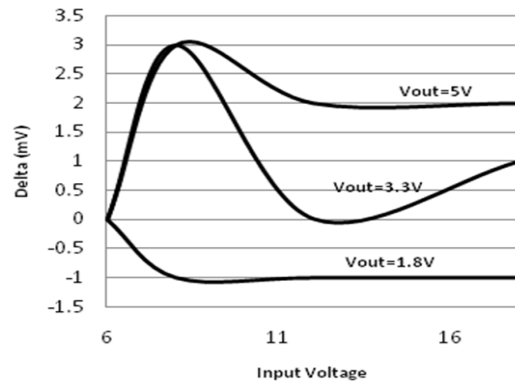

Figure 2.9 Efficiency vs. Output Current ($V_{OUT}=1.8V$)

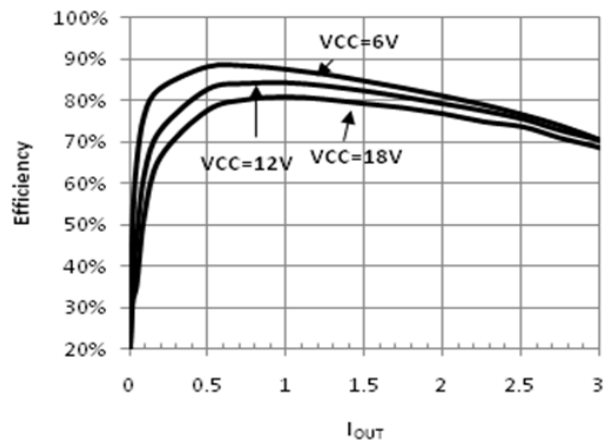

Figure 2.10 Efficiency vs. Output Current ($V_{OUT}=3.3V$)

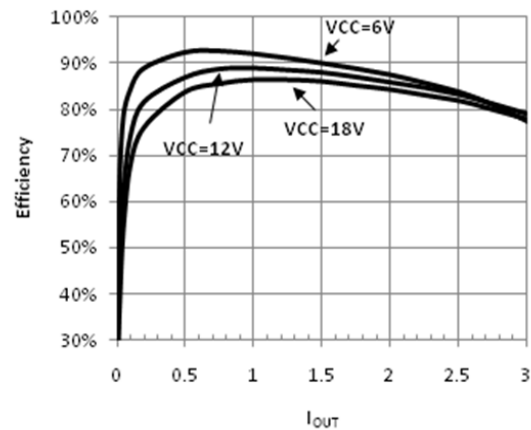

Figure 2.11 Efficiency vs. Output Current ($V_{OUT}=5V$)

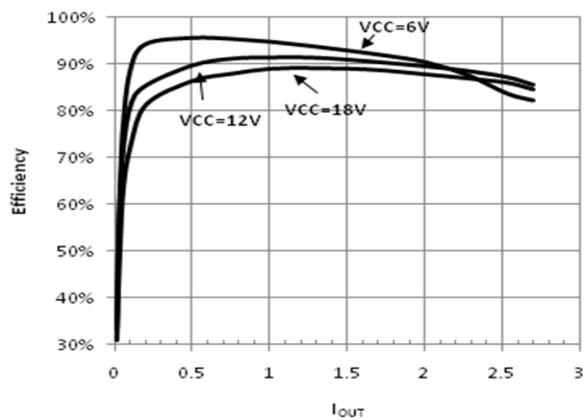
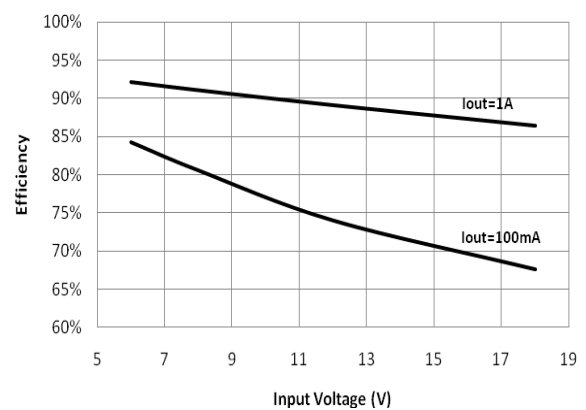

Figure 2.12 Efficiency vs. Input Voltage ($V_{OUT}=3.3V$)



ZSPM4013

High Efficiency 3A Synchronous Buck Converter

ZMDI[®]

The Analog Mixed Signal Company



Figure 2.13 Standby Current vs. Input Voltage

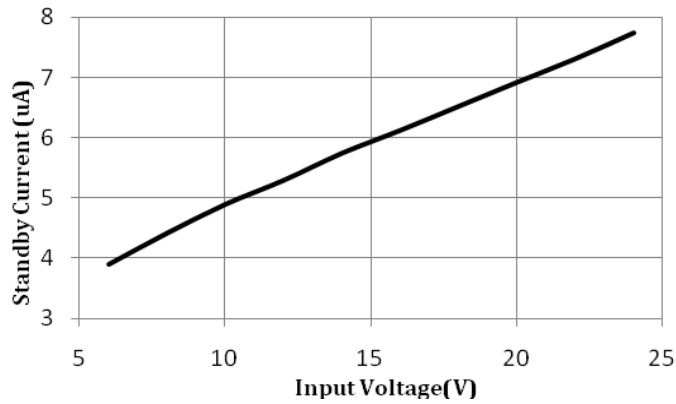

Figure 2.14 Standby Current vs. Temperature

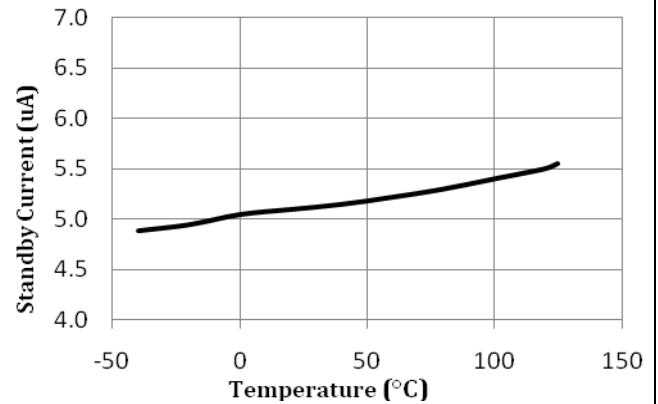

Figure 2.15 Output Voltage vs. Temperature

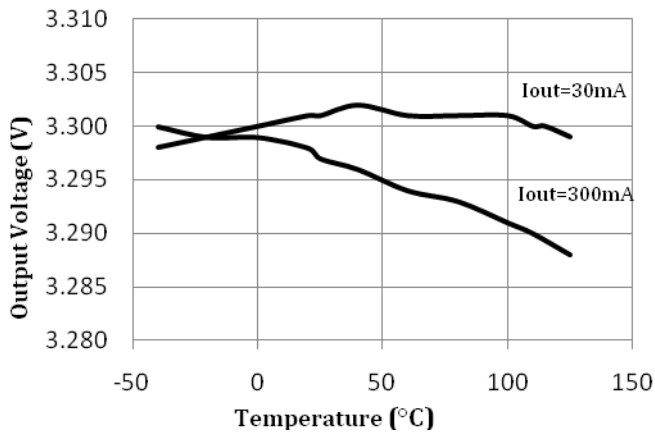

Figure 2.16 Oscillator Frequency vs. Temperature (Iout=300mA)

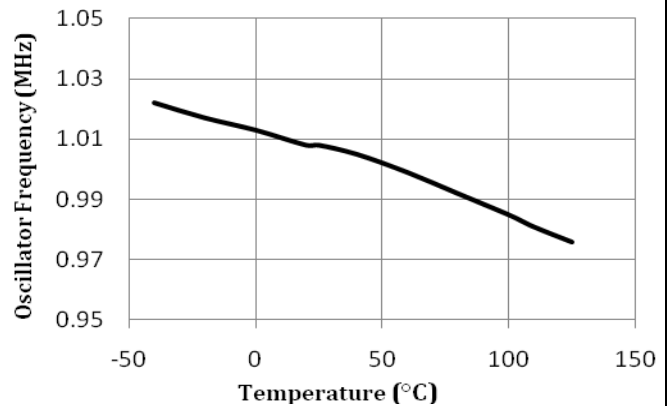

Figure 2.17 Quiescent Current vs. Temperature (No load)

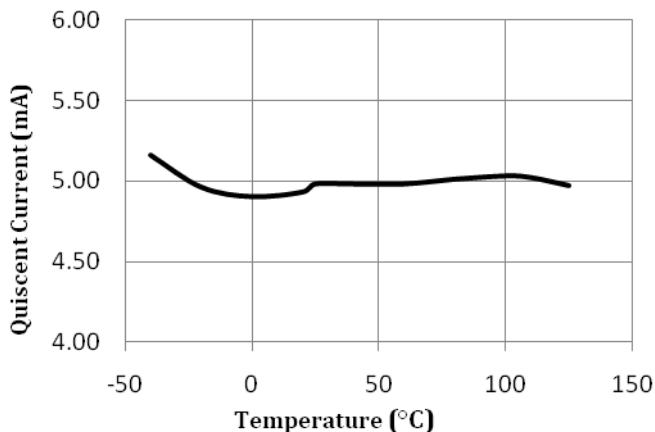
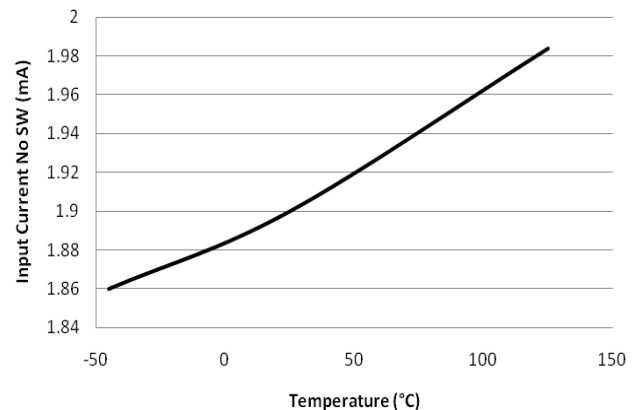

Figure 2.18 Input Current vs. Temperature (No load, No switching)



ZSPM4013

High Efficiency 3A Synchronous Buck Converter

ZMDI[®]

The Analog Mixed Signal Company



3 Description of Circuit

The ZSPM4013 current-mode synchronous step-down power supply product can be used in the commercial, industrial, and automotive market segments. It includes flexibility for a wide range of output voltages and is optimized for high efficiency power conversion with low $R_{\text{DS(on)}}$ integrated synchronous switches. A 1MHz internal switching frequency facilitates low-cost LC filter combinations. Additionally, the fixed-output versions enable a minimum external component count to provide a complete regulation solution with only 4 external components: an input bypass capacitor, an inductor, an output capacitor, and the bootstrap capacitor. The regulator automatically transitions between PFM and PWM mode to maximize efficiency for the load demand.

Figure 3.1 ZSPM4013 Block Diagram

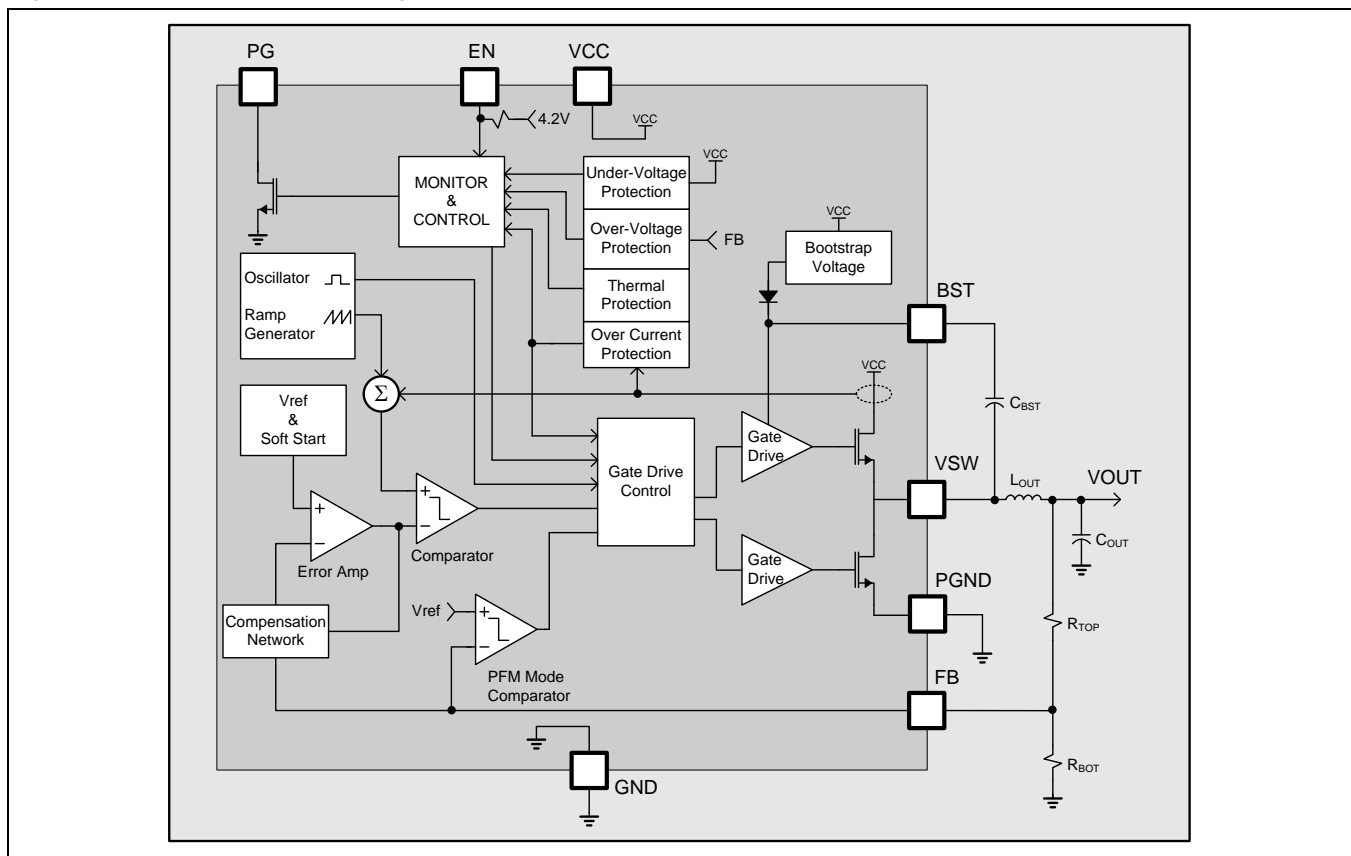

ZSPM4013

High Efficiency 3A Synchronous Buck Converter



Figure 3.2 Monitor and Control Logic Functionality

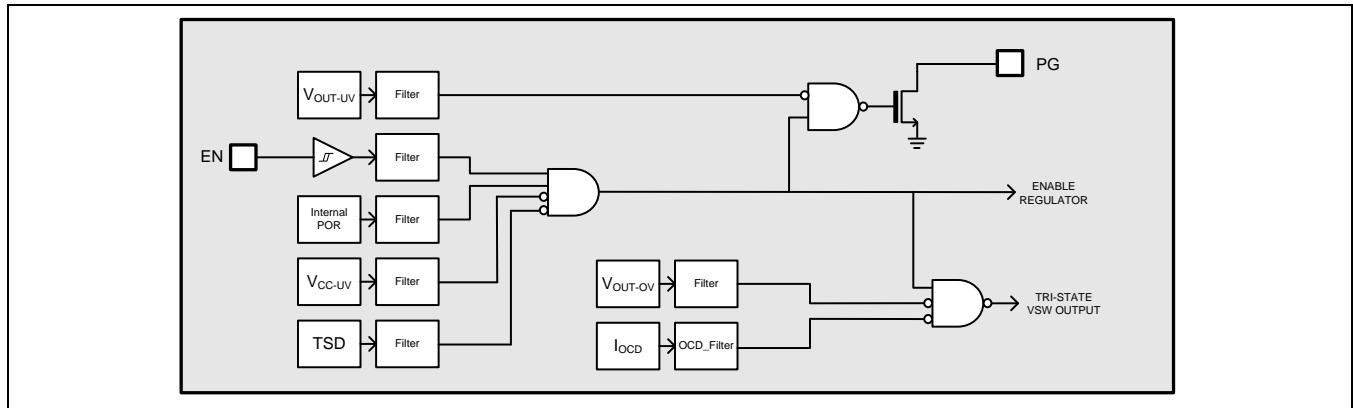

3.1. Internal Protection Details

3.1.1. Internal Current Limit

The current through the high side FET is sensed on a cycle-by-cycle basis, and if the current limit is reached, it will abbreviate the cycle. In addition, the device senses the FB pin to identify hard short conditions and will direct the VSW output to skip 4 cycles if the current limit occurs when FB is low. This allows current built up in the inductor during the minimum on time to decay sufficiently. The current limit is always active when the regulator is enabled. Soft start ensures that current limit does not prevent regulator startup.

An additional feature of the over-current protection circuitry is that under extended over-current conditions, the device will automatically disable. A simple toggle of the EN enable pin will return the device to normal operation.

3.1.2. Thermal Shutdown

If the temperature of the die exceeds 170°C (typical), the VSW outputs will tri-state to protect the device from damage. The PG and all other protection circuitry will stay active to inform the system of the failure mode. Once the ZSPM4013 cools to 160°C (typical), the device will attempt to start up again, following the normal soft start sequence. If the device reaches 170°C, the shutdown/restart sequence will repeat.

3.1.3. Reference Soft-Start

The reference in this device is ramped at a rate of 4ms to prevent the output from overshoot during startup. This ramp restarts whenever there is a rising edge sensed on the EN pin. This occurs in both the fixed and adjustable versions. During the soft start ramp, current limit is still active and still protects the device if the output is shorted.

3.1.4. Output Over-Voltage

If the output of the regulator exceeds 103% of the regulation voltage, the VSW outputs will tri-state to protect the ZSPM4013 from damage. This check occurs at the start of each switching cycle. If it occurs during the middle of a cycle, the switching for that cycle will complete and the VSW outputs will tri-state at the start of the next cycle.

3.1.5. VCC Under-Voltage Lockout

The ZSPM4013 is held in the off state until VCC reaches 5.75V (typical). There is hysteresis on this input (see section 1.4).

ZSPM4013

High Efficiency 3A Synchronous Buck Converter



4 Application Circuits

4.1. Selection of External Components

The internal compensation is optimized for a $44\mu\text{F}$ output capacitor and a $4.7\mu\text{H}$ inductor. The minimum allowable value for the output capacitor is $33\mu\text{F}$. To keep the output ripple low, a low ESR (less than $35\text{m}\Omega$) ceramic is recommended. The inductor range is $4.7\mu\text{H} \pm 20\%$. For optimal over-current protection, the inductor should be able to handle up to the regulator current limit without saturation.

Connect the VCC pin to the bypass capacitor C_{BYPASS} to improve performance (see section 5.3.1). See Table 1.3 for the recommended value.

Connect the BST pin to the bootstrap capacitor C_{BST} as described in section 5.3.2. See Table 1.3 for the recommended value.

4.2. Typical Application Circuits

Figure 4.1 Typical Application for Adjustable Output Voltage

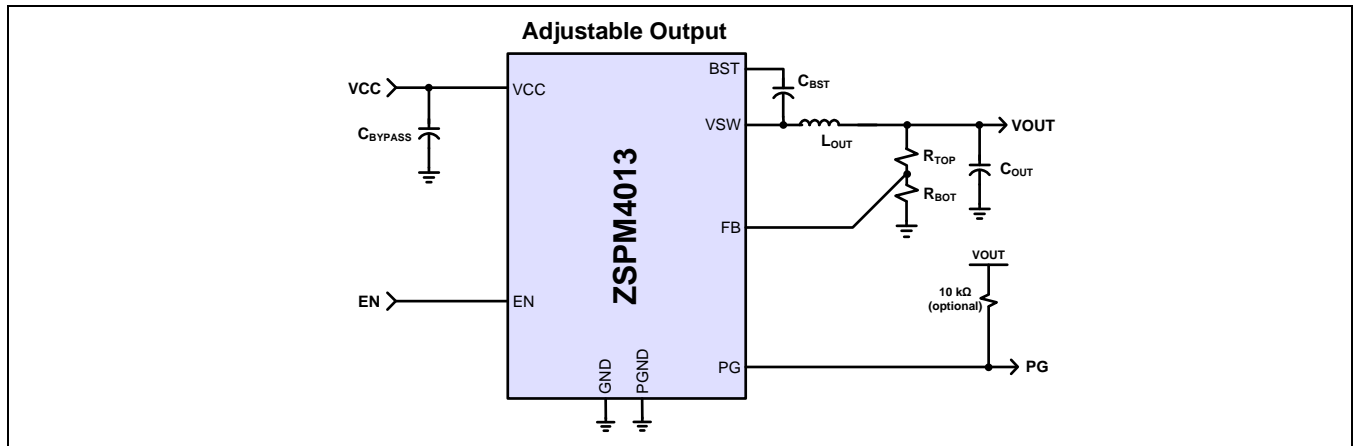
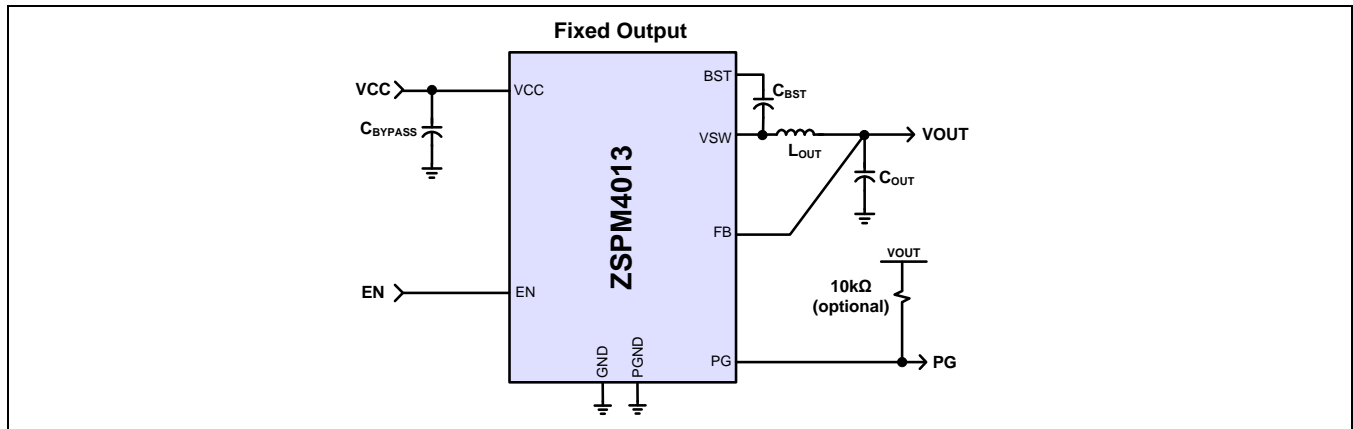

Figure 4.2 Typical Application for Fixed Output Voltage



ZSPM4013

High Efficiency 3A Synchronous Buck Converter

ZMDI[®]

The Analog Mixed Signal Company



5 Pin Configuration and Package

Figure 5.1 ZSPM4013 Package Drawing

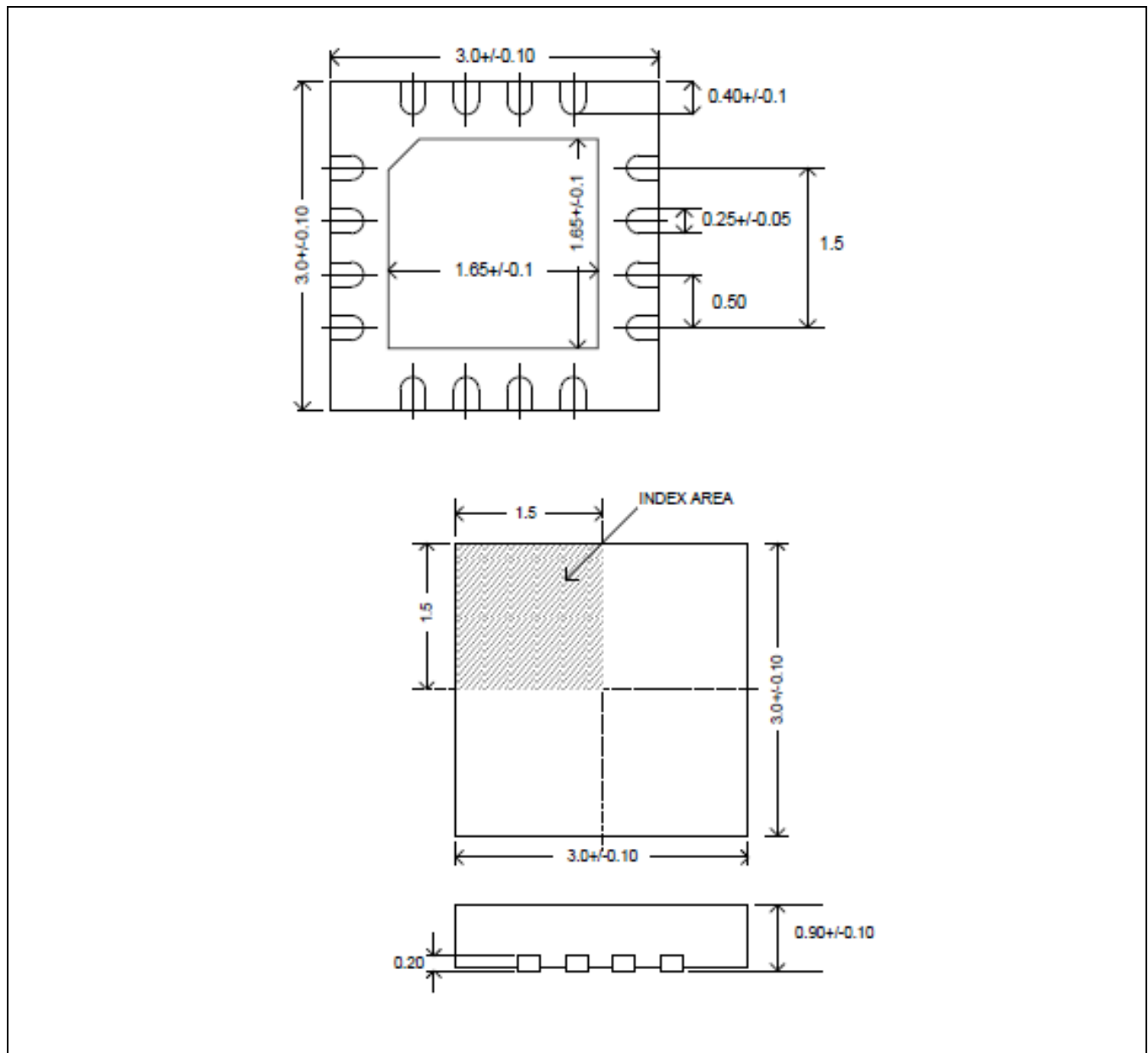

ZSPM4013

High Efficiency 3A Synchronous Buck Converter

ZMDI[®]

The Analog Mixed Signal Company



5.1. Marking Diagram & Pin-out

Figure 5.2 16 Lead 3x3mm QFN (top view)

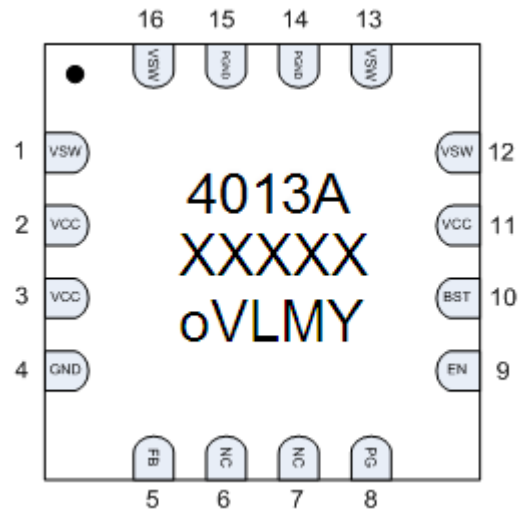

4013: Part Name

A: Revision

XXXXX: Lot number (last five digits)

O: Pin 1 mark

VL: Voltage level

- 15 1.5V
- 18 1.8V
- 25 2.5V
- 33 3.3V
- 50 5.0V
- 00 0.9V – 5.0V variable

MY: Date Code

M = Month

- 1 January
- 2 February
- 3 March
- 4 April
- 5 May
- 6 June
- 7 July
- 8 August
- 9 September
- A October
- B November
- C December

Y = Year

- A 2011
- B 2012
- C 2013
- Etc.

ZSPM4013

High Efficiency 3A Synchronous Buck Converter



The Analog Mixed Signal Company



5.2. Pin Description for 16 LEAD 3x3mm QFN

Table 5.1 Pin Description, 16 lead, 3x3mm QFN

Name	Pin #	Function	Description
VSW	1	Switching Voltage Node	Connected to a 4.7 μ H (typical) inductor. Also connect to additional VSW pins 12, 13, and 16.
VCC	2	Input Voltage	Input voltage. Also connect to additional VCC pins 3 and 11.
VCC	3	Input Voltage	Input voltage. Also connect to additional VCC pins 2 and 11.
GND	4	GND	Primary ground for the majority of the device except the low-side power FET.
FB	5	Feedback Input	Regulator FB voltage. Connects to V_{OUT} for fixed-mode and the output resistor divider for adjustable mode.
NC	6	No Connect	Not connected.
NC	7	No Connect	Not connected.
PG	8	PG Output	Open-drain output.
EN	9	Enable Input	Above 2.2V the device is enabled. Ground this pin to disable the ZSPM4013. Includes internal pull-up.
BST	10	Bootstrap Capacitor	Bootstrap capacitor for the high-side FET gate driver. Connect a 22nF ceramic capacitor from BST pin to VSW pin.
VCC	11	Input Voltage	Input voltage. Also connect to additional VCC pins 2 and 3.
VSW	12	Switching Voltage Node	Connected to 4.7 μ H (typical) inductor. Also connect to additional VSW pins 1, 13, and 16.
VSW	13	Switching Voltage Node	Connected to 4.7 μ H (typical) inductor. Also connect to additional VSW pins 1, 12, and 16.
PGND	14	Power GND	GND supply for internal low-side FET/integrated diode. Also connect to additional PGND pin 15.
PGND	15	Power GND	GND supply for internal low-side FET/integrated diode. Also connect to additional PGND pin 14.
VSW	16	Switching Voltage Node	Connected to 4.7 μ H (typical) inductor. Also connect to additional VSW pins 1, 12, and 13.

ZSPM4013

High Efficiency 3A Synchronous Buck Converter



5.3. Detailed Pin Description

5.3.1. Unregulated Input, VCC (Pins # 2, 3)

This terminal is the unregulated input voltage source for the ZSPM4013. It is recommended that a 10 μ F bypass capacitor be placed close to the device for best performance. Since this is the main supply for the ZSPM4013, good layout practices must be followed for this connection.

5.3.2. Bootstrap Control, BST (Pin #10)

This terminal will provide the bootstrap voltage required for the upper internal NMOS switch of the buck regulator. An external ceramic capacitor placed between the BST input terminal, and the VSW pin will provide the necessary voltage for the upper switch. In normal operation, the capacitor is re-charged on every low side synchronous switching action. If the switch mode approaches 100% duty cycle for the high side FET, the device will automatically reduce the duty cycle switch to a minimum off time on every 8th cycle to allow this capacitor to re-charge.

5.3.3. Sense Feedback, FB (Pin #5)

This is the input terminal for the output voltage feedback. For the fixed-mode versions, this should be connected directly to V_{OUT} . The connection on the PCB should be kept as short as possible and should be made as close as possible to the capacitor. The trace should not be shared with any other connection. For adjustable-mode versions of the ZSPM4013, this should be connected to the external resistor divider. To choose the resistors, use the following equation:

$$V_{OUT} = 0.9 (1 + R_{TOP}/R_{BOT})$$

The input to the FB pin is high impedance, and input current should be less than 100nA. As a result, good layout practices are required for the feedback resistors and feedback traces. When using the adjustable version, the feedback trace should be kept as short and narrow as possible to reduce stray capacitance and the injection of noise.

5.3.4. Switching Output, VSW (Pins #12, 13)

This is the switching node of the regulator. It should be connected directly to the 4.7 μ H inductor with a wide, short trace and to one end of the bootstrap capacitor. It is switching between VCC and PGND at the switching frequency.

5.3.5. Ground, GND (Pin #4)

This ground is used for the majority of the device including the analog reference, control loop, and other circuits.

5.3.6. Power Ground, PGND (Pins #14, 15)

This is a separate ground connection used for the low-side synchronous switch to isolate switching noise from the rest of the device.

5.3.7. Enable, High-Voltage, EN (Pin #9)

This is the input terminal to activate the regulator. The input threshold is TTL/CMOS compatible. It also has an internal pull-up to ensure a stable state if the pin is disconnected.

5.3.8. Power Good Output, PG (Pin #8)

This is an open drain, active low output. The switched mode output voltage is monitored, and the PG line will remain low until the output voltage reaches the V_{OUT-UV} threshold. Once the internal comparator detects that the output voltage is above the desired threshold, an internal delay timer is activated and the PG line is de-asserted (to high) once this delay timer expires. In the event that the output voltage decreases below V_{OUT-UV} , the PG line will be asserted low and remain low until the output rises above V_{OUT-UV} and the delay timer times out. (See Figure 3.2.)

ZSPM4013

High Efficiency 3A Synchronous Buck Converter



6 Ordering Information

Ordering Code	Description	Package
ZSPM4013AA1W00	ZSPM4013, 3A Synchronous Buck Converter: adjustable output, 0.9V to 5V, 16-pin 3x3mm QFN	7" reel with 1000 ICs
ZSPM4013AA1W15	ZSPM4013, 3A Synchronous Buck Converter: fixed output, 1.5V, 16-pin 3x3mm QFN	7" reel with 1000 ICs
ZSPM4013AA1W18	ZSPM4013, 3A Synchronous Buck Converter: fixed output, 1.8V, 16-pin 3x3mm QFN	7" reel with 1000 ICs
ZSPM4013AA1W25	ZSPM4013, 3A Synchronous Buck Converter: fixed output, 2.5V, 16-pin 3x3mm QFN	7" reel with 1000 ICs
ZSPM4013AA1W33	ZSPM4013, 3A Synchronous Buck Converter: fixed output, 3.3V, 16-pin 3x3mm QFN	7" reel with 1000 ICs
ZSPM4013AA1W50	ZSPM4013, 3A Synchronous Buck Converter: fixed output, 5.0V, 16-pin 3x3mm QFN	7" reel with 1000 ICs
ZSPM4013KIT	ZSPM4013KIT, Evaluation Kit for 3A Synchronous Buck Converter	Kit

7 Related Documents

Document	File Name
ZSPM4013 Feature Sheet	ZSPM4013_Feature_Sheet_rev_X_xy.pdf
ZSPM4013 Evaluation Kit Description	ZSPM4013_12_13_Eval_Kit_Manual__X_xy.pdf

Note: X_xy denotes the current revision of the document. Visit ZMDI's website www.zmdi.com or contact your nearest sales office for the latest version of these documents.

8 Glossary

Term	Description
Buck converter	Step-down converter; converts a higher DC input voltage to a lower DC output voltage with high efficiency.
Synchronous Rectification	A technique for improving the efficiency of rectification by replacing diodes with actively controlled switches, such as transistors.
PWM	Pulse width modulation (fixed frequency).
PFM	Pulse frequency modulation (fixed pulse width).
ESR	Equivalent series resistance.
Bootstrap Control	When using an N-Channel Power MOSFET transistor as a high-side switch for the converter switching output, a gate voltage higher than the supply voltage is needed to turn the transistor fully on. For this purpose, a charge pump circuit, called the bootstrap control, is implemented to provide this high supply voltage for the high-side power MOSFET driver block.

ZSPM4013

High Efficiency 3A Synchronous Buck Converter



The Analog Mixed Signal Company



9 Document Revision History

Revision	Date	Description
1.00	23-Jan-2012	First release.
1.01	26-Jan-2012	Revision to delete note under Table 1.2.
1.02	17-Sep-2012	Correction of application circuits. PG can only be connected to VOUT through the optional resistor.
1.10	10-Oct-2012	Correction of specifications for operating voltage supply range in Table 1.3, in Table 1.4, and on page 2. Removed reference to "Dissipation Table" in Table 1.1. Update for Figure 2.6. Added instructions to connect duplicate pins in the pin description table. Revised block diagram graphic for block titled "Under and Over Voltage Protection" to read "Over-Voltage Protection." Removed reference to the R code in the part-ordering table in section 6. This option is not available. Revised reference to "Figure 2" in section 5.3.8 to refer to Figure 3.2. Update for contact information.

Sales and Further Information

www.zmdi.com

analog@zmdi.com

Zentrum Mikroelektronik Dresden AG
Grenzstrasse 28
01109 Dresden
Germany

ZMD America, Inc.
1525 McCarthy Blvd., #212
Milpitas, CA 95035-7453
USA

Zentrum Mikroelektronik Dresden AG, Japan Office
2nd Floor, Shinbashi Tokyu Bldg.
4-21-3, Shinbashi, Minato-ku
Tokyo, 105-0004
Japan

ZMD FAR EAST, Ltd.
3F, No. 51, Sec. 2,
Keelung Road
11052 Taipei
Taiwan

Zentrum Mikroelektronik Dresden AG, Korea Office
U-space 1 Building
11th Floor, Unit JA-1102
670 Sampyeong-dong
Bundang-gu, Seongnam-si
Gyeonggi-do, 463-400
Korea

Phone +49.351.8822.7.776
Fax +49.351.8822.8.7776

Phone 855-ASK-ZMDI
(855-275-9634)

Phone +81.3.6895.7410
Fax +81.3.6895.7301

Phone +886.2.2377.8189
Fax +886.2.2377.8199

Phone +82.31.950.7679
Fax +82.504.841.3026

DISCLAIMER: This information applies to a product under development. Its characteristics and specifications are subject to change without notice. Zentrum Mikroelektronik Dresden AG (ZMD AG) assumes no obligation regarding future manufacture unless otherwise agreed to in writing. The information furnished hereby is believed to be true and accurate. However, under no circumstances shall ZMD AG be liable to any customer, licensee, or any other third party for any special, indirect, incidental, or consequential damages of any kind or nature whatsoever arising out of or in any way related to the furnishing, performance, or use of this technical data. ZMD AG hereby expressly disclaims any liability of ZMD AG to any customer, licensee or any other third party, and any such customer, licensee and any other third party hereby waives any liability of ZMD AG for any damages in connection with or arising out of the furnishing, performance or use of this technical data, whether based on contract, warranty, tort (including negligence), strict liability, or otherwise.

Data Sheet
October 10, 2012

© 2012 Zentrum Mikroelektronik Dresden AG — Rev. 1.10
All rights reserved. The material contained herein may not be reproduced, adapted, merged, translated, stored, or used without the prior written consent of the copyright owner. The information furnished in this publication is subject to changes without notice.

21 of 21

X-ON Electronics

Largest Supplier of Electrical and Electronic Components

Click to view similar products for [Voltage Regulators - Switching Regulators](#) category:

Click to view products by [ZMDI](#) manufacturer:

Other Similar products are found below :

[LX7186A](#) [622616F](#) [632259F](#) [FAN53610AUC33X](#) [MP2148GQD-33-P](#) [MP2374DS-LF-Z](#) [EN6310QA](#) [NCP81108MNTXG](#)
[NCP81109BMNTXG](#) [L79M05TL-E](#) [FAN48610BUC45X](#) [R3](#) [LV5710GP-TE-L-H](#) [430464BB](#) [455605G](#) [AZ7500BMTR-E1](#) [MIC23156-](#)
[0YML-T5](#) [MIC4930YFL-T5](#) [MP8763GLE-P](#) [KE177614](#) [418569H](#) [455596X](#) [511087D](#) [030908C](#) [063375FB](#) [067501FB](#) [099508GB](#)
[EP5358LUA](#) [NCP81102MNTXG](#) [715715H](#) [FAN48611UC53X](#) [FAN53611AUC12X](#) [MAX809TTR](#) [MAX77596ETBC+T](#)
[MAX77596ETBB+T](#) [MAX16905AUE/V+](#) [NCP6332CMTAATBG](#) [NCV890203MWTXG](#) [LX7176A](#) [MP2162AGQH-Z](#) [MAX17544ATP+T](#)
[EN6360QI](#) [MCP1623T-IMC](#) [MCP1642B-18IMC](#) [MCP1642BT-30I/MS](#) [MCP1642D-50IMC](#) [MCP1642D-50IMS](#) [MCP1642D-ADJIMC](#)
[MC34063LBBGEVB](#) [MCP1252T-33X50IMS](#)