

# MB86R01

## DATA SHEET

---

July, 2009 the 1.4 edition



## Trademarks

ARM is a registered trademark of ARM Limited in UK, USA and Taiwan.

ARM is a trademark of ARM Limited in Japan and Korea.

ARM926EJ-S and ETM9 are trademarks of ARM Limited.

- The contents of this document are subject to change without notice.  
Customers are advised to consult with sales representatives before ordering.
- The information, such as descriptions of function and application circuit examples, in this document are presented solely for the purpose of reference to show examples of operations and uses of FUJITSU MICROELECTRONICS device; FUJITSU MICROELECTRONICS does not warrant proper operation of the device with respect to use based on such information. When you develop equipment incorporating the device based on such information, you must assume any responsibility arising out of such use of the information. FUJITSU MICROELECTRONICS assumes no liability for any damages whatsoever arising out of the use of the information.
- Any information in this document, including descriptions of function and schematic diagrams, shall not be construed as license of the use or exercise of any intellectual property right, such as patent right or copyright, or any other right of FUJITSU MICROELECTRONICS or any third party or does FUJITSU MICROELECTRONICS warrant non-infringement of any third-party's intellectual property right or other right by using such information. FUJITSU MICROELECTRONICS assumes no liability for any infringement of the intellectual property rights or other rights of third parties which would result from the use of information contained herein.
- The products described in this document are designed, developed and manufactured as contemplated for general use, including without limitation, ordinary industrial use, general office use, personal use, and household use, but are not designed, developed and manufactured as contemplated (1) for use accompanying fatal risks or dangers that, unless extremely high safety is secured, could have a serious effect to the public, and could lead directly to death, personal injury, severe physical damage or other loss (i.e., nuclear reaction control in nuclear facility, aircraft flight control, air traffic control, mass transport control, medical life support system, missile launch control in weapon system), or (2) for use requiring extremely high reliability (i.e., submersible repeater and artificial satellite).  
Please note that FUJITSU MICROELECTRONICS will not be liable against you and/or any third party for any claims or damages arising in connection with above-mentioned uses of the products.
- Any semiconductor devices have an inherent chance of failure. You must protect against injury, damage or loss from such failures by incorporating safety design measures into your facility and equipment such as redundancy, fire protection, and prevention of over-current levels and other abnormal operating conditions.
- Exportation/release of any products described in this document may require necessary procedures in accordance with the regulations of the Foreign Exchange and Foreign Trade Control Law of Japan and/or US export control laws.
- The company names and brand names herein are the trademarks or registered trademarks of their respective owners.

All rights reserved, Copyright FUJITSU MICROELECTRONICS LIMITED 2007 - 2009

## Revision History

Date	Ver.	Contents
2007/07/12	1.0	Newly issued
2007/08/20	1.1	8.3.1. Recommended Power On/Off Sequence <ul style="list-style-type: none"> <li>• Revised the last line of description (PLL reference clock part)</li> </ul> 8.4.3. ADC <ul style="list-style-type: none"> <li>• Revised value of table 8-16</li> <li>• Revised and deleted descriptive content of note</li> <li>• Revised footnote (*2) of table 8-17</li> </ul> 8.4.4. I <sup>2</sup> C Bus Fast Mode I/O <ul style="list-style-type: none"> <li>• Revised table 8-18 and footnote</li> <li>• Deleted footnote (*3)</li> </ul> 8.5.9. I <sup>2</sup> C Bus Timing <ul style="list-style-type: none"> <li>• Revised footnote (*2) of table 8-37</li> </ul> 8.5.12. MLB Signal Timing <ul style="list-style-type: none"> <li>• Revised MLB to MediaLB</li> <li>• Revised footnote of table 8-42, 8-45</li> </ul>
2007/11/09	1.2	4. Function list <ul style="list-style-type: none"> <li>• Revised contents of the list</li> </ul> 6. Pin assignment <ul style="list-style-type: none"> <li>• Revised figures in 1-8/1-9 pages</li> <li>• Added "top view" statement</li> </ul> 7.1. Pin Multiplex <ul style="list-style-type: none"> <li>• Revised description of note</li> <li>• Added mode setting description to pin multiplex group #1 ~ #5</li> <li>• Revised table of pin multiplex group #2 and #4</li> </ul> 7.2.4. USB 2.0 Host/Function related pin <ul style="list-style-type: none"> <li>• Revised description of USB_EXT12K pin</li> </ul> 7.2.5. External interrupt controller related pin <ul style="list-style-type: none"> <li>• Revised title</li> </ul> 7.2.12. A/D converter related pin <ul style="list-style-type: none"> <li>• Revised pin name: AD_AVD0 → AD_AVD, AD_AVS1 → AD_AVS</li> </ul> 7.2.24. Unused pin <ul style="list-style-type: none"> <li>• Added this section</li> </ul> 7.2.25. Unused pin with pin multiplex function in the duplex case <ul style="list-style-type: none"> <li>• Added this section</li> </ul> 8.4.2. DDR2SDRAM IF I/O (SSTL_18) <ul style="list-style-type: none"> <li>• Revised table 8-12</li> </ul> 8.5.1. Memory Controller Signal Timing <ul style="list-style-type: none"> <li>• Revised table 8-21</li> <li>• Revised figure 8-8 and 8-9</li> <li>• Added figure 8-10, 8-11, and 8-12</li> </ul> 8.5.6.2. Input Signal <ul style="list-style-type: none"> <li>• Revised figure 8-23</li> </ul>
2008/02/07	1.3	6. Pin assignment <ul style="list-style-type: none"> <li>• Revised figure and table</li> </ul> 7.2.2. IDE66 related pin <ul style="list-style-type: none"> <li>• Revised type</li> <li>• Revised status pin after reset</li> </ul> 7.2.3. SD memory controller related pin <ul style="list-style-type: none"> <li>• Unified SD_DAT[0] and SD_DAT[3:1]</li> </ul> 7.2.7. CAN related pin <ul style="list-style-type: none"> <li>• Revised type</li> </ul>

Date	Ver.	Contents
2008/02/07	1.3	7.2.8. I2S related pin <ul style="list-style-type: none"> <li>• Revised type</li> <li>• Revised status pin after reset</li> </ul> 7.2.10. SPI related pin <ul style="list-style-type: none"> <li>• Revised type</li> </ul> 7.2.11. PWM related pin <ul style="list-style-type: none"> <li>• Revised type</li> <li>• Added comment</li> </ul> 7.2.13. DDR2 related pin <ul style="list-style-type: none"> <li>• Revised resistance value of *2</li> </ul> 7.2.15. Video captured related pin <ul style="list-style-type: none"> <li>• Revised type</li> <li>• Added comment</li> </ul> 7.2.18. ICE related pin <ul style="list-style-type: none"> <li>• Revised status pin after reset of XSRST</li> </ul> 7.2.20. ETM related pin <ul style="list-style-type: none"> <li>• Revised pin name in description column of TRACECLK</li> </ul> 7.2.22. MediaLB related pin <ul style="list-style-type: none"> <li>• Revised pin name</li> <li>• Revised type</li> </ul> 7.2.24. Unused pin <ul style="list-style-type: none"> <li>• Revised process</li> <li>• Deleted BIGEND</li> <li>• Revised pin name of B17, B16, C17, C16, and D16</li> </ul> 7.2.25. Unused pin with pin multiplex function in the duplex case <ul style="list-style-type: none"> <li>• Revised process</li> </ul> 8.1. Maximum Ratings <ul style="list-style-type: none"> <li>• Revised table 8-1</li> </ul>
2009/07/07	1.4	7.2.14. DISPLAY related pin <ul style="list-style-type: none"> <li>• Added note</li> </ul> 8.1. Maximum Ratings <ul style="list-style-type: none"> <li>• Revised table 8-1</li> </ul> 8.3.2. Power On Reset <ul style="list-style-type: none"> <li>• Revised figure 8-3</li> <li>• Revised description</li> </ul> 8.5.5.1. Clock <ul style="list-style-type: none"> <li>• Revised table 8-28</li> </ul> 8.5.7. I2S Signal Timing <ul style="list-style-type: none"> <li>• Revised table 8-34 and 8-35</li> </ul> 8.5.10. SPI Signal Timing <ul style="list-style-type: none"> <li>• Revised table 8-38</li> </ul>

# Contents

<b>1. Outline .....</b>	<b>1</b>
<b>2. Feature.....</b>	<b>1</b>
<b>3. Block diagram .....</b>	<b>2</b>
<b>4. Function list .....</b>	<b>4</b>
<b>5. Package dimension .....</b>	<b>6</b>
<b>6. Pin assignment .....</b>	<b>7</b>
<b>7. Pin function.....</b>	<b>10</b>
7.1. Pin Multiplex.....	10
7.2. Pin Function .....	16
7.2.1. External bus interface related pin .....	17
7.2.2. IDE66 related pin .....	17
7.2.3. SD Memory controller related pin.....	18
7.2.4. USB 2.0 Host/Function related pin .....	18
7.2.5. External interrupt controller related pin .....	18
7.2.6. UART related pin .....	19
7.2.7. CAN related pin .....	19
7.2.8. I2S related pin .....	19
7.2.9. I <sup>2</sup> C related pin .....	20
7.2.10. SPI related pin .....	20
7.2.11. PWM related pin .....	20
7.2.12. A/D converter related pin .....	20
7.2.13. DDR2 related pin .....	21
7.2.14. DISPLAY related pin .....	22
7.2.15. Video capture related pin.....	23
7.2.16. System related pin .....	23
7.2.17. JTAG related pin .....	23
7.2.18. ICE related pin .....	24
7.2.19. Multiplex setting related pin .....	24
7.2.20. ETM related pin .....	24
7.2.21. Power supply related pin .....	24
7.2.22. MediaLB related pin.....	25
7.2.23. GPIO related pin .....	25
7.2.24. Unused pin .....	26
7.2.25. Unused pin with pin multiplex function in the duplex case .....	34
<b>8. Electrical Characteristics.....</b>	<b>35</b>
8.1. Maximum Ratings.....	35

8.2.	Recommended Operating Conditions .....	37
8.3.	Precautions at Power On .....	38
8.3.1.	Recommended Power On/Off Sequence .....	38
8.3.2.	Power On Reset .....	39
8.4.	DC Characteristics .....	40
8.4.1.	3.3V Standard CMOS I/O .....	40
8.4.1.1.	3.3V Standard CMOS I/O V-I Characteristic (Driving Capability 1) .....	41
8.4.1.2.	3.3V Standard CMOS I/O V-I Characteristic (Driving Capability 2) .....	42
8.4.1.3.	3.3V Standard CMOS I/O V-I Characteristics (Driving Capability 3) .....	43
8.4.2.	DDR2SDRAM IF I/O (SSTL_18) .....	44
8.4.3.	ADC .....	46
8.4.4.	I <sup>2</sup> C Bus Fast Mode I/O .....	47
8.4.4.1.	I <sup>2</sup> C IO V-1 Characteristic Figure .....	48
8.4.5.	USB2.0 .....	49
8.5.	AC CHARACTERISTIC .....	50
8.5.1.	Memory Controller Signal Timing .....	50
8.5.2.	DDR2SDRAM IF .....	54
8.5.2.1.	DDR2SDRAM IF Timing Diagram .....	55
8.5.3.	GPIO Signal Timing .....	58
8.5.4.	PWM Signal Timing .....	59
8.5.4.1.	Output Signal .....	59
8.5.5.	GDC Display Signal Timing .....	60
8.5.5.1.	Clock .....	60
8.5.5.2.	Input Signal .....	60
8.5.5.3.	Output Signal .....	61
8.5.6.	GDC Video Capture Signal Timing .....	63
8.5.6.1.	Clock .....	63
8.5.6.2.	Input Signal .....	63
8.5.7.	I2S Signal Timing .....	65
8.5.8.	UART Signal Timing .....	67
8.5.9.	I <sup>2</sup> C Bus Timing .....	68
8.5.10.	SPI Signal Timing .....	69
8.5.11.	CAN Signal Timing .....	70
8.5.12.	MediaLB Signal Timing .....	71
8.5.12.1.	MediaLB AC Spec Type A .....	71
8.5.12.1.1.	Clock .....	71
8.5.12.1.2.	Input Signal .....	71
8.5.12.1.3.	Output Signal .....	71
8.5.12.2.	MediaLB AC Spec Type B .....	72
8.5.12.2.1.	Clock .....	72
8.5.12.2.2.	Input Signal .....	72
8.5.12.2.3.	Output signal .....	72
8.5.13.	USB2.0 Signal Timing .....	74
8.5.14.	IDE66 Signal Timing .....	76
8.5.14.1.	IDE PIO Timing .....	76
8.5.14.2.	IDE Ultra DMA Timing .....	78
8.5.15.	SD Signal Timing .....	80
8.5.15.1.	Clock .....	80
8.5.15.2.	Input/Output Signal .....	80
8.5.16.	ETM9 Trace Port Signal Timing .....	81
8.5.17.	EXIRC Signal Timing .....	82

## 1. Outline

MB86R01 is LSI product for the graphics applications with ARM Limited's CPU ARM926EJ-S and Fujitsu's GDC MB86296 as its core. This product contains peripheral I/O resources, such as in-vehicle LAN, HDD, and USB; therefore only a single chip of MB86R01 controls main graphics application system which usually requires 2 chips (CPU and GDC.)

## 2. Feature

- CMOS 90nm technology
- Package: PBGA484
- Power-supply voltage: (IO:  $3.3 \pm 0.3V$ , core:  $1.2 \pm 0.1V$ , DDR2:  $1.8 \pm 0.1V$ )
- Operation frequency: 333MHz (CPU), 83MHz (AHB), 41.5MHz (APB)
- CPU core
  - ARM926EJ-S
  - 16KB instruction cache/16KB data cache
  - 16KB ITCM/16KB DTCM
  - ETM9CS Single and JTAG ICE interface
  - Java acceleration (Jazelle technology)
- Bus architecture
  - Multi-layer AHB bus architecture
- Interrupt
- Built-in SRAM
- Clock/Reset control function
- Remap/Boot control function
- 16 bit external bus interface with decoding engine
- 32 bit DDR2 memory interface (target: 166MHz: 333Mbps)
- Graphics display controller
  - 2D/3D rendering engine of Fujitsu MB86296
  - RGB66 video output  $\times$  1ch (extensible to RGB888 with using option I/O)
  - ITU RBT-656 video capture  $\times$  1ch (extensible to RGB666 with using option I/O)
- USB 2.0 host (HS/FS protocols)  $\times$  1ch
- IDE66 (ATA/ATAPI-5)  $\times$  1ch
- SD memory interface (SDIO/CPRM: unsupported)  $\times$  1ch
- 10 bit A/D converter (1MS/s)  $\times$  2ch
- I<sup>2</sup>C (I/O voltage: 3.3V)  $\times$  2ch
- UART  $\times$  3ch (extensible up to 6ch with using option I/O)
- 32/16 bit timer  $\times$  2ch
- DMAC  $\times$  8ch

### Option I/O (with pin multiplex)

- RGB666 video output is extensible to 2ch
- Video capture is extensible to 2ch
- MediaLB (MOST50)  $\times$  1ch is addable
- CAN (I/O voltage: 3.3V)  $\times$  2ch is addable
- USB 2.0 function (HS/FS protocols) is switchable (USB 2.0 function and USB 2.0 host are accessed exclusively)
- GPIO is addable up to 24
- SPI  $\times$  1ch is addable
- PWM  $\times$  2ch is addable

- I2S is addable up to 3ch
- The number of UART channel is extensible up to 6ch
- The data width in the external bus interface is extensible to 32 bit

### 3. Block diagram

Figure 3-1 shows block diagram of MB86R01.

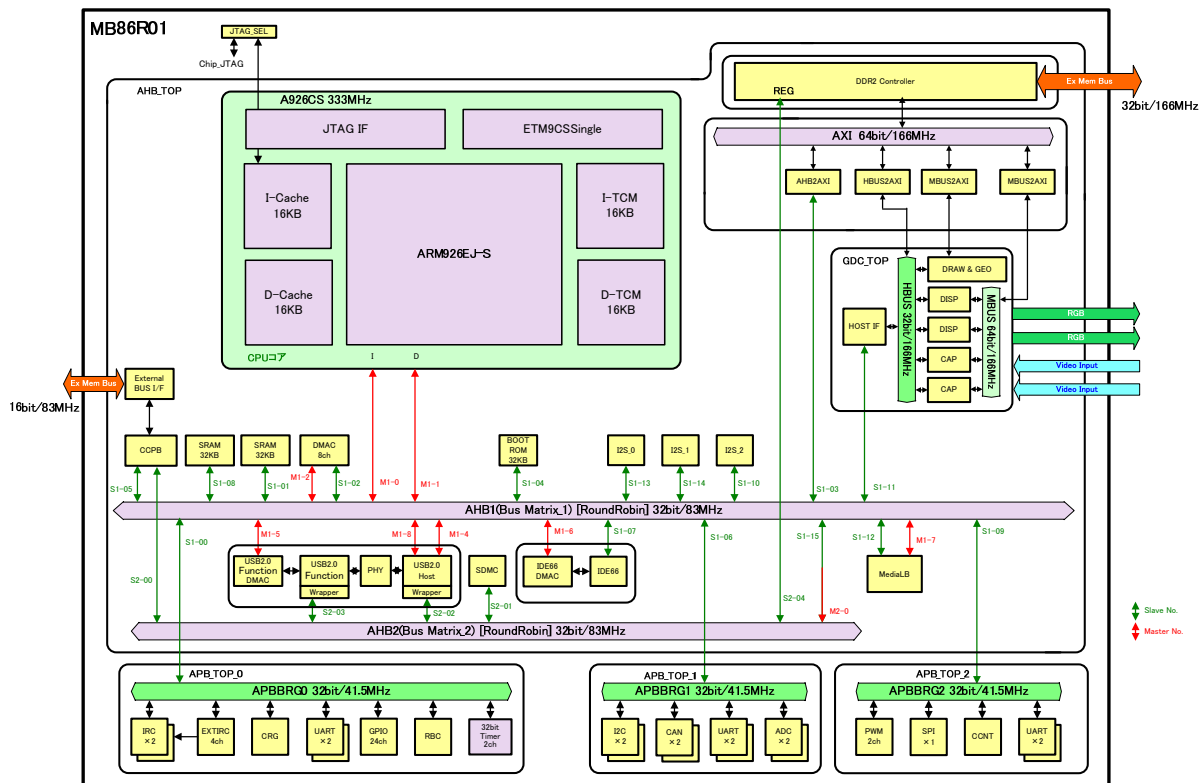

Figure 3-1 Block diagram of MB86R01

#### CPU core

This is CPU core block of ARM926EJ-S which is connected to each I/O through AHB bus in LSI. Instruction (I)/Data (D) function as a separate bus master for Harvard architecture.

#### GDC\_TOP

This is MB86296 compatible GDC which has 2 functions: AHB slave function writes required display list for drawing to GDC with having CPU or DMA controller as master, and AXI master function reads display list arranged in DDR2 memory with having GDC as master.

#### AXI bus

This bus bridges main memory and internal resource. Following four bus masters are connected.

- AHB1: Each bus master of AHB bus such as CPU and DMA controller
- HBUS: HOST IF on GDC
- DRAW & GEO: Draw (2D/3D drawing) and GEO (geometry engine) on GDC
- MBUS: DISP (display controller) and CAP (Video capture) on GDC



### AHB1 bus

Following resources are connected.

- CPU core: Bus masters of instruction (I)/data (D)
- GDC: GDC register part
- AHB2AXI: AXI port for main memory access
- CCPB: Encrypted ROM decoding block
- External BUS I/F: External bus interface (connected through CCPB)
- SRAM: General purpose internal SRAM 32KB × 2
- DMAC: General purpose DMA × 8ch  
It operates as bus master at data transfer
- Boot ROM: Built-in boot ROM
- I2S\_0/1/2: Serial audio controller × 3ch
- USB 2.0 Function DMAC: USB function DMAC  
It operates as bus master at data transfer
- USB2.0 Host: It operates as USB2.0 EHCI, USB1.1 OHCI bus masters
- IDE66/IDE66DMAC: Register part of IDE host controller and built-in DMAC  
The DMAC part operates as bus master at data transfer
- MLB: MediaLB controller
- AHB2
- APBBRG0/1/2: AHB-APB bridge circuit × 3ch

### AHB2 bus

- CCPB: Encrypted ROM decoding block
- USB 2.0 Function: USB 2.0 function controller's register part
- USB 2.0 Host: USB 2.0 host controller's register part
- SDMC: SD memory controller
- DDR2 controller: DDR2 controller's register part

### APB\_TOP\_0

This block bridges between APBBRG0 bus and AHB1 bus, and following low-speed peripheral resources are connected.

- Interrupt controller (IRC) × 2ch
- External interrupt controller (EXTIRC)
- Clock reset generator (CRG)
- UART (ch0 and ch1) × 2ch
- Remap boot controller (RBC)
- 32 bit general-purpose timer (32 bit timer) × 2ch

### APB\_TOP\_1

This block bridges between APBBRG1 bus and AHB1 bus, and following low-speed peripheral resources are connected.

- I<sup>2</sup>C controller × 2ch
- CAN controller × 2ch
- UART (ch2 and ch3) × 2ch
- A/D converter (ADC) × 2ch

### APB\_TOP\_2

This block bridges between APBBRG2 bus and AHB1 bus, and following low-speed peripheral resources are connected.

- PWM controller (PWM)
- SPI controller (SPI)
- CCNT
- UART (ch4 and ch5) × 2ch

## 4. Function list

Function list of MB86R01 is shown below.

Function	Outline
CPU core	<ul style="list-style-type: none"> <li>• ARM926EJ-S™ processor core</li> <li>• Core operation frequency: 333MHz</li> <li>• 16KB instruction cache</li> <li>• 16KB data cache</li> <li>• Tightly-Coupled memory for 16KB instruction (ITCM)</li> <li>• Tightly-Coupled memory for 16KB data (DTCM)</li> <li>• ETM9CS Single and JTAG ICE debugging interface</li> <li>• Java acceleration (Jazelle technology)</li> </ul>
Bus architecture	<ul style="list-style-type: none"> <li>• Multilayer AHB bus architecture (software interrupt)</li> <li>• Speeding up data transfer between main memory and each bus master with 64 bit AXI bus</li> </ul>
Interrupt	<ul style="list-style-type: none"> <li>• High-speed interrupt × 1ch h (soft interrupt)</li> <li>• Normal interrupt × 64ch (external interrupt × 4ch + built-in internal interrupt × 60ch)</li> <li>• Up to 16 interrupt levels are settable by channel</li> </ul>
Clock	<ul style="list-style-type: none"> <li>• PLL multiplication: selectable from ×15 ~ 49</li> <li>• Operation frequency: 333MHz (CPU), 83MHz (AHB), 41.5MHz (APB)</li> <li>• Low power consumption mode (clock to ARM and module is stoppable)</li> </ul>
Reset	<ul style="list-style-type: none"> <li>• Hardware reset, software reset, and watchdog reset</li> </ul>
Remap	<ul style="list-style-type: none"> <li>• ROM area is able to be mapping to built-in SRAM area</li> </ul>
External bus interface	<ul style="list-style-type: none"> <li>• Three chip select signals</li> <li>• Provided 32M byte address space in each chip select</li> <li>• Supported 16/32 bit width SRAM/Flash ROM connection</li> <li>• Programmable weight controller</li> <li>• Encrypted ROM compound engine</li> </ul>
DDR2 controller	<ul style="list-style-type: none"> <li>• Supported DDR2SDRAM (DDR2-400)</li> <li>• Connectable capacity: 256 ~ 512M bit × 2 or 256 ~ 512M bit × 1</li> <li>• I/O width: Selectable from ×16/×32 bit</li> <li>• Max. transfer rate: 166MHz/333Mbps</li> </ul>
Built-in SRAM	<ul style="list-style-type: none"> <li>• Mounted general purpose SRAM of 32KB × 2 (32 bit bus)</li> </ul>
DMAC	<ul style="list-style-type: none"> <li>• AHB connection × 8ch</li> <li>• Transfer mode: Block, burst, and demand</li> </ul>
Timer	<ul style="list-style-type: none"> <li>• 32/16 bit programmable × 2 channels</li> </ul>
GPIO (*2)	<ul style="list-style-type: none"> <li>• Max. 24 is usable</li> <li>• Interrupt function</li> </ul>
PWM (*2)	<ul style="list-style-type: none"> <li>• Built-in 2 channels</li> <li>• Duty ratio and phase are configurable</li> </ul>
A/D converter	<ul style="list-style-type: none"> <li>• 10 bit successive approximation type A/D converter × 2ch</li> <li>• Sampling rate: 648KS/s (max. sampling plate)</li> <li>• Nonlinearity error: ± 2.0LSB (max.)</li> </ul>

Function	Outline
GDC (*1)	<ul style="list-style-type: none"> <li>• Display controller RGB666 or RGB888 output Max. resolution is 1024 × 768 Max. 6 layered display Max. 2 screen output</li> <li>• Digital video capture function BT.601, BT.656, and RGB666 Max. 2 inputs</li> <li>• Geometry engine (MB86296 compatible display list is usable)</li> <li>• 2D/3D drawing function (MB86296 compatible display list is usable)</li> </ul>
I2S (*2)	<ul style="list-style-type: none"> <li>• Audio output × 3ch (L/R)/Audio input × 3ch (L/R)</li> <li>• Supported three-wire serial (I2S, MSB-Justified) and serial PCM data transfer interface</li> <li>• Master/Slave operations are selectable</li> <li>• Resolution capability: Max. 32 bit/sample</li> </ul>
UART (*2)	<ul style="list-style-type: none"> <li>• Max. 6 channels (dedicated channel: 3ch, option: 3ch)</li> <li>• 1 channel: capable of input/output CTS/RTS signals</li> <li>• 8 bit pre-scaler for baud rate clock generation</li> <li>• Enabled DMA transfer</li> </ul>
I <sup>2</sup> C	<ul style="list-style-type: none"> <li>• 3.3V pin × 2ch</li> <li>• Supported standard mode (max. 100kbps)/high-speed mode (max. 400kbps)</li> </ul>
SPI (*2)	<ul style="list-style-type: none"> <li>• Full duplex/Synchronous transmission</li> <li>• Transfer data length: 1 bit unit (max. 32 bit) (programmable setting)</li> </ul>
CAN (*2)	<ul style="list-style-type: none"> <li>• Mounted BOSCH C_CAN module × 2ch</li> <li>• Conformed to CAN protocol version 2.0 part A and B</li> <li>• I/O voltage: 3.3V</li> </ul>
MediaLB (*2)	<ul style="list-style-type: none"> <li>• 16 channels</li> <li>• MediaLB clock speed: 256Fs/512Fs/1024Fs</li> <li>• Built-in 9K bit channel buffer</li> </ul>
USB (*2)	<ul style="list-style-type: none"> <li>• USB 2.0 compliant Host/Function controller × 1ch (pin multiplex)</li> <li>• HS/FS protocol support (supported VBus and isochronous transfer)</li> </ul>
IDE (*2)	<ul style="list-style-type: none"> <li>• Supported ATA/ATAPI-5</li> <li>• Equipped 1 channel</li> <li>• Supported primary IDE channel</li> <li>• Equipped transmission FIFO buffer (512 byte × 2) and reception FIFO buffer (512 byte × 2) for the ultra DMA transfer</li> <li>• Unsupported single word DMA and multiword DMA</li> </ul>
SDMC	<ul style="list-style-type: none"> <li>• Conformed to SD memory card physical layer specification 1.0</li> <li>• Equipped 1 channel</li> <li>• Supported SD memory card and multimedia card</li> <li>• Unsupported SPI mode, SDIO mode, and CPRM</li> </ul>
CCNT	<ul style="list-style-type: none"> <li>• Mode selection of multiplex pin group 2 and 4</li> <li>• Software reset control</li> <li>• AXI interconnection control (priority and WAIT setting)</li> </ul>
JTAG	<ul style="list-style-type: none"> <li>• Conformed to IEIEEE1149.1 (IEEE Standard Test Access Port and Boundary-Scan Architecture)</li> <li>• Supported JTAG ICE connection</li> </ul>

\*1: Number of layer of simultaneous display and number of output display as well as capture input for displaying in high resolution may be restricted due to data supply capacity of graphics memory (DDR2 controller).

\*2: A part of external pin functions of this LSI is multiplexed. Max. number of usable channel is limited by pin multiplex function setting.

## 5. Package dimension

Package dimension of MB86R01 is shown below.

### BGA-484P-M07

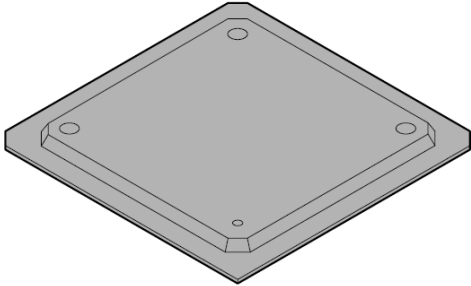
<p>484-pin plastic PBGA</p>  <p>(BGA-484P-M07)</p>	Ball pitch	1.00 mm
	Package width × package length	27.00 mm × 27.00 mm
	Lead shape	Ball
	Sealing method	Plastic mold
	Mounting height	2.36 mm Max

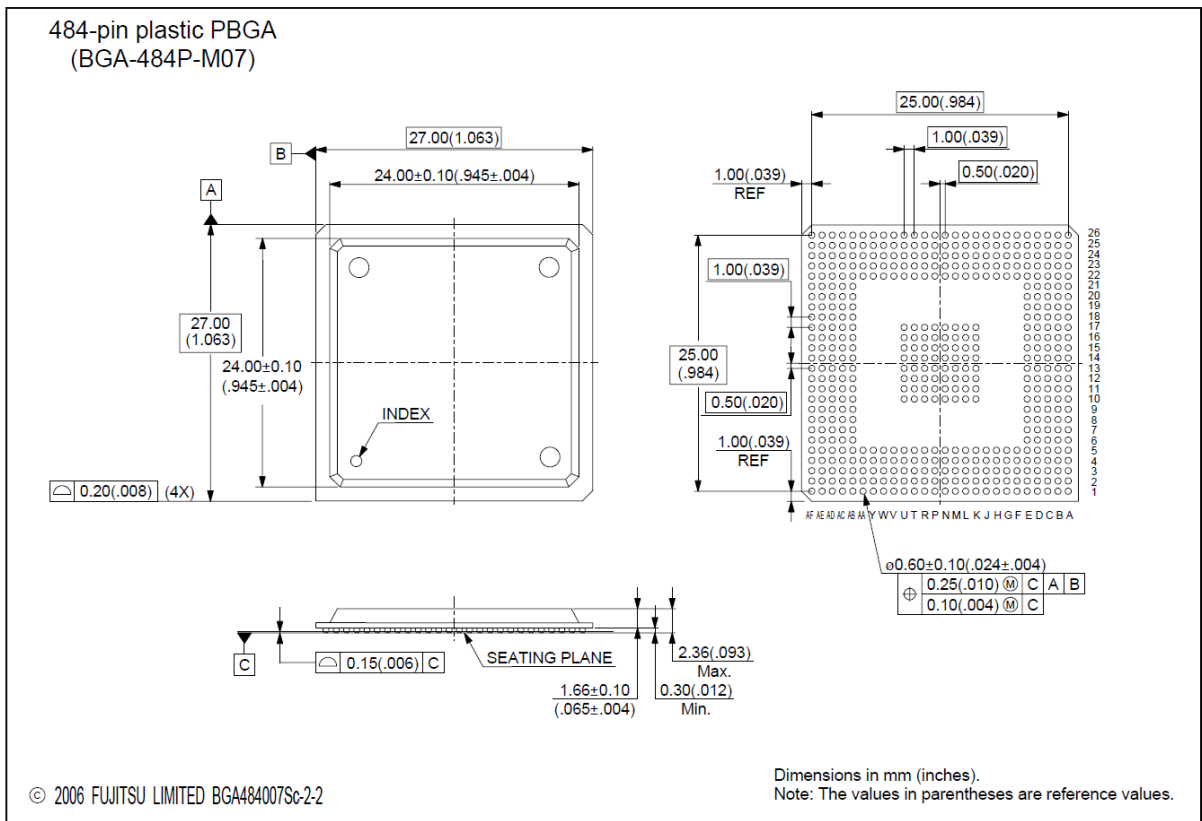

## 6. Pin assignment

Pin assignment of MB86R01 is shown below.

(Top view)

	1	2	3	4	5	6	7	8	9	10	11	12	13	14	15	16	17	18	19	20	21	22	23	24	25	26								
A	1	100	99	98	97	96	95	94	93	92	91	90	89	88	87	86	85	84	83	82	81	80	79	78	77	76								
B	2	101	192	191	190	189	188	187	186	185	184	183	182	181	180	179	178	177	176	175	174	173	172	171	170	75								
C	3	102	193	276	275	274	273	272	271	270	269	268	267	266	265	264	263	262	261	260	259	258	257	256	169	74								
D	4	103	194	277	352	351	350	349	348	347	346	345	344	343	342	341	340	339	338	337	336	335	334	255	168	73								
E	5	104	195	278	353	420	419	418	417	416	415	414	413	412	411	410	409	408	407	406	405	404	333	254	167	72								
F	6	105	196	279	354																	403	332	253	166	71								
G	7	106	197	280	355																	402	331	252	165	70								
H	8	107	198	281	356																	401	330	251	164	69								
J	9	108	199	282	357																	400	329	250	163	68								
K	10	109	200	283	358																	421	448	447	446	445	444	443	442	399	328	249	162	67
L	11	110	201	284	359																	422	449	468	467	466	465	464	441	398	327	248	161	66
M	12	111	202	285	360																	423	450	469	480	479	478	463	440	397	326	247	160	65
N	13	112	203	286	361																	424	451	470	481	484	477	462	439	396	325	246	159	64
P	14	113	204	287	362																	425	452	471	482	483	476	461	438	395	324	245	158	63
R	15	114	205	288	363																	426	453	472	473	474	475	460	437	394	323	244	157	62
T	16	115	206	289	364																	427	454	455	456	457	458	459	436	393	322	243	156	61
U	17	116	207	290	365																	428	429	430	431	432	433	434	435	392	321	242	155	60
V	18	117	208	291	366																								391	320	241	154	59	
W	19	118	209	292	367																								390	319	240	153	58	
Y	20	119	210	293	368																								389	318	239	152	57	
AA	21	120	211	294	369																								388	317	238	151	56	
AB	22	121	212	295	370	371	372	373	374	375	376	377	378	379	380	381	382	383	384	385	386	387	316	237	150	55								
AC	23	122	213	296	297	298	299	300	301	302	303	304	305	306	307	308	309	310	311	312	313	314	315	236	149	54								
AD	24	123	214	215	216	217	218	219	220	221	222	223	224	225	226	227	228	229	230	231	232	233	234	235	148	53								
AE	25	124	125	126	127	128	129	130	131	132	133	134	135	136	137	138	139	140	141	142	143	144	145	146	147	52								
AF	26	27	28	29	30	31	32	33	34	35	36	37	38	39	40	41	42	43	44	45	46	47	48	49	50	51								

(Top view)

	1	2	3	4	5	6	7	8	9	10	11	12	13	14	15	16	17	18	19	20	21	22	23	24	25	26		
A	VSS	VSS	DOLK00	VSS	DOLK00	DOUTG0 [6]	DOUTG0 [2]	DOUTB0 [4]	XSRST	TRACE DATA[3]	XRST	PLLSS	PLLVD0	TDO	VSS	CLK	MEM XRD	VSS	MEM EA[20]	MEM EA[16]	MEM EA[12]	MEM EA[8]	MEM EA[4]	MEM EA[1]	VSS	VSS		
B	VSS	DE0	HSYNG0	VDDE	DOUTR0 [4]	DOUTR0 [7]	DOUTG0 [3]	DOUTB0 [5]	XTRST	TRACE CTL	TRACE DATA[0]	TMS	VNTH0	CRIPM3	VDDE	MEM XCS[4]	MEM XWR[1]	MEM EA[23]	MEM EA[19]	MEM EA[15]	MEM EA[11]	MEM EA[7]	MEM EA[3]	MEM ED[15]	MEM ED[14]	VSS		
C	DOUTB1 [2]	GV0	VSYN0	DOUTR0 [7]	DOUTR0 [5]	DOUTR0 [2]	DOUTG0 [4]	DOUTB0 [6]	DOUTB0 [2]	TRACE CLK	TRACE DATA[1]	JTAGSEL	TCK	CRIPM2	CRIPM0	MEM XCS[2]	MEM XWR[0]	MEM EA[22]	MEM EA[18]	MEM EA[14]	MEM EA[10]	MEM EA[6]	MEM EA[2]	MEM ED[13]	MEM ED[12]	MEM ED[11]		
D	DOUTB1 [6]	DOUTB1 [5]	DOUTB1 [4]	DOUTB1 [3]	DOUTR0 [6]	DOUTR0 [3]	DOUTG0 [5]	DOUTB0 [7]	DOUTB0 [3]	RTCK	TRACE DATA[2]	LLTDTRS	TDI	CRIPM1	MEM RDY	MEM XCS[0]	MEM EA[24]	MEM EA[21]	MEM EA[17]	MEM EA[13]	MEM EA[9]	MEM EA[5]	MEM ED[10]	MEM ED[8]	MEM ED[7]	MEM ED[6]		
E	DOUTG1 [4]	DOUTG1 [3]	DOUTG1 [2]	DOUTB1 [7]	VDDE	VSS	VSS	VDDE	VDDE	VDDI	VDDI	VSS	VSS	VDDE	VDDE	VDDI	VDDI	VSS	VSS	VDDE	VDDE	VDDI	MEM ED[6]	MEM ED[5]	MEM ED[4]	MEM ED[3]		
F	DOUTR1 [2]	DOUTG1 [7]	DOUTG1 [6]	DOUTG1 [5]	VDDE																	VDDI	MEM ED[2]	MEM ED[1]	MEM ED[0]	VSS		
G	DOLK01	DOUTR1 [5]	DOUTR1 [4]	DOUTR1 [3]	VDDI																	VSS	MDQ[30]	MDM[3]	MDQ[31]	MDQ[30]		
H	VSS	VDDE	DOUTR1 [7]	DOUTR1 [6]	VDDI																	VSS	MDQ[25]	MDQ[28]	MDQ[24]	MDQ[25]		
J	DOLK01	GV1	VSYN0	HSYN0	VSS																	DDRVE	MDQ[27]	MDQ[26]	MDQ[29]	VSS		
K	VN0 [5]	VN0 [6]	VN0 [7]	DE1	VSS																		DDRVE	MDM[2]	MDQ[23]	VREF1	MDQ[26]	
L	VN0 [1]	VN0 [2]	VN0 [3]	VN0 [4]	VDDE																			DQ22	MDQ[20]	MDQ[17]	MDQ[16]	MDQ[20]
M	DOLK0	VDDE	VN VSYN0	VN0 [0]	VDDE																		VSS	MDQ[19]	MDQ[18]	MDQ[21]	VSS	
N	VSS	VINF00	VN VSYN0	VDDI	VDDI																		VDDI	ODT	VSS	DDRVE	MDQ[19]	
P	USB AVSP	USB AVDP	USB AVSFT	USB AVSB	USB AVDB																		VDDI	VSS	VSS	DDRVE	MDQ[19]	
R	USB HSDP	USB FSDP	USB AVDF1	USB AVSF2	USB EXT12K																		VDDI	VSS	VSS	VSS	VDDI	
T	USB HSDM	USB FSDM	USB AVSF1	USB AVSF2	USB AVSF2																		VDDI	VSS	VSS	VSS	VSS	
U	USB AVSF2	USB AVSF2	USB AVSF2	VSS	VDDI																		VDDI	VSS	VSS	VSS	DDRVE	
V	USB CRVCK48	USB MODE	VN1 [7]	VSS	VDDI																							
W	VN1 [6]	VN1 [5]	VN1 [4]	VN1 [3]	VDDE																							
Y	VSS	VN1 [2]	VN1 [1]	VN1 [0]	VDDE																							
AA	DOLK1	VDDE	VN VSYN0	VN VSYN0	VSS																							
AB	VINF01	I2S SD02	I2S SD2	I2S WS2	VSS	VDDE	VDDE	VDDI	VDDI	VSS	VSS	VDDE	AD VRL0	AD VRL1	VSS	VSS	VSS	VDDE	VDDE	VDDI	VDDI	DDRVE	MCS	MWE	MBA[0]	MBA[1]		
AC	I2S SCK2	PWM_01	IDE DIORDY	IDE DINTRQ	IDE DD[15]	IDE DD[11]	IDE DD[7]	IDE DD[3]	IDE DA[2]	IDE XDIOV	MPX MODE-1 [0]	TEST MODE[0]	AD VR0	AD VR1	VDDE	UART SN2	SD CLK	SD DAT[3]	VPD	INT_A [2]	SDRTPPE	DDTCON1	MA[0]	MA[2]	MA[10]	MA[1]		
AD	I2S ECLK2	PWM_00	IDE XBLD	IDE DMARQ	IDE DD[14]	IDE DD[10]	IDE DD[6]	IDE DD[2]	IDE DA[1]	IDE XDIOV	MPX MODE-1 [1]	PLL BYPASS	AD VN0	AD VN1	VDDE	UART SOUT2	SD CMD	SD DAT[2]	USB PRTWPR	I2C SDA0	INT_A [1]	TEST MODE[2]	MA[8]	MA[6]	MA[5]	MA[3]		
AE	VSS	VSS	IDE XDRSP	IDE XDDMAC	IDE DD[13]	IDE DD[9]	IDE DD[5]	IDE DD[1]	IDE DA[0]	IDE XDIOV	MPX MODE-5 [0]	BIGEND	AD VRH0	AD VRH1	UART XRTS0	UART SOUT0	UART SOUT1	SD DAT[1]	SD XNCD	I2C SDA1	INT_A [3]	MCKE STAFF	MA[13]	MA[4]	MA[11]	MA[7]		
AF	VSS	VSS	IDE XDRES16	IDE DRESET	IDE DD[12]	IDE DD[8]	IDE DD[4]	IDE DD[0]	IDE CSEL	IDE XDIOV	MPX MODE-5 [1]	TEST MODE[1]	AD AVD	AD AVS	UART SOUT0	UART SOUT0	UART SOUT1	SD DAT[0]	SD WP	I2C SCL1	I2C SDA1	INT_A [0]	MA[8]	MA[12]	VSS	VSS		



## 7. Pin function

External pin function of MB86R01 is described below.

### 7.1. Pin Multiplex

This LSI adopts pin multiplex function, and a part of external pin function is multiplexed.

The external pin function is categorized into following five groups. Each group is able to set the external pin function individually; therefore, the function can be flexibly set depending on the peripheral I/O resource to be used.

1. Pin multiplex group #1 (setting pin: MPX\_MODE\_1[1:0])
  - Mode 0: Pin related to DISPLAY1
  - Mode 1: Pin related to external bus interface
  - Mode 2: Pin related to I2S0, GPIO, and DISPLAY0 data width extension
2. Pin multiplex group #2 (setting register: CMUX\_MD.MPX\_MODE\_2[2:0])
  - Mode 0: Pin related to CAP1, CAP0 synchronizing signal, PWM, and I2S2
  - Mode 1: Pin related to CAP1 (NRGB666)
  - Mode 2: Pin related to GPIO, CAN, I2S1, MediaLB, and I2S2
  - Mode 3: Pin related to GPIO, CAN, I2S1, MediaLB, and SPI
  - Mode 4: Pin related to GPIO, CAN, I2S1, MediaLB, and I2S2 (input)
3. Pin multiplex group #3 (setting pin: USB\_MODE)
  - Mode 0: Pin related to USB 2.0 host
  - Mode 1: Pin related to USB 2.0 function
4. Pin multiplex group #4 (setting register: CMUX\_MD.MPX\_MODE\_4[1:0])
  - Mode 0: Pin related to IDE
  - Mode 1: Pin related to I2S1, CAN, GPIO, and PWM
5. Pin multiplex group #5 (setting pin: MPX\_MODE\_5[1:0])
  - Mode 0: Pin related to ETM
  - Mode 1: Pin related to UART3, UART4, and UART5
  - Mode 2: Pin related to UART3, UART4, and PWM

**Note:**

Mode should be changed when each pin is not in operation.

PWM, I2S1, and CAN pins may be duplicated and allocated to external pin depending on group combination; in this case, use either of them. For unused pin, follow the procedure in 1.6.27, unused pin with pin multiplex function in the duplex case.



**Pin multiplex group #1 (setting pin: MPX\_MODE\_1 [1:0])**

Pin No.	JEDEC	Mode 0	Mode 1	Mode 2			
		Pin related to DISPLAY1	Pin related to external bus interface	Pin related to I2S0	Pin related to GPIO	Pin related to DISPLAY0	Pin related to external bus interface
198	H3	DOUTr1[7]	MEM_ED[31]	I2S_ECLK0	-	-	-
281	H4	DOUTr1[6]	MEM_ED[30]	I2S_SCK0	-	-	-
106	G2	DOUTr1[5]	MEM_ED[29]	I2S_WS0	-	-	-
197	G3	DOUTr1[4]	MEM_ED[28]	I2S_SDIO	-	-	-
280	G4	DOUTr1[3]	MEM_ED[27]	I2S_SDO0	-	-	-
6	F1	DOUTr1[2]	MEM_ED[26]	-	GPIO_PD[12]	-	-
105	F2	DOUTG1[7]	MEM_ED[25]	-	GPIO_PD[11]	-	-
196	F3	DOUTG1[6]	MEM_ED[24]	-	GPIO_PD[10]	-	-
279	F4	DOUTG1[5]	MEM_ED[23]	-	GPIO_PD[9]	-	-
5	E1	DOUTG1[4]	MEM_ED[22]	-	GPIO_PD[8]	-	-
104	E2	DOUTG1[3]	MEM_ED[21]	-	GPIO_PD[7]	-	-
195	E3	DOUTG1[2]	MEM_ED[20]	-	GPIO_PD[6]	-	-
278	E4	DOUTB1[7]	MEM_ED[19]	-	-	DOUTr0[1]	-
4	D1	DOUTB1[6]	MEM_ED[18]	-	-	DOUTr0[0]	-
103	D2	DOUTB1[5]	MEM_ED[17]	-	-	DOUTG0[1]	-
194	D3	DOUTB1[4]	MEM_ED[16]	-	-	DOUTG0[0]	-
277	D4	DOUTB1[3]	MEM_XWR[3]	-	-	DOUTB0[1]	-
3	C1	DOUTB1[2]	MEM_XWR[2]	-	-	DOUTB0[0]	-
283	K4	DE1	XDACK[7]	-	-	-	XDACK[7]
282	J4	HSYNC1	DREQ[6]	-	-	-	DREQ[6]
199	J3	VSYNC1	XDACK[6]	-	-	-	XDACK[6]
108	J2	GV1	DREQ[7]	-	-	-	DREQ[7]

**Pin multiplex group #1 mode setting**

This mode is set with external pin, MPX\_MODE\_1[1:0].

MPX_MODE_1[1] pin	MPX_MODE_1[0] pin	Pin multiplex group #1 mode
"L"	"L"	Mode 0
"L"	"H"	Mode 1
"H"	"L"	Mode 2
"H"	"H"	Mode 0

**Pin multiplex group #2 (setting register: PIN MPX Select.MPX\_MODE\_2 [2:0])**

Pin No.	JEDEC	Mode0			Mode1	Mode2				Mode3				Mode4				
		Pin related to CAP0/1	Pin related to PWM	Pin related to I2S2	Pin related to CAPI (NRGB666)	Pin related to GPIO	Pin related to CAN	Pin related to I2S1/2	Pin related to MediaLB	Pin related to GPIO	Pin related to CAN	Pin related to I2S1	Pin related to MediaLB	Pin related to SPI	Pin related to GPIO	Pin related to CAN	Pin related to I2S1/2	Pin related to MediaLB
208	V3	VIN1[7]	-	-	R11[7]	GPIO_PD[5]	-	-	-	GPIO_PD[5]	-	-	-	-	GPIO_PD[5]	-	-	-
19	W1	VIN1[6]	-	-	R11[6]	GPIO_PD[4]	-	-	-	GPIO_PD[4]	-	-	-	-	GPIO_PD[4]	-	-	-
118	W2	VIN1[5]	-	-	R11[5]	-	CAN_TX0	-	-	-	CAN_TX0	-	-	-	-	CAN_TX0	-	-
209	W3	VIN1[4]	-	-	R11[4]	-	CAN_RX0	-	-	-	CAN_RX0	-	-	-	-	CAN_RX0	-	-
292	W4	VIN1[3]	-	-	R11[3]	-	CAN_TX1	-	-	-	CAN_TX1	-	-	-	-	CAN_TX1	-	-
119	Y2	VIN1[2]	-	-	R11[2]	-	CAN_RX1	-	-	-	CAN_RX1	-	-	-	-	CAN_RX1	-	-
210	Y3	VIN1[1]	-	-	G11[7]	-	-	I2S_SCK1	-	-	-	-	-	-	-	-	I2S_SCK1	-
293	Y4	VIN1[0]	-	-	G11[6]	-	-	I2S_WS1	-	-	-	-	-	-	-	-	I2S_WS1	-
211	AA3	VINVSYNCl	-	-	VINVSYNCl	-	-	I2S_ECLK1	-	-	-	-	-	-	-	-	I2S_ECLK1	-
294	AA4	VINHSYNCl	-	-	VINHSYNCl	-	-	I2S_SD11	-	-	-	-	-	-	-	-	I2S_SD11	-
22	AB1	VINFID1	-	-	VINFID1	-	-	I2S_SDO1	-	-	-	-	-	-	-	-	I2S_SDO1	-
202	M3	VINVSYNCO	-	-	G11[5]	-	-	-	MLB_DATA	-	-	-	MLB_DATA	-	-	-	-	MLB_DATA
203	N3	VINHSYNCO	-	-	G11[4]	-	-	-	MLB_SIG	-	-	-	MLB_SIG	-	-	-	-	MLB_SIG
112	N2	VINFID0	-	-	G11[3]	-	-	-	MLB_CLK	-	-	-	MLB_CLK	-	-	-	-	MLB_CLK
123	AD2	-	PWM_00	-	G11[2]	GPIO_PD[3]	-	-	-	GPIO_PD[3]	-	-	-	-	GPIO_PD[3]	-	-	-
122	AC2	-	PWM_01	-	B11[7]	GPIO_PD[2]	-	-	-	GPIO_PD[2]	-	-	-	-	GPIO_PD[2]	-	-	-
121	AB2	-	-	I2S_SDO2	B11[6]	-	-	I2S_SDO2	-	-	-	-	-	-	SPI_DO	GPIO_PD[1]	-	-
24	AD1	-	-	I2S_ECLK2	B11[5]	-	-	I2S_ECLK2	-	-	-	-	-	Reserved (Input/Output)	GPIO_PD[0]	-	-	-
23	AC1	-	-	I2S_SCK2	B11[4]	-	-	I2S_SCK2	-	-	-	-	-	SPI_SCK	-	-	I2S_SCK2	-
295	AB4	-	-	I2S_WS2	B11[3]	-	-	I2S_WS2	-	-	-	-	-	SPI_SS	-	-	I2S_WS2	-
212	AB3	-	-	I2S_SDI2	B11[2]	-	-	I2S_SDI2	-	-	-	-	-	SPI_DI	-	-	I2S_SDI2	-

**Pin multiplex group #2 mode setting**

This mode is set with MPX\_MODE\_2 bit (bit 2-0) in the multiplex mode setting register (CMUX\_MD.)

MPX_MODE_2 (bit 2-0) of the CMUX_MD register	Pin multiplex group #2 mode
000	Mode 0
001	Mode 1
010	Mode 2
011	Mode 3
100	Mode 4
101 – 0110	Reserved
111	(Initial value)

### Pin multiplex group #3 (setting pin: USB\_MODE)

Pin No.	JEDEC	Mode 0	Mode 1
		Pin related to USB 2.0 host	Pin related to USB 2.0 function
114	R2	USB_FSDP	USB_FSDP
115	T2	USB_FSDM	USB_FSDM
15	R1	USB_HSDP	USB_HSDP
16	T1	USB_HSDM	USB_HSDM
18	V1	USB_CRYCK48	USB_CRYCK48
230	AD19	USB_P RTPWR	USB_P RTPWR

### Pin multiplex group #3 mode setting

This mode is set with external pin, USB\_MODE.

USB_MODE pin	Pin multiplex group #3 mode
"L"	Mode 0
"H"	Mode 1

**Pin multiplex group #4 (setting register: PIN\_MPX\_Select.MPX\_MODE\_4 [1:0])**

Pin No.	JEDEC	Mode 0		Mode 1			Unused pin (input/output)
		Pin related to IDE	Pin related to I2S1	Pin related to CAN	Pin related to GPIO	Pin related to PWM	
29	AF4	IDE_XDRESET	-	-	-	-	Reserved (output)
28	AF3	IDE_XIOCS16	I2S_SDI1	-	-	-	-
125	AE3	IDE_XDASP	I2S_WS1	-	-	-	-
215	AD4	IDE_DDMARQ	I2S_ECLK1	-	-	-	-
296	AC4	IDE_DINTRQ	I2S_SDO1	-	-	-	-
214	AD3	IDE_XCBLID	I2S_SCK1	-	-	-	-
297	AC5	IDE_DD[15]	-	CAN_TX0	-	-	-
216	AD5	IDE_DD[14]	-	CAN_RX0	-	-	-
127	AE5	IDE_DD[13]	-	CAN_TX1	-	-	-
30	AF5	IDE_DD[12]	-	CAN_RX1	-	-	-
298	AC6	IDE_DD[11]	-	-	GPIO_PD[23]	-	-
217	AD6	IDE_DD[10]	-	-	GPIO_PD[22]	-	-
128	AE6	IDE_DD[9]	-	-	GPIO_PD[21]	-	-
31	AF6	IDE_DD[8]	-	-	GPIO_PD[20]	-	-
299	AC7	IDE_DD[7]	-	-	GPIO_PD[19]	-	-
218	AD7	IDE_DD[6]	-	-	GPIO_PD[18]	-	-
129	AE7	IDE_DD[5]	-	-	GPIO_PD[17]	-	-
32	AF7	IDE_DD[4]	-	-	GPIO_PD[16]	-	-
300	AC8	IDE_DD[3]	-	-	GPIO_PD[15]	-	-
219	AD8	IDE_DD[2]	-	-	GPIO_PD[14]	-	-
130	AE8	IDE_DD[1]	-	-	GPIO_PD[13]	-	-
33	AF8	IDE_DD[0]	-	-	-	-	Reserved (input/output)
213	AC3	IDE_DIORDY	-	-	-	-	Reserved (input)
301	AC9	IDE_DA[2]	-	-	-	-	Reserved (output)
220	AD9	IDE_DA[1]	-	-	-	PWM_O1	-
131	AE9	IDE_DA[0]	-	-	-	PWM_O0	-
35	AF10	IDE_XDCS[1]	-	-	-	-	Reserved (output)
132	AE10	IDE_XDCS[0]	-	-	-	-	Reserved (output)
221	AD10	IDE_XDIOR	-	-	-	-	Reserved (output)
302	AC10	IDE_XDIOW	-	-	-	-	Reserved (output)
34	AF9	IDE_CSEL	-	-	-	-	Reserved (output)
126	AE4	IDE_XDDMACK	-	-	-	-	Reserved (output)

**Pin multiplex group #4 mode setting**

This mode is set with MPX\_MODE\_4 bit (bit 5-4) in the multiplex mode setting register (CMUX\_MD.)

MPX_MODE_4 (Bit 5-4) of the CMUX_MD register	Pin multiplex group #4 mode
00	Mode 0
01	Mode 1
10	Reserved
11	(Initial value)

**Pin multiplex group #5 (setting pin: MPX\_MODE\_5 [1:0])**

Pin No.	JEDEC	Mode 0	Mode 1	Mode 2	
		Pin related to ETM	Pin related to UART3/4/5	Pin related to UART3/4	Pin related to PWM
270	C10	TRACECLK	UART_SIN3	UART_SIN3	-
185	B10	TRACECTL	UART_SOUT3	UART_SOUT3	-
92	A10	TRACEDATA[3]	UART_SIN4	UART_SIN4	-
346	D11	TRACEDATA[2]	UART_SOUT4	UART_SOUT4	-
269	C11	TRACEDATA[1]	UART_SIN5	-	PWM_O1
184	B11	TRACEDATA[0]	UART_SOUT5	-	PWM_O0

**Pin multiplex group #5 mode setting**

This mode is set with external pin, MPX\_MODE\_5[1:0].

MPX_MODE_5[1] pin	MPX_MODE_5[0] pin	Pin multiplex group #5 mode
"L"	"L"	Mode 0
"L"	"H"	Mode 1
"H"	"L"	Mode 2
"H"	"H"	Mode 0

## 7.2. Pin Function

### Format

Pin function list is shown in the following format.

Pin name	I/O	Polarity	Analog /Digital	Type	Status of pin after reset	Description
----------	-----	----------	-----------------	------	---------------------------	-------------

### Meaning of item and sign

#### Pin name

Name of external pin.

#### I/O

Input/Output signal's distinction based on this LSI.

- I: Pin that can be used as input
- O: Pin that can be used as output
- IO: Pin that can be used as input and output (interactive pin)

#### Polarity

Active polarity of external pin's input/output signals

- P: "H" active pin (positive logic)
- N: "L" active pin (negative logic)
- PN: "H" and "L" active pins

#### Analog/Digital

Signal type of external pin

- A: Analog signal
- D: Digital signal

#### Type

Input/Output circuit type of external pin.

- CLK:
- POD: Pseudo Open Drain
- PU: Pull Up
- PD: Pull Down
- ST: Schmitt Type
- Tri: Tri-state

#### Pin status after reset

Pin status after external pin reset

- H: "H" level
- L: "L" level
- HiZ: High impedance
- X: "H" level or "L" level
- A: Clock output

#### Description

Outline of external pin function

### 7.2.1. External bus interface related pin

Pin name	I/O	Polarity	Analog /Digital	Type	Status of pin after reset	Description
MEM_XCS[4]	O	N	D	-	H	Chip select 4
MEM_XCS[2]	O	N	D	-	H	Chip select 2
MEM_XCS[0]	O	N	D	-	H	Chip select 0
MEM_XRD	O	N	D	-	H	Read strobe
MEM_XWR[3:2]	O	N	D	-	H	Write strobe MEM_XWR[3] -> MEM_ED[31:24], MEM_XWR[2] -> MEM_ED[23:16] (optional pin)
MEM_XWR[1:0]	O	N	D	-	H	Write strobe MEM_XWR[1] -> MEM_ED[15:8], MEM_XWR[0] -> MEM_ED[7:0]
MEM_RDY	I	P	D	-	-	Ready input for slow device
MEM_EA[24:1]	O	-	D	-	L	Address bus
MEM_ED[31:16]	IO	-	D	-	HiZ	Bi-directional data bus (optional pin)
MEM_ED[15:0]	IO	-	D	-	HiZ	Bi-directional data Bus
DREQ[7:6]	I	-	D	-	-	External DMA request
XDACK[7:6]	O	P	D	-	L	External DMA acknowledge

### 7.2.2. IDE66 related pin

Pin name	I/O	Polarity	Analog /Digital	Type	Status of pin after reset	Description
IDE_XDRESET	O	N	D	-	H	IDE reset
IDE_DD[15:0]	IO	-	D	PD	L	IDE device data
IDE_XDCS[1:0]	O	N	D	-	H	IDE chip select
IDE_DA[2:0]	O	P	D	-	L	IDE device address
IDE_XDIOR	O	N	D	-	H	IDE device I/O read
IDE_XDIOW	O	N	D	-	H	IDE device I/O write
IDE_DIORDY	I	P	D	-	-	IDE I/O channel ready
IDE_DDMARQ	I	P	D	-	-	IDE device DMA request
IDE_XDDMACK	O	N	D	-	H	IDE device DMA acknowledge
IDE_CSEL	O	P	D	-	L	IDE cable select
IDE_XIOCS16	I	N	D	-	-	IDE 16 bit I/O
IDE_XDASP	I	N	D	PD	-	IDE device active
IDE_DINTRQ	I	P	D	PD	-	IDE Interrupt
IDE_XCBLID	I	N	D	PD	-	IDE cable ID

### 7.2.3. SD Memory controller related pin

Pin name	I/O	Polarity	Analog /Digital	Type	Status of pin after reset	Description
SD_CLK	O	N	D	-	L	Media clock
SD_CMD	IO	-	D	-	HiZ	Media command
SD_DAT[3:0]	IO	-	D	-	HiZ	Media data
SD_WP	I	P	D	-	-	Media write protection
SD_XMCD	I	N	D	-	-	Media card detection

### 7.2.4. USB 2.0 Host/Function related pin

Pin name	I/O	Polarity	Analog /Digital	Type	Status of pin after reset	Description
USB_FSDP	IO	-	A	-	-	D+ for FS
USB_FSDM	IO	-	A	-	-	D- for FS
USB_HSDP	IO	-	A	-	-	D+ for HS
USB_HSDM	IO	-	A	-	-	D- for HS
USB_CRYCK48	I	-	D	CLK	-	Clock used for USB communication
USB_PRTPOWER	O	-	D	-	L	USB port power control
USB_EXT12K	O	-	A	-	-	External resistance pin This should be connected to USB_AVDB through 12kΩ resistance.
USB_AVSP	I	-	A	-	-	PLL ground
USB_AVSB	I	-	A	-	-	Reference voltage ground
USB_AVDP	I	-	A	-	-	PLL power supply
USB_AVDB	I	-	A	-	-	Reference voltage power supply
USB_AVSF1	I	-	A	-	-	Driver/Receiver ground 1
USB_AVDF1	I	-	A	-	-	Driver/Receiver power supply 1
USB_AVSF2	I	-	A	-	-	Driver/Receiver ground 2
USB_AVDF2	I	-	A	-	-	Driver/Receiver power supply 2

### 7.2.5. External interrupt controller related pin

Pin name	I/O	Polarity	Analog /Digital	Type	Status of pin after reset	Description
INT_A[3:0]	I	PN	D	-	-	Asynchronous external interrupt requests



### 7.2.6. UART related pin

Pin name	I/O	Polarity	Analog /Digital	Type	Status of pin after reset	Explanation
UART_SIN0	I	P	D	-	-	Input data signal
UART_SOUT0	O	P	D	-	H	Output data signal
UART_XCTS0	I	N	D	-	-	Clear to send
UART_XRTS0	O	N	D	-	H	Request to send
UART_SIN1	I	P	D	-	-	Input data signal
UART_SOUT1	O	P	D	-	H	Output data signal
UART_SIN2	I	P	D	-	-	Input data signal
UART_SOUT2	O	P	D	-	H	Output data signal
UART_SIN3	I	P	D	-	-	Input data signal (optional)
UART_SOUT3	O	P	D	-	H	Output data signal (optional)
UART_SIN4	I	P	D	-	-	Input data signal (optional)
UART_SOUT4	O	P	D	-	H	Output data signal (optional)
UART_SIN5	I	P	D	-	-	Input data signal (optional)
UART_SOUT5	O	P	D	-	H	Output data signal (optional)

### 7.2.7. CAN related pin

Pin name	I/O	Polarity	Analog /Digital	Type	Status of pin after reset	Explanation
CAN_TX0	O	-	D	PD	H	Transmission (optional)
CAN_RX0	I	-	D	PD	-	Reception (optional)
CAN_TX1	O	-	D	PD	H	Transmission (optional)
CAN_RX1	I	-	D	PD	-	Reception (optional)

### 7.2.8. I2S related pin

Pin name	I/O	Polarity	Analog /Digital	Type	Status of pin after reset	Explanation
I2S_ECLK0	I	-	D	-	-	External clock (optional)
I2S_SCK0	IO	-	D	-	HiZ	Clock (optional)
I2S_WS0	IO	PN	D	-	HiZ	Sync (optional)
I2S_SDI0	I	P	D	-	-	Input data signal (optional)
I2S_SDO0	O	P	D	-	Hiz	Output data signal (optional)
I2S_ECLK1	I	-	D	-	-	External clock (optional)
I2S_SCK1	IO	-	D	PD	L	Clock (optional)
I2S_WS1	IO	PN	D	PD	L	Sync(optional)
I2S_SDI1	I	P	D	-	-	Input data signal (optional)
I2S_SDO1	O	P	D	PD	L	Output data signal (optional)
I2S_ECLK2	I	-	D	PD	-	External clock (optional)
I2S_SCK2	IO	-	D	PD	L	Clock (optional)
I2S_WS2	IO	PN	D	PD	L	Sync (optional)
I2S_SDI2	I	P	D	-	-	Input data signal (optional)
I2S_SDO2	O	P	D	PD	L	Output data signal (optional)

### 7.2.9. I<sup>2</sup>C related pin

Pin name	I/O	Polarity	Analog /Digital	Type	Status of pin after reset	Explanation
I2C_SCL0	IO	-	D	POD	HiZ	I2C clock
I2C_SDA0	IO	-	D	POD	HiZ	I2C data
I2C_SCL1	IO	-	D	POD	HiZ	I2C clock
I2C_SDA1	IO	-	D	POD	HiZ	I2C data

### 7.2.10. SPI related pin

Pin name	I/O	Polarity	Analog /Digital	Type	Status of pin after reset	Explanation
SPI_DO	O	P	D	PD	L	Serial data output (optional)
SPI_DI	I	P	D	-	-	Serial data input (optional)
SPI_SCK	O	-	D	PD	L	Serial clock (optional)
SPI_SS	O	PN	D	PD	L	Slave select (optional)

### 7.2.11. PWM related pin

Pin name	I/O	Polarity	Analog /Digital	Type	Status of pin after reset	Explanation
PWM_O0	O	-	D	PD (*1)	L	PWM out 0 (optional)
PWM_O1	O	-	D	PD (*1)	L	PWM out 1 (optional)

\*1: Only PWM pin of the pin multiplex group #2 is with pull-down resistance.

### 7.2.12. A/D converter related pin

Pin name	I/O	Polarity	Analog /Digital	Type	Status of pin after reset	Explanation
AD_VIN0	I	-	A	-	-	A/D analog input
AD_VRH0	I	-	A	-	-	Reference voltage "H" input
AD_VRL0	I	-	A	-	-	Reference voltage "L" input
AD_AVD	I	-	A	-	-	Analog power supply
AD_VR0	O	-	A	-	-	Reference output
AD_VIN1	I	-	A	-	-	A/D analog input
AD_VRH1	I	-	A	-	-	Reference voltage "H" input
AD_VRL1	I	-	A	-	-	Reference voltage "L" input
AD_AVS	I	-	A	-	-	Analog ground
AD_VR1	O	-	A	-	-	Reference output

### 7.2.13. DDR2 related pin

Pin name	I/O	Polarity	Analog /Digital	Type	Status of pin after reset	Explanation
MA[13:0]	O	P	D	-	H	Address
MBA[1:0]	O	P	D	-	H	Bank address
MDQ[31:0]	IO	P	D	-	H	Data (*5)
MDM[3:0]	O	P	D	-	HiZ	Data mask (*6)
MDQSP[3:0]	IO	P	D	-	HiZ	Data strobe (*5)
MDQSN[3:0]	IO	N	D	-	HiZ	Data strobe (*5)
MCKP	O	P	D	CLK	L	Clock output
MCKN	O	N	D	CLK	H	Clock output
MCKE	O	P	D	-	L	Clock enable
MCS	O	N	D	-	L	Chip select
MRAS	O	N	D	-	H	Row address strobe
MCAS	O	N	D	-	H	Column address strobe
MWE	O	N	D	-	H	Write enable
DDRVDE	I	-	A	-	-	SSTL_18 1.8V power supply
VREF1	I	-	A	-	-	Reference voltage input (DDRVDE/2)
VREF0	I	-	A	-	-	Reference voltage input (DDRVDE/2)
OCD	O	-	A	-	-	Off chip driver reference voltage input (*1)
ODT	O	-	A	-	-	On-die termination reference voltage input (*2)
ODTCONT	O	P	D	-	L	On-die termination control (*3)
MCKE_START	I	P	D	-	-	Set a state of MCKE in reset 0: Low (*4) 1: High (reserved)
DDRTYPE	I	P	D	-	-	Pull-up pin to VDDE via high resistance

\*1: Pull up the pin to DDRVDE (1.8V power supply), via 200Ω resistance

\*2: PCB impedance Z = 100Ω or 50Ω: Pull up pin to DDRVDE (1.8V power supply), via a 180Ω resistance.  
PCB impedance Z = 150Ω or 75Ω: Pull up pin to DDRVDE (1.8V power supply), via a 240Ω resistance.

\*3: It connects it with the ODT pin of DDR2SDRAM

\*4: Pull down pin to VSS, via high resistance

\*5: This is process of unused pin at 16 bit mode. Pull down the pin to VSS via high resistance.

Unused pins at 16 bit mode are as follows:

"MDQ[31:16], MDQSP[3:2], MDQSN[3:2]"

\*6: This is process of MDM[3:2] at 16 bit mode. Be sure to open this pin.

## 7.2.14. DISPLAY related pin

Pin name	I/O	Polarity	Analog /Digital	Type	Status of pin after reset	Explanation
HSYNC0	IO	-	D	-	HiZ	Video output interface horizontal sync output Horizontal sync input in external sync mode
VSYNC0	IO	-	D	-	HiZ	Video output interface vertical sync output Vertical sync input in external sync mode
GV0	O	-	D	-	L	Video output interface graphics/video switch
DCLKIN0	I	-	D	CLK	-	Video output interface dot clock input
DCLKO0	O	-	D	CLK	X	Video output interface dot clock output
DE0	O	-	D	-	X	DE/CSYNC
DOUTr0[7:2]	O	-	D	-	X	Digital RGB output0 DataR[7:2]
DOUTr0[1:0]	O	-	D	-	X	Digital RGB output0 DataR[1:0] (optional)
DOuTG0[7:2]	O	-	D	-	X	Digital RGB output0 DataG[7:2]
DOuTG0[1:0]	O	-	D	-	X	Digital RGB output0 DataG[1:0] (optional)
DOuTB0[7:2]	O	-	D	-	X	Digital RGB output0 DataB[7:2]
DOuTB0[1:0]	O	-	D	-	X	Digital RGB output0 DataB[1:0] (optional)
HSYNC1	IO	-	D	-	HiZ	Video output interface horizontal sync output Horizontal sync input in external sync mode
VSYNC1	IO	-	D	-	HiZ	Video output interface vertical sync output Vertical sync input in external sync mode
GV1	O	-	D	-	L	Video output interface graphics/video switch
DCLKIN1	I	-	D	CLK	-	Video output interface dot clock input
DCLKO1	O	-	D	CLK	X	Video output interface dot clock output
DE1	O	-	D	-	X	DE/CSYNC
DOUTr1[7:2]	O	-	D	-	X	Digital RGB output1 DataR[7:2]
DOuTG1[7:2]	O	-	D	-	X	Digital RGB output1 DataG[7:2]
DOuTB1[7:2]	O	-	D	-	X	Digital RGB output1 DataB[7:2]

### Note:

When R:G:B = 5:5:5, lower 1 bit is set with the data contents of the upper 5 bits.

[Upper 5 bits]	[Lower 1 bit]
DOUTr0[7:3]=00000	-> DOUTr0[2]=0 (Low)
DOUTr0[7:3]=00001-11111	-> DOUTr0[2]=1 (High)
DOUTr1[7:3]=00000	-> DOUTr1[2]=0 (Low)
DOUTr1[7:3]=00001-11111	-> DOUTr1[2]=1 (High)

DOuTG0[7:2], DOuTG1[7:2], DOuTB0[7:2], and DOuTB1[7:2] have also the same spec.

## 7.2.15. Video capture related pin

Pin name	I/O	Polarity	Analog /Digital	Type	Status of pin after reset	Description
VIN0[7:0]	I	-	D	-	-	Video capture Data[7:0]
VINVSYNCO	I	-	D	PD	-	Video capture vertical sync input
VINHSYNCO	I	-	D	PD	-	Video capture horizontal sync input
VINFID0	I	-	D	-	-	Video input field identification signal 0 in odd field
CCLK0	I	-	D	CLK	-	Video capture input clock
VIN1[7:0]	I	-	D	PD	-	Video capture Data[7:0]
VINVSYNCO	I	-	D	-	-	Video capture vertical sync input
VINHSYNCO	I	-	D	-	-	Video capture horizontal sync input
VINFID1	I	-	D	PD	-	Video input field identification signal 0 in odd field
CCLK1	I	-	D	CLK	-	Video capture input clock
RI1[7:2]	I	-	D	PD	-	NRGB666 capture DataR[7:2] (optional)
GI1[7:2]	I	-	D	PD (*1)	-	NRGB666 capture DataG[7:2] (optional)
BI1[7:2]	I	-	D	PD (*2)	-	NRGB666 capture DataB[7:2] (optional)

\*1: GI1[3] is not applicable.

\*2: BI1[2] is not applicable.

## 7.2.16. System related pin

Pin name	I/O	Polarity	Analog /Digital	Type	Status of pin after reset	Description
CLK	I	-	D	CLK	-	Input clock
XRST	I	N	D	ST	-	System reset
CRIPM[3:0]	I	-	D	-	-	PLLMODE setting
VINITHI	I	-	D	-	-	Boot high address
PLLBYPASS	I	-	D	-	-	PLL bypass mode setting
BIGEND	I	-	D	-	-	LSI endian setting Low: Little endian High: Big endian
PLLVSS	I	-	A	-	-	PLL ground
PLLTDRST	I	-	D	-	-	Test pin Pull up the pin to VDDE, via high resistance
PLLVDD	I	-	A	-	-	PLL power supply

## 7.2.17. JTAG related pin

Pin name	I/O	Polarity	Analog /Digital	Type	Status of pin after reset	Description
TCK	I	-	D	ST, PU	-	Test clock
XTRST	I	N	D	ST, PU	-	Test reset
TMS	I	N	D	PU	-	Test mode
TDI	I	-	D	PU	-	Test data input
TDO	O	-	D	Tri	HiZ	Test data output

### 7.2.18. ICE related pin

Pin name	I/O	Polarity	Analog /Digital	Type	Status of pin after reset	Description
RTCK	O	-	D	-	H	Return test clock
XSRST	IO	N	D	ST, PU	H	System reset

### 7.2.19. Multiplex setting related pin

Pin name	I/O	Polarity	Analog /Digital	Type	Status of pin after reset	Description
JTAGSEL	I	-	D	-	-	JTAG selection 1: DFT, 0: Normal Pull it down to VSS, via high resistance
MPX_MODE_5[1:0]	I	-	D	-	-	External pin multiplex mode 5
MPX_MODE_1[1:0]	I	-	D	-	-	External pin multiplex mode 1
USB_MODE	I	-	D	-	-	USB selection 0: Host, 1: Function
TESTMODE[2:0]	I	-	D	-	-	Test mode selection pin Pull it down to VSS, via high resistance
VPD	I	-	D	-	-	Test mode selection pin Pull it down to VSS, via high resistance

### 7.2.20. ETM related pin

Pin name	I/O	Polarity	Analog /Digital	Type	Status of pin after reset	Description
TRACECLK	O	-	D	-	L	Exported clock for TRACEDATA[3:0] and TRACECTL They are valid on both edges of TRACECLK for max. integrity.
TRACECTL	O	-	D	-	H	Trace control signal used by the trace tool such as RealView supplied by ARM Limited.
TRACEDATA[3:0]	O	-	D	-	LHHH	Trace data used by the trace tool such as RealView supplied by ARM Limited.

### 7.2.21. Power supply related pin

Pin name	I/O	Polarity	Analog /Digital	Type	Status of pin after reset	Description
VSS	I	-	D	-	-	Ground
VDDE	I	-	D	-	-	External pin power supply
VDDI	I	-	D	-	-	Internal power supply

### 7.2.22. MediaLB related pin

Pin name	I/O	Polarity	Analog /Digital	Type	Status of pin after reset	Description
MLB_DATA	IO	P	D	PD	HiZ	Data (optional) (*1)
MLB_SIG	IO	P	D	PD	HiZ	Control (optional) (*1)
MLB_CLK	I	-	D	CLK	-	Clock (optional) (*1)

\*1: MediaLB pin of this LSI uses 3.3[V] I/O; therefore, when connecting bus's voltage is not 3.3[V], level conversion at external side is needed.

### 7.2.23. GPIO related pin

Pin name	I/O	Polarity	Analog /Digital	Type	Status of pin after reset	Description
GPIO_PD[23:0]	IO	-	D	PD (*1)	HiZ	General purpose I/O port (optional)

\*1: GPIO\_PD[12:6] is not applicable.

## 7.2.24. Unused pin

Proceed following processes for unused pin.

Pin No.	JEDEC	Pin name	Process
3	C1	DOUTB1[2], MEM_XWR[2], DOUTB0[0]	Pull up to VDDE or pull down to VSS through high resistance.
4	D1	DOUTB1[6], MEM_ED[18], DOUTR0[0]	
5	E1	DOUTG1[4], MEM_ED[22], GPIO_PD[8]	
6	F1	DOUTR1[2], MEM_ED[26], GPIO_PD[12]	
7	G1	DCLKIN1	
9	J1	DCLKO1	Keep the pin open.
10	K1	VIN0[5]	Pull up to VDDE or pull down to VSS through high resistance.
11	L1	VIN0[1]	
12	M1	CCLK0	
14	P1	USB_AVSP	Connect to VSS.
15	R1	USB_HSDP	Pull down to VSS through 10kΩ resistance.
16	T1	USB_HSDM	
17	U1	USB_AVSF2	Connect to VSS.
18	V1	USB_CRYCK48	Pull up to VDDE or pull down to VSS through high resistance.
19	W1	VIN1[6], RI1[6], GPIO_PD[4]	Keep the pin open.
21	AA1	CCLK1	Pull up to VDDE or pull down to VSS through high resistance.
22	AB1	VINFID1, I2S_SDO1	
23	AC1	I2S_SCK2, BI1[4], SPI_SCK	Keep the pin open.
24	AD1	I2S_ECLK2, BI1[5], Reserved (input/output), GPIO_PD[0]	
28	AF3	IDE_XIOCS16, I2S_SDI1	
29	AF4	IDE_XDRESET, Reserved (output)	Keep the pin open.
30	AF5	IDE_DD[12], CAN_RX1	
31	AF6	IDE_DD[8], GPIO_PD[20]	
32	AF7	IDE_DD[4], GPIO_PD[16]	
33	AF8	IDE_DD[0], Reserved (input/output)	
34	AF9	IDE_CSEL, Reserved (output)	
35	AF10	IDE_XDCS[1], Reserved (output)	
36	AF11	MPX_MODE_5[1]	
38	AF13	AD_AVD	Connect to VSS.
39	AF14	AD_AVS	
40	AF15	UART_SOUT0	Keep the pin open.
41	AF16	UART_SIN0	Pull up to VDDE or pull down to VSS through high resistance.
42	AF17	UART_SIN1	
43	AF18	SD_DAT[0]	
44	AF19	SD_WP	



Pin No.	JEDEC	Pin name	Process
45	AF20	I2C_SCL1	Pull up to VDDE or pull down to VSS through high resistance.
46	AF21	I2C_SDA1	
47	AF22	INT_A[0]	
48	AF23	MA[8]	Keep the pin open.
49	AF24	MA[12]	
52	AE26	MA[7]	
53	AD26	MA[3]	
54	AC26	MA[1]	
55	AB26	MBA[1]	
57	Y26	MDQSN[0]	Pull down to VSS through high resistance.
58	W26	MDQSP[0]	
60	U26	MDQSN[1]	
61	T26	MDQSP[1]	
63	P26	MCKN	Keep the pin open.
64	N26	MCKP	
66	L26	MDQSN[2]	Pull down to VSS through high resistance.
67	K26	MDQSP[2]	
69	H26	MDQSN[3]	
70	G26	MDQSP[3]	
72	E26	MEM_ED[3]	Pull up to VDDE or pull down to VSS through high resistance.
73	D26	MEM_ED[7]	
74	C26	MEM_ED[11]	
78	A24	MEM_EA[1]	
79	A23	MEM_EA[4]	
80	A22	MEM_EA[8]	
81	A21	MEM_EA[12]	
82	A20	MEM_EA[16]	
83	A19	MEM_EA[20]	
85	A17	MEM_XRD	
88	A14	TDO	Keep the pin open.
92	A10	TRACEDATA[3], UART_SIN4	Pull up to VDDE or pull down to VSS through high resistance.
94	A8	DOUTB0[4]	Keep the pin open.
95	A7	DOUTG0[2]	
96	A6	DOUTG0[6]	
97	A5	DCLKIN0	Pull up to VDDE or pull down to VSS through high resistance.
99	A3	DCLKO0	Keep the pin open.
101	B2	DE0	
102	C2	GV0	
103	D2	DOUTB1[5], MEM_ED[17], DOUTG0[1]	Pull up to VDDE or pull down to VSS through high resistance.
104	E2	DOUTG1[3], MEM_ED[21], GPIO_PD[7]	
105	F2	DOUTG1[7], MEM_ED[25], GPIO_PD[11]	

Pin No.	JEDEC	Pin name	Process
106	G2	DOUTR1[5], MEM_ED[29], I2S_WS0	Pull up to VDDE or pull down to VSS through high resistance.
108	J2	GV1, DREQ[7]	
109	K2	VIN0[6]	
110	L2	VIN0[2]	
112	N2	VINFID0, GI1[3], MLB_CLK	
113	P2	USB_AVDP	Connect to VDDI.
114	R2	USB_FSDP	Pull down to VSS through 10kΩ resistance.
115	T2	USB_FSDM	
116	U2	USB_AVSF2	Connect to VSS.
117	V2	USB_MODE	Pull up to VDDE or pull down to VSS through high resistance.
118	W2	VIN1[5], RI1[5], CAN_TX0	Keep the pin open.
119	Y2	VIN1[2], RI1[2], CAN_RX1	
121	AB2	I2S_SDO2, BI1[6], SPI_DO, GPIO_PD[1]	
122	AC2	PWM_O1, BI1[7], GPIO_PD[2]	
123	AD2	PWM_O0, GI1[2], GPIO_PD[3]	
125	AE3	IDE_XDASP, I2S_WS1	
126	AE4	IDE_XDDMACK, Reserved (output)	
127	AE5	IDE_DD[13], CAN_TX1	
128	AE6	IDE_DD[9], GPIO_PD[21]	
129	AE7	IDE_DD[5], GPIO_PD[17]	
130	AE8	IDE_DD[1], GPIO_PD[13]	
131	AE9	IDE_DA[0], PWM_O0	
132	AE10	IDE_XDCS[0], Reserved (output)	
133	AE11	MPX_MODE_5[0]	
135	AE13	AD_VRH0	Connect to VSS.
136	AE14	AD_VRH1	
137	AE15	UART_XRTS0	Keep the pin open.
138	AE16	UART_XCTS0	Pull up to VDDE or pull down to VSS through high resistance.
139	AE17	UART_SOUT1	
140	AE18	SD_DAT[1]	Pull up to VDDE or pull down to VSS through high resistance.
141	AE19	SD_XMCD	
142	AE20	I2C_SCL0	
143	AE21	INT_A[3]	
144	AE22	MCKE_START	
145	AE23	MA[13]	Keep the pin open.
146	AE24	MA[4]	
147	AE25	MA[11]	
148	AD25	MA[5]	
149	AC25	MA[10]	
150	AB25	MBA[0]	

Pin No.	JEDEC	Pin name	Process
151	AA25	MCKE	Keep the pin open.
152	Y25	MDQ[2]	Pull down to VSS through high resistance.
153	W25	MDQ[0]	
154	V25	VREF0	Connect to DDRVDE/2[V]Reference voltage.
155	U25	MDQ[13]	Pull down to VSS through high resistance.
156	T25	MDQ[8]	
157	R25	MDQ[15]	
160	M25	MDQ[21]	
161	L25	MDQ[16]	
162	K25	VREF1	Connect to DDRVDE/2[V]Reference voltage.
163	J25	MDQ[29]	Pull down to VSS through high resistance.
164	H25	MDQ[24]	
165	G25	MDQ[31]	
166	F25	MEM_ED[0]	Pull up to VDDE or pull down to VSS through high resistance.
167	E25	MEM_ED[4]	
168	D25	MEM_ED[8]	
169	C25	MEM_ED[12]	
170	B25	MEM_ED[14]	
171	B24	MEM_ED[15]	
172	B23	MEM_EA[3]	
173	B22	MEM_EA[7]	
174	B21	MEM_EA[11]	
175	B20	MEM_EA[15]	
176	B19	MEM_EA[19]	
177	B18	MEM_EA[23]	
178	B17	MEM_XWR[1]	
179	B16	MEM_XCS[4]	
183	B12	TMS	
184	B11	TRACEDATA[0], UART_SOUT5, PWM_O0	
185	B10	TRACECTL, UART_SOUT3	Keep the pin open.
187	B8	DOUTB0[5]	
188	B7	DOUTG0[3]	
189	B6	DOUTG0[7]	
190	B5	DOUTR0[4]	
192	B3	HSYNC0	Pull up to VDDE or pull down to VSS through high resistance.
193	C3	VSYNC0	
194	D3	DOUTB1[4], MEM_ED[16], DOUTG0[0]	
195	E3	DOUTG1[2], MEM_ED[20], GPIO_PD[6]	
196	F3	DOUTG1[6], MEM_ED[24], GPIO_PD[10]	
197	G3	DOUTR1[4], MEM_ED[28], I2S_SDI0	
198	H3	DOUTR1[7], MEM_ED[31], I2S_ECLK0	
199	J3	VSYNC1, XDACK[6]	

Pin No.	JEDEC	Pin name	Process
200	K3	VIN0[7]	Pull up to VDDE or pull down to VSS through high resistance.
201	L3	VIN0[3]	
202	M3	VINVSYNC0, G11[5], MLB_DATA	Keep the pin open.
203	N3	VINHsync0, G11[4], MLB_SIG	
204	P3	USB_AVSF1	Connect to VSS.
205	R3	USB_AVDF1	Connect to VDDE.
206	T3	USB_AVSF2	Connect to VSS.
207	U3	USB_AVDF2	Connect to VDDI.
208	V3	VIN1[7], R11[7], GPIO_PD[5]	Keep the pin open.
209	W3	VIN1[4], R11[4], CAN_RX0	
210	Y3	VIN1[1], G11[7], I2S_SCK1	
211	AA3	VINVSYNC1, I2S_ECLK1	Pull up to VDDE or pull down to VSS through high resistance.
212	AB3	I2S_SDI2, B11[2], SPI_DI	
213	AC3	IDE_DIORDY, Reserved (input)	
214	AD3	IDE_XCBLID, I2S_SCK1	Keep the pin open.
215	AD4	IDE_DDMARQ, I2S_ECLK1	Pull up to VDDE or pull down to VSS through high resistance.
216	AD5	IDE_DD[14], CAN_RX0	Keep the pin open.
217	AD6	IDE_DD[10], GPIO_PD[22]	
218	AD7	IDE_DD[6], GPIO_PD[18]	
219	AD8	IDE_DD[2], GPIO_PD[14]	
220	AD9	IDE_DA[1], PWM_O1	
221	AD10	IDE_XDIOR, Reserved (output)	
222	AD11	MPX_MODE_1[1]	Pull up to VDDE or pull down to VSS through high resistance.
224	AD13	AD_VIN0	Connect to VSS.
225	AD14	AD_VIN1	
227	AD16	UART_SOUT2	Keep the pin open.
228	AD17	SD_CMD	Pull up to VDDE or pull down to VSS through high resistance.
229	AD18	SD_DAT[2]	
230	AD19	USB_PRTPOWER	Keep the pin open.
231	AD20	I2C_SDA0	Pull up to VDDE or pull down to VSS through high resistance.
232	AD21	INT_A[1]	
234	AD23	MA[9]	Keep the pin open.
235	AD24	MA[6]	
236	AC24	MA[2]	
237	AB24	MWE	
238	AA24	MRAS	
239	Y24	MDQ[5]	Pull down to VSS through high resistance.
240	W24	MDQ[1]	
241	V24	MDQ[7]	
242	U24	MDQ[10]	
243	T24	MDQ[9]	

Pin No.	JEDEC	Pin name	Process
244	R24	MDM[1]	Pull down to VSS through high resistance.
247	M24	MDQ[18]	
248	L24	MDQ[17]	
249	K24	MDQ[23]	
250	J24	MDQ[26]	
251	H24	MDQ[28]	
252	G24	MDM[3]	
253	F24	MEM_ED[1]	Pull up to VDDE or pull down to VSS through high resistance.
254	E24	MEM_ED[5]	
255	D24	MEM_ED[9]	
256	C24	MEM_ED[13]	
257	C23	MEM_EA[2]	
258	C22	MEM_EA[6]	
259	C21	MEM_EA[10]	
260	C20	MEM_EA[14]	
261	C19	MEM_EA[18]	
262	C18	MEM_EA[22]	
263	C17	MEM_XWR[0]	
264	C16	MEM_XCS[2]	
267	C13	TCK	
269	C11	TRACEDATA[1], UART_SIN5, PWM_O1	
270	C10	TRACECLK, UART_SIN3	
271	C9	DOUTB0[2]	Keep the pin open.
272	C8	DOUTB0[6]	
273	C7	DOUTG0[4]	
274	C6	DOUTR0[2]	
275	C5	DOUTR0[5]	
276	C4	DOUTR0[7]	
277	D4	DOUTB1[3], MEM_XWR[3], DOUTB0[1]	Pull up to VDDE or pull down to VSS through high resistance.
278	E4	DOUTB1[7], MEM_ED[19], DOUTR0[1]	
279	F4	DOUTG1[5], MEM_ED[23], GPIO_PD[9]	
280	G4	DOUTR1[3], MEM_ED[27], I2S_SDO0	
281	H4	DOUTR1[6], MEM_ED[30], I2S_SCK0	
282	J4	HSYNC1, DREQ[6]	
283	K4	DE1, XDACK[7]	Keep the pin open.
284	L4	VIN0[4]	Pull up to VDDE or pull down to VSS through high resistance.
285	M4	VIN0[0]	
287	P4	USB_AVSB	Connect to VSS.
288	R4	USB_AVSF2	
289	T4	USB_AVSF2	
292	W4	VIN1[3], RI1[3], CAN_TX1	Keep the pin open.

Pin No.	JEDEC	Pin name	Process	
293	Y4	VIN1[0], GI1[6], I2S_WS1	Keep the pin open.	
294	AA4	VINHSYNC1, I2S_SDI1	Pull up to VDDE or pull down to VSS through high resistance.	
295	AB4	I2S_WS2, BI1[3], SPI_SS	Keep the pin open.	
296	AC4	IDE_DINTRQ, I2S_SDO1		
297	AC5	IDE_DD[15], CAN_TX0		
298	AC6	IDE_DD[11], GPIO_PD[23]		
299	AC7	IDE_DD[7], GPIO_PD[19]		
300	AC8	IDE_DD[3], GPIO_PD[15]		
301	AC9	IDE_DA[2], Reserved (output)		
302	AC10	IDE_XDIOW, Reserved (output)		
303	AC11	MPX_MODE_1[0]		Pull up to VDDE or pull down to VSS through high resistance.
305	AC13	AD_VR0	Connect to VSS.	
306	AC14	AD_VR1		
308	AC16	UART_SIN2	Pull up to VDDE or pull down to VSS through high resistance.	
309	AC17	SD_CLK	Keep the pin open.	
310	AC18	SD_DAT[3]	Pull up to VDDE or pull down to VSS through high resistance.	
312	AC20	INT_A[2]		
313	AC21	DDRTYPE	Pull up to VDDE through high resistance.	
314	AC22	ODTCONT	Keep the pin open.	
315	AC23	MA[0]		
316	AB23	MCS		
317	AA23	MCAS		
318	Y23	MDQ[3]		Pull down to VSS through high resistance.
319	W23	MDQ[4]		
320	V23	MDM[0]		
321	U23	MDQ[11]		
322	T23	MDQ[12]		
323	R23	MDQ[14]		
324	P23	OCD	Keep the pin open.	
325	N23	ODT		
326	M23	MDQ[19]	Pull down to VSS through high resistance.	
327	L23	MDQ[20]		
328	K23	MDM[2]		
329	J23	MDQ[27]		
330	H23	MDQ[25]		
331	G23	MDQ[30]		
332	F23	MEM_ED[2]		Pull up to VDDE or pull down to VSS through high resistance.
333	E23	MEM_ED[6]		
334	D23	MEM_ED[10]		
335	D22	MEM_EA[5]		

Pin No.	JEDEC	Pin name	Process
336	D21	MEM_EA[9]	Pull up to VDDE or pull down to VSS through high reistance.
337	D20	MEM_EA[13]	
338	D19	MEM_EA[17]	
339	D18	MEM_EA[21]	
340	D17	MEM_EA[24]	
341	D16	MEM_XCS[0]	
342	D15	MEM_RDY	
344	D13	TDI	
346	D11	TRACEDATA[2], UART_SOUT4	
347	D10	RTCK	Keep the pin open.
348	D9	DOUTB0[3]	
349	D8	DOUTB0[7]	
350	D7	DOUTG0[5]	
351	D6	DOUTR0[3]	
352	D5	DOUTR0[6]	
362	P5	USB_AVDB	Connect to VDDE.
363	R5	USB_EXT12K	Pull down to VSS through 10kΩ resistance.
364	T5	USB_AVSF2	Connect to VSS.
378	AB13	AD_VRL0	
379	AB14	AD_VRL1	
391	V22	MDQ[6]	Pull down to VSS through high resistance.
398	L22	MDQ[22]	

## 7.2.25. Unused pin with pin multiplex function in the duplex case

PWM, I2S1, and CAN pins may be duplicated and allocated to external pin depending on pin multiplex function's group combination. In this case, follow the procedure below.

Pin No.	JEDEC	Pin multiplex group: pin name	Process	
122	AC2	Pin multiplex group #2:PWM_O1	Keep the pin open.	
123	AD2	Pin multiplex group #2:PWM_O0		
220	AD9	Pin multiplex group #4:PWM_O1		
131	AE9	Pin multiplex group #4:PWM_O0		
269	C11	Pin multiplex group #5:PWM_O1	Pull down to VSS through high resistance.	
184	B11	Pin multiplex group #5:PWM_O0		
118	W2	Pin multiplex group #2:CAN_TX0	Keep the pin open.	
292	W4	Pin multiplex group #2:CAN_TX1		
209	W3	Pin multiplex group #2:CAN_RX0		
119	Y2	Pin multiplex group #2:CAN_RX1		
297	AC5	Pin multiplex group #4:CAN_TX0		
127	AE5	Pin multiplex group #4:CAN_TX1		
216	AD5	Pin multiplex group #4:CAN_RX0		
30	AF5	Pin multiplex group #4:CAN_RX1		
210	Y3	Pin multiplex group #2:I2S_SCK1		
293	Y4	Pin multiplex group #2:I2S_WS1		
211	AA3	Pin multiplex group #2:I2S_ECLK1		Pull down to VSS through high resistance.
294	AA4	Pin multiplex group #2:I2S_SDI1		
22	AB1	Pin multiplex group #2:I2S_SDO1		Keep the pin open.
28	AF3	Pin multiplex group #4:I2S_SDI1	Pull down to VSS through high resistance.	
125	AE3	Pin multiplex group #4:I2S_WS1	Keep the pin open.	
215	AD4	Pin multiplex group #4:I2S_ECLK1	Pull down to VSS through high resistance.	
214	AD3	Pin multiplex group #4:I2S_SCK1	Keep the pin open.	
296	AC4	Pin multiplex group #4:I2S_SDO1		



## 8. Electrical Characteristics

### 8.1. Maximum Ratings

Table 8-1, Table 8-2, and Table 8-3 show the maximum ratings.

**Table 8-1 Maximum Ratings**

Parameter	Symbol	Rating	Unit
Supply voltage	VDDI, PLLVDD VDDE DDRVDE	-0.5 to 1.8 (*1) -0.5 to 4.0 (*2) -0.5 to 2.5 (*3)	V
Input voltage	$V_I$	-0.5 to VDDI + 0.5 (< 1.8V) -0.5 to VDDE + 0.5 (< 4.0V) -0.5 to DDRVDE + 0.5 (< 2.5V)	V
Output voltage	$V_O$	-0.5 to VDDI + 0.5 (< 1.8V) -0.5 to VDDE + 0.5 (< 4.0V) -0.5 to DDRVDE + 0.5 (< 2.5V)	V
Storage temperature	$T_{ST}$	-55 to 125	°C
Junction temperature	$T_J$	-40 to 125	°C
Power consumption	$P_D$	1.5	W
Supply current	$I_D$	1.2V: 690.1 (*4) 1.8V: 508 (*4) 3.3V: 125.3 (*4)	mA

\*1: Power supply for internal part or PLL

\*2: Power supply for I/O part

\*3: Power supply for SSTL\_18 I/O part

\*4: Current specification necessary for each voltage power supply

**Note:**

- Applying stress exceeding the maximum ratings (voltage, current, temperature, etc.) may cause damage to semiconductor devices. Never exceed the ratings above.
- Since thermal destruction of elements might occur, do not connect IC output or I/O pin directly, or connect them to  $V_{DD}$  or  $V_{SS}$  directly, except the pin designed output timing to prevent such incident.
- Provide ESD protection, such as grounding when handling the product; otherwise externally-charged electric charge flows into the IC and discharges, which may cause circuit destruction.
- Applying voltage higher than  $V_{DD}$  or lower than  $V_{SS}$  to I/O pins of CMOS IC, or applying voltage higher than the ratings between  $V_{DD}$  and  $V_{SS}$  may cause latch up. The latch up increases supply current, resulting in thermal destruction of elements. When handling the product, never exceed the maximum ratings.

**Table 8-2 ADC Maximum Ratings**

Parameter	Symbol	Rating	Unit
Supply voltage	AD_AVDD0	-0.5 to 4.0	V
Input voltage	AD_VRH0 AD_VRH1 AD_VRL0 AD_VRL1 AD_VIN0 AD_VIN1	-0.5 to VDDE + 0.5 (< 4.0V)	V
Output voltage	AD_VR0 AD_VR1	-0.5 to VDDE + 0.5 (< 4.0V)	V
Junction temperature	T <sub>J</sub>	-40 to 125	°C

The maximum ratings of USB PHY are shown in Table 8-3.

**Table 8-3 USB2.0 Maximum Ratings**

Parameter	Symbol	Rating	Unit
Supply voltage	USB_AVDF1 USB_AVDB	V <sub>SS</sub> --0.5 to 4.0	V
	USB_AVDF2 USB_AVDP	V <sub>SS</sub> --0.5 to 1.8	V
Junction temperature	T <sub>J</sub>	-40 to 125	°C
Supply current	USB_AVDF1 USB_AVDB	Total 37.5	mA
	USB_AVDF2	19.2	mA
	USB_AVDP	13.0	mA

The maximum ratings are the limits that must not be exceeded. As long as USB PHY is used within the range predetermined in the maximum ratings, it never suffers permanent damage. However, this does not assure normal logic operation.

## 8.2. Recommended Operating Conditions

**Table 8-4 3.3V Standard CMOS I/O Recommended Operating Conditions**

Parameter		Symbol	Rating			Unit
			Min.	Typ.	Max.	
Power supply voltage		VDDE VDDI, PLLVDD	3.0 1.1	3.3 1.2	3.6 1.3	V
Input voltage (High level)	3.3V CMOS	VIH	2.0	–	VDDE + 0.3	V
Input voltage (Low level)	3.3V CMOS	VIL	-0.3	–	0.8	V
Operating ambient temperature		T <sub>A</sub>	-40	–	85	°C
Junction temperature		T <sub>J</sub>	-40	–	125	°C

**Table 8-5 SSTL\_18 Recommended Operating Conditions**

Parameter	Symbol	Min.	Typ.	Max.	Unit
Power supply voltage	VDE (DDRVDE)	1.7	1.8	1.9	V
	VDDI	1.10	1.20	1.30	V
Junction temperature	T <sub>J</sub>	-40	–	125	°C

The recommended operating conditions for the standard SSTL\_18 (excerpted from JESD8-15a).

**Table 8-6 USB2.0 Recommended Operating Conditions**

Parameter	Symbol	Value			Unit
		Min.	Typ.	Max.	
Supply voltage	USB_AVDF1	3.0	3.3	3.6	V
	USB_AVDB				
	USB_AVDF2	1.1	1.2	1.3	V
	USB_AVDP	1.1	1.2	1.3	V
Junction temperature	T <sub>J</sub>	-40	–	125	°C

Clock to be input to USB\_CRYCLK48 should meet followings:

- 48MHz±100ppm clock
- 100ps or less jitter

### Note:

The recommended operating conditions are primarily intended to assure the normal operation of semiconductor device. The values of electrical characteristics are guaranteed under the requirements above, so use the product accordingly. Using the product without observing the conditions may affect the product's reliability.

Performance of this product is not guaranteed using under the unspecified conditions and unspecified combination of logic. Be sure to contact Fujitsu when using the product under such conditions.

### 8.3. Precautions at Power On

#### 8.3.1. Recommended Power On/Off Sequence

Follow the power on/off sequence as shown below:

- <ON>: VDDI (internal and PLLVDD) → DDRVDE (external) → VDDE (external) → Signal
- <OFF>: Signal → VDDE (external) → DDRVDE (external) → VDDI (internal and PLLVDD)

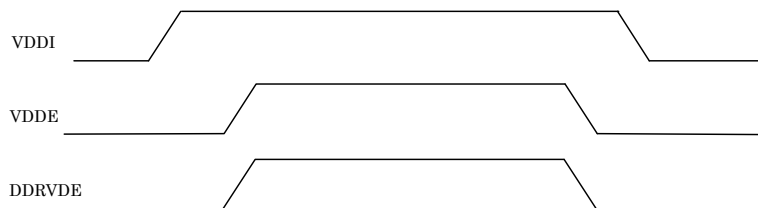

**Figure 8-1 Recommended Power On/Off Sequence (1)**

There is no limitation on the sequence of power on/off of VDDI, VDDE, and DDRVDE if the following condition is met. (Figure 8-2)

- Do not apply VDDE and DDRVDE (external) continuously more than 1 second when VDDI (internal) is off.

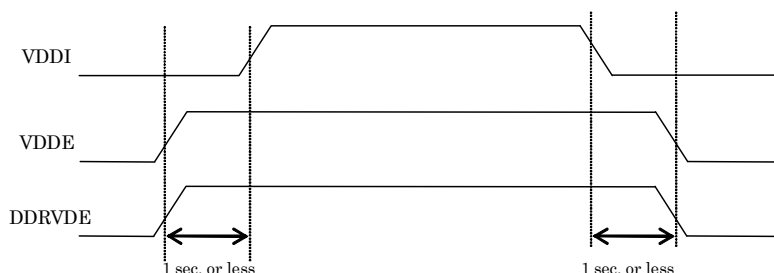

**Figure 8-2 Recommended Power On/Off Sequence (2)**

- Perform power on/off for VREF according to the DDR2-SDRAM regulation.
- Perform power on/off so that power for PLLVDD (PLL) does not exceed VDDI.
- Turn on all power. Turning on only a part of them is prohibited.
- CMOS IC becomes unstable immediately after power-on so that proceed reset immediately.
- Set the reset pins (XTRST and XRST) to Low when power-on.
- Input clock to CLK pin immediately after power-on.
- It requires at least 100 clocks (input clock to CLK pin) for the reset signal "L" applied to the XRST pin to be transmitted to all internal circuits.

### 8.3.2. Power On Reset

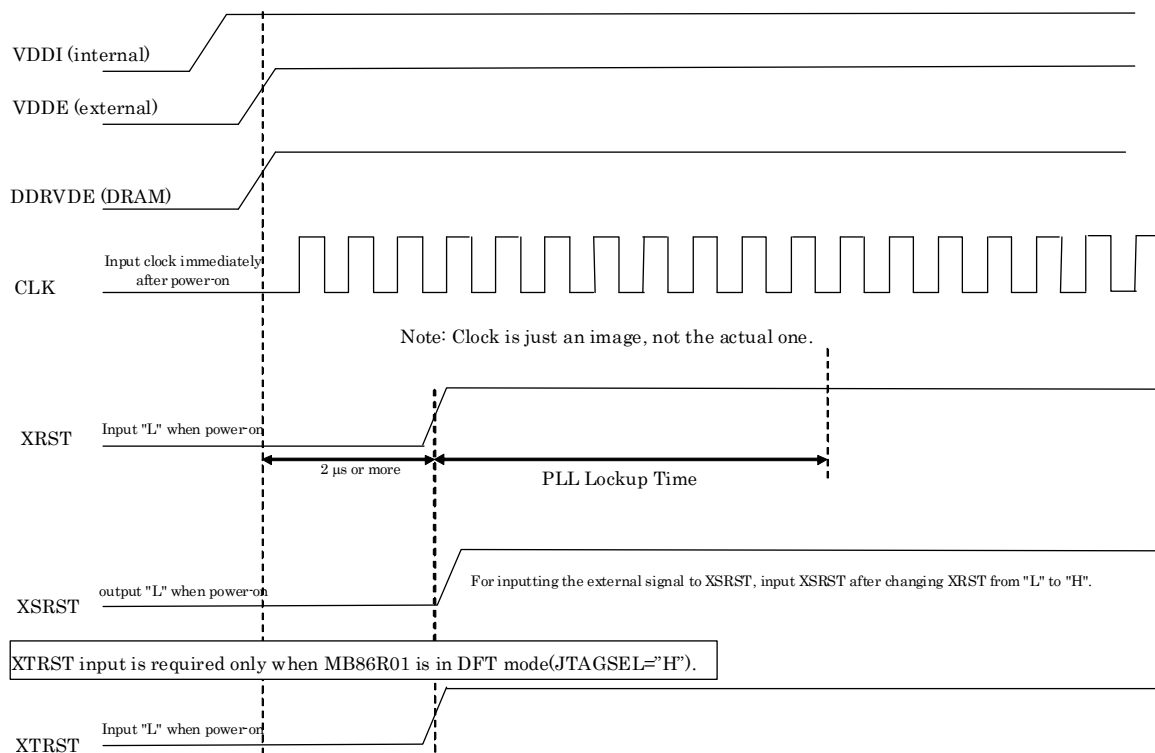

Figure 8-3 Power On Sequence

Input XRST pin to Low when power-on.  
 Keep XRST pin High after setting to Low level for  $2\ \mu\text{s}$  or more.  
 Access the other registers or memory controller after PLL Lockup Time.

When MB86R01 is in DFT mode, XTRST should be input as well as XRST.

## 8.4. DC Characteristics

### 8.4.1. 3.3V Standard CMOS I/O

Table 8-7 shows 3.3V standard CMOS I/O DC characteristics.

**Table 8-7 Standard CMOS I/O DC Characteristics**

Measurement condition: VDDE = 3.3 ±0.3V, VSS = 0V, T<sub>J</sub> = -40 to 125°C

Parameter	Symbol	Condition	Rating			Unit	
			Min.	Typ.	Max.		
H level input voltage	VIH		2.0	–	VDDE + 0.3	V	
L level input voltage	VIL		-0.3	–	0.8	V	
H level output voltage	VOH	IOH = -100μA	VDDE - 0.2	–	VDDE	V	
L level output voltage	VOL	IOL = 100μA	0	–	0.2	V	
H level output V-I characteristic	–	Driving capability 1	IOH = 4mA	See Figure 8-4, Figure 8-5, and Figure 8-6 characteristics			–
		Driving capability 2	IOH = 6mA				
		Driving capability 3	IOH = 8mA				
L level output V-I characteristic	–	Driving capability 1	IOL = 4mA				–
		Driving capability 2	IOL = 6mA				
		Driving capability 3	IOL = 8mA				
Input leakage current	IL		–	–	±4	μA	

Driving capabilities 1 to 3 in the table above indicate the following external pins:

Driving capability 1: TDO, MEM\_EA[24:1], MEM\_ED[15:0], MEM\_RDY, MEM\_XCS0, MEM\_XCS2, MEM\_XCS4, MEM\_XRD, MEM\_XWR0, MEM\_XWR1

Driving capability 2: VINHSYNC0, VINVSYNC0, I2S\_ECLK2, I2S\_SCK2, I2S\_SDO2, I2S\_WS2, IDE\_DD[15:0], IDE\_DINTRQ, IDE\_XCBLID, IDE\_XDASP, PWM\_O0, PWM\_O1, VIN10-7, VINFD1, DOUTB1[7:2], DOUTG1[7:2], DOUTR1[7:2], GV1, HSYNC0, HSYNC1, SD\_CMD, SD\_DAT[3:0], TRACECLK, TRACEDATA[3:0], VIN0[7:0], VSYNC0, VSYNC1, XSRST, DE0, DE1, DOUTB0[7:2], DOUTG0[7:2], DOUTR0[7:2], GV0, IDE\_CSEL, IDE\_DA[2:0], IDE\_XDCS[1:0], IDE\_XDDMACK, IDE\_XDIOR, IDE\_XDIOW, IDE\_XDRESET, RTCK, SD\_CLK, TRACECTL, UART\_SOUT[2:0], UART\_XRTS0, USB\_PRTPW

Driving capability 3: DCLKO[1:0]

### 8.4.1.1. 3.3V Standard CMOS I/O V-I Characteristic (Driving Capability 1)

Conditions	MIN: Process = Slow	$T_J = 125^\circ\text{C}$	$V_{DDE} = 3.0\text{ V}$
	TYP: Process = Typical	$T_J = 25^\circ\text{C}$	$V_{DDE} = 3.3\text{ V}$
	MAX: Process = Fast	$T_J = -40^\circ\text{C}$	$V_{DDE} = 3.6\text{ V}$

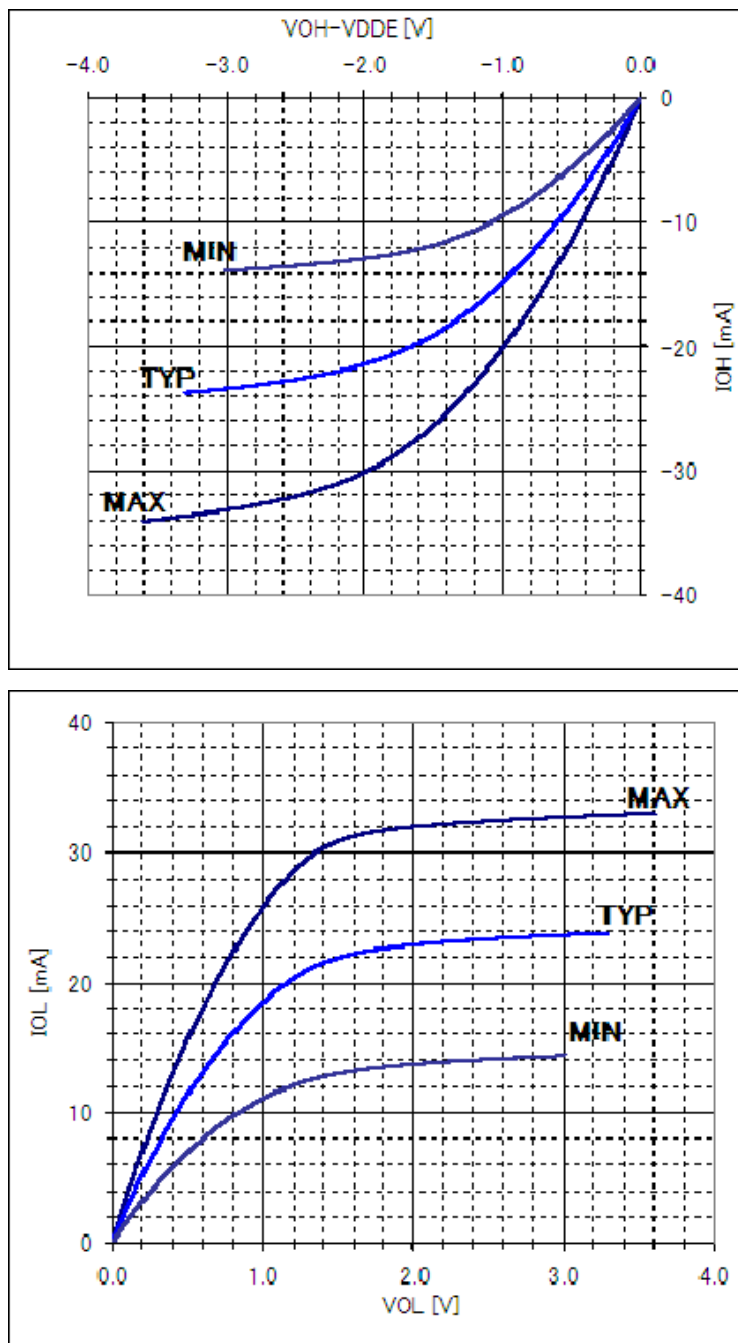

Figure 8-4 3.3V Standard CMOS I/O V-I Characteristic (Driving Capability 1)

**8.4.1.2. 3.3V Standard CMOS I/O V-I Characteristic (Driving Capability 2)**

Conditions	MIN: Process = Slow	$T_J = 125^\circ\text{C}$	$V_{DDE} = 3.0\text{ V}$
	TYP: Process = Typical	$T_J = 25^\circ\text{C}$	$V_{DDE} = 3.3\text{ V}$
	MAX: Process = Fast	$T_J = -40^\circ\text{C}$	$V_{DDE} = 3.6\text{ V}$

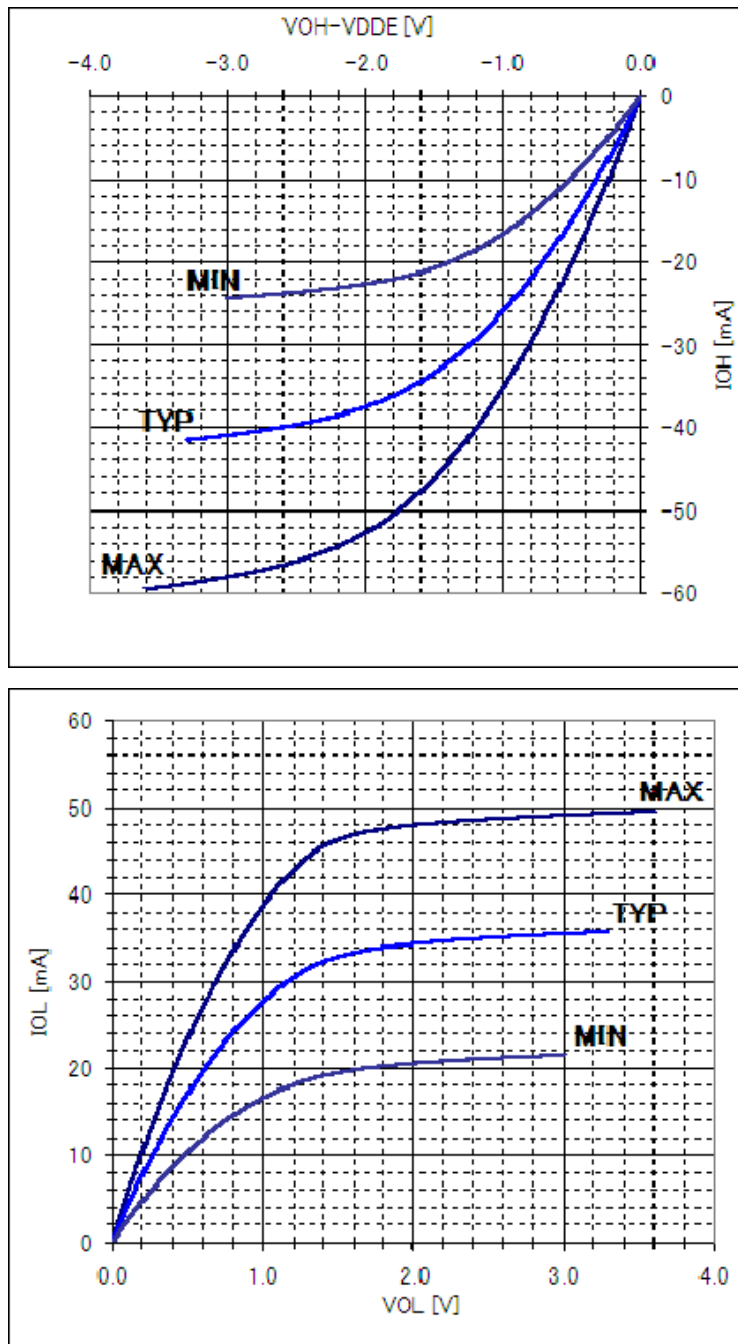

Figure 8-5 3.3V Standard CMOS I/O V-I Characteristic (Driving Capability 2)



### 8.4.1.3. 3.3V Standard CMOS I/O V-I Characteristics (Driving Capability 3)

Conditions	MIN: Process = Slow	$T_J = 125^\circ\text{C}$	$V_{DDE} = 3.0\text{ V}$
	TYP: Process = Typical	$T_J = 25^\circ\text{C}$	$V_{DDE} = 3.3\text{ V}$
	MAX: Process = Fast	$T_J = -40^\circ\text{C}$	$V_{DDE} = 3.6\text{ V}$

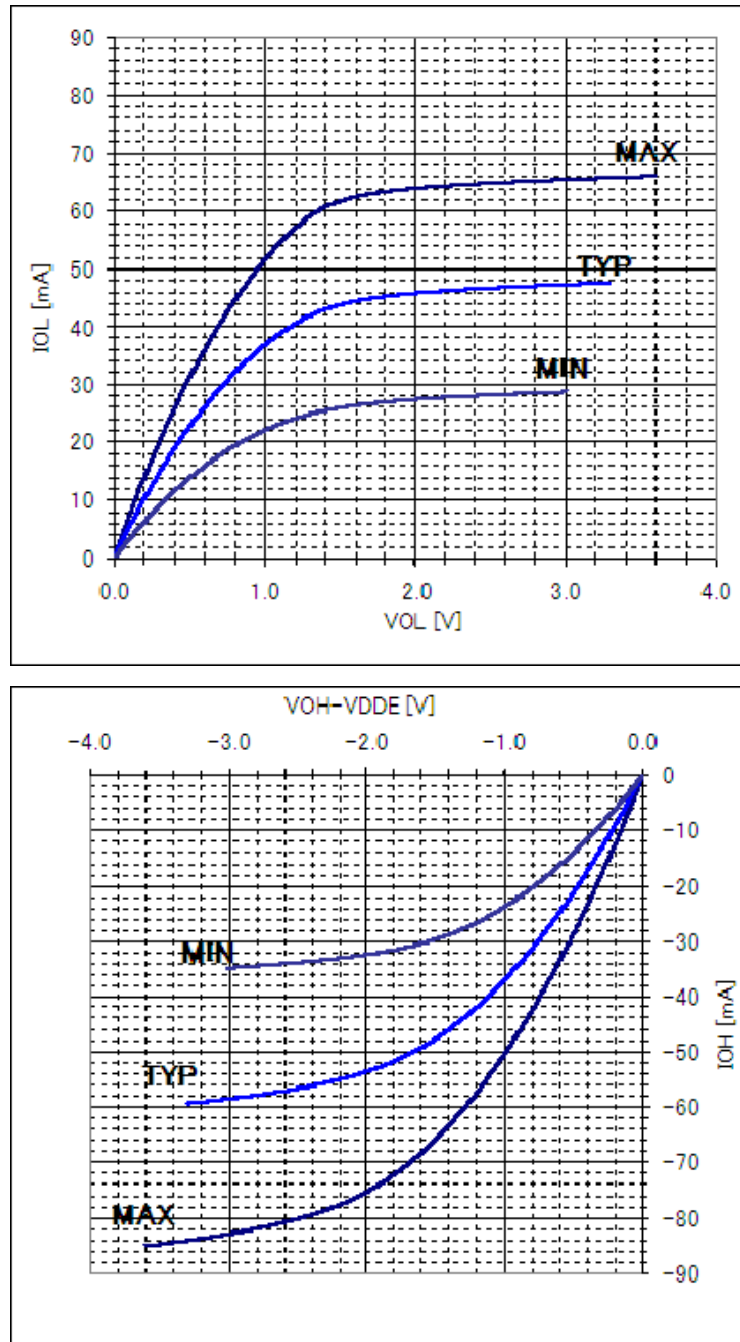

Figure 8-6 3.3 V Standard CMOS I/O V-I Characteristic (Driving Capability 3)

## 8.4.2. DDR2SDRAM IF I/O (SSTL\_18)

SSTL\_18 DC characteristics (excerpted from JESD8-15a).

**Table 8-8 SSTL18 Input DC Logic Levels (Single Ended)**

Symbol	Parameter	Min.	Max.	Unit
V <sub>IH</sub> (DC)	DC input logic High	VREF + 125	VDDQ + 300	mV
V <sub>IL</sub> (DC)	DC input logic Low	-300	VREF - 125	mV

**Table 8-9 SSTL18 Input AC Logic Levels (Single Ended)**

Symbol	Parameter	Min.	Max.	Unit
V <sub>IH</sub> (AC)	AC input logic High	VREF + 250	–	mV
V <sub>IL</sub> (AC)	AC input logic Low	–	VREF - 250	mV

**Table 8-10 SSTL18 Input AC Test Conditions (Single Ended)**

Symbol	Condition	Value	Unit
VREF	Input reference voltage	$0.5 \times VDDQ$	V
VSWING (max.)	Input single maximum peak to peak swing	1.0	V
SLEW	Input single minimum slew rate	1.0	V/ns

**Table 8-11 SSTL18 Input DC Logic Levels (Differential Ended)**

Symbol	Parameter	Min.	Max.	Unit
V <sub>IN</sub> (DC)	DC input signal voltage	-300	VDDQ + 300	mV
V <sub>ID</sub> (DC)	DC differential input voltage	250	VDDQ + 600	mV

**Table 8-12 SSTL18 Input AC Logic Levels (Differential Ended)**

Symbol	Parameter	Min.	Max.	Unit
V <sub>ID</sub> (AC)	AC differential input voltage	500	VDDQ + 600	mV
V <sub>IX</sub> (AC)	AC differential cross point voltage	$0.5 \times VDDQ - 175$	$0.5 \times VDDQ + 175$	mV

**Table 8-13 SSTL18 Input AC Test Conditions (Differential Ended)**

Symbol	Parameter	Min.	Max.	Unit
V <sub>r</sub>	Input timing measurement reference level	V <sub>IX</sub> (cross point)		V
VSWING	Input signal peak to peak swing voltage	–	1.0	V
SLEW	Input signal slew rate	1.0	–	V/ns

**Table 8-14 SSTL18 Output DC Current Drive**

Symbol	Parameter	Min.	Max.	Unit	Notes
I <sub>OH</sub> (DC)	Output minimum source DC current	-11.4 (*3)	–	mA	(*1)
I <sub>OL</sub> (DC)	Output minimum sink DC current	11.4 (*3)	–	mA	(*2)

\*1: VDDQ = 1.7V, VOUT = 1420mV

\*2: VDDQ = 1.7V, VOUT = 280mV

\*3: The value is different from JESD8-15a. (JESD8-15a:  $\pm 13.4$ mA)

**Table 8-15 SSTL18 Differential AC parameters**

Symbol	Parameter	Min.	Max.	Unit
VOX	AC differential cross point voltage	$0.5 \times VDDQ - 125$	$0.5 \times VDDQ + 125$	mV

**Note:**

External pin for DDR2SDRAM IO buffer is as follows.

MDQSP[3:0], MDQSN[3:0], MDM[3:0], MDQ[31:0], MCKP, MCKN, MA[13:0], MBA[1:0],  
MCAS, MCKE, MCS, MRAS, MWE, ODTCONT, OCD, ODT, VREF0, VREF1

### 8.4.3. ADC

**Table 8-16 Recommended Operating Conditions**

Parameter	Symbol	Value			Unit
		Min.	Typ.	Max.	
Power supply voltage	AD_AVD0	2.70	3.00	3.60	V
Reference voltage (H)	AD_VRH0 AD_VRH1	AD_AVD0*0.75	–	AD_AVD0	V
Reference voltage (L)	AD_VRL0 AD_VRL1	V <sub>SS</sub> (*1)	–	AD_AVD0*0.25	V
Decoupling capacitor	AD_VR0 (*2) AD_VR1 (*2)	0.05	–	–	μF
Analog input voltage	AD_VIN0 AD_VIN1	AD_VRL0 AD_VRL1	–	AD_VRH0 AD_VRH1	V
Analog input frequency	AD_VIN0 AD_VIN1	0	–	500	kHz

**Note:**

\*1: V<sub>SS</sub> = AD\_AVS1 (analogue GND)

\*2: In the case that VR is decoupled with AVS by decoupling capacitor, A/D outputs incorrect result at immediately after power-on or at the resumption from power down mode.

Because charge current for decoupling capacitors is supplied through the reference resistance, it takes about 2ms to get correct result (it is the case decoupling capacitor is 0.1μF.).

**Table 8-17 ADC Characteristics**

(VDD = 1.2V, AVD = 3.0V, FS = 100KS/s, FC = 1.4MHz, FVIN = 1 kHz, T<sub>A</sub> = 25°C (\*1))

Parameter	Symbol	Value			Unit
		Min.	Typ.	Max.	
Supply current (included reference current)	AD_AVD0	–	0.8	1.2	mA
		-1	–	50	μA
Reference voltage (M)	AD_VR0 AD_VR1	–	AD_AVD0/2	–	V
		-3	–	3	%
Reference resistance	AD_VRH0 AD_VRH1 AD_VRL0 AD_VRL1	7.3	9	10.7	kΩ
Zero transition voltage (*2)		Typ. -20	AD_VRL0+1LSB AD_VRL1+1LSB	Typ. +20	mV
Full scale transition Voltage (*2)		Typ. -20	AD_VRH0-1LSB AD_VRH1-1LSB	Typ. +20	mV
Integral non linearity (*3)		-2.0	–	+2.0	LSB
Differential non linearity (*3)		-1.5	–	+1.5	LSB

\*1: VR is connected to AVS with decoupling capacitor (0.1μF).

Unique voltage is supplied to VRH and VRL by voltage source.

\*2: VZT and VFST are dependent on chip layout and wiring resistance.

\*3: 1LSB = (VFST-VZT)/1022, INL<sub>n</sub> = ((1LSB×n + VZT) - V<sub>n</sub>)/1LSB, DNL<sub>n</sub> = (V<sub>n+1</sub> - V<sub>n</sub>)/1LSB - 1

## 8.4.4. I<sup>2</sup>C Bus Fast Mode I/O

**Table 8-18 I<sup>2</sup>C I/O DC Characteristics**

Parameter & Condition	Symbol	Standard Mode		Fast Mode (*1)		Unit
		Min.	Max.	Min.	Max.	
"L" level input voltage	VIL	-0.5	0.3 VDDE	-0.5	0.3 VDDE	V
"H" level input voltage	VIH	0.7 VDDE	(*2)	0.7 VDDE	(*2)	V
Schmitt trigger hysteresis VDDE > 2[v]	Vhys	n/a	n/a	0.05 VDDE	–	V
"L" level output voltage Sink current 3[mA] VDDE > 2[v]	VOL1	0	0.4	0	0.4	V
Output slew rate (Tfall) Bus capacitance 10[pF] ~ 400[pF] VIH (min.) to VIL (max.)	tof	–	250	20 + 0.1Cb (*3)	250	ns
Data line leakage Input voltage 0.1 ~ 0.9 VDDE (max.)	Ii	-10	10	-10	10	μA
I/O pin capacitance	Ci	–	10	–	10	pF

\*1: The I<sup>2</sup>C Bus Fast Mode I/O buffer is downward compatible with standard mode.

\*2: 90nm Technology: Complies with the maximum ratings 4[V].

\*3: Cb: Capacitance for 1 bus line (Unit: pF).

\*4: The I<sup>2</sup>C Bus Fast Mode I/O buffer itself has no function to prevent spike of 50ns pulse width (max.). Therefore, provide any input filter to prevent spike for both internal and external semiconductor device.

**Note:**

External pin for I<sup>2</sup>C IO buffer is as follows.

I2C\_SCL0, I2C\_SDA0, I2C\_SCL1, I2C\_SDA1

8.4.4.1. I<sup>2</sup>C IO V-1 Characteristic Figure

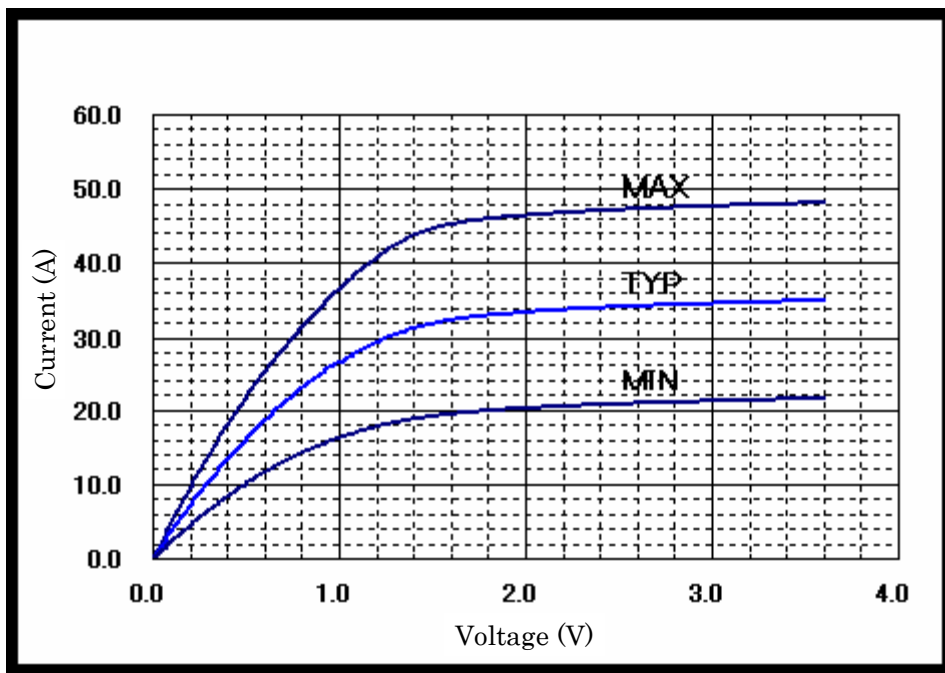

Figure 8-7 I<sup>2</sup>C V-I Characteristic Figure

## 8.4.5. USB2.0

**Table 8-19 Recommended Operating Conditions (High-speed)**

Parameter	Symbol	Value			Unit
		Min.	Typ.	Max.	
Input levels for high-speed:					
high-speed squelch detection threshold (differential signal amplitude)	VHSSQ	100	–	200	mV
High-speed disconnect detection threshold (differential signal amplitude)	VHSDSC	525	–	625	mV
High-speed differential input signaling levels (this spec is based on "Template 6")		150 (the absolute value)	–	–	mV
High-speed data signaling common mode voltage range (guideline for receiver)	VHSCM	-50	–	500	mV
Output levels for high-speed:					
High-speed idle level	VHSOI	-10.0	–	10.0	mV
High-speed data signaling high	VHSOH	360	–	440	mV
High-speed data signaling low	VHSOL	-10.0	–	10.0	mV
Chirp J level (differential voltage)	VCHIRPJ	700	–	1100	mV
Chirp K level (differential voltage)	VCHIRPK	-900	–	-500	mV
Terminations in high-speed:					
Termination voltage in high-speed	VHSTERM	-10	–	10	mV

**Table 8-20 Recommended Operating Conditions (Full-speed/Low-speed)**

Parameter	Symbol	Value			Unit
		Min.	Typ.	Max.	
Input levels for full-speed/low-speed:					
High (driving)	VIH	2.0	–	–	V
High (floating)	VIHZ	2.7	–	3.6	V
Low	VIL	–	–	0.8	V
Differential input sensitivity	VDI	0.2	–	–	V
Differential common mode range	VCM	0.8	–	2.5	V
Output levels for full-speed/low-speed:					
Low	VOL	0.0	–	0.3	V
High (driven)	VOH	2.8	–	3.6	V
SE1	VOSE1	0.8	–	–	V
Output signal crossover voltage	VCRS	1.3	–	2.0	V
Input capacitance for full-speed/low-speed:					
Downstream facing port (being shared with upstream facing port at device mode, so the less value is selected as the maximum spec)	CIND (CINUB)	–	–	100	pF
Transceiver edge rate control capacitance	CEGE	–	–	75	pF
Terminations in full-speed/low-speed:					
Bus pull-up resistor on upstream port (idle bus) (this is used only in the device mode (HOSTMODE = "0" setting).)	RPUI	0.9	–	1.575	k $\Omega$
Bus pull-up resistor on upstream port (upstream port receiving) (this is used only in the device mode (HOSTMODE = "0" setting).)	RPUA	1.425	–	3.090	k $\Omega$
Input impedance exclusive of pull-up/pull-down	ZINP	300	–	–	k $\Omega$
Termination voltage on upstream port pull-up	VTERM	3.0	–	3.6	V

## 8.5. AC CHARACTERISTIC

In this chapter, the AC timing of external ports is described.

### 8.5.1. Memory Controller Signal Timing

**Table 8-21 Memory Controller AC Timing**

Signal Name	Symbol	Description	Value			Unit
			Min	Typ	Max	
MEM_XCS0 MEM_XCS2 MEM_XCS4	$t_{cso}$	Chip Select delay time	–	–	10	ns
MEM_EA[24:1]	$t_{ao}$	Address delay time	–	–	11	ns
MEM_ED[31:0]	$t_{do}$	Data output delay time	–	–	11	ns
	$t_{doz}$	Data output HiZ time	–	–	12	ns
	$t_{dsr}$	SRAM/NOR Flash data setup time	12	–	–	ns
	$t_{dhr}$	SRAM/NOR Flash data hold time	0	–	–	ns
	$t_{dsp}$	NOR Flash page Read data setup time	13	–	–	ns
	$t_{dhp}$	NOR Flash page Read data hold time	0	–	–	ns
MEM_XRD	$t_{rdo}$	XRD delay time	–	–	10	ns
MEM_XWR[3:0]	$t_{wro}$	XWR delay time	–	–	10	ns

Standard clock of output delay is internal clock.

Standard clock of MEM\_RDY is internal clock.



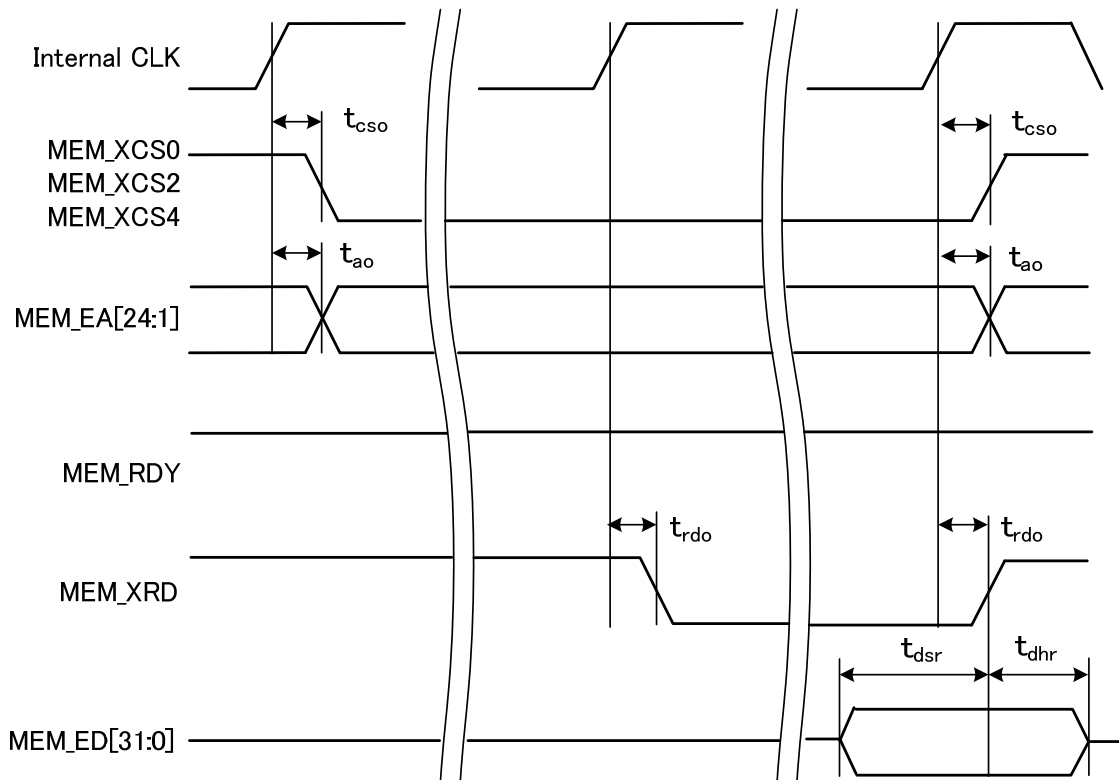

Figure 8-8 SRAM/NOR Flash Read

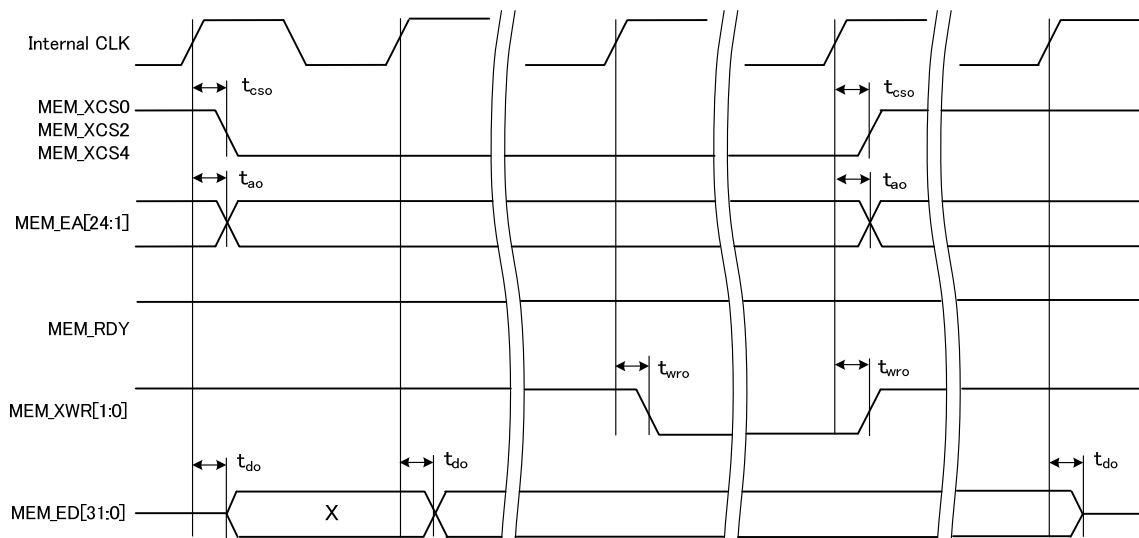

Figure 8-9 SRAM/NOR Flash Write

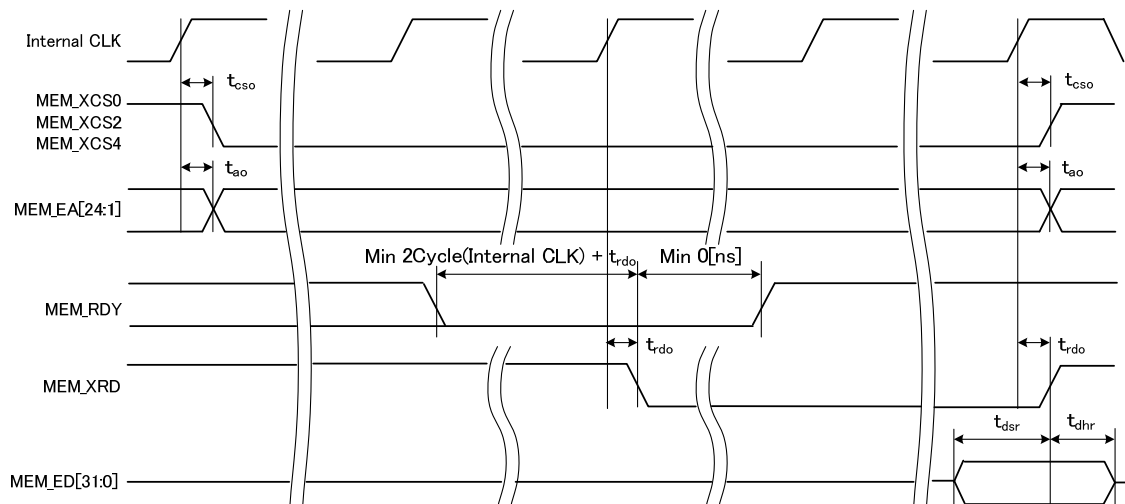

Figure 8-10 Low speed device Read

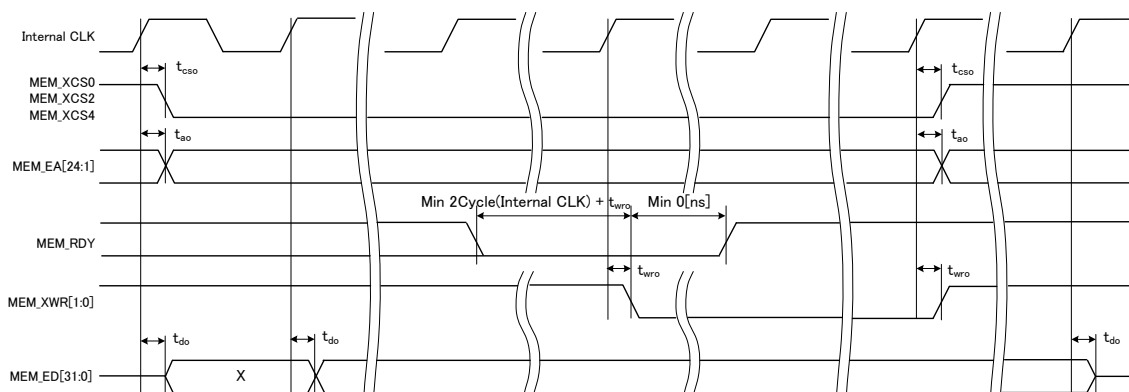

Figure 8-11 Low speed device Write

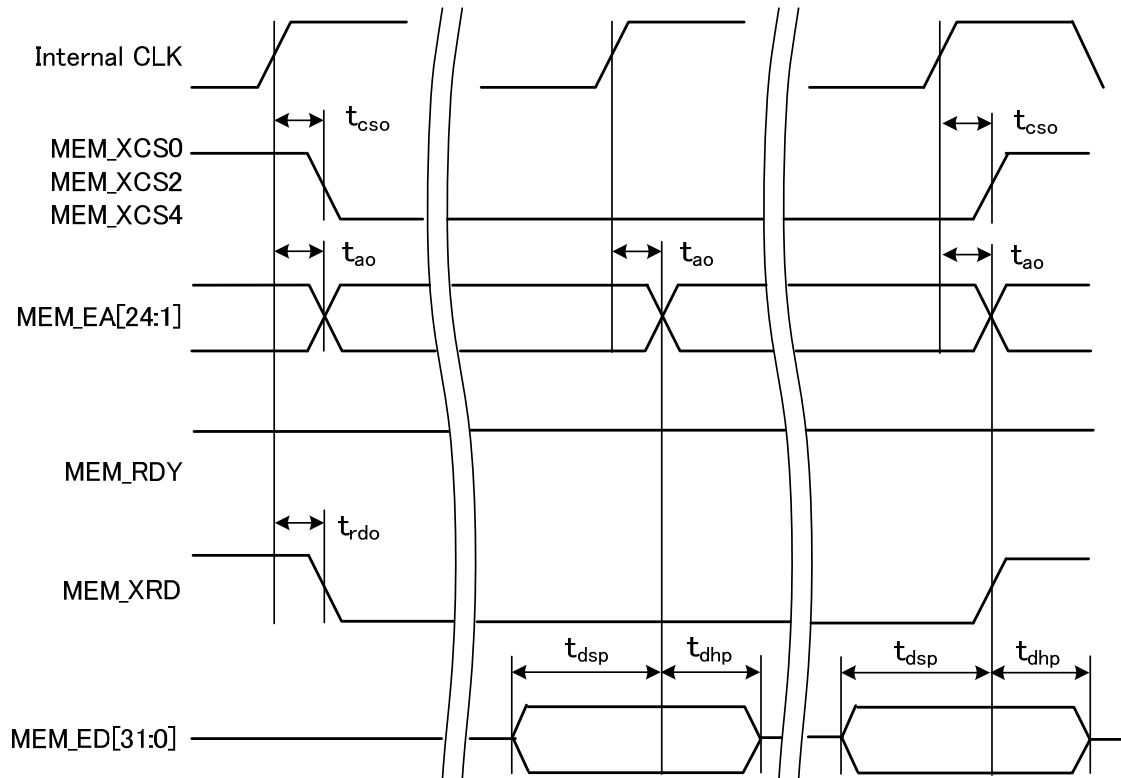

Figure 8-12 NOR Flash Page Read

## 8.5.2. DDR2SDRAM IF

This is able to connect with DDR2 SDRAM which is in conformance with DDR2-400 in the JEDEC (JESD79-2C.) Timing regulation is described below, and output load condition is according to the PCB design guideline.

**Table 8-22 Write Spec (1 and 2): CK-CMD/ADD and CK-DQS**

Item	Symbol	Spec formula	Criteria value (*1)			Unit
			Min.	Typ.	Max.	
CMD/ADD setup valid-data from CK↑	tVD_setup_CMD	(tCK/2) - 828	2172	-	-	ps
CMD/ADD hold valid-data from CK↑	tVD_hold_CMD	(tCK/2) - 545	2455	-	-	ps
Skew between DQS↑ vs. CK↑	tSkew_DQS_CK	Not tCK dependent	-1083	-	772	Ps

\*1: Spec for tck = 6ns (333Mbps) is indicated

**Table 8-23 Write Spec (3): DQ-DQS**

Item	Symbol	Spec formula	Criteria value (*1)			Unit
			Min.	Typ.	Max.	
DQ/DM setup valid-data from DQS	tVD_setup_DQ	(tCK/4) - 884	616	-	-	ps
DQ/DM hold valid-data from DQS	tVD_hold_DQ	(tCK/4) - 776	724	-	-	ps

\*1: Spec for tck = 6ns (333Mbps) is indicated

**Table 8-24 Read Spec (1): DQ-DQS**

Item	Symbol	Spec formula	Criteria value (*1)			Unit
			Min.	Typ.	Max.	
tSETUP DQ from DQS	tSETUP_DQ	- (0.1875*tCK - 208 )	-917	-	-	ps
tHOLD DQ from DQS	tHOLD_DQ	0.1875*tCK + 503	1628	-	-	Ps

\*1: Spec for tck = 6ns (333Mbps) is indicated

**Table 8-25 Read Spec (2): DQ-R.T.T (RoundTrip Time)**

Item	Symbol	Spec formula	Criteria value (*1)			Unit
			Min.	Typ.	Max.	
DQS RoundTripTime @CL = 3 (CK_out DRAM DQS_in)	tRTT_DQS	<Max.> 1112 <Min.> -595	-355	-	+1426	ps

\*1: Spec for tck = 6ns (333Mbps) is indicated

\*2: Spec shows total delay value including tDQCK delay of DRAM

8.5.2.1. DDR2SDRAM IF Timing Diagram

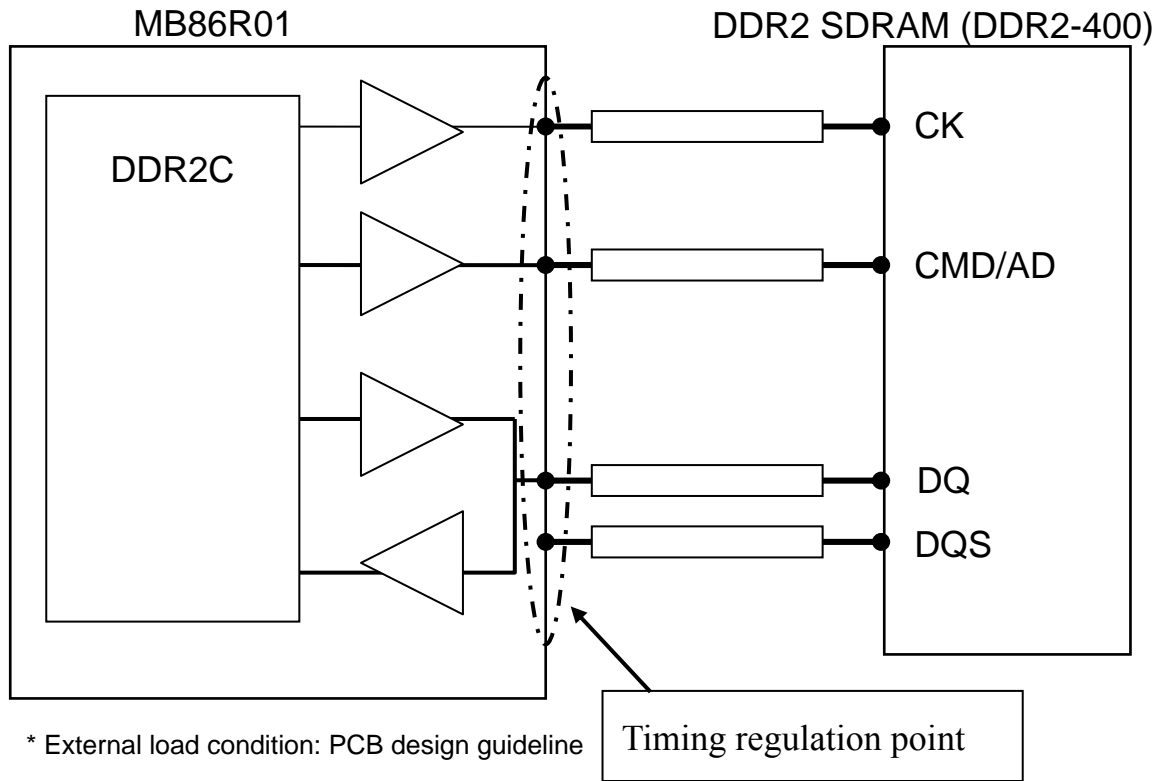

Figure 8-13 Timing Regulation Point

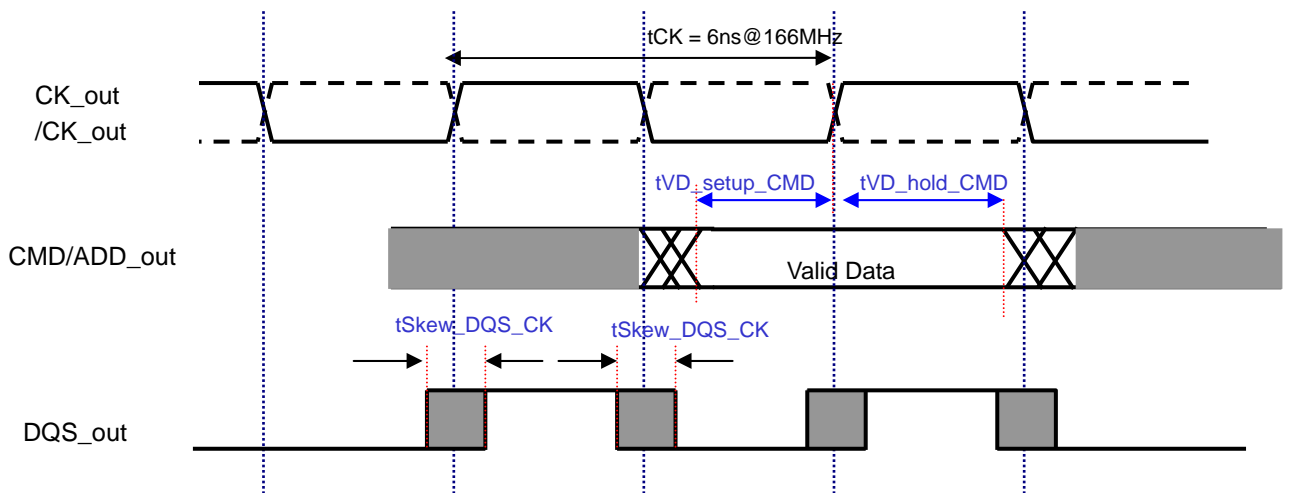

Figure 8-14 Write Spec (1 and 2): CK-CMD/ADD and CK-DQS

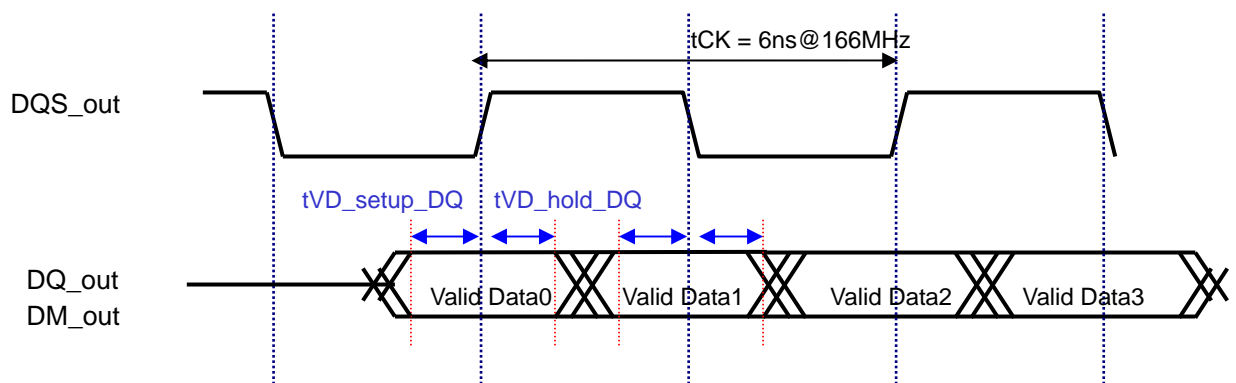

Figure 8-15 Write Spec (3): DQ-DQS

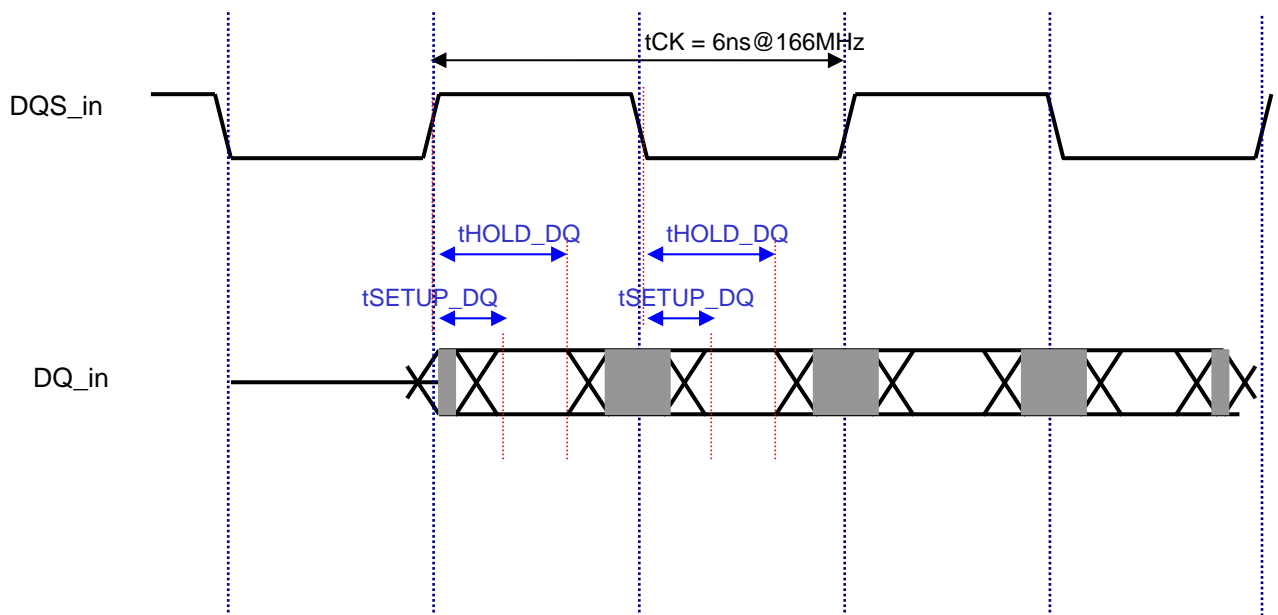

Figure 8-16 Read Spec (1): DQ-DQS

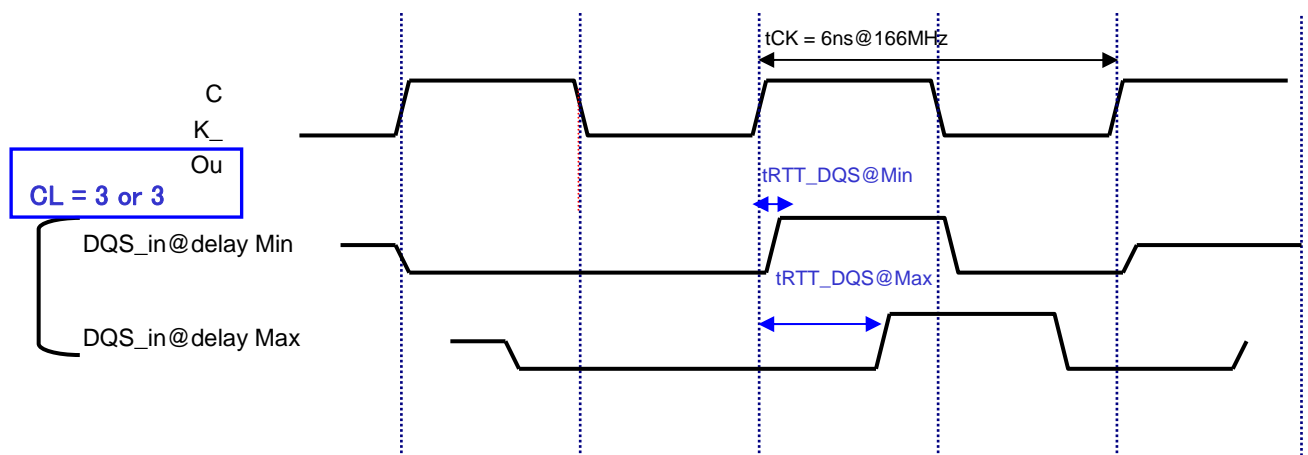

Figure 8-17 Read Spec (2): DQS-R.T.T (RoundTrip Time)

### 8.5.3. GPIO Signal Timing

**Table 8-26 AC Timing**

Signal	Symbol	Description	Value			Unit
			Min.	Typ.	Max.	
GPIO_PD[23:0]	$t_{do}$	Data output delay time	–	–	13	ns
	$t_{dw}$	Input data-width	A	–	–	Ns

Internal clock is the standard of output delay.

A indicates APB bus clock cycle, and it is different from the output delay standard clock.

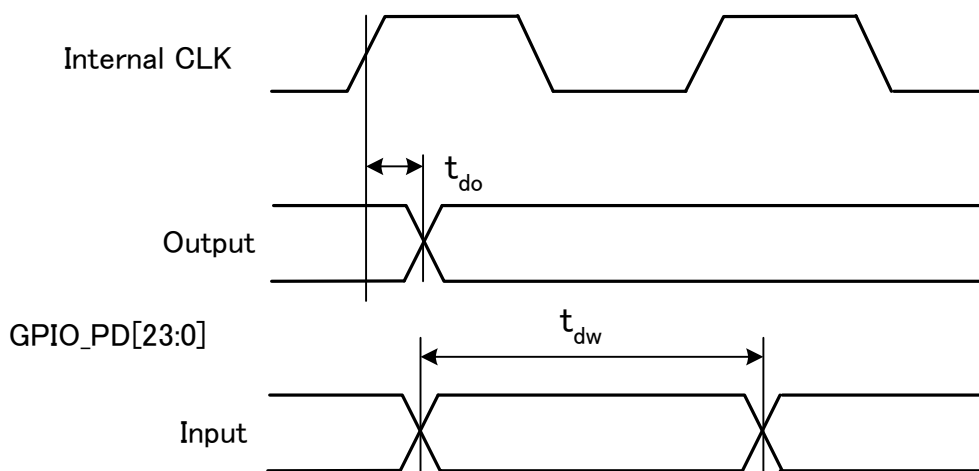

**Figure 8-18 GPIO Timings**



## 8.5.4. PWM Signal Timing

### 8.5.4.1. Output Signal

**Table 8-27 AC Timing of Ide Data Input Signal**

Signal	Symbol	Description	Value			Unit
			Min.	Typ.	Max.	
PWM_O0	T0	Output delay of PWM_O0 based on APB-BusClock	2.0	–	14.0	ns
PWM_O1	T1	Output delay of PWM_O1 based on APB-BusClock	2.0	–	14.0	ns

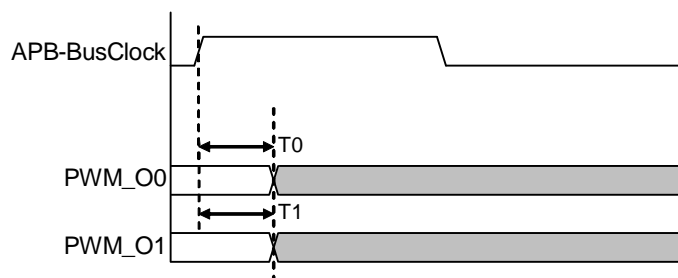

**Figure 8-19 PWM Output Timing**

## 8.5.5. GDC Display Signal Timing

### 8.5.5.1. Clock

**Table 8-28 AC timing of Video Interface Clock Signal**

Signal	Symbol	Description	Value			Unit
			Min.	Typ.	Max.	
DCLKI0	Fdclki0	DCLKI frequency	–	–	80	MHz
	Thdclki0	DCLKI H width	5	–	–	ns
	Tldclki0	DCLKI L width	5	–	–	ns
DCLKI1	Fdclki1	DCLKI frequency	–	–	80	MHz
	Thdclki1	DCLKI H width	5	–	–	ns
	Tldclki1	DCLKI L width	5	–	–	ns
DCLK (internal)	Tldclk0	DCLK frequency (*1)	–	–	80	MHz
DCLK (internal)	Tldclk1	DCLK frequency (*1)	–	–	80	MHz
DCLKO0	Fdclko	DCLKO frequency	–	–	80	MHz
DCLKO1	Fdclko	DCLKO frequency	–	–	80	MHz

\*1: Internal display clock of PLL synchronization mode is generated by division of internal PLL in the display clock prescaler.

\*2: DCLKI or internal display clock of PLL is output.

### 8.5.5.2. Input Signal

#### 1) Applied the signal only in PLL synchronization mode (CKS = 0)

(Reference clock = Clock output from internal PLL)

**Table 8-29 AC Timing of Video Interface Input Signal (1)**

Signal	Symbol	Description	Value			Unit
			Min.	Typ.	Max.	
HSYNC0 (i)	Twhsync0	HSYNC input pulse width	3.0	–	–	Clock
HSYNC1 (i)	Twvsync1	VSYNC input pulse width	3.0	–	–	Clock
VSYNC0 (i)	Twvsync	VSYNC input pulse width	1	–	–	HSYNC
VSYNC1 (i)	Twvsync	VSYNC input pulse width	1	–	–	HSYNC

#### 2) Applied the signal only in DCLKI synchronization mode (CKS = 1)

(Reference clock = DCLKI)

**Table 8-30 AC Timing of Video Interface Input Signal (2)**

Signal	Symbol	Description	Value			Unit
			Min.	Typ.	Max.	
HSYNC0 (i)	Twhsync0	HSYNC input pulse width	3.0	–	–	Clock
	Tshsync0	HSYNC Input setup time	6.0	–	–	ns
	Thhsync0	HSYNC Input hold time	1.0	–	–	ns
HSYNC1 (i)	Twhsync1	HSYNC input pulse width	3.0	–	–	Clock
	Tshsync1	HSYNC Input setup time	6.0	–	–	ns
	Thhsync1	HSYNC Input hold time	1.0	–	–	ns
VSYNC0 (i)	Twvsync0	VSYNC input pulse width	1	–	–	HSYNC
VSYNC1 (i)	Twvsync1	VSYNC input pulse width	1	–	–	HSYNC

### 8.5.5.3. Output Signal

**Table 8-31 AC Timing of Video Interface Input Signal**

Signal	Symbol	Description	Value			Unit
			Min.	Typ.	Max.	
DOUTR0[5:0], DOUTG0[5:0], DOUTB0[5:0]	Tdrgb0	RGB output delay time	0	–	5.5	ns
DOUTR1[5:0], DOUTG1[5:0], DOUTB1[5:0]	Tdrgb1	RGB output delay time	0	–	5.5	ns
HSYNC0 (o)	Tdhsync0	HSYNC output delay time	0	–	5.5	ns
HSYNC1 (o)	Tdhsync1	HSYNC output delay time	0	–	5.5	ns
VSYNC0 (o)	Tdvsync0	VSYNC output delay time	0	–	5.5	ns
VSYNC1 (o)	Tdvsync1	VSYNC output delay time	0	–	5.5	ns
CSYNC0	Tdcsync0	CSYNC output delay time	0	–	5.5	ns
CSYNC1	Tdcsync1	CSYNC output delay time	0	–	5.5	ns
GV0	Tdgv0	GV output delay time	0	–	5.5	ns
GV1	Tdgv1	GV output delay time	0	–	5.5	Ns

Note: If hold time is deficient, inverting DCLKO clock is recommended.

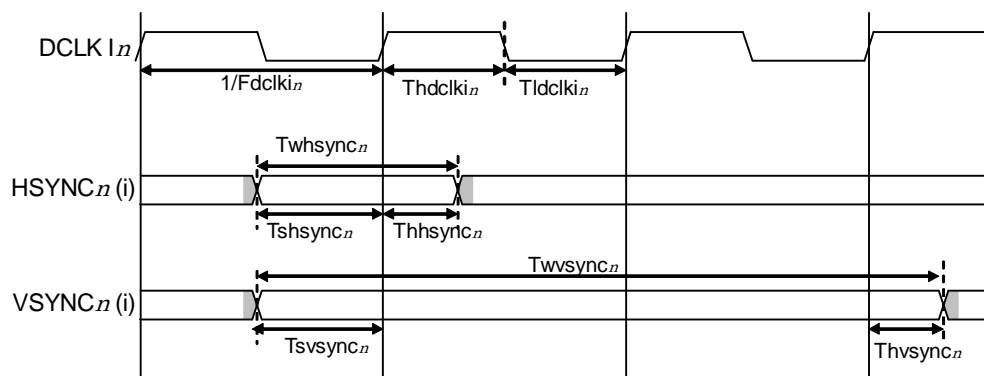

**Figure 8-20 Display Input Signal Timing**

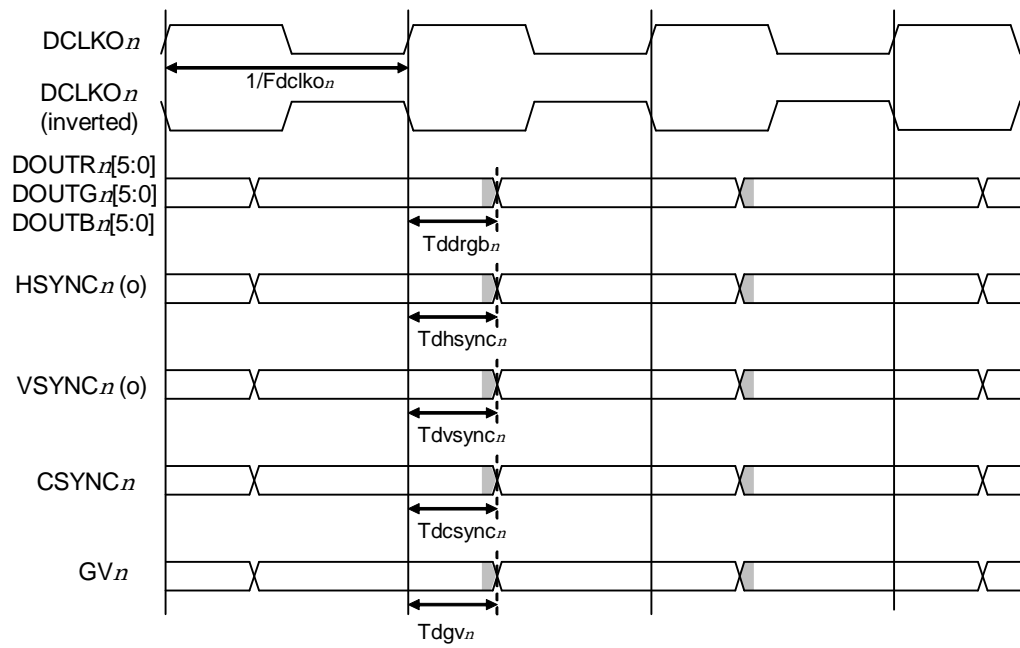

**Figure 8-21 Display Output Signal Timing**

There is no definition of AC characteristics about analog signal.

## 8.5.6. GDC Video Capture Signal Timing

### 8.5.6.1. Clock

**Table 8-32 AC Timing of Video Capture Interface Clock Signal**

Signal	Symbol	Description	Value			Unit
			Min.	Typ.	Max.	
CCLK0, CCLK1	$f_{CCLK}$	Capture clock frequency	–	–	80	MHz
	$t_{HCCLK}$	Capture clock H width	3	–	–	ns
	$t_{LCCLK}$	Capture clock L width	3	–	–	ns

Note: It depends on the resolution of the video source.

### 8.5.6.2. Input Signal

**Table 8-33 AC Timing of Video Capture Interface Input Signal**

Signal	Symbol	Description	Value			Unit
			Min.	Typ.	Max.	
VIN0[7:0], VIN1[7:0]	$t_{SVI}$	Input setup time	6	–	–	ns
	$t_{HVI}$	Input hold Time	1	–	–	ns
RI1[7:2]	$t_{SRI}$	Input setup time	6	–	–	ns
	$t_{HRI}$	Input hold Time	1	–	–	ns
GI1[7:2]	$t_{SGI}$	Input setup time	6	–	–	ns
	$t_{HGI}$	Input hold Time	1	–	–	ns
BI1[7:2]	$t_{SBI}$	Input setup time	6	–	–	ns
	$t_{HBI}$	Input hold Time	1	–	–	ns
VINHSYNC0, VINHSYNC1	$t_{SHSI}$	Input setup time	6	–	–	ns
	$t_{HHSI}$	Input hold Time	1	–	–	ns
VINVSYNC0, VINVSYNC1	$t_{SVSI}$	Input setup time	6	–	–	ns
	$t_{HVSI}$	Input hold Time	1	–	–	ns
VINFID0, VINFID1	$t_{SFI}$	Input setup time	6	–	–	ns
	$t_{HFI}$	Input hold Time	1	–	–	ns

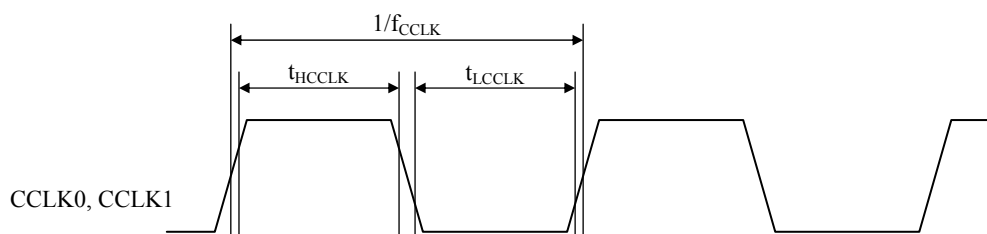

**Figure 8-22 Video Capture Clock Input Signal Timing**

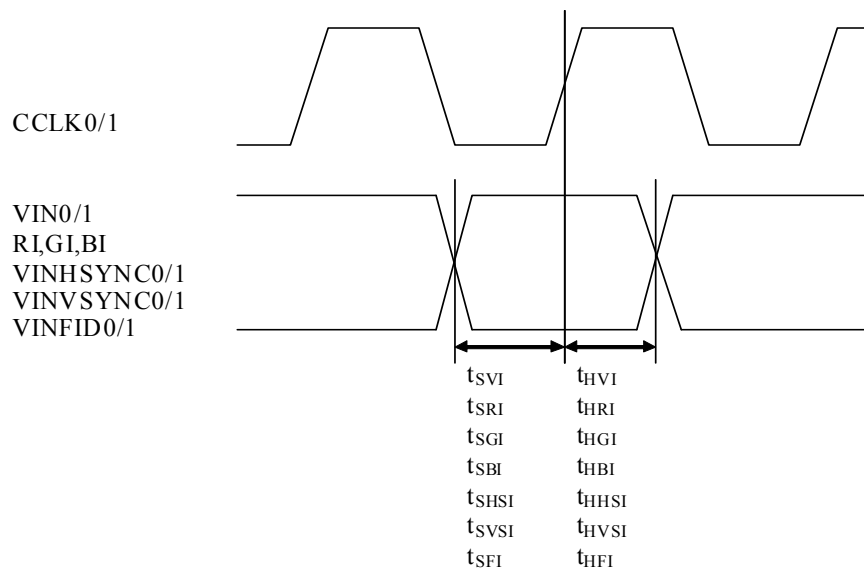

Figure 8-23 Video Capture Input Signal Timing

## 8.5.7. I2S Signal Timing

**Table 8-34 Timing Requirements**

Signal	Symbol	Description	Value			Unit
			Min.	Typ.	Max.	
I2S_SCKx	$t_{scyc}$	Operating frequency, I2S_SCKx (slave Mode)	–	–	0.5*B	MHz
	$t_{shw}$	Pulse duration, I2S_SCKx High (slave Mode)	0.45*T	–	0.55*T	ns
	$t_{slw}$	Pulse duration, I2S_SCKx Low (slave Mode)	0.45*T	–	0.55*T	ns
I2S_WSx	$t_{sfi}$	Setup time, external I2S_WSx High before I2S_SCKx Low (slave mode)	8	–	–	ns
	$t_{hfi}$	Hold time, external I2S_WSx High after I2S_SCKx Low (slave Mode)	4	–	–	ns
I2S_SDIx	$t_{sdi}$	Setup time, I2S_SDIx valid before I2S_SCKx Low (master mode)	8	–	–	ns
		Setup time, I2S_SDIx valid before I2S_SCKx Low (slave Mode)	8	–	–	ns
	$t_{hdi}$	Hold time, I2S_SDIx valid after I2S_SCKx Low (master mode)	4	–	–	ns
		Hold time, I2S_SDIx valid after I2S_SCKx Low (slave mode)	4	–	–	ns

B indicates AHB bus clock frequency.

T indicates I2S\_SCKx cycle.

**Table 8-35 Switching Characteristics**

Signal	Symbol	Description	Value			Unit
			Min.	Typ.	Max.	
I2S_SCKx	$t_{mcyce}$	Operating frequency, I2S_SCKx (master mode)	–	–	0.5*B	MHz
	$t_{mhw}$	Pulse duration, I2S_SCKx high (master mode)	0.45*T	–	0.55*T	ns
	$t_{mlw}$	Pulse duration, I2S_SCKx low (master mode)	0.45*T	–	0.55*T	ns
I2S_WSx	$t_{dfs}$	Delay time, I2S_SCKx High to I2S_WSx transition (master mode)	-12	–	12	ns
I2S_SDOx	$t_{ddo}$	Delay time, I2S_SCKx High to I2S_SDOx valid except the first bit of transmit frame. (master mode)	-12	–	17	ns
		Delay time, I2S_SCKx high to I2S_SDOx valid except the first bit of transmit frame. (slave mode)	3	–	32	ns
	$t_{dfb1}$	Delay time, I2S_SCKx high to the first bit of a transmit frame when FSPH bit of I2Sx_CNTREG register is 1. (master mode)	-14	–	17	ns

B indicates AHB bus clock frequency.

T indicates I2S\_SCKx cycle.

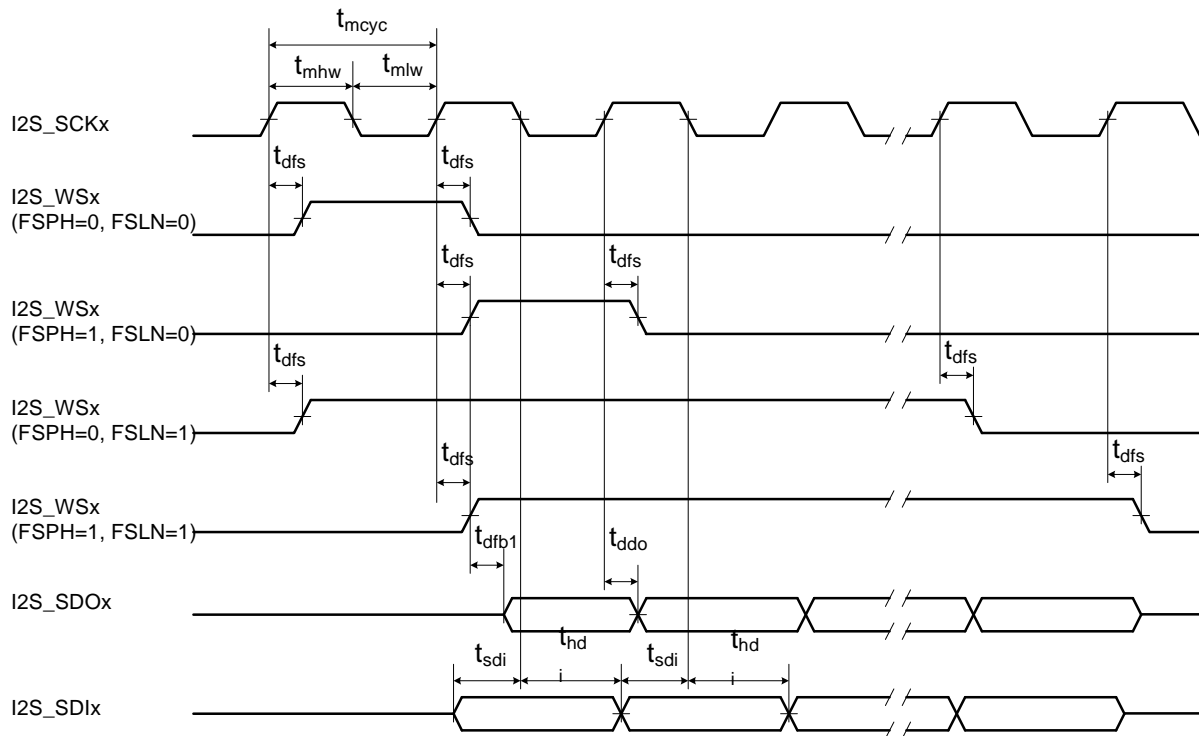

FSPH is bit 2 of I2Sx\_CNTREG register.  
 FSLN is bit 1 of I2Sx\_CNTREG register.

**Figure 8-24 Master Mode Timing**

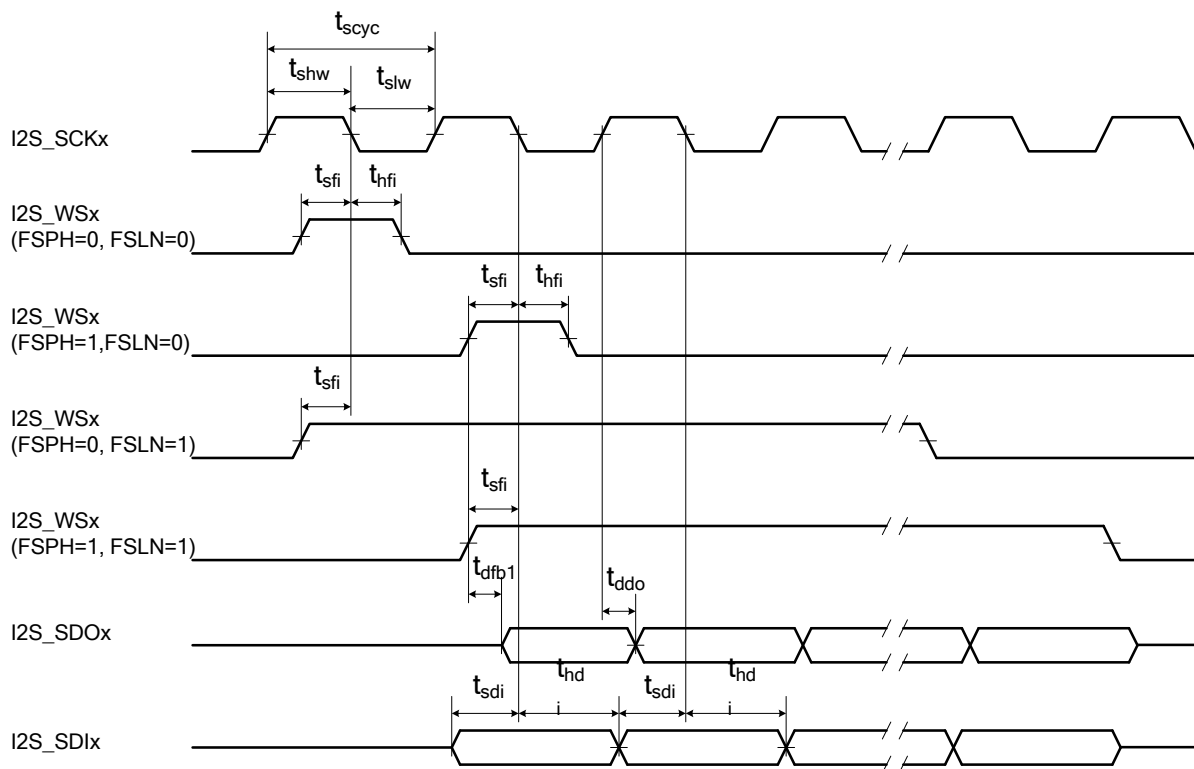

**Figure 8-25 Slave Mode Timing**



### 8.5.8. UART Signal Timing

**Table 8-36 AC Timing**

Signal	Symbol	Description	Value			Unit
			Min.	Typ.	Max.	
UART_SOUT0 UART_SOUT1 UART_SOUT2 UART_SOUT3 UART_SOUT4 UART_SOUT5	$t_{do}$	Data output delay time	–	–	12	ns
UART_SIN0 UART_SIN1 UART_SIN2 UART_SIN3 UART_SIN4 UART_SIN5	$t_{dw}$	Input data width	16*A	–	–	ns
UART_XRTS0	$t_{rtso}$	XRTS output delay time	–	–	11	ns
UART_XCTS0	$t_{ctsw}$	Input XCTS data width	A	–	–	ns

Internal clock is the standard of output delay.

A indicates APB bus clock cycle, and it is different from the output delay standard clock.

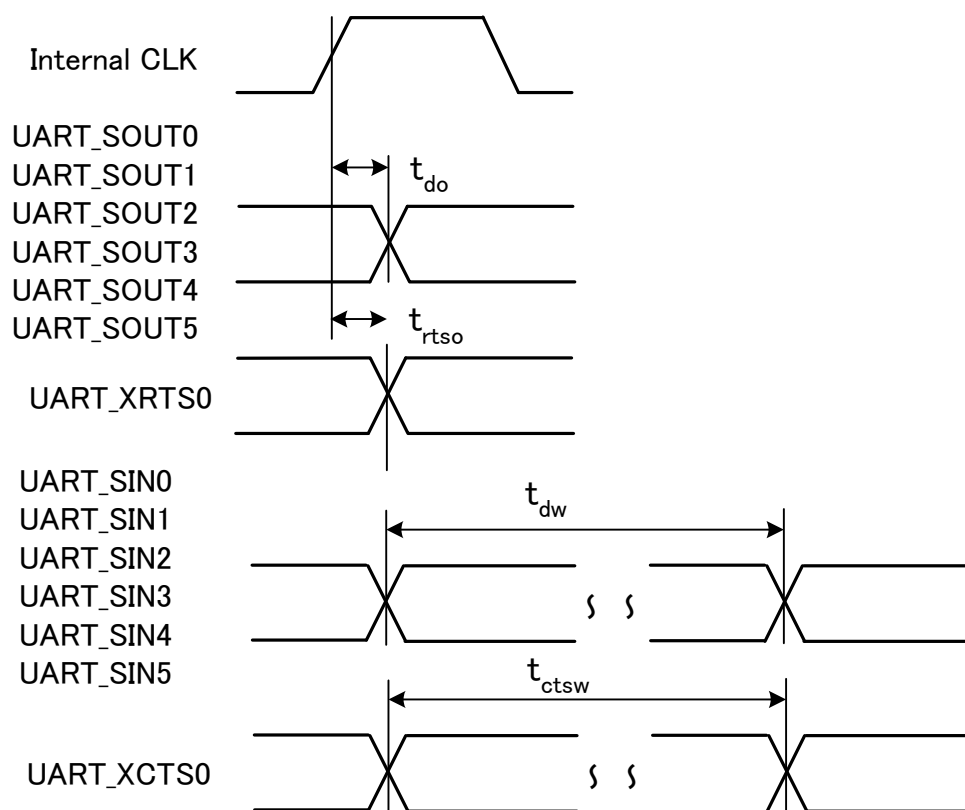

**Figure 8-26 UART Timing**

### 8.5.9. I<sup>2</sup>C Bus Timing

Table 8-37 AC timing of I<sup>2</sup>C signal

Signal	Symbol	Description	Value			Unit	
			Min.	Typ.	Max.		
I2C_SDA0 I2C_SDA1	T <sub>S2SDAI</sub>	SDAI setup time	Normal mode	250 (*1)	–	–	ns
			High-speed mode	100 (*1)	–	–	ns
	T <sub>H2SDAI</sub>	SDAI hold time	Normal mode	0.0 (*1)	–	–	ns
			High-speed mode	0.0 (*1)	–	–	ns
	T <sub>WBF1</sub>	BUS free time	Normal mode	4.7 (*1)	–	–	μs
			High-speed mode	1.3 (*1)	–	–	μs
I2C_SCL0 I2C_SCL1	T <sub>CSCLI</sub>	SCLI cycle time	Normal mode	1.0 (*1)	–	–	μs
			High-speed mode	2.5 (*1)	–	–	μs
	T <sub>WHSCLI</sub>	SCLI H width	Normal mode	4.0 (*1)	–	–	μs
			High-speed mode	0.6 (*1)	–	–	μs
	T <sub>WLSCLI</sub>	SCLI L width	Normal mode	4.7 (*1)	–	–	μs
			High-speed mode	1.3 (*1)	–	–	μs
	T <sub>CSCLO</sub>	SCLO cycle time	Normal mode	2*m + 2 (*2)	–	–	PCLK (*3)
			High-speed mode	Int (1.5*m) + 2 (*2)	–	–	PCLK (*3)
	T <sub>WHSCLO</sub>	SCLO H width	Normal mode	m + 2 (*2)	–	–	PCLK (*3)
			High-speed mode	Int (0.5*m) + 2 (*2)	–	–	PCLK (*3)
	T <sub>WLSCLO</sub>	SCLO L width	Normal mode	m (*2)	–	–	PCLK (*3)
			High-speed mode	m (*2)	–	–	PCLK (*3)
	T <sub>S2SCLI</sub>	SCLI setup time	Normal mode	4.0 (*2)	–	–	μs
			High-speed mode	0.6 (*2)	–	–	μs
T <sub>H2SCLI</sub>	SCLI hold time	Normal mode	4.7 (*2)	–	–	μs	
		High-speed mode	1.3 (*2)	–	–	μs	

\*1: I<sup>2</sup>C bus specification value

\*2: See I<sup>2</sup>C bus interface's clock control register (I2CxCCR) of the MB86R01 LSI product specifications for the "m" value

\*3: PCLK = APB bus clock cycle

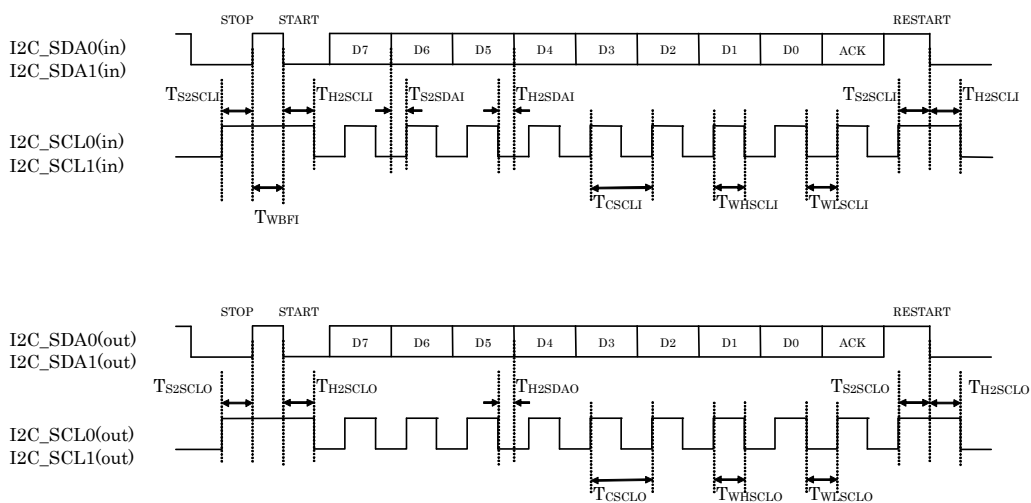

Figure 8-27 I<sup>2</sup>C Access Timing

### 8.5.10. SPI Signal Timing

**Table 8-38 SPIAC Timing**

Signal	Symbol	Description	Value			Unit
			Min.	Typ.	Max.	
SPI_SCK	$t_{cyc}$	Operating frequency	–	–	$0.5 \cdot A$	MHz
SPI_DI	$t_{sdi}$	Setup time, SPI_DI valid before SPI_SCK	15	–	–	ns
	$t_{hdi}$	Hold time, SPI_DI valid after SPI_SCK	15	–	–	ns
SPI_DO	$t_{do}$	Delay time, SPI_SCK	-2	–	5	ns
SPI_SS	$t_{sso}$	Delay time, SPI_SCK	-2	–	5	ns

A indicates APB bus clock frequency.

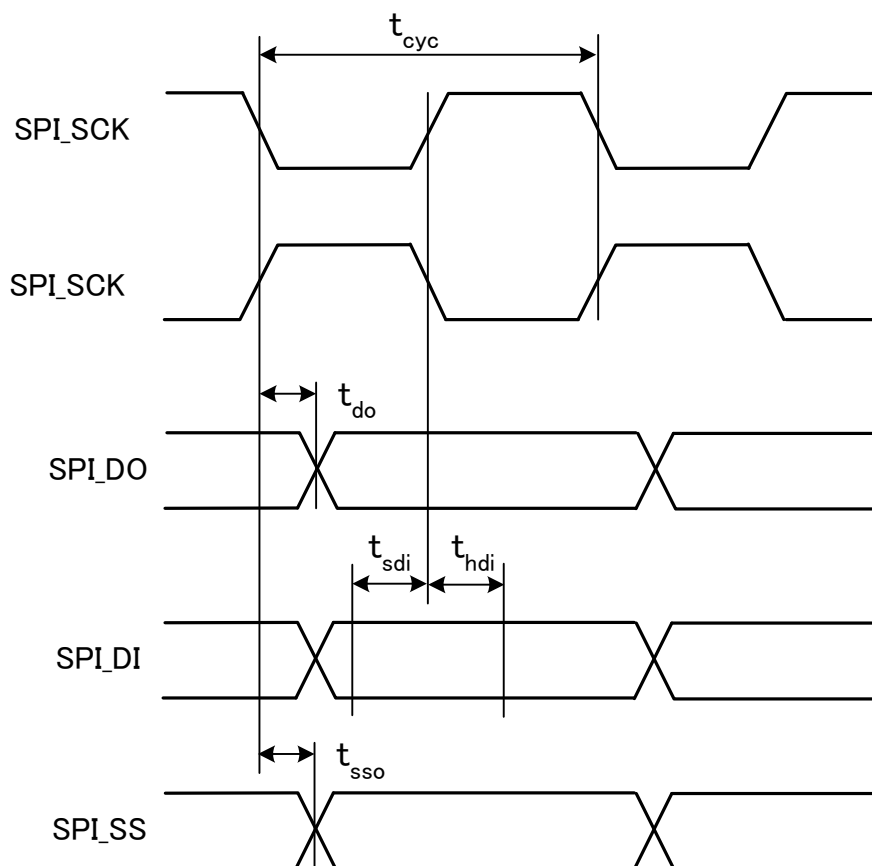

**Figure 8-28 SPI Timing**

Polarity of SPI\_SCK is determined by the register setting.

### 8.5.11. CAN Signal Timing

**Table 8-39 CAN AC Timing**

Signal	Symbol	Description	Value			Unit
			Min.	Typ.	Max.	
CAN_TX0 CAN_TX1	$t_{do}$	Data output delay time	-	-	17	ns
CAN_RX0 CAN_RX1	$t_{dw}$	Input data width	1000	-	-	ns

Internal clock is the standard of output delay.

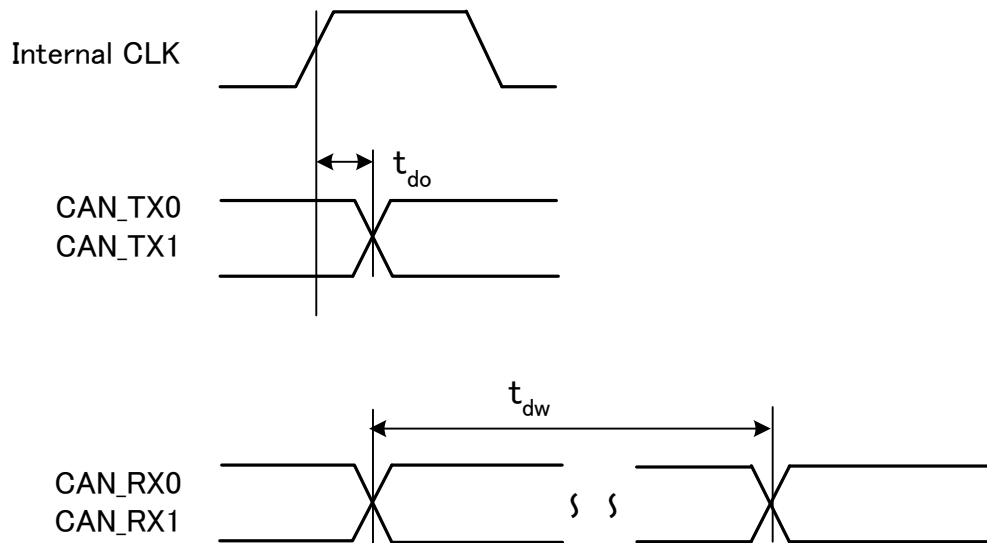

**Figure 8-29 CAN Timing**

## 8.5.12. MediaLB Signal Timing

### 8.5.12.1. MediaLB AC Spec Type A

Ground = 0V; Load capacitance = 60pF; MediaLB speed = 256Fs or 512Fs; Fs = 48kHz; all timing parameters specified from the valid voltage threshold as listed below; unless otherwise noted.

#### 8.5.12.1.1. Clock

**Table 8-40 AC Timing of Clock Signal**

Signal	Symbol	Description	Value			Unit	Comment
			Min.	Typ.	Max.		
MLBCLK	$f_{mck}$	MLBCLK operating frequency (*1)	11.264 – –	– 22.5792 –	– – 24.6272	MHz	256xFs at 44.0kHz 512xFs at 44.1kHz 512xFs at 48.1kHz
	$t_{mckr}$	MLBCLK rising time	–	–	3	ns	$V_{IL}$ to $V_{IH}$
	$t_{mckf}$	MLBCLK falling time	–	–	3	ns	$V_{IH}$ to $V_{IL}$
	$t_{mcke}$	MLBCLK cycle time	– –	81 40	– –	ns	256xFs 512xFs
	$t_{mckl}$	MLBCLK low time	30 14	37 17	– –	ns	256xFs 512xFs
	$t_{mckh}$	MLBCLK high time	30 14	38 17	– –	ns	256xFs 512xFs
	$t_{mpvw}$	MLBCLK pulse width variation	–	–	2	ns pp	(*2)

\*1: The controller can shut off MLBCLK to place MediaLB in a low-power state.

\*2: Pulse width variation is measured at 1.25V by triggering on one edge of MLBCLK and measuring the spread on the other edge, measured in ns peak-to-peak (pp).

#### 8.5.12.1.2. Input Signal

**Table 8-41 AC Timing of Input Signal**

Signal	Symbol	Description	Value			Unit	Comment
			Min.	Typ.	Max.		
MLBSIG, MLBDAT input	$t_{dsmcf}$	MLBSIG and MLBDAT input valid to MLBCLK falling	4	–	–	ns	
	$t_{dhmcf}$	MLBSIG and MLBDAT input hold from MLBCLK low	0	–	–	ns	

#### 8.5.12.1.3. Output Signal

**Table 8-42 AC Timing of Output Signal**

Signal	Symbol	Description	Value			Unit	Comment
			Min.	Typ.	Max.		
MLBSIG, MLBDAT output	$t_{mcfdz}$	MLBSIG and MLBDAT output high impedance from MLBCLK low	0	–	$t_{mckl}$	ns	
	$t_{mdzh}$	Bus hold time	4	–	–	ns	(*1)

\*1: The board must be designed to ensure that the high-impedance bus does not leave the logic state of the final driven bit for this time period. Therefore, coupling must be minimized while meeting the maximum capacitive load listed.

### 8.5.12.2. MediaLB AC Spec Type B

Ground = 0V, Load capacitance = 40pF, MediaLB speed = 1024Fs, and Fs = 48kHz.

All timing parameters are specified from the valid voltage threshold as listed below; unless otherwise noted.

#### 8.5.12.2.1. Clock

**Table 8-43 AC Timing of Clock Signal**

Signal	Symbol	Description	Value			Unit	Comment	
			Min.	Typ.	Max.			
MLBCLK	$f_{mck}$	MLBCLK operating frequency (*1)	45.056 – –	– 49.152 –	– – 49.2544	MHz	1024xFs at 44.0kHz 1024xFs at 48.0kHz 1024xFs at 48.1kHz	
	$t_{mckr}$	MLBCLK rising time	–	–	1		ns	$V_{IL}$ to $V_{IH}$
	$t_{mckf}$	MLBCLK falling time	–	–	1		ns	$V_{IH}$ to $V_{IL}$
	$t_{mckc}$	MLBCLK cycle time	–	20.3	–	ns		
	$t_{mckl}$	MLBCLK low time	6.8	7.8	–	ns		
	$t_{mckh}$	MLBCLK high time	9.7	10.4	–	ns		
	$t_{mpwv}$	MLBCLK pulse width variation	–	–	0.5	ns pp	(*2)	

\*1: The controller can shut off MLBCLK to place MediaLB in a low-power state.

\*2: Pulse width variation is measured at 1.25V by triggering on one edge of MLBCLK and measuring the spread on the other edge, measured in ns peak-to-peak (pp).

#### 8.5.12.2.2. Input Signal

**Table 8-44 AC Timing of Input Signal**

Signal Name	Symbol	Description	Value			Unit	Comment
			Min.	Typ.	Max.		
MLBSIG, MLBDAT input	$t_{dsmcf}$	MLBSIG and MLBDAT input valid to MLBCLK falling	1	–	–	ns	
	$t_{dhmcf}$	MLBSIG and MLBDAT input hold from MLBCLK low	0	–	–	ns	

#### 8.5.12.2.3. Output signal

**Table 8-45 AC Timing of Output Signal**

Signal Name	Symbol	Description	Value			Unit	Comment
			Min.	Typ.	Max.		
MLBSIG, MLBDAT Output	$t_{mcfdz}$	MLBSIG and MLBDAT output high impedance from MLBCLK low	0	–	$t_{mckl}$	ns	
	$t_{mdzh}$	Bus hold time	2	–	–	ns	(*1)

\*1: The board must be designed to ensure that the high-impedance bus does not leave the logic state of the final driven bit for this time period. Therefore, coupling must be minimized while meeting the maximum capacitive load listed.

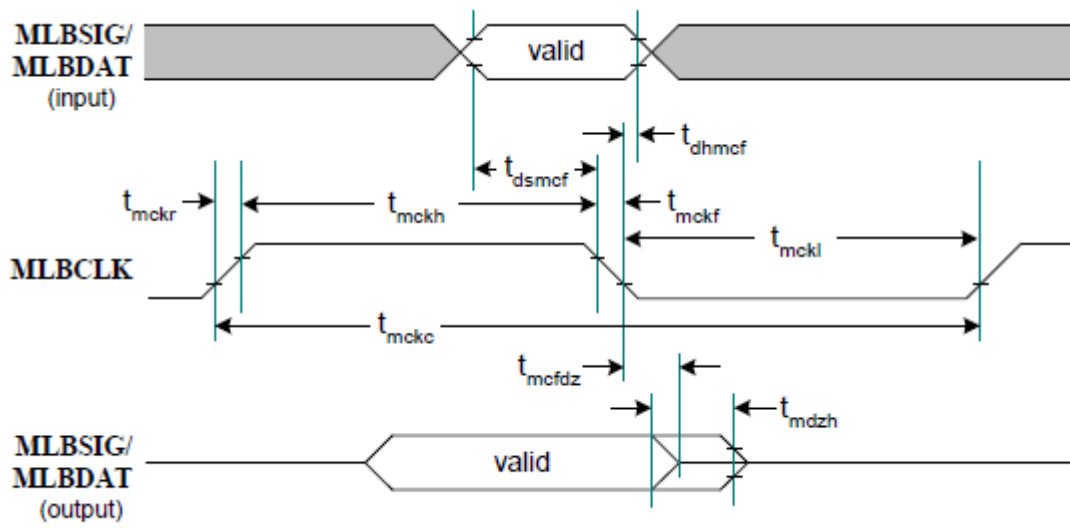

Figure 8-30 MediaLB Timing

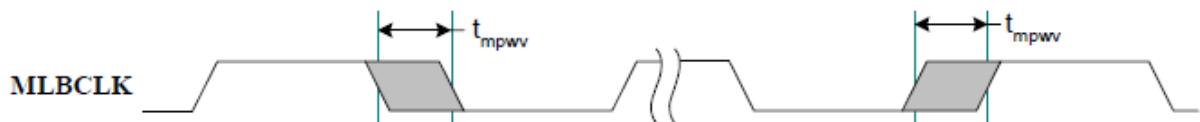

Figure 8-31 MediaLB Pulse Width Variation Timing

### 8.5.13. USB2.0 Signal Timing

**Table 8-46 High-speed AC Timing**

Signal	Symbol	Description	Value			Unit
			Min.	Typ.	Max.	
USB_HSDP USB_HSDM USB_FSDP USB_FSDM	Driver characteristics:					
	t <sub>hsr</sub>	Rise time (10% - 90%)	500	–	–	ps
	t <sub>hsf</sub>	Fall time (10% - 90%)	500	–	–	ps
	–	Driver waveform requirements	Complying with USB2.0 specification (section 7.1.2)			
	zhdrv	Driver output resistance (which also serves as high-speed termination)	40.5	–	49.5	Ω
	Clock timing:					
	thsdrat	High-speed data rate	479.760	–	480.240	Mb/s
	High-speed data timing:					
	–	Data source jitter	Complying with USB2.0 specification (section 7.1.2)			
	–	Receiver jitter tolerance	Complying with USB2.0 specification (section 7.1.2)			

**Table 8-47 Full-speed AC Timing**

Signal	Symbol	Description	Value			Unit
			Min.	Typ.	Max.	
USB_HSDP USB_HSDM USB_FSDP USB_FSDM	Driver characteristics:					
	t <sub>fr</sub>	Rise time (10% - 90%)	4	–	20	ns
	t <sub>ff</sub>	Fall time (10% - 90%)	4	–	20	ns
	t <sub>frfm</sub>	Difference rise and fall time matching	90	–	111.11	%
	Clock timing: (in case of using UTMI i/f and setting FSSEL = "0")					
	t <sub>fdraths</sub>	Full-speed data rate for hubs and devices which are capable of high-speed	11.9940	–	12.0060	Mb/s
	Full-speed data timings: (in case of using UTMI i/f and setting FSSEL = "0")					
	t <sub>dj1</sub>	Source jitter total (including frequency tolerance): To next transition For paired transitions	-3.5	–	3.5	ns
	t <sub>dj2</sub>		-4	–	4	
	t <sub>fdeop</sub>	Source jitter for differential transition to SE0 transition	-2	–	5	ns
	t <sub>jr1</sub>	Receiver jitter: To next transition For paired transitions	-18.5	–	18.5	ns
	t <sub>jr2</sub>		-9	–	9	
	t <sub>feopt</sub>	Source SE0 interval of EOP	160	–	175	ns
	t <sub>feopr</sub>	Receiver SE0 interval of EOP	82	–	–	ns
	t <sub>fst</sub>	Width of SE0 interval during differential transition	–	–	14	ns

**Table 8-48 Low-speed AC Timing**

Signal	Symbol	Description	Value			Unit
			Min.	Typ.	Max.	
USB_HSDP USB_HSDM USB_FSDP USB_FSDM	Driver characteristics:					
	t <sub>lr</sub>	Rise time (10% - 90%)	75	–	300	ns
	t <sub>lf</sub>	Fall time (10% - 90%)	75	–	300	ns
	t <sub>lrffm</sub>	Rise and fall time matching	80	–	125	%



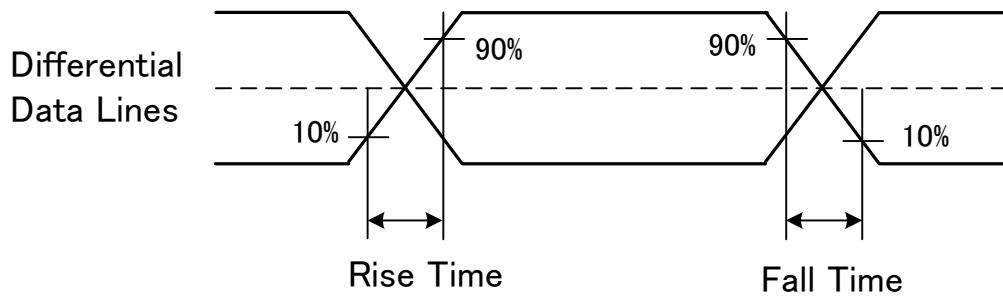

Figure 8-32 Data Signal Rise and Fall Time

## 8.5.14. IDE66 Signal Timing

### 8.5.14.1. IDE PIO Timing

**Table 8-49 AC timing of Register Access**

Symbol	Description	Value					Unit
		mode0	mode1	mode2	mode3	mode4	
t0	Cycle time (min.)	600	383	330	180	120	ns
t1	Address valid to IDE_XDIOR/IDE_XDIOW setup (min.)	70	50	30	30	25	ns
t2	IDE_XDIOR/IDE_XDIOW pulse width 8 bit (min.)	290	290	290	80	70	ns
t2i	IDE_XDIOR/IDE_XDIOW recovery time (min.)	–	–	–	70	25	ns
t3	IDE_XDIOW data setup (min.)	60	45	30	30	20	ns
t4	IDE_XDIOW data hold (min.)	30	20	15	10	10	ns
t5	IDE_XDIOR data setup (min.)	50	35	20	20	20	ns
t6	IDE_XDIOR data hold (min.)	5	5	5	5	5	ns
t6Z	IDE_XDIOR data tristate (max.)	30	30	30	30	30	ns
t9	IDE_XDIOR/IDE_XDIOW to address valid hold (min.)	20	15	10	10	10	ns
tRD	Read data valid to IDE_DIORDY active (if IDE_DIORDY initially low after tA) (min.)	0	0	0	0	0	ns
tA	IDE_DIORDY setup time	35	35	35	35	35	ns
tB	IDE_DIORDY pulse width (max.)	1250	1250	1250	1250	1250	ns
tC	IDE_DIORDY assertion to release (max.)	5	5	5	5	5	ns

**Table 8-50 AC timing of Data Access**

Symbol	Description	Value					Unit
		mode0	mode1	mode2	mode3	mode4	
t0	Cycle time (min.)	600	383	240	180	120	ns
t1	Address valid to IDE_XDIOR/IDE_XDIOW setup (min.)	70	50	30	30	25	ns
t2	IDE_XDIOR/IDE_XDIOW pulse width 8 bit (min.)	165	125	100	80	70	ns
t2i	IDE_XDIOR/IDE_XDIOW recovery time (min.)	–	–	–	70	25	ns
t3	IDE_XDIOW data setup (min.)	60	45	30	30	20	ns
t4	IDE_XDIOW data hold (min.)	30	20	15	10	10	ns
t5	IDE_XDIOR data setup (min.)	50	35	20	20	20	ns
t6	IDE_XDIOR data hold (min.)	5	5	5	5	5	ns
t6Z	IDE_XDIOR data tristate (max.)	30	30	30	30	30	ns
t9	IDE_XDIOR/IDE_XDIOW to address valid hold (min.)	20	15	10	10	10	ns
tRD	Read data valid to IDE_DIORDY active (if IDE_DIORDY initially low after tA) (min.)	0	0	0	0	0	ns
tA	IDE_DIORDY setup time	35	35	35	35	35	ns
tB	IDE_DIORDY pulse width (max.)	1250	1250	1250	1250	1250	ns
tC	IDE_DIORDY assertion to release (max.)	5	5	5	5	5	ns

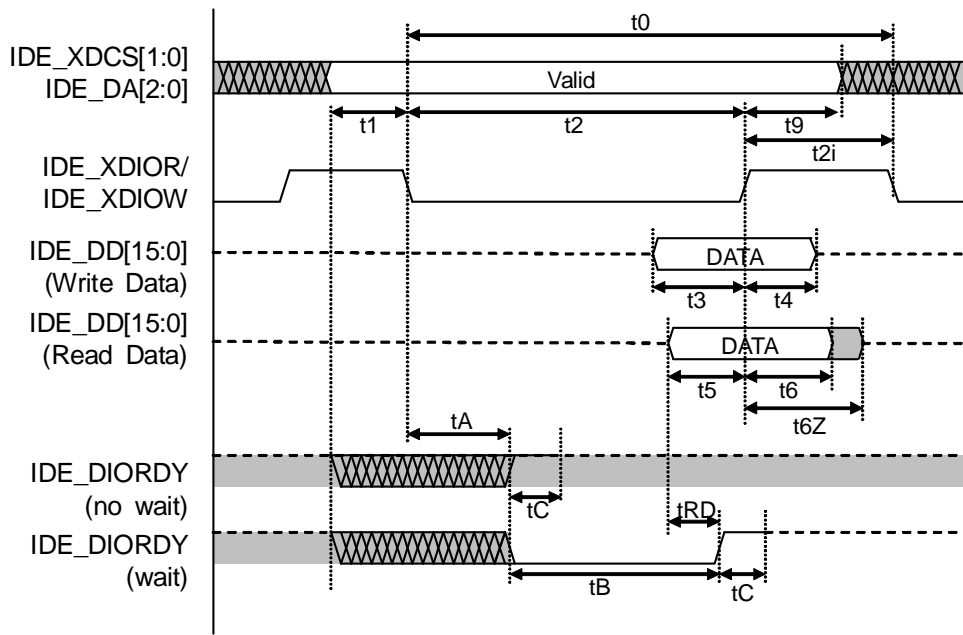

Figure 8-33 PIO Access Timing

### 8.5.14.2. IDE Ultra DMA Timing

Table 8-51 AC timing of Ultra DMA

Symbol	Description	Value										Unit
		mode0		mode1		mode2		mode3		mode4		
		Min.	Max.	Min.	Max.	Min.	Max.	Min.	Max.	Min.	Max.	
T2cycleTYP	Typical sustained average 2 cycle time	240	–	160	–	120	–	90	–	60	–	ns
T2cycle	2 cycle time allowing for clock variations (from rising edge to next rising edge or from falling edge to next falling edge of STROBE)	230	–	154	–	115	–	86	–	57	–	ns
Tcycle	Cycle time allowing for asymmetry and clock variations (from STROBE edge to STROBE edge)	112	–	73	–	54	–	39	–	25	–	ns
Tdvs	Data valid setup time at sender (from data valid until STROBE edge)	70	–	48	–	30	–	20	–	6.7	–	ns
Tdvh	Data valid setup time at sender (from STROBE edge until data may become invalid)	6.2	–	6.2	–	6.2	–	6.2	–	6.2	–	ns
Tfs	First STROBE time (for device to first negatedSTROBE from STOP during data in Burst)	–	230	–	200	–	170	–	130	–	120	ns
Tli	Limited interlock time	0	150	0	150	0	150	0	100	0	100	ns
Tmli	Interlock time with minimum	20	–	20	–	20	–	20	–	20	–	ns
Tui	Unlimited interlock time	0	–	0	–	0	–	0	–	0	–	ns
Taz	Maximum time allowed for output drivers to release (from asserted or negated)	–	10	–	10	–	10	–	10	–	10	ns
Tzah	Minimum delay time required for output	20	–	20	–	20	–	20	–	20	–	ns
Tzad	Drivers to assert or negate (from released)	0	–	0	–	0	–	0	–	0	–	ns
Tenv	Envelope time (from DMACK- to STOP and HDMARDY- during data in burst initiation and from IDE_XDDDMACK to STOP during data out burst initiation)	20	70	20	70	20	70	20	55	20	55	ns
Trfs	Ready-to-final-STROBE time (no STROBE edges shall be sent this long after negation of DMARDY)	–	75	–	70	–	60	–	60	–	60	ns
Trp	Minimum time to assert STOP or negate IDE_DMARQ	160	–	125	–	100	–	100	–	100	–	ns
Tiordyz	Maximum time before releasing IDE_DIORDY	–	20	–	20	–	20	–	20	–	20	ns
tziordy	Minimum time before driving STROBE	0	–	0	–	0	–	0	–	0	–	ns
Tack	Setup and hold times for DMACK- (before assertion or negation)	20	–	20	–	20	–	20	–	20	–	ns
Tss	Time from STROBE edge to negation of DMARQ or assertion of STOP (when sender terminates burst)	50	–	50	–	50	–	50	–	50	–	ns

<Ultra DMA Read Access>

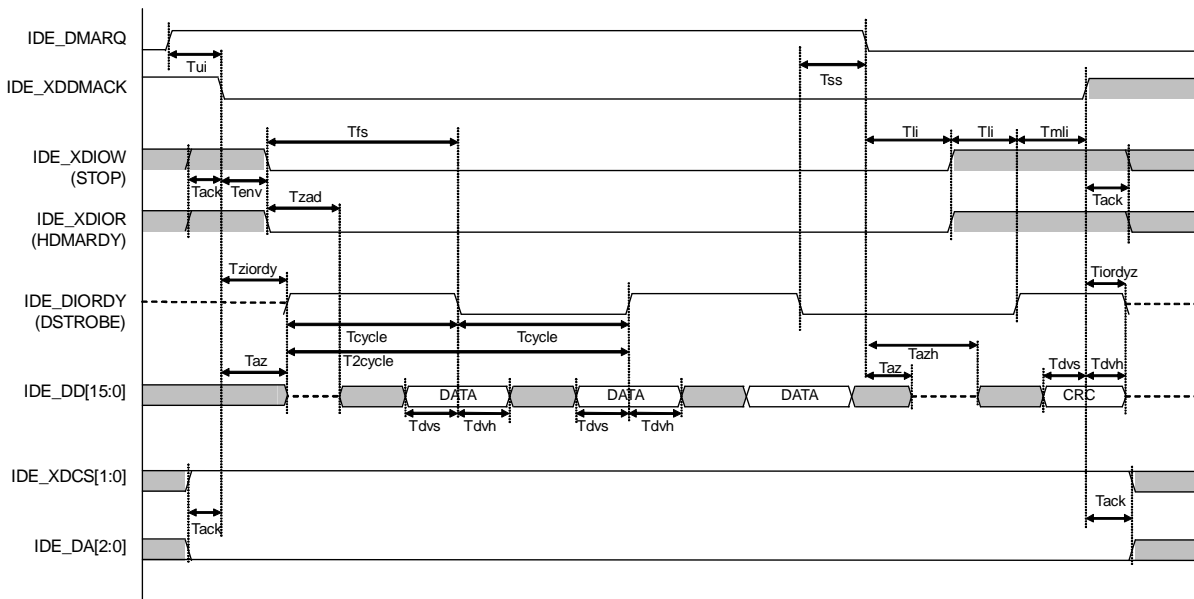

Figure 8-34 IDE Read Access Timing

<Ultra DMA Write Access>

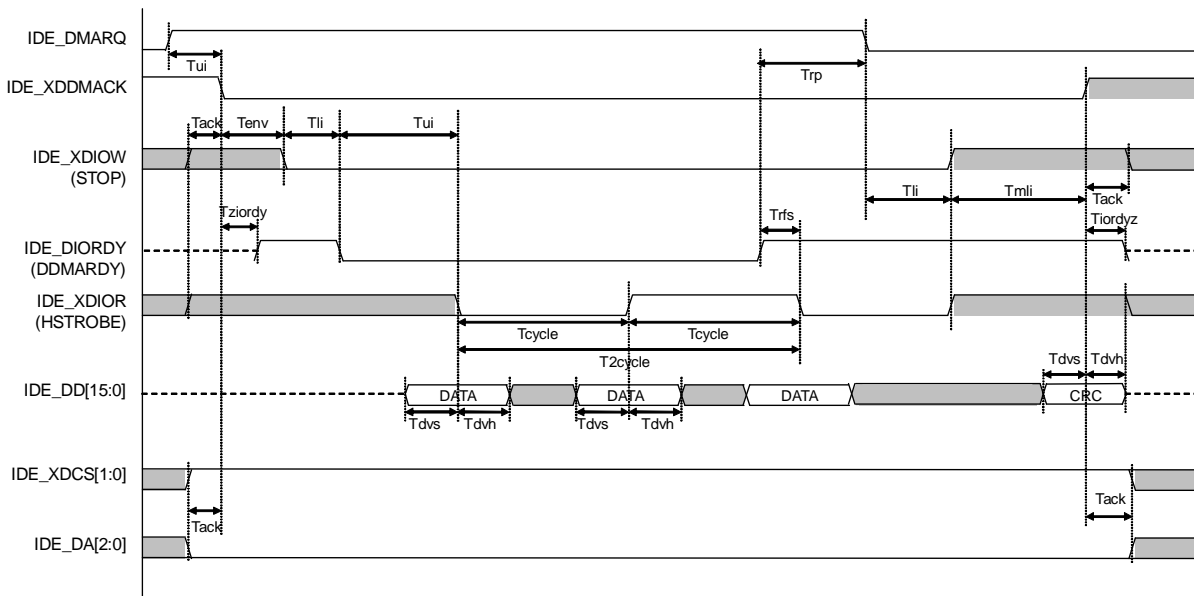

Figure 8-35 IDE Write Access Timing

## 8.5.15. SD Signal Timing

### 8.5.15.1. Clock

Table 8-52 AC Timing of Clock Signal

Signal Name	Symbol	Description	Value			Unit
			Min.	Typ.	Max.	
SD_CLK	t_CLK	SD_CLK cycle	–	–	20.83 (*1)	MHz

\*1: 20.83MHz for SD memory card and 20MHz for multimedia card (MMC)

### 8.5.15.2. Input/Output Signal

Table 8-53 AC Timing of Data Signal

Signal Name	Symbol	Description	Value			Unit
			Min.	Typ.	Max.	
SD_DAT[3:0]	tD_DAT	Output data delay (standard of SD_CLK falling edge)	-6.0	–	3.0	ns
	tS_DAT	Input data setup (standard of SD_CLK rising edge)	13.0	–	–	ns
	tH_DAT	Input data hold (standard of SD_CLK rising edge)	19.0	–	–	ns

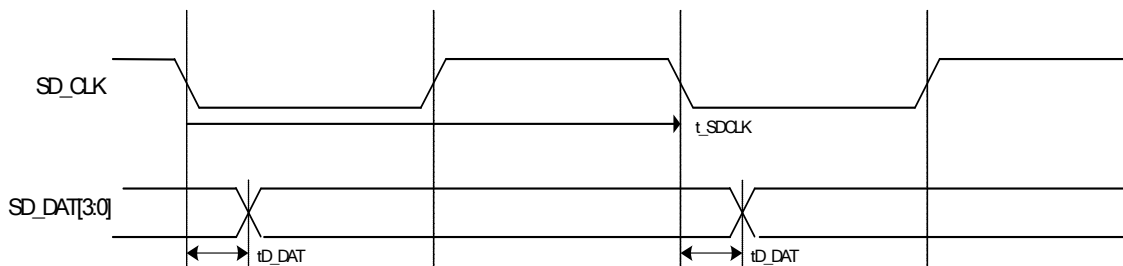

Figure 8-36 Output Timing to Media

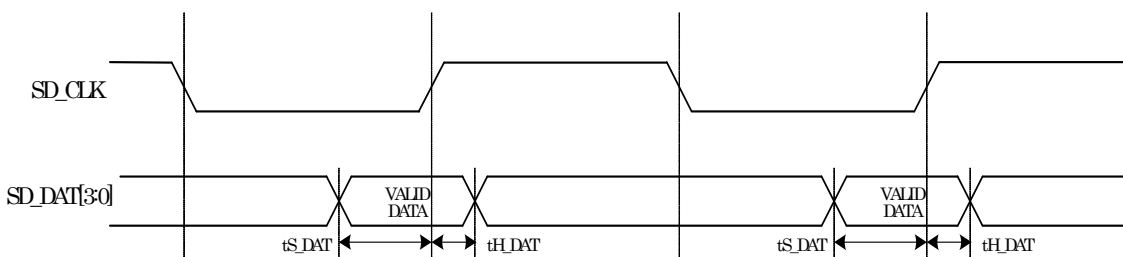
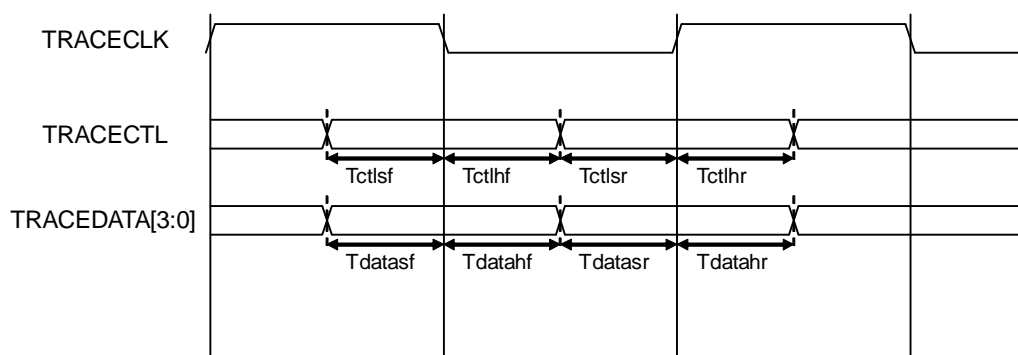

Figure 8-37 Input Timing from Media

### 8.5.16. ETM9 Trace Port Signal Timing

**Table 8-54 AC Timing of Trace Signal**

Signal Name	Symbol	Description	Value			Unit
			Min.	Typ.	Max.	
TRACECTL	Tctlsr	TRACECTL setup time to rising edge of TRACECLK.	2	–	–	ns
	Tctlhr	TRACECTL hold time to rising edge of TRACECLK.	1	–	–	ns
	Tctlsf	TRACECTL setup time to falling edge of TRACECLK.	2	–	–	ns
	Tctlhf	TRACECTL hold time to falling edge of TRACECLK.	1	–	–	ns
TRACEDATA[3:0]	Tdatasr	TRACEDATA setup time to rising edge of TRACECLK.	2	–	–	ns
	Tdatahr	TRACEDATA hold time to rising edge of TRACECLK.	1	–	–	ns
	Tdatasf	TRACEDATA setup time to falling edge of TRACECLK.	2	–	–	ns
	Tdatahf	TRACEDATA hold time to falling edge of TRACECLK.	1	–	–	ns



[NOTE] MB86R01 supports only half-rate clocking mode.

**Figure 8-38 Trace Signal Timing**

### 8.5.17. EXIRC Signal Timing

**Table 8-55 AC Timing**

Signal Name	Symbol	Description	Value			Unit
			Min.	Typ.	Max.	
INT_A[3:0]	$t_{dw}$	Input data-width	A	–	–	ns

The case that external interrupt input request is edge (rising edge and falling edge), input data width ( $t_{dw}$ ) is regulated as follows. When level ("H" or "L") is selected as the request, it should be held until interrupt process is completed. A indicates APB bus clock cycle.

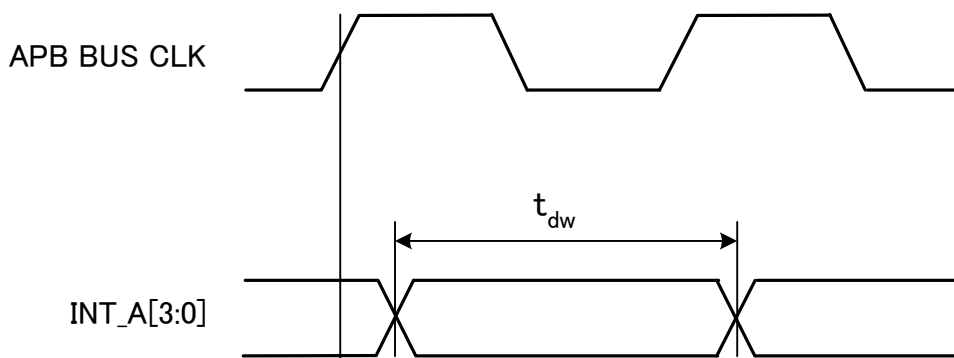

**Figure 8-39 EXIRC Timing**



  
**FUJITSU**

## X-ON Electronics

Largest Supplier of Electrical and Electronic Components

*Click to view similar products for [Fujitsu manufacturer](#):*

Other Similar products are found below :

[FCN-363J008](#) [MAT4Z-DR](#) [FCN-268M024-G/1D](#) [FTP-639USL202](#) [FTR-K3AB012W](#) [PZ-2A2415](#) [PZ-2A2425](#) [PZ-2A2430](#) [PZ-2A2445](#) [PZ-4A2620](#) [PZ-4A2650](#) [PZ-6A2805](#) [PZ-6A2810](#) [PZ-6A2830](#) [PZ-6A2840](#) [GZ-12C](#) [GZ-12W](#) [GZ-18H](#) [GZ-9H](#) [AL-24W-K](#) [DZ4E-12V](#) [ITT2B-EH](#) [ITT2-BR](#) [25A04C24C](#) [25A04C28C](#) [RY-48W-K](#) [RY-5WZ-K](#) [26A06C54E](#) [RZ-24C](#) [RZ-2G5](#) [RZ-48C](#) [RZ-5WC](#) [RZ-6](#) [RZ-6W](#) [FTP-622CT001](#) [FTR-K1CK012W-KW](#) [24A02C81E](#) [24A12C24C](#) [24A12C61E](#) [25A04C14E](#) [25A14C09C](#) [25A14C20C](#) [26A06C08C](#) [26A06C24C](#) [26A16C11E](#) [26A16C23F](#) [GZ-3](#) [PZ-2A2412](#) [PZ-2L1D](#) [PZ-6A2800](#)