

SPEC. No. ED 06P030
ISSUE June 8, 2006

SHARP

OPTO-ANALOG DEVICES DIVISION
ELECTRONIC COMPONENTS GROUP
SHARP CORPORATION

SPECIFICATION

DEVICE SPECIFICATION FOR

PHOTOTRIAC COUPLER

MODEL No. S2S3

Business dealing name

| | |
|--|----------|
| | S2S3A00F |
| | S2S3AY0F |

Specified for _____

Enclosed please find copies of the Specifications which consists of 14 pages including cover.
This specification sheets and attached sheets shall be both side copy.
After confirmation of the contents, please be sure to send back copies of the Specifications
with approving signature on each.

CUSTOMER'S APPROVAL

DATE _____

BY _____

PRESENTED

DATE _____

BY Id. O.

H. Imanaka,
Department General Manager of
Engineering Dept.,II
Opto-Analog Devices Div.
ELECOM Group
SHARP CORPORATION

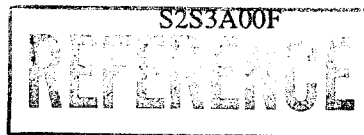

Product name : PHOTOTRIAC COUPLER

Model No. : S2S3

(Business dealing name : S2S3A00F)

(Business dealing name : S2S3AY0F)

1. These specification sheets include materials protected under copyright of Sharp Corporation ("Sharp"). Please do not reproduce or cause anyone to reproduce them without Sharp's consent.
2. When using this product, please observe the absolute maximum ratings and the instructions for use outlined in these specification sheets, as well as the precautions mentioned below. Sharp assumes no responsibility for any damage resulting from use of the product which does not comply with the absolute maximum ratings and the instructions included in these specification sheets, and the precautions mentioned below.

(Precautions)

- (1) This product is designed for use in the following application areas ;

[· OA equipment · Audio visual equipment · Home appliances
· Telecommunication equipment (Terminal) · Measuring equipment
· Tooling machines · Computers]

If the use of the product in the above application areas is for equipment listed in paragraphs (2) or (3), please be sure to observe the precautions given in those respective paragraphs.

- (2) Appropriate measures, such as fail-safe design and redundant design considering the safety design of the overall system and equipment, should be taken to ensure reliability and safety when this product is used for equipment which demands high reliability and safety in function and precision, such as ;

[· Transportation control and safety equipment (aircraft, train, automobile etc.)
· Traffic signals · Gas leakage sensor breakers · Rescue and security equipment
· Other safety equipment]

- (3) Please do not use this product for equipment which require extremely high reliability and safety in function and precision, such as ;

[· Space equipment · Telecommunication equipment (for trunk lines)
· Nuclear power control equipment · Medical equipment]

- (4) Please contact and consult with a Sharp sales representative if there are any questions regarding interpretation of the above three paragraphs.

3. Please contact and consult with a Sharp sales representative for any questions about this product.

1. Application

This specification applies to the outline and characteristics of phototriac coupler Model No. S2S3 (Apply line voltage 200V AC).

2. Outline

Refer to the attached sheet, page 4.

3. Ratings and characteristics

Refer to the attached sheet, page 5, 6.

4. Reliability

Refer to the attached sheet, page 7.

5. Outgoing inspection

Refer to the attached sheet, page 8.

6. Supplement

6.1 Business dealing name

("○" mark indicates business dealing name of ordered product)

| Product | Business dealing name | Remarks |
|---------|-----------------------|--|
| | S2S3A00F | |
| | S2S3AY0F | * Applied to products as an option (Attachment-1-1 to 1-3) |

6.2 Package specification

Refer to the attached sheet, page 9,10.

6.3 Isolation voltage shall be measured in the following method.

- (1) Short between pins 1 to 2 on the primary side and between pins 3 to 4 on the secondary side.
- (2) The dielectric withstanding tester with zero-cross circuit shall be used.
- (3) The wave form of applied voltage shall be a sine wave.

(It is recommended that the isolation voltage be measured in insulation oil.)

6.4 This Model is approved by UL, CSA.

Approved Model No. : S2S3

UL file No. : E64380

CSA file No. : CA95323

CSA approved mark “  ” shall be indicated on minimum unit package.

6.5 This product is not designed against irradiation.

This product is assembled with electrical input and output.

This product incorporates non-coherent light emitting diode.

6.6 ODS materials

This product shall not contain the following materials.

Also, the following materials shall not be used in the production process for this product.

Materials for ODS : CFC_s, Halon, Carbon tetrachloride, 1,1,1-Trichloroethane (Methyl chloroform)

6.7 Brominated flame retardants

Specific brominated flame retardants such as the PBBO_s and PBB_s are not used in this device at all.

7. Notes

7.1 Circuit design

- (1) The LED used in the Phototriac coupler generally decreases the light emission power by operation.
 In case of long operation time, please decide I_F value so that I_F is more than 2 times of the Maximum value of the Minimum triggering current at circuit design with considering the decreases of the light emission power of the LED. (50%/5years)
- (2) Input current (I_F) at off state shall be set 0.1mA or less.
- (3) In case that pulse drive is carried out, it shall be recommended to use that the pulse width of input signal is 1ms or more.

7.2 Usage

Please, use only for triggering medium and high power triac.
 (This model shall be used under the conditions on which power triac turns on.)

7.3 Cleaning

- (1) Solvent cleaning : Solvent temperature 45°C or less, Immersion for 3 min or less
- (2) Ultrasonic cleaning : The effect to device by ultrasonic cleaning differs
 by cleaning bath size, ultrasonic power
 output, cleaning time, PCB size or device mounting condition etc.
 Please test it in actual using condition
 and confirm that any defect doesn't occur before starting the ultrasonic cleaning.
- (3) Applicable solvent : Ethyl alcohol, Methyl alcohol, Isopropyl alcohol
 When the other solvent is used, there are cases that the packaging resin is eroded.
 Please use the other solvent after thorough confirmation is performed in actual using condition.

7.4 Precautions for Soldering Phototriac couplers

- (1) In the case of flow soldering (Whole dipping is possible.)
 It is recommended that flow soldering be carried out at 260°C or less
 and within 10s (Pre-heating : 100 to 150°C, 30 to 80s): within 2 times
- (2) If solder reflow :
 It is recommended to be done at the temperature and the time within the temperature profile as shown
 in the figure below. (2 times or less)

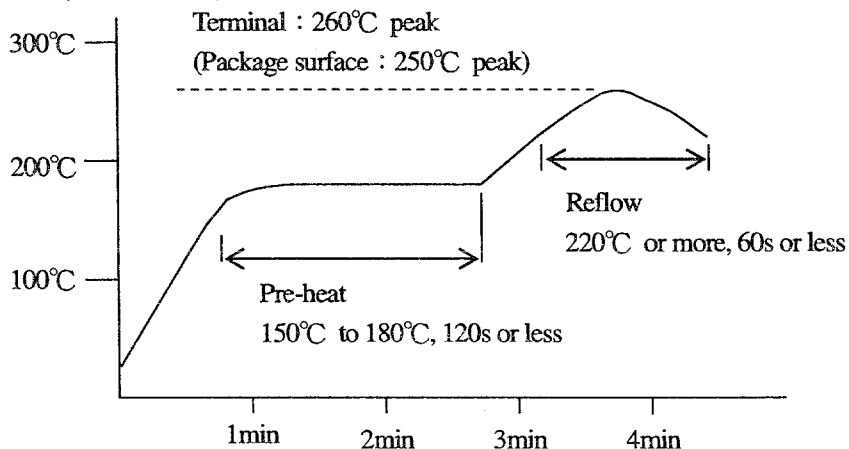

- (3) In the case of hand soldering
 It is recommended that hand soldering be carried out at 400°C or less and within 3s : Within 2 times
- (4) Other notes
 Depending on equipment and soldering conditions (temperature, Using solder etc.),
 the effect to junction between PCB and lead pins of photocoupler is different.
 Please confirm that there is no problem on the actual use conditions.

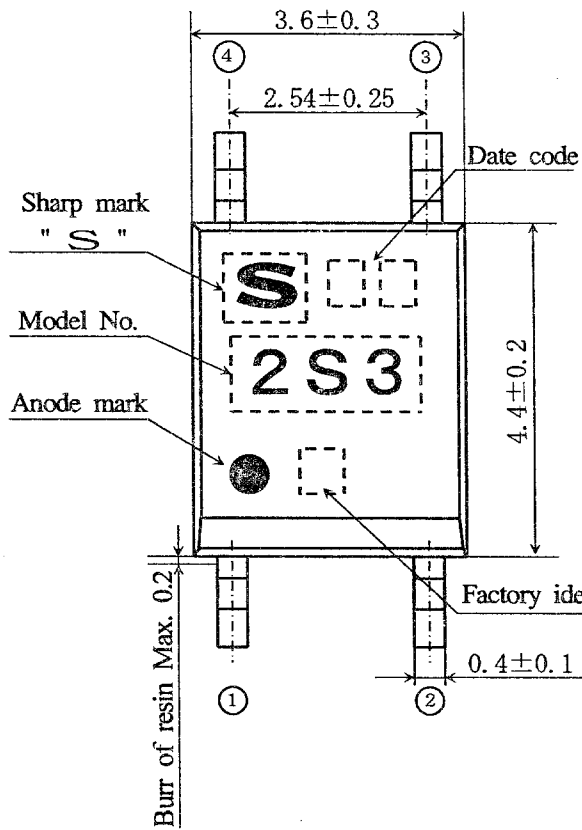
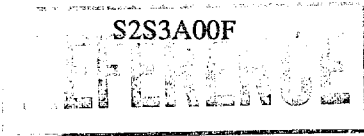

Pin-Number and internal connection diagram

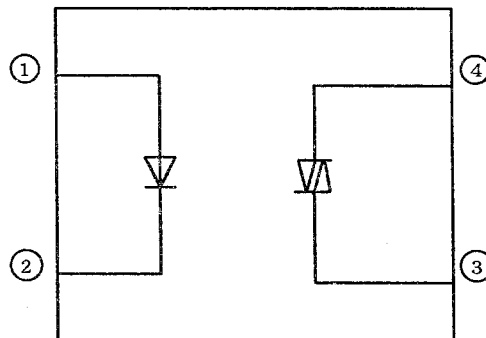

- ① Anode
- ② Cathode
- ③ Anode/ Cathode
- ④ Anode/ Cathode

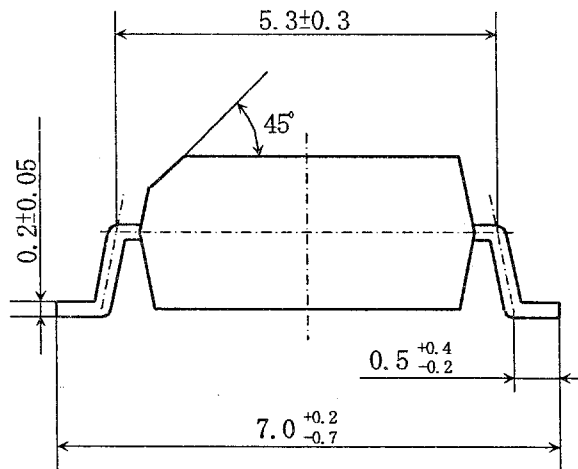
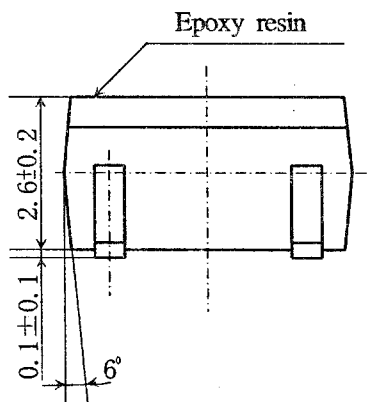

- *1) 2-digit number shall be marked according to OLD DIN standard.
- *2) Factory identification mark shall be or shall not be marked.
- *3) Marking is laser marking
- *4) Pin material : 42 Alloy
Pin finish : SnCu plating (Cu : TYP. 2%)

Product mass : Approx. 0.09g

UNIT : 1/1 mm

| | |
|------|---|
| Name | S2S3 Outline Dimensions (Business dealing name : S2S3A00F) |
|------|---|

3.1 Absolute maximum ratings

Ta=25°C

| Parameter | | Symbol | Rating | Unit |
|-----------------------|-----------------------------------|------------------------------|----------------------|------|
| Input | Forward current | I_F | 50 | mA |
| | Reverse voltage | V_R | 6 | V |
| Output | RMS on-state current *1 | $I_T(\text{rms})$ | 0.05 | A |
| | Peak one cycle surge current | I_{surge} | 0.6 (50Hz sine wave) | A |
| | Repetitive peak off-state voltage | V_{DRM} | 600 | V |
| Isolation voltage *2 | | $V_{\text{iso}}(\text{rms})$ | 3.75 | kV |
| Operating temperature | | T_{opr} | -30 to +100 | °C |
| Storage temperature | | T_{stg} | -40 to +125 | °C |
| Soldering temperature | | T_{sol} | 260 (For 10s) | °C |

*1 The definition for conductive angle of on-state current shall be in accordance with the below drawings.

For the derating curve, see Fig.1, 2.

*2 AC for 1min, 40 to 60%RH

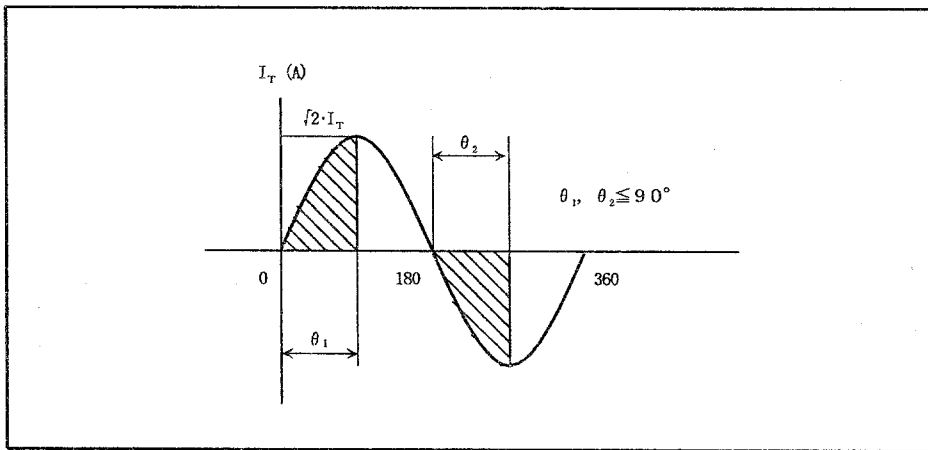

3.2 Electrical characteristics

Ta=25°C

| Parameter | | Symbol | MIN. | TYP. | MAX. | Unit | Conditions |
|--------------------------|--|------------------|--------------------|-----------|------|------------------------|--|
| Input | Forward voltage | V_F | - | 1.2 | 1.4 | V | $I_F=20\text{mA}$ |
| | Reverse current | I_R | - | - | 10 | μA | $V_R=3\text{V}$ |
| Output | Repetitive peak off-state current | I_{DRM} | - | - | 1 | μA | $V_D=V_{\text{DRM}}$ |
| | On-state voltage | V_T | - | - | 2.5 | V | $I_T=0.05\text{A}$ |
| | Holding current | I_H | 0.1 | - | 3.5 | mA | $V_D=6\text{V}$ |
| | Critical rate of rise of off-state voltage | dv/dt | 100 | 1000 | - | $\text{V}/\mu\text{s}$ | $V_D=1/\sqrt{2} \cdot V_{\text{DRM}}$ |
| Transfer characteristics | Minimum trigger current | I_{FT} | - | - | 10 | mA | $V_D=6\text{V}$ $R_L=100\Omega$ |
| | Isolation resistance | R_{ISO} | 5×10^{10} | 10^{11} | - | Ω | DC500V 40 to 60%RH |
| | Turn on time | t_{ON} | - | - | 100 | μs | $V_D=6\text{V}$, $R_L=100\Omega$, $I_F=20\text{mA}$ |

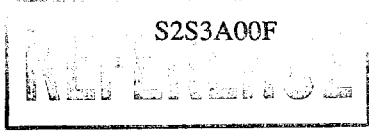

Fig.1 Forward current vs. ambient temperature

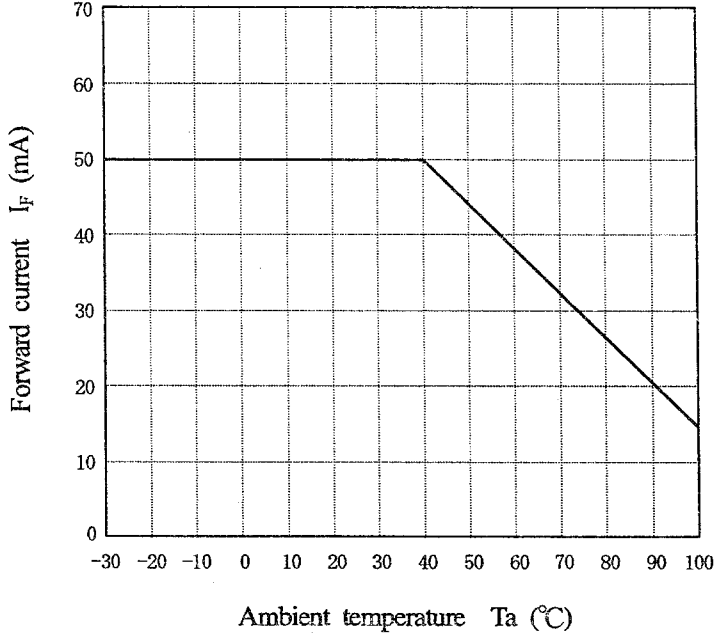
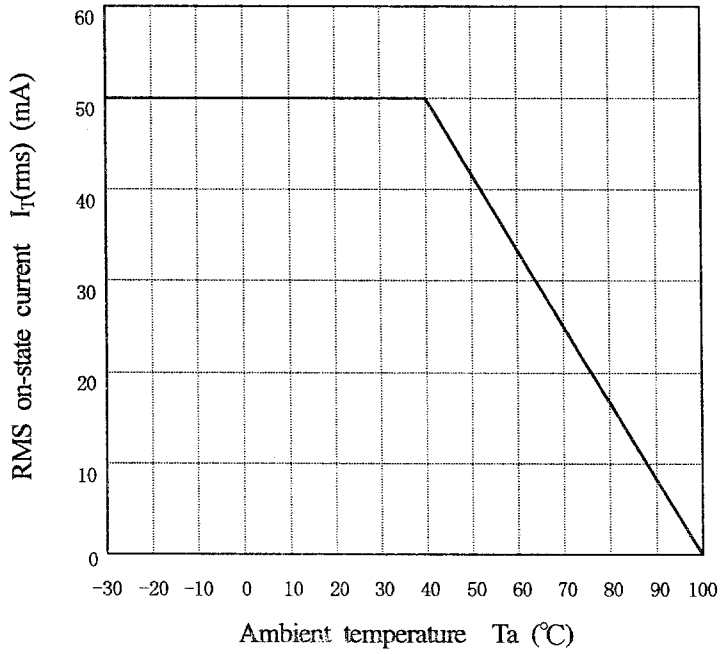

Fig.2 RMS on-state current vs. ambient temperature



4. Reliability

The reliability of products shall satisfy items listed below.

Confidence level : 90%

LTPD : 10 or 20

| Test Items | Test Conditions *1 | Failure Judgement Criteria | Samples (n) |
|--------------------------------------|--|---|--------------|
| | | | Defective(C) |
| Solderability *2 | 245±3°C, 5s | — | n=11, C=0 |
| Soldering heat *3 | (Flow soldering) 260°C, 10s | $V_F > U \times 1.2$ $V_T > U \times 1.2$ $I_{FT} > U \times 1.3$ $I_R > U \times 2.0$ $I_{DRM} > U \times 2.0$ U : Upper specification limit L : Lower specification limit | n=11, C=0 |
| | (Soldering by hand) 400°C, 3 s | | n=11, C=0 |
| Terminal strength (Bending) *4 | Weight : 1.0N 1 time/each terminal | | n=11, C=0 |
| Mechanical shock | 15km/s ² , 0.5ms 3 times/±X, ±Y, ±Z direction | | n=11, C=0 |
| Variable frequency vibration | 100 to 2000 to 100Hz/4min 200m/s ² 4 times/ X, Y, Z direction | | n=11, C=0 |
| Temperature cycling | 1 cycle -40°C to +125°C (30min) (30min) 20 cycles test Without Load | | n=22, C=0 |
| High temp. and high humidity storage | +60°C, 90%RH, 500h | | n=22, C=0 |
| High temp. storage | +125°C, 1000h | | n=22, C=0 |
| Low temp. storage | -40°C, 1000h | | n=22, C=0 |
| Operation life | I _F =50mA, I _T =50mA (θ =180°) Ta=25°C, 1000h | | n=22, C=0 |

*1 Test method, conforms to EIAJ ED 4701.

*2 Solder shall adhere at the area of 95% or more of immersed portion of lead, and pin hole or other holes shall not be concentrated on one portion.

*3 The lead pin depth dipped into solder shall be 0.2mm away from the root of lead pins.

*4 Terminal bending direction is shown below.

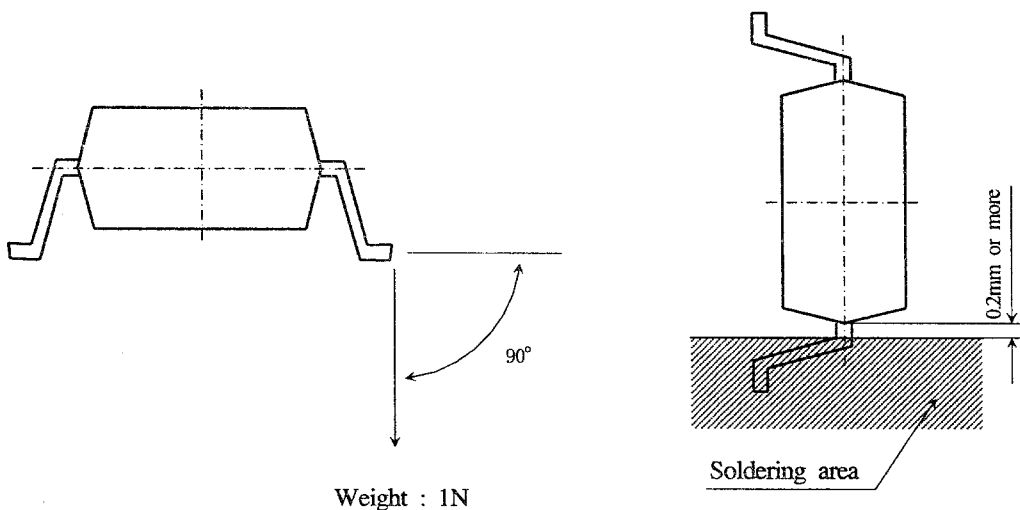

5. Outgoing inspection

5.1 Inspection items

(1) Electrical characteristics

$V_F, I_R, I_{DRM}, V_T, I_{FT}, R_{ISO}, V_{ISO}$

(2) Appearance

5.2 Sampling method and Inspection level

A single sampling plan, normal inspection level II based on ISO 2859 is applied.

The AQL according to the inspection items are shown below.

| Defect | Inspection item | AQL (%) |
|--------------|--|---------|
| Major defect | Electrical characteristics Unreadable marking | 0.065 |
| Minor defect | Appearance defect except the above mentioned. | 0.25 |

6.2.1 Taping conditions

- (1) Tape structure and Dimensions (Refer to the attached sheet, Page 9)

The carrier tape has the heat pressed structure of PS material carries tape and three layers cover tape (PET material base).

- (2) Reel structure and Dimensions (Refer to the attached sheet, Page 10)

The taping reel shall be of plastic (PS material).

- (3) Direction of product insertion (Refer to the attached sheet, Page 10)

Product direction in carrier tape shall direct to the anode mark at the hole side on the tape.

- (4) Joint of tape

The cover tape and carrier tape in one reel shall be jointless.

- (5) The way to repair taped failure devices

Repair taped failure devices cutting a bottom of carrier tape with a cutter, and after replacing to good devices, the cut portion shall be sealed with adhesive tape.

6.2.2 Adhesiveness of cover tape

- The exfoliation force between carrier tape and cover tape shall be 0.2N to 0.7N for the angle 160° to 180° .

6.2.3 Rolling method and quantity

- Wind the tape back on the reel so that the cover tape will be outside the tape.

Attach more than 20cm of blank tape to the trailer and the leader of the tape and fix the both ends with adhesive tape.

One reel shall contain 3000pcs.

6.2.4 Outer packing appearance (Refer to attached sheet, Page 10)

6.2.5 Marking

- The outer packaging case shall be marked with following information.

* Model No. * Number of pieces delivered * Production date

6.2.6 Storage condition

- Taped products shall be stored at the temperature 5 to 30°C and the humidities lower than 70%RH.

6.2.7 Safety protection during shipping

- There shall be no deformation of component or degradation of electrical characteristics due to shipping.

Carrier tape structure and Dimensions

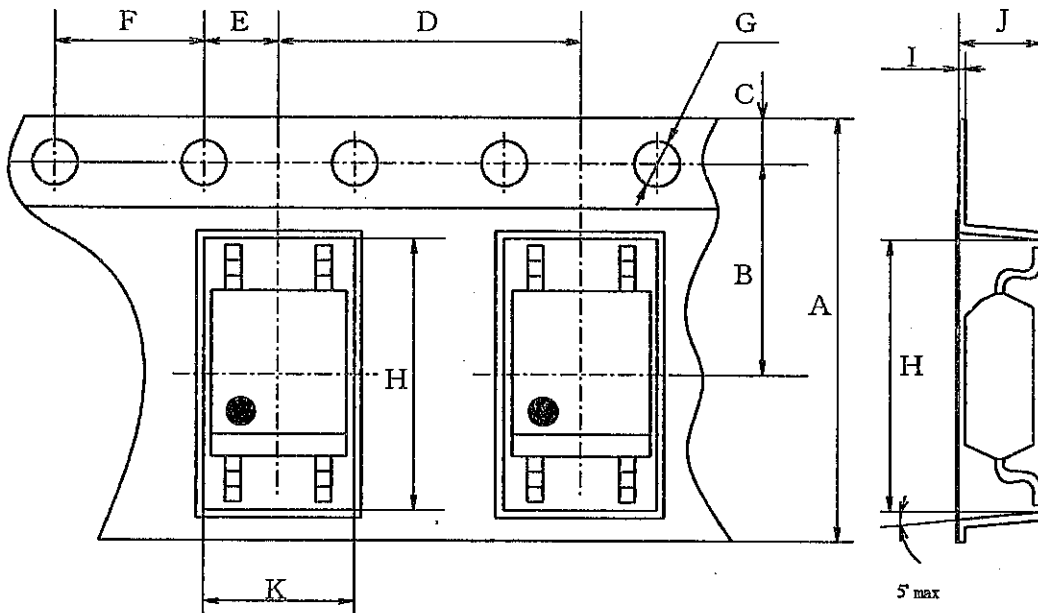

Dimensions list (Unit : mm)

| A | B | C | D | E | F | G | H | I | J | K |
|------|-------|------|------|------|------|--------------|------|-------|------|------|
| ±0.3 | ±0.05 | ±0.1 | ±0.1 | ±0.1 | ±0.1 | +0.1 -0.0 | ±0.1 | ±0.05 | ±0.1 | ±0.1 |
| 12.0 | 5.5 | 1.75 | 8.0 | 2.0 | 4.0 | φ 1.5 | 7.4 | 0.3 | 3.1 | 4.0 |

Reel structure and Dimensions

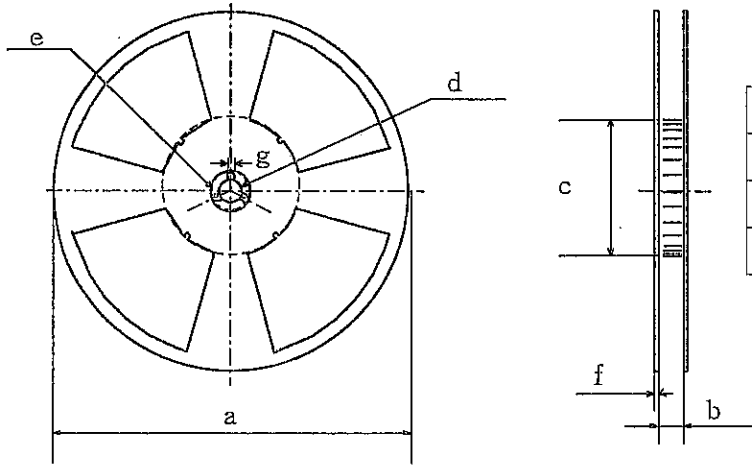

Dimensions list (Unit : mm)

| a | b | c | d |
|------------|----------|----------|------------|
| 370 | 13.5±1.5 | φ 80±1.0 | φ 13.0±0.5 |
| e | f | g | |
| φ 21.0±1.0 | 2.0±0.5 | 2.0±0.5 | |

Direction of product insertion

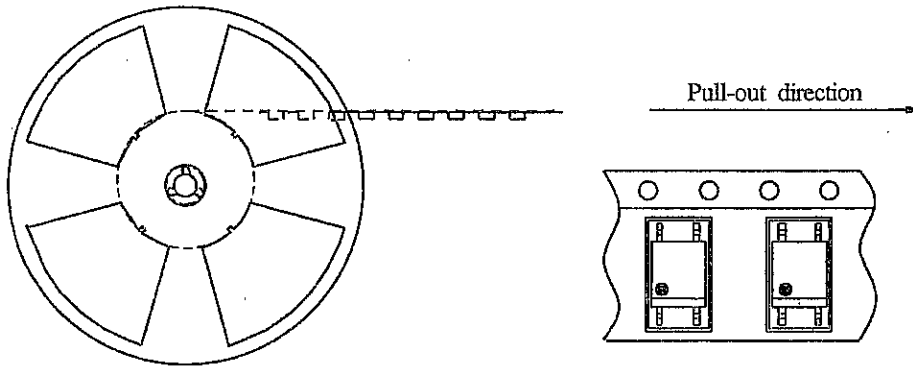

Outer packing appearance

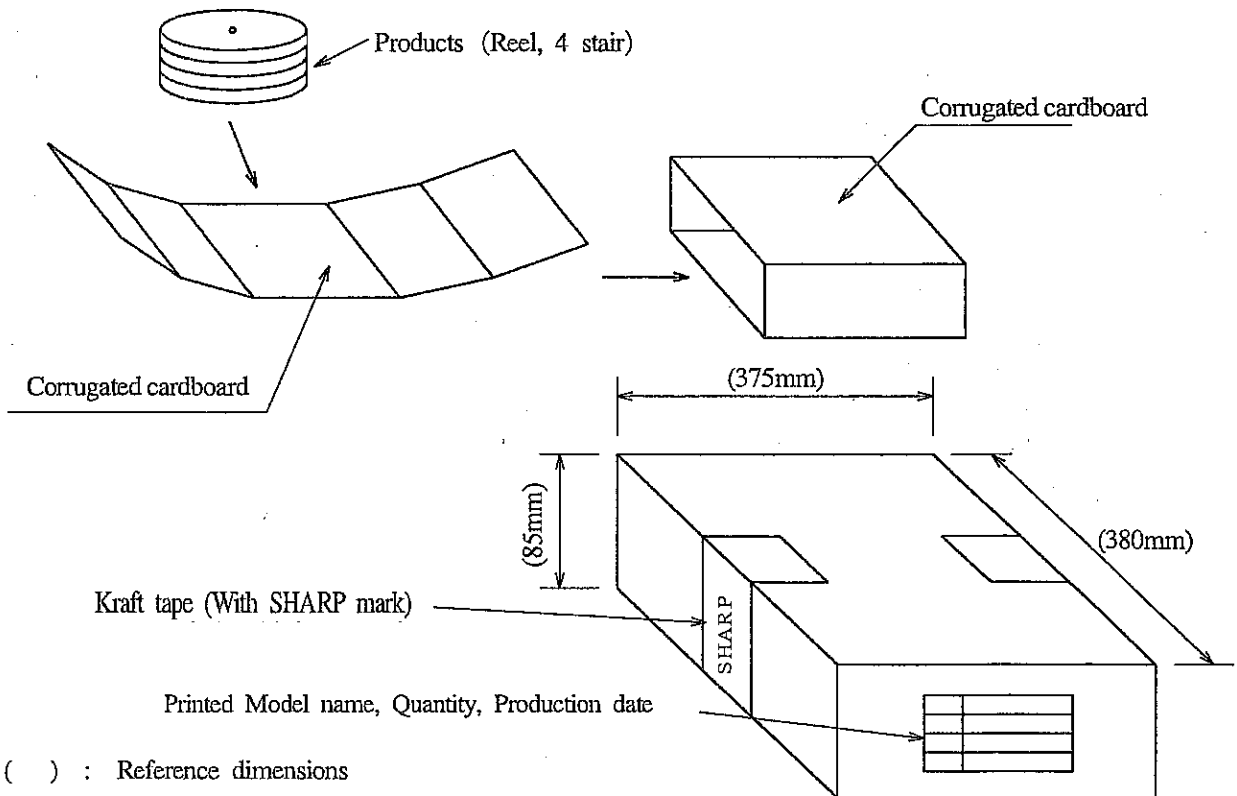

() : Reference dimensions

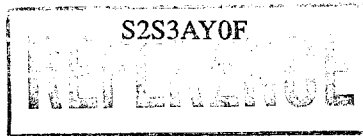

1. This specification shall be applied to photocoupler, Model No. S2S3 series as an option.

2. Applicable Models (Business dealing name)

S2S3AY0F

3. The relevant models are the models Approved by VDE according to DIN EN 60747-5-2.

Up to date code "RD" (December 2003), the relevant models are approved by VDE according to DIN VDE 0884.

Approved Model No. : S2S3

VDE approved No. : 40009162 (According to the specification DIN EN 60747-5-2)

- Operating isolation voltage $U_{IORM(PEAK)}$: 570V
- Transient voltage : 6400V
- Pollution : 2
- Clearances distance (Between input and output) : 4.0mm (MIN.)
- Creepage distance (Between input and output) : 4.0 mm (MIN.)
- Isolation thickness between input and output : 0.15mm (MIN.)
- Tracking-proof : CTI 175
- Safety limit values
 - Current (I_{si}) : 120mA (Diode side)
 - Power (P_{si}) : 200mW (Phototransistor side)
 - Temperature (T_{si}) : 150°C

In order to keep safety electric isolation of photocoupler, please set the protective circuit to keep within safety limit values when the actual application equipment troubled.

- Indication of VDE approval "  " is printed on minimum unit package.

4. Outline

Refer to the attachment-1-2.

5. Isolation specification according to EN 60747-5-2.

| Parameter | Symbol | Conditions | Rating | Unit | Remark |
|--|------------------|---|-----------------------|------|---|
| Class of environmental test | - | - | 30/100/21 | - | Refer to the Diagram 1, 2 (Attachment -1-3) |
| Pollution | - | - | 2 | - | |
| Maximum operating isolation voltage | $U_{IORM(PEAK)}$ | - | 570 | V | |
| Partial discharge test voltage (Between input and output) | Diagram 1 | $t_p=10\text{ s}, q_c < 5\text{ pC}$ | 860 | V | |
| | Diagram 2 | $t_p=1\text{ s}, q_c < 5\text{ pC}$ | 1070 | V | |
| | | | | | |
| Maximum over-voltage | $U_{IOTM(PEAK)}$ | $t_{INT}=60\text{ s}$ | 6400 | V | |
| Safety maximum ratings | | | | | Refer to Fig.1, 2 (Attachment -1-3) |
| 1) Case temperature | T _{si} | I _F =0, P _c =0 | 150 | °C | |
| 2) Input current | I _{si} | P _c =0 | 120 | mA | |
| 3) Electric power (Output or Total power dissipation) | P _{si} | - | 200 | mW | |
| Isolation resistance (Test voltage between input and output ; DC 500V) | R_{ISO} | T _a =T _{si} | MIN. 10 ⁹ | Ω | |
| | | T _a =T _{opr} (MAX.) | MIN. 10 ¹¹ | | |
| | | T _a =25°C | MIN. 10 ¹² | | |

6. Precautions in performing isolation test

6.1 Partial discharge test methods shall be the ones according to the specifications of EN 60747-5-2

6.2 Please don't carry out isolation test (V_{iso}) over U_{IOTM} . This product deteriorates isolation characteristics by partial discharge due to applying high voltage (ex. U_{IOTM}). And there is possibility that partial discharge occurs in operating isolation voltage. (U_{IORM}).

S2S3AY0F
MINIATURE

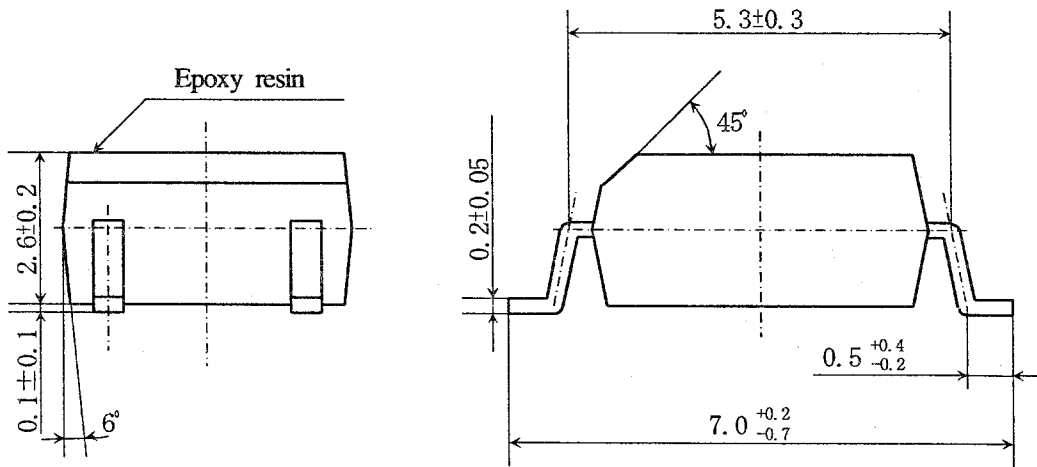
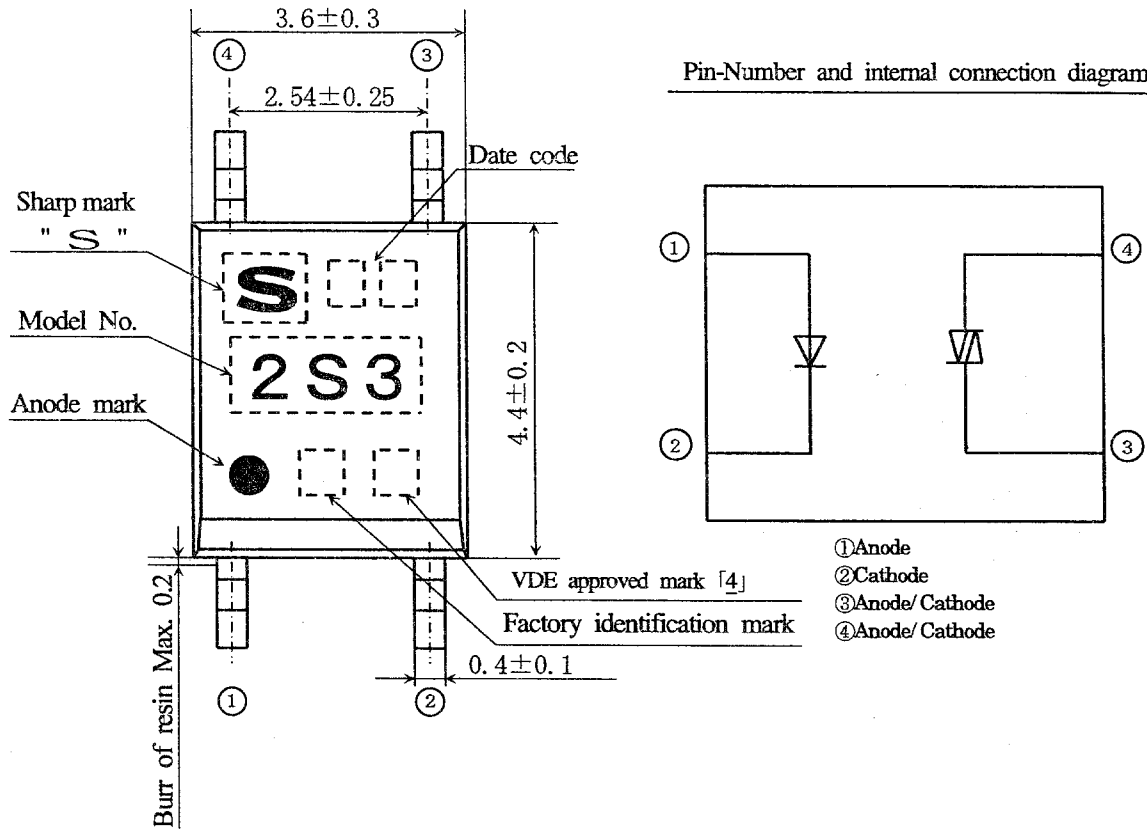

- *1) 2-digit number shall be marked according to OLD DIN standard.
- *2) Factory identification mark shall be or shall not be marked.
- *3) Marking is laser marking
- *4) Pin material : 42Alloy
 Pin finish : SnCu plating (Cu : TYP. 2%)

Product mass : Approx.0.09g

| | |
|---------------|---|
| UNIT : 1/1 mm | |
| Name | S2S3 Outline Dimensions (Business dealing name : S2S3AY0F) |

Method of Diagram 1: Breakdown test (Apply to type test and sampling test)

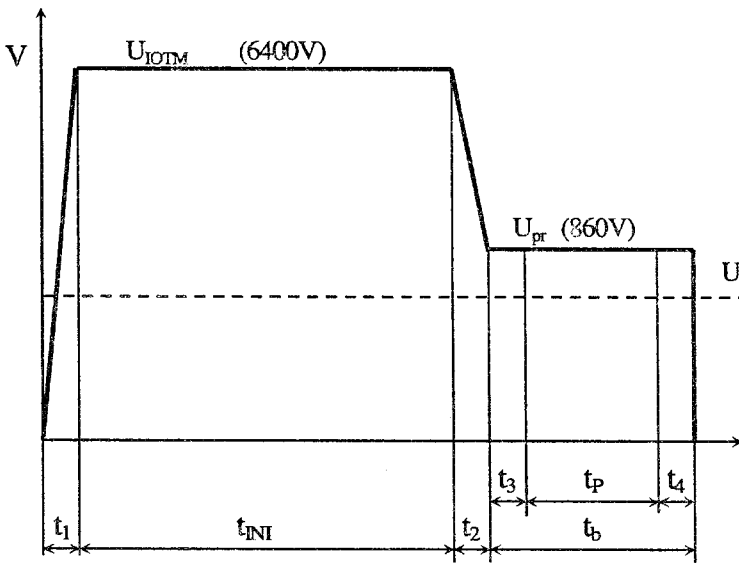

- t_1, t_2 = 1 to 10 s
- t_3, t_4 = 1 s
- t_p (Partial discharge measuring time) = 10 s
- t_b = 12 s
- t_{INI} = 60 s

Method of Diagram 2: Non breakdown test (Apply to all device test)

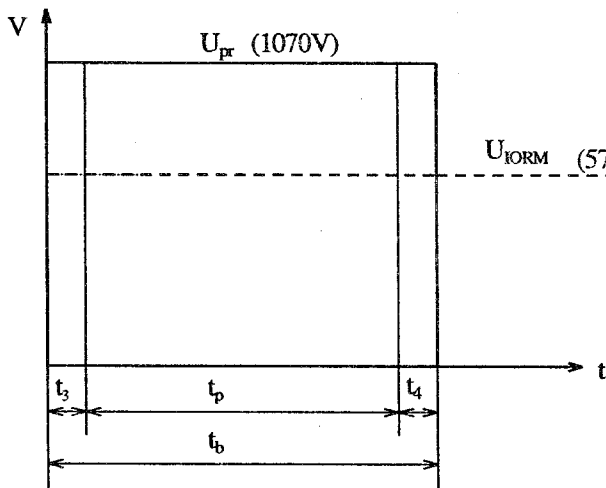

- t_3, t_4 = 0.1 s
- t_p (Partial discharge measuring time) = 1 s
- t_b = 1.2 s

Fig. 1 Safety maximum power dissipation vs. ambient temperature (When failed)

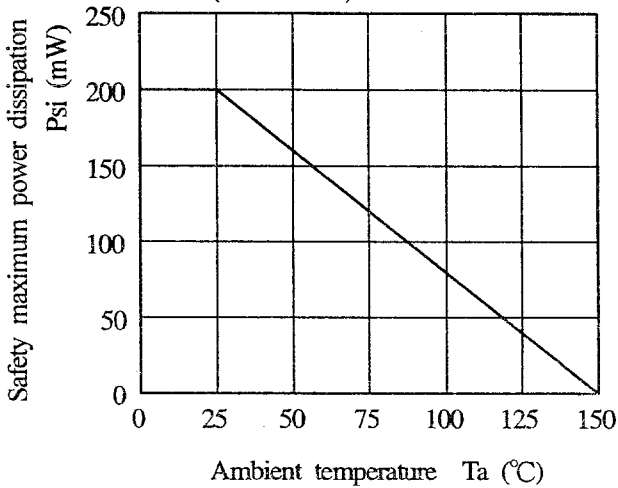
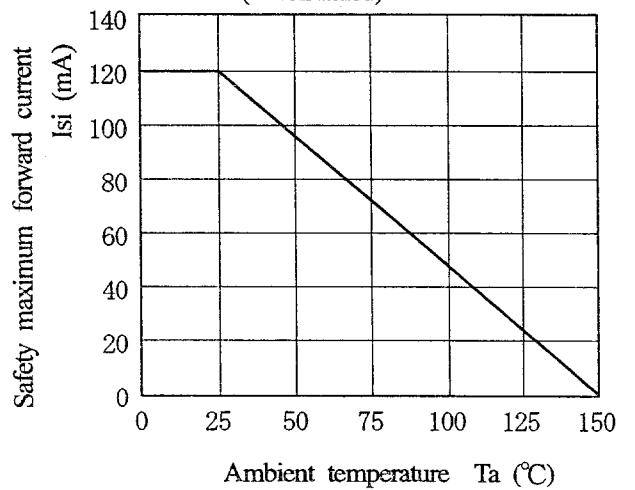

Fig. 2 Safety maximum forward current vs. ambient temperature (When failed)



X-ON Electronics

Largest Supplier of Electrical and Electronic Components

Click to view similar products for [sharp manufacturer:](#)

Other Similar products are found below :

[GP2A240LCS0F](#) [PQ033Y3H3ZZ](#) [LQ070T5CRQ1](#) [GP2Y0E03](#) [GP2Y1026AU0F](#) [1157238](#) [CANGKE412WJ31](#) [LQ150X1LGB1](#)
[CSAKAA233WJ31](#) [PC725V](#) [PC817A](#) [S21ME6IY](#) [LH75400N0M100C0](#) [PT100MF0MP](#) [LQ150X1LG11](#) [PC900V](#) [PC827](#) [PQ09RA11](#)
[PC354NTJ000F](#) [GP1FAV31TK0F](#) [PC847XJ0000F](#) [GL5ZE43](#) [PC123PY2](#) [LH7A400N0E000B3A](#) [GL1HD11](#) [GP1S53VJ000F](#)
[GP1UD282YK](#) [LQ104S1LG81](#) [GP1UM28YK0VF](#) [GP2Y0A51SK0F](#) [LQ080Y5DZ03A](#) [GP1S097HCZ0F](#) [LQ090Y3DG01](#) [GP1UM281XKVF](#)
[GP1UM287QK](#) [LH79524N0F100A1](#) [PD3122F](#) [PC4SD21YXPDH](#) [PQ1U251M2ZPH](#) [PC817X4J000F](#) [PC823](#) [LS037V7DW03A](#)
[PQ1CG3032RZ](#) [GP1UM277XK](#) [GP1S51VJ000F](#) [GP2Y0A21YK0F](#) [PQ1K503M2ZP](#) [PC923LENIP0F](#) [GM1WA80350A](#) [LQ084S3LG03](#)