

SMART RTD/RESISTANCE/SLIDE WIRE SIGNAL CONDITIONER

SEM1600T

- SUITABLE FOR RTD, THERMOCOUPLE AND SLIDE WIRE SENSORS
- CURRENT, VOLTAGE OR BIPOLAR VOLTAGE OUTPUT
- POWERED (10 to 32) V AC / (10 to 48) V DC SUPPLY
- 22 SEGMENT USER LINEARISATION
- SENSOR OFFSET AND OUTPUT ALIGNMENT
- ADJUSTABLE INPUT FILTER
- USB PROGRAMMABLE

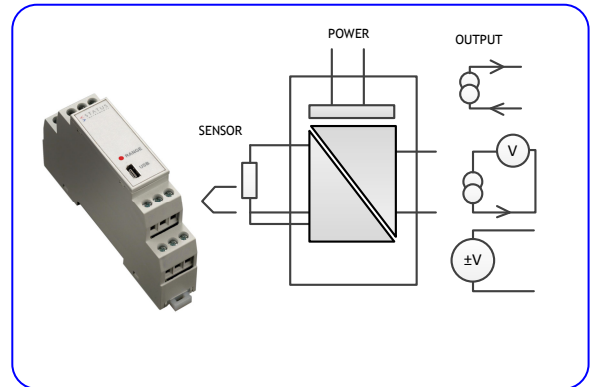

INTRODUCTION

The SEM1600T accepts resistance or mV signals from RTD, Slidewire or Thermocouple sensors. The flexible design allows the use of any resistive sensor within the range of (10 to 10500) Ω. Including Pt100, 500, 1000, Ni or Cu sensors, slide wire sensors up to 100 KΩ and 13 different thermocouple types. Other sensor characteristics or your own 22 point linearisation characteristic (for slidewire, linear resistance or mV) can be downloaded into the product enabling you to adapt it exactly to your application.

The output stage offers either voltage, bipolar voltage or current re-transmission signals. The retransmission signal can be ranged to a scale anywhere within the input process range. A transmitter power supply is provided on the output meaning the product can accept sink or source mA applications. While the voltage output will drive 2 mA into 5 KΩ @ 10 V

For ease of use, a high efficiency switch mode power supply is fitted as standard and does not require any adjustment between ac or dc applications. Operating voltages are (10 to 48) V dc and (10 to 32) V ac

Our USB interface is fitted for quick and easy configuration. Just connect a standard USB cable between the SEM1600T and your PC. Using our free configuration software, your PC will automatically upload the existing configuration data and guide you through any changes you wish to make. To further help save time, the SEM1600T does not need to be wired to a power supply during the configuration process, it is powered via the USB interface from your PC.

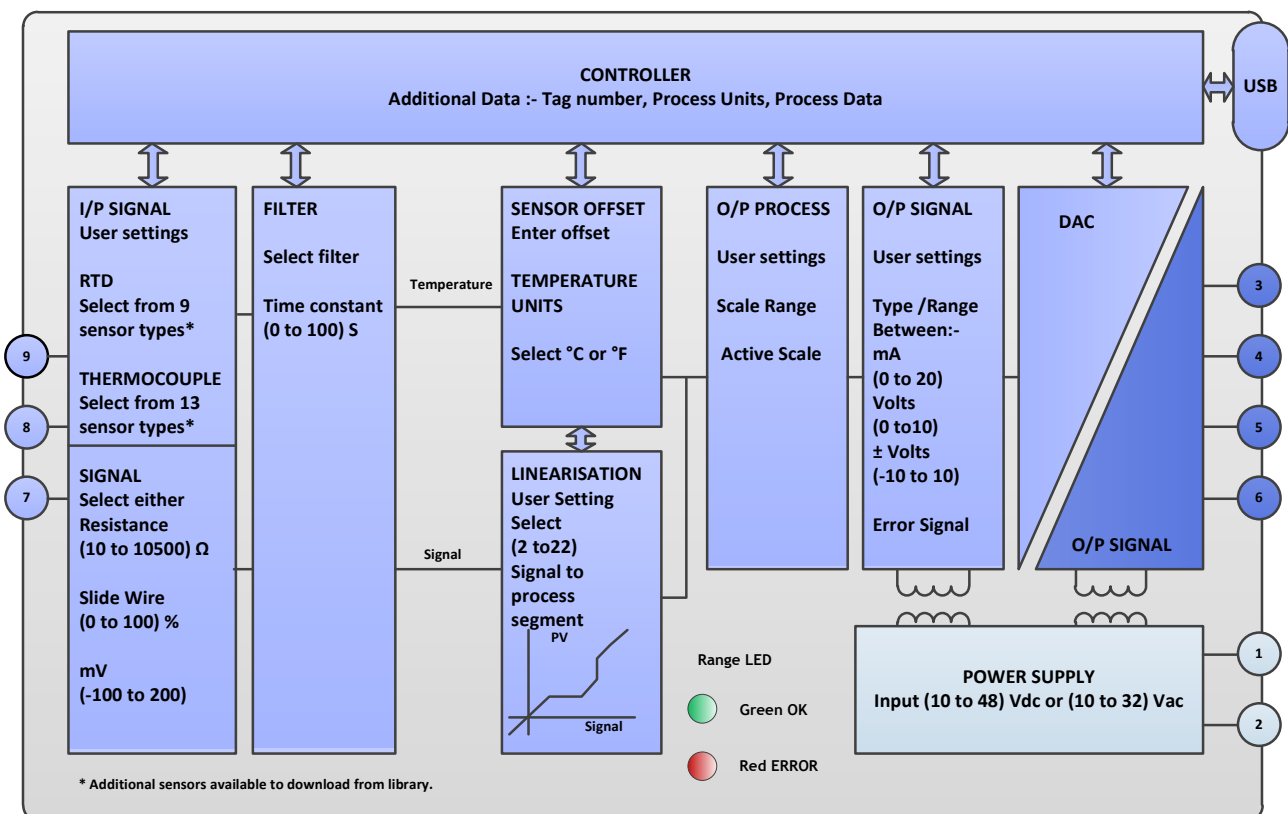

SMART RTD/RESISTANCE/SLIDE WIRE SIGNAL CONDITIONER

SPECIFICATION @20 °C

RESISTANCE RTD INPUT

Standard RTD
Slide wire
Resistance
Thermal Drift

Excitation current
Lead effect

PT100,PT500,PT1000, Cu100, Cu1000, Ni100, Ni120, Ni1000, Cu53, library
Pot range (1 to 100) KΩ, Signal (0 to 100) %, accuracy 0.1 %
10 to 500) Ω ± 0.055 Ω, (500 to 2500) Ω ± 0.5 Ω, (2500 to 10500) Ω ± 10.0 Ω.
(0 to 500) Ω 0.013 Ω/°C, (500 to 2500) Ω 0.063 Ω/°C,
(2500 to 10500) Ω 0.27 Ω/°C
< 200 uA
Max lead resistance 20 Ω per leg, Effect 0.002 °C/Ω

THERMOCOUPLE mV INPUT

Standard TC
mV
Thermal Drift
Cold Junction

Types K,J,E,N,T,R,S,L,U,B,C(w5),D(W3),G(W),library
(-100 to 200) mV ± 0.02% of full scale.
Thermocouple offset 0.1 °C/°C, span 0.05 °C/°C
Range (-40 to 85) °C, Accuracy ± 0.2 °C, ± 0.05 °C/°C

OUTPUT CURRENT

Current Source
Current Sink
Accuracy

Range (0 to 21.5) mA , Max Load 750 Ω
Range (0 to 21.5) mA , Supply (10 to 30) V dc, Voltage effect 0.2 uA/V
(mA Out/ 2000) or 5 uA which ever is the greater, Drift 1 uA/°C

OUTPUT VOLTAGE

Range
Current Drive

(0 to 10.1) V or (-10.1 to 10.1) V, Accuracy ± 5 mV
± 2 mA, Min load 5000 Ω @ 10 V

SUPPLY

Range
Power

(10 to 48) VDC , (10 to 32) VAC Protected by internal 500 mA resettable fuse.
< 1W Full Power

GENERAL

Response time
Isolation
Indication

Start up 5 seconds, Update 300 mS, Response 400 mS, Warm up 2 minutes.
Supply to input to output 500 V dc.
LED, Green when output (-0.1 to 100.1) %, else red

USER INTERFACE

Type
Baud rate
Equipment

USB 2.0
19,200 baud
PC running windows XP or later, USB cable.

USER INTERFACE FUNCTIONS

Scaling
Filter
User Linearisation (Profile)
Process Units
Temperature units
Tag Number
Process Output
Signal Output
User offset
Active scaling

User signal to process value scaling, for simplified setup.
Adjustable time constant (0 to 100) Seconds.
(2 to 22) segments Ω (slide wire) and mV to process.
4 Characters (signal input only)
°C or °F (TC, RTD inputs only)
20 Characters
Range in process units
Select type, signal range and (temperature only) error signal.
Enter sensor offset (Temperature mode only).
Set output process range against active sensor input

ENVIRONMENT

Operating Ambient
Storage Ambient
Configuration Ambient
Installation Enclosure

(-30 to 70) °C; (10 to 90) %RH (non condensing)
(-30 to 70) °C; (10 to 90) %RH (non condensing)
(10 to 30) °C
DIN Rail enclosure offering Protection >= IP65.

APPROVALS

CE
BS EN 61326

MECHANICAL

Style
Terminals

DIN 43880, Colour grey, material Polymide 6.6, weight < 70 grams
2.5 mm Maximum

SENSORS RTD

Platinum IEC
Platinum IPTS-68
Ni100 DIN 0.00618
Ni120 0.00672
Ni 1000
Ni1000 Tk5000
Ni 507.5
Ni 604
Cu 53
Cu100 0.00427
Cu1000
Silicon

Accuracy = 0.2 °C + (°0.05% of reading) (Plus sensor error)
Pt100 (-200 to 850), Pt500 (-200 to 750), Pt1000 (-200 to 600)
Pt100 (0.00391) + Pt100 (0.00392) (-200 to 630)
(-60 to 180)
(-80 to 260)
(-60 to 180)
(-50 to 150)
(-80 to 360)
(-200 to 200)
(-50 to 180)
(-80 to 260)
(-80 to 260)
KTY81-110 -120-121-122-150-210-220-221-222-250 (-55 to 175)
KTY82-110 -120-121-122-150-210-220-221-222-250 (-55 to 175)
KTY81-151, KTY82-151, KTY83-210-220-250-121-122 (-55 to 175)
KTY84-130-150 (-40 to 300)

SENSORS THERMOCOUPLE

Types

Accuracy ±0.1 % of full scale ± 0.5 °C (plus sensor error)
K (-200 to 1370), J (-100 to 1200), E (-200 to 1000), N (-180 to 1300)
L (-100 to 600), U (0 to 600), B (0 to 1800), C - D - W (0 to 2300)
Accuracy ±0.2 % of full scale ± 0.5 °C (plus sensor error)
T (-200 to 400)
Accuracy ± 0.1 % of full scale plus ± 0.5 °C (range 800 to 1600)
R (0 to 1760), S (0 to 1760)

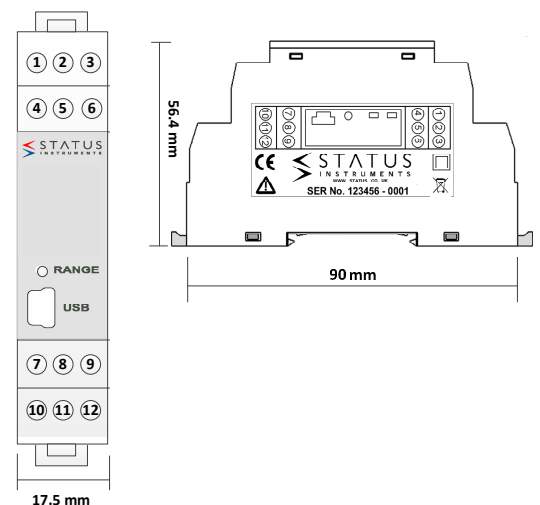
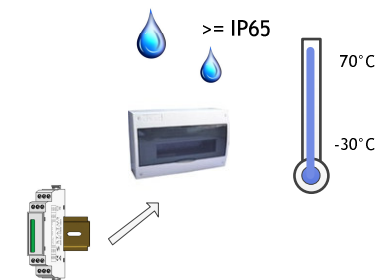
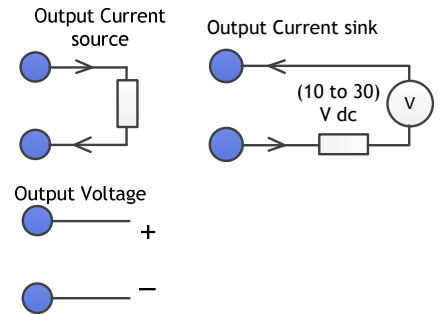
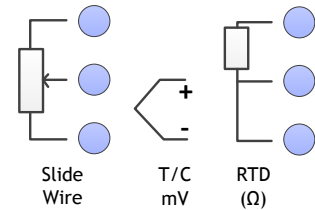

Order code:

SEM1600T

Status Instruments Ltd
Green Lane Business Park
Green Lane, Tewkesbury
Gloucestershire, UK
GL20 8DE

Tel: +44 (0)1684 296818
Fax: +44 (0)1684 293746
Email: sales@status.co.uk
Website: www.status.co.uk
D2538-01-03 CN50481600T Data sheet



X-ON Electronics

Largest Supplier of Electrical and Electronic Components

Click to view similar products for [Terminal Block Interface Modules](#) category:

Click to view products by [Status](#) manufacturer:

Other Similar products are found below :

[73-551-6002I](#) [GCN1MX25B](#) [11S](#) [DIN-50P-01](#) [DIN-68H-01](#) [DIN-96DI-01](#) [2291901](#) [2900185](#) [2903392](#) [2907794](#) [2M10FCL](#) [2281759](#)
[2906249](#) [2907808](#) [TB ML 3P ST D5.08](#) [5604442](#) [XW2B-40G5-T](#) [5606629](#) [XW2B-20G5-D](#) [2903870](#) [5541988](#) [5541962](#) [1776613-1](#) [XW2B-](#)
[34G4](#) [XW2B-60G5](#) [XW2R-E34G-C1](#) [XW2R-E34G-C3](#) [XW2R-J40G-T](#) [XW2R-P34G-C4](#) [XW2B-50G5](#) [XW2R-E40G-T](#) [XW2R-E34G-C2](#)
[XW2R-J34G-C2](#) [ADAM-3920R-AE](#) [060-6827-06](#) [2311030](#) [2287708](#) [XW2C-20G6-IO16](#) [XW2R-J20G-T](#) [XW2B-60G4](#) [GCN1-T](#)
[00111550102](#) [2908853](#) [2908851](#) [2908852](#) [2908850](#) [1033201](#) [5541234](#) [410-261](#) [5521322](#)