

High Frequency Planar Transformers

Spyglass Series (up to 140W)



- Power Rating:** up to 140W
- Height:** 8.6mm MAX and 9.7mm MAX
- Footprint:** 23.4mm x 20.1mm MAX
- Frequency Range:** 235kHz to 700kHz

Electrical Specifications @ 25°C - Operating Temperature -40°C to +125°C

Part ^{4,5} Number	Power ¹ Rating	Turns Ratio (Pri:Sec)	Primary ² Secondary Isolation	Primary Inductance (μH MIN)	Leakage Inductance* (μH MAX)	DCR (mΩ MAX)			Maximum Height (mm)
						Primary	Primary Aux.	Secondary	
PA0168NL	100W 48v to 3.3v/30A	12:2	1500 Vdc Basic	320	0.75	45	N/A	1.30	8.6
PA0369NL	100W 48v to 3.3v/30A	6:1	1500 Vdc Basic	65	0.25	15	N/A	0.40	8.6
PA0423NL	140W 48v to 12v/11.7A	8:4 (w/4T Pri. Aux.)	1500 Vdc Basic	140	0.30	35	500	7.00	8.6
PA0463NL	50W 48v to 3.3v/15A	10:2 (w/9T Pri. Aux.)	1500 Vdc Basic	200	1.00	40	4885	2.50	8.6
PA0491NL	100W 48v to 5v/20A	8:2	1500 Vdc Basic	140	0.25	35	N/A	1.30	8.6
PA0634NL	100W 48v to 5v/20A	8:2 (w/5T Pri. Aux.)	1500 Vdc Basic	140	0.38	35	460	1.30	8.6
PA0693NL	100W 48v to 5v/25A	12:3 (w/4T Pri. Aux.)	1500 Vdc Basic	346	0.55	50	300	3.50	9.7

Mechanicals

PAOXXXNL

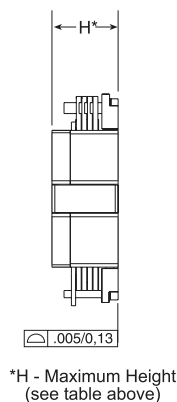
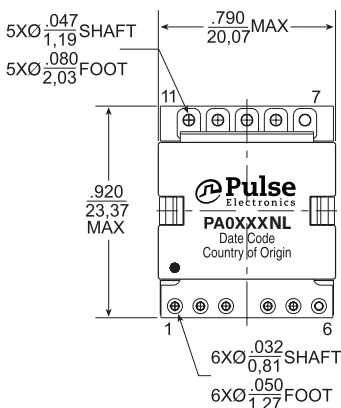

SUGGESTED PAD LAYOUT

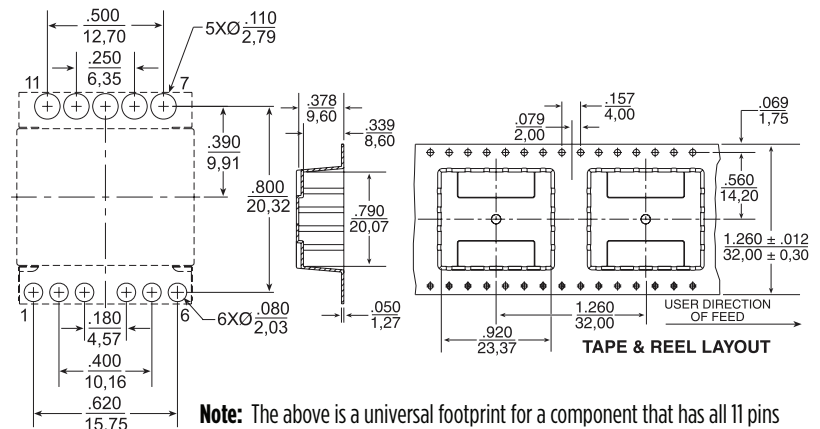

Note: The above is a universal footprint for a component that has all 11 pins populated. For a given part number, it is only necessary to provide pads for the terminations shown in the schematic below.

Weight0.8grams
Tape & Reel400/reel
Tray40/tray

Dimensions: $\frac{\text{Inches}}{\text{mm}}$ Unless otherwise specified, all tolerances are $\pm \frac{.010}{0.25}$

USA 858 674 8100

Germany 49 7032 7806 0

Singapore 65 6287 8998

Shanghai 86 21 62787060

China 86 755 33966678

Taiwan 886 3 4356768

High Frequency Planar Transformers

Spyglass Series (up to 140W)

Schematics

PA0XXX

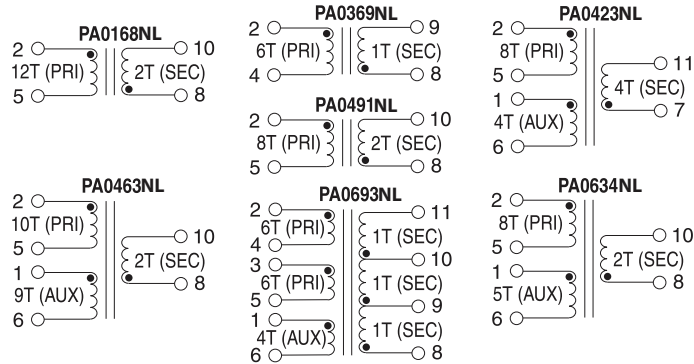

Notes from Tables:

- The above transformers have been tested and approved by Pulse's IC partners and are cited in the appropriate datasheet or evaluation board documentation at these companies. To determine which IC and IC companies are matched with the above transformers, please refer to the IC cross reference on the Pulse web page. See the Spyglass transformer matrix on the next page for other winding configurations that can be made available.
- The listed transformers are designed to meet basic insulation (1.4mm creepage and clearance with 1500Vdc isolation). Lower cost transformers with operational insulation (1500Vdc isolation with no creepage and clearance spacings) are available. Please contact Pulse Power Applications Engineering for details.
- To determine if the transformer is suitable for your application, it is necessary to ensure that the temperature rise of the component (ambient plus temperature rise) does not exceed its operating temperature. To determine the approximate temperature rise of the transformer, refer to the graphs below.
- Add suffix "T" to the part number for Tape & Reel package (i.e. PA0168T).

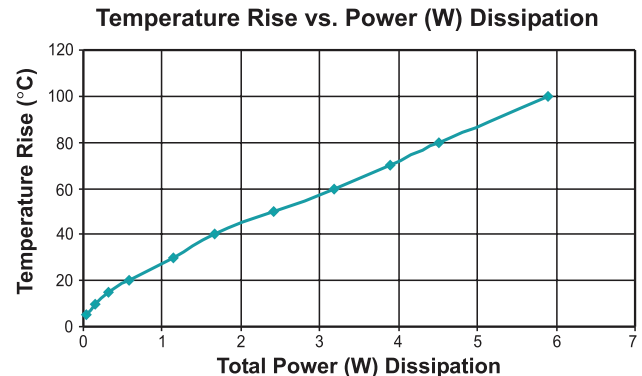
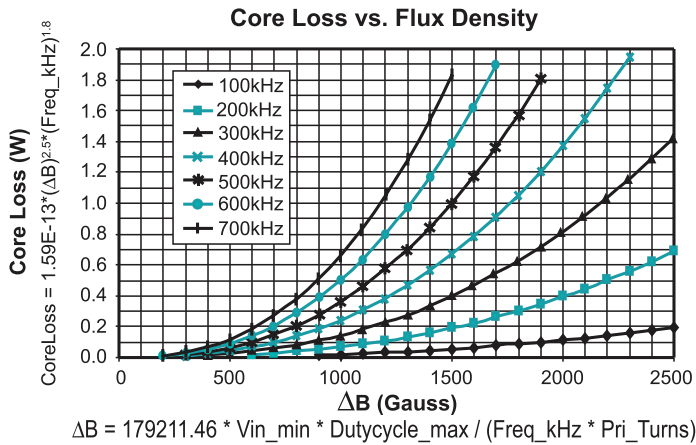

$$\text{Total Power Dissipation (W)} = .001 * (\text{DCR}_{\text{primary}} * \text{Irms}_{\text{primary}}^2 + \text{DCR}_{\text{secondary}} * \text{Irms}_{\text{secondary}}^2) + \text{Core Loss (W)}$$

For More Information

Pulse Worldwide Headquarters
12220 World Trade Drive
San Diego, CA
92128
U.S.A.

Tel: 858 674 8100
Fax: 858 674 8262

Pulse Europe
Einsteinstrasse 1
D-71083 Herrenberg
Germany

Tel: 49 7032 78060
Fax: 49 7032 7806 135

Pulse China Headquarters
B402, Shenzhen Academy of
Aerospace Technology Bldg.
10th Kejian Road
High-Tech Zone
Nanshan District
Shenzhen, PR China
518057
Tel: 86 755 33966678
Fax: 86 755 33966700

Pulse North China
Room 2704/2705
Super Ocean Finance
Ctr.
2067 Yan An Road
West
Shanghai 200336
China
Tel: 86 21 62787060
Fax: 86 2162786973

Pulse South Asia
135 Joo Seng Road
#03-02
PM Industrial Bldg.
Singapore 368363
Tel: 65 6287 8998
Fax: 65 6287 8998

Pulse North Asia
3F, No. 198
Zhongyuan Road
Zhongli City
Taoyuan County 320
Taiwan R. O. C.
Tel: 886 3 4356768
Fax: 886 3 4356823 (Pulse)
Fax: 886 3 4356820 (FRE)

Performance warranty of products offered on this data sheet is limited to the parameters specified. Data is subject to change without notice. Other brand and product names mentioned herein may be trademarks or registered trademarks of their respective owners. © Copyright, 2015, Pulse Electronics, Inc. All rights reserved.

X-ON Electronics

Largest Supplier of Electrical and Electronic Components

Click to view similar products for [Audio Transformers](#) / [Signal Transformers](#) category:

Click to view products by [Pulse manufacturer](#):

Other Similar products are found below :

[749023020](#) [CU4S0506AT-2655-H1](#) [MET-58](#) [PE-64961](#) [H5008FNL](#) [H5020FNLT](#) [H5079NLT](#) [1879479-1](#) [1879564-1](#) [PA1277NLT](#)
[PA1528ANL](#) [PA2007NLT](#) [FL1066](#) [T1137NLT](#) [T3012NL](#) [PE-65812FNL](#) [TTC-100](#) [TTC-143-H](#) [TTC-5032-1](#) [HX1234NLT](#) [HX5008FNLT](#)
[100B-1001XNL](#) [PA1282NLT](#) [HX5084FNL](#) [T1108NLT](#) [2-1879391-5](#) [TTC-266-2](#) [3-1879385-4](#) [PA1032NL](#) [H2009FNLT](#) [PA0801NLT](#)
[TTC-266](#) [X-1619](#) [SM51295PEL](#) [T5008NLT](#) [PE-68517T](#) [HX1294NLT](#) [HX5084FNLT](#) [H5015FNLT](#) [H6080NLT](#) [CX2024NL](#) [HX1294FNLT](#)
[TX1473NLT](#) [PE-69011NLT](#) [CX2047LNLT](#) [CX2043LNLT](#) [DCT20EFD-U32S003](#) [H5120NLT](#) [H7137FNLT](#) [H1259NLT](#)