

FEATURES

EEMBC ULPBench™ score: 245.5

Ultralow power active and hibernate modes

Active (full on mode) < 30 μ A/MHz (typical)

Flexi™ (core in sleep, peripherals active) < 300 μ A (typical)

Hibernate (with SRAM retention) < 750 nA (typical)

Shutdown (optional RTC active) < 60 nA (typical)

ARM® Cortex®-M3 processor with MPU

Up to 26 MHz with serial wire debug interface

Power management

Single-supply operation (VBAT): 1.74 V to 3.6 V

Optional buck converter for improved efficiency

Memory options

128 KB/256 KB of embedded flash memory with ECC

4 KB of cache memory to reduce active power

64 KB of configurable system SRAM with parity

Up to 32 KB of SRAM retained in hibernate mode

Safety

Watchdog with dedicated on-chip oscillator

Hardware CRC with programmable polynomial

Multiparity bit protected SRAM

ECC protected embedded flash

Security

TRNG

User code protection

Hardware cryptographic accelerator supporting AES-128, AES-256, and SHA-256

DIGITAL PERIPHERALS

3 SPI interfaces to enable glueless interface to sensors, radios, and converters

I²C and UART interfaces

SPORT for natively interfacing with converters and radios

Programmable GPIOs (44 in LFCSP and 36 in WLCSP)

3 general-purpose timers with PWM support

RTC and FLEX_RTC with SensorStrobe™ and time stamping

Programmable beeper

25-channel DMA controller

CLOCKING FEATURES

26 MHz clock: on-chip oscillator, external crystal oscillator

32 kHz clock: on-chip oscillator, low power crystal oscillator

Integrated PLL with programmable divider

ANALOG PERIPHERALS

12-bit SAR ADC, 1.8 MSPS, 8 channels, digital comparator

APPLICATIONS

Internet of Things (IoT)

Smart machine, smart metering, smart building,
smart city, smart agriculture

Wearables

Fitness and clinical

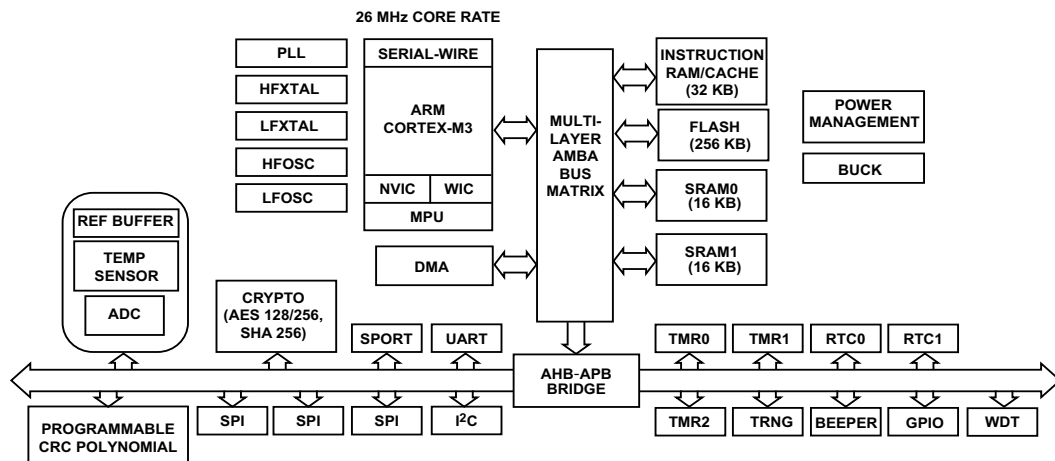

Figure 1. Functional Block Diagram

Rev. 0

Document Feedback

Information furnished by Analog Devices is believed to be accurate and reliable. However, no responsibility is assumed by Analog Devices for its use, nor for any infringements of patents or other rights of third parties that may result from its use. Specifications subject to change without notice. No license is granted by implication or otherwise under any patent or patent rights of Analog Devices. Trademarks and registered trademarks are the property of their respective owners.

TABLE OF CONTENTS

General Description	3	System Clocks/Timers	14
Highlights	3	ADC Specifications	15
ARM Cortex-M3 Processor	3	Flash Specifications	15
Memory Architecture	4	Absolute Maximum Ratings	16
System and Integration Features	5	ESD Sensitivity	16
On-Chip Peripheral Features	10	Package Information	16
Development Support	10	Timing Specifications	17
Additional Information	11	MCU Test Conditions	25
Reference Designs	11	Driver Types	25
Security Features Disclaimer	11	Environmental Conditions	28
Specifications	12	Pin Configuration And Function Description	29
Operating Conditions	12	Outline Dimensions	36
Electrical Characteristics	12	Ordering Guide	37

REVISION HISTORY

3/2017—Revision 0: Initial Version

GENERAL DESCRIPTION

The [ADuCM3027/ADuCM3029](#) microcontroller units (MCUs) are ultra low power microcontroller systems with integrated power management for processing, control, and connectivity. The MCU system is based on the ARM Cortex-M3 processor, a collection of digital peripherals, embedded SRAM and flash memory, and an analog subsystem which provides clocking, reset, and power management capability in addition to an analog-to-digital converter (ADC) subsystem. For a feature comparison across the [ADuCM3027/ADuCM3029](#) product offerings, see [Table 1](#).

Table 1. Product Flash Memory Options

Device	Embedded Flash Memory Size
ADuCM3029	256 KB
ADuCM3027	128 KB

System features that are common across the [ADuCM3027/ADuCM3029](#) MCUs include the following:

- Up to 26 MHz ARM Cortex-M3 processor
- Up to 256 KB of embedded flash memory with error correction code (ECC)
- Optional 4 KB cache for lower active power
- 64 KB system SRAM with parity
- Power management unit (PMU)
- Multilayer advanced microcontroller bus architecture (AMBA) bus matrix
- Central direct memory access (DMA) controller
- Beeper interface
- Serial port (SPORT), serial peripheral interface (SPI), inter-integrated circuit (I²C), and universal asynchronous receiver/transmitter (UART) peripheral interfaces
- Cryptographic hardware support with advanced encryption standard (AES) and secure hash algorithm (SHA) -256
- Real-time clock (RTC)
- General-purpose and watchdog timers
- Programmable general-purpose input/output (GPIO) pins
- Hardware cyclic redundancy check (CRC) calculator with programmable generator polynomial
- Power-on reset (POR) and power supply monitor (PSM)
- 12-bit successive approximation register (SAR) ADC
- True random number generator (TRNG)

To support low dynamic and hibernate power management, the [ADuCM3027/ADuCM3029](#) MCUs provide a collection of power modes and features, such as dynamic and software controlled clock gating and power gating.

For full details on the [ADuCM3027/ADuCM3029](#) MCUs, refer to the [ADuCM302x Ultra Low Power ARM Cortex-M3 MCU with Integrated Power Management Hardware Reference](#).

HIGHLIGHTS

The following are the key features of the [ADuCM3027/ADuCM3029](#) MCUs:

- Industry leading ultralow power consumption.
- Robust operation.
 - Full voltage monitoring in deep sleep modes.
 - ECC support on flash.
 - Parity error detection on SRAM memory.
- Leading edge security.
 - Fast encryption provides read protection to customer algorithms.
 - Write protection prevents device reprogramming by unauthorized code.
- Failure detection of 32 kHz LFXTAL via interrupt.
- SensorStrobe for precise time synchronized sampling of external sensors.
 - Works in hibernate mode, resulting in drastic current reduction in system solutions. Current consumption reduces by 10 times when using, for example, the [ADXL363](#) accelerometer.
 - Software intervention is not required after setup.
 - No pulse drift due to software execution.

ARM CORTEX-M3 PROCESSOR

The ARM Cortex-M3 core is a 32-bit reduced instruction set computer (RISC). The length of the data can be 8 bits, 16 bits, or 32 bits. The length of the instruction word is 16 bits or 32 bits.

The processor has the following features:

- Cortex-M3 architecture
 - Thumb-2 instruction set architecture (ISA) technology
 - Three-stage pipeline with branch speculation
 - Low latency interrupt processing with tail chaining
 - Single-cycle multiply
 - Hardware divide instructions
 - Nested vectored interrupt controller (NVIC) (64 interrupts and 8 priorities)
 - Two hardware breakpoints and one watchpoint (unlimited software breakpoints using Segger JLink)
- Memory protection unit (MPU)
 - Eight-region MPU with subregions and background region
 - Programmable clock generator unit

ADuCM3027/ADuCM3029

- Configurable for ultralow power operation
 - Deep sleep mode, dynamic power management
 - Programmable clock generator unit

ARM Cortex-M3 Memory Subsystem

The memory map of the [ADuCM3027/ADuCM3029](#) is based on the Cortex-M3 model from ARM. By retaining the standardized memory mapping, it is easier to port applications across M3 platforms.

The [ADuCM3027/ADuCM3029](#) application development is based on memory blocks across code/SRAM regions. Internal memory is available via internal SRAM and internal flash.

Code Region

Accesses in this region (0x0000 0000 to 0x0001 FC00 for the [ADuCM3027](#) and 0x0000 0000 to 0x0003 FFFF for the [ADuCM3029](#)) are performed by the core and target the memory and cache resources.

SRAM Region

Accesses in this region (0x2000 0000 to 0x2004 7FFF) are performed by the ARM Cortex-M3 core. The SRAM region of the core can otherwise act as a data region for an application.

- **Internal SRAM Data Region.** This space can contain read/write data. Internal SRAM can be partitioned between code and data (SRAM region in M3 space) in 32 KB blocks. Access to this region occurs at core clock speed with no wait states. It also supports read/write access by the Cortex-M3 core and read/write DMA access by system devices. It supports exclusive memory accesses via the global exclusive access monitor within the Cortex-M3 platform.
- **System MMRs.** Various system memory mapped registers (MMRs) reside in this region.

System Region

Accesses in this region (0xE000 0000 to 0xF7FF FFFF) are performed by the ARM Cortex-M3 core and are handled within the Cortex-M3 platform.

- **CoreSight™ ROM.** The read only memory (ROM) table entries point to the debug components of the processor.
- **ARM APB Peripheral.** This space is defined by ARM and occupies the bottom 256 KB/128 KB of the system (SYS) region (0xE000 0000 to 0xE004 0000) depending on the device used. The space supports read/write access by the M3 core to the internal peripherals of the ARM core (NVIC, system control space (SCS), wake-up interrupt controller (WIC)) and CoreSight ROM. It is not accessible by system DMA.

MEMORY ARCHITECTURE

The internal memory of the [ADuCM3027/ADuCM3029](#) is shown in [Figure 2](#). It incorporates up to 256 KB of embedded flash memory for program code and nonvolatile data storage, 32 KB of data SRAM, and 32 KB of SRAM (configured as instruction space or data space).

SRAM Region

This memory space contains the application instructions and literal (constant) data that must be accessed in real-time. It supports read/write access by the ARM Cortex-M3 core and read/write DMA access by system peripherals. Byte, half-word, and word accesses are supported.

SRAM is divided into 32 KB data SRAM and 32 KB instruction SRAM. If instruction SRAM is not enabled, then the associated 32 KB can be mapped as data SRAM, resulting in 64 KB of data SRAM.

Parity bit error detection (optional) is available on all SRAM memories. Two parity bits are associated with each 32-bit word.

When the cache controller is enabled, 4 KB of the instruction SRAM is reserved as cache memory.

Users can select the SRAM configuration modes depending on the instruction SRAM and cache needed.

In hibernate mode, 8 KB to 32 KB of the SRAM can be retained in increments of 8 KB. 8 KB of data SRAM is always retained.

Users can additionally retain

- 16 KB out of 32 KB of instruction SRAM
- 8 KB out of 32 KB of data SRAM

MMRs (Peripheral Control and Status)

For the address space containing MMRs, refer to [Figure 2](#). These registers provide control and status for on-chip peripherals of the [ADuCM3027/ADuCM3029](#). For more information about the MMRs, refer to the [ADuCM302x Ultra Low Power ARM Cortex-M3 MCU with Integrated Power Management Hardware Reference](#).

Flash Memory

The [ADuCM3027/ADuCM3029](#) MCUs include 128 KB to 256 KB of embedded flash memory, which is accessed using a flash controller. For memory available on each product, see [Table 1](#). The flash controller is coupled with a cache controller. A prefetch mechanism is implemented in the flash controller to optimize code performance.

Flash writes are supported by a key hole mechanism via advanced peripheral bus (APB) writes to MMRs. The flash controller provides support for DMA-based key hole writes.

With respect to flash integrity, the devices support the following:

- A fixed user key required for running protected commands, including mass erase and page erase.
- An optional and user definable user failure analysis key (FAA key). Analog Devices personnel need this key while performing failure analysis.
- An optional and user definable write protection for user accessible memory.
- An optional 8-bit ECC. It is enabled by default. It is recommended not to disable ECC.

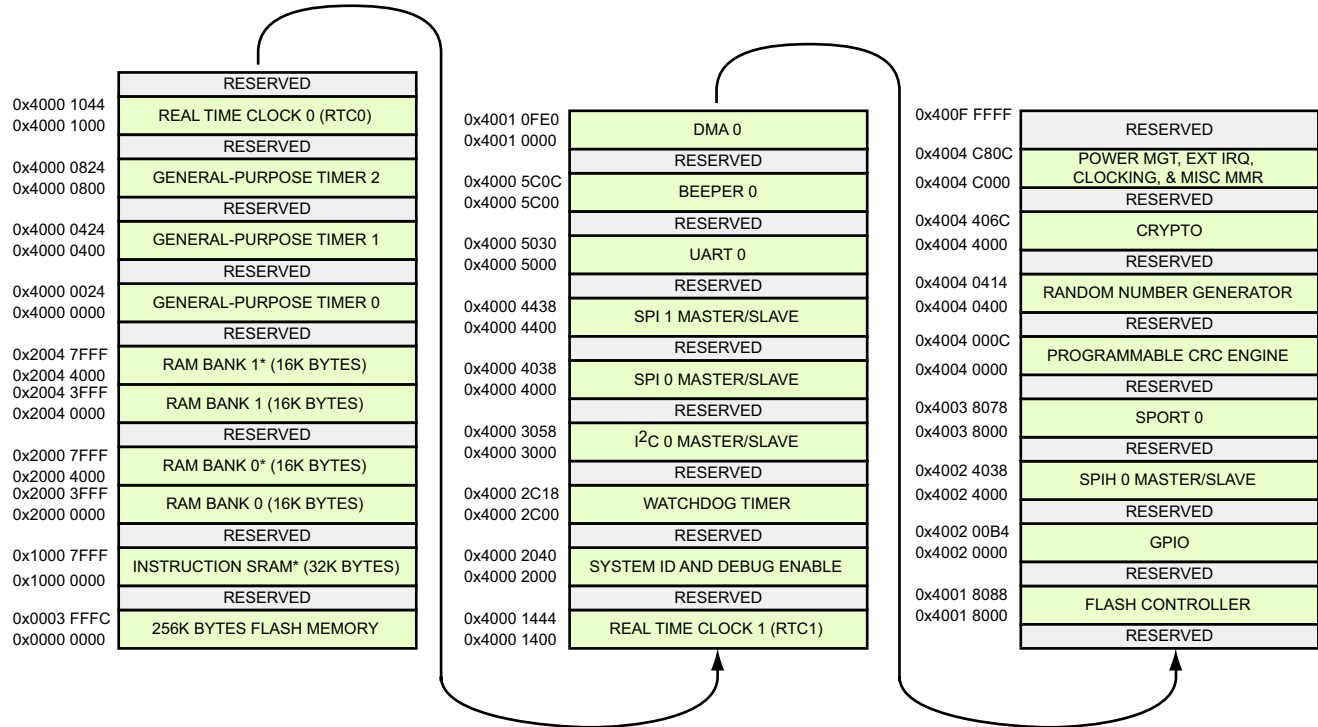

Figure 2. ADuCM3027/ADuCM3029 Memory Map

Cache Controller

The ADuCM3027/ADuCM3029 MCUs have an optional 4 KB instruction cache. In certain applications, enabling the cache and executing the code can result in lower power consumption than operating directly from flash. When the cache controller is enabled, 4 KB of instruction SRAM is reserved as cache memory. In hibernate mode, the cache memory is not retained.

SYSTEM AND INTEGRATION FEATURES

The ADuCM3027/ADuCM3029 MCUs provide several features that ease system integration.

Reset

There are four types of resets: external, power-on, watchdog timeout, and software system reset. The software system reset is provided as part of the Cortex-M3 core.

The SYS_HWRST pin is toggled to perform a hardware reset.

Booting

The ADuCM3027/ADuCM3029 MCUs support two boot modes: booting from internal flash and upgrading software through UART download. If the SYS_BMODE0 pin (GPIO17) is pulled low during power-up or a hard reset, the MCU enters into serial download mode.

In this mode, an on-chip loader routine initiates in the kernel, which configures the UART port and communicates with the host to manage the firmware upgrade via a specific serial download protocol.

Table 2. Boot Modes

Boot Mode	Description
0	UART download mode.
1	Flash boot. Boot from integrated flash memory.

Power Management

The ADuCM3027/ADuCM3029 MCUs have an integrated power management system that optimizes performance and extends battery life of the devices.

The power management system consists of the following:

- Integrated 1.2 V low dropout regulator (LDO) and optional capacitive buck regulator
- Integrated power switches for low standby current in hibernate and shutdown modes

ADuCM3027/ADuCM3029

Additional power management features include the following:

- Customized clock gating for active and Flexi modes
- Power gating to reduce leakage in hibernate and shutdown modes
- Flexible sleep modes
- Shutdown mode with no retention
- Optional high efficiency buck converter to reduce power
- Integrated low power oscillators

Power Modes

The PMU provides control of the [ADuCM3027/ADuCM3029](#) power modes and allows the ARM Cortex-M3 to control the clocks and power gating to reduce the power consumption.

Several power modes are available. Each mode provides an additional low power benefit with a corresponding reduction in functionality.

- Active mode. All peripherals can be enabled. Active power is managed by optimized clock management. See [Table 4](#) for details on active mode power.
- Flexi mode. The ARM Cortex-M3 core is clock gated, but the remainder of the system is active. No instructions can be executed in this mode, but DMA transfers can continue between peripherals and memory as well as memory to memory. See [Table 5](#) for details on Flexi mode power.
- Hibernate mode. This mode provides state retention, configurable SRAM and port pin retention, a limited number of wake-up interrupts (XINT0_WAKEn and UART0_RX), and, optionally, two RTCs—RTC0 and RTC1 (FLEX_RTC).
- Shutdown mode. This mode is the deepest sleep mode, in which all the digital and analog circuits are powered down with an option to wake from four possible wake-up sources: three external interrupts and RTC0. The RTC0 can be optionally enabled in this mode and the device can be periodically woken up by the RTC0 interrupt. See [Table 6](#) for deep sleep (hibernate and shutdown) mode specifications.

The following features are available for power management and control:

- A voltage range of 1.74 V to 3.6 V, using a single supply (such as the CR2032 coin cell battery).
- GPIOs are driven directly from the battery. The pin state is retained in hibernate and shutdown modes. The GPIO configuration is only retained in hibernate mode.
- Wake-up from external interrupt (via GPIOs), UART0_RX interrupt, and RTCs for hibernate mode.
- Wake-up from external interrupt (via GPIOs) and RTC0 for shutdown mode.
- Optional high power buck converter for 1.2 V full on support; for MCU usage only. See [Figure 3](#) for the suggested external circuitry.

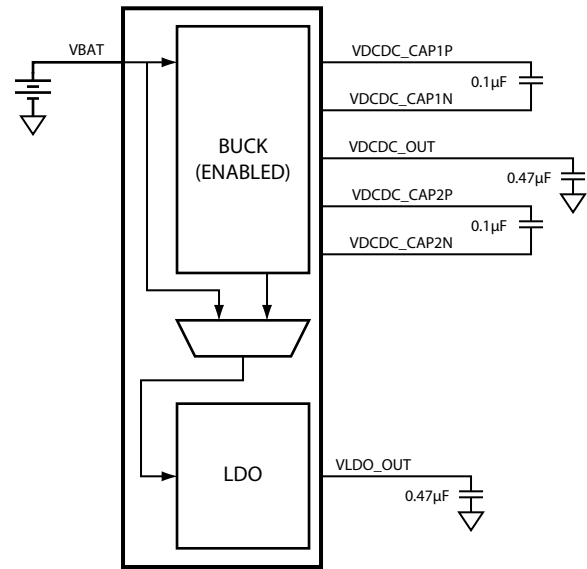

Note: For designs in which the optional buck is not used, the following pins must be left unconnected—VDCDC_CAP1P, VDCDC_CAP1N, VDCDC_OUT, VDCDC_CAP2P, and VDCDC_CAP2N.

Figure 3. Buck Enabled Design

Security Features

The [ADuCM3027/ADuCM3029](#) MCUs provide a combination of hardware and software protection mechanisms that lock out access to the devices in secure mode, but grant access in open mode. These mechanisms include password protected slave boot mode (UART), as well as password protected serial wire debug (SWD) interfaces.

Mechanisms are provided to protect the device contents (flash, SRAM, CPU registers, and peripheral registers) from being read through an external interface by an unauthorized user. This is referred to as read protection.

It is possible to protect the device from being reprogrammed in circuit with unauthorized code. This is referred to as in circuit write protection.



CAUTION

This product includes security features that can be used to protect embedded nonvolatile memory contents and prevent execution of unauthorized code. When security is enabled on this device (either by the ordering party or the subsequent receiving parties), the ability of Analog Devices to conduct failure analysis on returned devices is limited. Contact Analog Devices for details on the failure analysis limitations for this device.

The devices can be configured with no protection, read protection, or read and in circuit write protection. It is not necessary to provide in circuit write protection without read protection.

Cryptographic Accelerator

The cryptographic accelerator is a 32-bit APB DMA capable peripheral. There are two 32-bit buffers provided for data input/output operations. These buffers read in or read out 128 bits in four data accesses. Big endian and little endian data formats are supported, as are the following modes:

- Electronic code book (ECB) mode—AES mode
- Counter (CTR) mode
- Cipher block chaining (CBC) mode
- Message authentication code (MAC) mode
- Cipher block chaining-message authentication code (CCM/CCM*) mode
- SHA-256 modes

True Random Number Generator (TRNG)

The TRNG is used during operations where nondeterministic values are required. This can include generating challenges for secure communication or keys for an encrypted communication channel. The generator can run multiple times to generate a sufficient number of bits for the strength of the intended operation. The TRNG can seed a deterministic random bit generator.

Reliability and Robustness Features

The ADuCM3027/ADuCM3029 MCUs provide a number of features that can enhance or help achieve certain levels of system safety and reliability. While the level of safety is mainly dominated by system considerations, the following features are provided to enhance robustness:

- ECC enabled flash memory. The entire flash array can be protected to either correct single-bit errors or detect two-bit errors per 64-bit flash data (enabled by default).
- Multiparity bit protected SRAM. Each word of the SRAM and cache memory is protected by multiple parity bits to allow detection of random soft errors.
- Software watchdog. The on-chip watchdog timer can provide software-based supervision of the ADuCM3027/ADuCM3029.

Cyclic Redundancy Check (CRC) Accelerator

The CRC accelerator computes the CRC for a block of memory locations. The exact memory location can be in the SRAM, flash, or any combination of MMRs. The CRC accelerator generates a checksum that can be compared with an expected signature.

The main features of the CRC include the following:

- Generates a CRC signature for a block of data.
- Supports programmable polynomial length of up to 32 bits.
- Operates on 32 bits of data at a time.
- Supports MSB first and LSB first CRC implementations.
- Various data mirroring capabilities.

- Initial seed to be programmed by user.
- DMA controller (memory to memory transfer) used for data transfer to offload the MCU.

Programmable GPIOs

The ADuCM3027/ADuCM3029 MCUs have 44 and 36 GPIO pins in the LFCSP and WLCSP packages, respectively, with multiple, configurable functions defined by user code. They can be configured as an input/output and have programmable pull-up resistors. All GPIO pins are functional over the full supply range.

In deep sleep mode, GPIO pins retain their state. On reset, they tristate.

Timers

The ADuCM3027/ADuCM3029 MCUs have three general-purpose timers and a watchdog timer.

General-Purpose Timers

The ADuCM3027/ADuCM3029 MCUs have three identical general-purpose timers, each with a 16-bit up and down counter. The up and down counter can be clocked from one of four user selectable clock sources. Any selected clock source can be scaled down using a prescaler of 1, 16, 64, or 256.

Watchdog Timer (WDT)

The WDT is a 16-bit count down timer with a programmable prescaler. The prescaler source is selectable and can be scaled by a factor of 1, 16, or 256. The watchdog timer is clocked by the 32 kHz on-chip oscillator (LFOSC) and recovers from an illegal software state. The WDT requires periodic servicing to prevent it from forcing a reset or interrupt to the MCU.

Analog-to-Digital Converter (ADC) Subsystem

The ADuCM3027/ADuCM3029 MCUs integrate a 12-bit SAR ADC with up to eight external channels. Conversions can be performed in single or autcycle mode. In single mode, the ADC can be configured to convert on a particular channel by selecting one of the channels. Autocycle mode is provided to reduce MCU overhead of sampling and reading individual channel registers. The ADC can also be used for temperature sensing and measuring battery voltage using dedicated channels. Temperature sensing and battery monitoring cannot be included with external channels in autocycle mode.

A digital comparator triggers an interrupt if ADC input is above or below a programmable threshold. The ADC0_VIN0, ADC0_VIN1, ADC0_VIN2, and ADC0_VIN3 input channels can be used with the digital comparator.

Use the ADC in DMA mode to reduce MCU overhead by moving ADC results directly into SRAM with a single interrupt asserted when the required number of ADC conversions has been completely logged to memory.

ADuCM3027/ADuCM3029

The main features of the ADC subsystem include the following:

- 12-bit resolution.
- Programmable ADC update rate from 10 KSPS to 1.8 MSPS.
- Integrated input multiplexer that supports up to eight channels.
- Temperature sensing support.
- Battery monitoring support.
- Software selectable on-chip reference voltage generation—1.25 V and 2.5 V.
- Software selectable internal or external reference.
- Autocycle mode—ability to automatically select a sequence of input channels for conversion.
- Averaging function—converted data on single or multiple channels can be averaged up to 256 samples.
- Alert function—internal digital comparator for ADC0_VIN0, ADC0_VIN1, ADC0_VIN2, and ADC0_VIN3 channels. An interrupt is generated if the digital comparator detects an ADC result above or below a user defined threshold.
- Dedicated DMA channel support.
- Each channel, including temperature sensor and battery monitoring, has a data register for conversion result.

Clocking

The [ADuCM3027/ADuCM3029](#) MCUs have the following clocking options:

- 26 MHz
 - Internal oscillator—HFOSC (26 MHz)
 - External crystal oscillator—HFXTAL (26 MHz or 16 MHz)
 - GPIO clock in—SYS_CLKIN
- 32 kHz
 - Internal oscillator—LFOSC
 - External crystal oscillator—LFXTAL

The clock options have software configurability with the following exceptions:

- HFOSC cannot be disabled when using an internal buck regulator.
- LFOSC cannot be disabled even if using LFXTAL.

Real-Time Clock (RTC)

The [ADuCM3027/ADuCM3029](#) MCUs have two real-time clock blocks—RTC0 and RTC1 (FLEX_RTC). The clock blocks share a low power crystal oscillation circuit that operates in conjunction with a 32,768 Hz external crystal.

The RTC has an alarm that interrupts the core when the programmed alarm value matches the RTC count. The software enables and configures the RTC.

The RTC also has a digital trim capability to allow a positive or negative adjustment to the RTC count at fixed intervals.

The FLEX_RTC supports SensorStrobe mechanism. Using this mechanism, the [ADuCM3027/ADuCM3029](#) MCUs can be used as a programmable clock generator in some power modes, including hibernate mode. In this way, the external sensors can have their timing domains mastered by the [ADuCM3027/ADuCM3029](#) MCUs, as SensorStrobe can output a programmable divider from the FLEX_RTC, which can operate up to a resolution of 30.7 μ s. The sensors and MCU are in sync, which removes the need for additional resampling of data to time align it.

In the absence of this mechanism,

- The external sensor uses an RC oscillator ($\sim\pm 30\%$ typical variation). The MCU must sample the data and resample it on the time domain of the MCU before using it.

Or

- The MCU remains in a higher power state and drives each data conversion on the sensor side.

This mechanism allows the [ADuCM3027/ADuCM3029](#) MCUs to be in a lower power state for a long duration and avoids unnecessary data processing which extends the battery life of the end product.

The key differences between RTC0 and RTC1 (FLEX_RTC) are shown in [Table 3](#).

Table 3. RTC Features

Features	RTC0	RTC1 (FLEX_RTC)
Resolution of Time Base (Prescaling)	Counts time at 1 Hz in units of seconds. Operationally, always prescales to 1 Hz (for example, divide by 32,768) and always counts real time in units of seconds.	Can prescale the clock by any power of two from 0 to 15. It can count time in units of any of these 16 possible prescale settings. For example, the clock can be prescaled by 1, 2, 4, 8, ..., 16384, or 32768.
Source Clock	LFXTAL.	Depending on the low frequency multiplexer (LFMUX) configuration, the RTC is clocked by the LFXTAL or the LFOSC.
Wake-Up Timer	Wake-up time is specified in units of seconds.	Supports alarm times down to a resolution of 30.7 μ s, that is, where the time is specified down to a specific 32 kHz clock cycle.
Number of Alarms	One alarm only. Uses an absolute, nonrepeating alarm time, specified in units of 1 sec.	Two alarms. One absolute alarm time and one periodic alarm, repeating every 60 prescaled time units.
SensorStrobe Mechanism	Not available.	SensorStrobe is an alarm mechanism in the RTC that causes an output pulse to be sent via GPIOs to an external device to instruct the device to take a measurement or perform some action at a specific time. SensorStrobe events are scheduled at a specific target time relative to the real-time count of the RTC. SensorStrobe can be enabled in active, Flexi, and hibernate modes.
Input Capture	Not available.	Input capture takes a snapshot of the RTC when an external device signals an event via a transition on one of the GPIO inputs to the ADuCM3027/ ADuCM3029 . Typically, an input-capture event is triggered by an autonomous measurement or action on such a device, which then signals to the ADuCM3027/ ADuCM3029 that the RTC must take a snapshot of time corresponding to the event. Taking the snapshot can wake up the ADuCM3027/ ADuCM3029 and cause an interrupt to the CPU. The CPU can subsequently obtain information from the RTC on the exact 32 kHz cycle on which the input capture event occurred.

ADuCM3027/ADuCM3029

Beeper Driver

The [ADuCM3027/ADuCM3029](#) MCUs have an integrated audio driver for a beeper.

The beeper driver module in the [ADuCM3027/ADuCM3029](#) MCUs generate a differential square wave of programmable frequency. It drives an external piezoelectric sound component with two terminals that connect to the differential square wave output.

The beeper driver consists of a module that can deliver frequencies ranging from 8 kHz to ~0.25 kHz. It operates on a fixed independent 32 kHz clock source that is unaffected by changes in system clocks.

It allows programmable tone durations from 4 ms to 1.02 sec in 4 ms increments. Pulse (single-tone) and sequence (multitone) modes provide versatile playback options.

In sequence mode, the beeper can be programmed to play any number of tone pairs from 1 to 254 (2 to 508 tones) or be programmed to play forever (until stopped by the user). Interrupts are available to indicate the start or end of any beep, the end of a sequence, or when the sequence is nearing completion.

Debug Capability

The [ADuCM3027/ADuCM3029](#) MCUs support SWD.

ON-CHIP PERIPHERAL FEATURES

The [ADuCM3027/ADuCM3029](#) MCUs have a rich set of peripherals connected to the core via several concurrent high bandwidth buses, providing flexibility in system configuration as well as excellent overall system performance (see [Figure 1](#)).

The [ADuCM3027/ADuCM3029](#) MCUs contain high speed serial ports, an interrupt controller for flexible management of interrupts from the on-chip peripherals or external sources, and power management control functions to tailor the performance and power characteristics of the MCU and system to many application scenarios.

Serial Ports (SPORT)

The [ADuCM3027/ADuCM3029](#) MCUs provide two single direction half SPORTs or one bidirectional full SPORT. The synchronous serial ports provide an inexpensive interface to a wide variety of digital and mixed-signal peripheral devices such as Analog Devices audio codecs, ADCs, and DACs. The serial ports contain two data lines, a clock, and a frame sync. The data lines can be programmed to either transmit or receive, and each data line has a dedicated DMA channel.

Serial port data can be automatically transferred to and from on-chip memory or external memory via dedicated DMA channels. The frame sync and clock can be shared. Some of the ADCs and DACs require two control signals for their conversion process. To interface with such devices, the SPT0_ACNV and SPT0_BCNV signals are provided. To use these signals, enable the timer enable mode. In this mode, a PWM timer inside the module generates the programmable SPT0_ACNV and SPT0_BCNV signals.

Serial ports operate in two modes:

- Standard digital signal processor (DSP) serial mode
- Timer enable mode

Serial Peripheral Interface (SPI) Ports

The [ADuCM3027/ADuCM3029](#) MCUs provide three SPIs. SPI is an industry standard, full-duplex, synchronous serial interface that allows eight bits of data to be synchronously transmitted and simultaneously received. Each SPI incorporates two DMA channels that interface with the DMA controller. One DMA channel transmits and the other receives. The SPI on the MCU eases interfacing to external serial flash devices.

The SPI features include the following:

- Serial clock phase mode and serial clock polarity mode
- Loopback mode
- Continuous and repeated transfer mode
- Wired OR output mode
- Read command mode for half-duplex operation (transmit followed by receive)
- Flow control support in read command mode
- Support for 3-pin SPI in read command mode
- Multiple \overline{CS} line support
- \overline{CS} software override support

UART Port

The [ADuCM3027/ADuCM3029](#) MCUs provide a full-duplex UART port, which is fully compatible with PC standard UARTs. The UART port provides a simplified UART interface to other peripherals or hosts, supporting full-duplex, DMA, and asynchronous transfers of serial data. The UART port includes support for five to eight data bits, and none, even, or odd parity. A frame is terminated by one, one and a half, or two stop bits.

I²C

The [ADuCM3027/ADuCM3029](#) MCUs provide an I²C bus peripheral that has two pins for data transfer. SCL is a serial clock pin and SDA is a serial data pin. The pins are configured in a wired AND format that allows arbitration in a multimaster system. A master device can be configured to generate the serial clock. The frequency is programmed by the user in the serial clock divisor register. The master channel can operate in fast mode (400 kHz) or standard mode (100 kHz).

DEVELOPMENT SUPPORT

Development support for the [ADuCM3027/ADuCM3029](#) MCUs includes documentation, evaluation hardware, and development software tools.

Documentation

The [ADuCM302x Ultra Low Power ARM Cortex-M3 MCU with Integrated Power Management Hardware Reference](#) details the functionality of each block on the [ADuCM3027/ADuCM3029](#) MCUs. It includes power management, clocking, memories, and peripherals.

Hardware

The [ADuCM3029 EZ-KIT](#)[®] is available to prototype sensor configurations with the [ADuCM3027/ADuCM3029](#) MCUs.

Software

The [ADuCM3029 EZ-KIT](#) includes a complete development and debug environment for the [ADuCM3027/ADuCM3029](#) MCUs. The board support package (BSP) for the [ADuCM3027/ADuCM3029](#) is provided for the IAR Embedded Workbench for ARM, Keil™, and CrossCore[®] embedded studio (CCES) environments.

The BSP also includes operating system (OS) aware drivers and example code for all the peripherals on the devices.

ADDITIONAL INFORMATION

The following publications that describe the [ADuCM3027/ADuCM3029](#) MCUs can be ordered from any Analog Devices sales office or accessed electronically on the Analog Devices website:

- [ADuCM302x Ultra Low Power ARM Cortex-M3 MCU with Integrated Power Management Hardware Reference.](#)
- [ADuCM3027/ADuCM3029 Anomaly List](#)

This data sheet describes the ARM Cortex-M3 core and memory architecture used on the [ADuCM3027/ADuCM3029](#) MCUs, but does not provide detailed programming information for the ARM processor. For more information about programming the ARM processor, visit the ARM Infocenter web page.

The applicable documentation for programming the ARM Cortex-M3 processor include the following:

- *ARM Cortex-M3 Devices Generic User Guide*
- *ARM Cortex-M3 Technical Reference Manual*

REFERENCE DESIGNS

The [Circuits from the Lab](#)[®] page provides the following:

- Graphical circuit block diagram presentation of signal chains for a variety of circuit types and applications
- Drill down links for components in each chain to selection guides and application information
- Reference designs applying best practice design techniques

SECURITY FEATURES DISCLAIMER

To our knowledge, the Security Features, when used in accordance with the data sheet and hardware reference manual specifications, provide a secure method of implementing code and data safeguards. However, Analog Devices does not guarantee that this technology provides absolute security. ACCORDINGLY, ANALOG DEVICES HEREBY DISCLAIMS ANY AND ALL EXPRESS AND IMPLIED WARRANTIES THAT THE SECURITY FEATURES CANNOT BE BREACHED, COMPROMISED, OR OTHERWISE CIRCUMVENTED AND IN NO EVENT SHALL ANALOG DEVICES BE LIABLE FOR ANY LOSS, DAMAGE, DESTRUCTION, OR RELEASE OF DATA, INFORMATION, PHYSICAL PROPERTY, OR INTELLECTUAL PROPERTY.

ADuCM3027/ADuCM3029

SPECIFICATIONS

For information about product specifications, contact your Analog Devices, Inc. representative.

OPERATING CONDITIONS

Parameter	Conditions	Min	Typ	Max	Unit
$V_{BAT}^{1, 2}$	External Battery Supply Voltage	1.74	3.0	3.6	V
V_{IH}	High Level Input Voltage	$V_{BAT} = 3.6\text{ V}$	2.5		V
V_{IL}	Low Level Input Voltage	$V_{BAT} = 1.74\text{ V}$		0.45	V
V_{BAT_ADC}	ADC Supply Voltage	1.74	3.0	3.6	V
T_J	Junction Temperature	$T_{AMBIENT} = -40^{\circ}\text{C to } +85^{\circ}\text{C}$		+85	$^{\circ}\text{C}$

¹ The voltage must remain powered even if the associated function is not used.

² Value applies to the VBAT_ANA1, VBAT_ANA2, VBAT_DIG1, and VBAT_DIG2 pins.

ELECTRICAL CHARACTERISTICS

Parameter	Conditions	Min	Typ	Max	Unit
V_{OH}^1	High Level Output Voltage	$V_{BAT} = \text{minimum V, } I_{OH} = -1.0\text{ mA}$	1.4		V
V_{OL}^1	Low Level Output Voltage	$V_{BAT} = \text{minimum V, } I_{OL} = 1.0\text{ mA}$		0.4	V
I_{IHPU}^2	High Level Input Current Pull-Up	$V_{BAT} = \text{maximum V, } V_{IN} = \text{maximum } V_{BAT}$	0.01	1	μA
I_{ILPU}^2	Low Level Input Current Pull-Up	$V_{BAT} = \text{maximum V, } V_{IN} = 0\text{ V}$		100	μA
I_{OZH}^3	Three-State Leakage Current	$V_{BAT} = \text{maximum V, } V_{IN} = \text{maximum } V_{BAT}$	0.01	1	μA
I_{OZL}^3	Three-State Leakage Current	$V_{BAT} = \text{maximum V, } V_{IN} = 0\text{ V}$	0.01	1	μA
I_{OZLPU}^4	Three-State Leakage Current Pull-Up	$V_{BAT} = \text{maximum V, } V_{IN} = 0\text{ V}$		100	μA
I_{OZHPU}^4	Three-State Leakage Current Pull-Up	$V_{BAT} = \text{maximum V, } V_{IN} = \text{maximum } V_{BAT}$		1	μA
I_{OZLPD}^5	Three-State Leakage Current Pull-Down	$V_{BAT} = \text{maximum V, } V_{IN} = 0\text{ V}$		1	μA
I_{OZHDPD}^5	Three-State Leakage Current Pull-Down	$V_{BAT} = \text{maximum V, } V_{IN} = \text{maximum } V_{BAT}$		100	μA
C_{IN}	Input Capacitance	$T_J = 25^{\circ}\text{C}$	10		pF

¹ Applies to the output and bidirectional pins: P1_10, P0_10, P0_11, P1_02, P1_03, P1_04, P1_05, P2_01, P0_13, P0_15, P1_00, P1_01, P1_15, P2_00, P0_12, P2_11, P1_06, P1_07, P1_08, P1_09, P0_00, P0_01, P0_02, P0_03, P0_06, P0_07, P2_03, P2_04, P2_05, P2_06, P2_07, P2_08, P2_09, P2_10, P0_04, P0_05, P0_14, P2_02, P1_14, P1_13, P1_12, P1_11, P0_08, and P0_09.

² Applies to the input pin with pull-up: $\overline{\text{SYS_HWRST}}$.

³ Applies to the three-statable pins: P1_10, P0_10, P0_11, P1_02, P1_03, P1_04, P1_05, P2_01, P0_13, P0_15, P1_00, P1_15, P2_00, P0_12, P2_11, P1_06, P1_07, P1_08, P1_09, P0_00, P0_01, P0_02, P0_03, P2_03, P2_04, P2_05, P2_06, P2_07, P2_08, P2_09, P2_10, P0_04, P0_05, P0_14, P2_02, P1_14, P1_13, P1_12, P1_11, P0_08, and P0_09.

⁴ Applies to the three-statable pins with pull-ups: P1_10, P0_10, P0_11, P1_02, P1_03, P1_04, P1_05, P2_01, P0_13, P0_15, P1_00, P1_15, P2_00, P0_12, P2_11, P1_06, P1_07, P1_08, P1_09, P0_00, P0_01, P0_02, P0_03, P2_03, P2_04, P2_05, P2_06, P2_07, P2_08, P2_09, P2_10, P0_04, P0_05, P0_14, P2_02, P1_14, P1_13, P1_12, P1_11, P0_08, P0_09, P0_07, and P1_01.

⁵ Applies to the three-statable pin with pull-down: P0_06.

Power Supply Current

Table 4, Table 5, and Table 6 describe power supply current for V_{BAT} .

Table 4. Active Mode—Current Consumption When $V_{BAT} = 3.0$ V

Conditions	Buck	Typ ¹	Max ²	Unit
Code ³ executing from flash, cache enabled, peripheral clocks off, HCLK = 6.5 MHz	Enabled	0.40		mA
Code ³ executing from flash, cache enabled, peripheral clocks off, HCLK = 26 MHz	Enabled	0.98	1.29	mA
	Disabled	1.75	2.38	mA
Code ³ executing from flash, cache disabled, peripheral clocks off, HCLK = 26 MHz	Enabled	1.28	1.64	mA
	Disabled	2.34	3.0	mA
Code ³ executing from SRAM, peripheral clocks off, HCLK = 26 MHz	Enabled	0.95	1.36	mA
	Disabled	1.78	2.48	mA
Code ³ executing from flash, cache enabled, peripheral clocks on, HCLK = 26 MHz, PCLK = 26 MHz	Enabled	1.08	1.43	mA
	Disabled	1.99	2.67	mA
Code ³ executing from flash, cache disabled, peripheral clocks on, HCLK = 26 MHz, PCLK = 26 MHz	Enabled	1.37	1.78	mA
	Disabled	2.55	3.29	mA
Code ³ executing from SRAM, peripheral clocks on, HCLK = 26 MHz, PCLK = 26 MHz	Enabled	1.08	1.49	mA
	Disabled	2.03	2.74	mA

¹ $T_J = 25^\circ\text{C}$.

² $T_J = 85^\circ\text{C}$.

³ The code being executed is a prime number generation in a continuous loop, with HFOSC as the system clock source.

Table 5. Flexi™ Mode—Current Consumption When $V_{BAT} = 3.0$ V

Conditions	Buck	Typ ¹	Max ²	Unit
Peripheral clocks off	Enabled	0.3	0.67	mA
	Disabled	0.52	1.11	mA
Peripheral clocks on, PCLK = 26 MHz	Enabled	0.39	0.80	mA
	Disabled	0.7	1.38	mA

¹ $T_J = 25^\circ\text{C}$.

² $T_J = 85^\circ\text{C}$.

Table 6. Deep Sleep Modes¹—Current Consumption When $V_{BAT} = 3.0$ V

Mode	Conditions	-40°C	+25°C	+85°C	+85°C	Unit
		Typ	Typ	Typ	Max	
Hibernate	RTC1 and RTC0 disabled, 8 KB SRAM retained, LFXTAL off	0.66	0.75	2.0	6.05	μA
	RTC1 and RTC0 disabled, 16 KB SRAM retained, LFXTAL off	0.67	0.77	2.4	6.4	μA
	RTC1 and RTC0 disabled, 24 KB SRAM retained, LFXTAL off	0.68	0.79	2.6	6.75	μA
	RTC1 and RTC0 disabled, 32 KB SRAM retained, LFXTAL off	0.69	0.81	3.0	7.1	μA
	RTC1 enabled, 8 KB SRAM retained, LFOOSC as source for RTC1	0.69	0.78	2.05	6.1	μA
	RTC1 enabled, 8 KB SRAM retained, LFXTAL as source for RTC1	0.74	0.83	2.1	6.15	μA
	RTC1 and RTC0 enabled, 8 KB SRAM retained, LFXTAL as source for RTC1 and RTC0	0.83	0.93	2.25	6.3	μA
Shutdown	RTC0 enabled, LFXTAL as source for RTC0	290	310	490	1180	nA
	RTC0 disabled	40	56	260	950	nA

¹ Buck enable/disable selection does not affect power consumption.

ADuCM3027/ADuCM3029

SYSTEM CLOCKS/TIMERS

Table 7 and Table 8 show the system clock specifications for the ADuCM3027/ADuCM3029 MCUs.

Platform External Crystal Oscillator

Table 7. Platform External Crystal Oscillator Specifications

Parameter	Min	Typ	Max	Unit	Conditions
LOW FREQUENCY EXTERNAL CRYSTAL OSCILLATOR (LFXTAL) $C_{EXT1} = C_{EXT2}$	6		10	pF	External capacitor, $C_{EXT1} = C_{EXT2}$ (symmetrical load), for $C_L \leq 5$ pF (maximum) and $ESR = 30$ k Ω (maximum). C_{EXT1} , C_{EXT2} must be selected considering the printed circuit board (PCB) trace capacitance due to routing.
Frequency		32,768		Hz	
HIGH FREQUENCY EXTERNAL CRYSTAL OSCILLATOR (HFXTAL) $C_{EXT1} = C_{EXT2}$			20	pF	External capacitor, $C_{EXT1} = C_{EXT2}$ (symmetrical load), for $C_L = 10$ pF (maximum) and $ESR = 50$ Ω (maximum). C_{EXT1} , C_{EXT2} must be selected considering the PCB trace capacitance due to routing.
Frequency		26		MHz	

On-Chip RC Oscillator

Table 8. On-Chip RC Oscillator Specifications

Parameter	Min	Typ	Max	Unit	Conditions
HIGH FREQUENCY RC OSCILLATOR (HFOSC) Frequency	25.09	26	26.728	MHz	
LOW FREQUENCY RC OSCILLATOR (LFOSC) Frequency	30,800	32,768	34,407	Hz	

ADC SPECIFICATIONS

Table 9. ADC Specifications

Parameter ^{1,2}	VBAT/VREF (V)	Package	Typ	Unit	Conditions
NO MISSING CODE	1.8/1.25 (internal/external)	64-lead LFCSP	12	Bits	F _{in} = 1068 Hz, F _s = 100 KSPS, internal reference in low power mode, 400,000 samples end point method used
	1.8/1.25 (internal/external)	54-ball WLCSP	12	Bits	
	3.0/2.5 (internal/external)	64-lead LFCSP	12	Bits	
INTEGRAL NONLINEARITY ERROR	1.8/1.25 (internal/external)	64-lead LFCSP	±1.6	LSB	
	1.8/1.25 (internal/external)	54-ball WLCSP	±1.8	LSB	
	3.0/2.5 (internal/external)	64-lead LFCSP	±1.4	LSB	
DIFFERENTIAL NONLINEARITY ERROR	1.8/1.25 (internal/external)	64-lead LFCSP	−0.7, +1.15	LSB	
	1.8/1.25 (internal/external)	54-ball WLCSP	−0.75, +1.2	LSB	
	3.0/2.5 (internal/external)	64-lead LFCSP	−0.7, +1.1	LSB	
OFFSET ERROR	1.8/1.25 (external)	64-lead LFCSP	±0.5	LSB	
	1.8/1.25 (external)	54-ball WLCSP	±0.5	LSB	
	3.0/2.5 (external)	64-lead LFCSP	±0.5	LSB	
GAIN ERROR	1.8/1.25 (external)	64-lead LFCSP	±2.5	LSB	
	1.8/1.25 (external)	54-ball WLCSP	±3.0	LSB	
	3.0/2.5 (external)	64-lead LFCSP	±0.5	LSB	
I _{VBAT_ADC} ³	1.8/1.25 (internal)	64-lead LFCSP	104	μA	
	1.8/1.25 (internal)	54-ball WLCSP	108	μA	
	3.0/2.5 (internal)	64-lead LFCSP	131	μA	

¹The ADC is characterized in standalone mode without core activity and minimal or no switching on the adjacent ADC channels and digital inputs/outputs.

²The specifications are characterized after performing internal ADC offset calibration.

³Current consumption from VBAT_ADC supply when ADC is performing the conversion.

FLASH SPECIFICATIONS

Table 10. Flash Specifications

Parameter	Min	Typ	Max	Unit	Conditions
FLASH					
Endurance	10,000			Cycles	
Data Retention		10		Years	

ADuCM3027/ADuCM3029

ABSOLUTE MAXIMUM RATINGS

Stresses at or above those listed in [Table 11](#) may cause permanent damage to the product. This is a stress rating only. The functional operation of the product at these or any other conditions above those indicated in the operational section of this specification is not implied. Operation beyond the maximum operating conditions for extended periods may affect product reliability.

Table 11. Absolute Maximum Ratings

Parameter	Rating	Unit
SUPPLY		
VBAT_ANA1 VBAT_ANA2 VBAT_ADC VBAT_DIG1 VBAT_DIG2 VREF_ADC	-0.3 to +3.6	V
ANALOG		
VDCDC_CAP1N VDCDC_AP1P VDCDC_OUT VDCDC_CAP2N VDCDC_CAP2P	-0.3 to +3.6	V
VLDO_OUT SYS_HFXTAL_IN SYS_HFXTAL_OUT SYS_LFXTAL_IN SYS_LFXTAL_OUT	-0.3 to +1.32	V
DIGITAL INPUT/OUTPUT		
P0.X P1.X P2.X SYS_HWRST	-0.3 to +3.6	V

ESD SENSITIVITY



ESD (electrostatic discharge) sensitive device.

Charged devices and circuit boards can discharge without detection. Although this product features patented or proprietary protection circuitry, damage may occur on devices subjected to high energy ESD. Therefore, proper ESD precautions should be taken to avoid performance degradation or loss of functionality.

PACKAGE INFORMATION

[Figure 4](#) and [Table 12](#) provide details about package branding. For a complete listing of product availability, see the [Ordering Guide](#) section.



Figure 4. Product Information on Package¹

¹ Exact brand may differ, depending on package type.

Table 12. Package Brand Information

Brand Key	Field Description
ADuCM3027/ADuCM3029	Product model
t	Temperature range
pp	Package type
Z	RoHS compliant designation
ccc	See the Ordering Guide section
vvvvv.x	Assembly lot code
n.n	Silicon revision
yyww	Date code

TIMING SPECIFICATIONS

Specifications are subject to change without notice.

Reset Timing

Table 13 and Figure 5 describe reset timing.

Table 13. Reset Timing

Parameter	Min	Max	Unit
TIMING REQUIREMENTS			
t_{WRST} $\overline{\text{SYS_HWRST}}$ Asserted Pulse Width Low ¹	4		μs

¹ Applies after power-up sequence is complete.

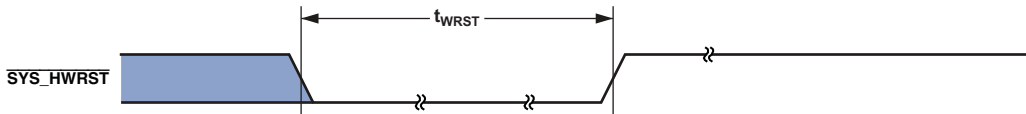

Figure 5. Reset Timing

System Clock and PLL

Table 14 describes system clock and phase-locked loop (PLL) specifications.

Table 14. System Clock and PLL

Parameter	Min	Max	Unit
TIMING REQUIREMENTS			
t_{CK} PLL Input CLKIN Period ¹	38.5	62.5	ns
f_{PLL} PLL Output Frequency ^{2, 3}	16	60	MHz
t_{PCLK} System Peripheral Clock Period	38.5	154	ns
t_{HCLK} Advanced High Performance Bus (AHB) Subsystem Clock Period	38.5	154	ns

¹ The input to the PLL can come either from the high frequency external crystal or from the high frequency internal RC oscillator. Refer to the [ADuCM302x Ultra Low Power ARM Cortex-M3 MCU with Integrated Power Management Hardware Reference](#).

² For the minimum value, the recommended settings are PLL_MSEL = 13, PLL_NSEL = 16, and PLL_DIV2 = 1 for PLL input clock = 26 MHz; and PLL_MSEL = 13, PLL_NSEL = 26, and PLL_DIV2 = 1 for PLL input clock = 16 MHz.

³ For the maximum value, the recommended settings are PLL_MSEL = 13, PLL_NSEL = 30, and PLL_DIV2 = 0 for PLL input clock = 26 MHz; and PLL_MSEL = 8, PLL_NSEL = 30, and PLL_DIV2 = 0 for PLL input clock = 16 MHz.

ADuCM3027/ADuCM3029

Serial Ports

To determine whether communication is possible between two devices at a particular clock speed, confirm the following specifications:

- Frame sync delay and frame sync setup and hold
- Data delay and data setup and hold
- Serial clock (SPT_CLK) width

In [Figure 6](#), use the rising edge or the falling edge of SPT_CLK (external or internal) as the active sampling edge.

When externally generated, the SPORT clock is called $f_{SPTCLKEXT}$.

$$t_{SPTCLKEXT} = \frac{1}{f_{SPTCLKEXT}}$$

When internally generated, the programmed SPORT clock ($f_{SPTCLKPROG}$) frequency is set by the following equation:

$$f_{SPTCLKPROG} = \frac{f_{PCLK}}{2 \times (CLKDIV + 1)}$$

where CLKDIV is a field in the SPORT_DIV register that can be set from 0 to 65535.

Table 15. Serial Ports—External Clock

Parameter	Min	Max	Unit
TIMING REQUIREMENTS			
t_{SFSE} Frame Sync Setup Before SPT_CLK (Externally Generated Frame Sync in Transmit or Receive Mode) ¹	5		ns
t_{HFSE} Frame Sync Hold After SPT_CLK (Externally Generated Frame Sync in Transmit or Receive Mode) ¹	5		ns
t_{SDRE} Receive Data Setup Before Receive SPT_CLK ¹	5		ns
t_{HDRE} Receive Data Hold After SPT_CLK ¹	8		ns
t_{SCLKW} SPT_CLK Width ²	38.5		ns
t_{SPTCLK} SPT_CLK Period ²	77		ns
SWITCHING CHARACTERISTICS			
t_{DFSE} Frame Sync Delay After SPT_CLK (Internally Generated Frame Sync in Transmit or Receive Mode) ³		20	ns
t_{HOFSE} Frame Sync Hold After SPT_CLK (Internally Generated Frame Sync in Transmit or Receive Mode) ³	2		ns
t_{DDTE} Transmit Data Delay After Transmit SPT_CLK ³		20	ns
t_{HDTE} Transmit Data Hold After Transmit SPT_CLK ³	1		ns

¹ This specification is referenced to the sample edge.

² This specification indicates the minimum instantaneous width or period that can be tolerated due to duty cycle variation or jitter on the external SPT_CLK.

³ This specification is referenced to the drive edge.

Table 16. Serial Ports—Internal Clock

Parameter		Min	Max	Unit
TIMING REQUIREMENTS				
t_{SDRI}	Receive Data Setup Before SPT_CLK ¹	25		ns
t_{HDRI}	Receive Data Hold After SPT_CLK ¹	0		ns
SWITCHING CHARACTERISTICS				
t_{DFSI}	Frame Sync Delay After SPT_CLK (Internally Generated Frame Sync in Transmit or Receive Mode) ²		20	ns
t_{HOFSI}	Frame Sync Hold After SPT_CLK (Internally Generated Frame Sync in Transmit or Receive Mode) ²	-8		ns
t_{DDTI}	Transmit Data Delay After SPT_CLK ²		20	ns
t_{HDTI}	Transmit Data Hold After SPT_CLK ²	-7		ns
t_{SCLKIW}	SPT_CLK Width	$t_{PCLK} - 1.5$		ns
t_{SPTCLK}	SPT_CLK Period	$2 \times t_{PCLK} - 1$		ns

¹ This specification is referenced to the sample edge.

² This specification is referenced to the drive edge.

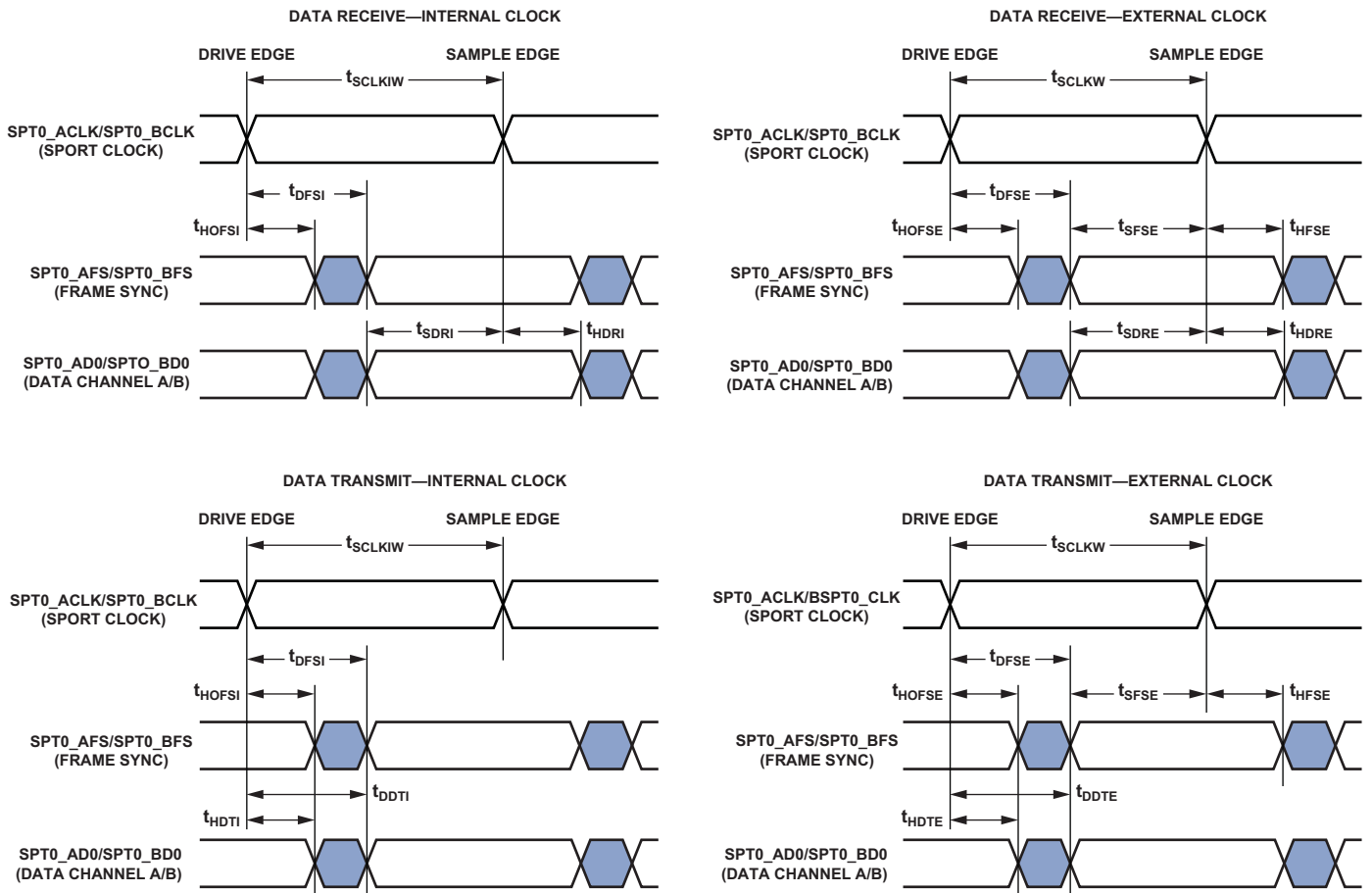

Figure 6. Serial Ports

ADuCM3027/ADuCM3029

Table 17. Serial Ports—Enable and Three-State

Parameter	Min	Max	Unit
SWITCHING CHARACTERISTICS			
t_{DDTIN} Data Enable From Internal Transmit SPT_CLK ¹	5		ns
t_{DDTI} Data Disable From Internal Transmit SPT_CLK ¹		160	ns

¹This specification is referenced to the drive edge.

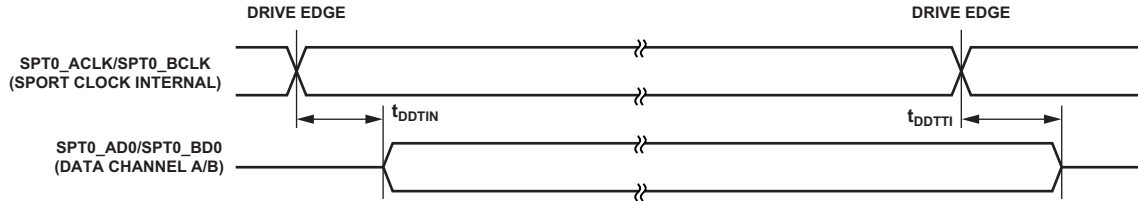

Figure 7. Serial Ports—Enable and Three-State

SPI Timing

Table 18, Figure 8, and Figure 9 (for master mode) and Table 19, Figure 10, and Figure 11 (for slave mode) describe SPI timing specifications. High speed SPI (SPIH) can be used for high data rate peripherals.

Table 18. SPI Master Mode Timing¹

Parameter		Min	Max	Unit
TIMING REQUIREMENTS				
t_{CS}	\overline{CS} to SCLK Edge	$0.5 \times t_{PCLK} - 3$		ns
t_{SL}	SCLK Low Pulse Width	$t_{PCLK} - 3.5$		ns
t_{SH}	SCLK High Pulse Width	$t_{PCLK} - 3.5$		ns
t_{DSU}	Data Input Setup Time Before SCLK Edge	5		ns
t_{DHD}	Data Input Hold Time After SCLK Edge	20		ns
SWITCHING CHARACTERISTICS				
t_{DAV}	Data Output Valid After SCLK Edge		25	ns
t_{DOSU}	Data Output Setup Before SCLK Edge	$t_{PCLK} - 2.2$		ns
t_{SFS}	\overline{CS} High After SCLK Edge	$0.5 \times t_{PCLK} - 3$		ns

¹This specification is characterized with respect to double drive strength.

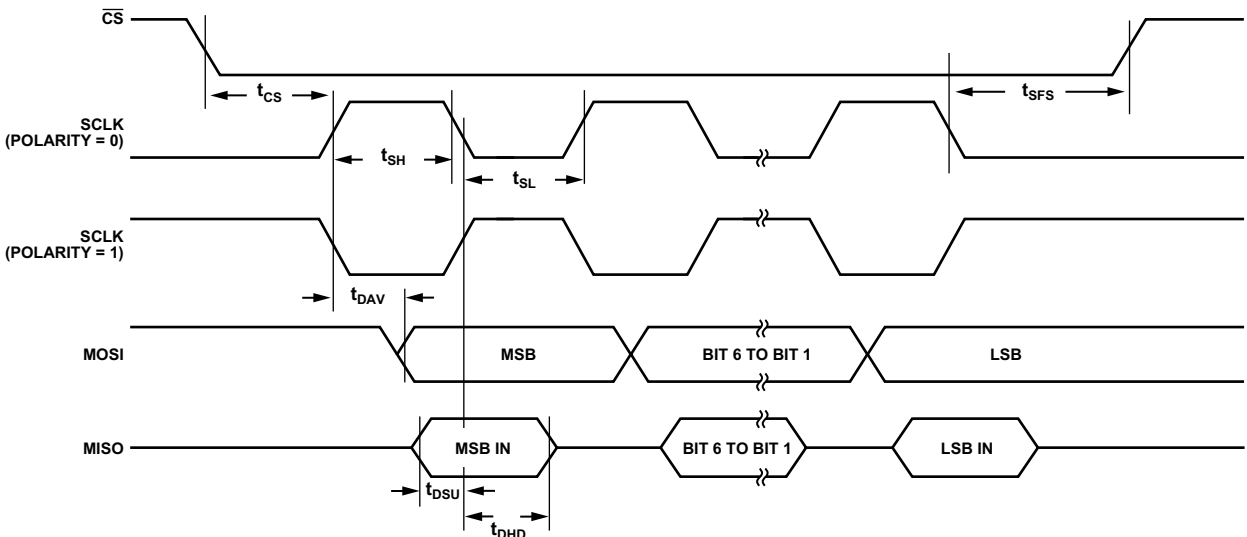

Figure 8. SPI Master Mode Timing (Phase Mode = 1)

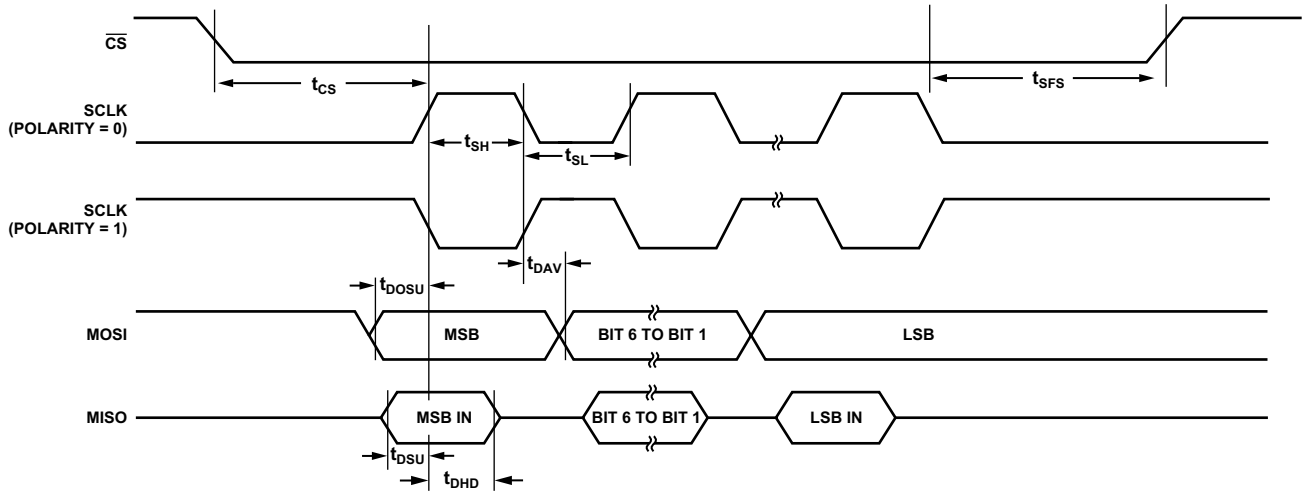

Figure 9. SPI Master Mode Timing (Phase Mode = 0)

Table 19. SPI Slave Mode Timing

Parameter		Min	Max	Unit
TIMING REQUIREMENTS				
t_{CS}	\overline{CS} to SCLK Edge	38.5		ns
t_{SL}	SCLK Low Pulse Width	38.5		ns
t_{SH}	SCLK High Pulse Width	38.5		ns
t_{DSU}	Data Input Setup Time Before SCLK Edge	6		ns
t_{DHD}	Data Input Hold Time After SCLK Edge	8		ns
SWITCHING CHARACTERISTICS				
t_{DAV}	Data Output Valid After SCLK Edge	25		ns
t_{DOCS}	Data Output Valid After \overline{CS} Edge		20	ns
t_{SFS}	\overline{CS} High After SCLK Edge	38.5		ns

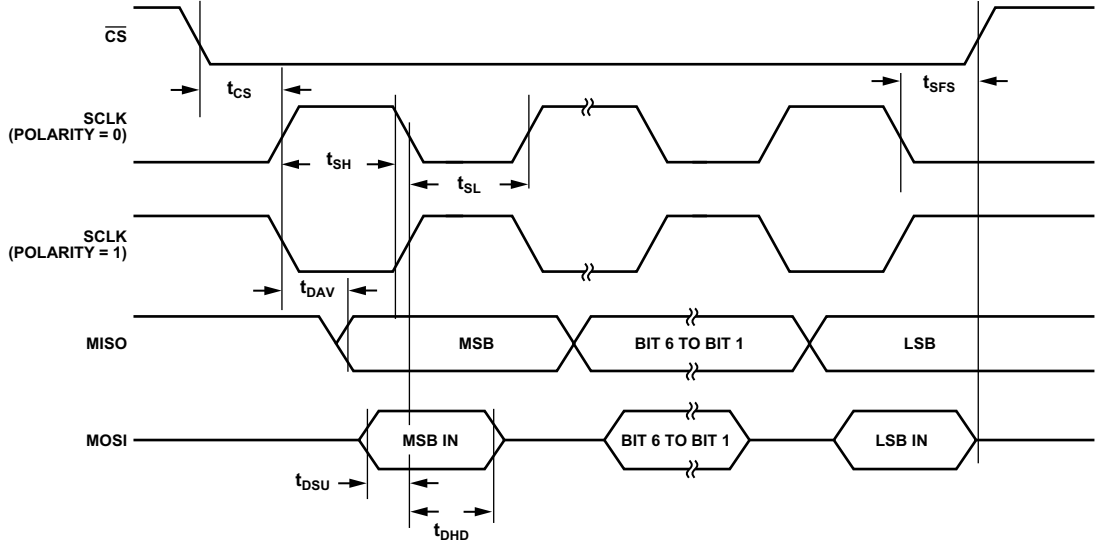

Figure 10. SPI Slave Mode Timing (Phase Mode = 1)

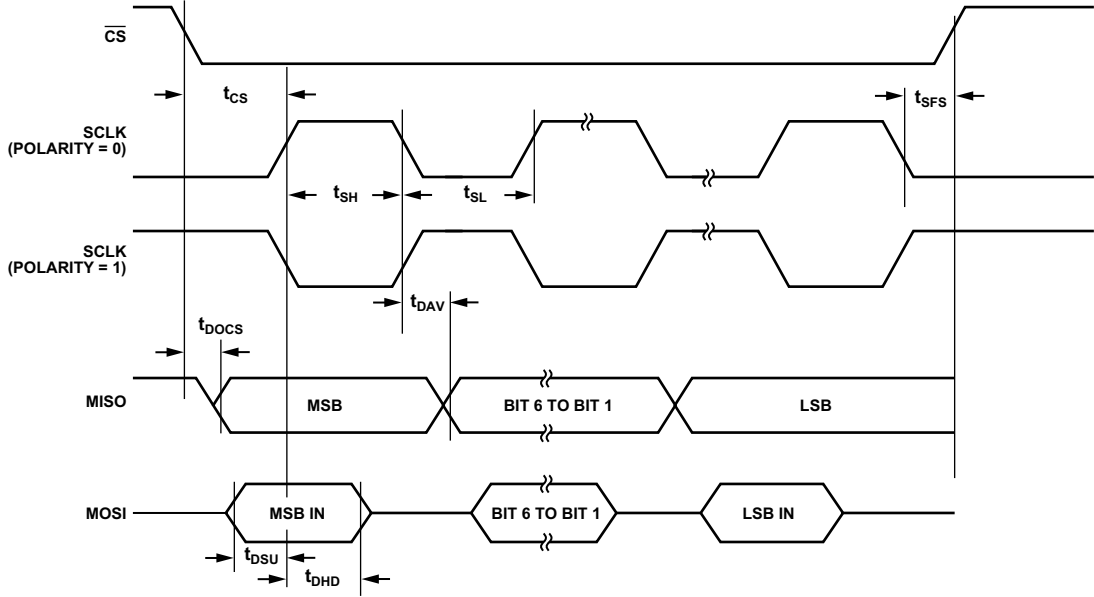

Figure 11. SPI Slave Mode Timing (Phase Mode = 0)

ADuCM3027/ADuCM3029

General-Purpose Port Timing

Table 20 and Figure 12 describe general-purpose port timing.

Table 20. General-Purpose Port Timing

Parameter	Min	Max	Unit
TIMING REQUIREMENTS			
t_{WFI} General-Purpose Port Pin Input Pulse Width	$4 \times t_{PCLK}$		ns

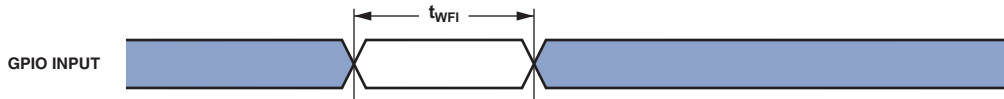

Figure 12. General-Purpose Port Timing

Timer PWM_OUT Cycle Timing

Table 21 and Figure 13 describe timer PWM_OUT cycle timing.

Table 21. Timer PWM_OUT Cycle Timing

Parameter	Min	Max	Unit
SWITCHING CHARACTERISTICS			
t_{PWMO} Timer Pulse Width Output	$4 \times t_{PCLK} - 6$	$256 \times (2^{16} - 1)$	ns

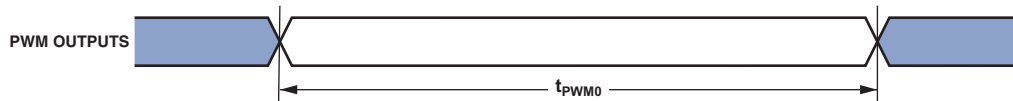

Figure 13. Timer PWM_OUT Cycle Timing

MCU TEST CONDITIONS

The ac signal specifications (timing parameters) that appear in this data sheet include output disable time, output enable time, and others. Timing is measured on signals when they cross the V_{MEAS} level as described in Figure 14. All delays (in ns or μ s) are measured between the point that the first signal reaches V_{MEAS} and the point that the second signal reaches V_{MEAS} . The value of V_{MEAS} is set to $V_{BAT}/2$.

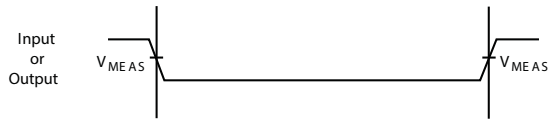
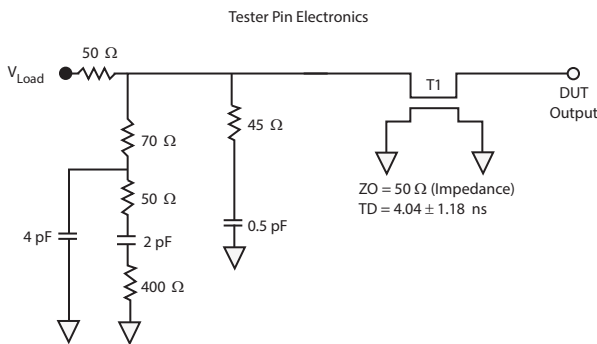

Figure 14. Voltage Reference Levels for AC Measurements (Except Output Enable/Disable)



NOTES:
THE WORST CASE TRANSMISSION LINE DELAY IS SHOWN AND CAN BE USED FOR THE OUTPUT TIMING ANALYSIS TO REFLECT THE TRANSMISSION LINE EFFECT AND MUST BE CONSIDERED. THE TRANSMISSION LINE (TD) IS FOR LOAD ONLY AND DOES NOT AFFECT THE DATA SHEET TIMING SPECIFICATIONS.

ANALOG DEVICES RECOMMENDS USING THE IBIS MODEL TIMING FOR A GIVEN SYSTEM REQUIREMENT. IF NECESSARY, A SYSTEM MAY INCORPORATE EXTERNAL DRIVERS TO COMPENSATE FOR ANY TIMING DIFFERENCES.

Figure 15. Equivalent Device Loading for AC Measurements (Includes All Fixtures)

DRIVER TYPES

Table 22 shows driver types.

Table 22. Driver Types

Driver Type ^{1, 2, 3}	Associated Pins
Type A	P0_00, P0_01, P0_02, P0_03, P0_07, P0_10, P0_11, P0_12, P0_13, P0_15, P1_00, P1_01, P1_02, P1_03, P1_04, P1_05, P1_06, P1_07, P1_08, P1_09, P1_10, P1_15, P2_00, P2_01, P2_04, P2_05, P2_06, P2_07, P2_08, P2_09, P2_10, P2_11, $\overline{\text{SYS_HWRST}}$
Type B	P0_08, P0_09, P0_14, P1_11, P1_12, P1_13, P1_14, P2_02
Type C	P0_04, P0_05
Type D	P0_06

¹ In single drive mode, the maximum source/sink capacity is 2 mA.

² In double drive mode, the maximum source/sink capacity is 4 mA.

³ At maximum drive capacity, only 16 GPIOs are allowed to switch at any given point of time.

ADuCM3027/ADuCM3029

Figure 16 through Figure 21 show the typical current voltage characteristics for the output drivers of the MCU.

The curves represent the current drive capability of the output drivers as a function of output voltage.

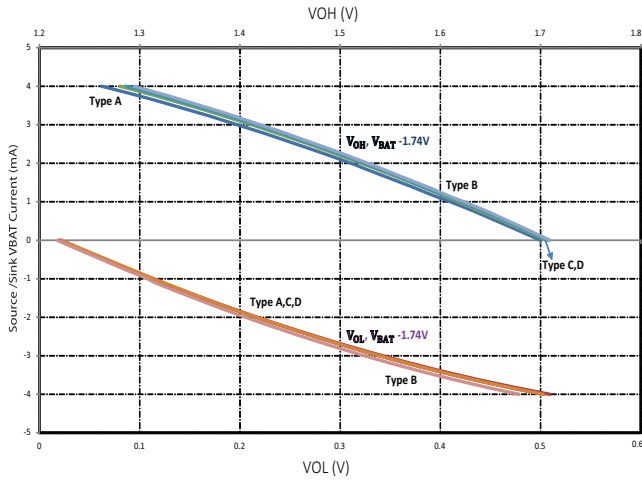

Figure 16. Output Double Drive Strength Characteristics ($V_{BAT} = 1.74\text{ V}$)

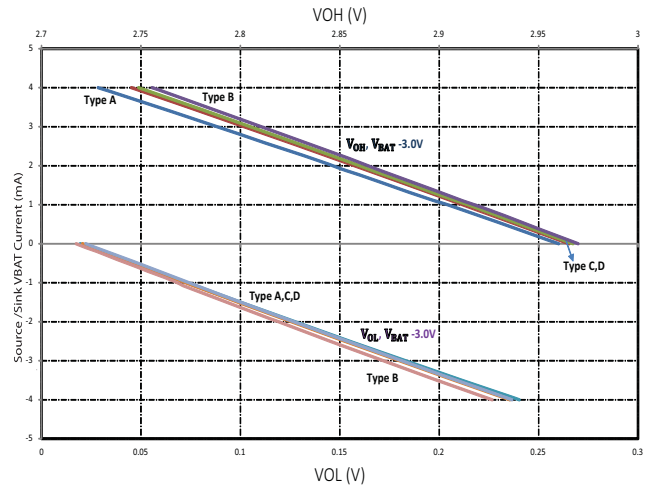

Figure 18. Output Double Drive Strength Characteristics ($V_{BAT} = 3.0\text{ V}$)

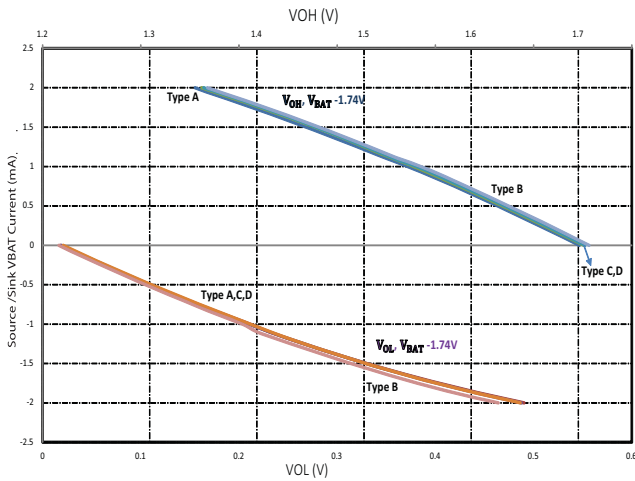

Figure 17. Output Single Drive Strength Characteristics ($V_{BAT} = 1.74\text{ V}$)

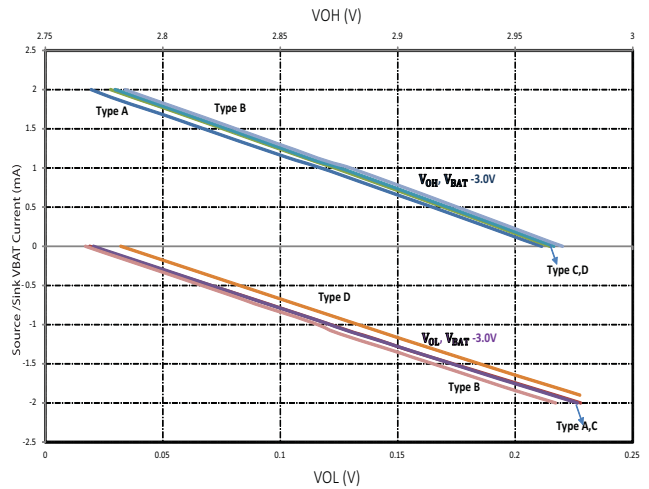

Figure 19. Output Single Drive Strength Characteristics ($V_{BAT} = 3.0\text{ V}$)

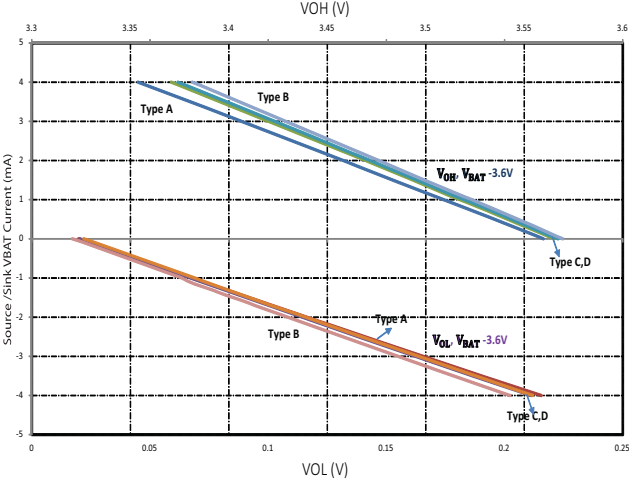

Figure 20. Output Double Drive Strength Characteristics (VBAT = 3.6 V)

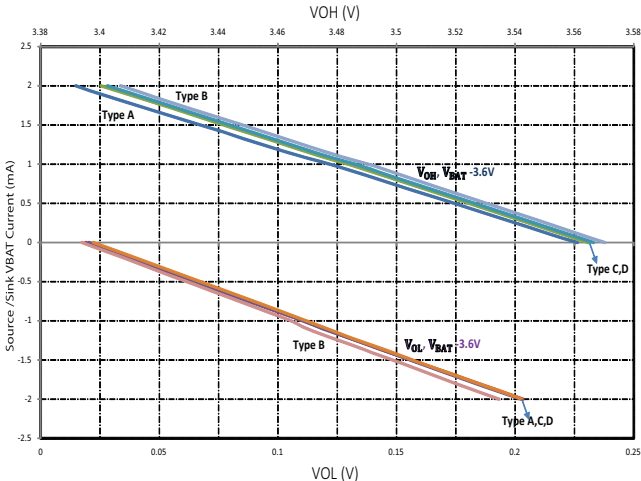

Figure 21. Output Single Drive Strength Characteristics (VBAT = 3.6 V)

ADuCM3027/ADuCM3029

ENVIRONMENTAL CONDITIONS

Table 23. Thermal Characteristics (64-Lead LFCSP)

Parameter	Typ	Unit
θ_{JA}	28.2	$^{\circ}\text{C}/\text{W}$
θ_{JC}	5.4	$^{\circ}\text{C}/\text{W}$

Values of θ_{JA} are provided for package comparison and PCB design considerations. θ_{JA} can be used for a first-order approximation of T_j by the equation:

$$T_j = T_A + (\theta_{JA} \times P_D)$$

where:

T_A is ambient temperature ($^{\circ}\text{C}$).

T_j is junction temperature ($^{\circ}\text{C}$).

P_D is power dissipation (To calculate P_D , see the [Power Supply Current](#) section).

Values of θ_{JC} are provided for package comparison and PCB design considerations when an external heat sink is required.

PIN CONFIGURATION AND FUNCTION DESCRIPTION

Figure 22 shows an overview of signal placement on the 64-Lead LFCSP_WQ.

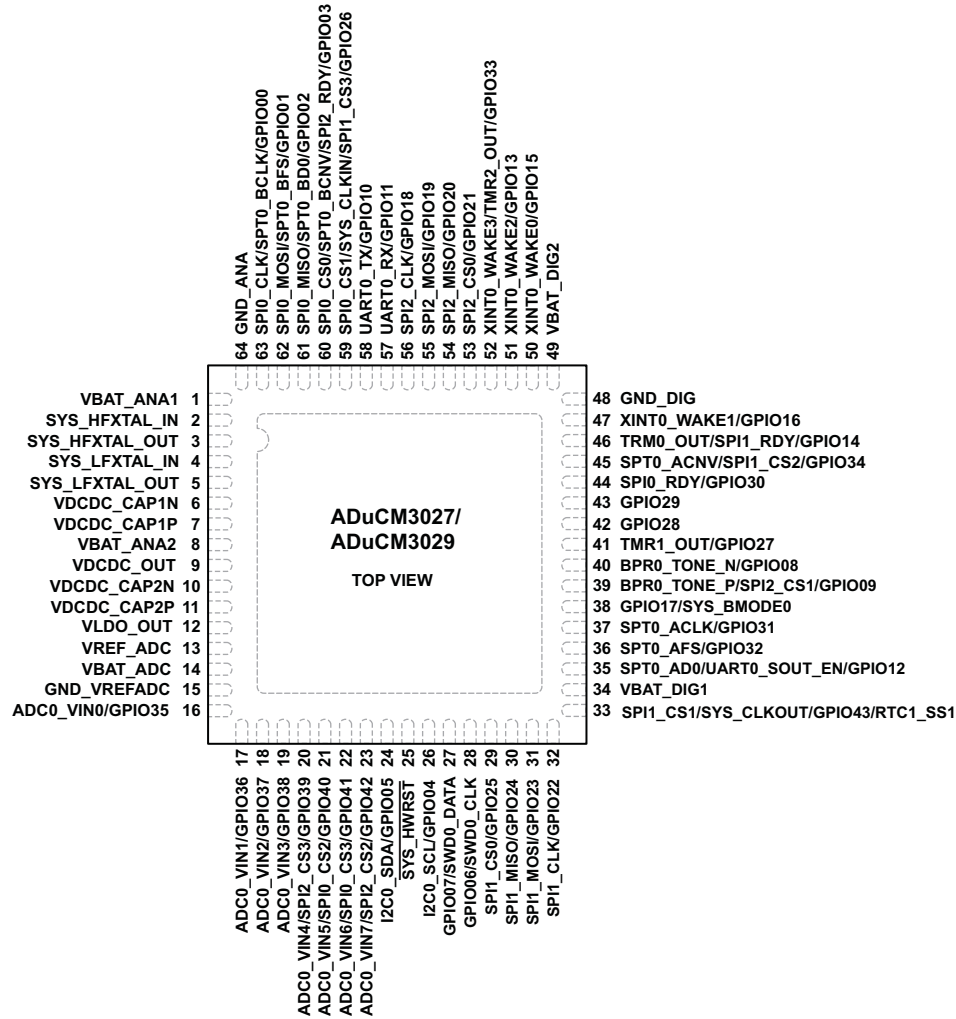

Figure 22. 64-Lead LFCSP Configuration

ADuCM3027/ADuCM3029

Figure 23 shows an overview of signal placement on the 54-Ball WLCSP.

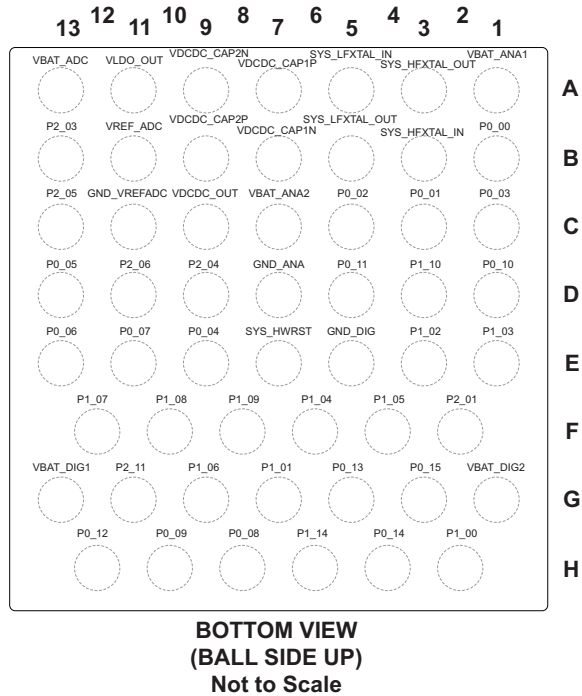

Figure 23. 54-Ball WLCSP Configuration

Table 24 lists the signal descriptions of the ADuCM3027/ADuCM3029 MCUs.

Table 24. Signal Functional Descriptions

GPIO Signal Name	Description
SPI _n _CLK	SPI Clock. n = 0, 1, 2.
SPI _n _MOSI	SPI Master Out Slave In. n = 0, 1, 2.
SPI _n _MISO	SPI Master In Slave Out. n = 0, 1, 2.
SPI _n _RDY	SPI Ready Signal. n = 0, 1, 2.
SPI _n _CS _m	SPI Chip Select Signal. n = 0, 1, 2 and m = 0, 1, 2, 3.
SPT0_ACLK	SPORT A Clock Signal.
SPT0_AFS	SPORT A Frame Sync.
SPT0_AD0	SPORT A Data Pin 0.
SPT0_ACNV	SPORT A Converter Signal for Interface with ADC.
SPT0_BCLK	SPORT B Clock Signal.
SPT0_BFS	SPORT B Frame Sync.
SPT0_BD0	SPORT B Data Pin 0.
SPT0_BCNV	SPORT B Converter Signal for Interface with ADC.
I2C0_SCL	I ² C Clock.
I2C0_SDA	I ² C Data.
SWD0_CLK	Serial Wire Debug Clock.
SWD0_DATA	Serial Wire Debug Data.
BPR0_TONE _N	Beeper Tone Negative Pin.
BPR0_TONE _P	Beeper Tone Positive Pin.
UART0_TX	UART Transmit Pin.
UART0_RX	UART Receive Pin.
UART0_SOUT_EN	UART Serial Data Out Pin.
XINT0_WAKEn	System Wake-Up Pin. Wake Up from Flexi/Hibernate/Shutdown Modes ¹ . n = 0, 1, 2, 3.
TMR _n _OUT	Timer Output Pin. n = 0, 1, 2.
SYS_BMODE0	Boot Mode Pin.
SYS_CLKIN	External Clock In Pin.
SYS_CLKOUT	External Clock Out Pin.
RTC1_SS1	RTC1 SensorStrobe Pin.
ADC0_VIN _n	ADC Voltage Input Pin. n = 0, 1, 2, 3, 4, 5, 6, 7.

¹ For shutdown, XINT0_WAKE3 is not capable of waking the device from shutdown mode.

ADuCM3027/ADuCM3029

Table 25 lists the 64-Lead LFCSP_WQ package by pin number for the ADuCM3027/ADuCM3029 MCUs.

Table 25. Pin Function Descriptions, 64-Lead LFCSP_WQ

Pin No.	GPIO	Signal Name	Description	GPIO Pull
1		VBAT_ANA1	Analog 3 V Supply.	
2		SYS_HFXTAL_IN	26 MHz High Frequency Crystal.	
3		SYS_HFXTAL_OUT	26 MHz High Frequency Crystal.	
4		SYS_LFXTAL_IN	32 kHz Low Frequency Crystal.	
5		SYS_LFXTAL_OUT	32 kHz Low Frequency Crystal.	
6		VDCDC_CAP1N	Buck Fly Capacitor.	
7		VDCDC_CAP1P	Buck Fly Capacitor.	
8		VBAT_ANA2	Analog 3 V Supply.	
9		VDCDC_OUT	Buck Output Capacitor.	
10		VDCDC_CAP2N	Buck Fly Capacitor.	
11		VDCDC_CAP2P	Buck Fly Capacitor.	
12		VLDO_OUT	LDO Output Capacitor.	
13		VREF_ADC	Analog Reference Voltage for ADC.	
14		VBAT_ADC	Analog 3 V Supply for ADC.	
15		GND_VREFADC	Reference Ground for ADC.	
16	P2_03	ADC0_VIN0/GPIO35		PU
17	P2_04	ADC0_VIN1/GPIO36		PU
18	P2_05	ADC0_VIN2/GPIO37		PU
19	P2_06	ADC0_VIN3/GPIO38		PU
20	P2_07	ADC0_VIN4/SPI2_CS3/GPIO39		PU
21	P2_08	ADC0_VIN5/SPI0_CS2/GPIO40		PU
22	P2_09	ADC0_VIN6/SPI0_CS3/GPIO41		PU
23	P2_10	ADC0_VIN7/SPI2_CS2/GPIO42		PU
24	P0_05	I2C0_SDA/GPIO05		PU
25		SYS_HWRST	System Hardware Reset.	
26	P0_04	I2C0_SCL/GPIO04		PU
27	P0_07	GPIO07/SWD0_DATA		PU
28	P0_06	GPIO06/SWD0_CLK		PD
29	P1_09	SPI1_CS0/GPIO25		PU
30	P1_08	SPI1_MISO/GPIO24		PU
31	P1_07	SPI1_MOSI/GPIO23		PU
32	P1_06	SPI1_CLK/GPIO22		PU
33	P2_11	SPI1_CS1/SYS_CLKOUT/GPIO43/RTC1_SS1		PU
34		VBAT_DIG1	Digital 3 V Supply.	
35	P0_12	SPT0_AD0/GPIO12		PU
36	P2_00	SPT0_AFS/GPIO32		PU
37	P1_15	SPT0_ACLK/GPIO31		PU
38	P1_01	GPIO17/SYS_BMODE0		PU
39	P0_09	BPR0_TONE_P/SPI2_CS1/GPIO09		PU
40	P0_08	BPR0_TONE_N/GPIO08		PU
41	P1_11	TMR1_OUT/GPIO27		PU
42	P1_12	GPIO28		PU
43	P1_13	GPIO29		PU
44	P1_14	SPI0_RDY/GPIO30		PU
45	P2_02	SPT0_ACNV/SPI1_CS2/GPIO34		PU

Table 25. Pin Function Descriptions, 64-Lead LFCSP_WQ (Continued)

Pin No.	GPIO	Signal Name	Description	GPIO Pull
46	P0_14	TMR0_OUT/SPI1_RDY/GPIO14		PU
47	P1_00	XINT0_WAKE1/GPIO16		PU
48		GND_DIG	Digital Ground.	
49		VBAT_DIG2	Digital 3 V Supply.	
50	P0_15	XINT0_WAKE0/GPIO15		PU
51	P0_13	XINT0_WAKE2/GPIO13		PU
52	P2_01	XINT0_WAKE3/TMR2_OUT/GPIO33		PU
53	P1_05	SPI2_CS0/GPIO21		PU
54	P1_04	SPI2_MISO/GPIO20		PU
55	P1_03	SPI2_MOSI/GPIO19		PU
56	P1_02	SPI2_CLK/GPIO18		PU
57	P0_11	UART0_RX/GPIO11		PU
58	P0_10	UART0_TX/GPIO10		PU
59	P1_10	SPI0_CS1/SYS_CLKIN/SPI1_CS3/GPIO26		PU
60	P0_03	SPI0_CS0/SPT0_BCNV/SPI2_RDY/GPIO03		PU
61	P0_02	SPI0_MISO/SPT0_BD0/GPIO02		PU
62	P0_01	SPI0_MOSI/SPT0_BFS/GPIO01		PU
63	P0_00	SPI0_CLK/SPT0_BCLK/GPIO00		PU
64		GND_ANA	Analog Ground.	
Exposed Pad		GND	Ground.	

ADuCM3027/ADuCM3029

Table 26 lists the 54-Ball WLCSP package by ball number for the ADuCM3027/ADuCM3029 MCUs.

Table 26. Pin Function Descriptions, 54-Ball WLCSP

Ball No.	GPIO	Pin Label	Description	GPIO Pull
A01		VBAT_ANA1	Analog 3 V Supply.	
A03		SYS_HFXTAL_OUT	26 MHz High Frequency Crystal.	
A05		SYS_LFXTAL_IN	32 kHz Low Frequency Crystal.	
A07		VDCDC_CAP1P	Buck Fly Capacitor.	
A09		VDCDC_CAP2N	Buck Fly Capacitor.	
A11		VLDO_OUT	LDO Output Capacitor	
A13		VBAT_ADC	Analog 3 V Supply for ADC.	
B01	P0_00	SPI0_CLK/SPT0_BCLK/GPIO00		PU
B03		SYS_HFXTAL_IN	26 MHz High Frequency Crystal.	
B05		SYS_LFXTAL_OUT	32 kHz Low Frequency Crystal.	
B07		VDCDC_CAP1N	Buck Fly Capacitor.	
B09		VDCDC_CAP2P	Buck Fly Capacitor.	
B11		VREF_ADC	Analog Reference Voltage for ADC.	
B13	P2_03	ADC0_VIN0/GPIO35		PU
C01	P0_03	SPI0_CS0/SPT0_BCNV/SPI2_RDY/GPIO03		PU
C03	P0_01	SPI0_MOSI/SPT0_BFS/GPIO01		PU
C05	P0_02	SPI0_MISO/SPT0_BD0/GPIO02		PU
C07		VBAT_ANA2	Analog 3 V Supply.	
C09		VDCDC_OUT	Buck Output Capacitor.	
C11		GND_VREFADC	Reference Ground for ADC.	
C13	P2_05	ADC0_VIN2/GPIO37		PU
D01	P0_10	UART0_TX/GPIO10		PU
D03	P1_10	SPI0_CS1/SYS_CLKIN/SPI1_CS3/GPIO26		PU
D05	P0_11	UART0_RX/GPIO11		PU
D07		GND_ANA	Analog Ground.	
D09	P2_04	ADC0_VIN1/GPIO36		PU
D11	P2_06	ADC0_VIN3/GPIO38		PU
D13	P0_05	I2C0_SDA/GPIO05		PU
E01	P1_03	SPI2_MOSI/GPIO19		PU
E03	P1_02	SPI2_CLK/GPIO18		PU
E05		GND_DIG	Digital Ground.	
E07		SYS_HWRST	System Hardware Reset.	
E09	P0_04	I2C0_SCL/GPIO04		PU
E11	P0_07	GPIO07/SWD0_DATA		PU
E13	P0_06	GPIO06/SWD0_CLK		PD
F02	P2_01	XINT0_WAKE3/TMR2_OUT/GPIO33		PU
F04	P1_05	SPI2_CS0/GPIO21		PU
F06	P1_04	SPI2_MISO/GPIO20		PU
F08	P1_09	SPI1_CS0/GPIO25		PU
F10	P1_08	SPI1_MISO/GPIO24		PU
F12	P1_07	SPI1_MOSI/GPIO23		PU
G01		VBAT_DIG2	Digital 3 V Supply.	
G03	P0_15	XINT0_WAKE0/GPIO15		PU

Table 26. Pin Function Descriptions, 54-Ball WLCSP (Continued)

Ball No.	GPIO	Pin Label	Description	GPIO Pull
G05	P0_13	XINT0_WAKE2/GPIO13	Digital 3 V Supply.	PU
G07	P1_01	GPIO17/SYS_BMODE0		PU
G09	P1_06	SPI1_CLK/GPIO22		PU
G11	P2_11	SPI1_CS1/SYS_CLKOUT/GPIO43/RTC1_SS1		PU
G13		VBAT_DIG1		
H02	P1_00	XINT0_WAKE1/GPIO16		PU
H04	P0_14	TMR0_OUT/SPI1_RDY/GPIO14		PU
H06	P1_14	SPI0_RDY/GPIO30		PU
H08	P0_08	BPR0_TONE_N/GPIO08		PU
H10	P0_09	BPR0_TONE_P/SPI2_CS1/GPIO09		PU
H12	P0_12	SPT0_AD0/GPIO12/UART0_SOUT_EN		PU

OUTLINE DIMENSIONS

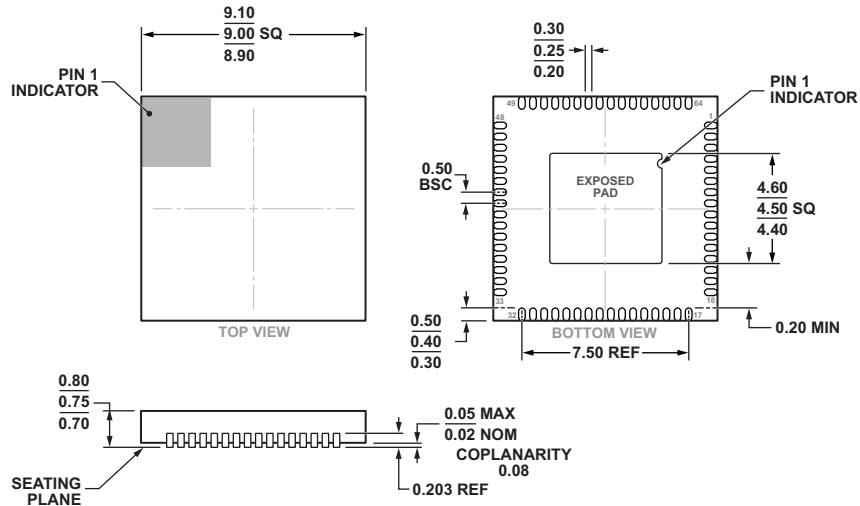

Figure 24. 64-Lead Frame Chip Scale Package [LFCSP]
9 mm x 9 mm Body and 0.75 mm Package Height
(CP-64-16)

Dimensions shown in mm

Note: Exposed pad must be grounded

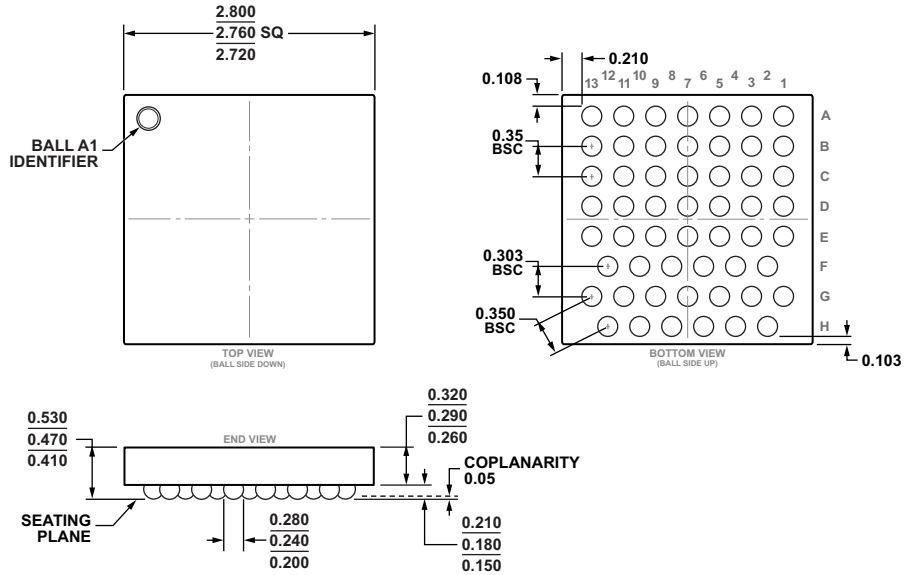

Figure 25. 54-Ball Wafer Level Chip Scale Package [WL CSP]
(CB-54-1)

Dimensions shown in mm

ADuCM3027/ADuCM3029

ORDERING GUIDE

Model ¹	Description	Temperature ^{2, 3}	Package Description	Package Option
ADUCM3027BCBZ-RL	ULP ARM Cortex-M3 with 128 KB Embedded Flash	-40°C to +85°C	54-Ball WLCSP, 13" Reel	CB-54-1
ADUCM3027BCBZ-R7	ULP ARM Cortex-M3 with 128 KB Embedded Flash	-40°C to +85°C	54-Ball WLCSP, 7" Reel	CB-54-1
ADUCM3027BCPZ	ULP ARM Cortex-M3 with 128 KB Embedded Flash	-40°C to +85°C	64-Lead LFCSP	CP-64-16
ADUCM3027BCPZ-RL	ULP ARM Cortex-M3 with 128 KB Embedded Flash	-40°C to +85°C	64-Lead LFCSP, 13" Reel	CP-64-16
ADUCM3027BCPZ-R7	ULP ARM Cortex-M3 with 128 KB Embedded Flash	-40°C to +85°C	64-Lead LFCSP, 7" Reel	CP-64-16
ADUCM3029BCBZ-RL	ULP ARM Cortex-M3 with 256 KB Embedded Flash	-40°C to +85°C	54-Ball WLCSP, 13" Reel	CB-54-1
ADUCM3029BCBZ-R7	ULP ARM Cortex-M3 with 256 KB Embedded Flash	-40°C to +85°C	54-Ball WLCSP, 7" Reel	CB-54-1
ADUCM3029BCPZ	ULP ARM Cortex-M3 with 256 KB Embedded Flash	-40°C to +85°C	64-Lead LFCSP	CP-64-16
ADUCM3029BCPZ-RL	ULP ARM Cortex-M3 with 256 KB Embedded Flash	-40°C to +85°C	64-Lead LFCSP, 13" Reel	CP-64-16
ADUCM3029BCPZ-R7	ULP ARM Cortex-M3 with 256 KB Embedded Flash	-40°C to +85°C	64-Lead LFCSP, 7" Reel	CP-64-16
ADZS-UCM3029EZLITE	ADuCM3029 Evaluation Kit	-40°C to +85°C	64-Lead LFCSP	CP-64-16

¹ Z = RoHS Compliant Part.

² Referenced temperature is ambient temperature. The ambient temperature is not a specification. See the [Absolute Maximum Ratings](#) section for T_j (junction temperature) specification which is the only temperature specification.

³ These are preproduction devices. See ENG-Grade agreement for details.

I²C refers to a communications protocol originally developed by Philips Semiconductors (now NXP Semiconductors).

X-ON Electronics

Largest Supplier of Electrical and Electronic Components

Click to view similar products for [ARM Microcontrollers - MCU category](#):

Click to view products by [Analog Devices manufacturer](#):

Other Similar products are found below :

[MB9BF566NPMC-G-JNE2](#) [MK11DN512AVLK5](#) [MK22FX512AVLK12](#) [MK60DN256VMC10](#) [MK60DX256ZVMD10](#) [MKE02Z32VLC4R](#)
[R7FS3A77C2A01CLK#AC1](#) [SPC560B64L7C6E0X](#) [STM32F205ZGT6J](#) [STM32F412RGY6TR](#) [STM32F439ZGY6TR](#) [STM32F469IIH6](#)
[STM32F722VCT6](#) [STM32L053C6T6](#) [CG8360AM](#) [CP8363AT](#) [CP8570AT](#) [R7FS7G27H2A01CLK#AC0](#) [CY8C4245LTI-DM405](#)
[CY8C4245PVS-482](#) [MB9BF106NAPMC-G-JNE1](#) [MB9BF122LPMC1-G-JNE2](#) [MB9BF122LPMC-G-JNE2](#) [MB9BF128SAPMC-GE2](#)
[MB9BF218TBGL-GE1](#) [MB9BF529TBGL-GE1](#) [XMC4500-E144F1024 AC](#) [EFM32JG1B200F128GM48-C0](#) [STM32F205RGT6W](#) [CP8347AT](#)
[XMC4402-F64K256 AB](#) [MK20DX256VLK10R](#) [STM32L151UCY6TR](#) [STM32L063C8T6](#) [STM32F756ZGY6TR](#) [STM32F446VCT6](#)
[STM32F417VGT6TR](#) [STM32F358CCT6](#) [STM32F302RBT7](#) [MKE06Z64VLD4](#) [MKE04Z128VLD4](#) [MKE02Z16VLC2R](#)
[MK22FN1M0AVLK12R](#) [MK20DX256VLQ10R](#) [MAX32630IWG+T](#) [MAX32630ICQ+](#) [SIM3L167-C-GQR](#) [STM32L053R6H6](#)
[STM32L052K8U6](#) [STM32L052K8T7](#)