

Single 8/Differential 4-Channel CMOS Analog Multiplexers with Active Overvoltage Protection

HI-548/883, HI-549/883

The HI-548/883 and HI-549/883 are analog multiplexers with active overvoltage protection and guaranteed r_{ON} matching. Analog input levels may greatly exceed either power supply without damaging the device or disturbing the signal path of other channels. Active protection circuitry assures that signal fidelity is maintained even under fault conditions that would destroy other multiplexers.

Analog inputs can withstand constant $70V_{P-P}$ levels with $\pm 15V$ supplies. Digital inputs will also sustain continuous faults up to 4V greater than either supply. In addition, signal sources are protected from short circuiting should multiplexer supply loss occur. Each input presents $1k\Omega$ of resistance under this condition. These features make the HI-548/883 and HI-549/883 ideal for use in systems where the analog inputs originate from external equipment or separately powered circuitry. Both devices are fabricated with 44V Dielectrically Isolated CMOS technology. The HI-548/883 is an 8-channel device, and the HI-549/883 is a 4-channel differential version. If input overvoltage protection is not needed, the HI-508/883 and HI-509/883 multiplexers are recommended. For further information see Application Note [AN520](#).

Features

- This Circuit is Processed in Accordance to MIL-STD-883 and is Fully Conformant Under the Provisions of Paragraph 1.2.1.
- No Channel Interaction During Overvoltage
- Guaranteed r_{ON} Matching
- 44V Maximum Power Supply
- Break-Before-Make Switching
- Analog Signal Range $\pm 15V$
- Access Time (Max) $1.0\mu s$
- Power Dissipation (Max) $45mW$

Applications

- Data Acquisition Systems
- Control Systems
- Telemetry

Ordering Information

PART #	PART MARKING	TEMP. RANGE (°C)	PACKAGE	PKG. DWG. #
HI1-0548/883	HI1-548/883	-55 to 125	16 Ld CerDIP	F16.3
HI4-0548/883	HI4-0548 /883	-55 to 125	20 Ld CLCC	J20.A
HI1-0549/883	HI1-549/883	-55 to 125	16 Ld CerDIP	F16.3

Pin Configurations

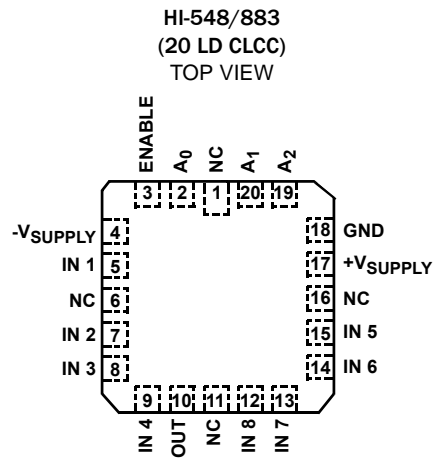
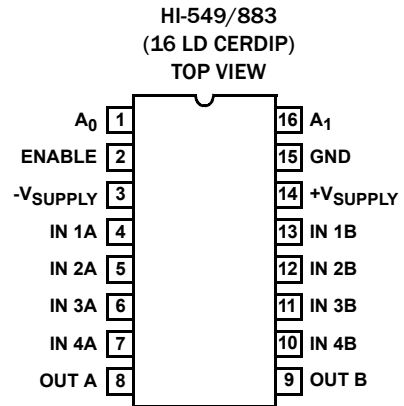
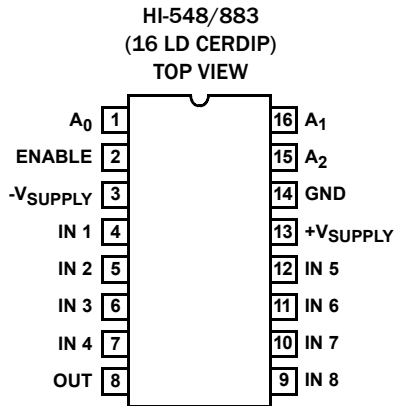

Functional Diagrams

HI-548/883

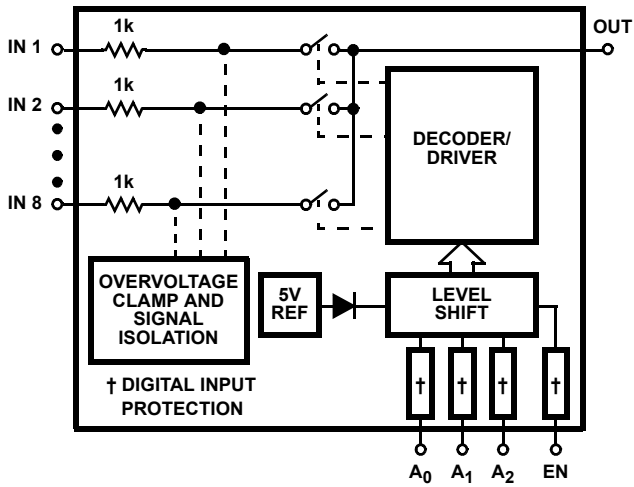

TRUTH TABLE HI-548/883

A ₂	A ₁	A ₀	EN	"ON" CHANNEL
X	X	X	L	None
L	L	L	H	1
L	L	H	H	2
L	H	L	H	3
L	H	H	H	4
H	L	L	H	5
H	L	H	H	6
H	H	L	H	7
H	H	H	H	8

HI-549/883

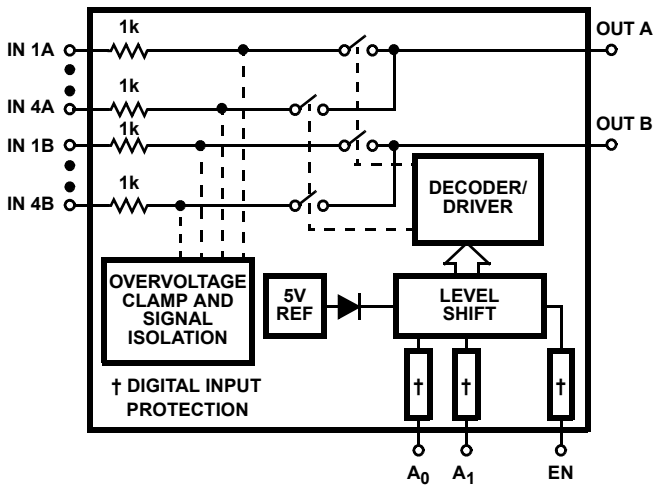

TRUTH TABLE HI-549/883

A ₁	A ₀	EN	"ON" CHANNEL PAIR
X	X	L	None
L	L	H	1
L	H	H	2
H	L	H	3
H	H	H	4

HI-548/883, HI-549/883

Absolute Maximum Ratings

Voltage Between Supply Pins	44V
+V _{SUPPLY} to Ground	22V
-V _{SUPPLY} to Ground	25V
Analog Input Voltage, +V _S	+V _{SUPPLY} +20V
-V _S	-V _{SUPPLY} -20V
Digital Input Voltage, +V _{EN} , +V _A	+V _{SUPPLY} +4V
-V _{EN} , -V _A	-V _{SUPPLY} +4V
	or 20mA, whichever occurs first
Continuous Current, S or D	20mA
Peak Current, S or D (Pulsed at 1ms, 10% Duty Cycle Max)	40mA
ESD Classification	≤2000V

Thermal Information

Thermal Resistance	θ_{JA} (°C/W)	θ_{JC} (°C/W)
CerDIP Package	80	26
CLCC Package	76	19
Power Dissipation (AT +75 °C)		
CerDIP Package	1.25W	
CLCC Package	1.32W	
Power Dissipation Derating Factor (Above +75 °C)		
CerDIP Package125mW/°C	
CLCC Package132mW/°C	
Junction Temperature	+175 °C	
Storage Temperature Range	-65 °C to +150 °C	
Lead Temperature (Soldering 10s)	+275 °C	

Recommended Operating Conditions

Operating Temperature Range	-55 °C to +125 °C
Operating Supply Voltage ($\pm V_{SUPPLY}$)	$\pm 15V$
Analog Input Voltage (V _S)	$\pm V_{SUPPLY}$
Logic Low Level (V _{AL})	0V to 0.8V
Logic High Level (V _{AH})	+4V to +V _{SUPPLY}
Max RMS Current, S or D	8mA

CAUTION: Do not operate at or near the maximum ratings listed for extended periods of time. Exposure to such conditions may adversely impact product reliability and result in failures not covered by warranty.

TABLE 1. D.C. ELECTRICAL PERFORMANCE SPECIFICATIONS

Device Tested at: +V_{SUPPLY} = +15V, -V_{SUPPLY} = -15V, V_{EN} = 4.0V, unless otherwise specified.

D.C. PARAMETERS	SYMBOL	CONDITIONS	GROUP A SUBGROUPS	TEMPERATURE (°C)	MIN	MAX	UNITS
Input Leakage Current	I _{IH}	Measure inputs sequentially, connect all unused inputs to GND	1, 2, 3	+25, +125, -55	-1.0	1.0	μA
	I _{IL}		1, 2, 3	+25, +125, -55	-1.0	1.0	μA
Source "OFF" Leakage Current	+I _{S(OFF)}	V _S = +10V, V _D = -10V, V _{EN} = 0.8V, All unused inputs = -10V	1	+25	-10	10	nA
			2, 3	+125, -55	-50	50	nA
	-I _{S(OFF)}	V _S = -10V, V _D = +10V, V _{EN} = 0.8V, All unused inputs = +10V	1	+25	-10	10	nA
			2, 3	+125, -55	-50	50	nA
Drain "OFF" Leakage Current	+I _{D(OFF)}	V _D = +10V, V _{EN} = 0.8V, All unused inputs = -10V	1	+25	-10	10	nA
			2, 3	+125, -55	-200	200	nA
			2, 3	+125, -55	-100	100	nA
	-I _{D(OFF)}	V _D = -10V, V _{EN} = 0.8V, All unused inputs = +10V	1	+25	-10	10	nA
			2, 3	+25 to +125	-200	200	nA
			2, 3	+125, -55	-100	100	nA
Channel "ON" Leakage Current	+I _{D(ON)}	V _S = V _D = +10V, All unused inputs = -10V	1	+25	-10	10	nA
			2, 3	+125, -55	-200	200	nA
			2, 3	+125, -55	-100	100	nA
	-I _{D(ON)}	V _S = V _D = -10V, All unused inputs = +10V	1	+25	-10	10	nA
			2, 3	+125, -55	-200	200	nA
			2, 3	+125, -55	-100	100	nA

HI-548/883, HI-549/883

TABLE 1. D.C. ELECTRICAL PERFORMANCE SPECIFICATIONS (Continued)

Device Tested at: +V_{SUPPLY} = +15V, -V_{SUPPLY} = -15V, V_{EN} = 4.0V, unless otherwise specified.

D.C. PARAMETERS	SYMBOL	CONDITIONS	GROUP A SUBGROUPS	TEMPERATURE (°C)	MIN	MAX	UNITS
Overvoltage Protected, Leakage Current Into the Drain Terminal of an "OFF" Switch	I _{D(OFF)} Overvoltage	V _S = 33V, V _D = 0V, V _{EN} = 0.8V V _S applied at ≤25% duty cycle	1, 2, 3	+25, +125, -55	-2.0	2.0	μA
		V _S = -33V, V _D = 0V, V _{EN} = 0.8V V _S applied at ≤25% duty cycle	1, 2, 3	+25, +125, -55	-2.0	2.0	μA
Positive Supply Current	+I	V _A = 0V, V _{EN} = 4.0V	1, 2, 3	+25, +125, -55	-	2.0	mA
Negative Supply Current	-I	V _A = 0V, V _{EN} = 4.0V	1, 2, 3	+25, +125, -55	-1.0	-	mA
Standby Positive Supply Current	+I _{SBY}	V _A = 0V, V _{EN} = 0V	1, 2, 3	+25, +125, -55		2.0	mA
Standby Negative Supply Current	-I _{SBY}	V _A = 0V, V _{EN} = 0V	1, 2, 3	+25, +125, -55	-1.0	-	mA
Switch "ON" Resistance	+r _{DS1}	V _S = 10V, I _D = 100μA	1	+25	-	1500	Ω
			2, 3	+125, -55	-	1800	Ω
	-r _{DS1}	V _S = -10V, I _D = -100μA	1	+25	-	1500	Ω
			2, 3	+125, -55	-	1800	Ω
Logic Level Voltage	V _{AL}	Notes 1, 2	1, 2, 3	+25, +125, -55	-	0.8	V
	V _{AH}	Notes 1, 2	1, 2, 3	+25, +125, -55	4.0	-	V
Difference in Switch "ON" Resistance Between Channels	+Δr _{DS1}	$\frac{(+r_{DS1} \text{ MAX}) - (+r_{DS1} \text{ MIN}) \times 100}{+r_{DS1} \text{ AVE}}$	1	+25	-	7	%
	-Δr _{DS1}	$\frac{(-r_{DS1} \text{ MAX}) - (-r_{DS1} \text{ MIN}) \times 100}{-r_{DS1} \text{ AVE}}$	1	+25	-	7	%

TABLE 2. A.C. ELECTRICAL PERFORMANCE SPECIFICATIONS

Device Tested at: +V_{SUPPLY} = +15V, -V_{SUPPLY} = -15V, V_{EN} = 4.0V, unless otherwise specified.

PARAMETERS	SYMBOL	CONDITIONS	GROUP A SUBGROUPS	TEMPERATURE (°C)	MIN	MAX	UNITS
Break-Before-Make Time Delay	t _D	R _L = 1kΩ, C _L = 12.5pF	9	+25	25		ns
Propagation Delay Times: Address Inputs to I/O Channel Times	t _A	R _L = 10MΩ, C _L = 14pF	9	+25		500	ns
			10, 11	+125, -55		1000	ns
Enable to I/O	t _{ON(EN)}	R _L = 1kΩ, C _L = 12.5pF	9	+25		500	ns
			10, 11	+125, -55		1000	ns
	t _{OFF(EN)}	R _L = 1kΩ, C _L = 12.5pF	9	+25		500	ns
			10, 11	+125, -55		1000	ns

HI-548/883, HI-549/883

TABLE 3. ELECTRICAL PERFORMANCE SPECIFICATIONS

Device Tested at: $+V_{SUPPLY} = +15V$, $-V_{SUPPLY} = -15V$, $V_{EN} = 4.0V$, unless otherwise specified.

PARAMETERS	SYMBOL	CONDITIONS	NOTE	TEMPERATURE (°C)	MIN	MAX	UNITS
Capacitance Address Input	C_A	$V+ = V- = 0V$, $f = 1MHz$	3	+25		10	pF
Capacitance Output Switch	C_{OS}	$V+ = V- = 0V$ HI-548/883	3	+25		45	pF
		$f = 1MHz$ HI-549/883	3	+25		25	pF
Capacitance Input Switch	C_{IS}	$V+ = V- = 0V$, $f = 1MHz$	3	+25		15	pF
Charge Transfer Error	V_{CTE}	$V_S = GND$, $V_{GEN} = 0V$ to $5V$, $f = 200kHz$	3	+25		10	mV
Off Isolation	V_{ISO}	$V_{EN} = 0.8V$, $R_L = 1k\Omega$, $C_L = 15pF$, $V_S = 7V_{RMS}$, $f = 100kHz$	3, 4	+25	-50		dB

NOTES:

1. Used for forcing conditions for all DC Tests, unless otherwise specified.
2. To drive from DTL/TTL circuits, $1k\Omega$ pull-up resistors to $+5.0V$ supply are recommended.
3. The parameters listed in this table are controlled via design or process parameters and are not directly tested. These parameters are characterized upon initial design release and upon design changes which would affect these characteristics.
4. Worst case isolation occurs on channel 8B due to proximity of the output pins.

TABLE 4. ELECTRICAL TEST REQUIREMENTS

MIL-STD-883 TEST REQUIREMENTS	SUBGROUPS (See Tables 1, 2, 3)
Interim Electrical Parameters (Pre Burn-in)	1
Final Electrical Test Parameters	1 (Note 5), 2, 3, 9, 10, 11
Group A Test Requirements	1, 2, 3, 9, 10, 11
Groups C & D Endpoints	1

NOTE:

5. PDA applies to Subgroup 1 only. No other subgroups are included in PDA.

Test Circuits

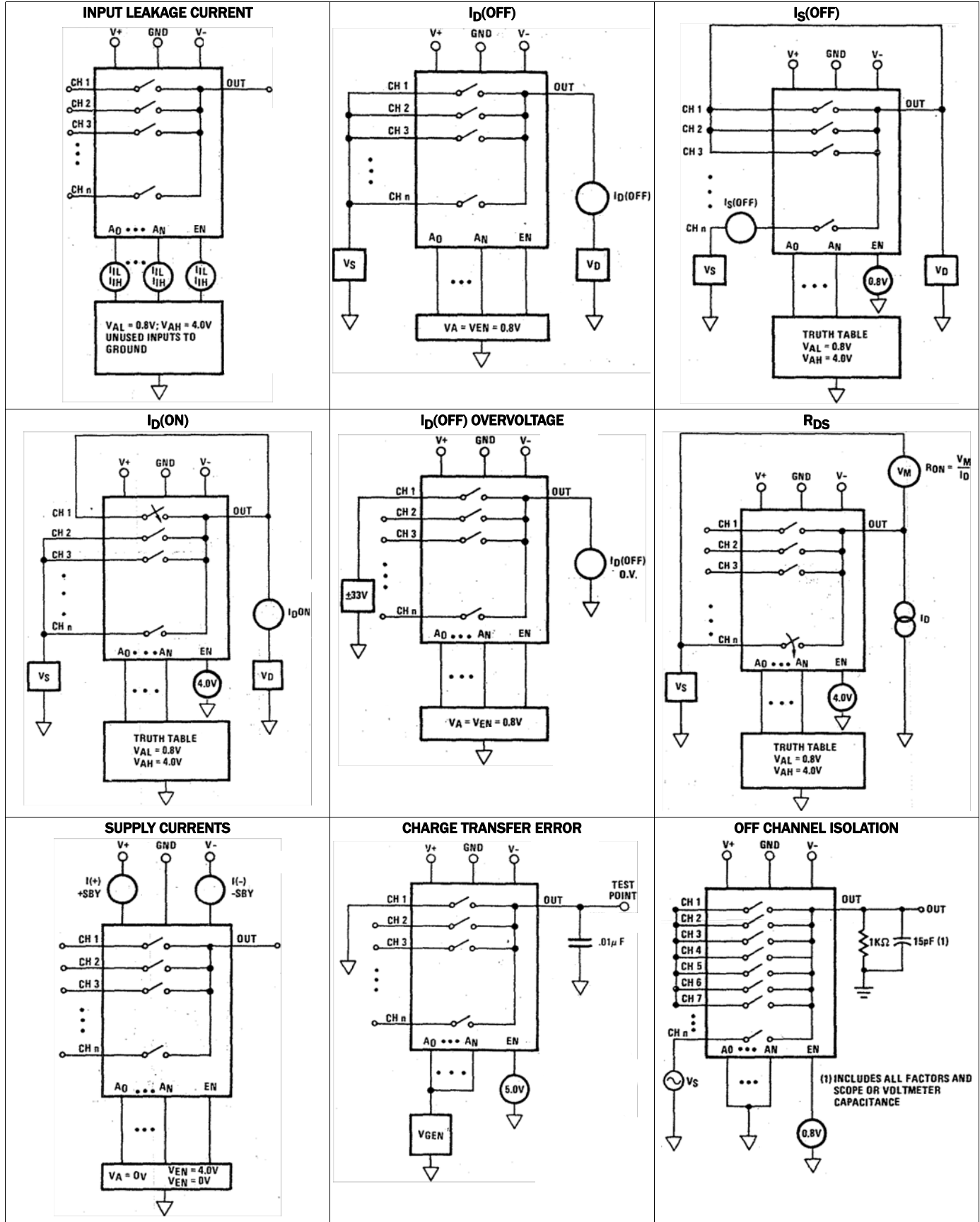

Switching Waveforms

BREAK-BEFORE-MAKE DELAY (t_{OPEN})

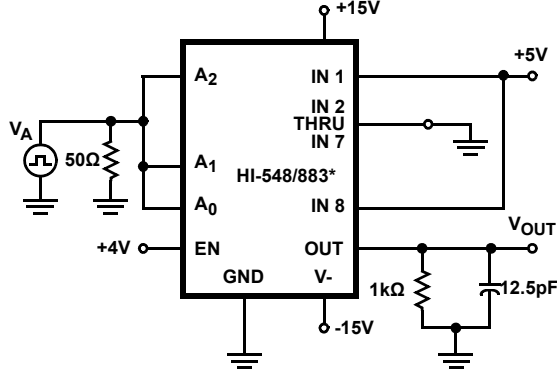
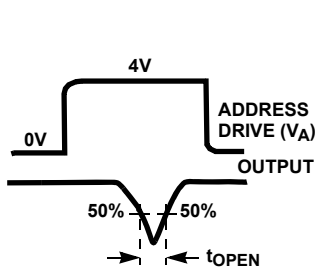

*SIMILAR CONNECTION FOR HI-549/883

BREAK-BEFORE-MAKE DELAY (t_{OPEN})

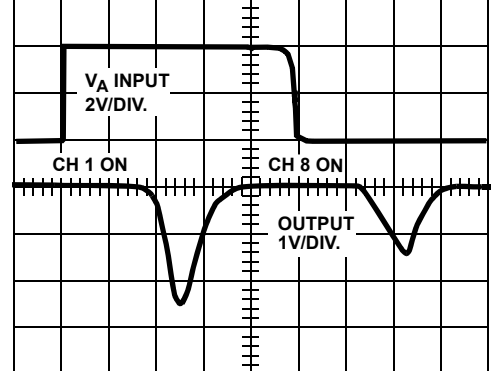

100ns/DIV.

ACCESS TIME vs LOGIC LEVEL (HIGH)

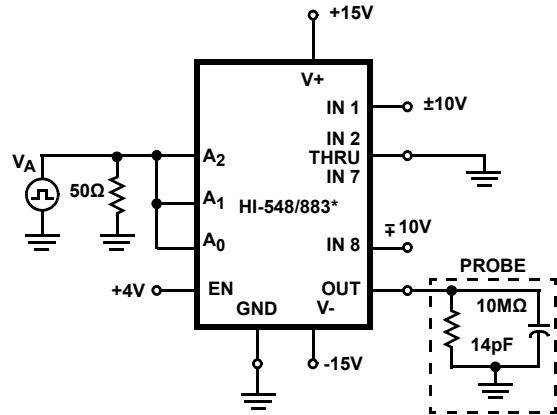
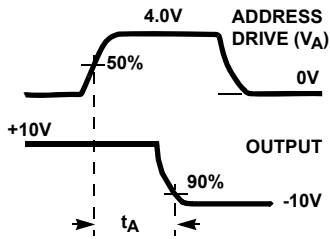

*SIMILAR CONNECTION FOR HI-549/883

ACCESS TIME

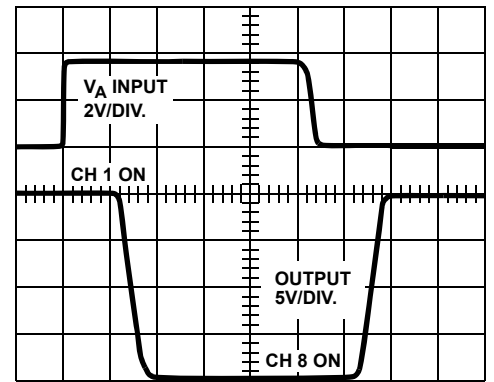

200ns/DIV.

ENABLE DRIVE

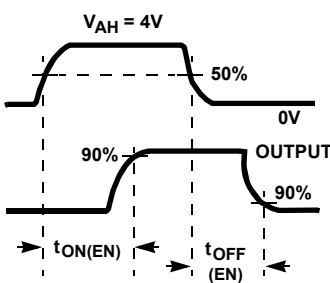

ENABLE DELAY

$t_{ON(EN)}$, $t_{OFF(EN)}$

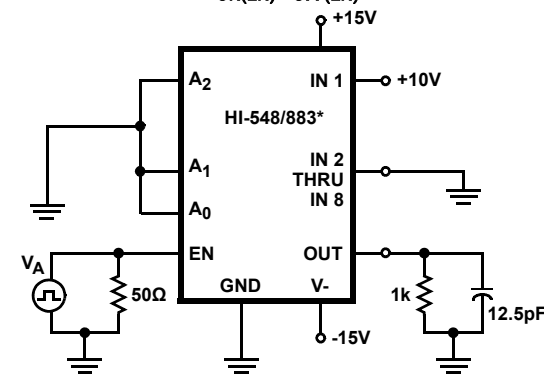

*SIMILAR CONNECTION FOR HI-549/883

ENABLE DELAY

$t_{ON(EN)}$, $t_{OFF(EN)}$

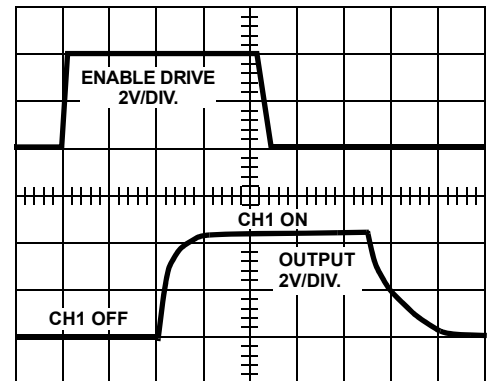

100ns/DIV.

Burn-In Circuits

HI-548/883 CERDIP

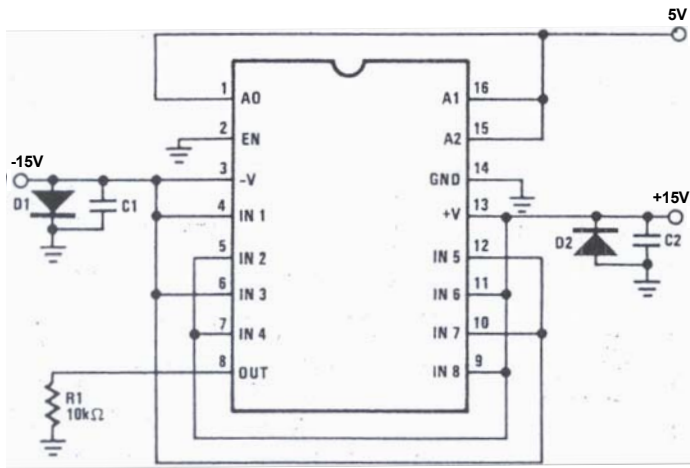

NOTES:

R1 = 10kΩ ± 5% 1/2W or 1/4W (per socket)
 C1, C2 = 0.01μF (per socket) or 0.1μF (per row)
 D1, D2 = 1N4002 (or equivalent) (per board)

HI-548/883 CLCC

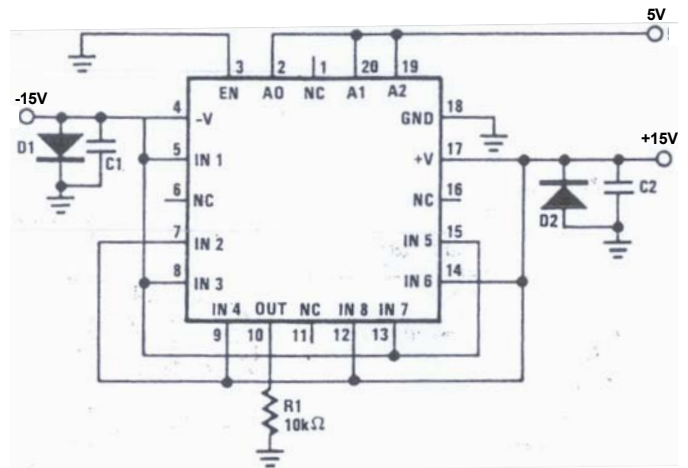

NOTES:

R1 = 10kΩ ± 5% 1/2W or 1/4W (per socket)
 C1, C2 = 0.01μF (per socket) or 0.1μF (per row)
 D1, D2 = 1N4002 (or equivalent) (per board)

HI-549/883 CERDIP

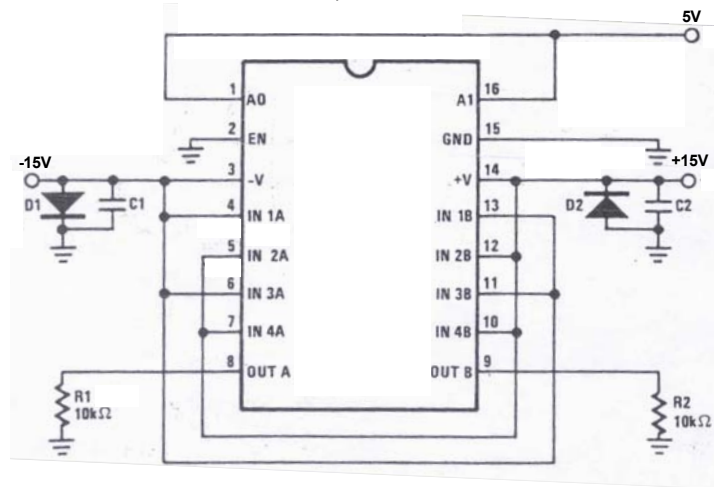

NOTES:

R1, R2 = 10kΩ ± 5% 1/2W or 1/4W (per socket)
 C1, C2 = 0.01μF (per socket) or 0.1μF (per row)
 D1, D2 = 1N4002 (or equivalent) (per board)

Schematic Diagrams

ADDRESS INPUT BUFFER AND LEVEL SHIFTER

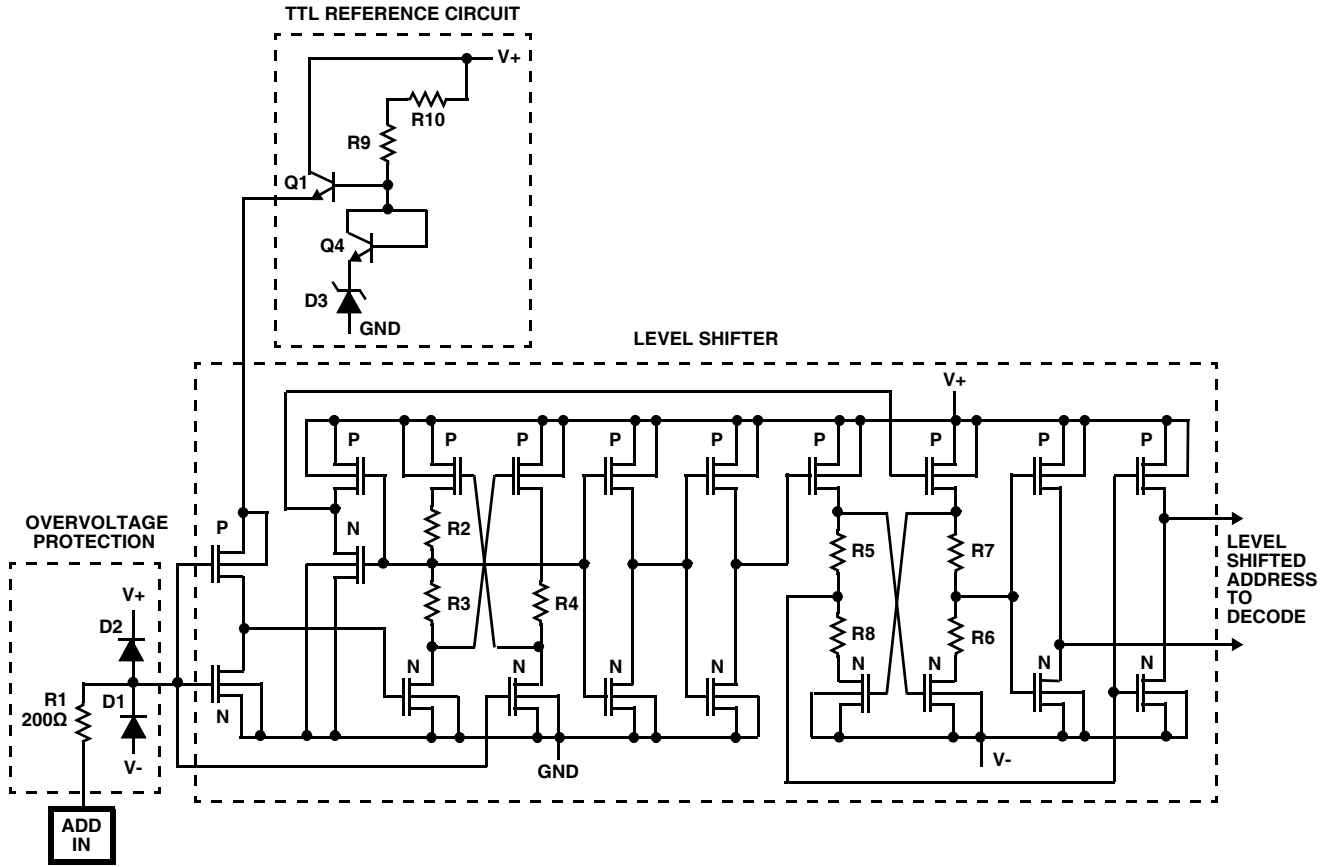

ADDRESS DECODER

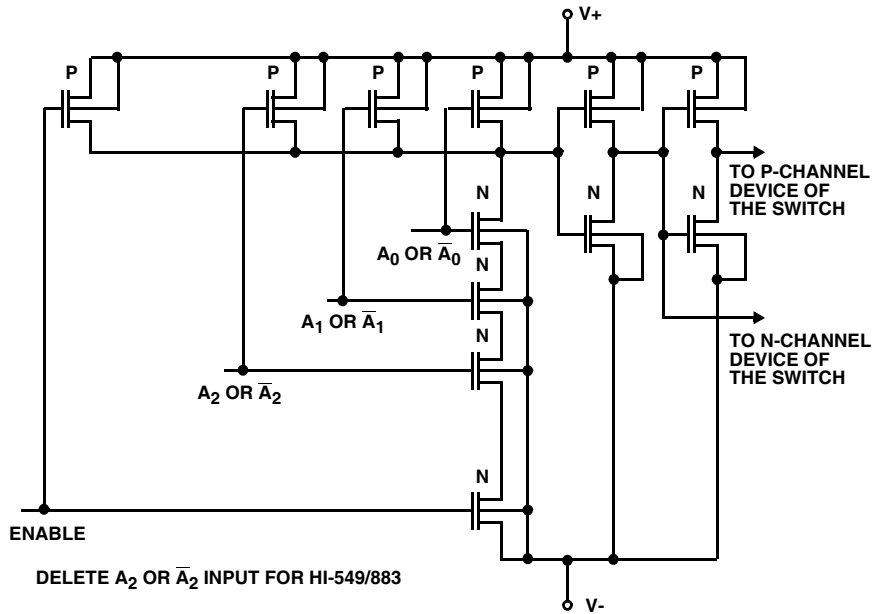

Schematic Diagrams (Continued)

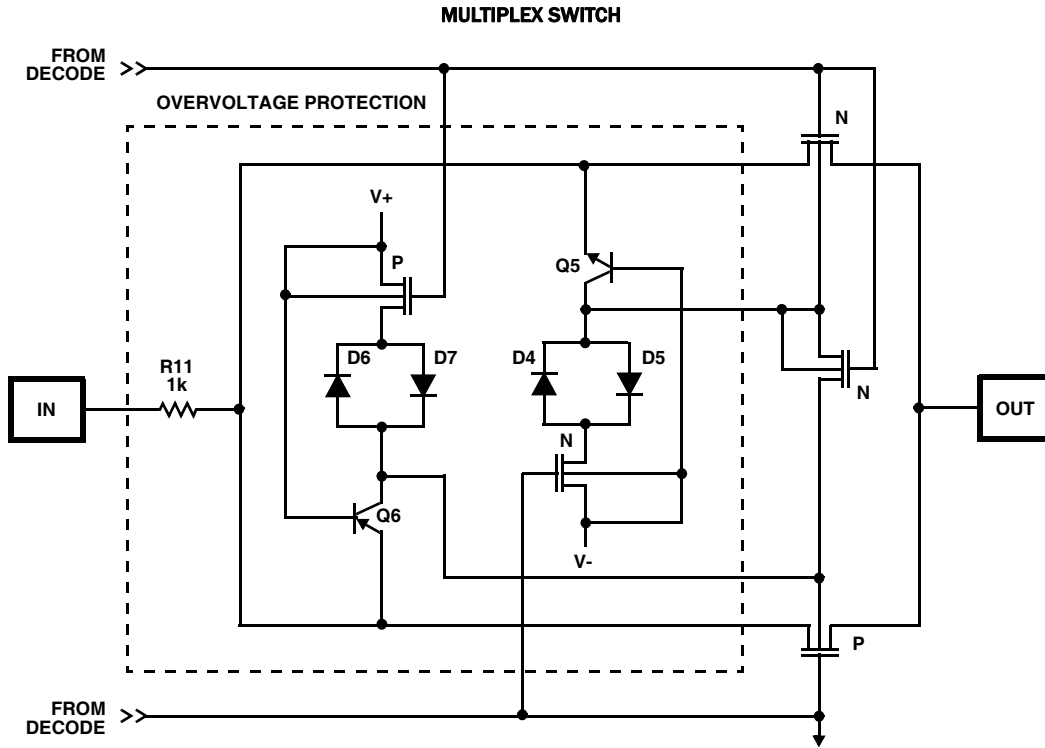

Typical Performance Curves

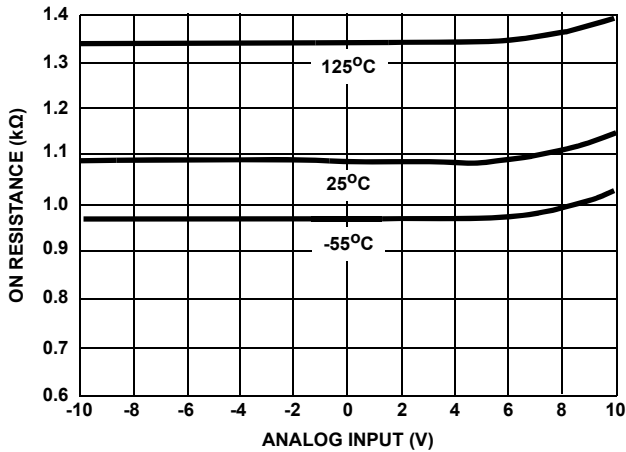

FIGURE 1. ON RESISTANCE vs ANALOG INPUT VOLTAGE

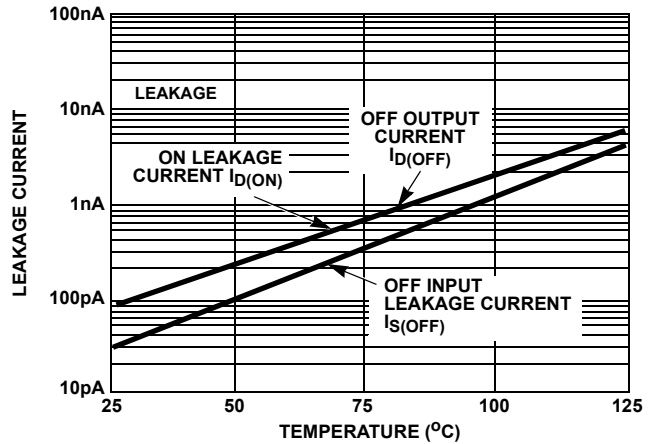

FIGURE 2. LEAKAGE CURRENT vs TEMPERATURE

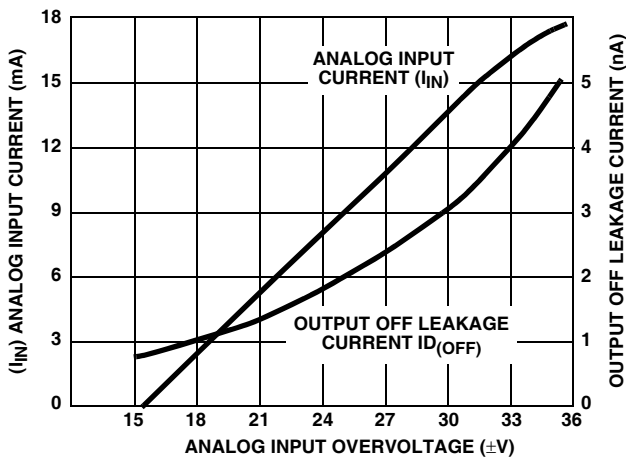

FIGURE 3. ANALOG INPUT OVERVOLTAGE CHARACTERISTICS

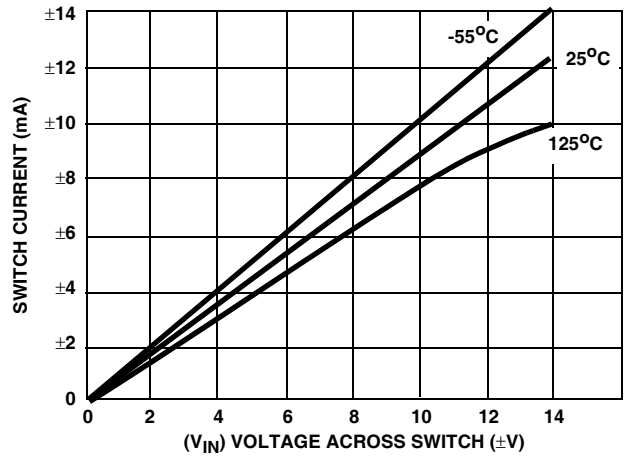

FIGURE 4. ON CHANNEL CURRENT vs VOLTAGE

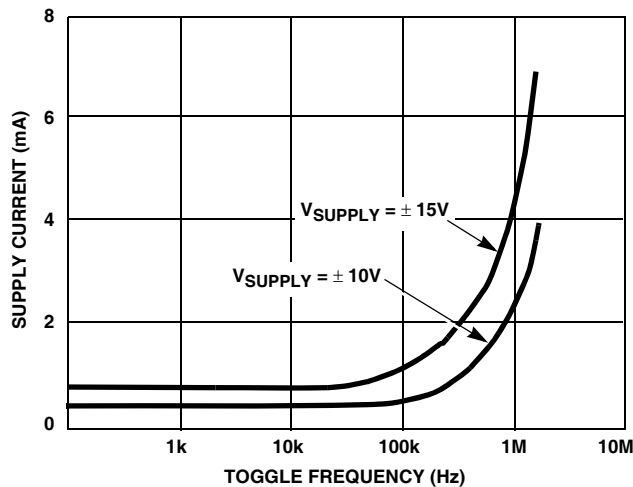

FIGURE 5. SUPPLY CURRENT vs TOGGLE FREQUENCY

HI-548/883, HI-549/883

Die Characteristics

DIE DIMENSIONS:

83 mils x 108 mils x 19 mils

METALLIZATION:

Type: Al

Thickness: $16\text{k}\text{\AA} \pm 2\text{k}\text{\AA}$

GLASSIVATION:

Type: Nitride

Thickness: $7\text{k}\text{\AA} \pm 0.7\text{k}\text{\AA}$

WORST CASE CURRENT DENSITY:

$1.4 \times 10^5 \text{ A/cm}^2$

TRANSISTOR COUNT:

HI-548/883 - 253

HI-549/883 - 253

PROCESS:

CMOS-DI

Metallization Mask Layouts

HI-548/883

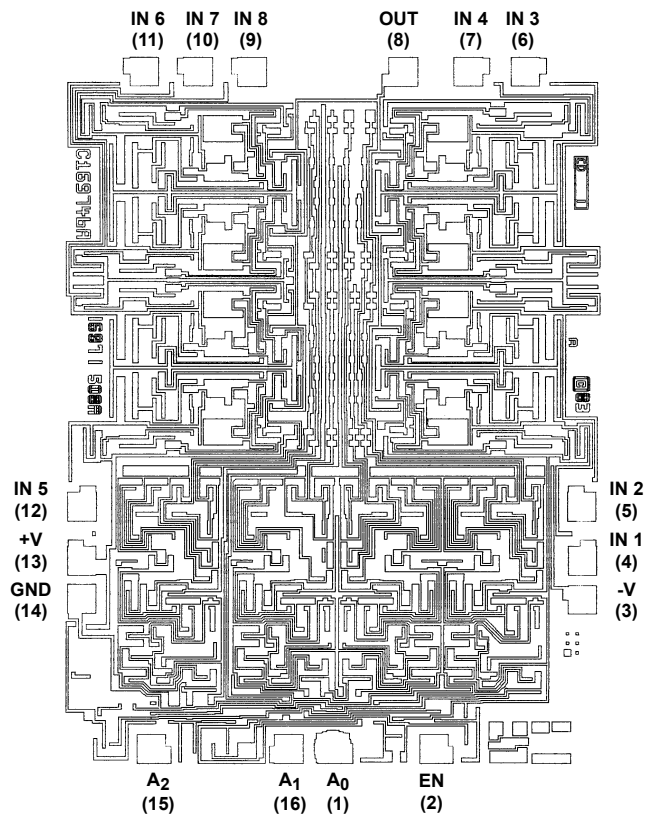

HI-549/883

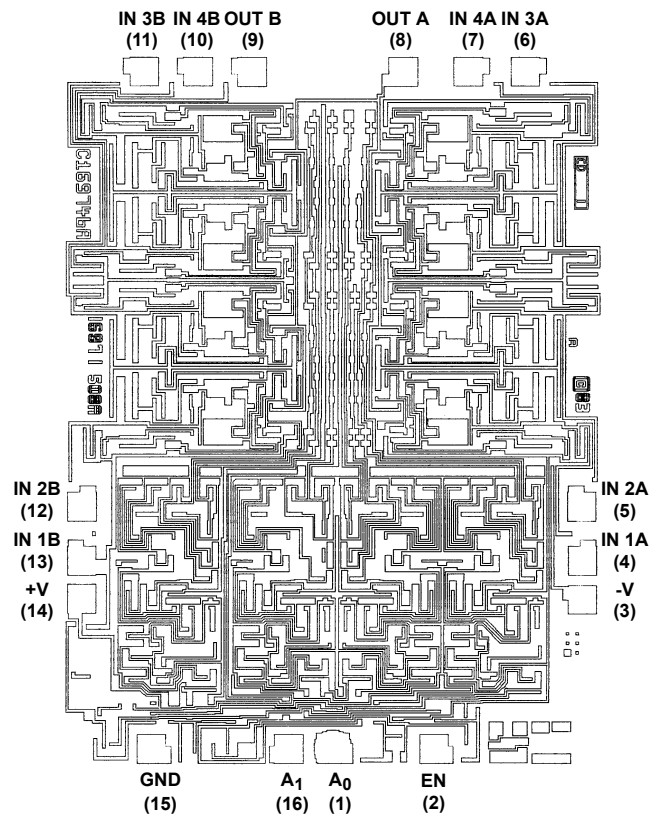

NOTE: Pad numbers correspond to CerDIP numbers only.

Ceramic Dual-In-Line Frit Seal Packages (CERDIP)

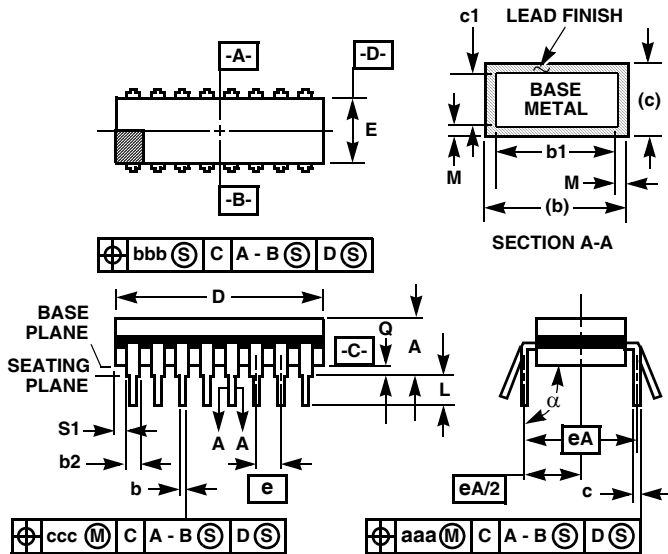

NOTES:

1. Index area: A notch or a pin one identification mark shall be located adjacent to pin one and shall be located within the shaded area shown. The manufacturer's identification shall not be used as a pin one identification mark.
2. The maximum limits of lead dimensions b and c or M shall be measured at the centroid of the finished lead surfaces, when solder dip or tin plate lead finish is applied.
3. Dimensions b1 and c1 apply to lead base metal only. Dimension M applies to lead plating and finish thickness.
4. Corner leads (1, N, N/2, and N/2+1) may be configured with a partial lead paddle. For this configuration dimension b3 replaces dimension b2.
5. This dimension allows for off-center lid, meniscus, and glass overrun.
6. Dimension Q shall be measured from the seating plane to the base plane.
7. Measure dimension S1 at all four corners.
8. N is the maximum number of terminal positions.
9. Dimensioning and tolerancing per ANSI Y14.5M - 1982.
10. Controlling dimension: INCH.

F16.3 MIL-STD-1835 GDIP1-T16 (D-2, CONFIGURATION A) 16 LEAD CERAMIC DUAL-IN-LINE FRIT SEAL PACKAGE

SYMBOL	INCHES		MILLIMETERS		NOTES
	MIN	MAX	MIN	MAX	
A	-	0.200	-	5.08	-
b	0.014	0.026	0.36	0.66	2
b1	0.014	0.023	0.36	0.58	3
b2	0.045	0.065	1.14	1.65	-
b3	0.023	0.045	0.58	1.14	4
c	0.008	0.018	0.20	0.46	2
c1	0.008	0.015	0.20	0.38	3
D	-	0.840	-	21.34	5
E	0.220	0.310	5.59	7.87	5
e	0.100 BSC		2.54 BSC		-
eA	0.300 BSC		7.62 BSC		-
eA/2	0.150 BSC		3.81 BSC		-
L	0.125	0.200	3.18	5.08	-
Q	0.015	0.060	0.38	1.52	6
S1	0.005	-	0.13	-	7
α	90°	105°	90°	105°	-
aaa	-	0.015	-	0.38	-
bbb	-	0.030	-	0.76	-
ccc	-	0.010	-	0.25	-
M	-	0.0015	-	0.038	2, 3
N	16		16		8

Rev. 0 4/94

For additional products, see www.intersil.com/product_tree

Intersil products are manufactured, assembled and tested utilizing ISO9000 quality systems as noted in the quality certifications found at www.intersil.com/design/quality

Intersil products are sold by description only. Intersil Corporation reserves the right to make changes in circuit design, software and/or specifications at any time without notice. Accordingly, the reader is cautioned to verify that data sheets are current before placing orders. Information furnished by Intersil is believed to be accurate and reliable. However, no responsibility is assumed by Intersil or its subsidiaries for its use; nor for any infringements of patents or other rights of third parties which may result from its use. No license is granted by implication or otherwise under any patent or patent rights of Intersil or its subsidiaries.

For information regarding Intersil Corporation and its products, see www.intersil.com

Ceramic Leadless Chip Carrier Packages (CLCC)

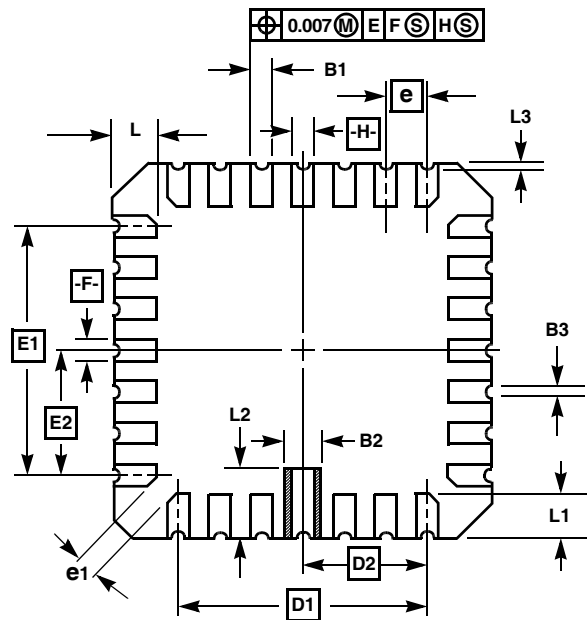
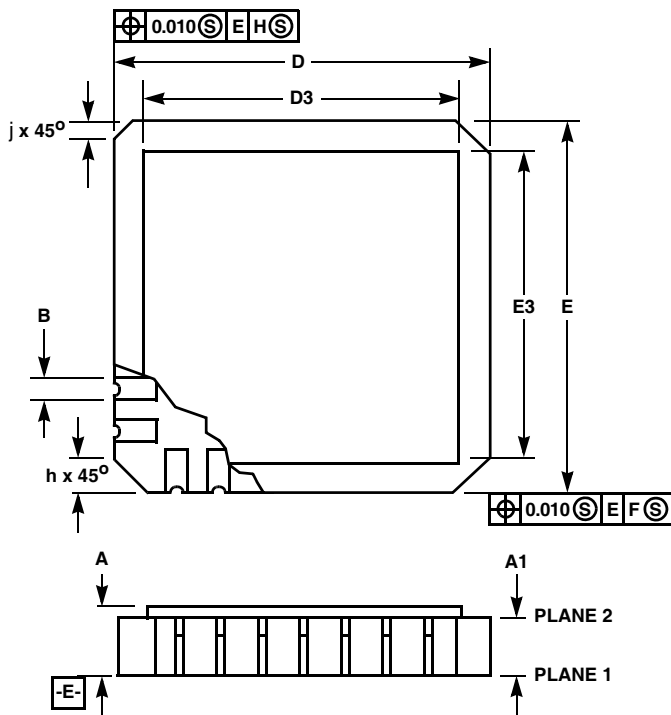

J20.A MIL-STD-1835 CQCC1-N20 (C-2) 20 PAD CERAMIC LEADLESS CHIP CARRIER PACKAGE

SYMBOL	INCHES		MILLIMETERS		NOTES
	MIN	MAX	MIN	MAX	
A	0.060	0.100	1.52	2.54	6, 7
A1	0.050	0.088	1.27	2.23	-
B	-	-	-	-	-
B1	0.022	0.028	0.56	0.71	2, 4
B2	0.072 REF		1.83 REF		-
B3	0.006	0.022	0.15	0.56	-
D	0.342	0.358	8.69	9.09	-
D1	0.200 BSC		5.08 BSC		-
D2	0.100 BSC		2.54 BSC		-
D3	-	0.358	-	9.09	2
E	0.342	0.358	8.69	9.09	-
E1	0.200 BSC		5.08 BSC		-
E2	0.100 BSC		2.54 BSC		-
E3	-	0.358	-	9.09	2
e	0.050 BSC		1.27 BSC		-
e1	0.015	-	0.38	-	2
h	0.040 REF		1.02 REF		5
j	0.020 REF		0.51 REF		5
L	0.045	0.055	1.14	1.40	-
L1	0.045	0.055	1.14	1.40	-
L2	0.075	0.095	1.91	2.41	-
L3	0.003	0.015	0.08	0.38	-
ND	5		5		3
NE	5		5		3
N	20		20		3

Rev. 0 5/18/94

NOTES:

1. Metallized castellations shall be connected to plane 1 terminals and extend toward plane 2 across at least two layers of ceramic or completely across all of the ceramic layers to make electrical connection with the optional plane 2 terminals.
2. Unless otherwise specified, a minimum clearance of 0.015 inch (0.38mm) shall be maintained between all metallized features (e.g., lid, castellations, terminals, thermal pads, etc.)
3. Symbol "N" is the maximum number of terminals. Symbols "ND" and "NE" are the number of terminals along the sides of length "D" and "E", respectively.
4. The required plane 1 terminals and optional plane 2 terminals (if used) shall be electrically connected.
5. The corner shape (square, notch, radius, etc.) may vary at the manufacturer's option, from that shown on the drawing.
6. Chip carriers shall be constructed of a minimum of two ceramic layers.
7. Dimension "A" controls the overall package thickness. The maximum "A" dimension is package height before being solder dipped.
8. Dimensioning and tolerancing per ANSI Y14.5M-1982.
9. Controlling dimension: INCH.

X-ON Electronics

Largest Supplier of Electrical and Electronic Components

Click to view similar products for [Multiplexer Switch ICs](#) category:

Click to view products by [Renesas](#) manufacturer:

Other Similar products are found below :

[M74HCT4066ADTR2G](#) [ADG506ATE/883B](#) [DG406BDN-T1-E3](#) [JM38510/19004BXA](#) [HEF4051BP](#) [5962-8512704XA](#)
[NLA5223CMUTAG](#) [NLV14051BDG](#) [NLVHC4051ADTR2G](#) [JM38510/19002BXA](#) [016400E](#) [ADV3014KSTZ](#) [PI3V512QE](#) [FSA644UCX](#)
[FSA9591UCX](#) [FSSD07BQX](#) [MAX7356ETG](#) [NLV74HCT4851ADRG](#) [7705201EC](#) [MAX4634ETBT](#) [MAX4578CAP+](#) [PI2SSD3212NCE](#)
[MAX3997ETM+](#) [NLV14052BDTR2G](#) [PI3L100QE](#) [PI3DBS12412AZLEX](#) [PI3V512QEX](#) [MAX4969CTO+](#) [PI3DBS12212AZBEX](#)
[PI3DBS16415ZHEX](#) [MAX7367EUP+T](#) [MAX7369EUP+](#) [MAX7357ETG+T](#) [NLV74HC4053ADR2G](#) [NLVAST4051DTR2G](#)
[PI3DBS12412AZHEX](#) [ADG5209BCPZ-RL7](#) [PS509WEX](#) [PS509QEX](#) [PS508QEX](#) [PS508WEX](#) [ADG5209FBRUZ-RL7](#) [ADG5208FBRUZ-RL7](#) [MAX14984ETG+](#) [MAX14984ETG+T](#) [HV2818/R4X](#) [HV2918/R4X](#) [CBTU02044HEJ](#) [PS508LEX](#) [PS509LEX](#)