

GENERAL DESCRIPTION

The MP2735/MP2736 are low voltage, low on-resistance, dual single-pole, double-throw (SPDT) monolithic CMOS analog switches designed for high performance switching of analog signals. Combining low-power, high speed, low on-resistance, and small package size, the MP2735/MP2736 are ideal for portable and battery power applications.

The MP2735/MP2736 have an operation range from 1.65V to 5.5V single supply. The MP2735 has two separate control pins and two separate SPDT switches. The MP2736 includes an \overline{EN} pin. All switches are at high impedance mode when the \overline{EN} is high.

The MP2735/MP2736 are guaranteed 1.65V logic compatible for $V+ < 3.3V$, allowing the easy interface with low voltage DSP or MCU control logic and ideal for one cell Li-ion battery direct power.

The switch conducts signals within power rails equally well in both directions when on, and blocks up to the power supply level when off. Break-before-make is guaranteed.

The MP2735/MP2736 are offered in a QFN10 package.

FEATURES

- Low Voltage Operation (1.65V to 5.5V)
- Low On-Resistance - R_{ON} : 0.45Ω at 2.7V
- Fast Switching: T_{ON} = 29ns at 2.7V
- T_{OFF} = 23ns at 2.7V
- Latch-Up Current >300mA (JESD78)
- 1.4mm x 1.8mm QFN10 Package
- ESD Human-Body Model ±4000V

APPLICATIONS

- Cellular Phones
- Speaker Headset Switching
- Audio and Video Signal Routing
- PCMCIA Cards
- Battery Powered Systems
- Portable Media Player
- Handheld Test Instruments

TRUTH TABLE

	IN1/2	\overline{EN}	NC1/2	NO1/2
MP2735	0	-	ON	OFF
	1	-	OFF	ON
MP2736	0	1	OFF	OFF
	1	1	OFF	OFF
	0	0	ON	OFF
	1	0	OFF	ON

"MPS" and "The Future of Analog IC Technology" are Registered Trademarks of Monolithic Power Systems, Inc..

FUNCTIONAL BLOCK DIAGRAM PIN CONFIGURATION

MP2735DQG



MP2736DQG

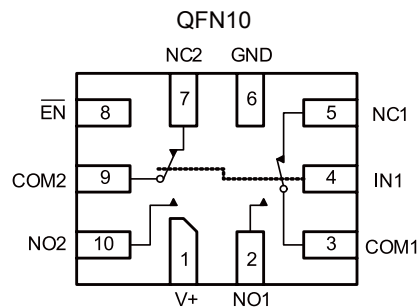

ORDERING INFORMATION

Part Number*	Package	Top Marking	Free Air Temperature (T _A)
MP2735DQG	QFN10 (1.4mm x1.8mm)	$\overline{2T}$	-40°C to +85°C
MP2736DQG		\overline{AM}	

* For Tape & Reel, add suffix -Z (e.g. MP2735DQG-Z).
 For RoHS compliant packaging, add suffix -LF (e.g. MP2735DQG-LF-Z)

PACKAGE REFERENCE



ABSOLUTE MAXIMUM RATINGS

V+ Supply Voltage-0.3V to +6V
 IN/COM/NC/NO Voltage ⁽¹⁾ ... -0.3V to V+ + 0.3V
 Current
 (Any terminal except NO, NC or COM)
 30mA
 Continuous Current (NO, NC or COM)
 ±250mA
 Peak Current
 (Pulsed at 1ms, 10% duty cycle) ±500mA
 Storage Temperature..... -65°C to +150°C
 Power Dissipation (QFN10 ⁽²⁾ ⁽³⁾) 208mW

Notes:

- 1) Signals on NC, or COM or IN exceeding V+ will be clamped by internal diodes. Limit forward diode current to maximum current ratings.
- 2) Derate 4.0mW/°C above 70°C.
- 3) All leads welded or soldered to PC Board.

ELECTRICAL CHARACTERISTICS

V+=3V, ±10%, V_{IN}=0.4 or 1.65V, unless otherwise noted.

Parameter	Symbol	Condition	Min	Typ	Max	Units	
Analog Switch							
Analog Signal Range	V _{analog}	r _{DS(on)} , T _A = -40°C to +85°C	0		V+	V	
On-Resistance	r _{DS(on)}	V+=2.7V, I _{NO/NC} =100mA, V _{COM} =0.5V	T _A = +25°C	0.28	0.45	Ω	
		V+=2.7V, I _{NO/NC} =100mA, V _{COM} =1.5V					
		V+=2.7V, I _{NO/NC} =100mA, V _{COM} =0.5V	T _A = -40°C to +85°C	0.30			
		V+=2.7V, I _{NO/NC} =100mA, V _{COM} =1.5V					
		V+=5.5V, I _{NO/NC} =100mA, V _{COM} =0.9V	T _A = +25°C	0.20	0.30		
		V+=5.5V, I _{NO/NC} =100mA, V _{COM} =2.5V		0.18			
		V+=5.5V, I _{NO/NC} =100mA, V _{COM} =0.9V	T _A = -40°C to +85°C	0.25			
		V+=5.5V, I _{NO/NC} =100mA, V _{COM} =2.5V					
r _{ON} Match	Δr _{on}	V+=2.7V, I _{NO/NC} =100mA, V _{COM} =0.5V/1.5V	T _A = +25°C	0.01	0.02		
		V+=5.5V, I _{NO/NC} =100mA, V _{COM} =0.9V/2.5V					
r _{ON} Flatness	r _{ON} Flatness	V+=2.7V, I _{NO/NC} =100mA, V _{COM} =0.5V/1.5V					
Switch Off Leakage Current	I _{NO/NC(off)}	V+=5.5V, V _{NO/NC} =0.3V/4.0V, V _{COM} =4.0V/0.3V	T _A = +25°C	-40		40	nA
			T _A = -40°C to +85°C	-100		100	
	T _A = +25°C		-40		40		
	T _A = -40°C to +85°C		-100		100		
Channel-On Leakage Current	I _{COM(on)}	V+=5.5V, V _{NO/NC} =V _{COM} =4.0V/0.3V	T _A = +25°C	-40		40	
			T _A = -40°C to +85°C	-150		150	
Digital Control							
Input High Voltage	V _{INH}		T _A = -40°C to +85°C	1.65		V	
Input Low Voltage	V _{INL}						0.4
Input Capacitance	C _{IN}				6		pF
Input Current	I _{INL} or I _{INH}			V _{IN} =0 or V+	-1		1

ELECTRICAL CHARACTERISTICS (continued)
V+=3V, ±10%, V_{IN}=0.4 or 1.65V, unless otherwise noted.

Parameter	Symbol	Condition	Min	Typ	Max	Units	
Dynamic Characteristics							
Break-Before-Make Time	t _{BBM}	V+=3.6V, V _{NO} /V _{NC} =1.5V, R _L =50Ω, C _L =35pF	T _A = +25°C		10		ns
Turn-On Time	t _{ON}				24	36	
Turn-Off Time	t _{OFF}		T _A = -40°C to +85°C			40	
			T _A = +25°C		20	30	
Enable Turn-On Time MP2736 ($\overline{\text{EN}}$)	t _{ON(EN)}		T _A = -40°C to +85°C			35	
			T _A = +25°C		24	36	
Enable Turn-Off Time MP2736 ($\overline{\text{EN}}$)	t _{OFF(EN)}		T _A = -40°C to +85°C			40	
			T _A = +25°C		20	30	
Off-Isolation ⁽⁴⁾	OIRR	R _L =50Ω, C _L =5pF, f=100kHz	T _A = +25°C		-70		dB
Crosstalk ⁽⁴⁾	XTALK				-70		dB
3dB Bandwidth				R _L =50Ω, C _L =5pF		50	
NO, NC Off Capacitance ⁽⁴⁾	C _{NO(off)}	V _{IN} =0V, or V+, f=1MHz	T _A = +25°C		55		pF
	C _{NC(off)}				55		
Channel On Capacitance ⁽⁴⁾	C _{NO(on)}				130		
	C _{NC(on)}				130		
Power Supply							
Power Supply Range	V+			1.65		5.5	V
Power Supply Current	I+	V _{IN} =0 or V+	T _A = -40°C to +85°C	-1		1	μA

Note:

4) Guarantee by design, not subjected to production test.

PIN FUNCTIONS

(MP2735DQG) Pin #	(MP2736DQG) Pin #	Name	Description
1	1	V+	Supply Voltage
2	2	NO1	Normally open I/O port of switch1
3	3	COM1	Common I/O port for NC and NO channels of switch1
4	4	IN1	Channel select signal for switch1. IN1 high, NO1 channel is selected. Otherwise, NC1 channel is selected in default. For MP2736, IN1 controls both switch1 and switch2
5	5	NC1	Normally closed I/O port of switch1
6	6	GND	Ground
7	7	NC2	Normally closed I/O port of switch2
8		IN2	Channel select signal for switch2. IN2 high, NO2 channel is selected. Otherwise, NC2 channel is selected in default
	8	$\overline{\text{EN}}$	Enable for two channels, active low
9	9	COM2	Common I/O port for NC and NO channels of switch2
10	10	NO2	Normally open I/O port of switch2

TYPICAL PERFORMANCE CHARACTERISTICS

$T_A = +25^\circ\text{C}$, unless otherwise noted.

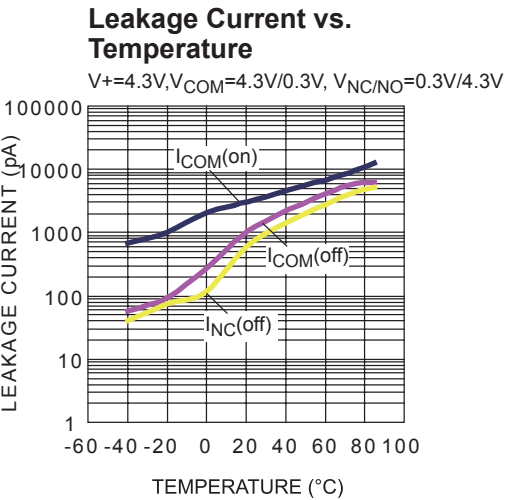
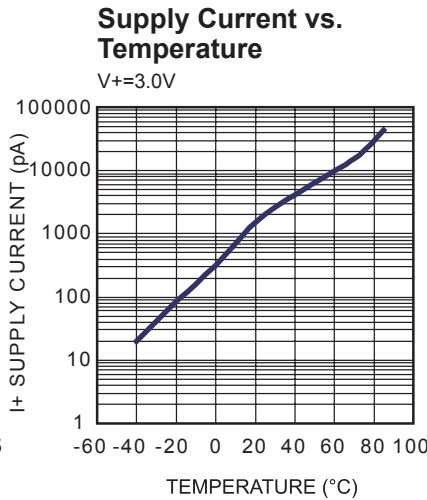
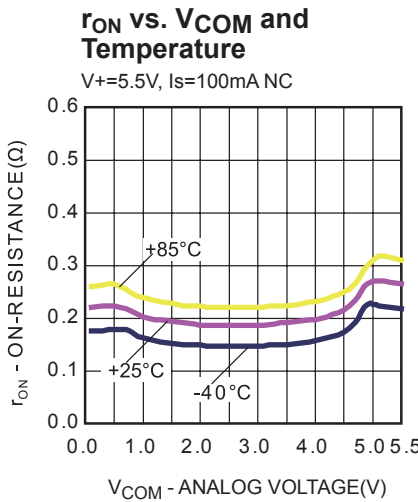
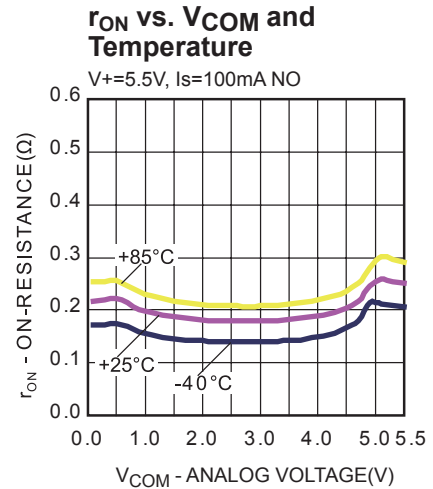
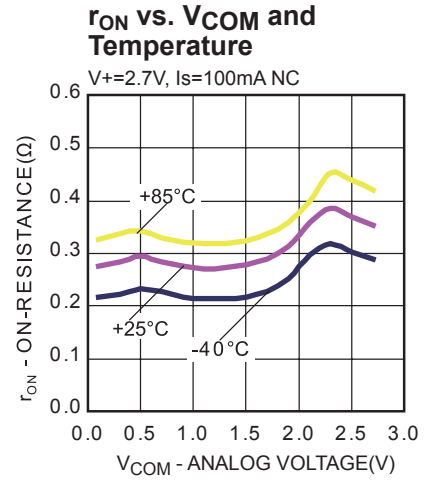
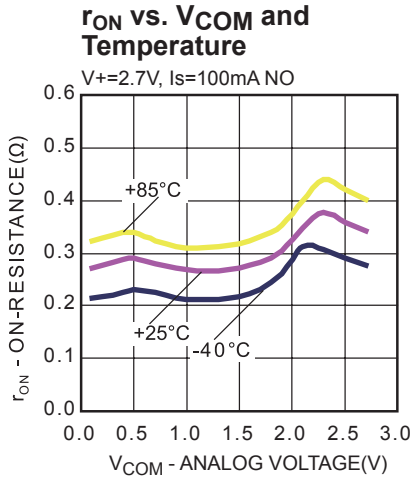
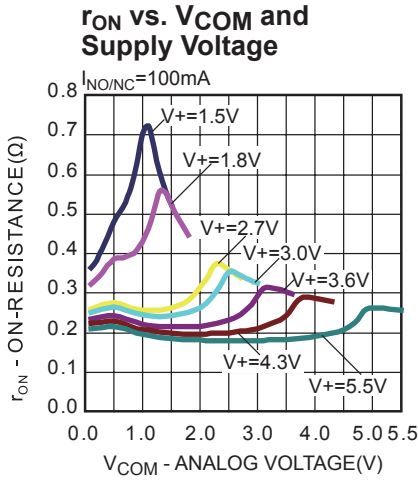

TYPICAL PERFORMANCE CHARACTERISTICS (continued)

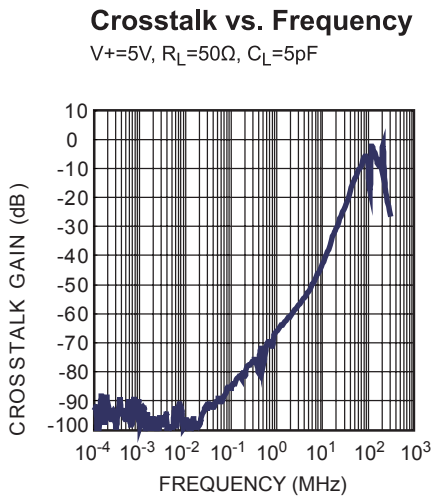
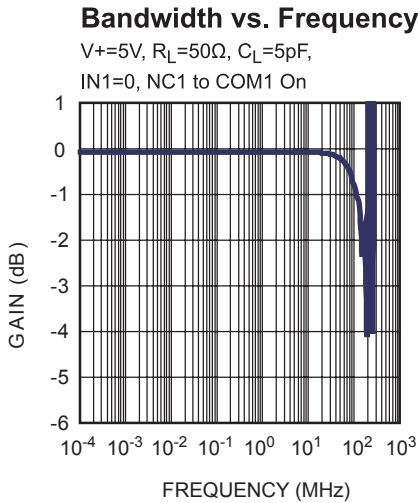
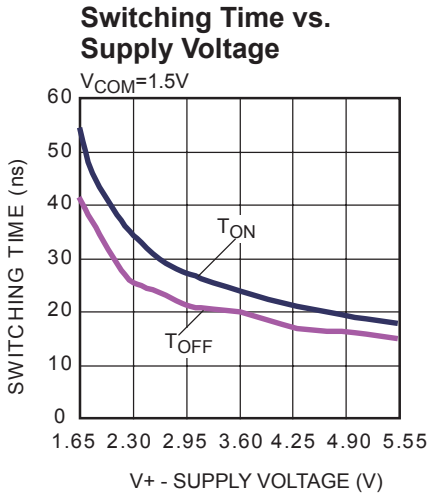
 T_A = +25°C, unless otherwise noted.

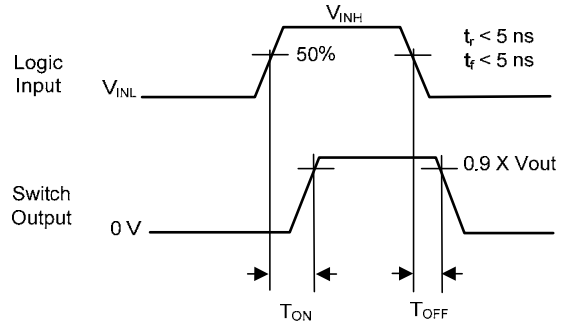
TEST CIRCUITS

C_L (includes fixture and stray capacitance)

$$V_{out} = V_{COM} \left(\frac{R_L}{R_L + R_{ON}} \right)$$

Logic "1" = Switch on
Logic input waveforms inverted for switches that have the opposite logic sense.

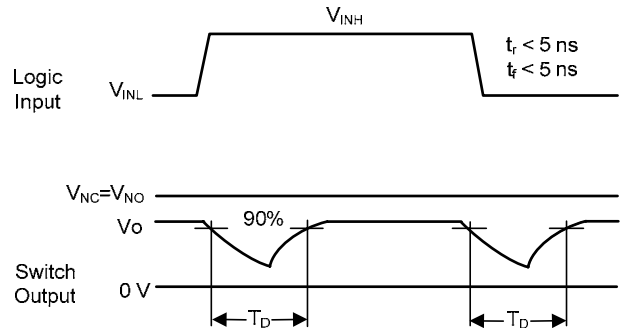
Figure 1 — Switching Time

C_L (includes fixture and stray capacitance)

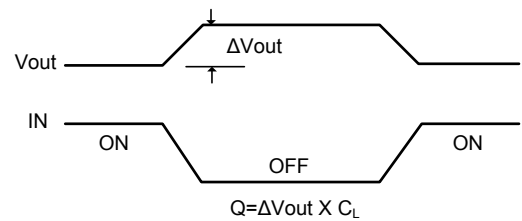
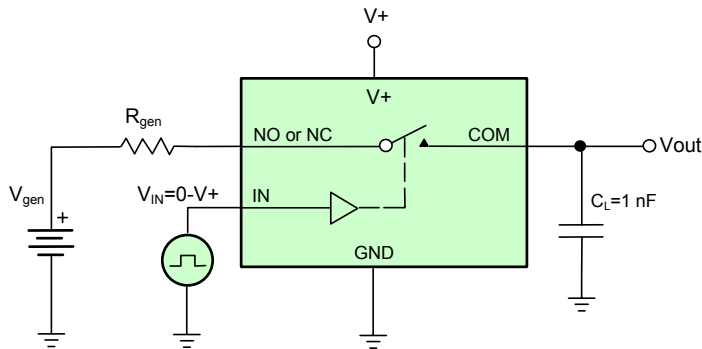
Figure 2 — Break-Before-Make Interval

IN depends on switch configuration: input polarity determined by sense of switch.

Figure 3 — Charge Injection

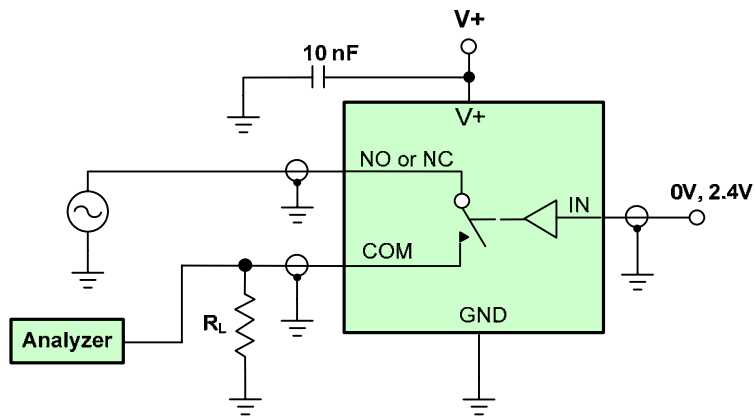

$$\text{Off Isolation} = 20 \log \frac{V_{\text{COM}}}{V_{\text{NO/NC}}}$$

Figure 4 — Off-Isolation

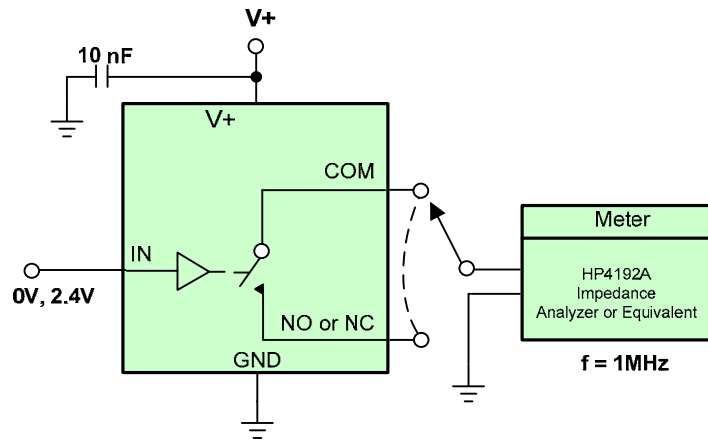
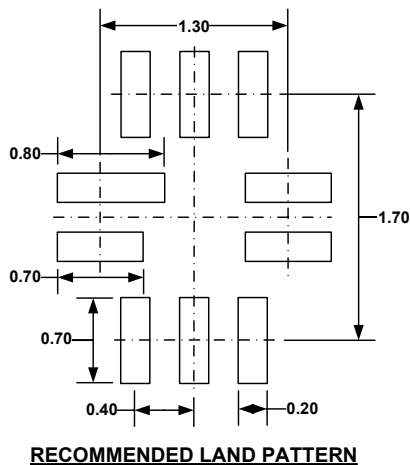
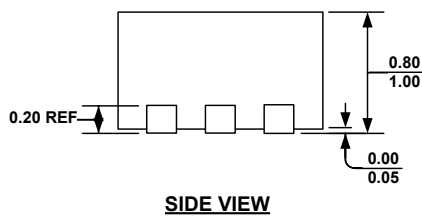
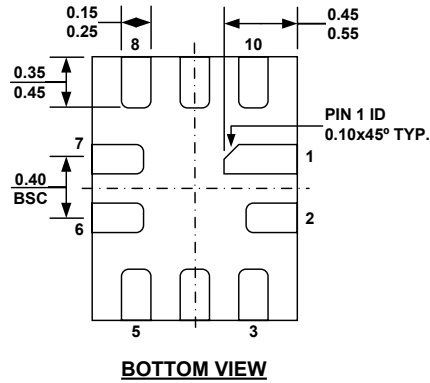
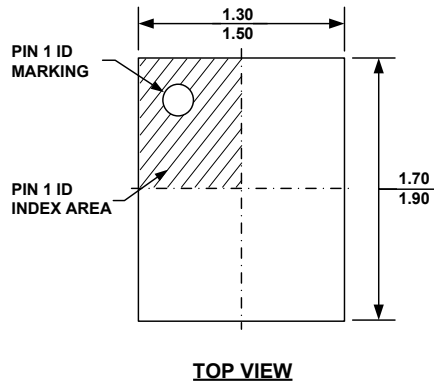

Figure 5 — Channel Off/On Capacitance

PACKAGE INFORMATION

PACKAGE OUTLINE DRAWING FOR 10L FCQFN (1.4x1.8mm) MF-PO-D-0084 revision 0.0



NOTE:

- 1) ALL DIMENSIONS ARE IN MILLIMETERS.
- 2) EXPOSED PADDLE SIZE DOES NOT INCLUDE MOLD FLASH.
- 3) LEAD COPLANARITY SHALL BE 0.10 MILLIMETER MAX.
- 4) JEDEC REFERENCE IS MO-220.
- 5) DRAWING IS NOT TO SCALE.

NOTICE: The information in this document is subject to change without notice. Please contact MPS for current specifications. Users should warrant and guarantee that third party Intellectual Property rights are not infringed upon when integrating MPS products into any application. MPS will not assume any legal responsibility for any said applications.

X-ON Electronics

Largest Supplier of Electrical and Electronic Components

Click to view similar products for [Analog Switch ICs](#) category:

Click to view products by [Monolithic Power Systems](#) manufacturer:

Other Similar products are found below :

[DG9233EDY-GE3](#) [NLAS4684FCTCG](#) [NLAS5223BLMNR2G](#) [NLV74HC4066ADR2G](#) [MC74HC4067ADTG](#) [NLX2G66DMUTCG](#)
[NS5A4684SMNTAG](#) [732480R](#) [733995E](#) [425541DB](#) [425528R](#) [099044FB](#) [FSA221UMX](#) [MAX4888ETI+T](#) [MAX4968CEXB+](#)
[MAX4760EWX+T](#) [NLAS3799BMNR2G](#) [NLAS5123MNR2G](#) [NLAS5213AMUTAG](#) [NLAS7222AMTR2G](#) [MAX14807ECB+](#)
[MAX4968ECM+](#) [NLV14066BDG](#) [LC78615E-01US-H](#) [PI5A4599BCEX](#) [PI5A3157BZUEX](#) [ADG613SRUZ-EP](#) [NLAS4717EPFCT1G](#)
[PI5A3167CCEX](#) [MAX4744ELB+T](#) [MAX4802ACXZ+](#) [DG4051EEN-T1-GE4](#) [SLAS3158MNR2G](#) [PI5A3157BC6EX](#) [PI5A392AQE](#)
[MAX4744HELB+T](#) [PI5A4157ZUEX](#) [MC74HC4067ADTR2G](#) [PI5A4158ZAEX](#) [PI5A3166TAEX](#) [MAX4901EBL+T](#) [MAX14510EEVB+T](#)
[PI3A3899ZTEX](#) [MAX4996ETG+T](#) [MAX4889AETO+T](#) [MAX14508EEVB+T](#) [MAX4701ETE+T](#) [MAX4996LETG+T](#) [NLX2G66FCTAG](#)
[HI1-5051-2](#)