

EE-SX47/67 NEW

Photomicrosensor with 50- to 100-mA direct switching capacity for built-in application.

- Series includes models that enable switching between dark-ON and light-ON operation.
- Response frequency as high as 1 kHz.
- Easy operation monitoring with bright light indicator.
- Wide operating voltage range: 5 to 24 VDC
- Models in which the light indicator turns ON for dark-ON operation are also available.
- A wide range of variations in eight different shapes.
- Flexible robot cable is provided as a standard feature. *2



Be sure to read *Safety Precautions* on page 8.

*1. Only the EE-SX67 Series has pre-wired models.
*2. Pre-wired models only.

Ordering Information

Connector models









Infrared light

Appearance	Sensing method	Connect-ing method	Sensing distance	Output configuration	Indicator mode	Model	
						NPN output	PNP output
Standard 	Through-beam type (with slot)	Connector (4 poles)	 5 mm (slot width)	Dark-ON/Light-ON (selectable) *3	Incident light	EE-SX670	EE-SX670P
					No incident light	EE-SX670A	EE-SX670R
				Light-ON	Incident light	EE-SX470	EE-SX470P
L-shaped 				Dark-ON/Light-ON (selectable) *3	Incident light	EE-SX671	EE-SX671P
					No incident light	EE-SX671A	EE-SX671R
				Light-ON	Incident light	EE-SX471	EE-SX471P
T-shaped 				Dark-ON/Light-ON (selectable) *3	Incident light	EE-SX672	EE-SX672P
					No incident light	EE-SX672A	EE-SX672R
				Light-ON	Incident light	EE-SX472	EE-SX472P
Close-mounting 	Dark-ON/Light-ON (selectable) *3	Incident light	EE-SX673	EE-SX673P			
		No incident light	EE-SX673A	EE-SX673R			
Close-mounting 	Dark-ON/Light-ON (selectable) *3	Incident light	EE-SX473	EE-SX473P			
		No incident light	EE-SX674	EE-SX674P			
	Light-ON	Incident light	EE-SX674A	EE-SX674R			
Light-ON	Incident light	EE-SX474	EE-SX474P				
	Dark-ON/Light-ON (selectable) *3	Incident light	EE-SX675	EE-SX675P			
			NEW	NEW			
T-shaped, slot center: 10 mm 	Dark-ON/Light-ON (selectable) *3	Incident light	EE-SX676	EE-SX676P			
			NEW	NEW			
F-shaped 	Dark-ON/Light-ON (selectable) *3	Incident light	EE-SX677	EE-SX677P			
			NEW	NEW			
R-shaped 	Dark-ON/Light-ON (selectable) *3	Incident light	EE-SX677	EE-SX677P			
			NEW	NEW			

*3. These models can be used as Light-ON when the L terminal and positive (+) terminal are connected to each other. To use them as Dark-ON, do not connect these terminals to each other. When used at light-ON, it is useful to select the connector EE-1001-1. The L terminal and positive (+) terminal of this connector are short-circuited in advance.

Pre-wired Models and Models with Junction Connectors

 Infrared light

Appearance	Sensing method	Sensing distance	Output configuration	Indicator mode	Connecting method	Model	
						NPN output	PNP output
Standard 	Through-beam type (with slot)	 5 mm (slot width)	Dark-ON/ Light-ON (selectable) *	Incident light	Pre-wired models (1 m)	EE-SX670-WR NEW	EE-SX670P-WR NEW
					Models with junction connectors (0.1 m)	EE-SX670-C1 J-R NEW	EE-SX670P-C1 J-R NEW
L-shaped 					Pre-wired models (1 m)	EE-SX671-WR NEW	EE-SX671P-WR NEW
					Models with junction connectors (0.1 m)	EE-SX671-C1 J-R NEW	EE-SX671P-C1 J-R NEW
T-shaped, slot center: 7 mm 					Pre-wired models (1 m)	EE-SX672-WR NEW	EE-SX672P-WR NEW
					Models with junction connectors (0.1 m)	EE-SX672-C1 J-R NEW	EE-SX672P-C1 J-R NEW
Close-mounting 					Pre-wired models (1 m)	EE-SX673-WR NEW	EE-SX673P-WR NEW
					Models with junction connectors (0.1 m)	EE-SX673-C1 J-R NEW	EE-SX673P-C1 J-R NEW
Close-mounting 					Pre-wired models (1 m)	EE-SX674-WR NEW	EE-SX674P-WR NEW
					Models with junction connectors (0.1 m)	EE-SX674-C1 J-R NEW	EE-SX674P-C1 J-R NEW
T-shaped, slot center: 10 mm 					Pre-wired models (1 m)	EE-SX675-WR NEW	EE-SX675P-WR NEW
					Models with junction connectors (0.1 m)	EE-SX675-C1 J-R NEW	EE-SX675P-C1 J-R NEW
F-shaped 					Pre-wired models (1 m)	EE-SX676-WR NEW	EE-SX676P-WR NEW
					Models with junction connectors (0.1 m)	EE-SX676-C1 J-R NEW	EE-SX676P-C1 J-R NEW
R-shaped 					Pre-wired models (1 m)	EE-SX677-WR NEW	EE-SX677P-WR NEW
					Models with junction connectors (0.1 m)	EE-SX677-C1 J-R NEW	EE-SX677P-C1 J-R NEW

* These models can be used as Light-ON when the L line and positive (+) line are connected to each other. To use them as Dark-ON, do not connect these lines to each other.

Accessories for Models with Connectors (Order Separately)

Type	Cable length	Model	Remarks
Connector		EE-1001	
		EE-1001-1	L terminal and positive (+) terminal are already short-circuited.
		EE-1009	
Connector with Cable	1 m	EE-1006	
		EE-1010	
	2 m	EE-1006	
		EE-1010	
Connector with Robot Cable	1 m	EE-1010-R	
	2 m	EE-1010-R	
Connector Hold-down Clip		EE-1006A	For EE-1006 only.

Accessories for Models with Junction Connectors (Order Separately)

Type	Cable length	Model	Remarks
Connector with Robot Cable	2m	EE-1016-R-1 NEW	For EE-SX67□-C1 J-R.

EE-SX47/67

Ratings and Specifications

Item	Type	Standard	L-shaped	T-shaped, slot center: 7 mm	Close-mounting		T-shaped, slot center: 10 mm	F-shaped	R-shaped	
	NPN models	Connector	EE-SX670 EE-SX670A EE-SX470	EE-SX671 EE-SX671A EE-SX471	EE-SX672 EE-SX672A EE-SX472	EE-SX673 EE-SX673A EE-SX473	EE-SX674 EE-SX674A EE-SX474	EE-SX675	EE-SX676	EE-SX677
NPN models	Pre-wired models	EE-SX670-WR	EE-SX671-WR	EE-SX672-WR	EE-SX673-WR	EE-SX674-WR	EE-SX675-WR	EE-SX676-WR	EE-SX677-WR	
	Models with junction connectors	EE-SX670-C1J-R	EE-SX671-C1J-R	EE-SX672-C1J-R	EE-SX673-C1J-R	EE-SX674-C1J-R	EE-SX675-C1J-R	EE-SX676-C1J-R	EE-SX677-C1J-R	
	Connector	EE-SX670P EE-SX670R EE-SX470P	EE-SX671P EE-SX671R EE-SX471P	EE-SX672P EE-SX672R EE-SX472P	EE-SX673P EE-SX673R EE-SX473P	EE-SX674P EE-SX674R EE-SX474P	EE-SX675P	EE-SX676P	EE-SX677P	
PNP models	Pre-wired models	EE-SX670P-WR	EE-SX671P-WR	EE-SX672P-WR	EE-SX673P-WR	EE-SX674P-WR	EE-SX675P-WR	EE-SX676P-WR	EE-SX677P-WR	
	Models with junction connectors	EE-SX670P-C1J-R	EE-SX671P-C1J-R	EE-SX672P-C1J-R	EE-SX673P-C1J-R	EE-SX674P-C1J-R	EE-SX675P-C1J-R	EE-SX676P-C1J-R	EE-SX677P-C1J-R	
Sensing distance		5 mm (slot width)								
Sensing object		Opaque: 2 × 0.8 mm min.								
Differential distance		0.025 mm								
Light source		GaAs infrared LED with a peak wavelength of 940 nm								
Indicator *1		Light indicator (red) (turns ON when light is interrupted for models with A or R suffix)								
Supply voltage		5 to 24 VDC ±10%, ripple (p-p): 10% max.								
Current consumption		35 mA max. (NPN models), 30 mA max. (PNP models)								
Control output		NPN open collector: 5 to 24 VDC, 100 mA max. 100 mA load current with a residual voltage of 0.8 V max. 40 mA load current with a residual voltage of 0.4 V max. PNP open collector: 5 to 24 VDC, 50 mA max. 50 mA load current with a residual voltage of 1.3 V max.								
Response frequency *2		1 kHz min. (3 kHz average)								
Ambient illumination		1,000 lx max. with fluorescent light on the surface of the receiver.								
Ambient temperature range		Operating: -25 to +55°C, Storage: -30 to +80°C								
Ambient humidity range		Operating: 5% to 85%, Storage: 5% to 95%								
Vibration resistance		Destruction: 20 to 2,000 Hz (peak acceleration: 100 m/s ²) 1.5-mm double amplitude for 2 h (4-min periods) each in X, Y, and Z directions								
Shock resistance		Destruction: 500 m/s ² for 3 times each in X, Y, and Z directions								
Enclosure rating		IEC60529 IP50								
Connecting method		Special connectors (direct soldering possible), Pre-wired models (Standard cable length: 1 m), Models with junction connectors (Standard cable length: 0.1 m)								
Weight (packaged)	Connector	Approx. 3.1 g	Approx. 3 g	Approx. 2.4 g	Approx. 2.3 g	Approx. 3 g	Approx. 2.7 g	Approx. 2.2 g	Approx. 2.2 g	
	Pre-wired models	Approx. 18.9 g	Approx. 17.3 g	Approx. 17.8 g	Approx. 16.8 g	Approx. 17.1 g	Approx. 18.3 g	Approx. 16.9 g	Approx. 16.9 g	
	Models with junction connectors	Approx. 6.3 g	Approx. 4.7 g	Approx. 5.2 g	Approx. 4.2 g	Approx. 4.5 g	Approx. 5.7 g	Approx. 4.3 g	Approx. 4.3 g	
Material	Case	Polybutylene phthalate (PBT)								
	Cover emitter/receiver	Polycarbonate								

*1. The indicator is a GaP red LED (peak wavelength: 690 nm).

*2. The response frequency was measured by detecting the rotating disk shown at the right.

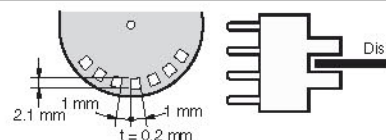

Connector for the EE-SX67 with Junction Connector

Item	Product Model	Connector with Robot Cable
	Appearance	EE-1016-R-1
Contact resistance	25 mΩ max. (at 10 mA DC and 20 mV max.)	
Insertion strength	20 N max.	
Surplus strength (housing holding strength)	15 N min.	
Cable length	2 m	
Ambient temperature range	-25 to 85°C	
Materials	Housing	Nylon
	Contact	Phosphor bronze

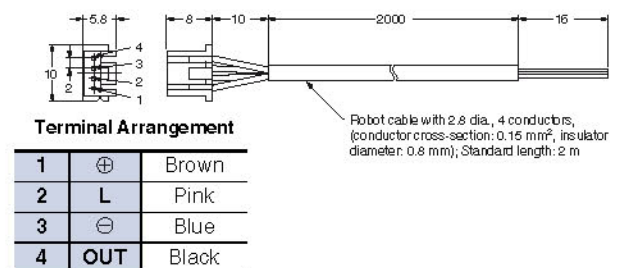

Engineering Data (Typical)

Sensing Position Characteristics

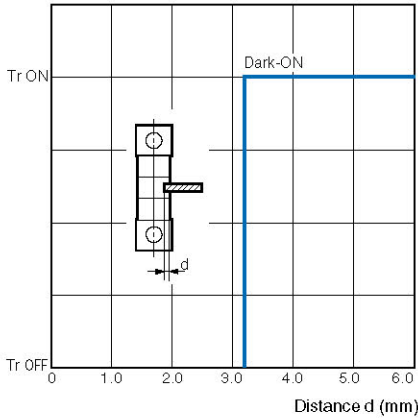

Sensing Position Characteristics

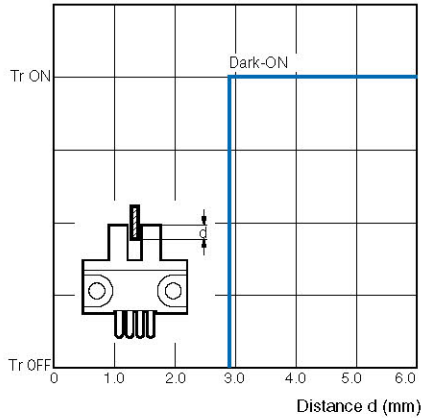

Repeated Sensing Position Characteristics

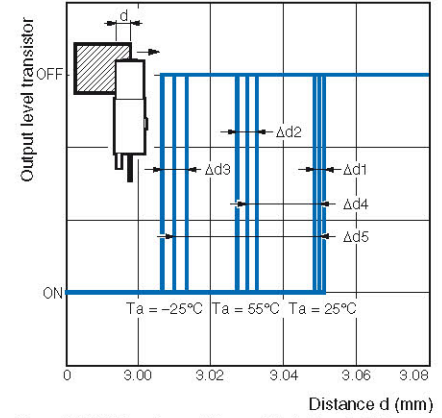

Vcc = 12 V, No. of repetitions: 20, Δd1 = 0.002 mm, Δd2 = 0.004 mm, Δd3 = 0.005 mm, Δd4 = 0.02 mm, Δd5 = 0.04 mm

I/O Circuit Diagrams

NPN Output

Model	Output configuration	Timing chart	Terminal connection	Output circuit
EE-SX67□ EE-SX67□-WR EE-SX67□-C1J-R	Light-ON		Short-circuited between ① terminal and positive ⊕ terminal	
	Dark-ON		Open between ① terminal and positive ⊕ terminal	
EE-SX670A EE-SX671A EE-SX672A EE-SX673A EE-SX674A	Light-ON		Short-circuited between ① terminal and positive ⊕ terminal	
	Dark-ON		Open between ① terminal and positive ⊕ terminal	
EE-SX470 EE-SX471 EE-SX472 EE-SX473 EE-SX474	Light-ON		---	

PNP Output

Model	Output configuration	Timing chart	Terminal connection	Output circuit
EE-SX67□P EE-SX67□P-WR EE-SX67□P-C1J-R	Light-ON		Short-circuited between ① terminal and positive ⊕ terminal	
	Dark-ON		Open between ① terminal and positive ⊕ terminal	
EE-SX670R EE-SX671R EE-SX672R EE-SX673R EE-SX674R	Light-ON		Short-circuited between ① terminal and positive ⊕ terminal	
	Dark-ON		Open between ① terminal and positive ⊕ terminal	
EE-SX470P EE-SX471P EE-SX472P EE-SX473P EE-SX474P	Light-ON		---	

Safety Precautions

Refer to *Warranty and Limitations of Liability*.

⚠ WARNING

This product is not designed or rated for ensuring safety of persons either directly or indirectly. Do not use it for such purposes.



Precautions for Safe Use

● Operating Environment

These Photomicrosensors have an IP50 (conforms to IEC60529) enclosure and do not have a water-proof or dust-proof structure. Therefore, do not use them in applications in which the sensor will be subjected to splashes from water, oil, or any other liquid. Liquid entering the Sensor may result in malfunction.

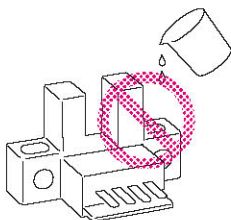

Precautions for Correct Use

Make sure that this product is used within the rated ambient environment conditions.

● Installation

- When direct soldering to the terminals, use the following guidelines.

Soldering Conditions

Item	Temperature	Permissible time	Remarks
Soldering iron	350°C max.	3 s max.	The portion between the base of the terminals and the position 1.5 mm from the terminal base must not be soldered.

- The terminal base uses a polycarbonate resin, which could be deformed by excessive soldering heat, resulting in damage to the product's functionality.

● Lot Numbers and Models

In the right illustration, 376d indicates the lot number and factory where the product was manufactured. Do not include this code with the model number when ordering.

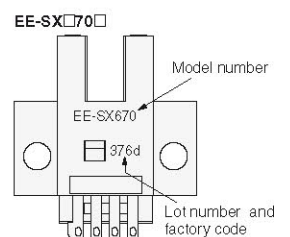

Dimensions

Sensors

EE-SX670/670P
EE-SX670A/670R
EE-SX470/470P



Terminal Arrangement

(1)	⊕	Vcc
(2)	L	L*
(3)	OUT	OUTPUT
(4)	⊖	GND (0 V)

* L Terminal needs no connection for all EE-SX47□ series sensors.

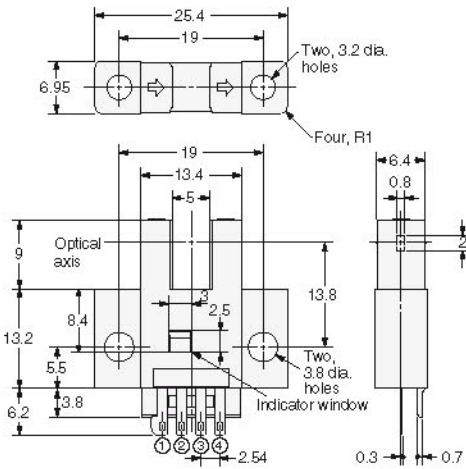

EE-SX671/671P
EE-SX671A/671R
EE-SX471/471P



Terminal Arrangement

(1)	⊕	Vcc
(2)	L	L*
(3)	OUT	OUTPUT
(4)	⊖	GND (0 V)

* L Terminal needs no connection for all EE-SX47□ series sensors.

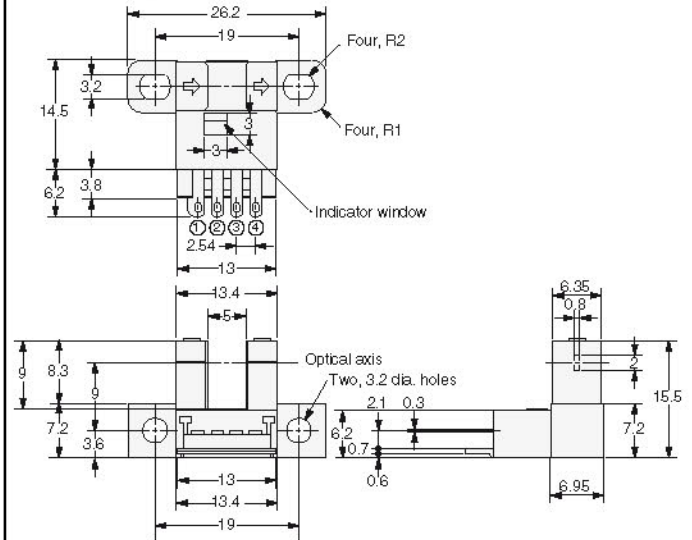

EE-SX672/672P
EE-SX672A/672R
EE-SX472/472P



Terminal Arrangement

(1)	⊕	Vcc
(2)	L	L*
(3)	OUT	OUTPUT
(4)	⊖	GND (0 V)

* L Terminal needs no connection for all EE-SX47□ series sensors.

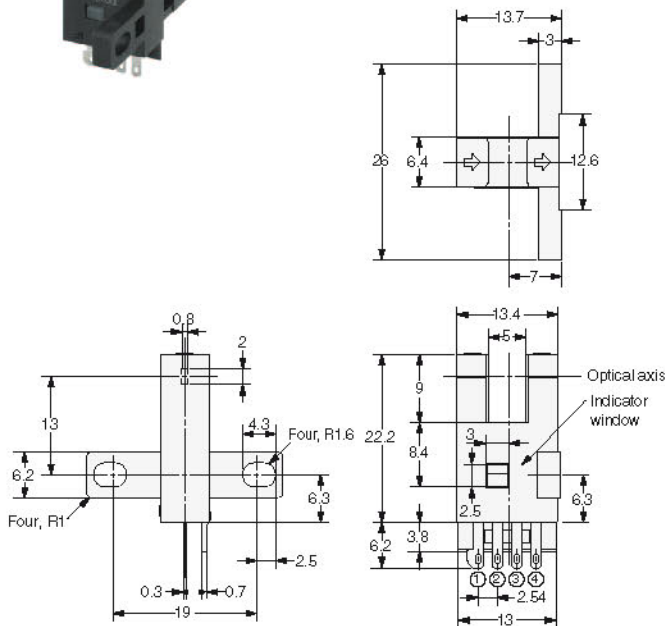

EE-SX673/673P
EE-SX673A/673R
EE-SX473/473P



Terminal Arrangement

(1)	⊕	Vcc
(2)	L	L*
(3)	OUT	OUTPUT
(4)	⊖	GND (0 V)

* L Terminal needs no connection for all EE-SX47□ series sensors.

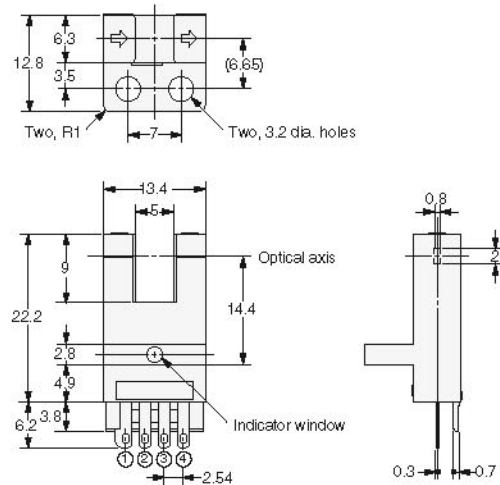

EE-SX47/67

EE-SX674/674P EE-SX674A/674R EE-SX474/474P



Terminal Arrangement

(1)	⊕	Vcc
(2)	L	L*
(3)	OUT	OUTPUT
(4)	⊖	GND (0 V)

* L Terminal needs no connection for all EE-SX47□ series sensors.

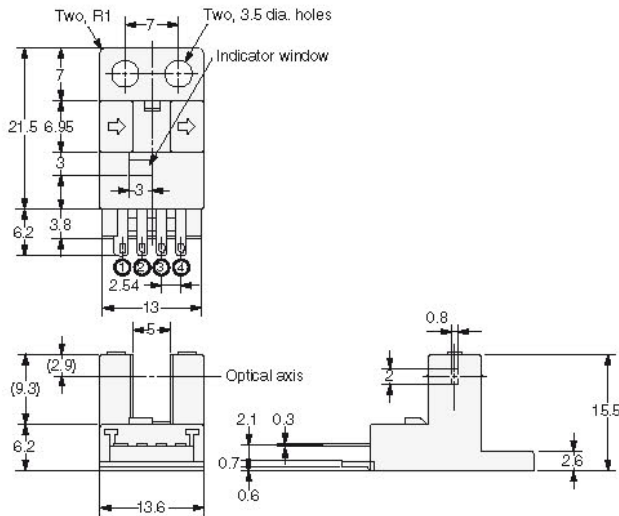

EE-SX675/675P



Terminal Arrangement

(1)	⊕	Vcc
(2)	L	L
(3)	OUT	OUTPUT
(4)	⊖	GND (0 V)

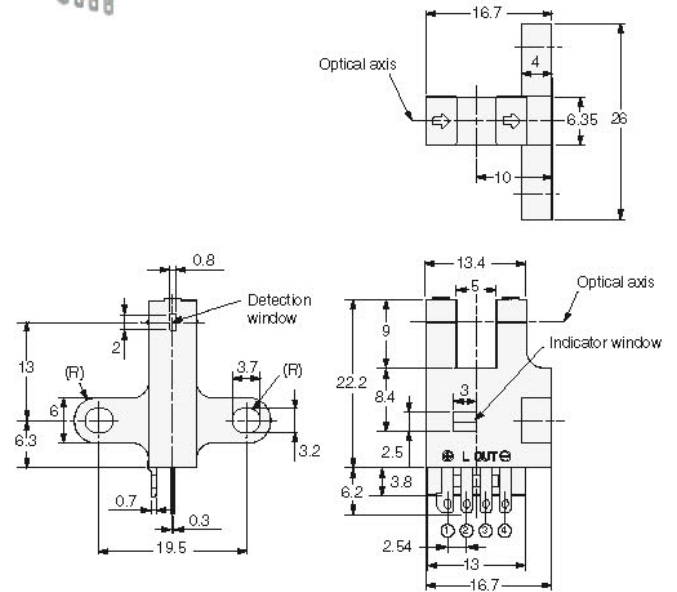

EE-SX676/676P



Terminal Arrangement

(1)	⊕	Vcc
(2)	L	L
(3)	OUT	OUTPUT
(4)	⊖	GND (0 V)

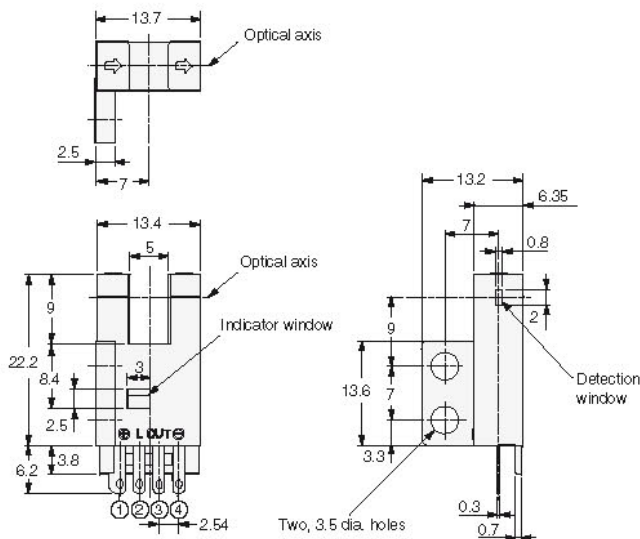

EE-SX677/677P



Terminal Arrangement

(1)	⊕	Vcc
(2)	L	L
(3)	OUT	OUTPUT
(4)	⊖	GND (0 V)

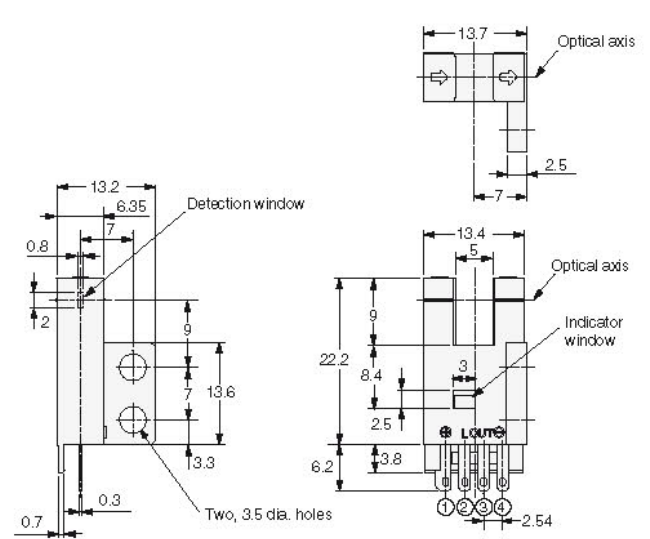

EE-SX670-WR/670P-WR
EE-SX670-C1J-R/670P-C1J-R

Terminal Arrangement

Brown	(1)	Vcc
Pink	(2)	L
Blue	(3)	GND (0 V)
Black	(4)	OUTPUT

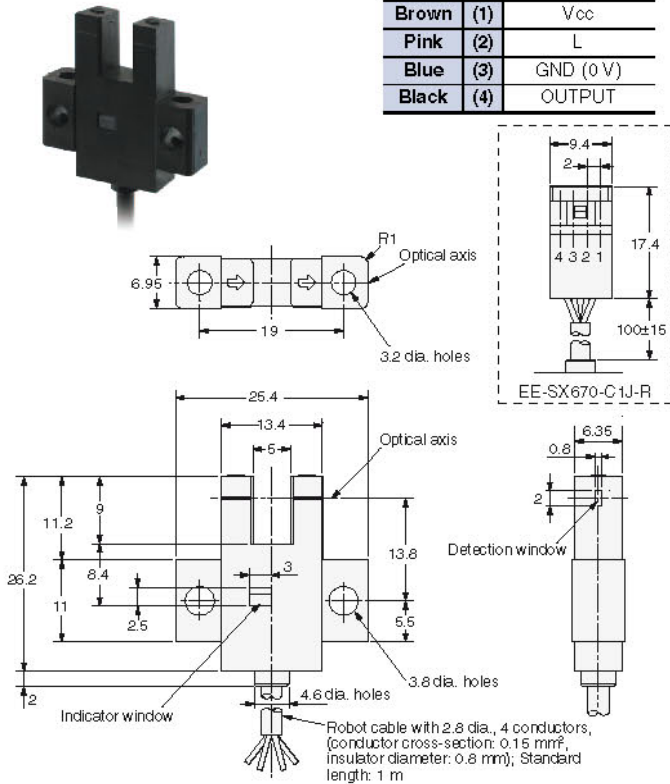

EE-SX671-WR/671P-WR
EE-SX671-C1J-R/671P-C1J-R

Terminal Arrangement

Brown	(1)	Vcc
Pink	(2)	L
Blue	(3)	GND (0 V)
Black	(4)	OUTPUT

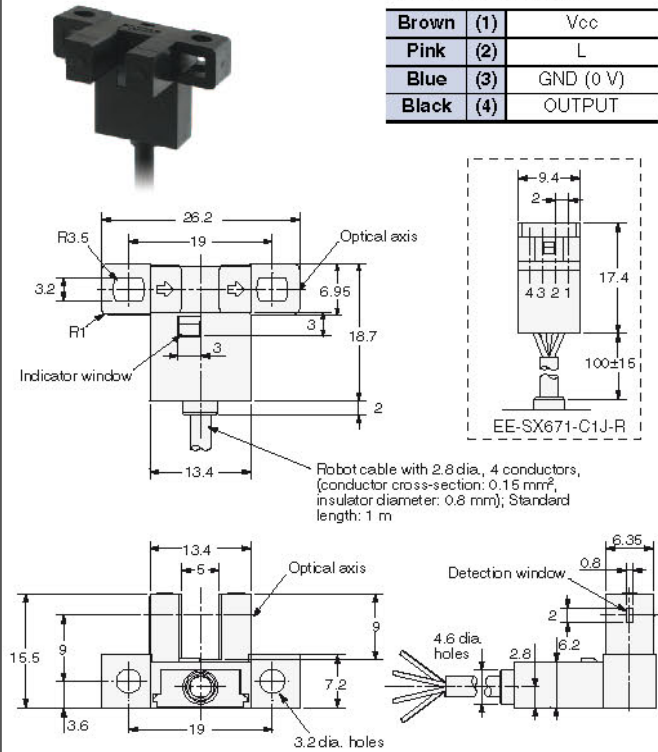

EE-SX672-WR/672P-WR
EE-SX672-C1J-R/672P-C1J-R

Terminal Arrangement

Brown	(1)	Vcc
Pink	(2)	L
Blue	(3)	GND (0 V)
Black	(4)	OUTPUT

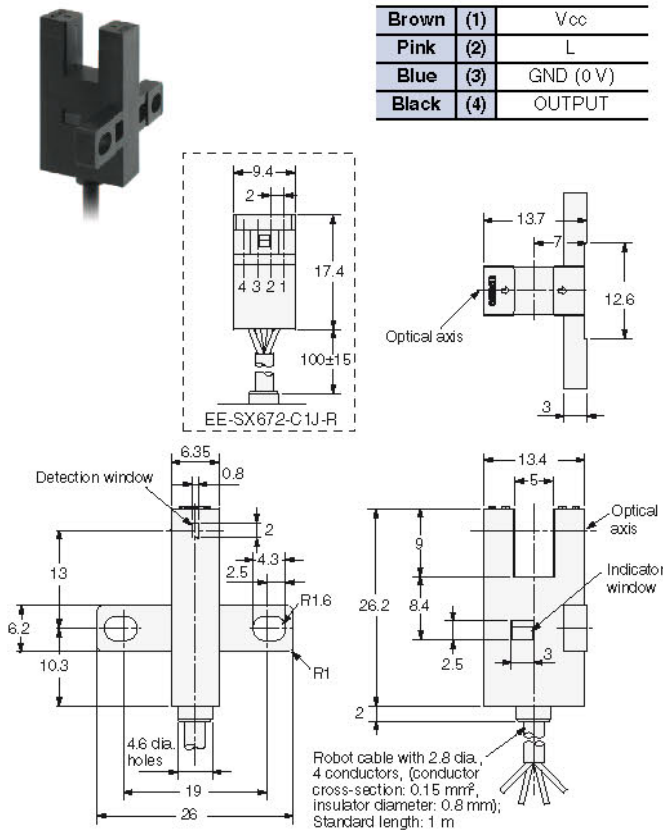

EE-SX673-WR/673P-WR
EE-SX673-C1J-R/673P-C1J-R

Terminal Arrangement

Brown	(1)	Vcc
Pink	(2)	L
Blue	(3)	GND (0 V)
Black	(4)	OUTPUT

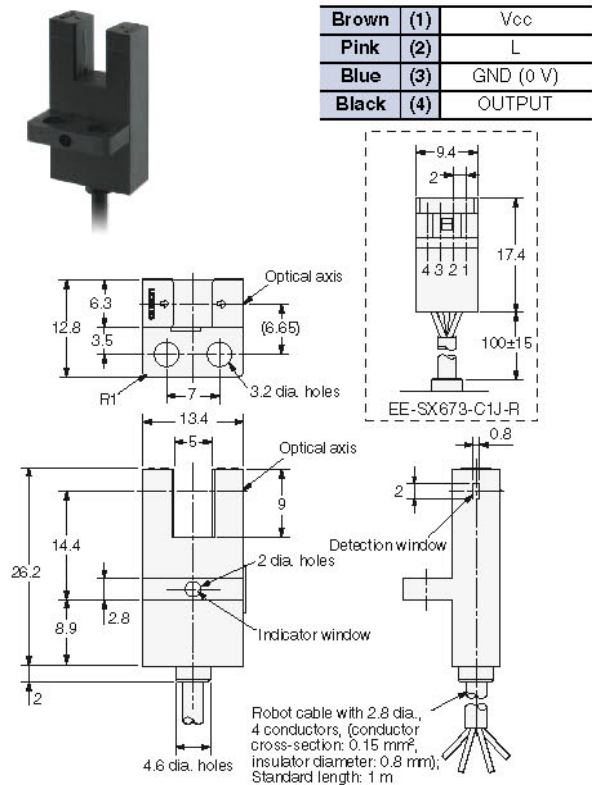

EE-SX47/67

EE-SX674-WR/674P-WR EE-SX674-C1J-R/674P-C1J-R

Terminal Arrangement

Brown (1)	Vcc
Pink (2)	L
Blue (3)	GND (0 V)
Black (4)	OUTPUT

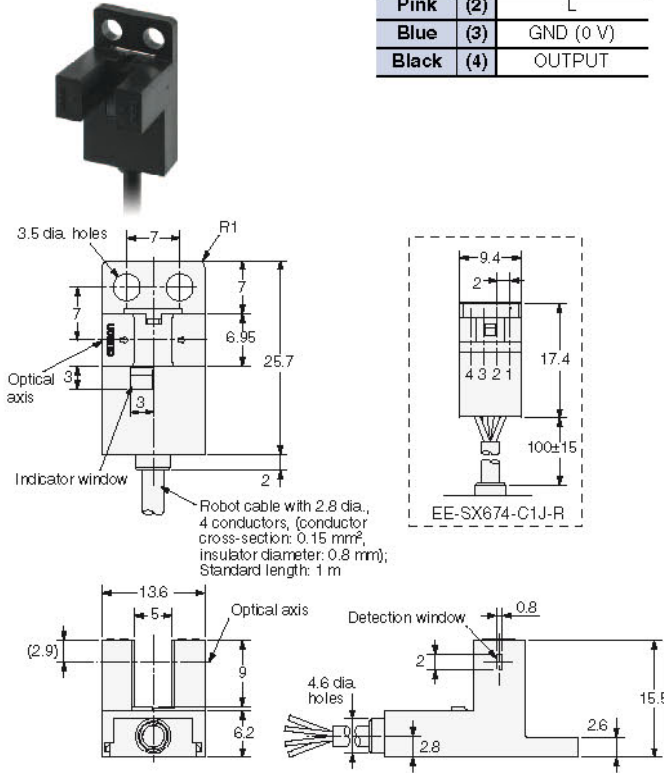

EE-SX675-WR/675P-WR EE-SX675-C1J-R/675P-C1J-R

Terminal Arrangement

Brown (1)	Vcc
Pink (2)	L
Blue (3)	GND (0 V)
Black (4)	OUTPUT

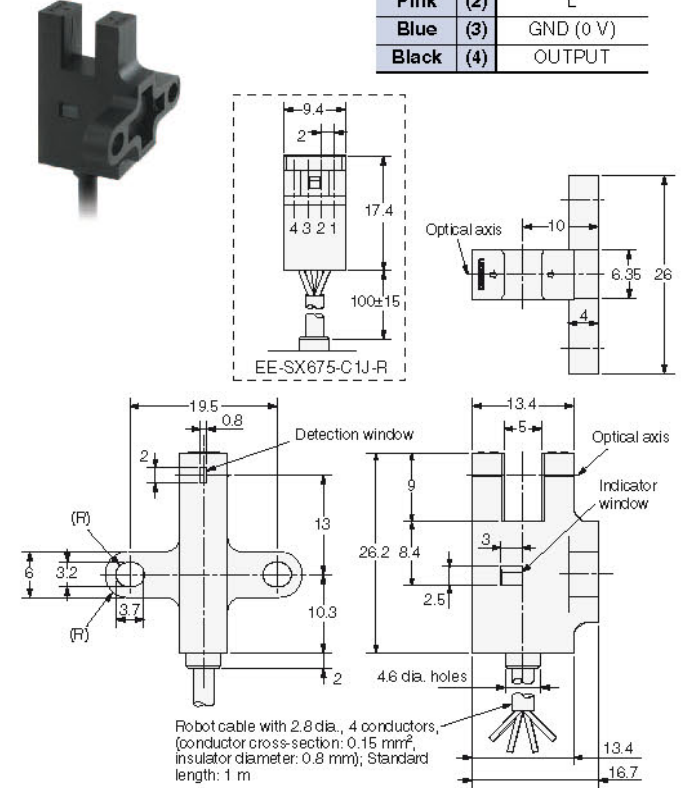

EE-SX676-WR/676P-WR EE-SX676-C1J-R/676P-C1J-R

Terminal Arrangement

Brown (1)	Vcc
Pink (2)	L
Blue (3)	GND (0 V)
Black (4)	OUTPUT

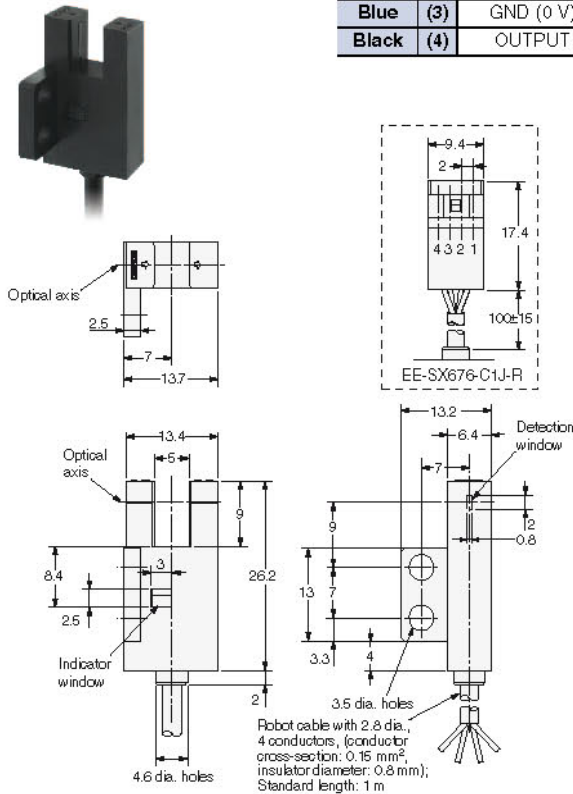

EE-SX677-WR/677P-WR EE-SX677-C1J-R/677P-C1J-R

Terminal Arrangement

Brown (1)	Vcc
Pink (2)	L
Blue (3)	GND (0 V)
Black (4)	OUTPUT

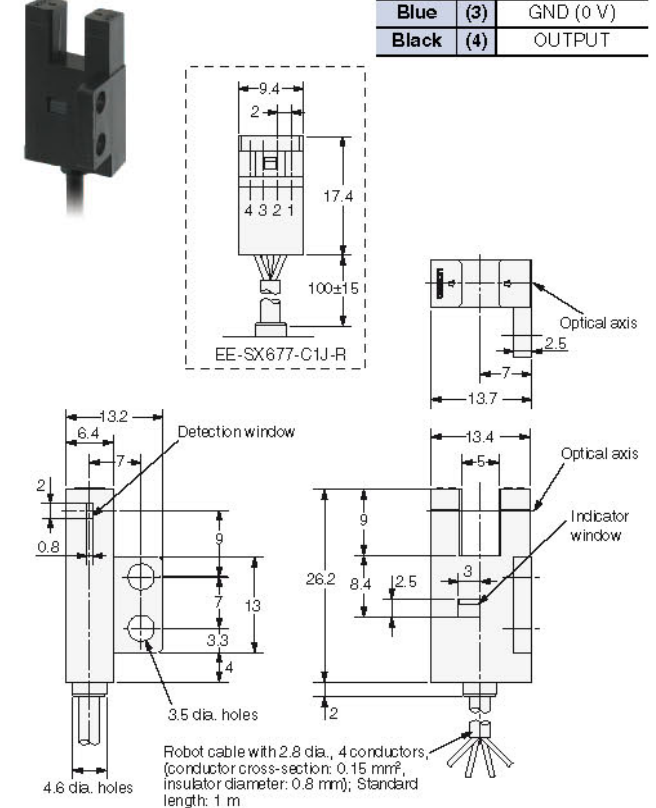

EE-SX47/67 Connector Hold-down Clips

Connector

EE-1001

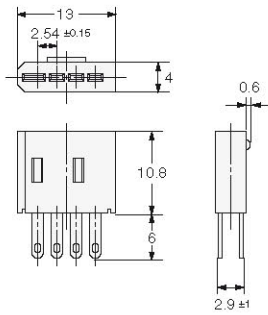

Connector (short-circuited between positive (+) and L terminals)

EE-1001-1

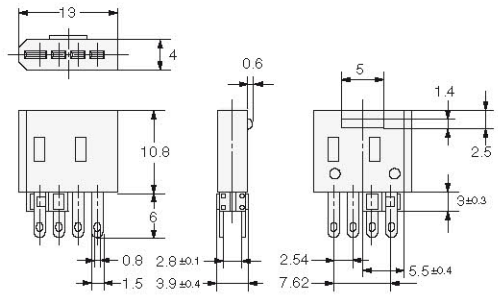

Connector with Cable

EE-1006

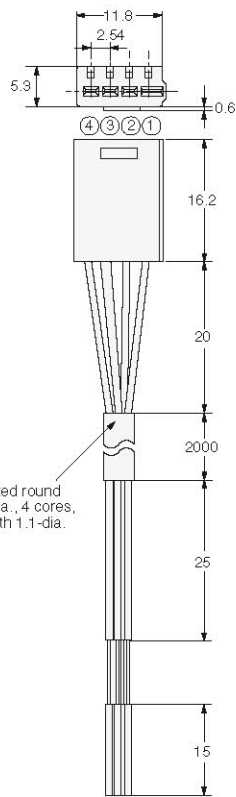

Cable: Vinyl-insulated round cable of 4 dia., 4 cores, (0.2 mm² with 1.1-dia. insulator)

Terminal Arrangement

(1)	⊕	Brown
(2)	L	Pink
(3)	OUT	Black
(4)	⊖	Blue

Connector Hold-down Clip

EE-1006A

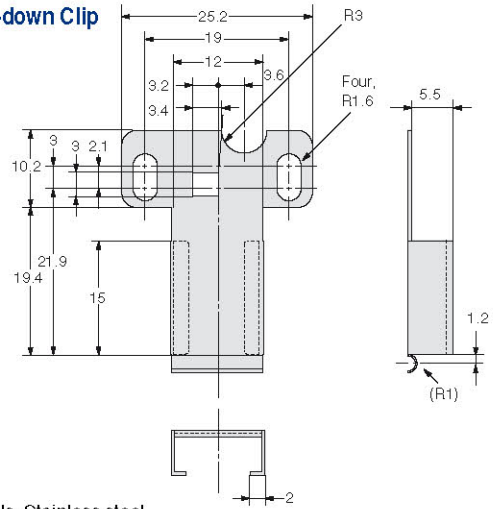
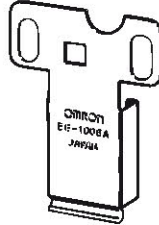

Materials: Stainless steel

Connector with Cable

EE-1010

Connector with Robot Cable

EE-1010-R

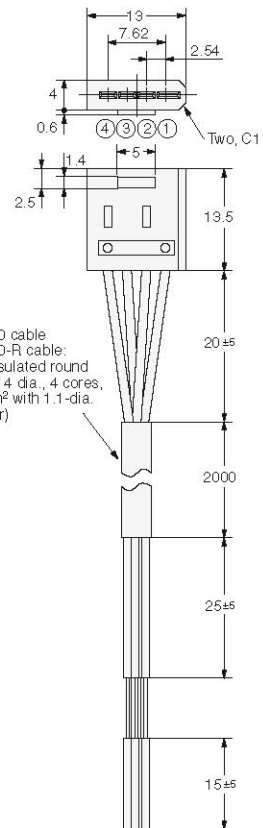
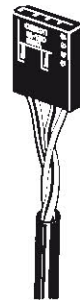

EE-1010 cable
EE-1010-R cable:
Vinyl-insulated round cable of 4 dia., 4 cores, (0.2 mm² with 1.1-dia. insulator)

Connector

EE-1009

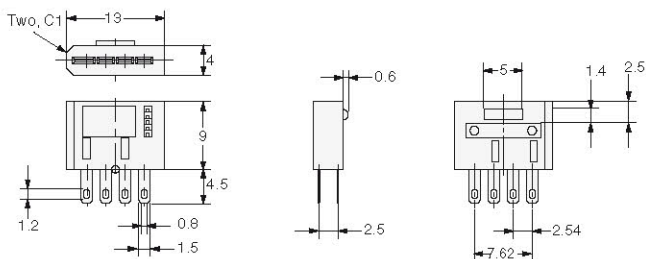

Terminal Arrangement

(1)	⊕	Brown
(2)	L	Pink
(3)	OUT	Black
(4)	⊖	Blue

In the interest of product improvement, specifications are subject to change without notice.

X-ON Electronics

Largest Supplier of Electrical and Electronic Components

Click to view similar products for [Photoelectric Sensors](#) category:

Click to view products by [Omron](#) manufacturer:

Other Similar products are found below :

[E3JM-DS70R4T-US](#) [E3L2DC4](#) [E3RA-DN12 2M](#) [E3RA-DP12 2M](#) [E3S5LE4S](#) [E3S-AD38](#) [E3S-CR11 5M](#) [E3SCT11D5M](#) [E3SCT11M1J03M](#)
[E3T-CT22S](#) [E3T-FD12R](#) [E3T-SL14R](#) [E3T-SL24 5M](#) [E3T-ST12R](#) [E3T-ST24 2M](#) [E3X-CN02](#) [E3X-CN11 5M](#) [E3X-CN21 10M](#) [E3ZM-B66](#)
[E3ZM-CL81H 2M](#) [E3Z-T62 2M](#) [NJL5303R-TE1](#) [PB10CNT15PO](#) [PD60CNX20BP](#) [FZS](#) [CX-491-P-J](#) [CX-491-Z](#) [XUM2BKCNL2T](#)
[XUM2BKCNL2T](#) [XUM2BNANL2R](#) [Y92E-ES30M](#) [Y92E-GS08SS](#) [ZXTDS04T](#) [ZX-XC4A 4M](#) [E3E23Y2US](#) [E3JM-DS70S4-US](#) [E3RA-](#)
[RN11 2M](#) [E3S5LE42M](#) [E3S-LS20XB4 5M](#) [E3S-LS3PW 2M](#) [E3TFD14N](#) [E3T-FD14R](#) [E3T-SL21 5M](#) [E3T-SL21M](#) [E3T-ST11R](#) [E3T-ST12](#)
[5M](#) [E3X-DA41-S-M1J 0.3M](#) [E3X-DAB6](#) [E3X-DAG8](#) [E3ZM-B86](#)