

Features

- Eight Darlington transistors with common emitters
- Output current to 500 mA
- Output voltage to 50 V
- Integral suppression diodes
- Versions for all popular logic families
- Output can be paralleled
- Inputs pinned opposite outputs to simplify board layout

Description

The ULN2801A, ULN2802A, ULN2803A and ULN2804A each contain eight Darlington transistors with common emitters and integral suppression diodes for inductive loads. Each Darlington features a peak load current rating of 600 mA (500 mA continuous) and can withstand at least 50 V in the OFF state. Outputs may be paralleled for higher current capability.

Four versions are available to simplify interfacing to standard logic families: the ULN2801A is designed for general purpose applications with a current limit resistor; the ULN2802A has a 10.5 k Ω input resistor and Zener for 14-25 V PMOS; the ULN2803A has a 2.7 k Ω input resistor for 5 V TTL and CMOS; the ULN2804A has a 10.5 k Ω input resistor for 6-15 V CMOS.

All types are supplied in an 18-lead plastic DIP with a copper lead form and feature the convenient input-opposite-output pinout to simplify board layout.

Table 1. Device summary

Order codes	Package
ULN2801A	DIP-18
ULN2802A	
ULN2803A	
ULN2804A	

Contents

1	Diagram	3
2	Pin configuration	4
3	Maximum ratings	5
4	Electrical characteristics	6
5	Test circuits	7
6	Typical performance characteristics	9
7	Package mechanical data	11
8	Revision history	13

2 Pin configuration

Figure 2. Pin connections (top view)

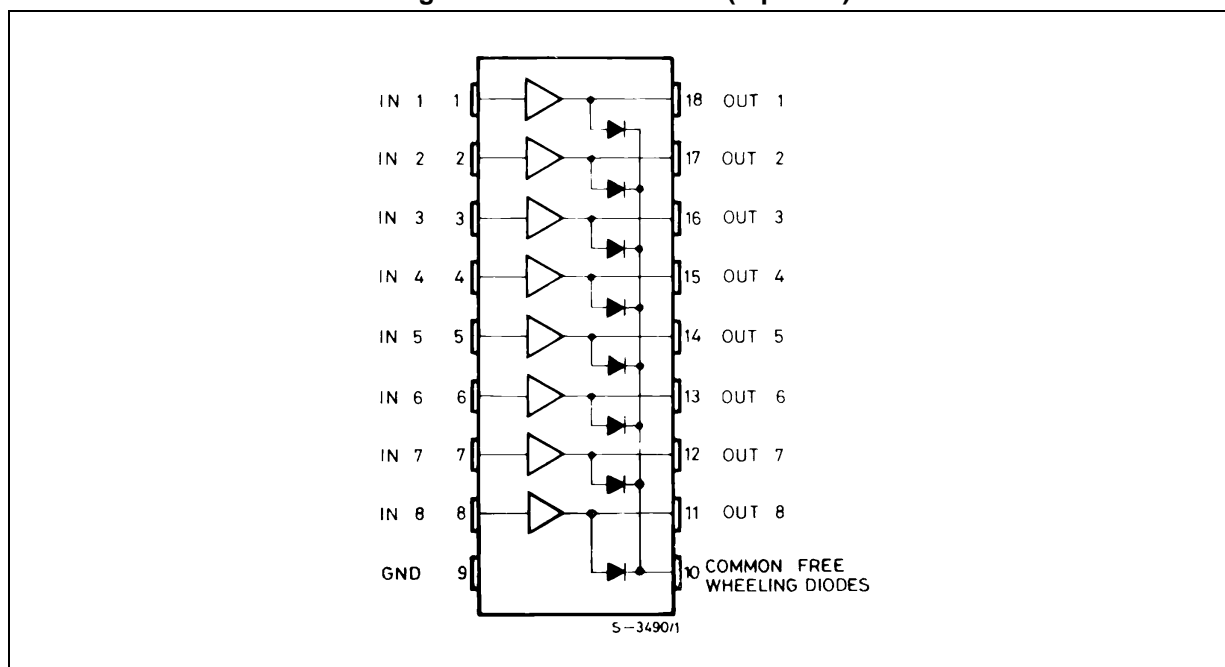

3 Maximum ratings

Table 2. Absolute maximum ratings

Symbol	Parameter	Value	Unit
V_O	Output voltage	50	V
V_I	Input voltage (for ULN2802A - ULN2803A - ULN2804A)	30	V
I_C	Continuous collector current	500	mA
I_B	Continuous base current	25	mA
P_{TOT}	Power Dissipation (one Darlington pair)	1	W
	Power Dissipation (total package)	2.25	
T_A	Operating ambient temperature range	- 20 to 85	°C
T_{STG}	Storage temperature range	- 55 to 150	°C
T_J	Junction temperature	-20 to 150	°C

Table 3. Thermal data

Symbol	Parameter	Value	Unit
R_{thJA}	Thermal resistance junction-ambient	55	°C/W

4 Electrical characteristics

$T_A = 25\text{ °C}$ unless otherwise specified.

Table 4. Electrical characteristics

Symbol	Parameter	Test condition	Min.	Typ.	Max.	Unit
I_{CEX}	Output leakage current	$V_{CE} = 50\text{ V}$				μA
		$T_A = 70\text{ °C}$, $V_{CE} = 50\text{ V}$ (Figure 3)			50	
		$T_A = 70\text{ °C}$ for ULN2802A, $V_{CE} = 50\text{ V}$, $V_I = 6\text{ V}$ (Figure 4)			100	
		$T_A = 70\text{ °C}$ for ULN2804A, $V_{CE} = 50\text{ V}$, $V_I = 1\text{ V}$ (Figure 4)			500	
$V_{CE(SAT)}$	Collector-emitter saturation voltage (Figure 5)	$I_C = 100\text{ mA}$, $I_B = 250\text{ }\mu\text{A}$		0.9	1.1	V
		$I_C = 200\text{ mA}$, $I_B = 350\text{ }\mu\text{A}$		1.1	1.3	
		$I_C = 350\text{ mA}$, $I_B = 500\text{ }\mu\text{A}$		1.3	1.6	
$I_{I(ON)}$	Input current (Figure 6)	for ULN2802A, $V_I = 17\text{ V}$		0.82	1.25	mA
		for ULN2803A, $V_I = 3.85\text{ V}$		0.93	1.35	
		for ULN2804A, $V_I = 5\text{ V}$		0.35	0.5	
		$V_I = 12\text{ V}$		1	1.45	
$I_{I(OFF)}$	Input current (Figure 7)	$T_A = 70\text{ °C}$, $I_C = 500\text{ }\mu\text{A}$	50	65		μA
$V_{I(ON)}$	Input voltage (Figure 8)	$V_{CE} = 2\text{ V}$, for ULN2802A			13	V
		$I_C = 300\text{ mA}$			2.4	
		for ULN2803A			2.7	
		$I_C = 200\text{ mA}$			3	
		$I_C = 250\text{ mA}$			5	
		for ULN2804A			6	
		$I_C = 125\text{ mA}$			7	
		$I_C = 200\text{ mA}$			8	
$I_C = 275\text{ mA}$						
$I_C = 350\text{ mA}$						
h_{FE}	DC Forward current gain (Figure 5)	for ULN2801A, $V_{CE} = 2\text{ V}$, $I_C = 350\text{ mA}$	1000			
C_I	Input capacitance			15	25	pF
t_{PLH}	Turn-on delay time	$0.5 V_I$ to $0.5V_O$		0.25	1	μs
t_{PHL}	Turn-off delay time	$0.5 V_I$ to $0.5V_O$		0.25	1	μs
I_R	Clamp diode leakage current (Figure 9)	$V_R = 50\text{ V}$			50	μA
		$T_A = 70\text{ °C}$, $V_R = 50\text{ V}$			100	
V_F	Clamp diode forward voltage (Figure 10)	$I_F = 350\text{ mA}$		1.7	2	V

5 Test circuits

Figure 3. Output leakage current

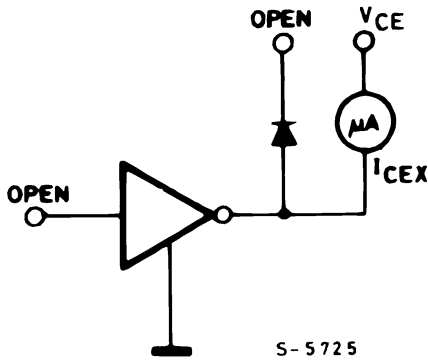

Figure 4. Output leakage current (for ULN2802A only)

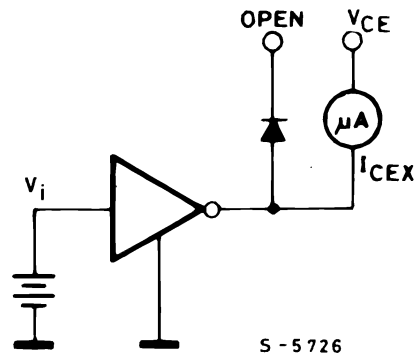

Figure 5. Collector-emitter saturation voltage

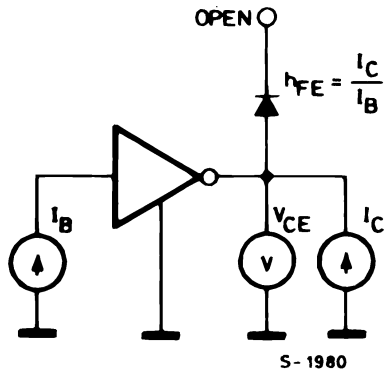

Figure 6. Input current (ON)

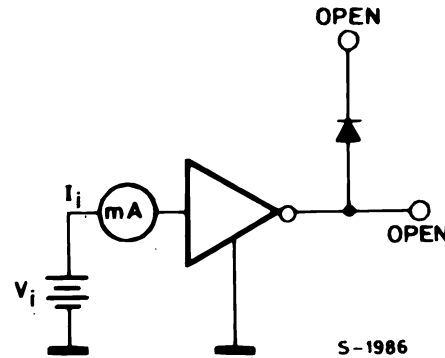

Figure 7. Input current (OFF)

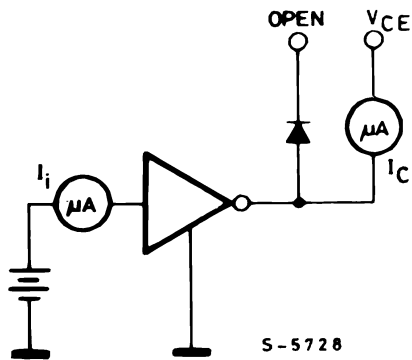
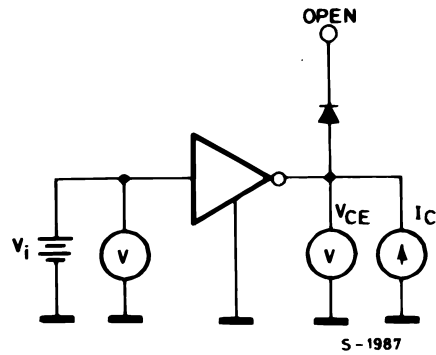
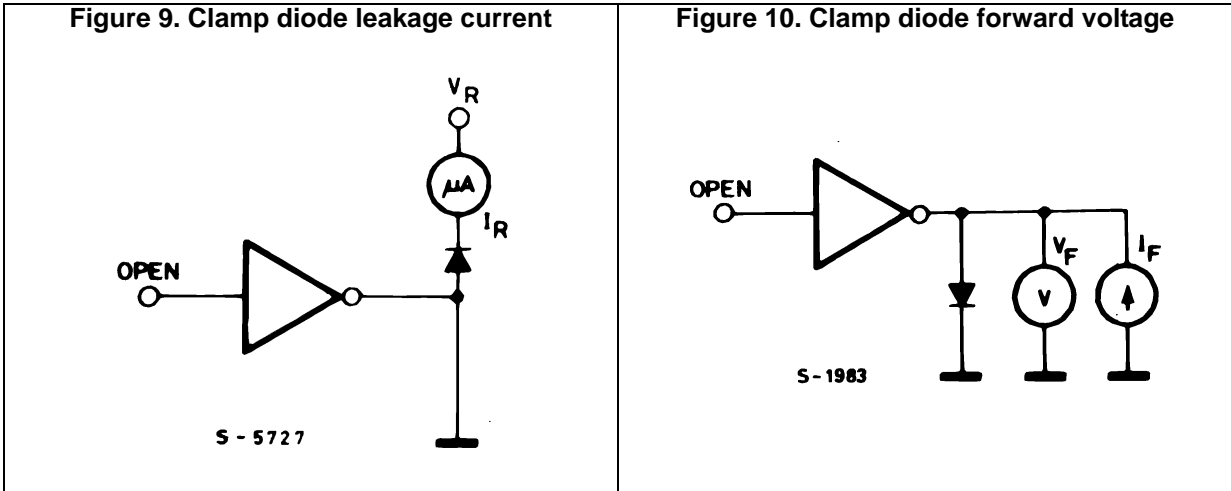

Figure 8. Input voltage





6 Typical performance characteristics

Figure 11. Collector current as a function of saturation voltage

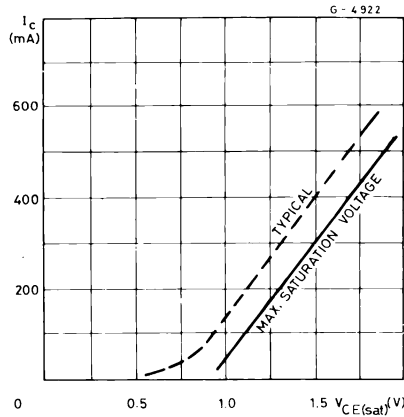

Figure 12. Collector current as a function of input current

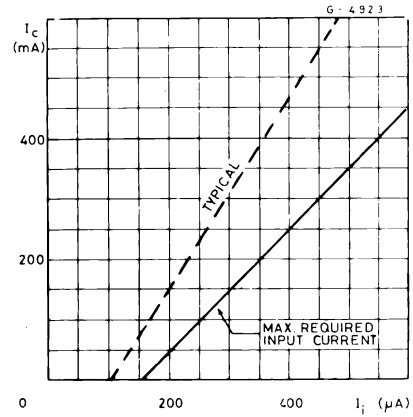

Figure 13. Allowable average power dissipation as a function of T_A

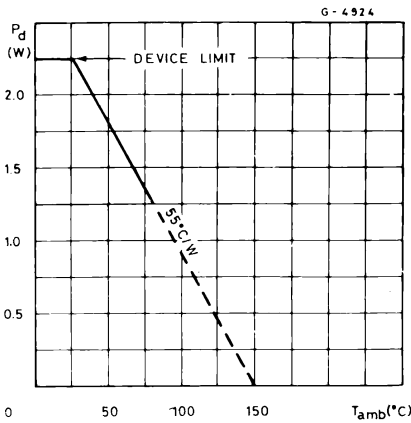

Figure 14. Peak collector current as a function of duty cycle

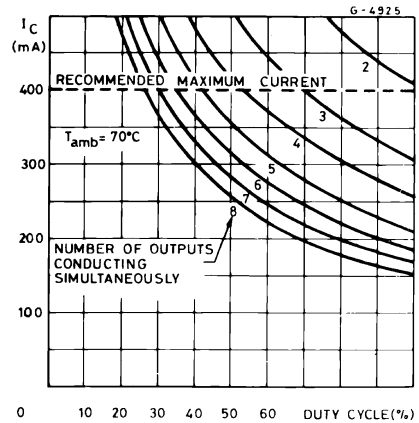

Figure 15. Peak collector current as a function of duty cycle

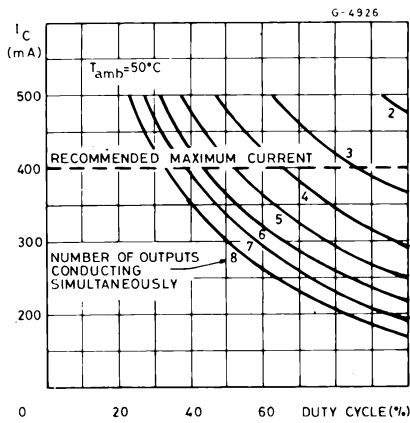

Figure 16. Input current as a function of input voltage (for ULN2802A)

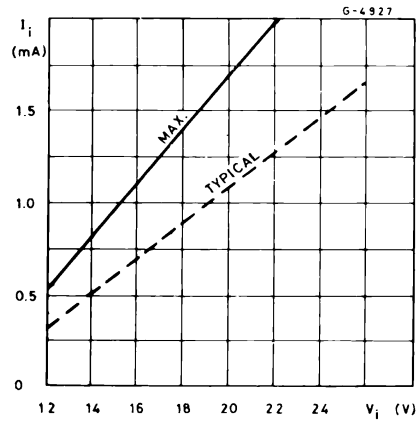

Figure 17. Input current as a function of input voltage (for ULN2804A)

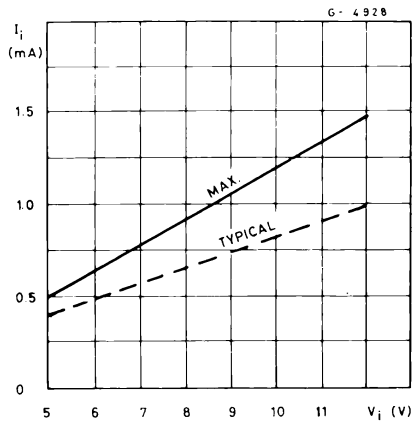
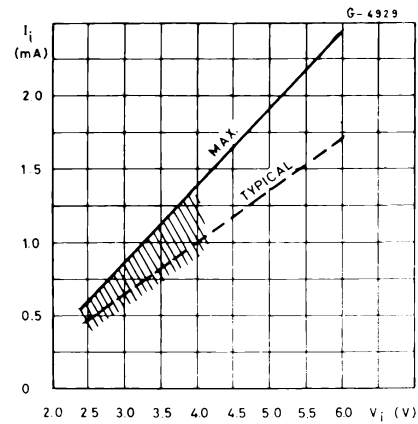

Figure 18. Input current as a function of input voltage (for ULN2803A)



7 Package mechanical data

In order to meet environmental requirements, ST offers these devices in different grades of ECOPACK[®] packages, depending on their level of environmental compliance. ECOPACK[®] specifications, grade definitions and product status are available at: www.st.com. ECOPACK[®] is an ST trademark.

Table 5. DIP-18 mechanical data

Dim.	mm.		
	Min.	Typ.	Max.
a1	0.254		
B	1.39		1.65
b		0.46	
b1		0.25	
D			23.24
E		8.5	
e		2.54	
e3		20.32	
F			7.1
I			3.93
L		3.3	
Z		1.27	1.59

Figure 19. DIP-18 package dimensions

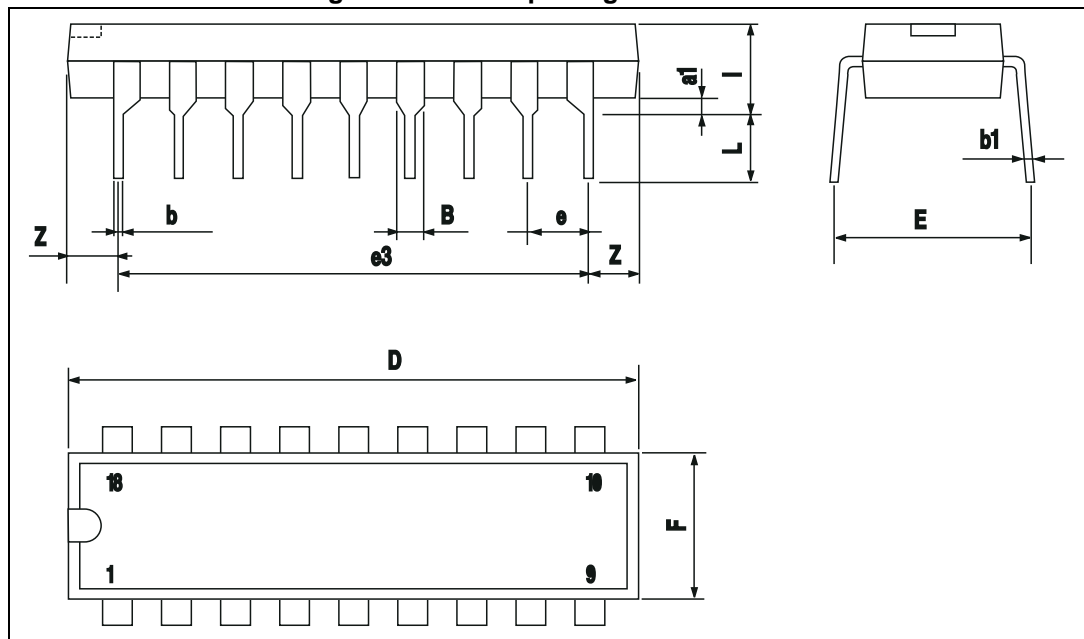

8 Revision history

Table 6. Document revision history

Date	Revision	Changes
18-Sep-2003	1	First release
10-Mar-2010	2	Updated package mechanical data
19-Nov-2012	3	Modified input voltage values Table 4 on page 6.
27-Jun-2018	4	Updated: $I_{I(ON)}$ test condition in Table 4: Electrical characteristics .

IMPORTANT NOTICE – PLEASE READ CAREFULLY

STMicroelectronics NV and its subsidiaries ("ST") reserve the right to make changes, corrections, enhancements, modifications, and improvements to ST products and/or to this document at any time without notice. Purchasers should obtain the latest relevant information on ST products before placing orders. ST products are sold pursuant to ST's terms and conditions of sale in place at the time of order acknowledgement.

Purchasers are solely responsible for the choice, selection, and use of ST products and ST assumes no liability for application assistance or the design of Purchasers' products.

No license, express or implied, to any intellectual property right is granted by ST herein.

Resale of ST products with provisions different from the information set forth herein shall void any warranty granted by ST for such product.

ST and the ST logo are trademarks of ST. All other product or service names are the property of their respective owners.

Information in this document supersedes and replaces information previously supplied in any prior versions of this document.

© 2018 STMicroelectronics – All rights reserved

X-ON Electronics

Largest Supplier of Electrical and Electronic Components

Click to view similar products for [Darlington Transistors](#) category:

Click to view products by [STMicroelectronics](#) manufacturer:

Other Similar products are found below :

[281287X](#) [SMMBT6427LT1G](#) [2N7371](#) [BDV64B](#) [JANTXV2N6287](#) [028710A](#) [SMMBTA64LT1G](#) [2N6350](#) [2SB1214-TL-E](#)
[SMMBTA14LT1G](#) [SBSP52T1G](#) [NJVMJD117T4G](#) [Jantx2N6058](#) [2N6353](#) [LB1205-L-E](#) [500-00005](#) [2N6053](#) [NJVMJD112G](#) [Jan2N6350](#)
[Jantx2N6352](#) [Jantx2N6350](#) [BULN2803LVS](#) [ULN2001N](#) [2SB1383](#) [2SB1560](#) [2SB852KT146B](#) [TIP112TU](#) [TIP122TU](#) [BCV27](#) [MMBTA13-](#)
[TP](#) [MMBTA14-TP](#) [MMSTA28T146](#) [BSP50H6327XTSA1](#) [KSH122TF](#) [NTE2557](#) [NJVNJD35N04T4G](#) [TIP115](#) [MPSA29-D26Z](#) [MJD127T4](#)
[FJB102TM](#) [BCV26E6327HTSA1](#) [BCV46E6327HTSA1](#) [BCV47E6327HTSA1](#) [BSP61H6327XTSA1](#) [BU941ZPFI](#) [2SB1316TL](#) [2SD1980TL](#)
[NTE2350](#) [NTE245](#) [NTE246](#)