

3000 Series Thermostats in Vehicle Fire Suppression Applications

BACKGROUND

A fire resulting from a vehicle collision may lead to death because it becomes impossible to escape the burning vehicle. An effective fire suppression system helps to reduce fatalities in these situations.

SOLUTION

Honeywell manufactures the 3000 Series Thermostats (see Table 1), a range of rugged, sealed thermostats, that signal when a certain temperature has been reached. In an automatic fire suppression system, the thermostat signals the system to discharge in the event of a fire.

When the thermostat ambient temperature reaches the rated temperature, the switch contacts close, completing the electrical circuit which triggers the system actuator. When the thermostat cools, the contacts reopen, which resets the thermostat to its normal operation condition.

At least one thermostat is installed in each protected area of the vehicle (see Figure 1). The four-conductor configuration allows continuous integrity monitoring of all circuits connecting the thermostats.

Table 1. 3000 Series Vehicle Fire Suppression Thermostat

3000 Series Vehicle Fire Suppression Thermostat

Features and Benefits
<ul style="list-style-type: none"> • Stainless steel housing provides enhanced resistance to corrosion and harsh, under-the-hood chemicals • Sealed construction designed to prevent water ingress • Configurable operating point may be tailored to application requirements up to 232 °C [450 °F] • Enhanced response for reduced deployment time • Enhanced reliability for potentially maintenance-free operation • Flexible mounting bracket allows multiple installation sites for the same product

Figure 1. Fire Suppression System Block Diagram

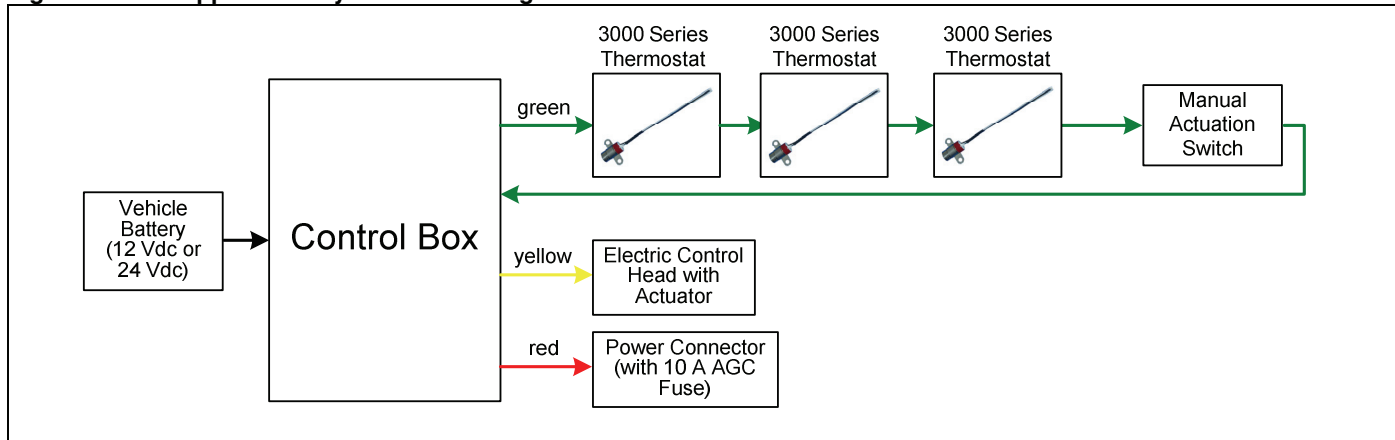

3000 Series in Vehicle Fire Suppression Applications

WARNING

PERSONAL INJURY

DO NOT USE these products as safety or emergency stop devices or in any other application where failure of the product could result in personal injury.

Failure to comply with these instructions could result in death or serious injury.

WARRANTY/REMEDY

Honeywell warrants goods of its manufacture as being free of defective materials and faulty workmanship. Honeywell's standard product warranty applies unless agreed to otherwise by Honeywell in writing; please refer to your order acknowledgement or consult your local sales office for specific warranty details. If warranted goods are returned to Honeywell during the period of coverage, Honeywell will repair or replace, at its option, without charge those items it finds defective. The foregoing is buyer's sole remedy and is in lieu of all other warranties, expressed or implied, including those of merchantability and fitness for a particular purpose. In no event shall Honeywell be liable for consequential, special, or indirect damages.

While we provide application assistance personally, through our literature and the Honeywell web site, it is up to the customer to determine the suitability of the product in the application.

Specifications may change without notice. The information we supply is believed to be accurate and reliable as of this printing. However, we assume no responsibility for its use.

WARNING

MISUSE OF DOCUMENTATION

- The information presented in this application note is for reference only. Do not use this document as a product installation guide.
- Complete installation, operation, and maintenance information is provided in the instructions supplied with each product.

Failure to comply with these instructions could result in death or serious injury.

SALES AND SERVICE

Honeywell serves its customers through a worldwide network of sales offices, representatives and distributors. For application assistance, current specifications, pricing or name of the nearest Authorized Distributor, contact your local sales office or:

E-mail: info.sc@honeywell.com

Internet: www.honeywell.com/sensing

Phone and Fax:

Asia Pacific	+65 6355-2828 +65 6445-3033 Fax
Europe	+44 (0) 1698 481481 +44 (0) 1698 481676 Fax
Latin America	+1-305-805-8188 +1-305-883-8257 Fax
USA/Canada	+1-800-537-6945 +1-815-235-6847 +1-815-235-6545 Fax

Sensing and Control
Honeywell
1985 Douglas Drive North
Golden Valley, MN 55422
www.honeywell.com/sensing

008096-1-EN IL50 GLO Printed in USA
March 2009
Copyright © 2009 Honeywell International Inc. All rights reserved.

Honeywell

X-ON Electronics

Largest Supplier of Electrical and Electronic Components

Click to view similar products for [honeywell](#) manufacturer:

Other Similar products are found below :

[MML93J](#) [3010A](#) [5VP1](#) [5VP2](#) [LZJ3-7M](#) [V7-2B27E9](#) [LTPCTAA50UEBITX01](#) [MPRLS0001PG0000SAB](#) [LZZ7J3-7M](#) [76072-00000150-15](#)
[NSCDRRN030PDUNV](#) [5SM3-TN196](#) [NSCDRRN001PGUNV](#) [14CE2-2](#) [91MCE2-S5](#) [SE3450-013](#) [GLLA06A1B](#) [3600080010001](#) [23944-01](#)
[53C110K](#) [58C1-25](#) [58C1-3K](#) [591SXP56S252SC](#) [5ML1-E1](#) [5SE1-12](#) [602HE1-6](#) [604HE223-6B](#) [61CX11-D01](#) [624HE17-RB](#) [M3050A13](#)
[64AT22-3D](#) [66AT23-7](#) [6AT3-T](#) [6HM7-6](#) [MA215HT-96](#) [6PA104](#) [6PA148-E6](#) [701PB580](#) [70B1N056S202W](#) [727033](#) [EXD-AR20](#)
[MD3211Q16](#) [76054-00000700-01](#) [76061-00000015-15](#) [76061-B00000020-01](#) [76078-00000350-01](#) [76078-B00000400-01](#) [76580-00000130-01](#)
[76584-M00000100-24](#) [F78EA502](#)