

74HC237

3-to-8 line decoder, demultiplexer with address latches

Rev. 6 — 23 August 2012

Product data sheet

1. General description

The 74HC237 is a high-speed Si-gate CMOS device and is pin compatible with low-power Schottky TTL (LSTTL). The 74HC237 is specified in compliance with JEDEC standard no. 7A.

The 74HC237 is a 3-to-8 line decoder, demultiplexer with latches at the three address inputs (An). The 74HC237 essentially combines the 3-to-8 decoder function with a 3-bit storage latch. When the latch is enabled ($\overline{LE} = \text{LOW}$), the 74HC237 acts as a 3-to-8 active LOW decoder. When the latch enable (\overline{LE}) goes from LOW-to-HIGH, the last data present at the inputs before this transition, is stored in the latches. Further address changes are ignored as long as \overline{LE} remains HIGH. The output enable input ($\overline{E1}$ and $E2$) controls the state of the outputs independent of the address inputs or latch operation. All outputs are HIGH unless $\overline{E1}$ is LOW and $E2$ is HIGH. The 74HC237 is ideally suited for implementing non-overlapping decoders in 3-state systems and strobed (stored address) applications in bus-oriented systems.

2. Features and benefits

- Combines 3-to-8 decoder with 3-bit latch
- Multiple input enable for easy expansion or independent controls
- Active HIGH mutually exclusive outputs
- Low-power dissipation
- ESD protection:
 - ◆ HBM JESD22-A114F exceeds 2 000 V
 - ◆ MM JESD22-A115-A exceeds 200 V
- Multiple package options
- Specified from $-40\text{ }^{\circ}\text{C}$ to $+85\text{ }^{\circ}\text{C}$ and from $-40\text{ }^{\circ}\text{C}$ to $+125\text{ }^{\circ}\text{C}$

3. Ordering information

Table 1. Ordering information

Type number	Package			
	Temperature range	Name	Description	Version
74HC237N	$-40\text{ }^{\circ}\text{C}$ to $+125\text{ }^{\circ}\text{C}$	DIP16	plastic dual in-line package; 16 leads (300 mil)	SOT38-4
74HC237D	$-40\text{ }^{\circ}\text{C}$ to $+125\text{ }^{\circ}\text{C}$	SO16	plastic small outline package; 16 leads; body width 3.9 mm	SOT109-1
74HC237DB	$-40\text{ }^{\circ}\text{C}$ to $+125\text{ }^{\circ}\text{C}$	SSOP16	plastic shrink small outline package; 16 leads; body width 5.3 mm	SOT338-1



4. Functional diagram

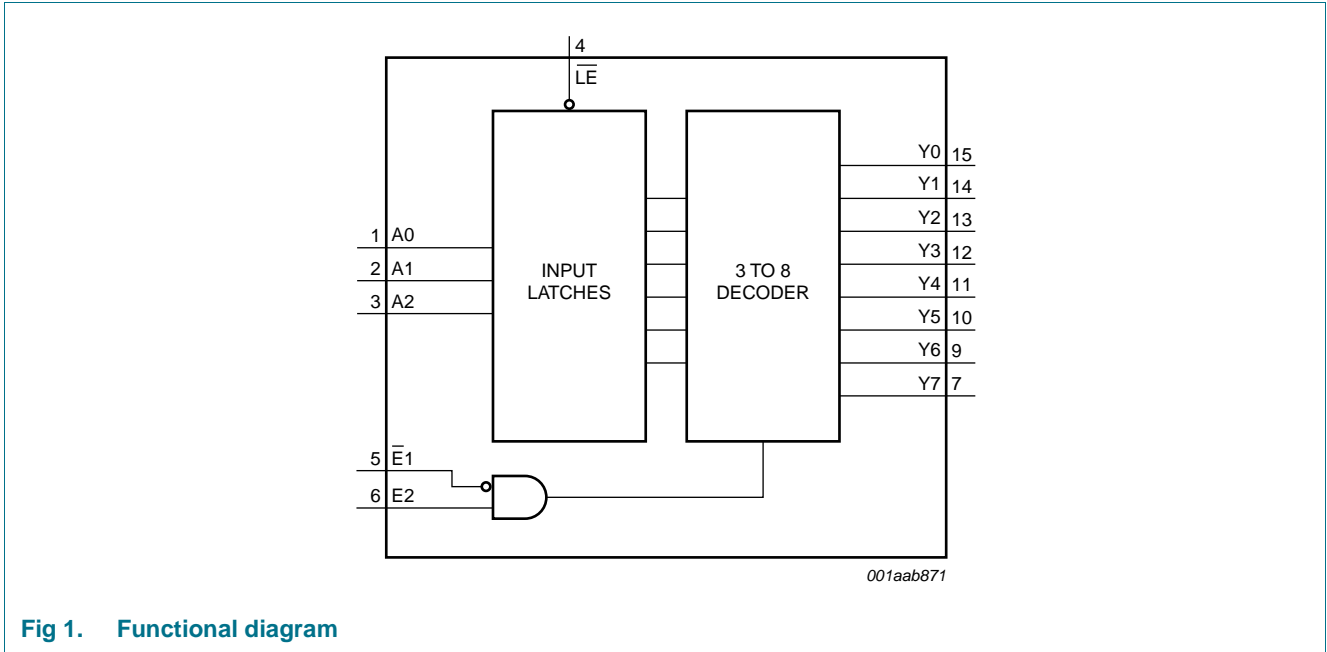

Fig 1. Functional diagram

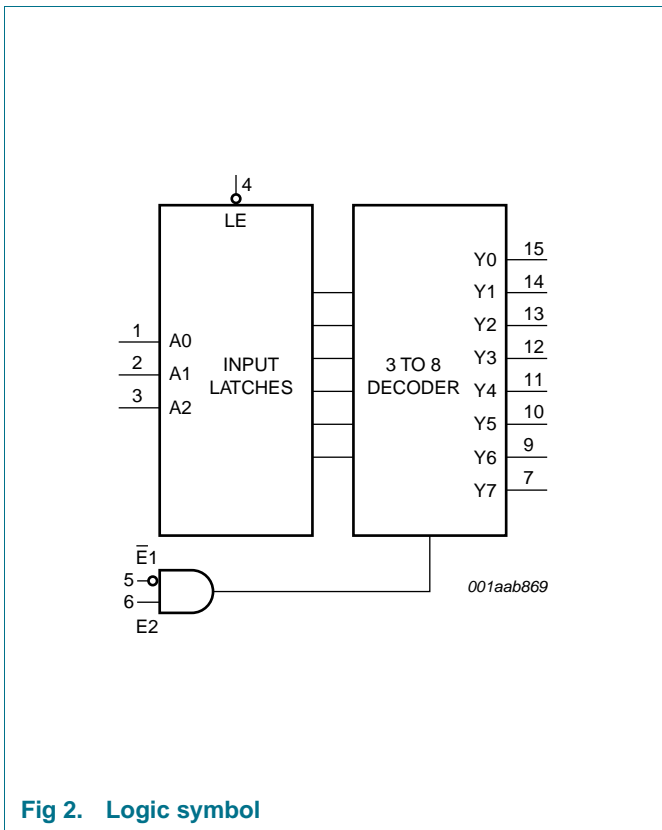

Fig 2. Logic symbol

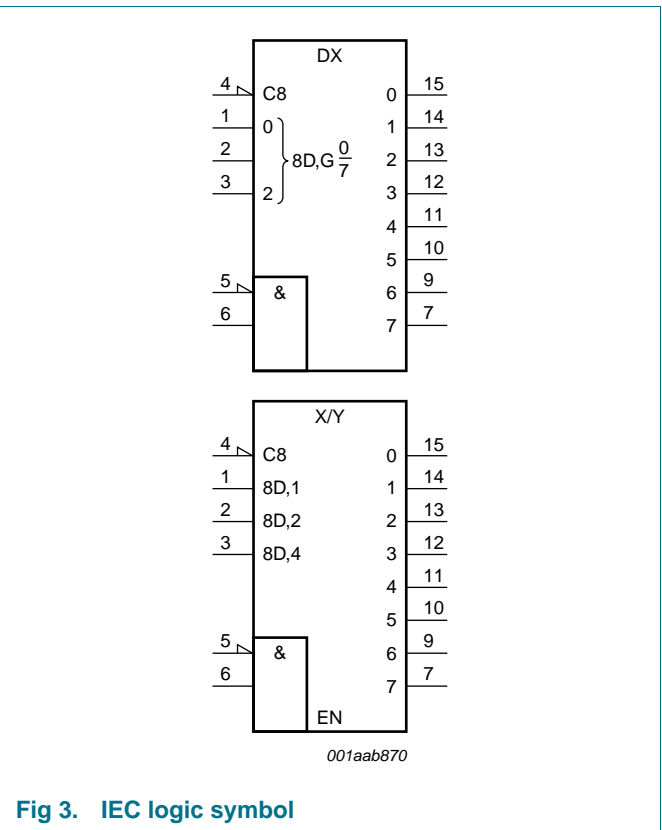

Fig 3. IEC logic symbol

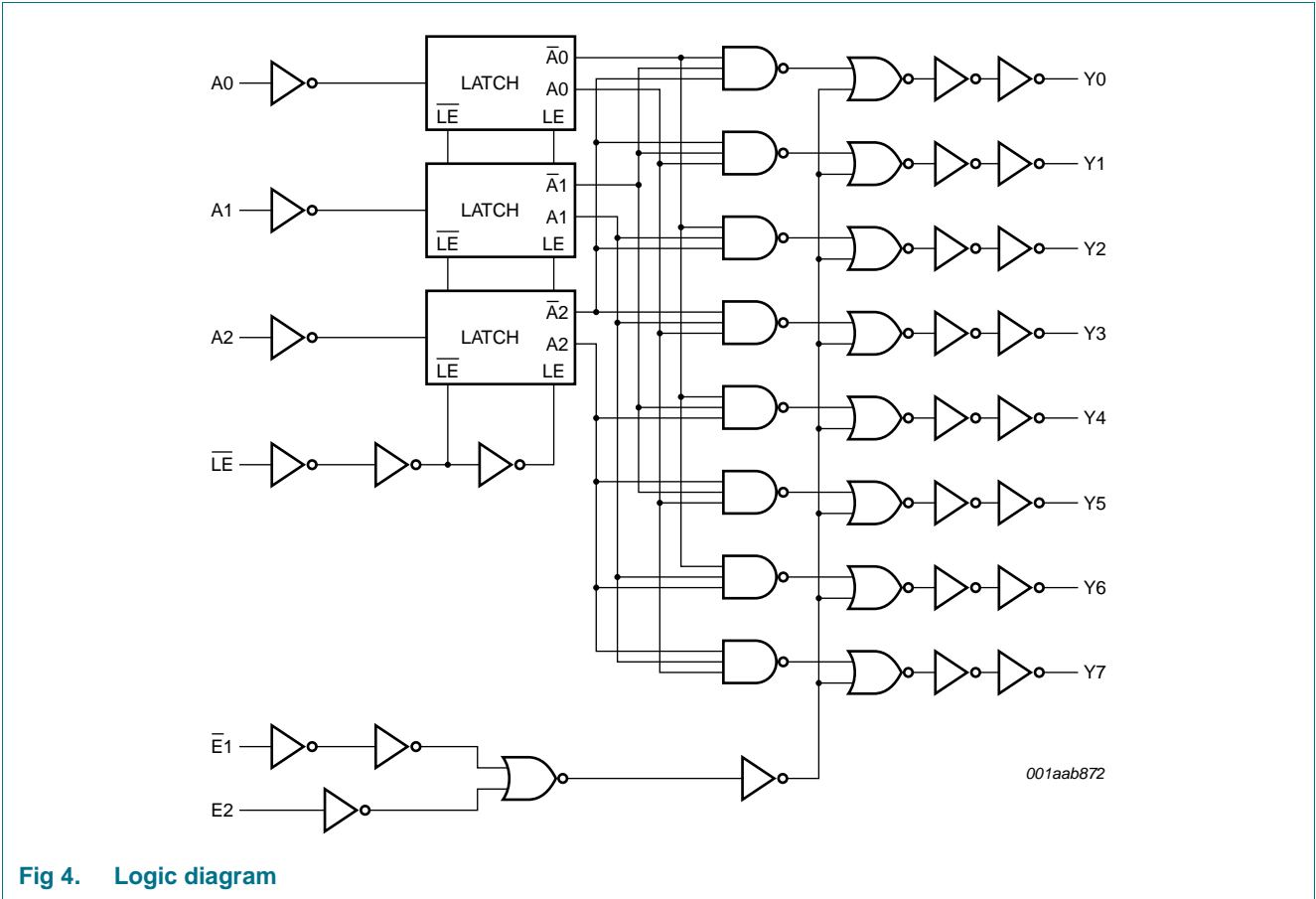

Fig 4. Logic diagram

5. Pinning information

5.1 Pinning

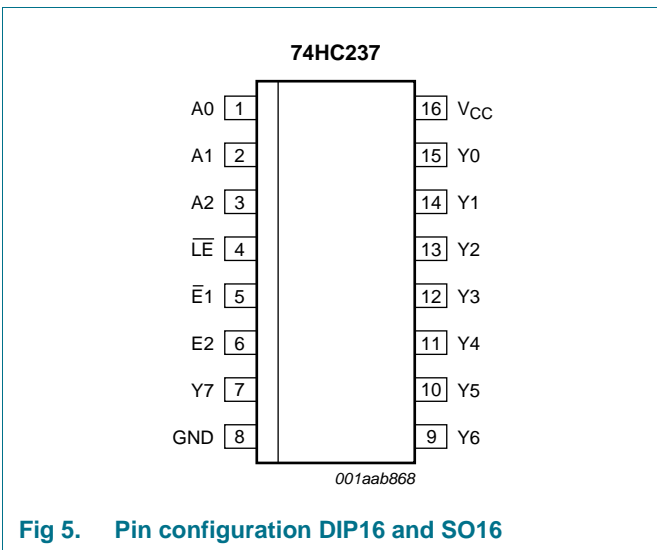

Fig 5. Pin configuration DIP16 and SO16

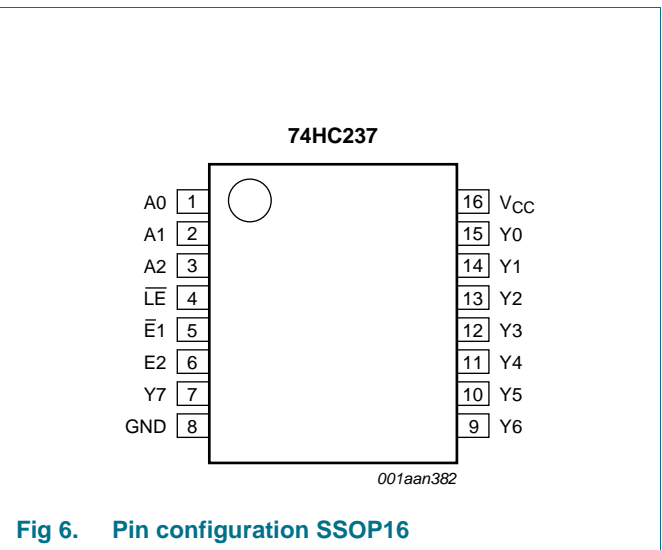

Fig 6. Pin configuration SSOP16

5.2 Pin description

Table 2. Pin description

Symbol	Pin	Description
A0 to A2	1, 2, 3	data input
\overline{LE}	4	latch enable input (active LOW)
$\overline{E1}$	5	data enable input 1 (active LOW)
E2	6	data enable input 2 (active HIGH)
Y0 to Y7	15, 14, 13, 12, 11, 10, 9, 7	output
GND	8	ground (0 V)
V _{CC}	16	supply voltage

6. Functional description

Table 3: Function table

Enable			Input			Output							
\overline{LE}	$\overline{E1}$	E2	A0	A1	A2	Y0	Y1	Y2	Y3	Y4	Y5	Y6	Y7
H	L	H	X	X	X	stable							
X	H	X	X	X	X	L	L	L	L	L	L	L	L
X	X	L	X	X	X	L	L	L	L	L	L	L	L
L	L	H	L	L	L	H	L	L	L	L	L	L	L
			H	L	L	L	H	L	L	L	L	L	L
			L	H	L	L	L	H	L	L	L	L	L
			H	H	L	L	L	L	H	L	L	L	L
			L	L	H	L	L	L	L	H	L	L	L
			H	L	H	L	L	L	L	L	H	L	L
			L	H	H	L	L	L	L	L	L	H	L
			H	H	H	L	L	L	L	L	L	L	L

[1] H = HIGH voltage level; L = LOW voltage level; X = don't care; Z = high-impedance OFF-state.

7. Limiting values

Table 4. Limiting values

In accordance with the Absolute Maximum Rating System (IEC 60134). Voltages are referenced to GND (ground = 0 V).

Symbol	Parameter	Conditions	Min	Max	Unit	
V _{CC}	supply voltage		-0.5	+7	V	
I _{IK}	input clamping current	V _I < -0.5 V or V _I > V _{CC} + 0.5 V	-	±20	mA	
I _{OK}	output clamping current	V _O < -0.5 V or V _O > V _{CC} + 0.5 V	-	±20	mA	
I _O	output current	V _O = -0.5 V to (V _{CC} + 0.5 V)	-	±25	mA	
I _{CC}	supply current		-	+50	mA	
I _{GND}	ground current		-	-50	mA	
T _{stg}	storage temperature		-65	+150	°C	
P _{tot}	total power dissipation	DIP16 package	[1]	-	750	mW
		SO16 and SSOP16 packages	[2]	-	500	mW

- [1] For DIP16 package: P_{tot} derates linearly with 12 mW/K above 70 °C.
- [2] For SO16 package: P_{tot} derates linearly with 8 mW/K above 70 °C.
For SSOP16 package: P_{tot} derates linearly with 5.5 mW/K above 60 °C.

8. Recommended operating conditions

Table 5. Recommended operating conditions

Voltages are referenced to GND (ground = 0 V)

Symbol	Parameter	Conditions	Min	Typ	Max	Unit
V_{CC}	supply voltage		2.0	5.0	6.0	V
V_I	input voltage		0	-	V_{CC}	V
V_O	output voltage		0	-	V_{CC}	V
T_{amb}	ambient temperature		-40	+25	+125	°C
$\Delta t/\Delta V$	input transition rise and fall rate	$V_{CC} = 2.0\text{ V}$	-	-	625	ns/V
		$V_{CC} = 4.5\text{ V}$	-	1.67	139	ns/V
		$V_{CC} = 6.0\text{ V}$	-	-	83	ns/V

9. Static characteristics

Table 6. Static characteristics

At recommended operating conditions; voltages are referenced to GND (ground = 0 V).

Symbol	Parameter	Conditions	$T_{amb} = 25\text{ °C}$			$T_{amb} = -40\text{ °C to }+85\text{ °C}$		$T_{amb} = -40\text{ °C to }+125\text{ °C}$		Unit
			Min	Typ	Max	Min	Max	Min	Max	
V_{IH}	HIGH-level input voltage	$V_{CC} = 2.0\text{ V}$	1.5	1.2	-	1.5	-	1.5	-	V
		$V_{CC} = 4.5\text{ V}$	3.15	2.4	-	3.15	-	3.15	-	V
		$V_{CC} = 6.0\text{ V}$	4.2	3.2	-	4.2	-	4.2	-	V
V_{IL}	LOW-level input voltage	$V_{CC} = 2.0\text{ V}$	-	0.8	0.5	-	0.5	-	0.5	V
		$V_{CC} = 4.5\text{ V}$	-	2.1	1.35	-	1.35	-	1.35	V
		$V_{CC} = 6.0\text{ V}$	-	2.8	1.8	-	1.8	-	1.8	V
V_{OH}	HIGH-level output voltage	$V_I = V_{IH}$ or V_{IL}								
		$I_O = -20\text{ }\mu\text{A}; V_{CC} = 2.0\text{ V}$	1.9	2.0	-	1.9	-	1.9	-	V
		$I_O = -20\text{ }\mu\text{A}; V_{CC} = 4.5\text{ V}$	4.4	4.5	-	4.4	-	4.4	-	V
		$I_O = -20\text{ }\mu\text{A}; V_{CC} = 6.0\text{ V}$	5.9	6.0	-	5.9	-	5.9	-	V
		$I_O = -4.0\text{ mA}; V_{CC} = 4.5\text{ V}$	3.98	4.32	-	3.84	-	3.7	-	V
		$I_O = -5.2\text{ mA}; V_{CC} = 6.0\text{ V}$	5.48	5.81	-	5.34	-	5.2	-	V
V_{OL}	LOW-level output voltage	$V_I = V_{IH}$ or V_{IL}								
		$I_O = 20\text{ }\mu\text{A}; V_{CC} = 2.0\text{ V}$	-	0	0.1	-	0.1	-	0.1	V
		$I_O = 20\text{ }\mu\text{A}; V_{CC} = 4.5\text{ V}$	-	0	0.1	-	0.1	-	0.1	V
		$I_O = 20\text{ }\mu\text{A}; V_{CC} = 6.0\text{ V}$	-	0	0.1	-	0.1	-	0.1	V
		$I_O = 4.0\text{ mA}; V_{CC} = 4.5\text{ V}$	-	0.15	0.26	-	0.33	-	0.4	V
		$I_O = 5.2\text{ mA}; V_{CC} = 6.0\text{ V}$	-	0.16	0.26	-	0.33	-	0.4	V

Table 6. Static characteristics ...continued

At recommended operating conditions; voltages are referenced to GND (ground = 0 V).

Symbol	Parameter	Conditions	T _{amb} = 25 °C			T _{amb} = -40 °C to +85 °C		T _{amb} = -40 °C to +125 °C		Unit
			Min	Typ	Max	Min	Max	Min	Max	
I _I	input leakage current	V _I = V _{CC} or GND; V _{CC} = 6.0 V	-	-	±0.1	-	±1.0	-	±1.0	μA
I _{CC}	supply current	V _I = V _{CC} or GND; I _O = 0 A; V _{CC} = 6.0 V	-	-	8.0	-	80	-	160	μA
C _I	input capacitance		-	3.5	-	-	-	-	-	pF

10. Dynamic characteristics

Table 7. Dynamic characteristicsVoltages are referenced to GND (ground = 0 V); C_L = 50 pF unless otherwise specified; for test circuit see [Figure 10](#).

Symbol	Parameter	Conditions	T _{amb} = 25 °C			T _{amb} = -40 °C to +85 °C		T _{amb} = -40 °C to +125 °C		Unit
			Min	Typ	Max	Min	Max	Min	Max	
t _{pd}	propagation delay	An to Y _n ; see Figure 7 ^[1]								
		V _{CC} = 2.0 V	-	52	160	-	200	-	240	ns
		V _{CC} = 4.5 V	-	19	32	-	40	-	48	ns
		V _{CC} = 5 V; C _L = 15 pF	-	16	-	-	-	-	-	ns
		V _{CC} = 6.0 V	-	15	27	-	34	-	41	ns
		\overline{LE} to Y _n ; see Figure 7 ^[1]								
		V _{CC} = 2.0 V	-	61	190	-	240	-	285	ns
		V _{CC} = 4.5 V	-	22	38	-	48	-	57	ns
		V _{CC} = 5 V; C _L = 15 pF	-	19	-	-	-	-	-	ns
		V _{CC} = 6.0 V	-	18	32	-	41	-	48	ns
		$\overline{E1}$ to Y _n ; see Figure 8 ^[1]								
		V _{CC} = 2.0 V	-	47	145	-	180	-	220	ns
		V _{CC} = 4.5 V	-	17	29	-	36	-	44	ns
		V _{CC} = 5 V; C _L = 15 pF	-	14	-	-	-	-	-	ns
		V _{CC} = 6.0 V	-	14	25	-	31	-	38	ns
		t _t	transition time	E2 to Y _n ; see Figure 7 ^[1]						
V _{CC} = 2.0 V	-			47	145	-	180	-	220	ns
V _{CC} = 4.5 V	-			17	29	-	36	-	44	ns
V _{CC} = 5 V; C _L = 15 pF	-			14	-	-	-	-	-	ns
V _{CC} = 6.0 V	-			14	25	-	31	-	38	ns
Y _n ; see Figure 7 and Figure 8 ^[2]										
V _{CC} = 2.0 V	-			19	75	-	95	-	110	ns
V _{CC} = 4.5 V	-			7	15	-	19	-	22	ns
V _{CC} = 6.0 V	-	6	13	-	16	-	19	ns		

Table 7. Dynamic characteristics ...continued

Voltages are referenced to GND (ground = 0 V); $C_L = 50$ pF unless otherwise specified; for test circuit see [Figure 10](#).

Symbol	Parameter	Conditions	$T_{amb} = 25\text{ }^\circ\text{C}$			$T_{amb} = -40\text{ }^\circ\text{C}$ to $+85\text{ }^\circ\text{C}$		$T_{amb} = -40\text{ }^\circ\text{C}$ to $+125\text{ }^\circ\text{C}$		Unit
			Min	Typ	Max	Min	Max	Min	Max	
t_W	pulse width	\overline{LE} HIGH; see Figure 9								
		$V_{CC} = 2.0\text{ V}$	50	11	-	65	-	75	-	ns
		$V_{CC} = 4.5\text{ V}$	10	4	-	13	-	15	-	ns
		$V_{CC} = 6.0\text{ V}$	9	3	-	11	-	13	-	ns
t_{su}	set-up time	An to \overline{LE} ; see Figure 9								
		$V_{CC} = 2.0\text{ V}$	50	6	-	65	-	75	-	ns
		$V_{CC} = 4.5\text{ V}$	10	2	-	13	-	15	-	ns
		$V_{CC} = 6.0\text{ V}$	9	2	-	11	-	13	-	ns
t_h	hold time	An to \overline{LE} ; see Figure 9								
		$V_{CC} = 2.0\text{ V}$	30	3	-	40	-	45	-	ns
		$V_{CC} = 4.5\text{ V}$	6	1	-	8	-	9	-	ns
		$V_{CC} = 6.0\text{ V}$	5	1	-	7	-	8	-	ns
C_{PD}	power dissipation capacitance	$C_L = 50\text{ pF}$; $f = 1\text{ MHz}$; $V_1 = \text{GND to } V_{CC}$	[3]	-	60	-	-	-	-	pF

- [1] t_{pd} is the same as t_{PLH} and t_{PHL} .
- [2] t_t is the same as t_{THL} and t_{TLH} .
- [3] C_{PD} is used to determine the dynamic power dissipation (P_D in μW).
 $P_D = C_{PD} \times V_{CC}^2 \times f_i \times N + \sum(C_L \times V_{CC}^2 \times f_o)$ where:
 f_i = input frequency in MHz;
 f_o = output frequency in MHz;
 C_L = output load capacitance in pF;
 V_{CC} = supply voltage in V;
 N = number of inputs switching;
 $\sum(C_L \times V_{CC}^2 \times f_o)$ = sum of outputs.

11. Waveforms

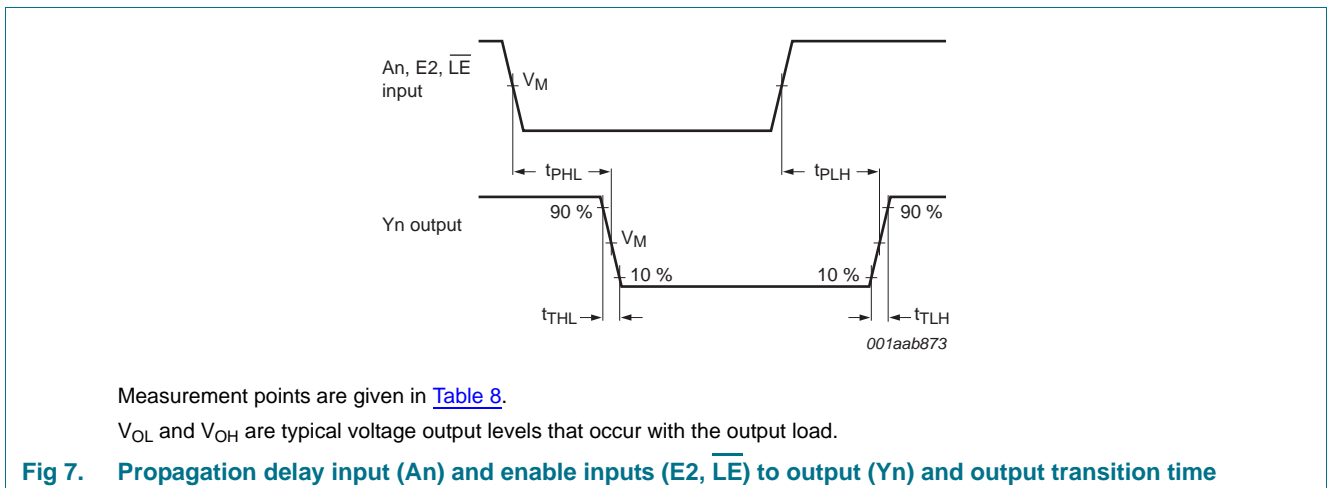

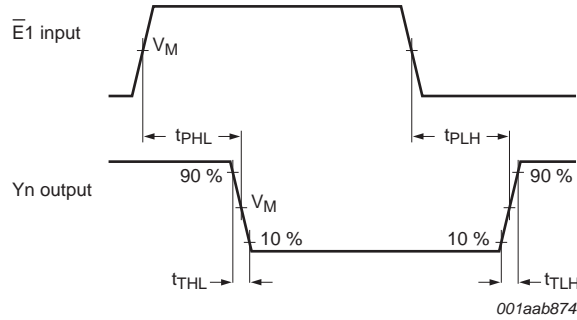

Measurement points are given in [Table 8](#).

V_{OL} and V_{OH} are typical voltage output levels that occur with the output load.

Fig 8. Propagation enable inputs ($\bar{E}1$) to output (Y_n) and output transition time

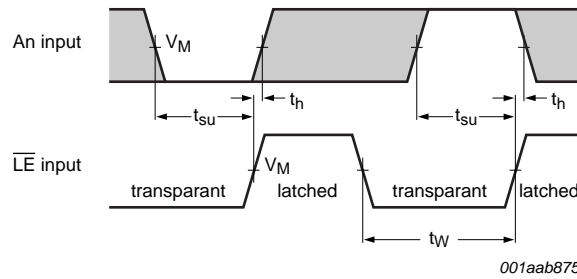

Measurement points are given in [Table 8](#).

V_{OL} and V_{OH} are typical voltage output levels that occur with the output load.

Fig 9. The data input (A_n) to latch enable input (\bar{LE}) set-up times, latch enable input (\bar{LE}) to data input (A_n) hold times and latch enable input (\bar{LE}) pulse width

Table 8. Measurement points

Type	Input	Output
	V_M	V_M
74HC237	$0.5V_{CC}$	$0.5V_{CC}$

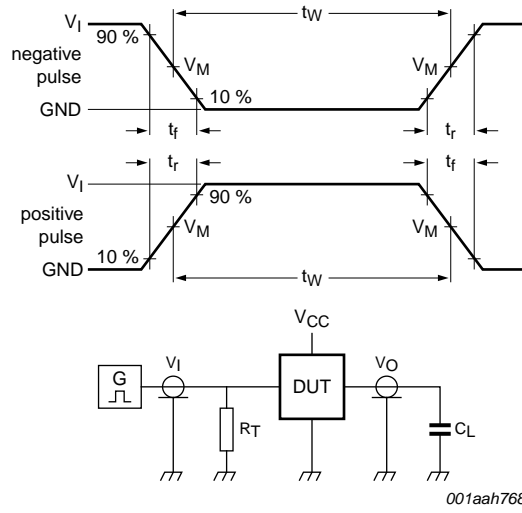

Test data is given in [Table 9](#).

Definitions test circuit:

R_T = Termination resistance should be equal to output impedance Z_o of the pulse generator.

C_L = Load capacitance including jig and probe capacitance.

R_L = Load resistance.

S1 = Test selection switch.

Fig 10. Test circuit for measuring switching times

Table 9. Test data

Type	Input		Load	Test
	V_I	t_r, t_f	C_L	
74HC237	V_{CC}	6.0 ns	15 pF, 50 pF	t_{PLH}, t_{PHL}

12. Application information

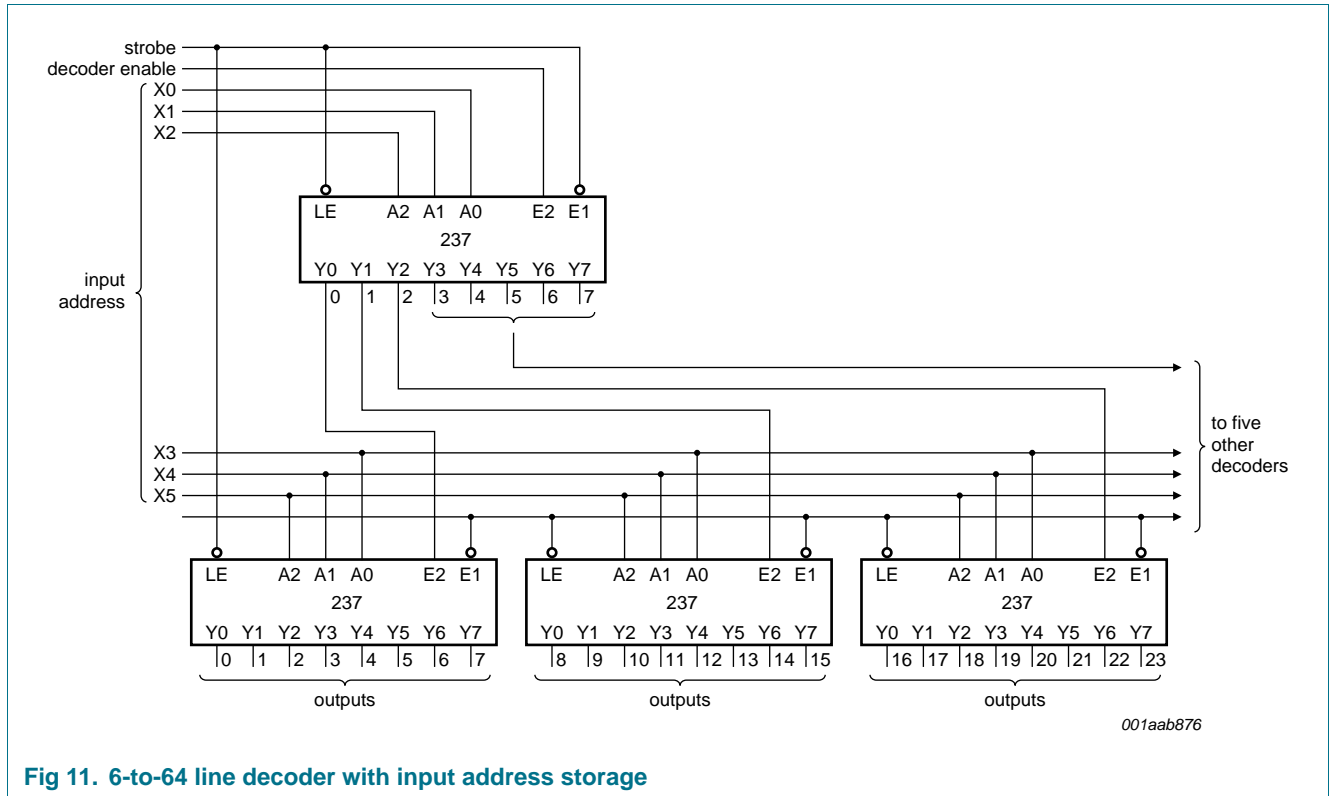

Fig 11. 6-to-64 line decoder with input address storage

13. Package outline

DIP16: plastic dual in-line package; 16 leads (300 mil)

SOT38-4

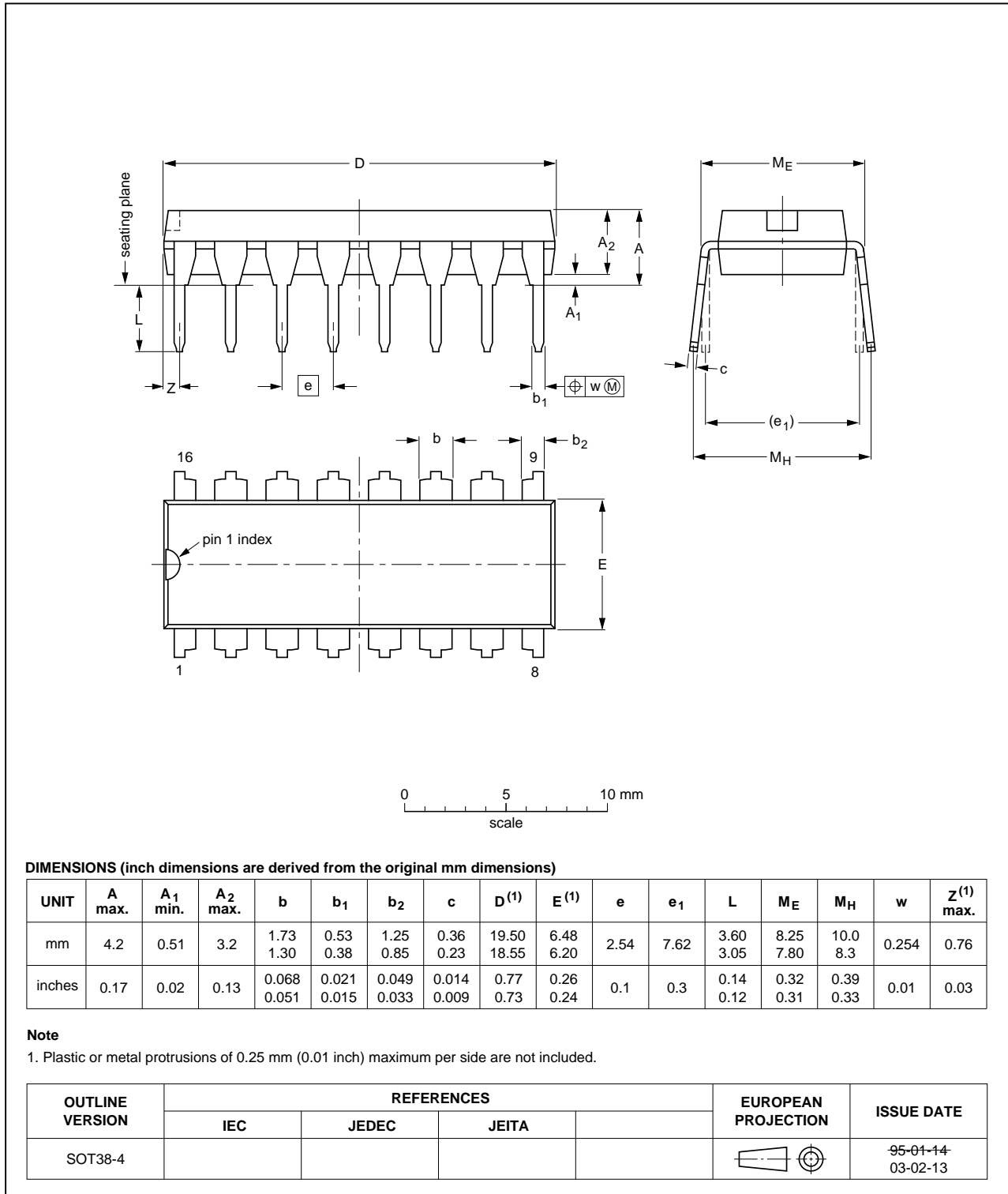

Fig 12. Package outline SOT38-4 (DIP16)

SO16: plastic small outline package; 16 leads; body width 3.9 mm

SOT109-1

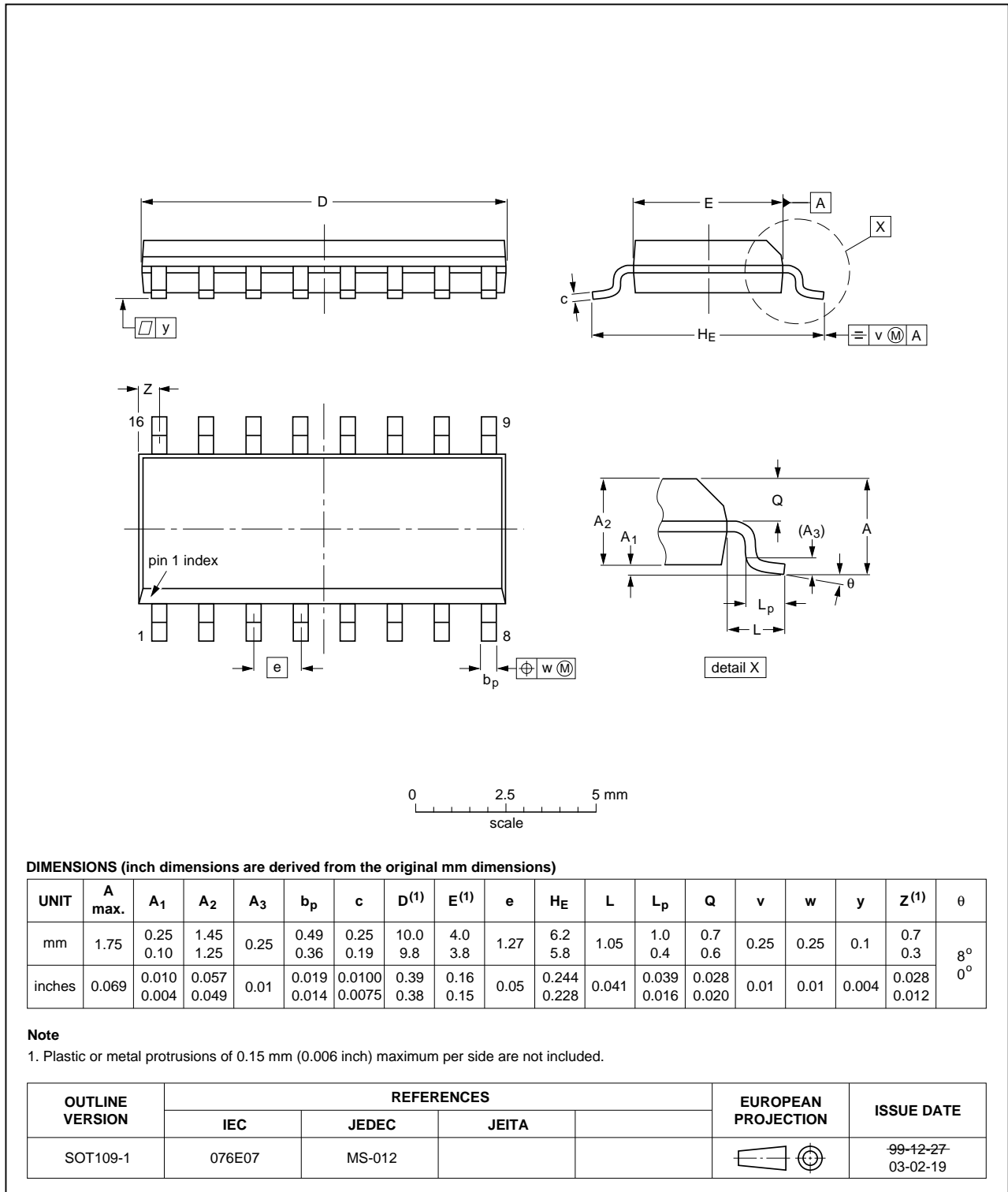

Fig 13. Package outline SOT109-1 (SO16)

SSOP16: plastic shrink small outline package; 16 leads; body width 5.3 mm

SOT338-1

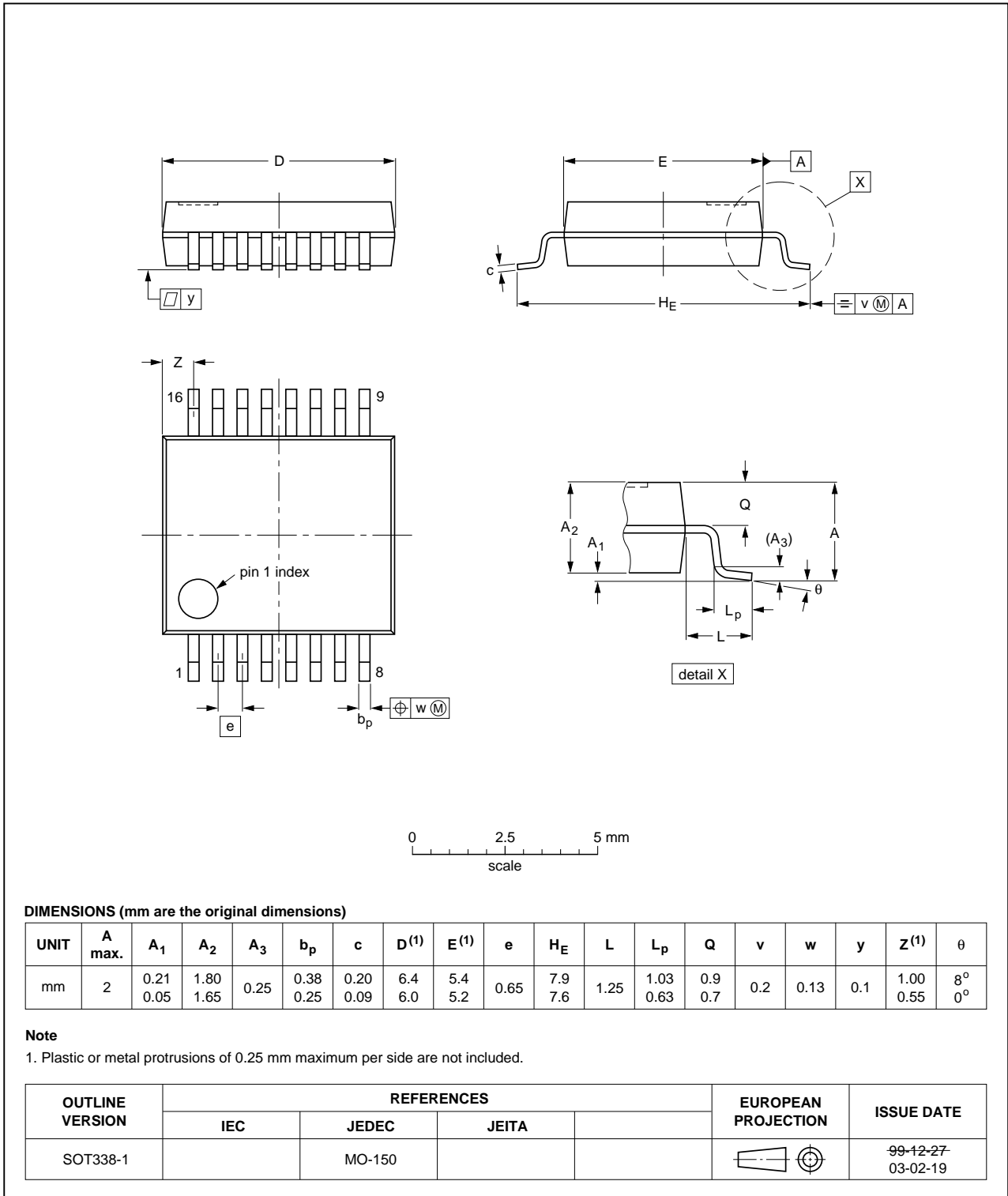

Fig 14. Package outline SOT338-1 (SSOP16)

14. Abbreviations

Table 10. Abbreviations

Acronym	Description
CMOS	Complementary Metal Oxide Semiconductor
DUT	Device Under Test
ESD	ElectroStatic Discharge
HBM	Human Body Model
MM	Machine Model
TTL	Transistor-Transistor Logic

15. Revision history

Table 11. Revision history

Document ID	Release date	Data sheet status	Change notice	Supersedes
74HC237 v.6	20120823	Product data sheet	-	74HC237 v.5
Modifications:	<ul style="list-style-type: none"> Measurement points added to Figure 7 and Figure 8 (errata). 			
74HC237 v.5	20111209	Product data sheet	-	74HC237 v.4
Modifications:	<ul style="list-style-type: none"> Legal pages updated. 			
74HC237 v.4	20110110	Product data sheet	-	74HC237 v.3
74HC237 v.3	20041112	Product data sheet	-	74HC_HCT237_CNV v.2
74HC_HCT237_CNV v.2	19970828	Product specification	-	74HC_HCT237 v.1
74HC_HCT237 v.1	19901201	Product specification	-	-

16. Legal information

16.1 Data sheet status

Document status ^{[1][2]}	Product status ^[3]	Definition
Objective [short] data sheet	Development	This document contains data from the objective specification for product development.
Preliminary [short] data sheet	Qualification	This document contains data from the preliminary specification.
Product [short] data sheet	Production	This document contains the product specification.

[1] Please consult the most recently issued document before initiating or completing a design.

[2] The term 'short data sheet' is explained in section "Definitions".

[3] The product status of device(s) described in this document may have changed since this document was published and may differ in case of multiple devices. The latest product status information is available on the Internet at URL <http://www.nxp.com>.

16.2 Definitions

Draft — The document is a draft version only. The content is still under internal review and subject to formal approval, which may result in modifications or additions. NXP Semiconductors does not give any representations or warranties as to the accuracy or completeness of information included herein and shall have no liability for the consequences of use of such information.

Short data sheet — A short data sheet is an extract from a full data sheet with the same product type number(s) and title. A short data sheet is intended for quick reference only and should not be relied upon to contain detailed and full information. For detailed and full information see the relevant full data sheet, which is available on request via the local NXP Semiconductors sales office. In case of any inconsistency or conflict with the short data sheet, the full data sheet shall prevail.

Product specification — The information and data provided in a Product data sheet shall define the specification of the product as agreed between NXP Semiconductors and its customer, unless NXP Semiconductors and customer have explicitly agreed otherwise in writing. In no event however, shall an agreement be valid in which the NXP Semiconductors product is deemed to offer functions and qualities beyond those described in the Product data sheet.

16.3 Disclaimers

Limited warranty and liability — Information in this document is believed to be accurate and reliable. However, NXP Semiconductors does not give any representations or warranties, expressed or implied, as to the accuracy or completeness of such information and shall have no liability for the consequences of use of such information. NXP Semiconductors takes no responsibility for the content in this document if provided by an information source outside of NXP Semiconductors.

In no event shall NXP Semiconductors be liable for any indirect, incidental, punitive, special or consequential damages (including - without limitation - lost profits, lost savings, business interruption, costs related to the removal or replacement of any products or rework charges) whether or not such damages are based on tort (including negligence), warranty, breach of contract or any other legal theory.

Notwithstanding any damages that customer might incur for any reason whatsoever, NXP Semiconductors' aggregate and cumulative liability towards customer for the products described herein shall be limited in accordance with the *Terms and conditions of commercial sale* of NXP Semiconductors.

Right to make changes — NXP Semiconductors reserves the right to make changes to information published in this document, including without limitation specifications and product descriptions, at any time and without notice. This document supersedes and replaces all information supplied prior to the publication hereof.

Suitability for use — NXP Semiconductors products are not designed, authorized or warranted to be suitable for use in life support, life-critical or safety-critical systems or equipment, nor in applications where failure or malfunction of an NXP Semiconductors product can reasonably be expected to result in personal injury, death or severe property or environmental damage. NXP Semiconductors and its suppliers accept no liability for inclusion and/or use of NXP Semiconductors products in such equipment or applications and therefore such inclusion and/or use is at the customer's own risk.

Applications — Applications that are described herein for any of these products are for illustrative purposes only. NXP Semiconductors makes no representation or warranty that such applications will be suitable for the specified use without further testing or modification.

Customers are responsible for the design and operation of their applications and products using NXP Semiconductors products, and NXP Semiconductors accepts no liability for any assistance with applications or customer product design. It is customer's sole responsibility to determine whether the NXP Semiconductors product is suitable and fit for the customer's applications and products planned, as well as for the planned application and use of customer's third party customer(s). Customers should provide appropriate design and operating safeguards to minimize the risks associated with their applications and products.

NXP Semiconductors does not accept any liability related to any default, damage, costs or problem which is based on any weakness or default in the customer's applications or products, or the application or use by customer's third party customer(s). Customer is responsible for doing all necessary testing for the customer's applications and products using NXP Semiconductors products in order to avoid a default of the applications and the products or of the application or use by customer's third party customer(s). NXP does not accept any liability in this respect.

Limiting values — Stress above one or more limiting values (as defined in the Absolute Maximum Ratings System of IEC 60134) will cause permanent damage to the device. Limiting values are stress ratings only and (proper) operation of the device at these or any other conditions above those given in the Recommended operating conditions section (if present) or the Characteristics sections of this document is not warranted. Constant or repeated exposure to limiting values will permanently and irreversibly affect the quality and reliability of the device.

Terms and conditions of commercial sale — NXP Semiconductors products are sold subject to the general terms and conditions of commercial sale, as published at <http://www.nxp.com/profile/terms>, unless otherwise agreed in a valid written individual agreement. In case an individual agreement is concluded only the terms and conditions of the respective agreement shall apply. NXP Semiconductors hereby expressly objects to applying the customer's general terms and conditions with regard to the purchase of NXP Semiconductors products by customer.

No offer to sell or license — Nothing in this document may be interpreted or construed as an offer to sell products that is open for acceptance or the grant, conveyance or implication of any license under any copyrights, patents or other industrial or intellectual property rights.

Export control — This document as well as the item(s) described herein may be subject to export control regulations. Export might require a prior authorization from competent authorities.

Non-automotive qualified products — Unless this data sheet expressly states that this specific NXP Semiconductors product is automotive qualified, the product is not suitable for automotive use. It is neither qualified nor tested in accordance with automotive testing or application requirements. NXP Semiconductors accepts no liability for inclusion and/or use of non-automotive qualified products in automotive equipment or applications.

In the event that customer uses the product for design-in and use in automotive applications to automotive specifications and standards, customer (a) shall use the product without NXP Semiconductors' warranty of the product for such automotive applications, use and specifications, and (b) whenever customer uses the product for automotive applications beyond

NXP Semiconductors' specifications such use shall be solely at customer's own risk, and (c) customer fully indemnifies NXP Semiconductors for any liability, damages or failed product claims resulting from customer design and use of the product for automotive applications beyond NXP Semiconductors' standard warranty and NXP Semiconductors' product specifications.

Translations — A non-English (translated) version of a document is for reference only. The English version shall prevail in case of any discrepancy between the translated and English versions.

16.4 Trademarks

Notice: All referenced brands, product names, service names and trademarks are the property of their respective owners.

17. Contact information

For more information, please visit: <http://www.nxp.com>

For sales office addresses, please send an email to: salesaddresses@nxp.com

18. Contents

1	General description	1
2	Features and benefits	1
3	Ordering information	1
4	Functional diagram	2
5	Pinning information	3
5.1	Pinning	3
5.2	Pin description	4
6	Functional description	4
7	Limiting values	4
8	Recommended operating conditions	5
9	Static characteristics	5
10	Dynamic characteristics	6
11	Waveforms	7
12	Application information	10
13	Package outline	11
14	Abbreviations	14
15	Revision history	14
16	Legal information	15
16.1	Data sheet status	15
16.2	Definitions	15
16.3	Disclaimers	15
16.4	Trademarks	16
17	Contact information	16
18	Contents	17

Please be aware that important notices concerning this document and the product(s) described herein, have been included in section 'Legal information'.

© NXP B.V. 2012.

All rights reserved.

For more information, please visit: <http://www.nxp.com>

For sales office addresses, please send an email to: salesaddresses@nxp.com

Date of release: 23 August 2012

Document identifier: 74HC237

X-ON Electronics

Largest Supplier of Electrical and Electronic Components

Click to view similar products for [Encoders, Decoders, Multiplexers & Demultiplexers](#) category:

Click to view products by [NXP](#) manufacturer:

Other Similar products are found below :

[M38510/01406BEA](#) [MC74HC163ADTG](#) [74HC253N](#) [HMC854LC5TR](#) [NLV74VHC1G01DFT1G](#) [NLVHC4851ADTR2G](#)
[NLVHCT4851ADTR2G](#) [PI3B33X257BE](#) [M74HCT4052ADTR2G](#) [M74VHC1GT04DFT3G](#) [TC74AC138P\(F\)](#) [MC74LVX4051MNTWG](#)
[HMC855LC5TR](#) [NLV14028BDR2G](#) [NLV14051BDR2G](#) [NLV74HC238ADTR2G](#) [715428X](#) [COMX-CAR-210](#) [5962-8607001EA](#) [5962-8756601EA](#) [MAX3783UCM+D](#) [PI5C3253QEX](#) [8CA3052APGGI8](#) [TC74HC4051AF\(EL,F\)](#) [TC74VHC138F\(EL,K,F\)](#) [PI3B3251LE](#)
[PI5C3309UEX](#) [PI5C3251QEX](#) [PI3B3251QE](#) [74VHC4052AFT\(BJ\)](#) [PI3PCIE3415AZHEX](#) [NLV74HC4851AMNTWG](#) [MC74LVX257DG](#)
[M74HC151YRM13TR](#) [M74HC151YTTR](#) [PI5USB31213XEAEX](#) [M74HCT4851ADWR2G](#) [XD74LS154](#) [AP4373AW5-7-01](#) [QS3VH251QG8](#)
[QS4A201QG](#) [HCS301T-ISN](#) [HCS500-I/SM](#) [MC74HC151ADTG](#) [TC4066BP\(N,F\)](#) [74ACT11139PWR](#) [HMC728LC3CTR](#) [74VHC238FT\(BJ\)](#)
[74VHC4066AFT\(BJ\)](#) [74VHCT138AFT\(BJ\)](#)