

DATA SHEET



PCF8575

Remote 16-bit I/O expander for
I²C-bus

Product specification
Supersedes data of 1999 Feb 25
File under Integrated Circuits, IC12

1999 Apr 07

Remote 16-bit I/O expander for I²C-bus**PCF8575**

CONTENTS

1	FEATURES
2	GENERAL DESCRIPTION
3	ORDERING INFORMATION
4	BLOCK DIAGRAM
5	PINNING
6	CHARACTERISTICS OF THE I ² C-BUS
6.1	Bit transfer
6.2	START and STOP conditions
6.3	System configuration
6.4	Acknowledge
7	FUNCTIONAL DESCRIPTION
7.1	Quasi-bidirectional I/Os
7.2	Addressing
7.3	Reading from a port (input mode)
7.4	Writing to the port (output mode)
7.5	Interrupt
8	LIMITING VALUES
9	HANDLING
10	CHARACTERISTICS
11	I ² C-BUS TIMING CHARACTERISTICS
12	DEVICE PROTECTION
13	PACKAGE OUTLINE
14	SOLDERING
14.1	Introduction to soldering surface mount packages
14.2	Reflow soldering
14.3	Wave soldering
14.4	Manual soldering
14.5	Suitability of surface mount IC packages for wave and reflow soldering methods
15	DEFINITIONS
16	LIFE SUPPORT APPLICATIONS
17	PURCHASE OF PHILIPS I ² C COMPONENTS

Remote 16-bit I/O expander for I²C-bus

PCF8575

1 FEATURES

- Operating supply voltage 2.5 to 5.5 V
- Low standby current consumption of 10 μ A maximum
- I²C-bus to parallel port expander
- 400 kbits/s FAST I²C-bus
- Open-drain interrupt output
- 16-bit remote I/O port for the I²C-bus
- Compatible with most microcontrollers
- Latched outputs with high current drive capability for directly driving LEDs
- Address by 3 hardware address pins for use of up to 8 devices
- SSOP24 package.



The device consists of a 16-bit quasi-bidirectional port and an I²C-bus interface. The PCF8575 has a low current consumption and includes latched outputs with high current drive capability for directly driving LEDs. It also possesses an interrupt line ($\overline{\text{INT}}$) which can be connected to the interrupt logic of the microcontroller. By sending an interrupt signal on this line, the remote I/O can inform the microcontroller if there is incoming data on its ports without having to communicate via the I²C-bus. This means that the PCF8575 is an I²C-bus slave transmitter/receiver.

2 GENERAL DESCRIPTION

The PCF8575 is a silicon CMOS circuit. It provides general purpose remote I/O expansion for most microcontroller families via the two-line bidirectional bus (I²C-bus).

Every data transmission from the PCF8575 must consist of an even number of bytes, the first byte will be referred to as P07 to P00 and the second byte as P17 to P10. The third will be referred to as P07 to P00 and so on.

3 ORDERING INFORMATION

TYPE NUMBER	PACKAGE		
	NAME	DESCRIPTION	VERSION
PCF8575TS	SSOP24	plastic shrink small outline package; 24 leads; body width 5.3 mm	SOT340-1

Remote 16-bit I/O expander for I²C-bus

PCF8575

4 BLOCK DIAGRAM

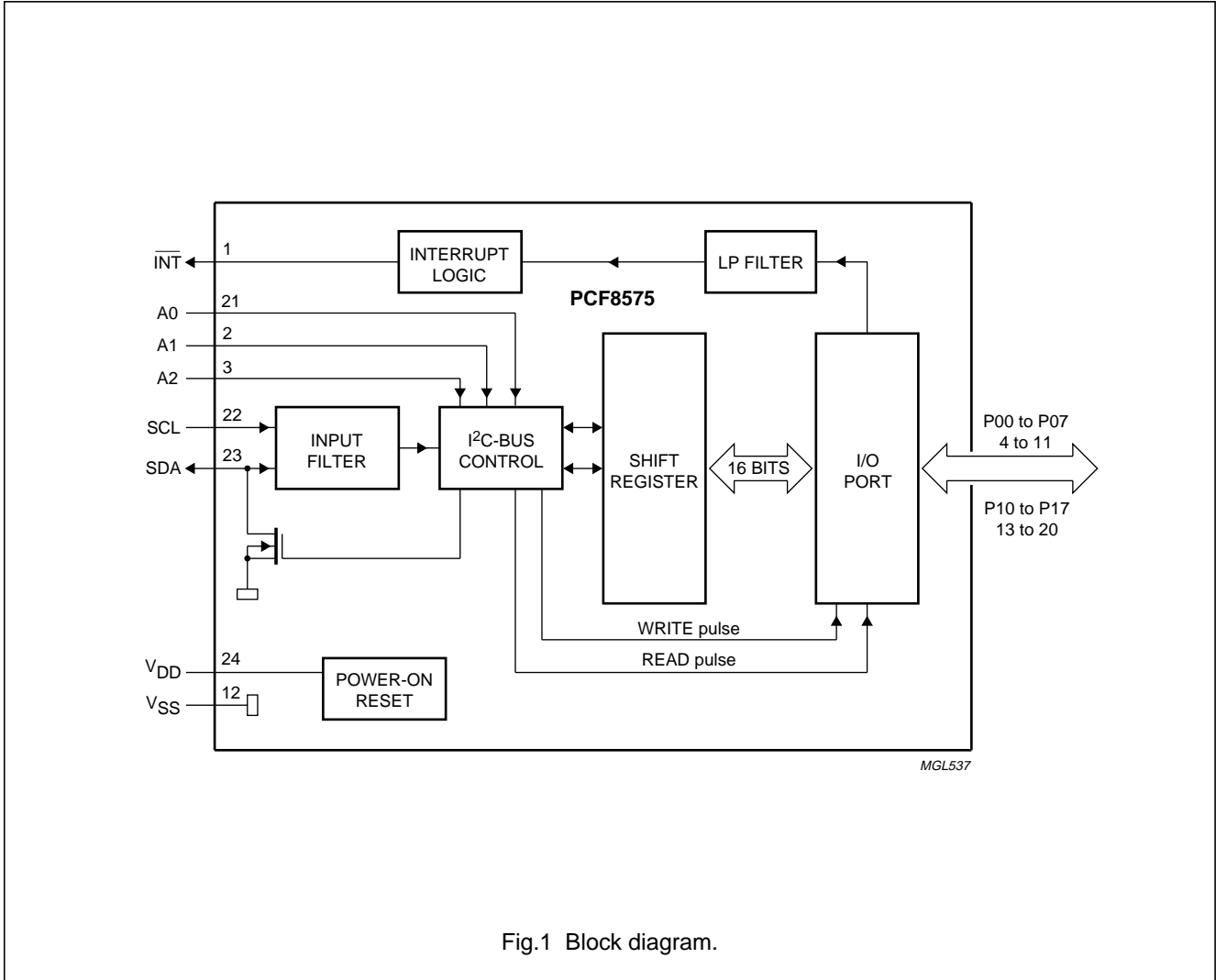

Fig.1 Block diagram.

Remote 16-bit I/O expander for I²C-bus

PCF8575

5 PINNING

SYMBOL	PIN	DESCRIPTION
$\overline{\text{INT}}$	1	interrupt output (active LOW)
A1	2	address input 1
A2	3	address input 2
P00	4	quasi-bidirectional I/O 00
P01	5	quasi-bidirectional I/O 01
P02	6	quasi-bidirectional I/O 02
P03	7	quasi-bidirectional I/O 03
P04	8	quasi-bidirectional I/O 04
P05	9	quasi-bidirectional I/O 05
P06	10	quasi-bidirectional I/O 06
P07	11	quasi-bidirectional I/O 07
V _{SS}	12	supply ground
P10	13	quasi-bidirectional I/O 10
P11	14	quasi-bidirectional I/O 11
P12	15	quasi-bidirectional I/O 12
P13	16	quasi-bidirectional I/O 13
P14	17	quasi-bidirectional I/O 14
P15	18	quasi-bidirectional I/O 15
P16	19	quasi-bidirectional I/O 16
P17	20	quasi-bidirectional I/O 17
A0	21	address input 0
SCL	22	serial clock line input
SDA	23	serial data line input/output
V _{DD}	24	supply voltage

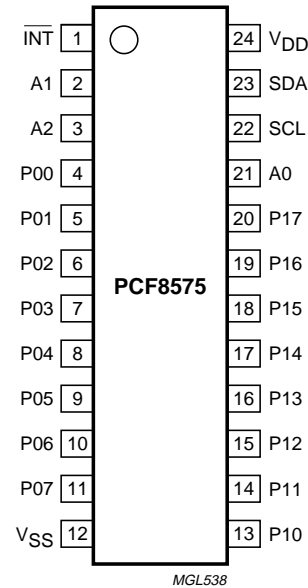

Fig.2 Pin configuration.

Remote 16-bit I/O expander for I²C-bus

PCF8575

6 CHARACTERISTICS OF THE I²C-BUS

The I²C-bus is for bidirectional, 2-line communication between different ICs or modules. The two lines are a serial data line (SDA) and a serial clock line (SCL). Both lines must be connected to a positive supply via a pull-up resistor when connected to the output stages of a device. Data transfer may be initiated only when the bus is not busy.

6.1 Bit transfer

One data bit is transferred during each clock pulse. The data on the SDA line must remain stable during the HIGH period of the clock pulse as changes in the data line at this time will be interpreted as control signals (see Fig.3).

6.2 START and STOP conditions

Both data and clock lines remain HIGH when the bus is not busy. A HIGH-to-LOW transition of the data line, while the clock is HIGH is defined as the START condition (S).

A LOW-to-HIGH transition of the data line while the clock is HIGH is defined as the STOP condition P (see Fig.4).

6.3 System configuration

A device generating a message is a 'transmitter', a device receiving the message is the 'receiver'. The device that controls the message is the 'master' and the devices which are controlled by the master are the 'slaves' (see Fig.5).

6.4 Acknowledge

The number of data bytes transferred between the START and the STOP conditions from transmitter to receiver is not limited. Each byte of eight bits is followed by one acknowledge bit. The transmitter must release the SDA line before the receiver can send an acknowledge bit.

A slave receiver which is addressed must generate an acknowledge after the reception of each byte. Also a master must generate an acknowledge after the reception of each byte that has been clocked out of the slave transmitter. The device that acknowledges has to pull down the SDA line during the acknowledge clock pulse, so that the SDA line is stable LOW during the HIGH period of the acknowledge related clock pulse, set-up and hold times must be taken into account.

A master receiver must signal an end of data to the transmitter by **not** generating an acknowledge after the last byte that has been clocked out of the slave. This is done by the master receiver by holding the SDA line HIGH. In this event the transmitter must release the data line to enable the master to generate a STOP condition.

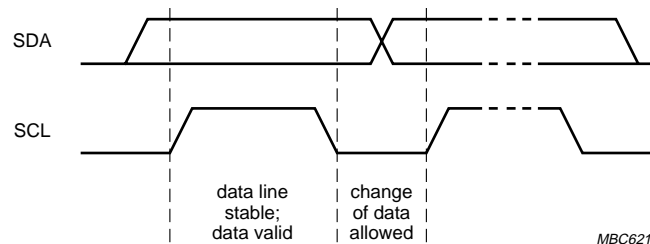
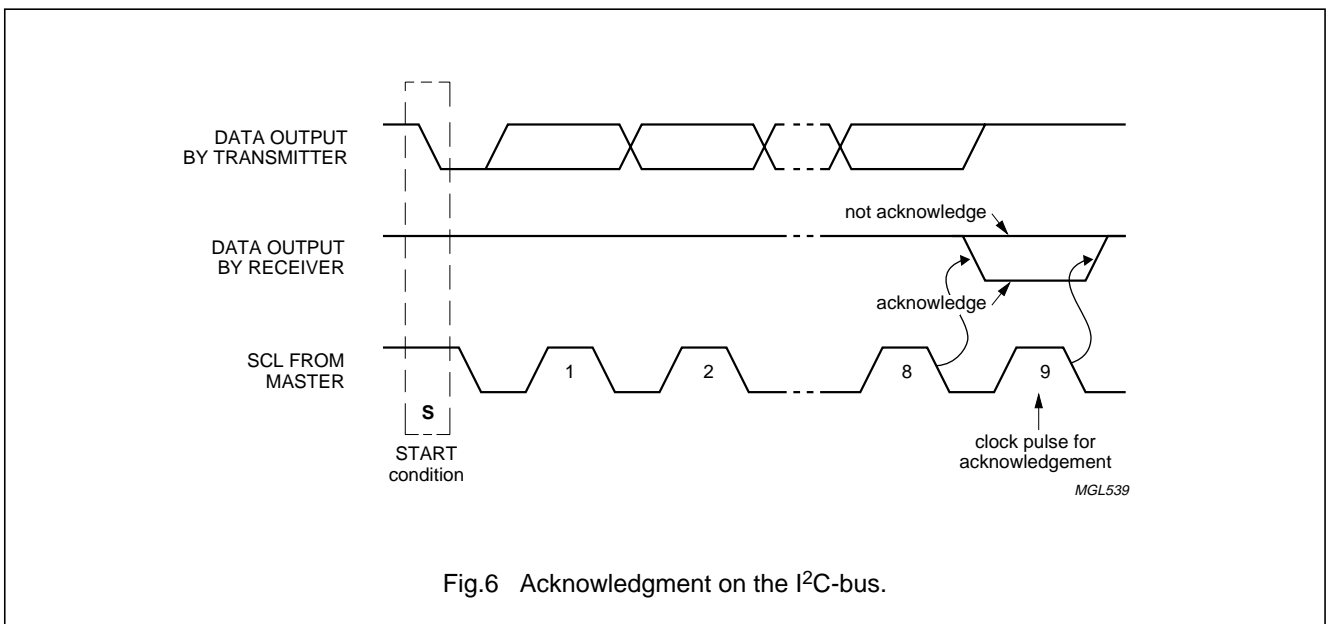
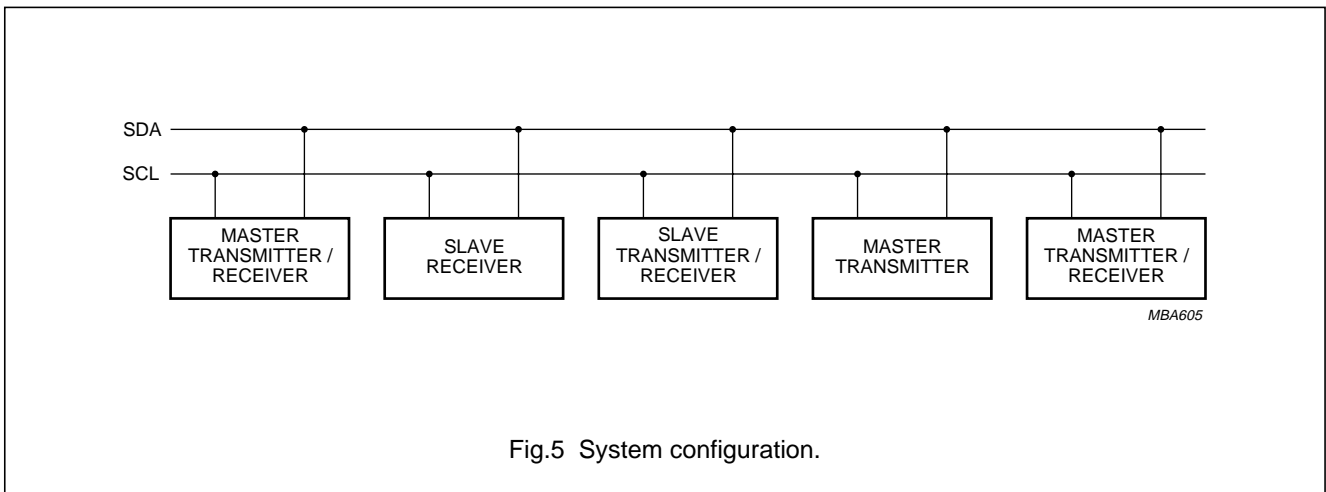
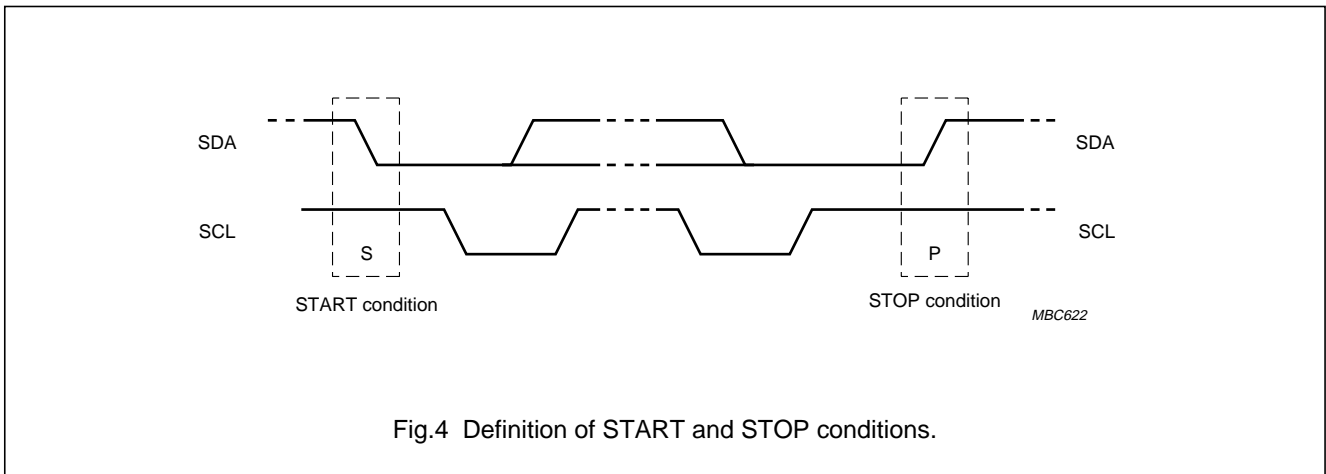

Fig.3 Bit transfer.

Remote 16-bit I/O expander for I²C-bus

PCF8575



Remote 16-bit I/O expander for I²C-bus

PCF8575

7 FUNCTIONAL DESCRIPTION

7.1 Quasi-bidirectional I/Os

The PCF8575's 16 ports (see Fig.7) are entirely independent and can be used either as input or output ports. Input data is transferred from the ports to the microcontroller in the READ mode (see Fig.10). Output data is transmitted to the ports in the WRITE mode (see Fig.9).

This quasi-bidirectional I/O can be used as an input or output without the use of a control signal for data direction. At power-on the I/Os are HIGH. In this mode only a current source (I_{OH}) to V_{DD} is active. An additional strong pull-up to V_{DD} (I_{OHt}) allows fast rising edges into heavily loaded outputs. These devices turn on when an output is written HIGH, and are switched off by the negative edge of SCL. The I/Os should be HIGH before being used as inputs. After power-on as all the I/Os are set HIGH all of them can be used as input. Any change in setting of the I/Os as either inputs or outputs can be done with the write mode. Warning: If a HIGH is applied to an I/O which has been written earlier to LOW, a large current (I_{OL}) will flow to V_{SS} . (see Characteristics note 3).

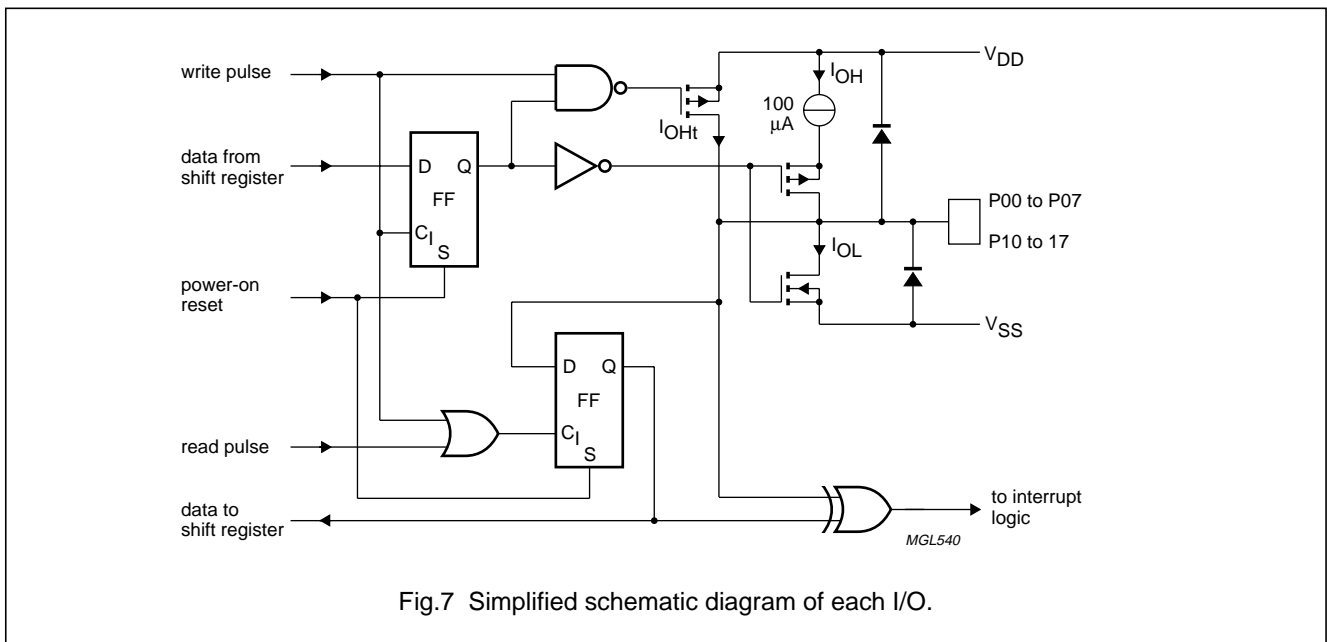

7.2 Addressing

Figures 8, 9 and 10 show the address and timing diagrams. Before any data is transmitted or received the master must send the address of the receiver via the SDA line. The first byte transmitted after the START condition carries the address of the slave device and the read/write bit. The address of the slave device must not be changed between the START and the STOP conditions. The PCF8575 acts as a slave receiver or a slave transmitter.

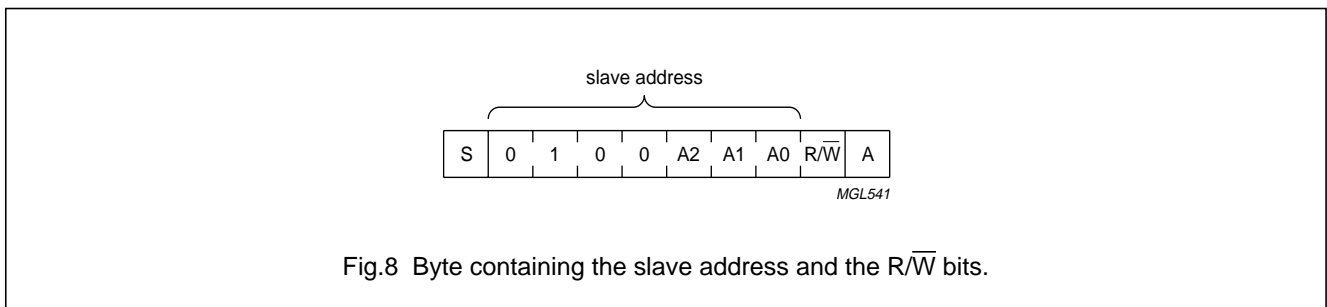

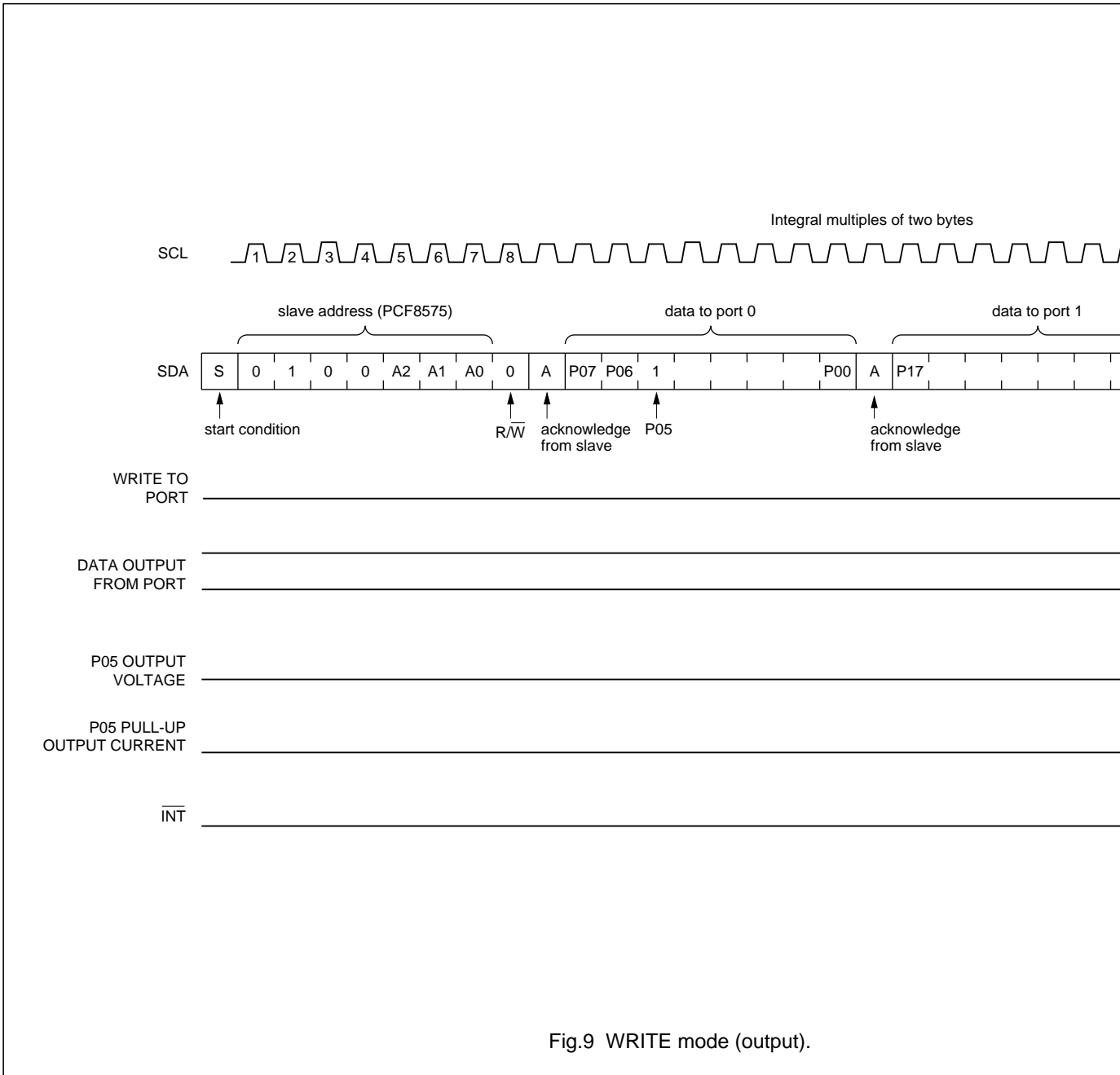
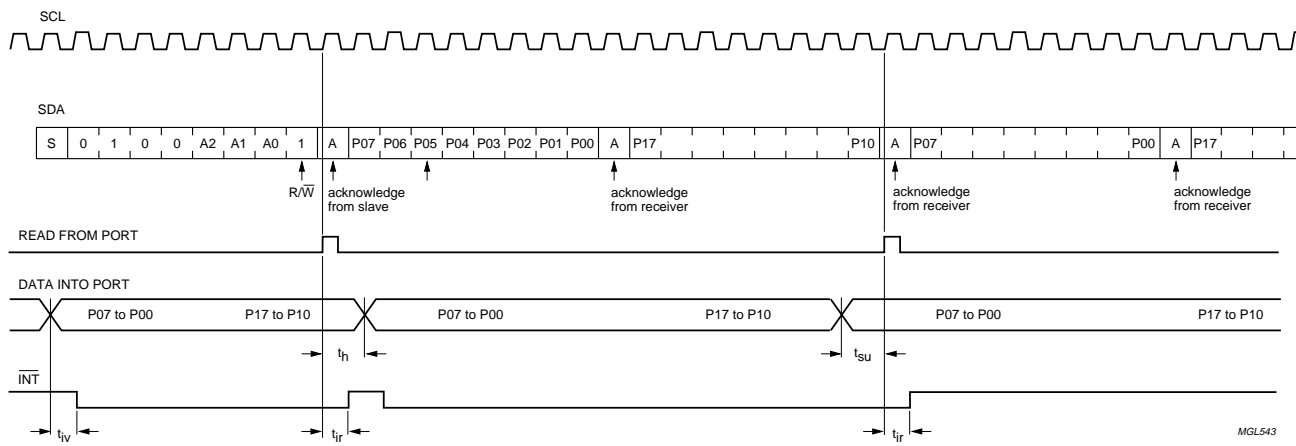

Fig.9 WRITE mode (output).



A LOW-to-HIGH transition of SDA, while SCL is HIGH is defined as the STOP condition (P). Transfer of data can be stopped at any moment by a STOP condition. V at the latest acknowledge phase is valid (output mode). Input data is lost.

Fig.10 READ mode (input).

Remote 16-bit I/O expander for I²C-bus

PCF8575

7.3 Reading from a port (input mode)

All ports programmed as input should be set to logic 1. To read, the master (microcontroller) first addresses the slave device after it receives the interrupt. By setting the last bit of the byte containing the slave address to logic 1 the read mode is entered. The data bytes that follow on the SDA are the values on the ports.

If the data on the input port changes faster than the master can read, this data may be lost.

7.4 Writing to the port (output mode)

To write, the master (microcontroller) first addresses the slave device. By setting the last bit of the byte containing the slave address to logic 0 the write mode is entered. The PCF8575 acknowledges and the master sends the first data byte for P07 to P00. After the first data byte is acknowledged by the PCF8575, the second data byte P17 to P10 is sent by the master. Once again the PCF8575 acknowledges the receipt of the data after which this 16-bit data is presented on the port lines.

The number of data bytes that can be sent successively is not limited. After every two bytes the previous data is overwritten.

The first data byte in every pair refers to Port 0 (P07 to P00), whereas the second data byte in every pair refers to Port 1 (P17 to P10), see Fig.11.

7.5 Interrupt

The PCF8575 provides an open-drain interrupt (\overline{INT}) which can be fed to a corresponding input of the microcontroller (see Figs 9, 10 and 12). This gives these chips a kind of a master function which can initiate an action elsewhere in the system.

An interrupt is generated by any rising or falling edge of the port inputs. After time t_{iv} the signal \overline{INT} is valid.

The interrupt disappears when data on the port is changed to the original setting or data is read from or written to the device which has generated the interrupt.

In the write mode the interrupt may become deactivated (HIGH) on the rising edge of the write to port pulse. On the falling edge of the write to port pulse the interrupt is definitely deactivated (HIGH).

The interrupt is reset in the read mode on the rising edge of the read from port pulse.

During the resetting of the interrupt itself any changes on the I/Os may not generate an interrupt. After the interrupt is reset any change in I/Os will be detected and transmitted as an \overline{INT} .

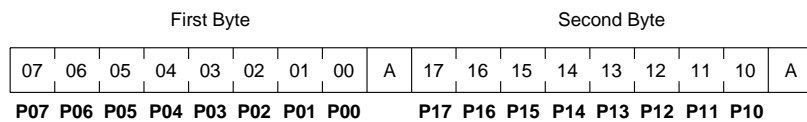

MGL545

Fig.11 Correlation between bits and ports.

Remote 16-bit I/O expander for I²C-bus

PCF8575

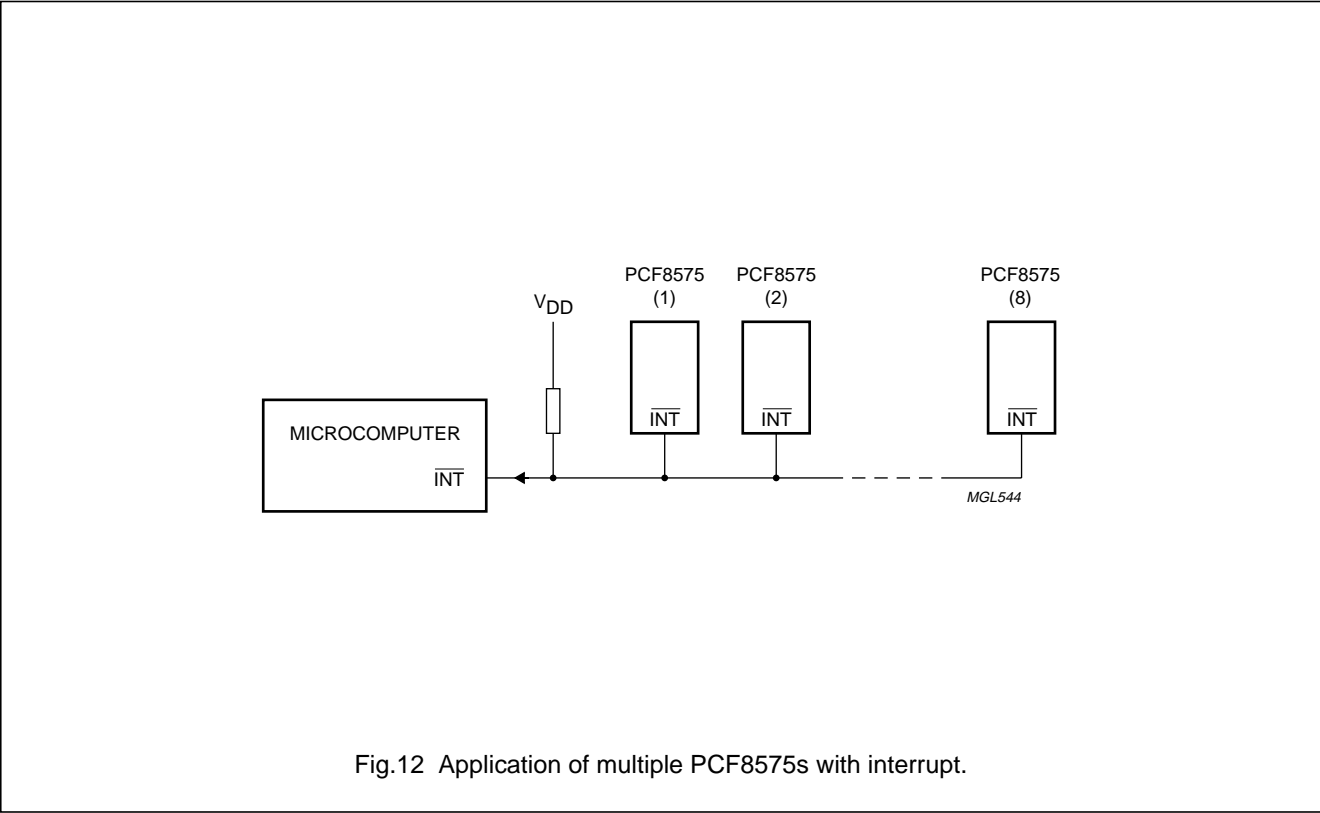

Fig.12 Application of multiple PCF8575s with interrupt.

Remote 16-bit I/O expander for I²C-bus

PCF8575

8 LIMITING VALUES

In accordance with the Absolute Maximum Rating System (IEC 134); note 1.

SYMBOL	PARAMETER	MIN.	MAX.	UNIT
V _{DD}	supply voltage	-0.5	+6.5	V
I _{DD}	supply current	-	±100	mA
I _{SS}	supply current	-	±100	mA
V _I	input voltage	V _{SS} - 0.5	V _{DD} + 0.5	V
I _I	DC input current	-	±20	mA
I _O	DC output current	-	±25	mA
P _{tot}	total power dissipation	-	400	mW
P _O	power dissipation per output	-	100	mW
T _{stg}	storage temperature	-65	+150	°C
T _{amb}	operating ambient temperature	-40	+85	°C

Note

1. Stress above those listed under 'Absolute Maximum Ratings' may cause permanent damage to the device. This is a stress ratings only and functional operation of the device at these or any other conditions above those indicated in the operational sections of this specification is not implied. Exposure to absolute maximum rating conditions for extended periods may affect device reliability.

9 HANDLING

Inputs and outputs are protected against electrostatic discharge in normal handling. However, to be totally safe, it is desirable to take precautions appropriate to handling MOS devices. Advice can be found in Data Handbook IC12 under "Handling MOS Devices".

10 CHARACTERISTICSV_{DD} = 2.5 to 5.5 V; V_{SS} = 0 V; T_{amb} = -40 to +85 °C; unless otherwise specified.

SYMBOL	PARAMETER	CONDITIONS	MIN.	TYP.	MAX.	UNIT
Supplies						
V _{DD}	supply voltage		2.5	-	5.5	V
I _{DD}	supply current	operating mode; no load; V _I = V _{DD} or V _{SS} ; f _{SCL} = 400 kHz	-	100	200	µA
I _{DD(stb)}	standby current	standby mode; no load; V _I = V _{DD} or V _{SS}	-	2.5	10	µA
V _{POR}	power-on reset voltage	note 1	-	1.2	1.8	V
V _{IL1}	LOW-level input voltage pins A0, A1 and A2		0.0	-	0.2V _{DD}	V
V _{IL2}	LOW-level input voltage on all other signal pins		0.0	-	0.3V _{DD}	V
V _{IH}	HIGH-level input voltage		0.7V _{DD}	-	V _{DD}	V
I _{L1}	leakage current at pins A0, A1 and A2	V _I = V _{DD} or V _{SS}	-1	-	+1	µA

Remote 16-bit I/O expander for I²C-bus

PCF8575

SYMBOL	PARAMETER	CONDITIONS	MIN.	TYP.	MAX.	UNIT
I _{L2}	leakage current on all other signal pins	V _I = V _{DD} or V _{SS}	-10	-	+10	μA
Input SCL; input/output SDA						
I _{OL}	LOW-level output current	V _{OL} = 0.4 V; note 3	3	-	-	mA
C _I	input capacitance	V _I = V _{SS} ; note 2	-	-	7	pF
I/Os; P00 to P07 and P10 to P17						
I _{OL}	LOW-level output current	V _{OL} = 1 V; note 3	10	25	-	mA
I _{OH}	HIGH-level output current	V _{OH} = V _{SS}	-30	-	-300	μA
I _{OHt}	transient pull-up current	V _{OH} = V _{SS} ; see Fig.9	-0.5	-1.0	-	mA
C _I	input capacitance	note 2	-	-	10	pF
C _O	output capacitance	note 2	-	-	10	pF
Port timing; C_L ≤ 100 pF (see Figs 9 and 10)						
t _{pv}	output data valid		-	-	4	μs
t _{su}	input data set-up time		0	-	-	μs
t _h	input data hold time		4	-	-	μs
Interrupt $\overline{\text{INT}}$ (see Fig.13)						
I _{OL}	LOW-level output current	V _{OL} = 0.4 V	1.6	-	-	mA
TIMING; C_L ≤ 100 pF (see Figs 9 and 10)						
t _{iv}	input data valid time		-	-	4	μs
t _{ir}	reset delay time		-	-	4	μs

Notes

1. The power-on reset circuit resets the I²C-bus logic with V_{DD} < V_{POR} and sets all I/Os to logic 1 (with current source to V_{DD}).
2. The value is not tested, but verified on sampling basis.
3. A single LOW-level output current (I_{OL}) must not exceed 20 mA for an extended time. The sum of all I_{OLs} at any point in time must not exceed 100 mA.

Remote 16-bit I/O expander for I²C-bus

PCF8575

11 I²C-BUS TIMING CHARACTERISTICS

See Fig.13 and note 1.

SYMBOL	PARAMETER	CONDITIONS	MIN.	MAX.	UNIT
f _{SCL}	SCL clock frequency		–	400	kHz
t _{SW}	tolerable spike width on bus	note 2	–	50	ns
t _{BUF}	BUS free time between a STOP and START condition		1.3	–	μs
t _{SU;STA}	START condition set-up time		0.6	–	μs
t _{HD;STA}	START condition hold time		0.6	–	μs
t _{LOW}	SCL LOW time		1.3	–	μs
t _{HIGH}	SCL HIGH time		0.6	–	μs
t _r	SCL and SDA rise time	note 3	20 + 0.1C _b	300	ns
t _f	SCL and SDA fall time	note 3	20 + 0.1C _b	300	ns
t _{SU;DAT}	data set-up time		100	–	ns
t _{HD;DAT}	data hold time		0	–	ns
t _{SU;STO}	STOP condition set-up time		0.6	–	μs
C _b	capacitive load represented by each bus line		–	400	pF

Notes

1. All the timing values are valid within the operating supply voltage and ambient temperature range and refer to V_{IL} and V_{IH} with an input voltage swing of V_{SS} to V_{DD}.
2. The device inputs SDA and SCL are filtered and will reject spikes on the bus lines of widths less than t_{SW(max)}.
3. The rise and fall times specified here refer to the driver device (PCF8575) and are part of the general fast I²C-bus specification when PCF8575 asserts an acknowledge on SDA, the minimum fall time is 20 ns + 0.1C_b.

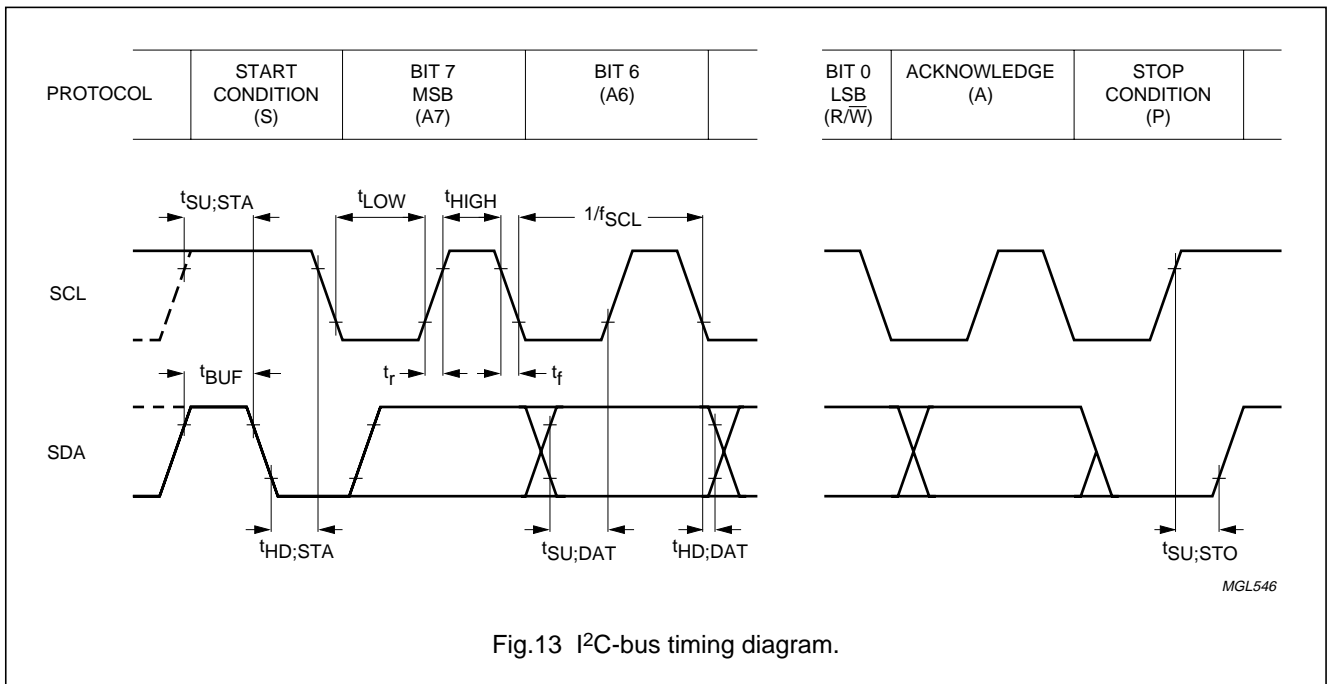

Fig.13 I²C-bus timing diagram.

MGL546

Remote 16-bit I/O expander for I²C-bus

PCF8575

12 DEVICE PROTECTION

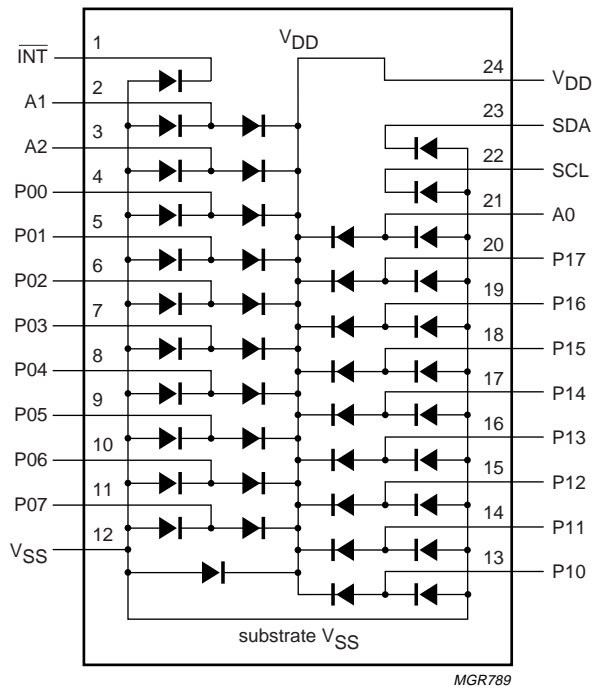

Fig.14 Device protection diagram.

Remote 16-bit I/O expander for I²C-bus

PCF8575

13 PACKAGE OUTLINE

SSOP24: plastic shrink small outline package; 24 leads; body width 5.3 mm

SOT340-1

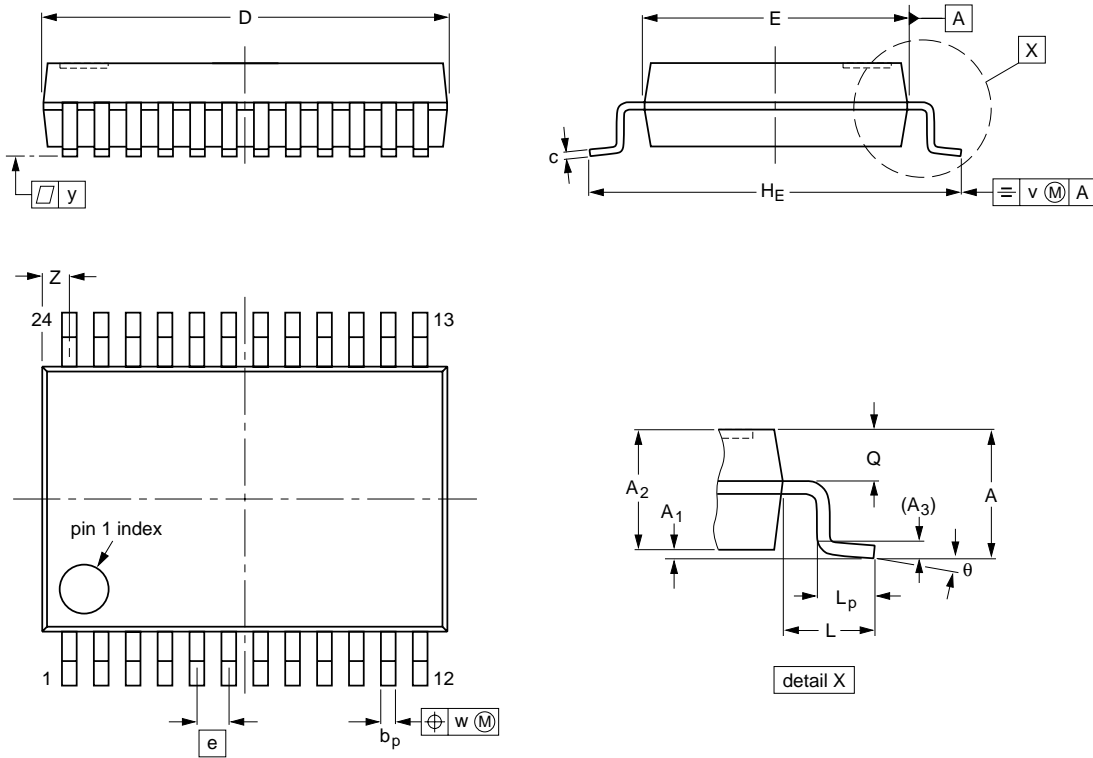

DIMENSIONS (mm are the original dimensions)

UNIT	A max.	A ₁	A ₂	A ₃	b _p	c	D ⁽¹⁾	E ⁽¹⁾	e	H _E	L	L _p	Q	v	w	y	Z ⁽¹⁾	θ
mm	2.0	0.21 0.05	1.80 1.65	0.25	0.38 0.25	0.20 0.09	8.4 8.0	5.4 5.2	0.65	7.9 7.6	1.25	1.03 0.63	0.9 0.7	0.2	0.13	0.1	0.8 0.4	8° 0°

Note

1. Plastic or metal protrusions of 0.20 mm maximum per side are not included.

OUTLINE VERSION	REFERENCES				EUROPEAN PROJECTION	ISSUE DATE
	IEC	JEDEC	EIAJ			
SOT340-1		MO-150AG				93-09-08 95-02-04

Remote 16-bit I/O expander for I²C-bus

PCF8575

14 SOLDERING

14.1 Introduction to soldering surface mount packages

This text gives a very brief insight to a complex technology. A more in-depth account of soldering ICs can be found in our *"Data Handbook IC26; Integrated Circuit Packages"* (document order number 9398 652 90011).

There is no soldering method that is ideal for all surface mount IC packages. Wave soldering is not always suitable for surface mount ICs, or for printed-circuit boards with high population densities. In these situations reflow soldering is often used.

14.2 Reflow soldering

Reflow soldering requires solder paste (a suspension of fine solder particles, flux and binding agent) to be applied to the printed-circuit board by screen printing, stencilling or pressure-syringe dispensing before package placement.

Several methods exist for reflowing; for example, infrared/convection heating in a conveyor type oven. Throughput times (preheating, soldering and cooling) vary between 100 and 200 seconds depending on heating method.

Typical reflow peak temperatures range from 215 to 250 °C. The top-surface temperature of the packages should preferably be kept below 230 °C.

14.3 Wave soldering

Conventional single wave soldering is not recommended for surface mount devices (SMDs) or printed-circuit boards with a high component density, as solder bridging and non-wetting can present major problems.

To overcome these problems the double-wave soldering method was specifically developed.

If wave soldering is used the following conditions must be observed for optimal results:

- Use a double-wave soldering method comprising a turbulent wave with high upward pressure followed by a smooth laminar wave.
- For packages with leads on two sides and a pitch (e):
 - larger than or equal to 1.27 mm, the footprint longitudinal axis is **preferred** to be parallel to the transport direction of the printed-circuit board;
 - smaller than 1.27 mm, the footprint longitudinal axis **must** be parallel to the transport direction of the printed-circuit board.

The footprint must incorporate solder thieves at the downstream end.

- For packages with leads on four sides, the footprint must be placed at a 45° angle to the transport direction of the printed-circuit board. The footprint must incorporate solder thieves downstream and at the side corners.

During placement and before soldering, the package must be fixed with a droplet of adhesive. The adhesive can be applied by screen printing, pin transfer or syringe dispensing. The package can be soldered after the adhesive is cured.

Typical dwell time is 4 seconds at 250 °C.

A mildly-activated flux will eliminate the need for removal of corrosive residues in most applications.

14.4 Manual soldering

Fix the component by first soldering two diagonally-opposite end leads. Use a low voltage (24 V or less) soldering iron applied to the flat part of the lead. Contact time must be limited to 10 seconds at up to 300 °C.

When using a dedicated tool, all other leads can be soldered in one operation within 2 to 5 seconds between 270 and 320 °C.

Remote 16-bit I/O expander for I²C-bus

PCF8575

14.5 Suitability of surface mount IC packages for wave and reflow soldering methods

PACKAGE	SOLDERING METHOD	
	WAVE	REFLOW ⁽¹⁾
HLQFP, HSQFP, HSOP, SMS	not suitable ⁽²⁾	suitable
PLCC ⁽³⁾ , SO	suitable	suitable
LQFP, QFP, TQFP	not recommended ⁽³⁾⁽⁴⁾	suitable
SQFP	not suitable	suitable
SSOP, TSSOP, VSO	not recommended ⁽⁵⁾	suitable

Notes

1. All surface mount (SMD) packages are moisture sensitive. Depending upon the moisture content, the maximum temperature (with respect to time) and body size of the package, there is a risk that internal or external package cracks may occur due to vaporization of the moisture in them (the so called popcorn effect). For details, refer to the Drypack information in the "Data Handbook IC26; Integrated Circuit Packages; Section: Packing Methods".
2. These packages are not suitable for wave soldering as a solder joint between the printed-circuit board and heatsink (at bottom version) can not be achieved, and as solder may stick to the heatsink (on top version).
3. If wave soldering is considered, then the package must be placed at a 45° angle to the solder wave direction. The package footprint must incorporate solder thieves downstream and at the side corners.
4. Wave soldering is only suitable for LQFP, TQFP and QFP packages with a pitch (e) equal to or larger than 0.8 mm; it is definitely not suitable for packages with a pitch (e) equal to or smaller than 0.65 mm.
5. Wave soldering is only suitable for SSOP and TSSOP packages with a pitch (e) equal to or larger than 0.65 mm; it is definitely not suitable for packages with a pitch (e) equal to or smaller than 0.5 mm.

Remote 16-bit I/O expander for I²C-bus

PCF8575

15 DEFINITIONS

Data sheet status	
Objective specification	This data sheet contains target or goal specifications for product development.
Preliminary specification	This data sheet contains preliminary data; supplementary data may be published later.
Product specification	This data sheet contains final product specifications.
Limiting values	
Limiting values given are in accordance with the Absolute Maximum Rating System (IEC 134). Stress above one or more of the limiting values may cause permanent damage to the device. These are stress ratings only and operation of the device at these or at any other conditions above those given in the Characteristics sections of the specification is not implied. Exposure to limiting values for extended periods may affect device reliability.	
Application information	
Where application information is given, it is advisory and does not form part of the specification.	

16 LIFE SUPPORT APPLICATIONS

These products are not designed for use in life support appliances, devices, or systems where malfunction of these products can reasonably be expected to result in personal injury. Philips customers using or selling these products for use in such applications do so at their own risk and agree to fully indemnify Philips for any damages resulting from such improper use or sale.

17 PURCHASE OF PHILIPS I²C COMPONENTS

Purchase of Philips I²C components conveys a license under the Philips' I²C patent to use the components in the I²C system provided the system conforms to the I²C specification defined by Philips. This specification can be ordered using the code 9398 393 40011.

Remote 16-bit I/O expander for I²C-bus

PCF8575

NOTES

Remote 16-bit I/O expander for I²C-bus

PCF8575

NOTES

Remote 16-bit I/O expander for I²C-bus

PCF8575

NOTES

Philips Semiconductors – a worldwide company

Argentina: see South America

Australia: 34 Waterloo Road, NORTH RYDE, NSW 2113,
Tel. +61 2 9805 4455, Fax. +61 2 9805 4466

Austria: Computerstr. 6, A-1101 WIEN, P.O. Box 213,
Tel. +43 1 60 101 1248, Fax. +43 1 60 101 1210

Belarus: Hotel Minsk Business Center, Bld. 3, r. 1211, Volodarski Str. 6,
220050 MINSK, Tel. +375 172 20 0733, Fax. +375 172 20 0773

Belgium: see The Netherlands

Brazil: see South America

Bulgaria: Philips Bulgaria Ltd., Energoproject, 15th floor,
51 James Bourchier Blvd., 1407 SOFIA,
Tel. +359 2 68 9211, Fax. +359 2 68 9102

Canada: PHILIPS SEMICONDUCTORS/COMPONENTS,
Tel. +1 800 234 7381, Fax. +1 800 943 0087

China/Hong Kong: 501 Hong Kong Industrial Technology Centre,
72 Tat Chee Avenue, Kowloon Tong, HONG KONG,
Tel. +852 2319 7888, Fax. +852 2319 7700

Colombia: see South America

Czech Republic: see Austria

Denmark: Sydhavnsgade 23, 1780 COPENHAGEN V,
Tel. +45 33 29 3333, Fax. +45 33 29 3905

Finland: Sinikalliontie 3, FIN-02630 ESPOO,
Tel. +358 9 615 800, Fax. +358 9 6158 0920

France: 51 Rue Carnot, BP317, 92156 SURESNES Cedex,
Tel. +33 1 4099 6161, Fax. +33 1 4099 6427

Germany: Hammerbrookstraße 69, D-20097 HAMBURG,
Tel. +49 40 2353 60, Fax. +49 40 2353 6300

Hungary: see Austria

India: Philips INDIA Ltd, Band Box Building, 2nd floor,
254-D, Dr. Annie Besant Road, Worli, MUMBAI 400 025,
Tel. +91 22 493 8541, Fax. +91 22 493 0966

Indonesia: PT Philips Development Corporation, Semiconductors Division,
Gedung Philips, Jl. Buncit Raya Kav.99-100, JAKARTA 12510,
Tel. +62 21 794 0040 ext. 2501, Fax. +62 21 794 0080

Ireland: Newstead, Clonskeagh, DUBLIN 14,
Tel. +353 1 7640 000, Fax. +353 1 7640 200

Israel: RAPAC Electronics, 7 Kehilat Saloniki St, PO Box 18053,
TEL AVIV 61180, Tel. +972 3 645 0444, Fax. +972 3 649 1007

Italy: PHILIPS SEMICONDUCTORS, Piazza IV Novembre 3,
20124 MILANO, Tel. +39 2 6752 2531, Fax. +39 2 6752 2557

Japan: Philips Bldg 13-37, Kohnan 2-chome, Minato-ku,
TOKYO 108-8507, Tel. +81 3 3740 5130, Fax. +81 3 3740 5077

Korea: Philips House, 260-199 Itaewon-dong, Yongsan-ku, SEOUL,
Tel. +82 2 709 1412, Fax. +82 2 709 1415

Malaysia: No. 76 Jalan Universiti, 46200 PETALING JAYA, SELANGOR,
Tel. +60 3 750 5214, Fax. +60 3 757 4880

Mexico: 5900 Gateway East, Suite 200, EL PASO, TEXAS 79905,
Tel. +9-5 800 234 7381, Fax +9-5 800 943 0087

Middle East: see Italy

Netherlands: Postbus 90050, 5600 PB EINDHOVEN, Bldg. VB,
Tel. +31 40 27 82785, Fax. +31 40 27 88399

New Zealand: 2 Wagener Place, C.P.O. Box 1041, AUCKLAND,
Tel. +64 9 849 4160, Fax. +64 9 849 7811

Norway: Box 1, Manglerud 0612, OSLO,
Tel. +47 22 74 8000, Fax. +47 22 74 8341

Pakistan: see Singapore

Philippines: Philips Semiconductors Philippines Inc.,
106 Valero St. Salcedo Village, P.O. Box 2108 MCC, MAKATI,
Metro MANILA, Tel. +63 2 816 6380, Fax. +63 2 817 3474

Poland: Ul. Lukiska 10, PL 04-123 WARSZAWA,
Tel. +48 22 612 2831, Fax. +48 22 612 2327

Portugal: see Spain

Romania: see Italy

Russia: Philips Russia, Ul. Usatcheva 35A, 119048 MOSCOW,
Tel. +7 095 755 6918, Fax. +7 095 755 6919

Singapore: Lorong 1, Toa Payoh, SINGAPORE 319762,
Tel. +65 350 2538, Fax. +65 251 6500

Slovakia: see Austria

Slovenia: see Italy

South Africa: S.A. PHILIPS Pty Ltd., 195-215 Main Road Martindale,
2092 JOHANNESBURG, P.O. Box 7430 Johannesburg 2000,
Tel. +27 11 470 5911, Fax. +27 11 470 5494

South America: Al. Vicente Pinzon, 173, 6th floor,
04547-130 SÃO PAULO, SP, Brazil,
Tel. +55 11 821 2333, Fax. +55 11 821 2382

Spain: Balmes 22, 08007 BARCELONA,
Tel. +34 93 301 6312, Fax. +34 93 301 4107

Sweden: Kottbygatan 7, Akalla, S-16485 STOCKHOLM,
Tel. +46 8 5985 2000, Fax. +46 8 5985 2745

Switzerland: Allmendstrasse 140, CH-8027 ZÜRICH,
Tel. +41 1 488 2741 Fax. +41 1 488 3263

Taiwan: Philips Semiconductors, 6F, No. 96, Chien Kuo N. Rd., Sec. 1,
TAIPEI, Taiwan Tel. +886 2 2134 2886, Fax. +886 2 2134 2874

Thailand: PHILIPS ELECTRONICS (THAILAND) Ltd.,
209/2 Sanpavuth-Bangna Road Prakanong, BANGKOK 10260,
Tel. +66 2 745 4090, Fax. +66 2 398 0793

Turkey: Talatpasa Cad. No. 5, 80640 GÜLTEPE/ISTANBUL,
Tel. +90 212 279 2770, Fax. +90 212 282 6707

Ukraine: PHILIPS UKRAINE, 4 Patrice Lumumba str., Building B, Floor 7,
252042 KIEV, Tel. +380 44 264 2776, Fax. +380 44 268 0461

United Kingdom: Philips Semiconductors Ltd., 276 Bath Road, Hayes,
MIDDLESEX UB3 5BX, Tel. +44 181 730 5000, Fax. +44 181 754 8421

United States: 811 East Arques Avenue, SUNNYVALE, CA 94088-3409,
Tel. +1 800 234 7381, Fax. +1 800 943 0087

Uruguay: see South America

Vietnam: see Singapore

Yugoslavia: PHILIPS, Trg N. Pasica 5/v, 11000 BEOGRAD,
Tel. +381 11 62 5344, Fax. +381 11 63 5777

For all other countries apply to: Philips Semiconductors,
International Marketing & Sales Communications, Building BE-p, P.O. Box 218,
5600 MD EINDHOVEN, The Netherlands, Fax. +31 40 27 24825

Internet: <http://www.semiconductors.philips.com>

© Philips Electronics N.V. 1999

SCA63

All rights are reserved. Reproduction in whole or in part is prohibited without the prior written consent of the copyright owner.

The information presented in this document does not form part of any quotation or contract, is believed to be accurate and reliable and may be changed without notice. No liability will be accepted by the publisher for any consequence of its use. Publication thereof does not convey nor imply any license under patent- or other industrial or intellectual property rights.

Printed in The Netherlands

465006/00/03/pp24

Date of release: 1999 Apr 07

Document order number: 9397 750 05528

Let's make things better.

**Philips
Semiconductors**



PHILIPS

X-ON Electronics

Largest Supplier of Electrical and Electronic Components

Click to view similar products for [Interface - I/O Expanders](#) category:

Click to view products by [NXP](#) manufacturer:

Other Similar products are found below :

[PCA9654EDR2G](#) [LA79200V-TLM-E](#) [LC709006V-E](#) [LC709006V-TLM-E](#) [NLVPCA9535EDTR2G](#) [MAX7329AWE+T](#) [MAX7313ATG+T](#)
[MAX7310AUET](#) [MAX7301ATL+T](#) [MAX7317ATE+T](#) [MAX7310AEE+T](#) [MAX7318AUG+T](#) [TC7SPN334L6X,LF\(S](#) [MAX7300ATL+T](#)
[MAX7317AEE+T](#) [MAX7320ATE+T](#) [MAX7321ATE+T](#) [PI4IOE5V6408ZTAEX](#) [MAX7319AEE+T](#) [MAX7301AAI+T](#) [MAX7312AWG+T](#)
[PCAL6416AEX1Z](#) [PI4IOE5V9554LEX](#) [MAX7322ATE+T](#) [CLCS82C55AZ](#) [PI4IOE5V9555LEX](#) [XP8255](#) [PI4IOE5V6534Q2ZLWEX](#)
[MCP23009T-E/SS](#) [MCP25055-IP](#) [MCP23S18T-E/MJ](#) [MD82C59A/B](#) [TMC424](#) [DS90C385AMT](#) [PCA9539AHF,128](#) [PCAL9554BPWJ](#)
[MCP23017T-E/ML](#) [MAX7319AEE+](#) [MAX7311AWG](#) [MAX7311ATG+T](#) [MAX7301ATL+](#) [MAX7301AAX+](#) [MAX7300ATL+](#)
[MAX7323AEE](#) [MAX7314ATG+](#) [MAX7306AUB+](#) [DS4520ETRL](#) [DS4520E+](#) [PCF8575DB](#) [MAX7301AAX+T](#)