

- Limited Lifetime Warranty
- Medical Approvals
- Universal Input (85 - 265VAC)
- High Efficiency
- Broad 30W to 1500W product range
- RoHS Compliant Design

HWS-/ME Series

Single Output
Medical Power Supplies

Key Market Segments & Applications



Medical

Industrial

Test

Broadcast

Comm

LED

Cots

HWS-/ME Features and Benefits

Features

- Limited Lifetime Warranty
- Medical Approvals
- Wide Range AC Input

Benefits

- Lower Cost of Ownership
- Reduces System Approval Times
- Supports Global Use

Specifications

ITEM	MODELS		HWS30A	HWS100A	HWS300	HWS600	HWS1000	HWS1500
			HWS50A	HWS150A				
Input Voltage range			85-265VAC (47-63Hz)		85-265VAC (47-63Hz)		85-265VAC (47-63Hz)	
Input Current (Typ)	(1)	A	0.65 / 0.4	1.3 / 0.65	4.1 / 2.1	8.1 / 3.9	13.5/7.0	19/10
Inrush Current	(1)	A	14 / 28		20 / 40			
Power Factor / Flicker			Meets EN61000-3-2, EN61000-3-3					
Temperature Coefficient			<0.02%/°C					
Overcurrent Protection			>104%					
Overvoltage Protection		V	Yes (See table on page 2)					
Hold Up Time (Typ)		ms	20					
Leakage Current (60Hz)	(2)	mA	<0.5mA					
Remote Sense			No		Yes			
Indicator			Green LED = ON					
Remote On/Off			No		Yes (Isolated from output)			
Parallel operation			No		Single wire conn. (5 units max)			
DC Good			No		Yes			
Voltage Programming			No					Yes
Operating Temperature and Derating			HWS30A-150A: -10°C to +70°C, (derating applies above 50°C please refer to individual model specification for derating graph) HWS300-1500: -10°C to +70°C, (-10 to +50°C: 100%, derate linearly to 50% load from +50°C to +70°C)					
Storage Temperature		°C	-30°C to +85°C					
Humidity (non condensing)			Operating: 30 - 90%RH (10 -90% on HWS300-1500), Non operating 10 - 95%RH					
Cooling			Convection			Internal fan		
Withstand Voltage	(3)		Input to Ground 2kVAC, Input to Output 3kVAC, Output to Ground 500VAC for 1 min.					
Isolation Resistance			>100MΩ at 25°C & 70%RH, Output to Ground 500VDC, >10MΩ Output to remote on/off 100VDC					
Vibration (non operating)			10 - 55Hz (1 min sweep), 19.6m/s ² constant, X, Y, Z axis, one hour each					
Shock (in packaging)			< 196.1m/s ²					
Safety Agency Approvals	(2)		ES60601-1, EN60601-1, CSA-C22.2 No6011-M90 (C-UL) (basic insulation), CE Mark					
Line Dip			Complies with SEMI F47 (200VAC line only)					
Conducted & Radiated EMI Immunity			EN55011 / EN55022-B, FCC-B, VCCI-B (HWS600 & 1500 Class A) IEC61000-4-2, -3, -4, -6, -8, -11, IEC61000-6-2					
Weight (Typ)		g	220	450	1000	1600	3200	3800
Size (WxHxD)			26 x 82 x 95	33 x 82 x 160				
(with cover except 30 & 50W)		mm	26 x 82 x 120	42 x 82 x 160	61 x 82 x 165	100 x 82 x 165	126.5 x 82 x 240	280 x 82 x 126.5
Warranty			Limited Lifetime Warranty (See TDK-Lambda terms & conditions)					

Notes: (1) 100/200VAC input (2) See clause 19.5DV.2 of UL60601 for equipment in proximity of patient (3) HWS300-600 2.5kVAC Input to ground

Model Selector									
Model	Voltage	Adjust Range	Max Curr(A) ⁴	Max Power(W)	Load Reg(mV)	Line Reg(mV)	Ripple Noise(mV)	Overvoltage (V)	Efficiency (typ)% ¹
HWS30A-5/ME	5V	4.0 - 6.0	6	30	40	20	120	6.25-7.25	77/80
HWS50A-5/ME	5V	4.0 - 6.0	10	50	40	20	120	6.25-7.25	82/84
HWS100A-5/ME	5V	4.0 - 6.0	20	100	40	20	120	6.25-7.25	83/86
HWS150A-5/ME	5V	4.0 - 6.0	30	150	40	20	120	6.25-7.25	83/86
HWS600-5/ME	5V	4.0 - 6.0	120	600	30	20	120	6.25-7.25	80/83
HWS30A-12/ME	12V	9.6 - 14.4	2.5	30	96	48	150	15-17.4	81/83
HWS50A-12/ME	12V	9.6 - 14.4	4.3	51.6	96	48	150	15-17.4	81/83
HWS100A-12/ME	12V	9.6 - 14.4	8.5	102	96	48	150	15-17.4	83/86
HWS150A-12/ME	12V	9.6 - 14.4	13	156	96	48	150	15-17.4	83/86
HWS300-12/ME	12V	9.6 - 14.4	27	324	72	48	150	15-17.4	80/83
HWS600-12/ME	12V	9.6 - 14.4	53	636	72	48	150	15-17.4	80/83
HWS30A-15/ME	15V	12.0 - 18.0	2	30	120	60	150	18.8-21.8	81/83
HWS50A-15/ME	15V	12.0 - 18.0	3.5	52.5	120	60	150	18.8-21.8	81/83
HWS100A-15/ME	15V	12.0 - 18.0	7	105	120	60	150	18.8-21.8	83/86
HWS150A-15/ME	15V	12.0 - 18.0	10	150	120	60	150	18.8-21.8	83/86
HWS300-15/ME	15V	12.0 - 18.0	22	330	90	60	150	18.8-21.8	82/85
HWS600-15/ME	15V	12.0 - 18.0	43	645	90	60	150	18.8-21.8	81/84
HWS30A-24/ME	24V	19.2 - 28.8	1.3	31.2	192	96	200	30-34.8	83/86
HWS50A-24/ME	24V	19.2 - 28.8	2.2	52.8	192	96	150	30-34.8	82/84
HWS100A-24/ME	24V	19.2 - 28.8	4.5	108	192	96	150	30-34.8	84/87
HWS150A-24/ME	24V	19.2 - 28.8	6.5	156	192	96	150	30-34.8	85/88
HWS300-24/ME	24V	19.2 - 28.8	14 (16.5 pk)	336	144	96	150	30-34.8	82/85
HWS600-24/ME	24V	19.2 - 28.8	27 (31 pk)	648	144	96	150	30-34.8	82/85
HWS1000-24/ME	24V	19.2 - 28.8	46 (58.5 pk)	1104	150	96	150	30-34.8	85/87
HWS1500-24/ME	24V	4.8 - 28.8 ⁽⁷⁾	65/70 ⁽¹⁾ (105pk ⁽⁵⁾)	1560/1680 ⁽¹⁾ (2520 pk ⁽⁵⁾)	144	96	200	30-34.8	84/88
HWS1000-36/ME	36V	28.8 - 43.2	30.7 (39 pk)	1104	150	144	200	45-49.7	85/88
HWS1500-36/ME	36V	7.2 - 43.2 ⁽⁶⁾	42/46.5 ⁽¹⁾ (70 pk) ⁽⁵⁾	1512/1674 ⁽¹⁾ (2520 pk ⁽⁵⁾)	150	144	200	34-49.7	84/88
HWS30A-48/ME	48V	38.4 - 52.8	0.65	31.2	384	192	200	55.2-64.8	82/83
HWS50A-48/ME	48V	38.4 - 52.8	1.1	52.8	384	192	200	55.2-64.8	83/85
HWS100A-48/ME	48V	38.4 - 52.8	2.1	100.8	384	192	200	55.2-64.8	84/87
HWS150A-48/ME	48V	38.4 - 52.8	3.3	158.4	384	192	200	55.2-64.8	85/88
HWS300-48/ME	48V	38.4 - 52.8	7	336	288	192	350	55.2-64.8	82/85
HWS600-48/ME	48V	38.4 - 52.8	13	624	288	192	350	55.2-64.8	83/86
HWS1000-48/ME	48V	38.4 - 52.8	23	1104	300	192	200	55.2-60	86/88
HWS1500-48/ME	48V	9.6 - 52.8 ⁽⁶⁾	32	1536	288	192	200	55.2-64.8	86/90

- (4) Peak load for 10s maximum on time, 35% duty cycle (5) 200-265AC Input
 (6) Using voltage programming input - see installation manual for details

Options	
Suffix	Description
Blank	No cover (except HWS300-1500 cover fitted) as standard
/A	Cover fitted (egHWSA100-24/MEA) option available for HWSA100 & HWSA150 only

Outline Drawing HWS100A/MEA Series

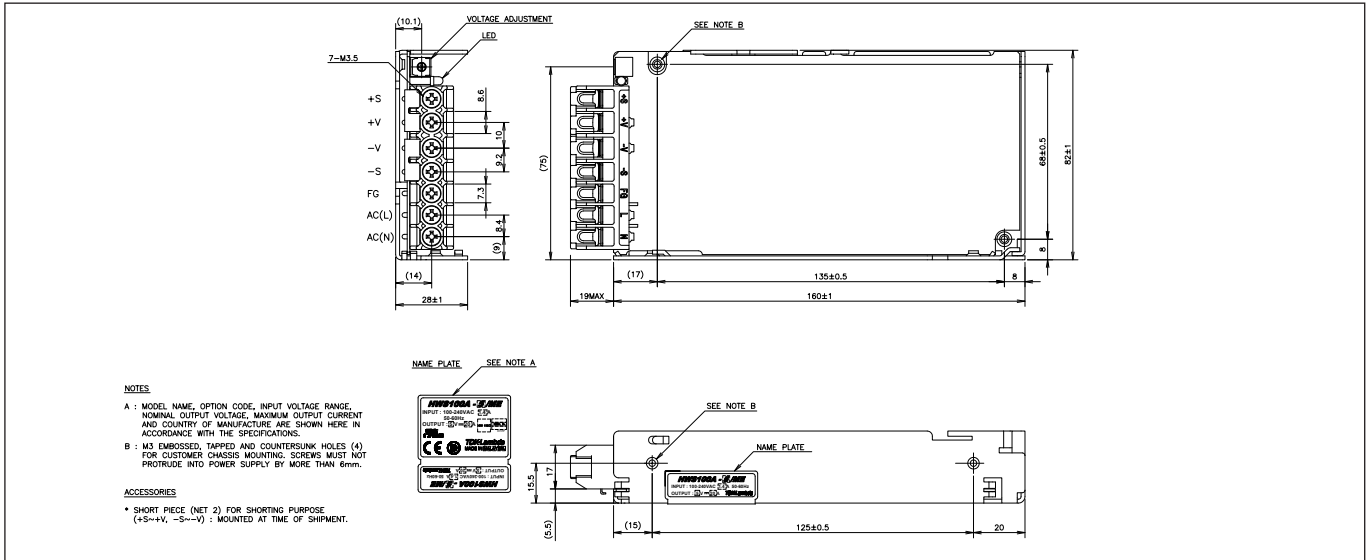

Outline Drawing HWS300 Series

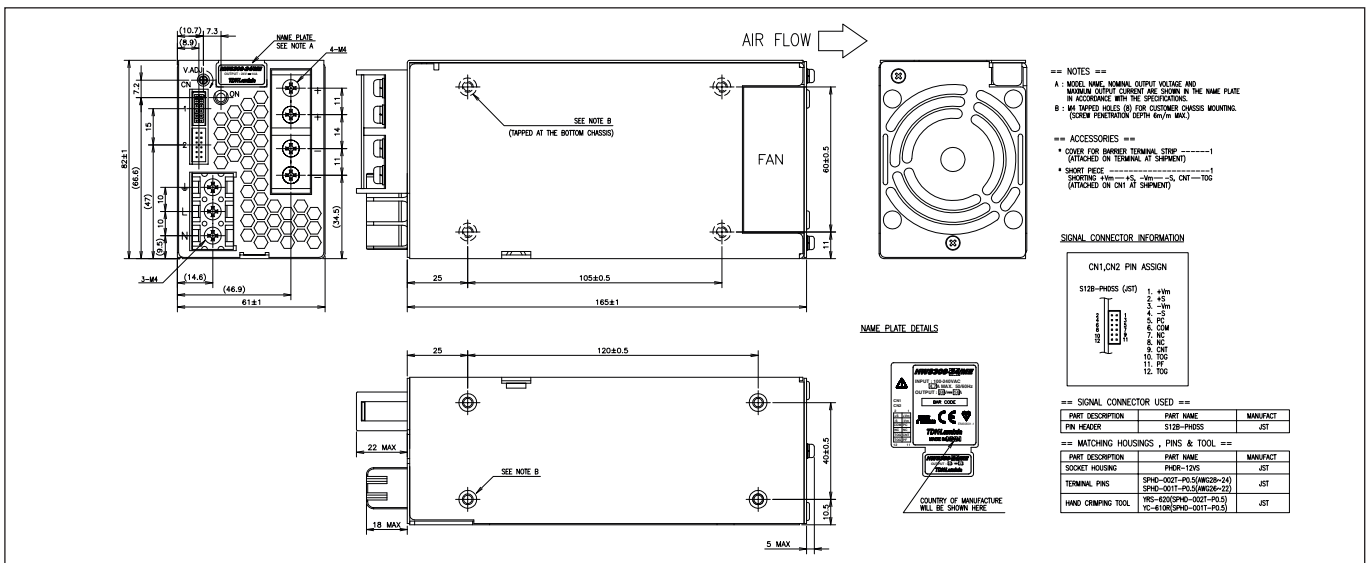

Outline Drawing HWS1500 Series

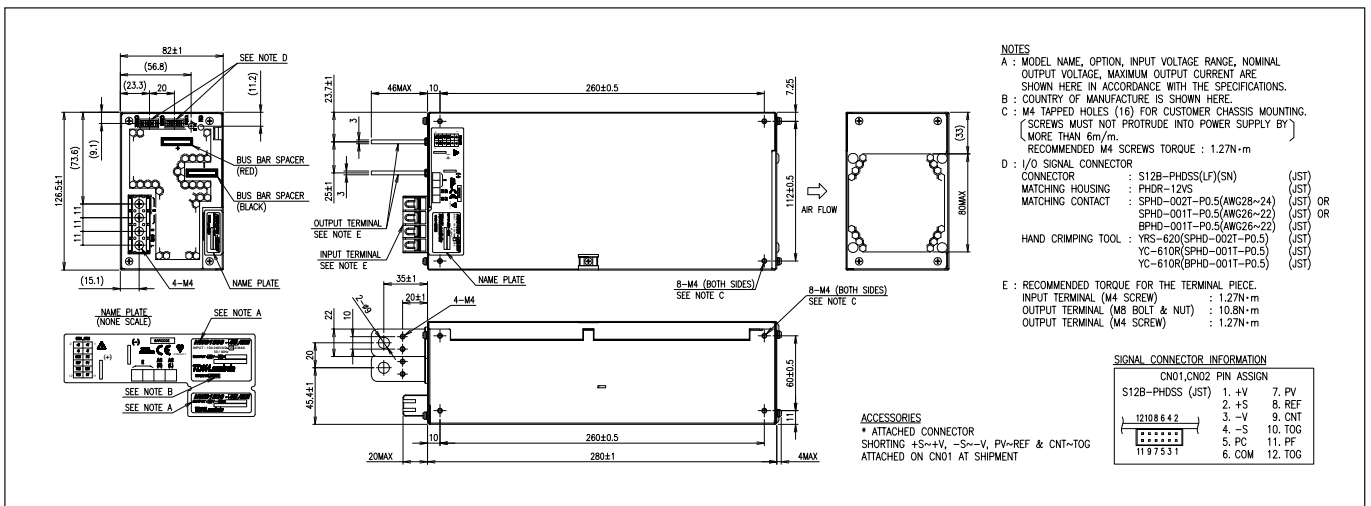



TDK-Lambda France SAS

ZAC des Delaches
 CS 41077
 9 rue Thuillere
 91978 Villebon Courtaboeuf
 France
 Tel: +33 1 60 12 71 65
 Fax: +33 1 60 12 71 66
france@fr.tdk-lambda.com
www.fr.tdk-lambda.com



Italy Sales Office

Via dei Lavoratori 128/130
 20092 Cinisello Balsamo (MI)
 Italy
 Tel: +39 02 61 29 38 63
 Fax: +39 02 61 29 09 00
info.italia@it.tdk-lambda.com
www.it.tdk-lambda.com



Netherlands

info@tdk-lambda.nl
www.tdk-lambda.nl



TDK-Lambda Germany GmbH

Karl-Bold-Strasse 40
 77855 Achern
 Germany
 Tel: +49 7841 666 0
 Fax: +49 7841 5000
info.germany@de.tdk-lambda.com
www.de.tdk-lambda.com



Austria Sales Office

Aredstrasse 22
 2544 Leobersdorf
 Austria
 Tel: +43 2256 655 84
 Fax: +43 2256 645 12
info.germany@de.tdk-lambda.com
www.de.tdk-lambda.com



Scandinavia Sales Office

Valdemarsgade 7
 4100 Ringsted
 Denmark
 Tel: +45 24 63 95 65
 Fax: +45 69 80 44 99
info@de.tdk-lambda.com
www.emea.tdk-lambda.com



Switzerland Sales Office

Bahnhofstrasse 50
 8305 Dietlikon
 Switzerland
 Tel: +41 44 850 53 53
 Fax: +41 44 850 53 50
info@de.tdk-lambda.com
www.de.tdk-lambda.com



TDK-Lambda UK Ltd.

Kingsley Avenue
 Ilfracombe
 Devon EX34 8ES
 United Kingdom
 Tel: +44 (0) 12 71 85 66 66
 Fax: +44 (0) 12 71 86 48 94
powersolutions@uk.tdk-lambda.com
www.uk.tdk-lambda.com



TDK-Lambda Ltd.

Kibbutz
 Givat Hashlosha 48800
 Israel
 Tel: +9 723 902 4333
 Fax: +9 723 902 4777
info@tdk-lambda.co.il
www.tdk-lambda.co.il



C.I.S.

Commercial Support:
 Tel: +7 (495) 665 2627
Technical Support:
 Tel: +7 (812) 658 0463
info@tdk-lambda.ru
www.tdk-lambda.ru

Local Distribution

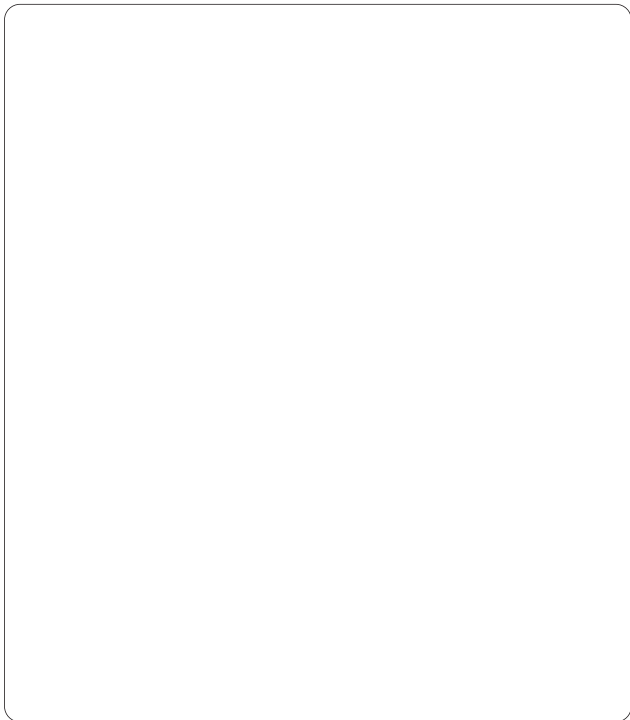

www.emea.tdk-lambda.com

X-ON Electronics

Largest Supplier of Electrical and Electronic Components

Click to view similar products for [Switching Power Supplies](#) category:

Click to view products by [TDK-Lambda](#) manufacturer:

Other Similar products are found below :

[70841011](#) [73-551-0005](#) [AAD600S-4-OP](#) [R22095](#) [HWS50A-5/RA](#) [KD0204](#) [9021](#) [S-15F-12](#) [LDIN100150](#) [LPM000-BBAR-01](#) [LPX17S-C](#)
[EVS57-10R6/R](#) [FDC40-24S12](#) [FRV7000G](#) [22929](#) [CQM1IA121](#) [40370121900](#) [VI-PU22-EXX](#) [40370121910](#) [LDIN5075](#) [432703037161](#)
[WRB01X-U](#) [LPX140-C](#) [08-30466-1040G](#) [09-160CFG](#) [70841004](#) [70841025](#) [VPX3000-CBL-DC](#) [LPM000-BBAR-05](#) [LPM000-BBAR-08](#)
[LPM124-OUTA1-48](#) [LPM000-BBAR-07](#) [LPM109-OUTA1-10](#) [LPM616-CHAS](#) [08-30466-1055G](#) [08-30466-2175G](#) [DMB-EWG](#) [TVQF-](#)
[1219-18S](#) [6504-226-2101](#) [CQM1IPS01](#) [XPFM201A+](#) [MAP80-4000G](#) [LFP300F-24-TY](#) [SMP21-L20-DC24V-5A](#) [VI-MUL-ES](#) [08-30466-](#)
[0065G](#) [CME240P-24](#) [VI-RU031-EWWX](#) [08-30466-0028G](#) [S82Y-TS01](#)