

Chip Beads

For power line

ACC series

Type:	HFxxACC2012	[0805 inch]*
	HFxxACC3216	[1206 inch]
	HFxxACC3225	[1210 inch]
	HFxxACC4532	[1812 inch]

* Dimensions Code [EIA]

Issue date: September 2012

- All specifications are subject to change without notice.
- Conformity to RoHS Directive: This means that, in conformity with EU Directive 2002/95/EC, lead, cadmium, mercury, hexavalent chromium, and specific bromine-based flame retardants, PBB and PBDE, have not been used, except for exempted applications.

Chip Beads

For Power Line

Conformity to RoHS Directive

ACC Series

HFxxACC2012, HFxxACC3216, HFxxACC3225, HFxxACC4532

FEATURES

- With 4 types rated at 1.5A and 3 types rated at 3A, and with a range of frequency characteristics available for each type, the ACC series facilitates selection of the most appropriate part for any given application.
- Effective EMC suppression over a broad band can be achieved simply by inserting this product into the DC power line on the circuit board.
- Available reflow soldering.
- It is a product conforming to RoHS directive.



PRODUCT IDENTIFICATION

HF70 ACC 201209 - T
(1) (2) (3) (4)

(1) Material name

(2) Series name

(3) Dimension code

(4) Packaging style

T: ϕ 180mm reel taping

TL: ϕ 330mm reel taping

SPECIFICATIONS

Operating temperature range	-40 to +125°C
Storage temperature range	-40 to +125°C(After mount)

PACKAGING STYLE AND QUANTITIES

Packaging style	Type	Quantity
Taping	201209	2000 pieces/reel
	321611	2000 pieces/reel
	322513	2000 pieces/reel
	453215	1000 pieces/reel

HANDLING AND PRECAUTIONS

- Before soldering, be sure to preheat components. The preheating temperature should be set so that the temperature difference between the solder temperature and product temperature does not exceed 150°C.
- After mounting components onto the printed circuit board, do not apply stress through board bending or mishandling.
- Do not expose the inductors to stray magnetic fields.
- Avoid static electricity discharge during handling.
- When hand soldering, apply the soldering iron to the printed circuit board only. Temperature of the iron tip should not exceed 350°C. Soldering time should not exceed 3 seconds.

SHAPES AND DIMENSIONS/CIRCUIT DIAGRAM

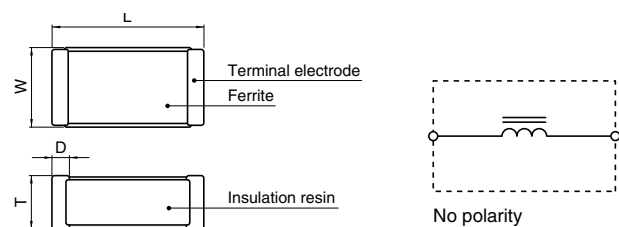

Dimensions in mm

Type	L	W	T	D
201209	2.0±0.2	1.25±0.2	0.9±0.2	0.3±0.2
321611	3.2±0.2	1.6±0.2	1.1±0.2	0.3±0.2
322513	3.2±0.2	2.5±0.2	1.3±0.2	0.3±0.2
453215	4.5±0.25	3.2±0.25	1.5±0.25	0.3±0.2

- Dimension without tolerance is reference value.

RECOMMENDED PC BOARD PATTERN REFLOW SOLDERING

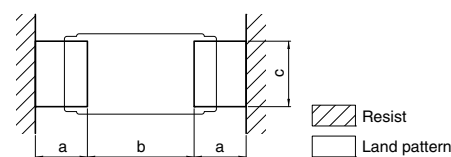

Dimensions in mm

Type	a	b	c
201209	1.0	1.0	1.0
321611	1.1	2.2	1.4
322513	1.1	2.2	2.3
453215	1.5	3.0	3.0

• Conformity to RoHS Directive: This means that, in conformity with EU Directive 2002/95/EC, lead, cadmium, mercury, hexavalent chromium, and specific bromine-based flame retardants, PBB and PBDE, have not been used, except for exempted applications.

• Please contact our Sales office when your application is considered the following:

The device's failure or malfunction may directly endanger human life (e.g. application for automobile/aircraft/medical/nuclear power devices, etc.)

• All specifications are subject to change without notice.

ELECTRICAL CHARACTERISTICS

Shape	Part No.	Impedance (Ω)[100MHz]	DC resistance (Ω)max.	Rated current (A)max.
201209	HF70ACC201209	10 \pm 25%	0.03	1.5
	HF50ACC201209	11 \pm 25%	0.03	1.5
	HF30ACC201209	7 \pm 25%	0.03	1.5
321611	HF70ACC321611	26 \pm 25%	0.04	1.5
	HF50ACC321611	31 \pm 25%	0.04	1.5
	HF30ACC321611	19 \pm 25%	0.04	1.5
322513	HF70ACC322513	52 \pm 25%	0.05	1.5
	HF50ACC322513	60 \pm 25%	0.05	1.5
	HF30ACC322513	31 \pm 25%	0.05	1.5
453215	HF70ACC453215	120 \pm 25%	0.05	1.5
	HF50ACC453215	125 \pm 25%	0.05	1.5
	HF30ACC453215	70 \pm 25%	0.05	1.5

RECOMMENDED SOLDERING CONDITION REFLOW SOLDERING

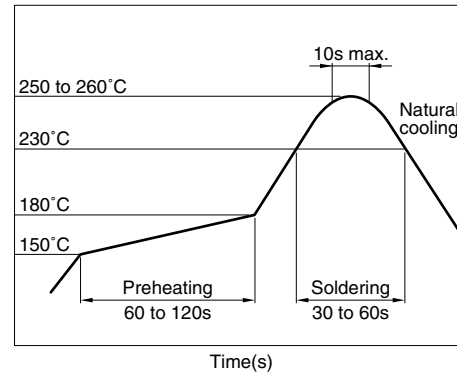

TYPICAL ELECTRICAL CHARACTERISTICS Z, X, R vs. FREQUENCY CHARACTERISTICS

HF70ACC201209

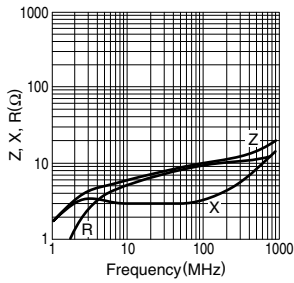

HF50ACC201209

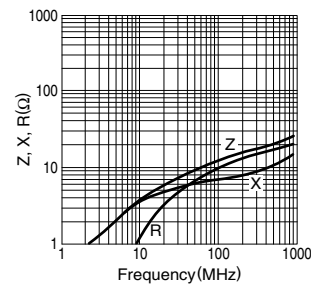

HF30ACC201209

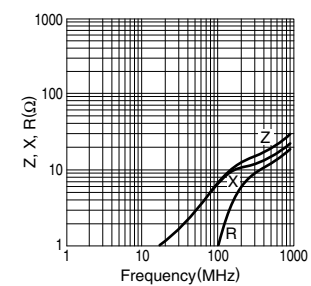

HF70ACC321611

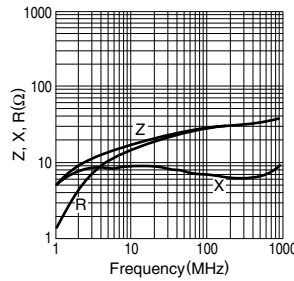

HF50ACC321611

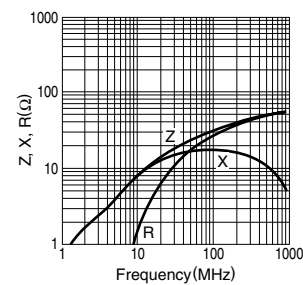

HF30ACC321611

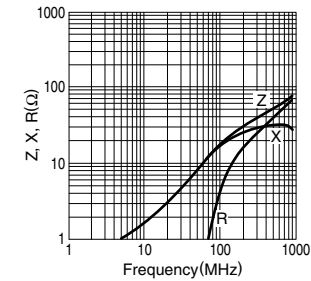

HF70ACC322513

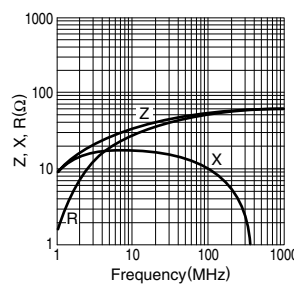

HF50ACC322513

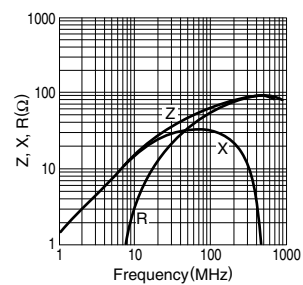

HF30ACC322513

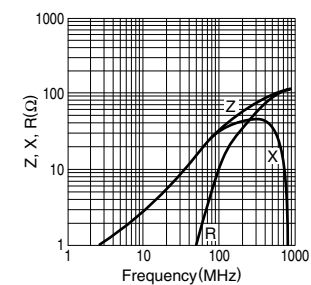

• TEST EQUIPMENT:RF IMPEDANCE ANALYZER YHP4191A

• All specifications are subject to change without notice.

TYPICAL ELECTRICAL CHARACTERISTICS
Z, X, R vs. FREQUENCY CHARACTERISTICS
HF70ACC453215

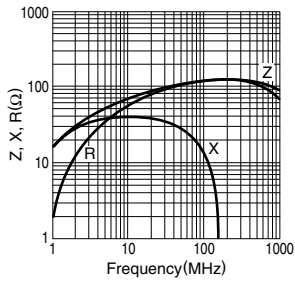

HF50ACC453215

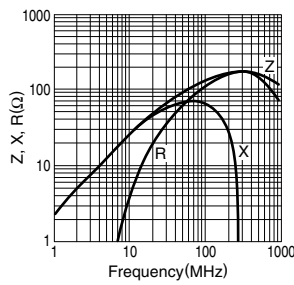

HF30ACC453215

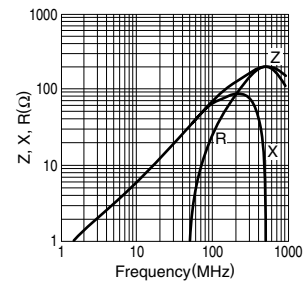

• TEST EQUIPMENT:RF IMPEDANCE ANALYZER YHP4191A

PACKAGING STYLES
201209 TO 322513 TYPES
REEL DIMENSIONS

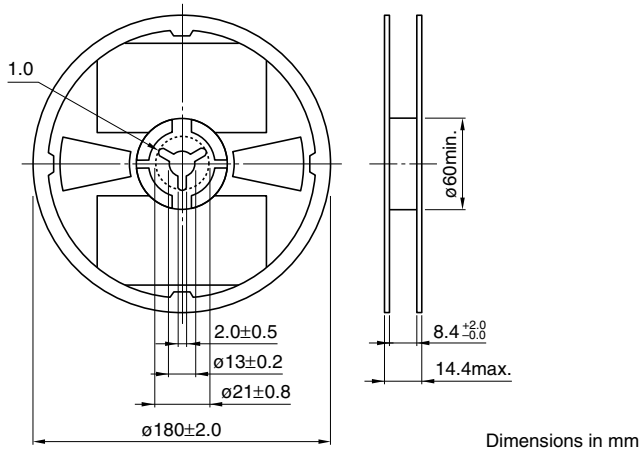

453215 TYPE
REEL DIMENSIONS

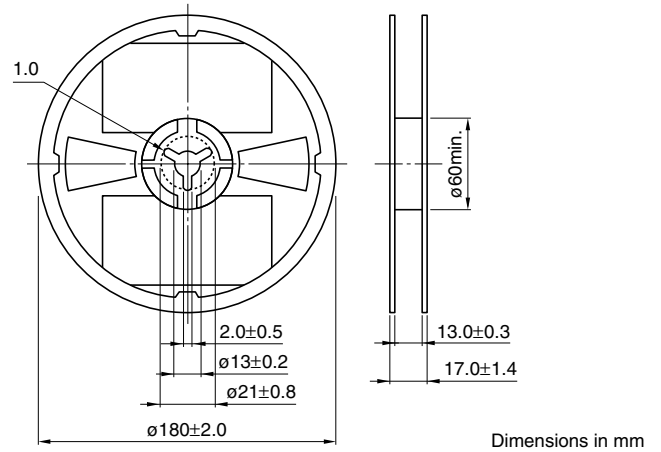

TAPE DIMENSIONS

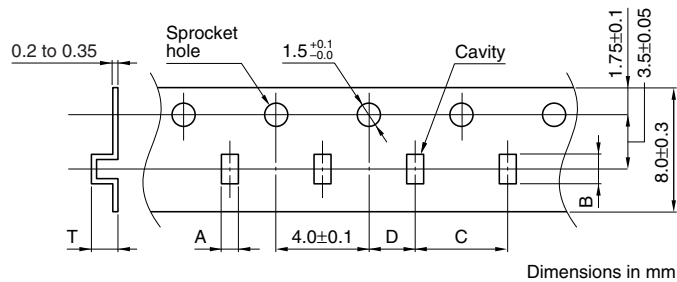

Type	A	B	C	D	T
201209	1.4±0.1	2.25±0.1	4.0±0.1	2.0±0.05	1.25max.
321611	1.75±0.1	3.45±0.1	4.0±0.1	2.0±0.05	1.4max.
322513	2.6±0.1	3.45±0.1	4.0±0.1	2.0±0.05	1.6max.

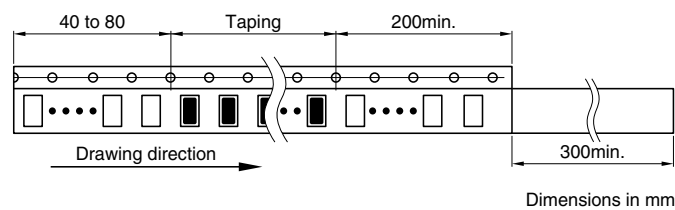

TAPE DIMENSIONS

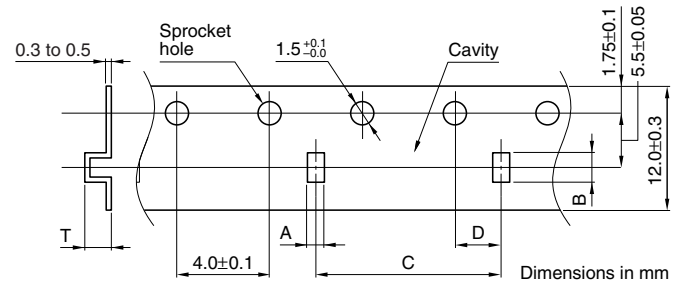

Type	A	B	C	D	T
453215	3.37±0.1	4.75±0.1	8.0±0.1	2.0±0.05	1.8max.

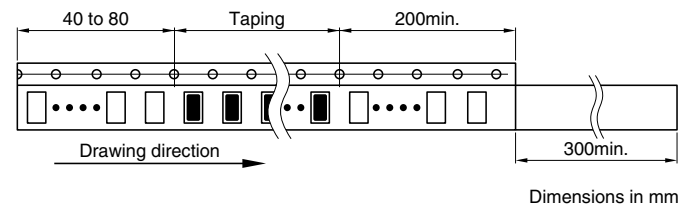

• All specifications are subject to change without notice.

X-ON Electronics

Largest Supplier of Electrical and Electronic Components

Click to view similar products for [Ferrite Beads](#) category:

Click to view products by [TDK](#) manufacturer:

Other Similar products are found below :

[2943778301](#) [BMB1J0120BN3JIT](#) [82350120560](#) [0261014605](#) [2643066902](#) [3061000011](#) [2673045901](#) [2643083601](#) [2643074901](#) [4361142521](#)
[4078078621](#) [4078044821](#) [4078033621](#) [CZB2BFTTE121P](#) [BMB2A0120AN2](#) [BMB1J0200BN3JIT](#) [EMI0805R-220](#) [74279250](#) [7427924](#)
[CZB1JGTTD202P](#) [MAF0603GWY551AT000](#) [MAF1005GWZ102AT000](#) [BLM18HE152SH1D](#) [2944778302](#) [BLM02PX600SN1D](#) [SMB2.5-1](#)
[EMI1206R-600](#) [BLM02KX180SN1D](#) [BLM02BC100SN1D](#) [BLM02KX100SN1D](#) [BLM02BB101SN1D](#) [BLM02BC220SN1D](#)
[BLE32PN260SH1L](#) [BLE32PN260SN1L](#) [BLE32PN260SZ1L](#) [74275013](#) [7427503](#) [BLM18HE601SH1D](#) [BLM15BD152SN1D](#)
[BLM15BD152SZ1D](#) [BLE18PS080SZ1D](#) [BLM21PG221BH1D](#) [WLBD1005HCU330TL](#) [BLM21AG471BH1D](#) [BLE18PS080BH1D](#)
[BLM21AG331BH1D](#) [BLM21PG300BH1D](#) [BLM21PG600BH1D](#) [BLM03HB401SZ1D](#) [BLM03HB401SN1D](#)