

ZWQ130/A

SPECIFICATIONS (CONVECTION COOLING)

A191-01-01/A-D

MODEL			ZWQ130-5223/A				ZWQ130-5225/A				
ITEMS			V1	V2	V3	V4	V1	V2	V3	V4	
1	Nominal Output Voltage	V	+5	+12	-12	+3.3	+5	+12	-12	+5	
2	Minimum Output Current (Convection) (*1)	A	1.5	0	0	0	1.5	0	0	0	
3	Minimum Output Current (Peak Applica(*1)	A	2.1	0	0	0	2.1	0	0	0	
4	Maximum Output Current	A	15.0	4.0	4.0	10.0	15.0	4.0	4.0	10.0	
5	Total Allowable Output Power (*2)	W	130								
6	Maximum Peak Output Current (*3)	A	19.0	5.0	5.0	12.0	19.0	5.0	5.0	12.0	
7	Total Allowable Peak Output Power (*2)	W	149.6				170				
8	Efficiency (Typ) (*4)	%	72								
9	Input Voltage Range (*5)	-	85 - 265VAC (47 - 63Hz) or 120 - 370VDC								
10	Input Current (100/200VAC) (Typ) (*4)	A	2.0/1.0								
11	Inrush Current (Typ) (*6)	-	14A at 100VAC, 28A at 200VAC, Ta=25°C, Cold Start								
12	PFHC	-	Designed to meet IEC61000-3-2								
13	Power Factor (100/200VAC) (Typ) (*4)	-	0.99 / 0.93								
14	Output Voltage Range	V	5.0-5.25	+12/+15	-12/-15	2.0-3.63	5.0-5.25	+12/+15	-12/-15	2.0-5.25	
15	Output Voltage Accuracy	-	-	±5%	±5%	-	-	±5%	±5%	-	
16	Maximum Ripple & Noise(*7)	0°C ≤ Ta < +50°C	mV	120	150	150	120	120	150	150	120
		-10 ≤ Ta < 0°C	mV	160	180	180	160	160	180	180	160
17	Maximum Line Regulation (*7,8)	mV	20	48	48	20	20	48	48	20	
18	Maximum Load Regulation (*7,9)	mV	100	300	300	100	100	300	300	100	
19	Temperature Coefficient	-	Less than 0.02% /°C								
20	Over Current Protection (*10)	-	More than 152W of Total Output Power				More than 173W of Total Output Power				
21	Over Voltage Protection (*11)	V	5.7 - 7.0	16.5 - 22.5	-22.5 - -16.5	3.79 - 4.95	5.7 - 7.0	16.5 - 22.5	-22.5 - -16.5	5.7 - 7.0	
22	Hold-Up Time (Typ) (*12)	-	20 ms								
23	Leakage Current (*13)	-	0.75mA MAX,0.2mA(Typ) at 100VAC / 0.44mA(Typ) at 230VAC								
24	Remote ON/OFF Control	-	-								
25	Parallel Operation	-	-								
26	Series Operation	-	-								
27	Operating Temperature (*14)	-	-10 - +50°C (-10 - +30°C : 100%, +50°C : 50%)								
28	Operating Humidity	-	30 - 90%RH (No Dewdrop)								
29	Storage Temperature	-	-30 - +85°C								
30	Storage Humidity	-	10 - 95%RH (No Dewdrop)								
31	Cooling	-	Convection Cooling								
32	Withstand Voltage		Input - FG : 2kVAC(20mA), Input - Output : 3kVAC (20mA) Output - FG : 500VAC(100mA), for 1min.								
33	Isolation Resistance	-	More than 100MΩ at 25°C and 70%RH Output - FG : 500VDC								
34	Vibration	-	At no operating, 10-55Hz (Sweep for 1min) 19.6 m/s ² Constant, X, Y, Z 1h each.								
35	Shock (In package)	-	Less than 196.1 m/s ²								
36	Safety (*15)	-	Approved by UL60950-1, CSA C22.2 No.60950-1, EN60950-1 Designed to meet DENAN								
37	EMI	-	Designed to meet EN55011/EN55022-B, FCC-ClassB, VCCI-B								
38	Immunity (*16)	-	Designed to meet EN61000-4-2, -3, -4, -5, -6, -8, -11								
39	Weight (Typ)	-	1000g								
40	Size (WxHxD)	mm	108.5 x 44.5 x 250 (Refer to Outline Drawing)								

*Read instruction manual carefully, before using the power supply unit.

=NOTES=

- *1. For V2, V3, V4 stability, require minimum output current of V1.
- *2. Allowable output power is changed according to V4 voltage refer to derating table (A191-01-05/A-).
- *3. Operating period at peak current is less than 10sec. (Duty ≤ 0.35)
- *4. At 100/200VAC, Ta=25°C and total allowable output power.
- *5. For cases where conformance to various safety specs (UL, CSA, EN) are required, to be described as 100 - 240VAC(50/60Hz).
- *6. Not applicable for the inrush current to Noise Filter for less than 0.2ms.
- *7. Refer to output measuring (A191-01-07/A-) for line & load regulation and ripple voltage.
- *8. 85 - 265VAC, constant load.
- *9. Minimum load - Full load, constant input voltage.
- *10. Constant current limit with automatic recovery. Refer to test data (A191-53-01-).
- Not operate at over load or dead short condition for more than 30 seconds.
- *11. OVP circuit will shut down all outputs, manual reset (Line recycle).
- *12. At 100/200VAC, nominal output voltage and total allowable output power.
- *13. Measured by the each method of UL, CSA, EN and DENAN (at 60Hz), Ta=25°C.
- *14. At standard mounting.
- Load (%) is percent of total allowable output power or each maximum output current, whichever is greater.
For other mountings, refer to derating curve (A191-01-05/A-).
- *15. As for DENAN, built to meet at 100VAC.
- *16. Refer to test data(A191-58-01-).

ZWQ130/A**SPECIFICATIONS (FORCED AIR COOLING)**

A191-01-02/A-D

ITEMS	MODEL	ZWQ130-5223/A				ZWQ130-5225/A				
		V1	V2	V3	V4	V1	V2	V3	V4	
1	Nominal Output Voltage	V	+5	+12	-12	+3.3	+5	+12	-12	+5
2	Minimum Output Current (*1)	A	2.1	0	0	0	2.1	0	0	0
3	Maximum Output Current	A	19.0	5.0	5.0	12.0	19.0	5.0	5.0	12.0
4	Total Allowable Output Power (*2)	W	149.6				170			
5	Input Current (100/200VAC) (Typ) (*3)	A	2.6/1.3							
6	Operating Temperature (*4)	-	-10 ~ +60°C (-10 ~ +40°C : 100%, +60°C : 50%)							
7	Cooling (*5)	-	Forced Air Cooling							

*Read instruction manual carefully, before using the power supply unit.

=NOTES=

*For other items, refer to convection cooling specifications (A191-01-01/A-).

*1. For V2, V3, V4 stability, require minimum output current of V1.

When it is using under condition of forced air cooling, V1 minimum output current is same as convection cooling.

*2. Allowable output power is changed according to V4 voltage, refer to derating table (A191-01-06/A-).

*3. At 100/200VAC, Ta=25°C total allowable output power.

*4. At standard mounting.

- Load (%) is percent of total allowable output power or each maximum output current, whichever is greater.

For other mountings, refer to derating curve (A191-01-06/A-).

*5. Air flow $\geq 0.85\text{m}^3/\text{min}$ (30cfm)

ZWQ130/A

SPECIFICATIONS (CONVECTION COOLING)

A191-01-03/A-C

ITEMS		MODEL	ZWQ130-5222/A				ZWQ130-5224/A				
			V1	V2	V3	V4	V1	V2	V3	V4	
1	Nominal Output Voltage	V	+5	+12	-12	+12	+5	+12	-12	+24	
2	Minimum Output Current (Convection) (*1)	A	1.5	0	0	0	1.5	0	0	0	
3	Minimum Output Current (Peak Applicati (*1)	A	2.1	0	0	0	2.1	0	0	0	
4	Maximum Output Current	A	15.0	4.0	4.0	4.0	15.0	4.0	4.0	2.0	
5	Total Allowable Output Power	W	130								
6	Maximum Peak Output Current (*2)	A	19.0	5.0	5.0	5.0	19.0	5.0	5.0	2.5	
7	Total Allowable Peak Output Power	W	170								
8	Efficiency (Typ) (*3)	%	72								
9	Input Voltage Range (*4)	-	85 - 265VAC (47 - 63Hz) or 120 - 370VDC								
10	Input Current (100/200VAC) (Typ) (*3)	A	2.0 / 1.0								
11	Inrush Current (Typ) (*5)	-	14A at 100VAC, 28A at 200VAC, Ta=25°C, Cold Start								
12	PFHC	-	Designed to meet IEC61000-3-2								
13	Power Factor (100/200VAC) (Typ) (*3)	-	0.99 / 0.93								
14	Output Voltage Range	-	5.0-5.25	+12/+15	-12/-15	11.4-12.6	5.0-5.25	+12/+15	-12/-15	22.8-25.2	
15	Output Voltage Accuracy	-	-	±5%	±5%	-	-	±5%	±5%	-	
16	Maximum Ripple & Noise (*6)	0°C ≤ Ta ≤ +50°C	mV	120	150	150	150	120	150	150	200
		-10 ≤ Ta < 0°C	mV	160	180	180	180	160	180	180	200
17	Maximum Line Regulation (*6,7)	mV	20	48	48	48	20	48	48	96	
18	Maximum Load Regulation (*6,8)	mV	100	300	300	300	100	300	300	400	
19	Temperature Coefficient	-	Less than 0.02% / °C								
20	Over Current Protection (*9)	-	More than 173W of Total Output Power								
21	Over Voltage Protection (*10)	V	5.7 - 7.0	16.5 - 22.5	-22.5 - -16.5	13.8 - 16.2	5.7 - 7.0	16.5 - 22.5	-22.5 - -16.5	27.6 - 32.4	
22	Hold-Up Time (Typ) (*11)	-	20 ms								
23	Leakage Current (*12)	-	0.75mA MAX,0.2mA(Typ) at 100VAC / 0.44mA(Typ) at 230VAC								
24	Remote ON/OFF Control	-	-								
25	Parallel Operation	-	-								
26	Series Operation	-	-								
27	Operating Temperature (*13)	-	-10 - +50°C (-10 - +30°C : 100%, +50°C : 50%)								
28	Operating Humidity	-	30 - 90%RH (No Dewdrop)								
29	Storage Temperature	-	-30 - +85°C								
30	Storage Humidity	-	10 - 95%RH (No Dewdrop)								
31	Cooling	-	Convection Cooling								
32	Withstand Voltage	-	Input - FG:2kVAC(20mA), Input - Output:3kVAC (20mA) Output - FG:500VAC(100mA), for 1min.								
33	Isolation Resistance	-	More than 100MΩ at 25°C and 70%RH Output - FG:500VDC								
34	Vibration	-	At no operating, 10-55Hz (Sweep for 1min) 19.6 m/s ² Constant, X, Y, Z 1h each.								
35	Shock (In package)	-	Less than 196.1 m/s ²								
36	Safety (*14)	-	Approved by UL60950-1, CSA C22.2 No.60950-1, EN60950-1 Designed to meet DENAN								
37	EMI	-	Designed to meet EN55011/EN55022-B, FCC-ClassB, VCCI-B								
38	Immunity (*15)	-	Designed to meet EN61000-4-2, -3, -4, -5, -6, -8, -11								
39	Weight (Typ)	-	1000g								
40	Size (WxHxD)	mm	108.5 x 44.5 x 250 (Refer to Outline Drawing)								

*Read instruction manual carefully, before using the power supply unit.

=NOTES=

- *1. For V2, V3,V4 stability, require minimum output current of V1.
- *2. Operating period at peak current is less than 10sec. (Duty≤0.35)
- *3. At 100/200VAC, Ta=25°C and total allowable output power.
- *4. For cases where conformance to various safety specs (UL, CSA, EN) are required, to be described as 100 - 240VAC(50/60Hz).
- *5. Not applicable for the inrush current to Noise Filter for less than 0.2ms.
- *6. Refer to output measuring (A191-01-07/A-_) for line & load regulation and ripple voltage.
- *7. 85 - 265VAC , constant load.
- *8. Minimum load - Full load, constant input voltage.
- *9. Constant current limit with automatic recovery. Refer to test data (A191-53-01_).
Not operate at over load or dead short condition for more than 30 seconds.
- *10. OVP circuit will shut down all outputs, manual reset (Line recycle).
- *11. At 100/200VAC, nominal output voltage and total allowable output power.
- *12. Measured by the each method of UL, CSA, EN and DENAN (at 60Hz), Ta=25°C.
- *13. At standard mounting
- Load (%) is percent of total allowable output power or each maximum output current, whichever is greater.
For other mountings, refer to derating curve (A191-01-05/A-_).
- *14. As for DENAN, designed to meet at 100VAC.
- *15. Refer to test data(A191-58-01_).

ZWQ130/A**SPECIFICATIONS (FORCED AIR COOLING)**

A191-01-04/A-C

ITEMS	MODEL	ZWQ130-5222/A				ZWQ130-5224/A				
		V1	V2	V3	V4	V1	V2	V3	V4	
1	Nominal Output Voltage	V	+5	+12	-12	+12	+5	+12	-12	+24
2	Minimum Output Current (*1)	A	2.1	0	0	0	2.1	0	0	0
3	Maximum Output Current	A	19.0	5.0	5.0	5.0	19.0	5.0	5.0	2.5
4	Total Allowable Output Power	W	170							
5	Input Current (100/200VAC) (Typ) (*2)	A	2.6 / 1.3							
6	Operating Temperature (*3)	-	-10 ~ +60°C (-10 ~ +40°C : 100%, +60°C : 50%)							
7	Cooling (*4)	-	Forced Air Cooling							

*Read instruction manual carefully, before using the power supply unit.

=NOTES=

*For other items, refer to convection cooling specifications (A191-01-03/A-).

*1. For V2, V3, V4 stability, require minimum output current of V1.

When it is using under condition of forced air cooling, V1 minimum output current is same as convection cooling.

*2. At 100/200VAC, Ta=25°C total allowable output power.

*3. At standard mounting.

- Load (%) is percent of total allowable output power or each maximum output current, whichever is greater.

For other mountings, refer to derating curve (A191-01-06/A-).

*4. Air flow $\geq 0.85\text{m}^3/\text{min}$ (30cfm)

ZWQ130/A

OUTPUT DERATING (CONVECTION COOLING)

A191-01-05/A

Ta(°C)	LOAD (%)		
	MOUNTING A	MOUNTING B,C,D	MOUNTING E
-10 ~+15	100	100	100
20	100	100	87
25	100	87	75
30	100	75	62
35	87	62	50
40	75	50	
45	62		
50	50		

Allowable output power

5225/A

A	B	C
5V	170W	130W
3V	146W	130W
2V	134W	130W

5223/A

A	B	C
3.3V	149.6W	130W
3V	146W	130W
2V	134W	130W

A : V4 setting voltage
 B : Total Allowable Peak Output Power
 C : Total Allowable Output Power

* The period of peak current at Convection Cooling is limited less than 10sec. (Duty ≤ 0.35)
 For peak current application, refer to note (A191-01-07/A_).

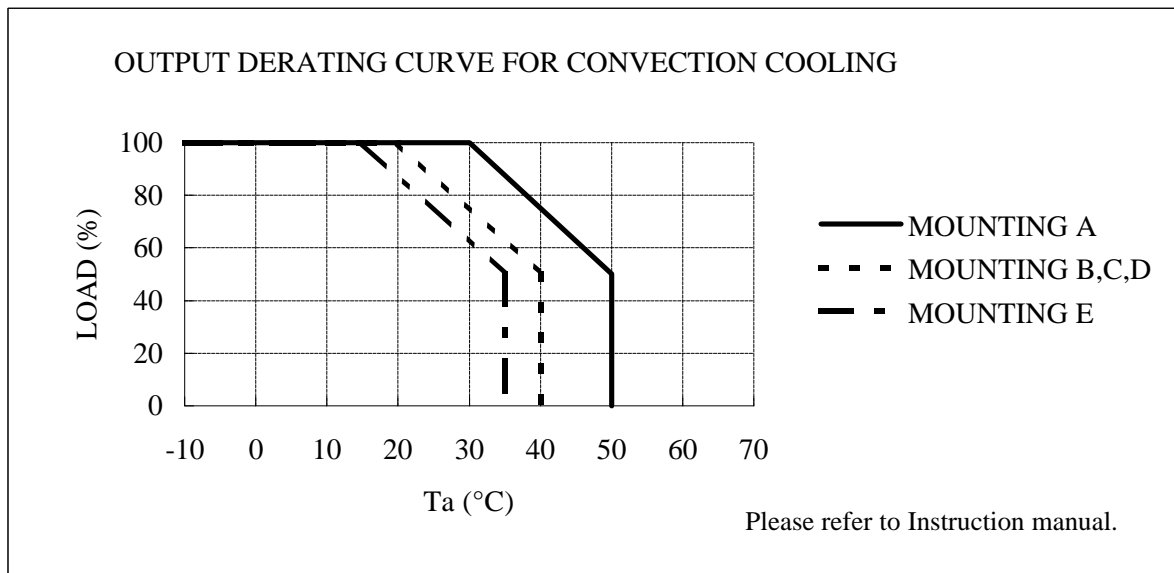

* Load (%) is percent of total allowable output power or each maximum output current, whichever is greater.

- MOUNTING A
 MOUNTING B
 MOUNTING C
 MOUNTING D
 MOUNTING E
 PROHIBIT

(STANDARD MOUNTING)

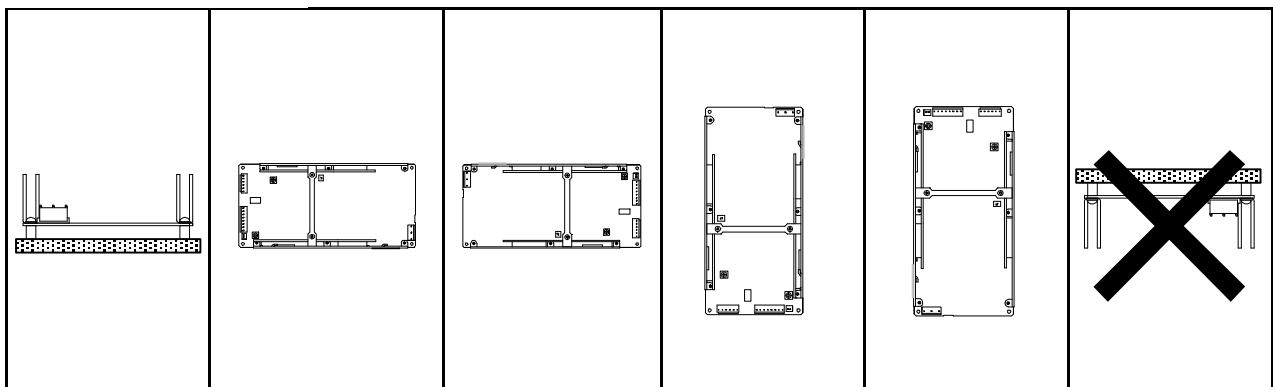

OUTPUT DERATING (FORCED AIR COOLING)

A191-01-06/A-A

Allowable output power

Ta(°C)	LOAD (%)
	MOUNTING A,B,C,D,E
-10 ~+30	100
35	100
40	100
45	87
50	75
55	62
60	50

5225/A	
A	B
5V	170W
3V	146W
2V	134W

5223/A	
A	B
3.3V	149.6W
3V	146W
2V	134W

A : V4 setting voltage

B : Total Allowable Output Power

* Air flow $\geq 0.85\text{m}^3/\text{min}(30\text{cfm})$
Air must flow through component side.

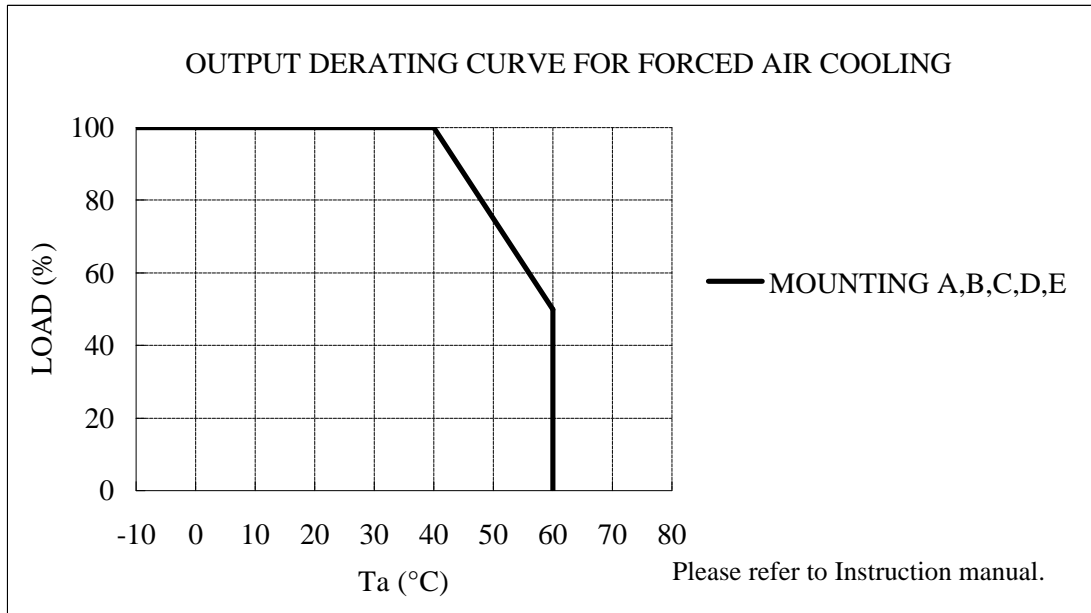

* Load (%) is percent of total allowable output power or each maximum output current, whichever is greater.

MOUNTING A MOUNTING B MOUNTING C MOUNTING D MOUNTING E PROHIBIT

(STANDARD MOUNTING)

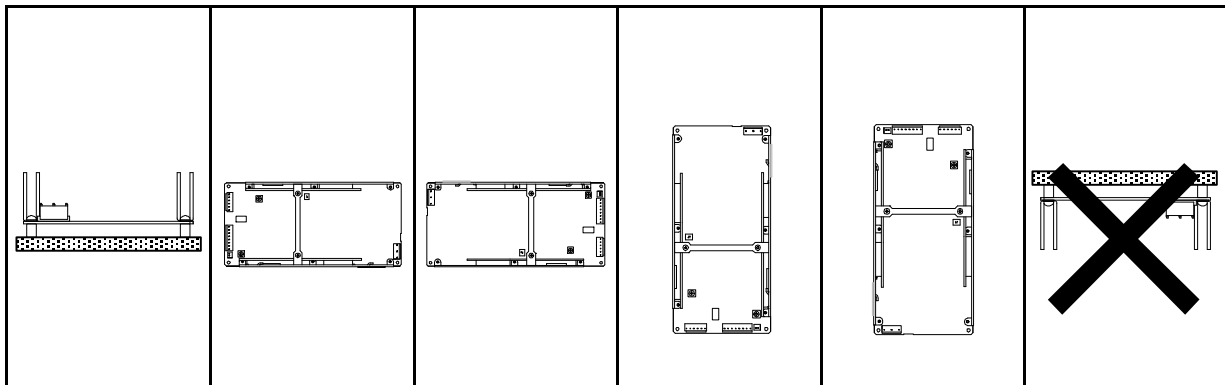

NOTE

A191-01-07/A

Output Measuring

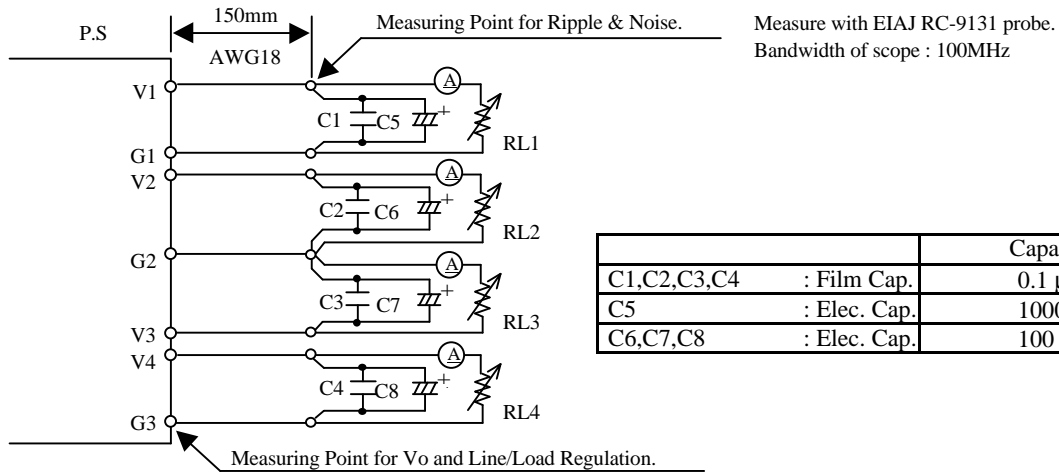

Capacitance	
C1,C2,C3,C4	: Film Cap. 0.1 μF
C5	: Elec. Cap. 1000 μF
C6,C7,C8	: Elec. Cap. 100 μF

Peak Output Current (Convection Cooling)

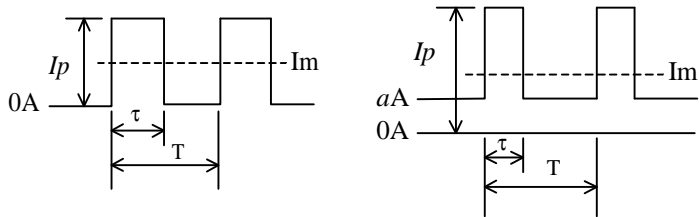

$$I_{av} \geq I_m = \frac{I_p \times t}{T}$$

$$I_{av} \geq I_m = \frac{(I_p - a) \times t}{T} + a$$

- Ip : Peak output current (A)
- Iav : Average output current (A)
(Maximum output current (Convection) in Spec.)
- Im : Average output current (A)
- t : Pulse width of peak output current (sec)
(Operating time at peak output)
- T : Period (sec) : more than 10ms

* The period of peak current at Convection Cooling is limited less than 10sec.. (Duty ≤ 0.35)
* Take V1 minimum output current more than 2.1A.

X-ON Electronics

Largest Supplier of Electrical and Electronic Components

Click to view similar products for [Modular Power Supplies](#) category:

Click to view products by [TDK-Lambda](#) manufacturer:

Other Similar products are found below :

[73-147-000](#) [73-270-000](#) [73-316-4020](#) [73-317-0005](#) [73-495-0333](#) [73-961-4086-G2](#) [GLD150-48-103-G](#) [PS3E-B12F](#) [PS3E-E12F](#) [AS300-MLF](#)
[OVS-12E](#) [OVS-12F](#) [OVS-12J](#) [OVS-15F](#) [OVS-15J](#) [IVS13Q2Q1F4LL030ANJCUNR32](#) [LB115S48KH](#) [FP2-PSA1](#) [PS3E-F12F](#) [IMP4-3O1-](#)
[2J1-05-B-662](#) [UPS40-3003](#) [LB240S48KH](#) [LMM409](#) [CHASSIS](#) [ADNB008-48-1PM-C](#) [ADNB017-24-1PM-C](#) [ADNB040-24-1PM-C](#)
[VAS003ZG](#) [ADNB050-12-1PM-C](#) [ADNB040-15-1PM-C](#) [ADNB034-12-1PM-C](#) [73-166-000](#) [73-271-000](#) [73-961-4085-G2](#) [73-962-0001](#)
[OVS-15G](#) [1-155777G](#) [OVS-24F](#) [OVS-5F](#) [73-551-5086](#) [73-554-4047](#) [73-670-0001I](#) [73-713-001](#) [73-769-003](#) [73-954-0001C-G2](#) [73-951-](#)
[0001S-G2](#) [73-560-434](#) [73-180-0001I](#) [73-554-4045](#) [73-956-0001S-G2](#) [73-963-0048-G2](#)