

# RL78/G13

16

User's Manual: Hardware

## 16-Bit Single-Chip Microcontrollers

All information contained in these materials, including products and product specifications, represents information on the product at the time of publication and is subject to change by Renesas Electronics Corp. without notice. Please review the latest information published by Renesas Electronics Corp. through various means, including the Renesas Electronics Corp. website (<http://www.renesas.com>).

## Notice

1. All information included in this document is current as of the date this document is issued. Such information, however, is subject to change without any prior notice. Before purchasing or using any Renesas Electronics products listed herein, please confirm the latest product information with a Renesas Electronics sales office. Also, please pay regular and careful attention to additional and different information to be disclosed by Renesas Electronics such as that disclosed through our website.
2. Renesas Electronics does not assume any liability for infringement of patents, copyrights, or other intellectual property rights of third parties by or arising from the use of Renesas Electronics products or technical information described in this document. No license, express, implied or otherwise, is granted hereby under any patents, copyrights or other intellectual property rights of Renesas Electronics or others.
3. You should not alter, modify, copy, or otherwise misappropriate any Renesas Electronics product, whether in whole or in part.
4. Descriptions of circuits, software and other related information in this document are provided only to illustrate the operation of semiconductor products and application examples. You are fully responsible for the incorporation of these circuits, software, and information in the design of your equipment. Renesas Electronics assumes no responsibility for any losses incurred by you or third parties arising from the use of these circuits, software, or information.
5. When exporting the products or technology described in this document, you should comply with the applicable export control laws and regulations and follow the procedures required by such laws and regulations. You should not use Renesas Electronics products or the technology described in this document for any purpose relating to military applications or use by the military, including but not limited to the development of weapons of mass destruction. Renesas Electronics products and technology may not be used for or incorporated into any products or systems whose manufacture, use, or sale is prohibited under any applicable domestic or foreign laws or regulations.
6. Renesas Electronics has used reasonable care in preparing the information included in this document, but Renesas Electronics does not warrant that such information is error free. Renesas Electronics assumes no liability whatsoever for any damages incurred by you resulting from errors in or omissions from the information included herein.
7. Renesas Electronics products are classified according to the following three quality grades: “Standard”, “High Quality”, and “Specific”. The recommended applications for each Renesas Electronics product depends on the product’s quality grade, as indicated below. You must check the quality grade of each Renesas Electronics product before using it in a particular application. You may not use any Renesas Electronics product for any application categorized as “Specific” without the prior written consent of Renesas Electronics. Further, you may not use any Renesas Electronics product for any application for which it is not intended without the prior written consent of Renesas Electronics. Renesas Electronics shall not be in any way liable for any damages or losses incurred by you or third parties arising from the use of any Renesas Electronics product for an application categorized as “Specific” or for which the product is not intended where you have failed to obtain the prior written consent of Renesas Electronics. The quality grade of each Renesas Electronics product is “Standard” unless otherwise expressly specified in a Renesas Electronics data sheets or data books, etc.
  - “Standard”: Computers; office equipment; communications equipment; test and measurement equipment; audio and visual equipment; home electronic appliances; machine tools; personal electronic equipment; and industrial robots.
  - “High Quality”: Transportation equipment (automobiles, trains, ships, etc.); traffic control systems; anti-disaster systems; anti-crime systems; safety equipment; and medical equipment not specifically designed for life support.
  - “Specific”: Aircraft; aerospace equipment; submersible repeaters; nuclear reactor control systems; medical equipment or systems for life support (e.g. artificial life support devices or systems), surgical implantations, or healthcare intervention (e.g. excision, etc.), and any other applications or purposes that pose a direct threat to human life.
8. You should use the Renesas Electronics products described in this document within the range specified by Renesas Electronics, especially with respect to the maximum rating, operating supply voltage range, movement power voltage range, heat radiation characteristics, installation and other product characteristics. Renesas Electronics shall have no liability for malfunctions or damages arising out of the use of Renesas Electronics products beyond such specified ranges.
9. Although Renesas Electronics endeavors to improve the quality and reliability of its products, semiconductor products have specific characteristics such as the occurrence of failure at a certain rate and malfunctions under certain use conditions. Further, Renesas Electronics products are not subject to radiation resistance design. Please be sure to implement safety measures to guard them against the possibility of physical injury, and injury or damage caused by fire in the event of the failure of a Renesas Electronics product, such as safety design for hardware and software including but not limited to redundancy, fire control and malfunction prevention, appropriate treatment for aging degradation or any other appropriate measures. Because the evaluation of microcomputer software alone is very difficult, please evaluate the safety of the final products or system manufactured by you.
10. Please contact a Renesas Electronics sales office for details as to environmental matters such as the environmental compatibility of each Renesas Electronics product. Please use Renesas Electronics products in compliance with all applicable laws and regulations that regulate the inclusion or use of controlled substances, including without limitation, the EU RoHS Directive. Renesas Electronics assumes no liability for damages or losses occurring as a result of your noncompliance with applicable laws and regulations.
11. This document may not be reproduced or duplicated, in any form, in whole or in part, without prior written consent of Renesas Electronics.
12. Please contact a Renesas Electronics sales office if you have any questions regarding the information contained in this document or Renesas Electronics products, or if you have any other inquiries.

(Note 1) “Renesas Electronics” as used in this document means Renesas Electronics Corporation and also includes its majority-owned subsidiaries.

(Note 2) “Renesas Electronics product(s)” means any product developed or manufactured by or for Renesas Electronics.

## NOTES FOR CMOS DEVICES

- (1) **VOLTAGE APPLICATION WAVEFORM AT INPUT PIN:** Waveform distortion due to input noise or a reflected wave may cause malfunction. If the input of the CMOS device stays in the area between VIL (MAX) and VIH (MIN) due to noise, etc., the device may malfunction. Take care to prevent chattering noise from entering the device when the input level is fixed, and also in the transition period when the input level passes through the area between VIL (MAX) and VIH (MIN).
- (2) **HANDLING OF UNUSED INPUT PINS:** Unconnected CMOS device inputs can be cause of malfunction. If an input pin is unconnected, it is possible that an internal input level may be generated due to noise, etc., causing malfunction. CMOS devices behave differently than Bipolar or NMOS devices. Input levels of CMOS devices must be fixed high or low by using pull-up or pull-down circuitry. Each unused pin should be connected to VDD or GND via a resistor if there is a possibility that it will be an output pin. All handling related to unused pins must be judged separately for each device and according to related specifications governing the device.
- (3) **PRECAUTION AGAINST ESD:** A strong electric field, when exposed to a MOS device, can cause destruction of the gate oxide and ultimately degrade the device operation. Steps must be taken to stop generation of static electricity as much as possible, and quickly dissipate it when it has occurred. Environmental control must be adequate. When it is dry, a humidifier should be used. It is recommended to avoid using insulators that easily build up static electricity. Semiconductor devices must be stored and transported in an anti-static container, static shielding bag or conductive material. All test and measurement tools including work benches and floors should be grounded. The operator should be grounded using a wrist strap. Semiconductor devices must not be touched with bare hands. Similar precautions need to be taken for PW boards with mounted semiconductor devices.
- (4) **STATUS BEFORE INITIALIZATION:** Power-on does not necessarily define the initial status of a MOS device. Immediately after the power source is turned ON, devices with reset functions have not yet been initialized. Hence, power-on does not guarantee output pin levels, I/O settings or contents of registers. A device is not initialized until the reset signal is received. A reset operation must be executed immediately after power-on for devices with reset functions.
- (5) **POWER ON/OFF SEQUENCE:** In the case of a device that uses different power supplies for the internal operation and external interface, as a rule, switch on the external power supply after switching on the internal power supply. When switching the power supply off, as a rule, switch off the external power supply and then the internal power supply. Use of the reverse power on/off sequences may result in the application of an overvoltage to the internal elements of the device, causing malfunction and degradation of internal elements due to the passage of an abnormal current. The correct power on/off sequence must be judged separately for each device and according to related specifications governing the device.
- (6) **INPUT OF SIGNAL DURING POWER OFF STATE :** Do not input signals or an I/O pull-up power supply while the device is not powered. The current injection that results from input of such a signal or I/O pull-up power supply may cause malfunction and the abnormal current that passes in the device at this time may cause degradation of internal elements. Input of signals during the power off state must be judged separately for each device and according to related specifications governing the device.

# How to Use This Manual

## Readers

This manual is intended for user engineers who wish to understand the functions of the RL78/G13 and design and develop application systems and programs for these devices. The target products are as follows.

- 20-pin: R5F1006x (x = A, C, D, E)  
R5F1016x (x = A, C, D, E)
- 24-pin: R5F1007x (x = A, C, D, E)  
R5F1017x (x = A, C, D, E)
- 25-pin: R5F1008x (x = A, C, D, E)  
R5F1018x (x = A, C, D, E)
- 30-pin: R5F100Ax (x = A, C, D, E, F, G)  
R5F101Ax (x = A, C, D, E, F, G)
- 32-pin: R5F100Bx (x = A, C, D, E, F, G)  
R5F101Bx (x = A, C, D, E, F, G)
- 36-pin: R5F100Cx (x = A, C, D, E, F, G)  
R5F101Cx (x = A, C, D, E, F, G)
- 40-pin: R5F100Ex (x = A, C, D, E, F, G, H)  
R5F101Ex (x = A, C, D, E, F, G, H)
- 44-pin: R5F100Fx (x = A, C, D, E, F, G, H, J, K, L)  
R5F101Fx (x = A, C, D, E, F, G, H, J, K, L)
- 48-pin: R5F100Gx (x = A, C, D, E, F, G, H, J, K, L)  
R5F101Gx (x = A, C, D, E, F, G, H, J, K, L)
- 52-pin: R5F100Jx (x = C, D, E, F, G, H, J, K, L)  
R5F101Jx (x = C, D, E, F, G, H, J, K, L)
- 64-pin: R5F100Lx (x = C, D, E, F, G, H, J, K, L)  
R5F101Lx (x = C, D, E, F, G, H, J, K, L)
- 80-pin: R5F100Mx (x = F, G, H, J, K, L)  
R5F101Mx (x = F, G, H, J, K, L)
- 100-pin: R5F100Px (x = F, G, H, J, K, L)  
R5F101Px (x = F, G, H, J, K, L)
- 128-pin: R5F100Sx (x = H, J, K, L)  
R5F101Sx (x = H, J, K, L)

## Purpose

This manual is intended to give users an understanding of the functions described in the **Organization** below.

## Organization

The RL78/G13 manual is separated into two parts: this manual and the instructions edition (common to the RL78 Microcontroller).

<p style="text-align: center;"><b>RL78/G13</b> <b>User's Manual</b> <b>(This Manual)</b></p>
--

<p style="text-align: center;"><b>RL78 Microcontroller</b> <b>User's Manual</b> <b>Instructions</b></p>
---

- Pin functions
- Internal block functions
- Interrupts
- Other on-chip peripheral functions
- Electrical specifications
- CPU functions
- Instruction set
- Explanation of each instruction

**How to Read This Manual** It is assumed that the readers of this manual have general knowledge of electrical engineering, logic circuits, and microcontrollers.

- To gain a general understanding of functions:
  - Read this manual in the order of the **CONTENTS**. The mark “<R>” shows major revised points. The revised points can be easily searched by copying an “<R>” in the PDF file and specifying it in the “Find what:” field.
- How to interpret the register format:
  - For a bit number enclosed in angle brackets, the bit name is defined as a reserved word in the assembler, and is defined as an sfr variable using the #pragma sfr directive in the compiler.
- To know details of the RL78 Microcontroller instructions:
  - Refer to the separate document **RL78 Microcontroller Instructions User’s Manual (R01US0015E)**.

**Conventions**

Data significance: Higher digits on the left and lower digits on the right  
 Active low representations:  $\overline{xxx}$  (overscore over pin and signal name)  
**Note:** Footnote for item marked with **Note** in the text  
**Caution:** Information requiring particular attention  
**Remark:** Supplementary information  
 Numerical representations: Binary      ...xxxx or xxxxB  
   Decimal      ...xxxx  
   Hexadecimal   ...xxxxH

**Related Documents**

The related documents indicated in this publication may include preliminary versions. However, preliminary versions are not marked as such.

**Documents Related to Devices**

Document Name	Document No.
RL78/G13 User’s Manual Hardware	This manual
RL78 Microcontroller Instructions User’s Manual	R01US0015E

**Documents Related to Flash Memory Programming**

Document Name	Document No.
PG-FP5 Flash Memory Programmer User’s Manual	R20UT0008E

**Caution** The related documents listed above are subject to change without notice. Be sure to use the latest version of each document when designing.

## Other Documents

Document Name	Document No.
RENESAS MICROCOMPUTER GENERAL CATALOG	R01CS0001E
Semiconductor Device Mount Manual	<b>Note</b>
Quality Grades on NEC Semiconductor Devices	C11531E
NEC Semiconductor Device Reliability/Quality Control System	C10983E
Guide to Prevent Damage for Semiconductor Devices by Electrostatic Discharge (ESD)	C11892E

**Note** See the "Semiconductor Device Mount Manual" website (<http://www.renesas.com/prod/package/manual/index.html>).

**Caution** The related documents listed above are subject to change without notice. Be sure to use the latest version of each document when designing.

All trademarks and registered trademarks are the property of their respective owners.

EEPROM is a trademark of Renesas Electronics Corporation.

Windows, Windows NT and Windows XP are registered trademarks or trademarks of Microsoft Corporation in the United States and/or other countries.

PC/AT is a trademark of International Business Machines Corporation.

SuperFlash is a registered trademark of Silicon Storage Technology, Inc. in several countries including the United States and Japan.

Caution: This product uses SuperFlash® technology licensed from Silicon Storage Technology, Inc.
--

# CONTENTS

<b>CHAPTER 1 OUTLINE.....</b>	<b>1</b>
<b>1.1 Features.....</b>	<b>1</b>
<b>1.2 Ordering Information.....</b>	<b>3</b>
<b>1.3 Pin Configuration (Top View) .....</b>	<b>6</b>
1.3.1 20-pin products.....	6
1.3.2 24-pin products.....	7
1.3.3 25-pin products.....	8
1.3.4 30-pin products.....	9
1.3.5 32-pin products.....	10
1.3.6 36-pin products.....	11
1.3.7 40-pin products.....	12
1.3.8 44-pin products.....	13
1.3.9 48-pin products.....	14
1.3.10 52-pin products.....	16
1.3.11 64-pin products.....	17
1.3.12 80-pin products.....	19
1.3.13 100-pin products.....	20
1.3.14 128-pin products.....	22
<b>1.4 Pin Identification.....</b>	<b>23</b>
<b>1.5 Block Diagram .....</b>	<b>24</b>
1.5.1 20-pin products.....	24
1.5.2 24-pin products.....	25
1.5.3 25-pin products.....	26
1.5.4 30-pin products.....	27
1.5.5 32-pin products.....	28
1.5.6 36-pin products.....	29
1.5.7 40-pin products.....	30
1.5.8 44-pin products.....	31
1.5.9 48-pin products.....	32
1.5.10 52-pin products.....	33
1.5.11 64-pin products.....	34
1.5.12 80-pin products.....	35
1.5.13 100-pin products.....	36
1.5.14 128-pin products.....	37
<b>1.6 Outline of Functions.....</b>	<b>38</b>

<b>CHAPTER 2 PIN FUNCTIONS .....</b>	<b>44</b>
<b>2.1 Pin Function List .....</b>	<b>44</b>
2.1.1 20-pin products.....	45
2.1.2 24-pin products.....	46
2.1.3 25-pin products.....	47
2.1.4 30-pin products.....	48
2.1.5 32-pin products.....	50
2.1.6 36-pin products.....	52
2.1.7 40-pin products.....	54
2.1.8 44-pin products.....	56
2.1.9 48-pin products.....	58
2.1.10 52-pin products.....	60
2.1.11 64-pin products.....	62
2.1.12 80-pin products.....	64
2.1.13 100-pin products.....	67
2.1.14 128-pin products.....	70
2.1.15 Pins for each product (pins other than port pins).....	74
<b>2.2 Description of Pin Functions .....</b>	<b>80</b>
2.2.1 P00 to P07 (port 0) .....	80
2.2.2 P10 to P17 (port 1) .....	81
2.2.3 P20 to P27 (port 2) .....	82
2.2.4 P30 to P37 (port 3) .....	82
2.2.5 P40 to P47 (port 4) .....	83
2.2.6 P50 to P57 (port 5) .....	85
2.2.7 P60 to P67 (port 6) .....	85
2.2.8 P70 to P77 (port 7) .....	86
2.2.9 P80 to P87 (port 8) .....	87
2.2.10 P90 to P97 (port 9) .....	87
2.2.11 P100 to P106 (port 10) .....	87
2.2.12 P110 to P117 (port 11) .....	88
2.2.13 P120 to P127 (port 12) .....	88
2.2.14 P130, P137 (port 13) .....	89
2.2.15 P140 to P147 (port 14) .....	89
2.2.16 P150 to P156 (port 15) .....	91
2.2.17 V <sub>DD</sub> , EV <sub>DD0</sub> , EV <sub>DD1</sub> , V <sub>SS</sub> , EV <sub>SS0</sub> , EV <sub>SS1</sub> .....	91
2.2.18 $\overline{\text{RESET}}$ .....	91
2.2.19 REGC.....	91
<b>2.3 Pin I/O Circuits and Recommended Connection of Unused Pins .....</b>	<b>92</b>



<b>CHAPTER 3 CPU ARCHITECTURE .....</b>	<b>98</b>
<b>3.1 Memory Space .....</b>	<b>98</b>
3.1.1 Internal program memory space.....	114
3.1.2 Mirror area.....	117
3.1.3 Internal data memory space.....	119
3.1.4 Special function register (SFR) area .....	120
3.1.5 Extended special function register (2nd SFR: 2nd Special Function Register) area .....	120
3.1.6 Data memory addressing .....	121
<b>3.2 Processor Registers.....</b>	<b>131</b>
3.2.1 Control registers .....	131
3.2.2 General-purpose registers.....	133
3.2.3 ES and CS registers.....	135
3.2.4 Special function registers (SFRs).....	136
3.2.5 Extended special function registers (2nd SFRs: 2nd Special Function Registers) .....	142
<b>3.3 Instruction Address Addressing.....</b>	<b>151</b>
3.3.1 Relative addressing.....	151
3.3.2 Immediate addressing.....	151
3.3.3 Table indirect addressing .....	152
3.3.4 Register direct addressing.....	153
<b>3.4 Addressing for Processing Data Addresses .....</b>	<b>154</b>
3.4.1 Implied addressing .....	154
3.4.2 Register addressing .....	154
3.4.3 Direct addressing .....	155
3.4.4 Short direct addressing .....	156
3.4.5 SFR addressing.....	157
3.4.6 Register indirect addressing.....	158
3.4.7 Based addressing.....	159
3.4.8 Based indexed addressing .....	162
3.4.9 Stack addressing.....	163
 <b>CHAPTER 4 PORT FUNCTIONS .....</b>	 <b>164</b>
<b>4.1 Port Functions .....</b>	<b>164</b>
<b>4.2 Port Configuration.....</b>	<b>165</b>
4.2.1 Port 0.....	167
4.2.2 Port 1.....	175
4.2.3 Port 2.....	185
4.2.4 Port 3.....	187
4.2.5 Port 4.....	192
4.2.6 Port 5.....	201
4.2.7 Port 6.....	208

4.2.8 Port 7.....	211
4.2.9 Port 8.....	218
4.2.10 Port 9.....	222
4.2.11 Port 10.....	227
4.2.12 Port 11.....	231
4.2.13 Port 12.....	234
4.2.14 Port 13.....	239
4.2.15 Port 14.....	241
4.2.16 Port 15.....	249
<b>4.3 Registers Controlling Port Function .....</b>	<b>251</b>
<b>4.4 Port Function Operations .....</b>	<b>270</b>
4.4.1 Writing to I/O port .....	270
4.4.2 Reading from I/O port.....	270
4.4.3 Operations on I/O port.....	270
4.4.4 Connecting to external device with different potential (1.8 V, 2.5 V, 3 V) .....	271
<b>4.5 Settings of Port Mode Register, and Output Latch When Using Alternate Function.....</b>	<b>273</b>
<b>4.6 Cautions When Using Port Function.....</b>	<b>279</b>
4.6.1 Cautions on 1-Bit Manipulation Instruction for Port Register n (Pn) .....	279
4.6.2 Cautions on the pin settings on the products other than 128-pin.....	280
<b>CHAPTER 5 CLOCK GENERATOR .....</b>	<b>282</b>
<b>5.1 Functions of Clock Generator .....</b>	<b>282</b>
<b>5.2 Configuration of Clock Generator .....</b>	<b>284</b>
<b>5.3 Registers Controlling Clock Generator.....</b>	<b>286</b>
<b>5.4 System Clock Oscillator .....</b>	<b>302</b>
5.4.1 X1 oscillator.....	302
5.4.2 XT1 oscillator.....	302
5.4.3 High-speed on-chip oscillator .....	306
5.4.4 Low-speed on-chip oscillator .....	306
<b>5.5 Clock Generator Operation .....</b>	<b>307</b>
<b>5.6 Controlling Clock.....</b>	<b>309</b>
5.6.1 Example of setting high-speed on-chip oscillator .....	309
5.6.2 Example of setting X1 oscillation clock.....	310
5.6.3 Example of setting XT1 oscillation clock .....	311
5.6.4 CPU clock status transition diagram.....	312
5.6.5 Condition before changing CPU clock and processing after changing CPU clock .....	318
5.6.6 Time required for switchover of CPU clock and main system clock .....	320
5.6.7 Conditions before clock oscillation is stopped .....	321
<b>CHAPTER 6 TIMER ARRAY UNIT.....</b>	<b>322</b>
<b>6.1 Functions of Timer Array Unit.....</b>	<b>324</b>

6.1.1	Independent channel operation function .....	324
6.1.2	Simultaneous channel operation function.....	325
6.1.3	8-bit timer operation function (channels 1 and 3 only).....	326
6.1.4	LIN-bus supporting function (channel 7 of unit 0 only) .....	327
<b>6.2</b>	<b>Configuration of Timer Array Unit .....</b>	<b>328</b>
<b>6.3</b>	<b>Registers Controlling Timer Array Unit.....</b>	<b>334</b>
<b>6.4</b>	<b>Basic Rules of Timer Array Unit .....</b>	<b>359</b>
6.4.1	Basic rules of simultaneous channel operation function.....	359
6.4.2	Basic rules of 8-bit timer operation function (channels 1 and 3 only) .....	361
<b>6.5</b>	<b>Operation Timing of Counter .....</b>	<b>362</b>
6.5.1	Count clock (fTCLK) .....	362
6.5.2	Start timing of counter .....	364
<b>6.6</b>	<b>Channel Output (TOmn pin) Control .....</b>	<b>370</b>
6.6.1	TOmn pin output circuit configuration.....	370
6.6.2	TOmn Pin Output Setting .....	371
6.6.3	Cautions on Channel Output Operation .....	372
6.6.4	Collective manipulation of TOmn bit.....	378
6.6.5	Timer Interrupt and TOmn Pin Output at Operation Start.....	379
<b>6.7</b>	<b>Independent Channel Operation Function of Timer Array Unit.....</b>	<b>380</b>
6.7.1	Operation as interval timer/square wave output .....	380
6.7.2	Operation as external event counter .....	386
6.7.3	Operation as frequency divider (channel 0 of unit 0 only) .....	391
6.7.4	Operation as input pulse interval measurement .....	395
6.7.5	Operation as input signal high-/low-level width measurement.....	399
6.7.6	Operation as delay counter .....	403
<b>6.8</b>	<b>Simultaneous Channel Operation Function of Timer Array Unit .....</b>	<b>408</b>
6.8.1	Operation as one-shot pulse output function .....	408
6.8.2	Operation as PWM function.....	415
6.8.3	Operation as multiple PWM output function .....	422
<b>6.9</b>	<b>Cautions When Using Timer Array Unit.....</b>	<b>430</b>
6.9.1	Cautions When Using Timer output.....	430
<b>CHAPTER 7</b>	<b>REAL-TIME CLOCK.....</b>	<b>431</b>
<b>7.1</b>	<b>Functions of Real-time Clock.....</b>	<b>431</b>
<b>7.2</b>	<b>Configuration of Real-time Clock .....</b>	<b>431</b>
<b>7.3</b>	<b>Registers Controlling Real-time Clock.....</b>	<b>433</b>
<b>7.4</b>	<b>Real-time Clock Operation .....</b>	<b>448</b>
7.4.1	Starting operation of real-time clock.....	448
7.4.2	Shifting to STOP mode after starting operation.....	449
7.4.3	Reading/writing real-time clock.....	450
7.4.4	Setting alarm of real-time clock .....	452

7.4.5	1 Hz output of real-time clock .....	453
7.4.6	Example of watch error correction of real-time clock .....	454
<b>CHAPTER 8</b>	<b>INTERVAL TIMER .....</b>	<b>457</b>
<b>8.1</b>	<b>Functions of Interval Timer .....</b>	<b>457</b>
<b>8.2</b>	<b>Configuration of Interval Timer .....</b>	<b>457</b>
<b>8.3</b>	<b>Registers Controlling Interval Timer .....</b>	<b>458</b>
<b>8.4</b>	<b>Interval Timer Operation .....</b>	<b>461</b>
<b>CHAPTER 9</b>	<b>CLOCK OUTPUT/BUZZER OUTPUT CONTROLLER.....</b>	<b>462</b>
<b>9.1</b>	<b>Functions of Clock Output/Buzzer Output Controller .....</b>	<b>462</b>
<b>9.2</b>	<b>Configuration of Clock Output/Buzzer Output Controller.....</b>	<b>464</b>
<b>9.3</b>	<b>Registers Controlling Clock Output/Buzzer Output Controller .....</b>	<b>464</b>
<b>9.4</b>	<b>Operations of Clock Output/Buzzer Output Controller .....</b>	<b>467</b>
9.4.1	Operation as output pin .....	467
<b>CHAPTER 10</b>	<b>WATCHDOG TIMER .....</b>	<b>468</b>
<b>10.1</b>	<b>Functions of Watchdog Timer.....</b>	<b>468</b>
<b>10.2</b>	<b>Configuration of Watchdog Timer .....</b>	<b>469</b>
<b>10.3</b>	<b>Register Controlling Watchdog Timer.....</b>	<b>470</b>
<b>10.4</b>	<b>Operation of Watchdog Timer.....</b>	<b>471</b>
10.4.1	Controlling operation of watchdog timer .....	471
10.4.2	Setting overflow time of watchdog timer .....	472
10.4.3	Setting window open period of watchdog timer .....	473
10.4.4	Setting watchdog timer interval interrupt .....	474
<b>CHAPTER 11</b>	<b>A/D CONVERTER .....</b>	<b>475</b>
<b>11.1</b>	<b>Function of A/D Converter.....</b>	<b>475</b>
<b>11.2</b>	<b>Configuration of A/D Converter .....</b>	<b>477</b>
<b>11.3</b>	<b>Registers Used in A/D Converter.....</b>	<b>479</b>
<b>11.4</b>	<b>A/D Converter Conversion Operations .....</b>	<b>504</b>
<b>11.5</b>	<b>Input Voltage and Conversion Results .....</b>	<b>506</b>
<b>11.6</b>	<b>A/D Converter Operation Modes.....</b>	<b>507</b>
11.6.1	Software trigger mode (select mode, sequential conversion mode) .....	507
11.6.2	Software trigger mode (select mode, one-shot conversion mode) .....	508
11.6.3	Software trigger mode (scan mode, sequential conversion mode).....	509
11.6.4	Software trigger mode (scan mode, one-shot conversion mode) .....	510
11.6.5	Hardware trigger no-wait mode (select mode, sequential conversion mode) .....	511
11.6.6	Hardware trigger no-wait mode (select mode, one-shot conversion mode).....	512
11.6.7	Hardware trigger no-wait mode (scan mode, sequential conversion mode).....	513

11.6.8	Hardware trigger no-wait mode (scan mode, one-shot conversion mode)	514
11.6.9	Hardware trigger wait mode (select mode, sequential conversion mode)	515
11.6.10	Hardware trigger wait mode (select mode, one-shot conversion mode)	516
11.6.11	Hardware trigger wait mode (scan mode, sequential conversion mode)	517
11.6.12	Hardware trigger wait mode (scan mode, one-shot conversion mode)	518
<b>11.7</b>	<b>A/D Converter Setup Flowchart</b>	<b>519</b>
11.7.1	Setting up software trigger mode	520
11.7.2	Setting up hardware trigger no-wait mode	521
11.7.3	Setting up hardware trigger wait mode	522
11.7.4	Setup when using temperature sensor (example for software trigger mode and one-shot conversion mode)	523
11.7.5	Setting up test mode	524
<b>11.8</b>	<b>SNOOZE Mode Function</b>	<b>525</b>
<b>11.9</b>	<b>How to Read A/D Converter Characteristics Table</b>	<b>528</b>
<b>11.10</b>	<b>Cautions for A/D Converter</b>	<b>530</b>
<b>CHAPTER 12</b>	<b>SERIAL ARRAY UNIT</b>	<b>534</b>
<b>12.1</b>	<b>Functions of Serial Array Unit</b>	<b>536</b>
12.1.1	3-wire serial I/O (CSI00, CSI01, CSI10, CSI11, CSI20, CSI21, CSI30, CSI31)	536
12.1.2	UART (UART0 to UART3)	537
12.1.3	Simplified I <sup>2</sup> C (IIC00, IIC01, IIC10, IIC11, IIC20, IIC21, IIC30, IIC31)	538
<b>12.2</b>	<b>Configuration of Serial Array Unit</b>	<b>539</b>
<b>12.3</b>	<b>Registers Controlling Serial Array Unit</b>	<b>545</b>
<b>12.4</b>	<b>Operation stop mode</b>	<b>571</b>
12.4.1	Stopping the operation by units	572
12.4.2	Stopping the operation by channels	573
<b>12.5</b>	<b>Operation of 3-Wire Serial I/O (CSI00, CSI01, CSI10, CSI11, CSI20, CSI21, CSI30, CSI31) Communication</b>	<b>574</b>
12.5.1	Master transmission	577
12.5.2	Master reception	587
12.5.3	Master transmission/reception	596
12.5.4	Slave transmission	605
12.5.5	Slave reception	614
12.5.6	Slave transmission/reception	621
12.5.7	SNOOZE mode function	631
12.5.8	Calculating transfer clock frequency	635
12.5.9	Procedure for processing errors that occurred during 3-wire serial I/O (CSI00, CSI01, CSI10, CSI11, CSI20, CSI21, CSI30, CSI31) communication	637
<b>12.6</b>	<b>Operation of UART (UART0 to UART3) Communication</b>	<b>638</b>
12.6.1	UART transmission	641
12.6.2	UART reception	651

12.6.3 SNOOZE mode function.....	658
12.6.4 Calculating baud rate .....	663
12.6.5 Procedure for processing errors that occurred during UART (UART0 to UART3) communication.....	667
<b>12.7 LIN Communication Operation .....</b>	<b>668</b>
12.7.1 LIN transmission.....	668
12.7.2 LIN reception .....	671
<b>12.8 Operation of Simplified I<sup>2</sup>C (IIC00, IIC01, IIC10, IIC11, IIC20, IIC21, IIC30, IIC31) Communication .....</b>	<b>677</b>
12.8.1 Address field transmission.....	680
12.8.2 Data transmission.....	686
12.8.3 Data reception .....	690
12.8.4 Stop condition generation.....	695
12.8.5 Calculating transfer rate .....	696
12.8.6 Procedure for processing errors that occurred during simplified I <sup>2</sup> C (IIC00, IIC01, IIC10, IIC11, IIC20, IIC21, IIC30, IIC31) communication .....	698
<b>CHAPTER 13 SERIAL INTERFACE IICA .....</b>	<b>699</b>
<b>13.1 Functions of Serial Interface IICA.....</b>	<b>699</b>
<b>13.2 Configuration of Serial Interface IICA .....</b>	<b>702</b>
<b>13.3 Registers Controlling Serial Interface IICA.....</b>	<b>705</b>
<b>13.4 I<sup>2</sup>C Bus Mode Functions.....</b>	<b>719</b>
13.4.1 Pin configuration.....	719
13.4.2 Setting transfer clock by using IICWL0 and IICWH0 registers.....	720
<b>13.5 I<sup>2</sup>C Bus Definitions and Control Methods .....</b>	<b>722</b>
13.5.1 Start conditions.....	722
13.5.2 Addresses .....	723
13.5.3 Transfer direction specification .....	723
13.5.4 Acknowledge ( $\overline{ACK}$ ) .....	724
13.5.5 Stop condition.....	725
13.5.6 Wait .....	726
13.5.7 Canceling wait .....	728
13.5.8 Interrupt request (INTIICA0) generation timing and wait control.....	729
13.5.9 Address match detection method .....	730
13.5.10 Error detection.....	730
13.5.11 Extension code.....	730
13.5.12 Arbitration .....	731
13.5.13 Wakeup function.....	733
13.5.14 Communication reservation.....	736
13.5.15 Cautions .....	740
13.5.16 Communication operations.....	741
13.5.17 Timing of I <sup>2</sup> C interrupt request (INTIICA0) occurrence .....	748

13.6 Timing Charts .....	769
<b>CHAPTER 14 MULTIPLIER AND DIVIDER/MULTIPLY-ACCUMULATOR .....</b>	<b>784</b>
14.1 Functions of Multiplier and Divider/Multiply-Accumulator .....	784
14.2 Configuration of Multiplier and Divider/Multiply-Accumulator .....	784
14.3 Register Controlling Multiplier and Divider/Multiply-Accumulator .....	790
14.4 Operations of Multiplier and Divider/Multiply-Accumulator .....	792
14.4.1 Multiplication (unsigned) operation .....	792
14.4.2 Multiplication (signed) operation .....	793
14.4.3 Multiply-accumulation (unsigned) operation .....	794
14.4.4 Multiply-accumulation (signed) operation .....	796
14.4.5 Division operation .....	798
<b>CHAPTER 15 DMA CONTROLLER .....</b>	<b>800</b>
15.1 Functions of DMA Controller .....	800
15.2 Configuration of DMA Controller .....	801
15.3 Registers Controlling DMA Controller .....	804
15.4 Operation of DMA Controller .....	809
15.4.1 Operation procedure .....	809
15.4.2 Transfer mode .....	810
15.4.3 Termination of DMA transfer .....	810
15.5 Example of Setting of DMA Controller .....	811
15.5.1 CSI consecutive transmission .....	811
15.5.2 Consecutive capturing of A/D conversion results .....	813
15.5.3 UART consecutive reception + ACK transmission .....	815
15.5.4 Holding DMA transfer pending by DWAITn bit .....	817
15.5.5 Forced termination by software .....	818
15.6 Cautions on Using DMA Controller .....	820
<b>CHAPTER 16 INTERRUPT FUNCTIONS .....</b>	<b>822</b>
16.1 Interrupt Function Types .....	822
16.2 Interrupt Sources and Configuration .....	822
16.3 Registers Controlling Interrupt Functions .....	829
16.4 Interrupt Servicing Operations .....	842
16.4.1 Maskable interrupt request acknowledgment .....	842
16.4.2 Software interrupt request acknowledgment .....	845
16.4.3 Multiple interrupt servicing .....	845
16.4.4 Interrupt request hold .....	849

<b>CHAPTER 17 KEY INTERRUPT FUNCTION .....</b>	<b>850</b>
<b>17.1 Functions of Key Interrupt .....</b>	<b>850</b>
<b>17.2 Configuration of Key Interrupt .....</b>	<b>850</b>
<b>17.3 Register Controlling Key Interrupt .....</b>	<b>852</b>
<b>CHAPTER 18 STANDBY FUNCTION .....</b>	<b>853</b>
<b>18.1 Standby Function and Configuration .....</b>	<b>853</b>
18.1.1 Standby function.....	853
18.1.2 Registers controlling standby function.....	854
<b>18.2 Standby Function Operation .....</b>	<b>857</b>
18.2.1 HALT mode .....	857
18.2.2 STOP mode.....	862
18.2.3 SNOOZE mode .....	867
<b>CHAPTER 19 RESET FUNCTION.....</b>	<b>869</b>
<b>19.1 Register for Confirming Reset Source .....</b>	<b>879</b>
<b>CHAPTER 20 POWER-ON-RESET CIRCUIT .....</b>	<b>881</b>
<b>20.1 Functions of Power-on-reset Circuit .....</b>	<b>881</b>
<b>20.2 Configuration of Power-on-reset Circuit.....</b>	<b>882</b>
<b>20.3 Operation of Power-on-reset Circuit .....</b>	<b>882</b>
<b>20.4 Cautions for Power-on-reset Circuit.....</b>	<b>885</b>
<b>CHAPTER 21 VOLTAGE DETECTOR.....</b>	<b>887</b>
<b>21.1 Functions of Voltage Detector .....</b>	<b>887</b>
<b>21.2 Configuration of Voltage Detector.....</b>	<b>888</b>
<b>21.3 Registers Controlling Voltage Detector .....</b>	<b>888</b>
<b>21.4 Operation of Voltage Detector .....</b>	<b>893</b>
21.4.1 When used as reset mode.....	893
21.4.2 When used as interrupt mode .....	895
21.4.3 When used as interrupt and reset mode .....	897
<b>21.5 Cautions for Voltage Detector.....</b>	<b>900</b>
<b>CHAPTER 22 SAFETY FUNCTIONS.....</b>	<b>902</b>
<b>22.1 Overview of Safety Functions .....</b>	<b>902</b>
<b>22.2 Registers Used by Safety Functions.....</b>	<b>903</b>
<b>22.3 Operation of Safety Functions .....</b>	<b>903</b>
22.3.1 Flash memory CRC operation function (high-speed CRC).....	903
22.3.2 CRC operation function (general-purpose CRC) .....	907



22.3.3	RAM parity error detection function .....	909
22.3.4	RAM guard function.....	910
22.3.5	SFR guard function .....	911
22.3.6	Invalid memory access detection function.....	912
22.3.7	Frequency detection function .....	914
22.3.8	A/D test function.....	916
<b>CHAPTER 23</b>	<b>REGULATOR .....</b>	<b>920</b>
23.1	Regulator Overview.....	920
<b>CHAPTER 24</b>	<b>OPTION BYTE.....</b>	<b>921</b>
24.1	Functions of Option Bytes .....	921
24.1.1	User option byte (000C0H to 000C2H/010C0H to 010C2H).....	921
24.1.2	On-chip debug option byte (000C3H/ 010C3H).....	922
24.2	Format of User Option Byte .....	923
24.3	Format of On-chip Debug Option Byte.....	927
24.4	Setting of Option Byte.....	928
<b>CHAPTER 25</b>	<b>FLASH MEMORY .....</b>	<b>929</b>
25.1	Writing to Flash Memory by Using Flash Memory Programmer .....	930
25.1.1	Programming Environment.....	932
25.1.2	Communication Mode .....	932
25.2	Writing to Flash Memory by Using External Device (that Incorporates UART).....	933
25.2.1	Programming Environment.....	933
25.2.2	Communication Mode .....	934
25.3	Connection of Pins on Board.....	935
25.3.1	P40/TOOL0 pin .....	935
25.3.2	RESET pin.....	935
25.3.3	Port pins .....	936
25.3.4	REGC pin .....	936
25.3.5	X1 and X2 pins.....	936
25.3.6	Power supply.....	936
25.4	Data Flash .....	937
25.4.1	Data flash overview .....	937
25.4.2	Register controlling data flash memory .....	938
25.4.3	Procedure for accessing data flash memory .....	939
25.5	Programming Method .....	940
25.5.1	Controlling flash memory.....	940
25.5.2	Flash memory programming mode.....	941
25.5.3	Selecting communication mode.....	942

25.5.4	Communication commands .....	943
25.5.5	Description of signature data .....	944
<b>25.6</b>	<b>Security Settings .....</b>	<b>945</b>
<b>25.7</b>	<b>Flash Memory Programming by Self-Programming .....</b>	<b>947</b>
25.7.1	Boot swap function .....	949
25.7.2	Flash shield window function .....	951
<b>CHAPTER 26</b>	<b>ON-CHIP DEBUG FUNCTION .....</b>	<b>952</b>
<b>26.1</b>	<b>Connecting E1 On-chip Debugging Emulator to RL78/G13 .....</b>	<b>952</b>
<b>26.2</b>	<b>On-Chip Debug Security ID .....</b>	<b>953</b>
<b>26.3</b>	<b>Securing of User Resources .....</b>	<b>953</b>
<b>CHAPTER 27</b>	<b>BCD CORRECTION CIRCUIT .....</b>	<b>955</b>
<b>27.1</b>	<b>BCD Correction Circuit Function .....</b>	<b>955</b>
<b>27.2</b>	<b>Registers Used by BCD Correction Circuit .....</b>	<b>955</b>
<b>27.3</b>	<b>BCD Correction Circuit Operation .....</b>	<b>956</b>
<b>CHAPTER 28</b>	<b>INSTRUCTION SET .....</b>	<b>958</b>
<b>28.1</b>	<b>Conventions Used in Operation List .....</b>	<b>959</b>
28.1.1	Operand identifiers and specification methods .....	959
28.1.2	Description of operation column .....	960
28.1.3	Description of flag operation column .....	961
28.1.4	PREFIX instruction .....	961
<b>28.2</b>	<b>Operation List .....</b>	<b>962</b>
<b>CHAPTER 29</b>	<b>ELECTRICAL SPECIFICATIONS .....</b>	<b>979</b>
<b>29.1</b>	<b>Pins Mounted According to Product .....</b>	<b>979</b>
29.1.1	Port functions .....	979
29.1.2	Non-port functions .....	979
<b>29.2</b>	<b>Absolute Maximum Ratings .....</b>	<b>980</b>
<b>29.3</b>	<b>Oscillator Characteristics .....</b>	<b>982</b>
29.3.1	Main system clock oscillator characteristics .....	982
29.3.2	On-chip oscillator characteristics .....	983
29.3.3	Subsystem clock oscillator characteristics .....	984
29.3.4	Recommended Oscillator Constants .....	985
<b>29.4</b>	<b>DC Characteristics .....</b>	<b>988</b>
29.4.1	Pin characteristics .....	988
29.4.2	Supply current characteristics .....	993
<b>29.5</b>	<b>AC Characteristics .....</b>	<b>1006</b>
29.5.1	Basic operation .....	1006

<b>29.6 Peripheral Functions Characteristics.....</b>	<b>1008</b>
29.6.1 Serial array unit .....	1008
29.6.2 Serial interface IICA .....	1031
29.6.3 On-chip debug (UART).....	1032
<b>29.7 Analog Characteristics .....</b>	<b>1032</b>
29.7.1 A/D converter characteristics.....	1032
29.7.2 Temperature sensor characteristics .....	1036
29.7.3 POR circuit characteristics .....	1036
29.7.4 LVD circuit characteristics .....	1037
<b>29.8 Data Memory STOP Mode Low Supply Voltage Data Retention Characteristics.....</b>	<b>1040</b>
<b>29.9 Flash Memory Programming Characteristics.....</b>	<b>1040</b>
<b>29.10 Timing Specs for Switching Modes.....</b>	<b>1041</b>
<b>CHAPTER 30 PACKAGE DRAWINGS .....</b>	<b>1042</b>
<b>30.1 20-pin products.....</b>	<b>1042</b>
<b>30.2 24-pin products.....</b>	<b>1043</b>
<b>30.3 25-pin products.....</b>	<b>1044</b>
<b>30.4 30-pin products.....</b>	<b>1045</b>
<b>30.5 32-pin products.....</b>	<b>1046</b>
<b>30.6 36-pin products.....</b>	<b>1047</b>
<b>30.7 40-pin products.....</b>	<b>1048</b>
<b>30.8 44-pin products.....</b>	<b>1049</b>
<b>30.9 48-pin products.....</b>	<b>1050</b>
<b>30.10 52-pin products.....</b>	<b>1052</b>
<b>30.11 64-pin products.....</b>	<b>1053</b>
<b>30.12 80-pin products.....</b>	<b>1057</b>
<b>30.13 100-pin products.....</b>	<b>1059</b>
<b>30.14 128-pin products.....</b>	<b>1061</b>
<b>APPENDIX A REVISION HISTORY .....</b>	<b>1062</b>
<b>A.1 Major Revisions in This Edition .....</b>	<b>1062</b>
<b>A.2 Revision History of Preceding Editions .....</b>	<b>1069</b>

## CHAPTER 1 OUTLINE

### 1.1 Features

- Minimum instruction execution time can be changed from high speed (0.03125  $\mu$ s: @ 32 MHz operation with high-speed on-chip oscillator) to ultra low-speed (30.5  $\mu$ s: @ 32.768 kHz operation with subsystem clock)
- General-purpose register: 8 bits  $\times$  32 registers (8 bits  $\times$  8 registers  $\times$  4 banks)
- ROM: 16 to 512 KB, RAM: 2 to 32 KB, Data flash memory:  $\sim$ 4/8 KB
- On-chip high-speed on-chip oscillator
  - Select from 32 MHz (TYP.), 24 MHz (TYP.), 16 MHz (TYP.), 12 MHz (TYP.), 8 MHz (TYP.), 4 MHz (TYP.), and 1 MHz (TYP.)
- On-chip single-power-supply flash memory (with prohibition of block erase/writing function)
- Self-programming (with boot swap function/flash shield window function)
- On-chip debug function
- On-chip power-on-reset (POR) circuit and voltage detector (LVD)
- On-chip watchdog timer (operable with the dedicated low-speed on-chip oscillator)
- On-chip multiplier and divider/multiply-accumulator
  - 16 bits  $\times$  16 bits = 32 bits (Unsigned or signed)
  - 32 bits  $\div$  32 bits = 32 bits (Unsigned)
  - 16 bits  $\times$  16 bits + 32 bits = 32 bits (Unsigned or signed)
- On-chip key interrupt function
- On-chip clock output/buzzer output controller
- On-chip BCD adjustment
- I/O ports: 16 to 120 (N-ch open drain: 0 to 4)
- Timer
  - 16-bit timer: 8 to 16 channels
  - Watchdog timer: 1 channel
  - Real-time clock: 1 channel (Correction clock output)
  - Interval timer: 1 channel
- Serial interface
  - CSI
  - UART/UART (LIN-bus supported)
  - I<sup>2</sup>C/Simplified I<sup>2</sup>C communication
- Different potential interface: Can connect to a 2.5/3 V device when operating at 4.0 V to 5.5 V
- 8/10-bit resolution A/D converter ( $V_{DD} = EV_{DD} = 1.6$  to 5.5 V): 6 to 26 channels
- Standby function: HALT, STOP, SNOOZE mode
- Power supply voltage:  $V_{DD} = 1.6$  to 5.5 V
- Operating ambient temperature:  $T_A = -40$  to  $+85^{\circ}\text{C}$

**Remark** The functions mounted depend on the product. See **1.6 Outline of Functions**.

○ ROM, RAM capacities

Flash ROM	Data flash	RAM	RL78/G13					
			20 pins	24 pins	25 pins	30 pins	32 pins	36 pins
128 KB	8 KB	12 KB	–	–	–	R5F100AG	R5F100BG	R5F100CG
	–		–	–	R5F101AG	R5F101BG	R5F101CG	
96 KB	8 KB	8 KB	–	–	–	R5F100AF	R5F100BF	R5F100CF
	–		–	–	R5F101AF	R5F101BF	R5F101CF	
64 KB	4 KB	4 KB Note 1	R5F1006E	R5F1007E	R5F1008E	R5F100AE	R5F100BE	R5F100CE
	–		R5F1016E	R5F1017E	R5F1018E	R5F101AE	R5F101BE	R5F101CE
48 KB	4 KB	3 KB	R5F1006D	R5F1007D	R5F1008D	R5F100AD	R5F100BD	R5F100CD
	–		R5F1016D	R5F1017D	R5F1018D	R5F101AD	R5F101BD	R5F101CD
32 KB	4 KB	2 KB	R5F1006C	R5F1007C	R5F1008C	R5F100AC	R5F100BC	R5F100CC
	–		R5F1016C	R5F1017C	R5F1018C	R5F101AC	R5F101BC	R5F101CC
16 KB	4 KB	2 KB	R5F1006A	R5F1007A	R5F1008A	R5F100AA	R5F100BA	R5F100CA
	–		R5F1016A	R5F1017A	R5F1018A	R5F101AA	R5F101BA	R5F101CA

Flash ROM	Data flash	RAM	RL78/G13							
			40 pins	44 pins	48 pins	52 pins	64 pins	80 pins	100 pins	128 pins
512 KB	8 KB	32 KB Note 3	–	R5F100FL	R5F100GL	R5F100JL	R5F100LL	R5F100ML	R5F100PL	R5F100SL
	–		–	R5F101FL	R5F101GL	R5F101JL	R5F101LL	R5F101ML	R5F101PL	R5F101SL
384 KB	8 KB	24 KB	–	R5F100FK	R5F100GK	R5F100JK	R5F100LK	R5F100MK	R5F100PK	R5F100SK
	–		–	R5F101FK	R5F101GK	R5F101JK	R5F101LK	R5F101MK	R5F101PK	R5F101SK
256 KB	8 KB	20 KB Note 2	–	R5F100FJ	R5F100GJ	R5F100JJ	R5F100LJ	R5F100MJ	R5F100PJ	R5F100SJ
	–		–	R5F101FJ	R5F101GJ	R5F101JJ	R5F101LJ	R5F101MJ	R5F101PJ	R5F101SJ
192 KB	8 KB	16 KB	R5F100EH	R5F100FH	R5F100GH	R5F100JH	R5F100LH	R5F100MH	R5F100PH	R5F100SH
	–		R5F101EH	R5F101FH	R5F101GH	R5F101JH	R5F101LH	R5F101MH	R5F101PH	R5F101SH
128 KB	8 KB	12 KB	R5F100EG	R5F100FG	R5F100GG	R5F100JG	R5F100LG	R5F100MG	R5F100PG	–
	–		R5F101EG	R5F101FG	R5F101GG	R5F101JG	R5F101LG	R5F101MG	R5F101PG	–
96 KB	8 KB	8 KB	R5F100EF	R5F100FF	R5F100GF	R5F100JF	R5F100LF	R5F100MF	R5F100PF	–
	–		R5F101EF	R5F101FF	R5F101GF	R5F101JF	R5F101LF	R5F101MF	R5F101PF	–
64 KB	4 KB	4 KB Note 1	R5F100EE	R5F100FE	R5F100GE	R5F100JE	R5F100LE	–	–	–
	–		R5F101EE	R5F101FE	R5F101GE	R5F101JE	R5F101LE	–	–	–
48 KB	4 KB	3 KB	R5F100ED	R5F100FD	R5F100GD	R5F100JD	R5F100LD	–	–	–
	–		R5F101ED	R5F101FD	R5F101GD	R5F101JD	R5F101LD	–	–	–
32 KB	4 KB	2 KB	R5F100EC	R5F100FC	R5F100GC	R5F100JC	R5F100LC	–	–	–
	–		R5F101EC	R5F101FC	R5F101GC	R5F101JC	R5F101LC	–	–	–
16 KB	4 KB	2 KB	R5F100EA	R5F100FA	R5F100GA	–	–	–	–	–
	–		R5F101EA	R5F101FA	R5F101GA	–	–	–	–	–

- <R> **Notes** 1. This is about 3 KB when the self-programming function and data flash function are used. (For details, see **CHAPTER 3**)
- <R> 2. This is about 19 KB when the self-programming function and data flash function are used. (For details, see **CHAPTER 3**)
- <R> 3. This is about 31 KB when the self-programming function and data flash function are used. (For details, see **CHAPTER 3**)

## 1.2 Ordering Information

- Flash memory version (lead-free product)

(1/3)

Pin count	Package	Data flash	Part Number
20 pins	20-pin plastic SSOP (7.62 mm (300))	Mounted	R5F1006AASP, R5F1006CASP, R5F1006DASP, R5F1006EASP
		Not mounted	R5F1016AASP, R5F1016CASP, R5F1016DASP, R5F1016EASP
24 pins	24-pin plastic WQFN (fine pitch) (4 × 4)	Mounted	R5F1007AANA, R5F1007CANA, R5F1007DANA, R5F1007EANA
		Not mounted	R5F1017AANA, R5F1017CANA, R5F1017DANA, R5F1017EANA
25 pins	25-pin plastic FLGA (3 × 3)	Mounted	R5F1008AALA, R5F1008CALA, R5F1008DALA, R5F1008EALA
		Not mounted	R5F1018AALA, R5F1018CALA, R5F1018DALA, R5F1018EALA
30 pins	30-pin plastic SSOP (7.62 mm (300))	Mounted	R5F100AAASP, R5F100ACASP, R5F100ADASP, R5F100AEASP, R5F100AFASP, R5F100AGASP
		Not mounted	R5F101AAASP, R5F101ACASP, R5F101ADASP, R5F101AEASP, R5F101AFASP, R5F101AGASP
32 pins	32-pin plastic WQFN (fine pitch)(5 × 5)	Mounted	R5F100BAANA, R5F100BCANA, R5F100BDANA, R5F100BEANA, R5F100BFANA, R5F100BGANA
		Not mounted	R5F101BAANA, R5F101BCANA, R5F101BDANA, R5F101BEANA, R5F101BFANA, R5F101BGANA
36 pins	36-pin plastic FLGA (4 × 4)	Mounted	R5F100CAALA, R5F100CCALA, R5F100CDALA, R5F100CEALA, R5F100CFALA, R5F100CGALA
		Not mounted	R5F101CAALA, R5F101CCALA, R5F101CDALA, R5F101CEALA, R5F101CFALA, R5F101CGALA
40 pins	40-pin plastic WQFN (fine pitch)(6 × 6)	Mounted	R5F100EAANA, R5F100ECANA, R5F100EDANA, R5F100EEANA, R5F100EFANA, R5F100EGANA, R5F100EHANA
		Not mounted	R5F101EAANA, R5F101ECANA, R5F101EDANA, R5F101EEANA, R5F101EFANA, R5F101EGANA, R5F101EHANA
44 pins	44-pin plastic LQFP (10 × 10)	Mounted	R5F100FAAFP, R5F100FCAFP, R5F100FDAFP, R5F100FEAFP, R5F100FFAFP, R5F100FGAFP, R5F100FHAFP, R5F100FJAFP, R5F100FKAFP, R5F100FLAFP
		Not mounted	R5F101FAAFP, R5F101FCAFP, R5F101FDAFP, R5F101FEAFP, R5F101FFAFP, R5F101FGAFP, R5F101FHAFP, R5F101FJAFP, R5F101FKAFP, R5F101FLAFP

(2/3)

Pin count	Package	Data flash	Part Number
48 pins	48-pin plastic LQFP (fine pitch) (7 × 7)	Mounted	R5F100GAAFB, R5F100GCAFB, R5F100GDAFB, R5F100GEAFB, R5F100GFAFB, R5F100GGAFB, R5F100GHAFB, R5F100GJAFB, R5F100GKAFB, R5F100GLAFB
		Not mounted	R5F101GAAFB, R5F101GCAFB, R5F101GDAFB, R5F101GEAFB, R5F101GFAFB, R5F101GGAFB, R5F101GHAFB, R5F101GJAFB, R5F101GKAFB, R5F101GLAFB
	48-pin plastic WQFN (7 × 7)	Mounted	R5F100GAANA, R5F100GCANA, R5F100GDANA, R5F100GEANA, R5F100GFANA, R5F100GGANA, R5F100GHANA, R5F100GJANA, R5F100GKANA, R5F100GLANA
		Not mounted	R5F101GAANA, R5F101GCANA, R5F101GDANA, R5F101GEANA, R5F101GFANA, R5F101GGANA, R5F101GHANA, R5F101GJANA, R5F101GKANA, R5F101GLANA
52 pins	52-pin plastic LQFP (10 × 10)	Mounted	R5F100JCAFA, R5F100JDAFA, R5F100JEAFA, R5F100JFAFA, R5F100JGAFA, R5F100JHAFB, R5F100JJFAFA, R5F100JKAFB, R5F100JLAFA
		Not mounted	R5F101JCAFA, R5F101JDAFA, R5F101JEAFA, R5F101JFAFA, R5F101JGAFA, R5F101JHAFB, R5F101JJFAFA, R5F101JKAFB, R5F101JLAFA
64 pins	64-pin plastic LQFP (12 × 12)	Mounted	R5F100LCAFA, R5F100LDAFA, R5F100LEAFA, R5F100LFAFA, R5F100LGAFB, R5F100LHAFB, R5F100LJAFB, R5F100LKAFB, R5F100LLAFA
		Not mounted	R5F101LCAFA, R5F101LDAFA, R5F101LEAFA, R5F101LFAFA, R5F101LGAFB, R5F101LHAFB, R5F101LJAFB, R5F101LKAFB, R5F101LLAFA
	64-pin plastic LQFP (fine pitch) (10 × 10)	Mounted	R5F100LCAFB, R5F100LDAFB, R5F100LEAFB, R5F100LFAFB, R5F100LGAFB, R5F100LHAFB, R5F100LJAFB, R5F100LKAFB, R5F100LLAFB
		Not mounted	R5F101LCAFB, R5F101LDAFB, R5F101LEAFB, R5F101LFAFB, R5F101LGAFB, R5F101LHAFB, R5F101LJAFB, R5F101LKAFB, R5F101LLAFB
	64-pin plastic TQFP (fine pitch) (7 × 7)	Mounted	R5F100LCAFC, R5F100LDAFC, R5F100LEAFC, R5F100LFAFC, R5F100LGAFC, R5F100LHAFB, R5F100LJAFB
		Not mounted	R5F101LCAFC, R5F101LDAFC, R5F101LEAFC, R5F101LFAFC, R5F101LGAFC, R5F101LHAFB, R5F101LJAFB
	64-pin plastic FBGA (4 × 4)	Mounted	R5F100LCABG, R5F100LDABG, R5F100LEABG, R5F100LFABG, R5F100LGABG, R5F100LHABG, R5F100LJABG
		Not mounted	R5F101LCABG, R5F101LDABG, R5F101LEABG, R5F101LFABG, R5F101LGABG, R5F101LHABG, R5F101LJABG

(3/3)

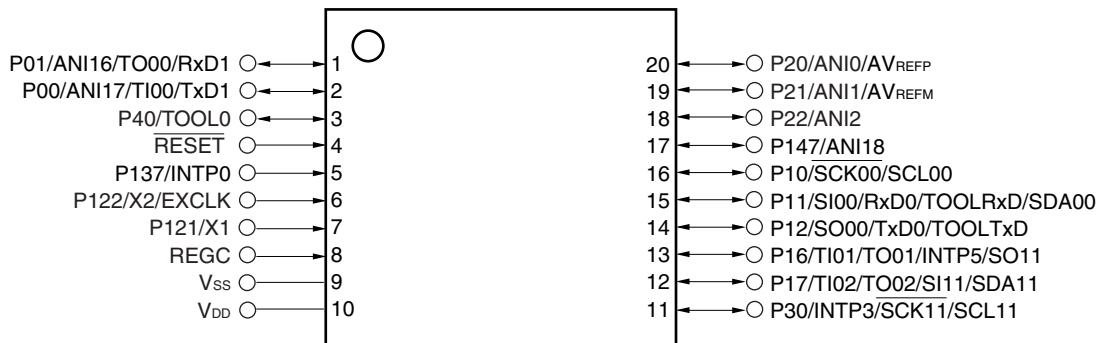
Pin count	Package	Data flash	Part Number
80 pins	80-pin plastic LQFP (14 × 14)	Mounted	R5F100MFAFA, R5F100MGAF A, R5F100MHAF A, R5F100MJAF A, R5F100MKAF A, R5F100MLAF A
		Not mounted	R5F101MFAFA, R5F101MGAF A, R5F101MHAF A, R5F101MJAF A, R5F101MKAF A, R5F101MLAF A
	80-pin plastic LQFP (fine pitch) (12 × 12)	Mounted	R5F100MFAFB, R5F100MGAF B, R5F100MHAF B, R5F100MJAF B, R5F100MKAF B, R5F100MLAF B
		Not mounted	R5F101MFAFB, R5F101MGAF B, R5F101MHAF B, R5F101MJAF B, R5F101MKAF B, R5F101MLAF B
100 pins	100-pin plastic LQFP (fine pitch) (14 × 14)	Mounted	R5F100PFAFB, R5F100PGAF B, R5F100PHAF B, R5F100PJAF B, R5F100PKAF B, R5F100PLAF B
		Not mounted	R5F101PFAFB, R5F101PGAF B, R5F101PHAF B, R5F101PJAF B, R5F101PKAF B, R5F101PLAF B
	100-pin plastic LQFP (14 × 20)	Mounted	R5F100PF AFA, R5F100PG AFA, R5F100PH AFA, R5F100PJ AFA, R5F100PK AFA, R5F100PL AFA
		Not mounted	R5F101PF AFA, R5F101PG AFA, R5F101PH AFA, R5F101PJ AFA, R5F101PK AFA, R5F101PL AFA
128 pins	128-pin plastic LQFP (fine pitch) (14 × 20)	Mounted	R5F100SHAF B, R5F100SJAF B, R5F100SKAF B, R5F100SLAF B
		Not mounted	R5F101SHAF B, R5F101SJAF B, R5F101SKAF B, R5F101SLAF B



### 1.3 Pin Configuration (Top View)

#### 1.3.1 20-pin products

- 20-pin plastic SSOP (7.62 mm (300))

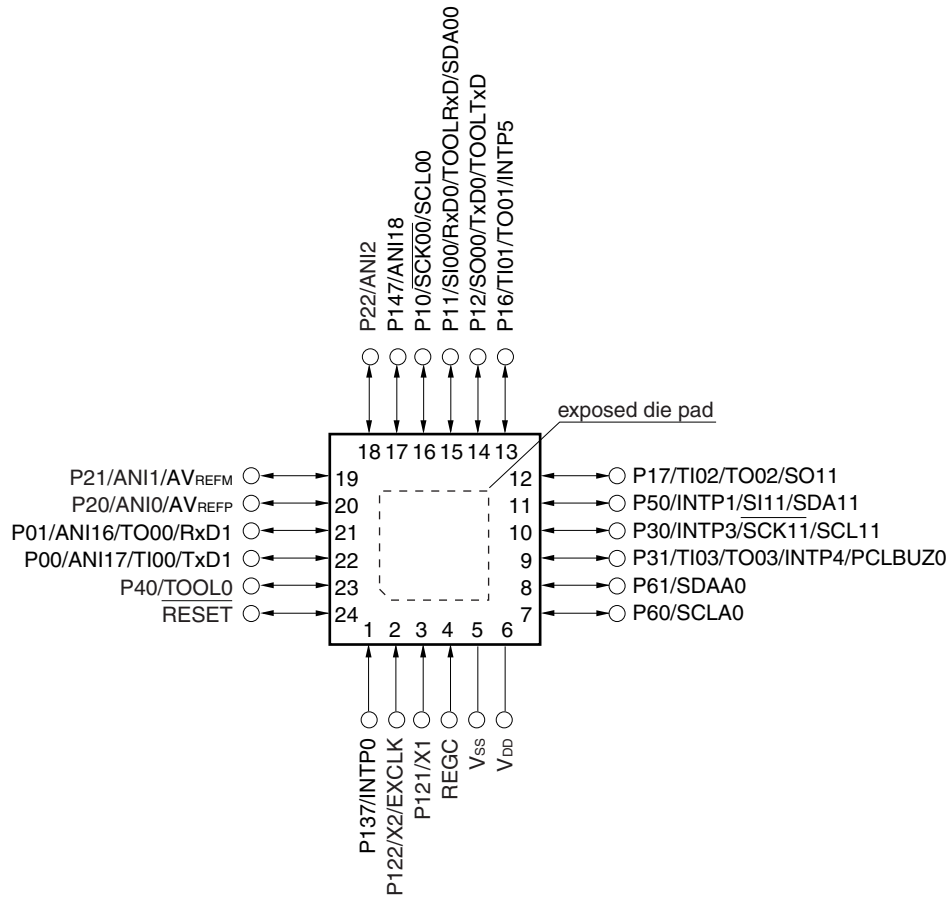


**Caution** Connect the REGC pin to V<sub>SS</sub> via a capacitor (0.47 to 1  $\mu$ F).

**Remark** For pin identification, see 1.4 Pin Identification.

1.3.2 24-pin products

- 24-pin plastic WQFN (fine pitch) (4 × 4)

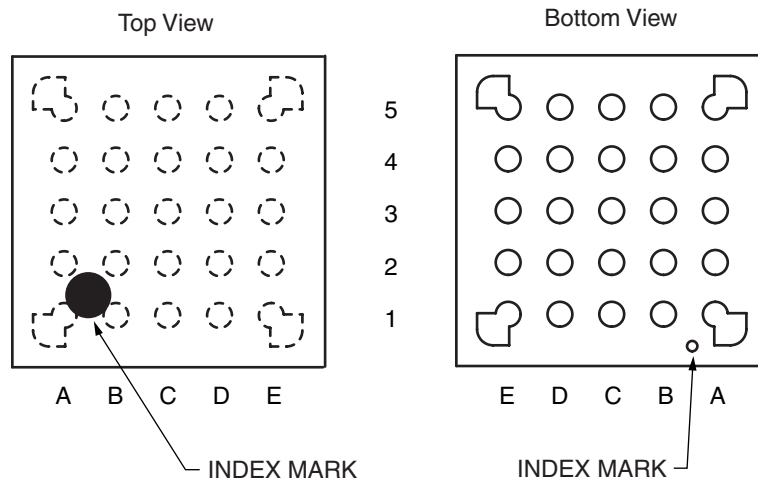


**Caution** Connect the REGC pin to Vss via a capacitor (0.47 to 1  $\mu$ F).

**Remark** For pin identification, see 1.4 Pin Identification.

1.3.3 25-pin products

- 25-pin plastic FLGA (3 × 3)



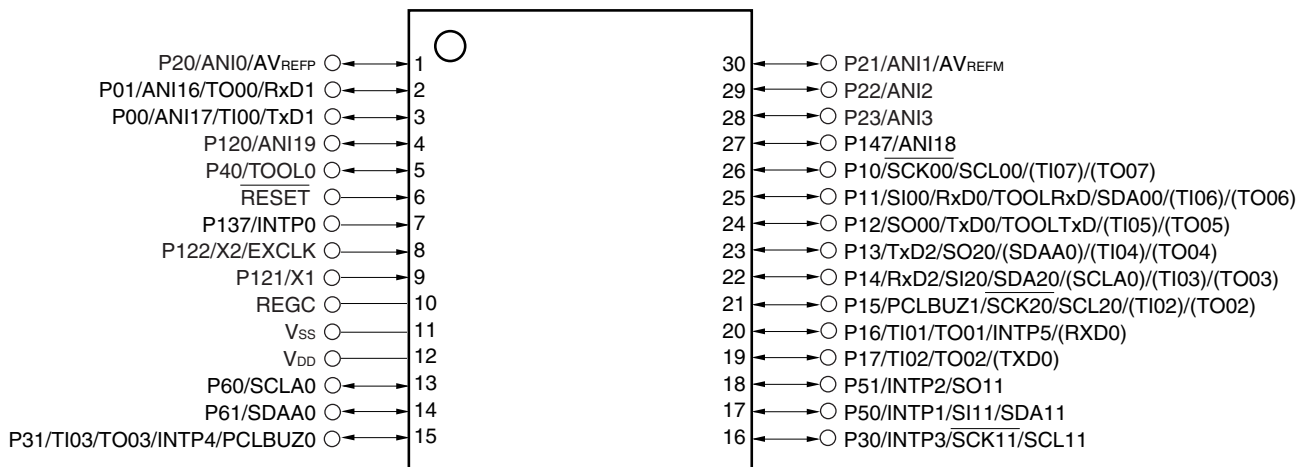
	A	B	C	D	E	
5	P40/TOOL0	RESET	P01/ANI16/ TO00/RxD1	P22/ANI2	P147/ANI18	5
4	P122/X2/ EXCLK	P137/INTP0	P00/ANI17/ TI00/TxD1	P21/ANI1/ AVREFM	P10/SCK00/ SCL00	4
3	P121/X1	V <sub>DD</sub>	P20/ANI0/ AVREFP	P12/SO00/ TxD0/ TOOLTxD	P11/SI00/ RxD0/ TOOLRxD/ SDA00	3
2	REGC	V <sub>SS</sub>	P30/INTP3/ SCK11/SCL11	P17/TI02/ TO02/SO11	P50/INTP1/ SI11/SDA11	2
1	P60/SCLA0	P61/SDAA0	P31/TI03/ TO03/INTP4/ PCLBUZ0	P16/TI01/ TO01/INTP5	P130	1
	A	B	C	D	E	

**Caution** Connect the REGC pin to V<sub>SS</sub> via a capacitor (0.47 to 1 μF).

**Remark** For pin identification, see 1.4 Pin Identification.

### 1.3.4 30-pin products

- <R> • 30-pin plastic SSOP (7.62 mm (300))



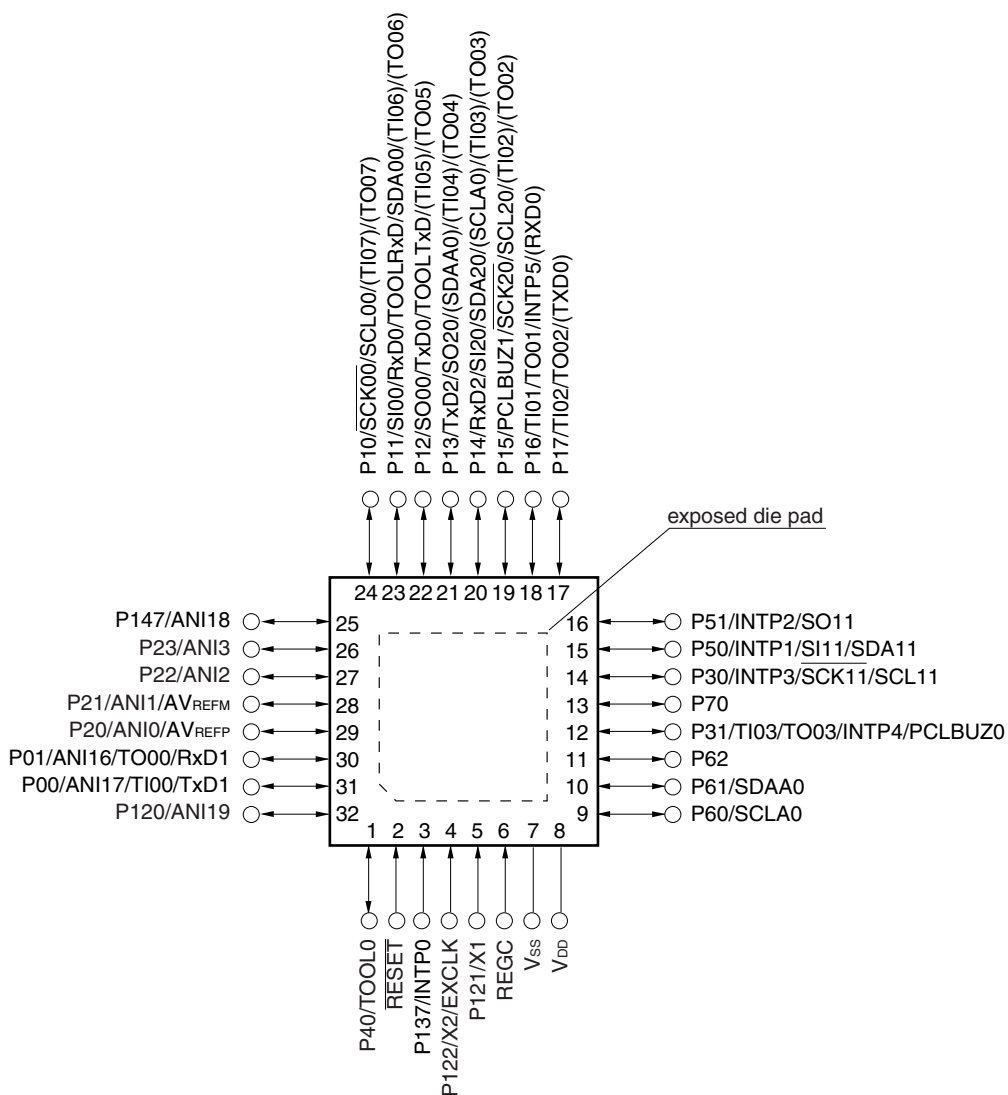
**Caution** Connect the REGC pin to V<sub>SS</sub> via a capacitor (0.47 to 1  $\mu$ F).

**Remarks 1.** For pin identification, see 1.4 Pin Identification.

- Functions in parentheses in the above figure can be assigned via settings in the peripheral I/O redirection register (PIOR).

1.3.5 32-pin products

- 32-pin plastic WQFN (fine pitch) (5 × 5)



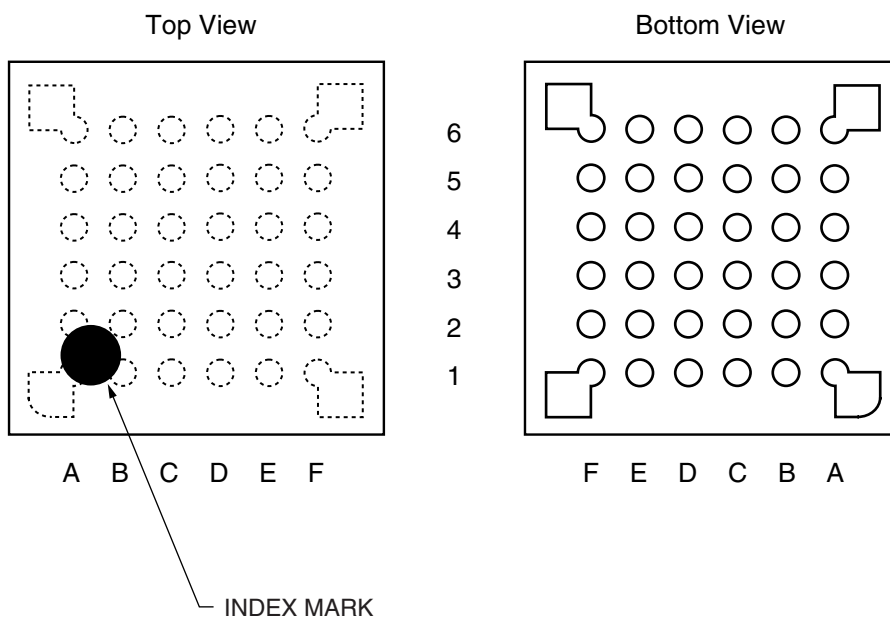
**Caution** Connect the REGC pin to Vss via a capacitor (0.47 to 1 μF).

**Remarks 1.** For pin identification, see 1.4 Pin Identification.

2. Functions in parentheses in the above figure can be assigned via settings in the peripheral I/O redirection register (PIOR).

1.3.6 36-pin products

- 36-pin plastic FLGA (4 × 4)



	A	B	C	D	E	F	
6	P60/SCLA0	V <sub>DD</sub>	P121/X1	P122/X2/EXCLK	P137/INTP0	P40/TOOL0	6
5	P62	P61/SDAA0	V <sub>SS</sub>	REGC	RESET	P120/ANI19	5
4	P72/SO21	P71/SI21/ SDA21	P14/RxD2/SI20/ SDA20/(SCLA0) /(TI03)/(TO03)	P31/TI03/TO03/ INTP4/ PCLBUZ0	P00/TI00/TxD1	P01/TO00/RxD1	4
3	P50/INTP1/ SI11/SDA11	P70/SCK21/ SCL21	P15/PCLBUZ1/ SCK20/SCL20/ (TI02)/(TO02)	P22/ANI2	P20/ANI0/ AV <sub>REFP</sub>	P21/ANI1/ AV <sub>REFM</sub>	3
2	P30/INTP3/ SCK11/SCL11	P16/TI01/TO01/ INTP5/(RxD0)	P12/SO00/ TxD0/TOOLTxD /(TI05)/(TO05)	P11/SI00/RxD0/ TOOLRxD/ SDA00/(TI06)/ (TO06)	P24/ANI4	P23/ANI3	2
1	P51/INTP2/ SO11	P17/TI02/TO02/ (TxD0)	P13/TxD2/ SO20/(SDAA0)/ (TI04)/(TO04)	P10/SCK00/ SCL00/(TI07)/ (TO07)	P147/ANI18	P25/ANI5	1
	A	B	C	D	E	F	

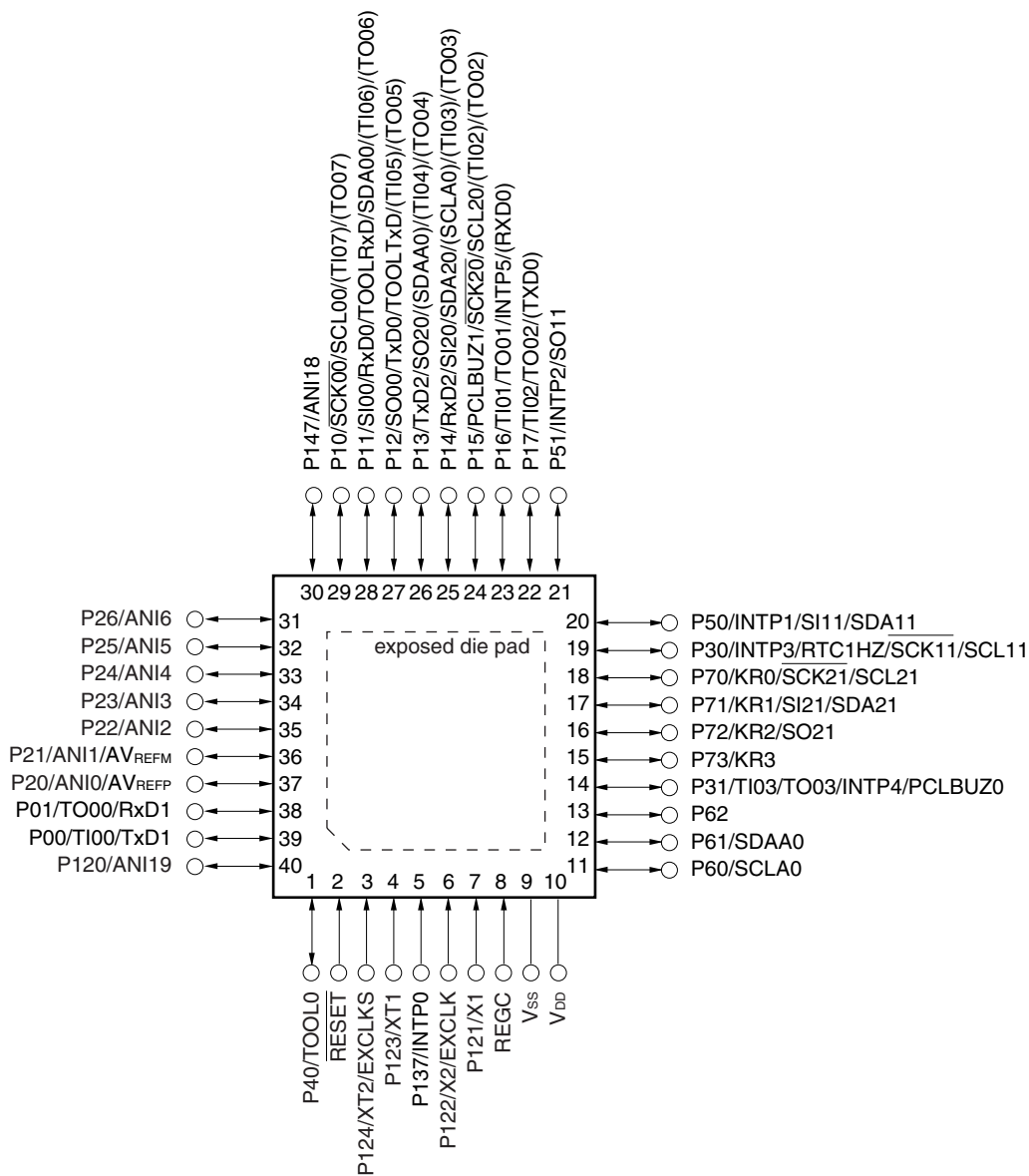
**Caution** Connect the REGC pin to V<sub>SS</sub> via a capacitor (0.47 to 1 μF).

**Remarks 1.** For pin identification, see 1.4 Pin Identification.

2. Functions in parentheses in the above figure can be assigned via settings in the peripheral I/O redirection register (PIOR).

1.3.7 40-pin products

- <R> • 40-pin plastic WQFN (fine pitch) (6 × 6)

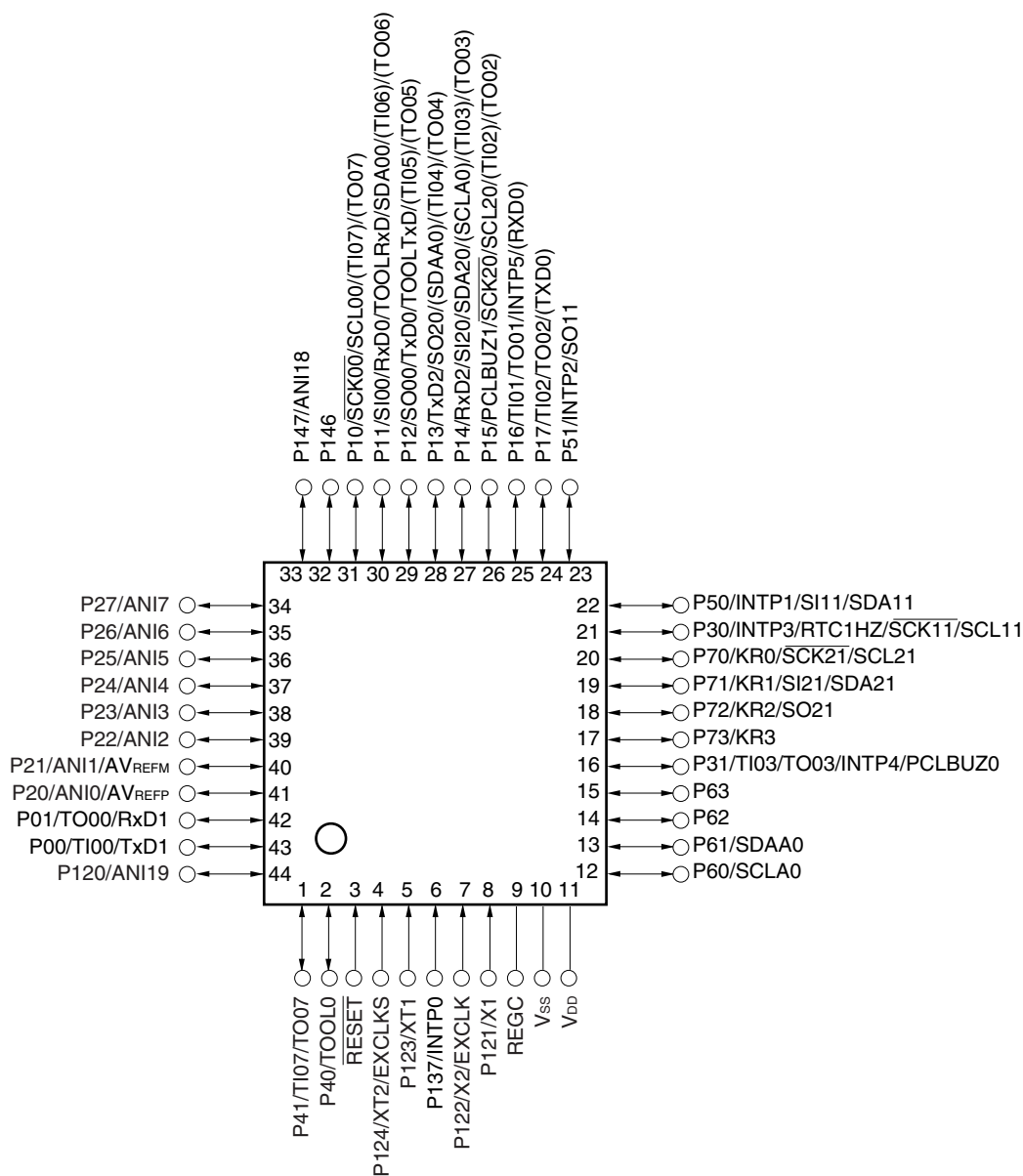


**Caution** Connect the REGC pin to V<sub>SS</sub> via a capacitor (0.47 to 1 μF).

- Remarks 1.** For pin identification, see 1.4 Pin Identification.
- 2.** Functions in parentheses in the above figure can be assigned via settings in the peripheral I/O redirection register (PIOR).

1.3.8 44-pin products

- <R> • 44-pin plastic LQFP (10 × 10)



**Caution** Connect the REGC pin to Vss via a capacitor (0.47 to 1 μF).

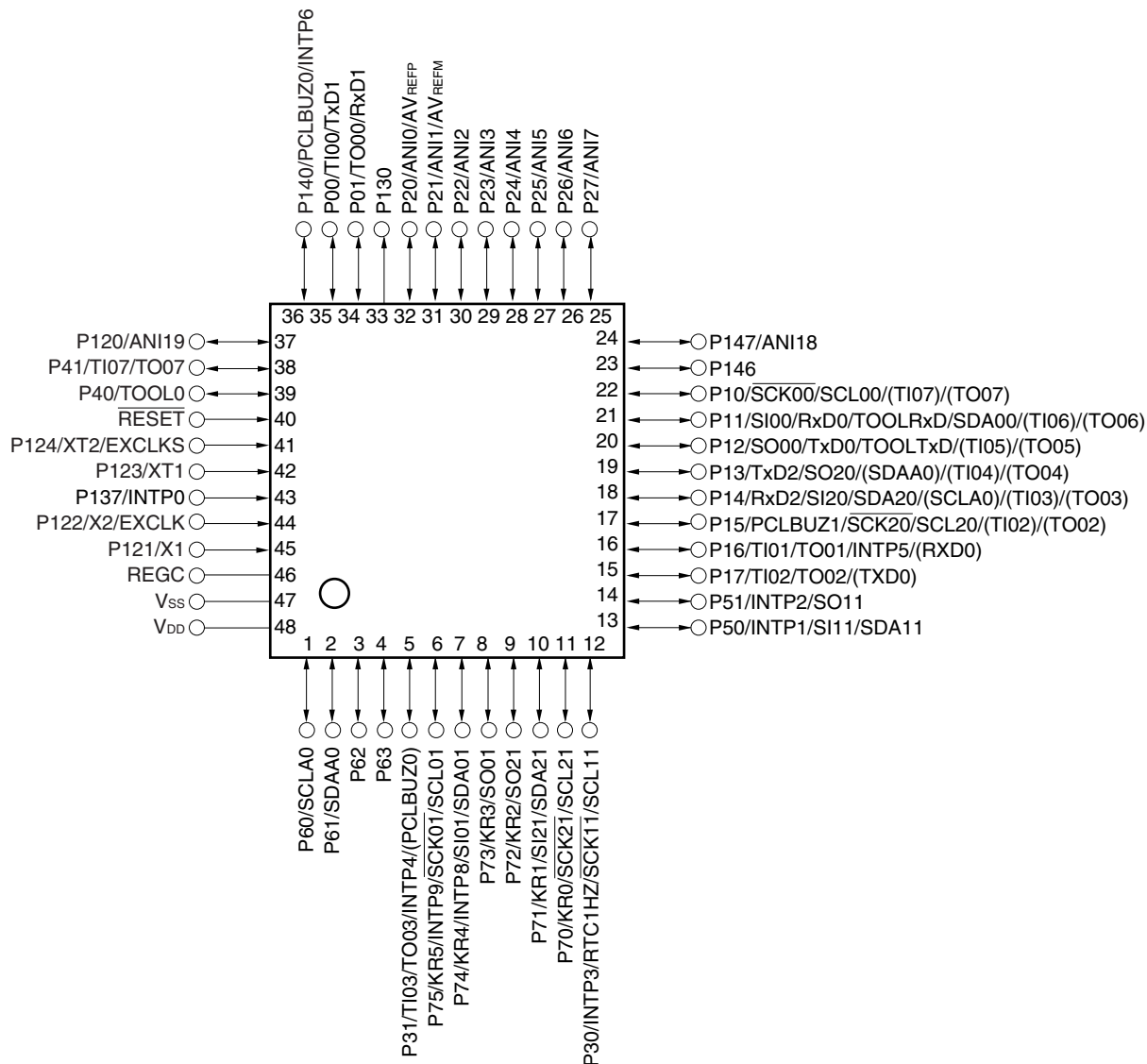
**Remarks 1.** For pin identification, see 1.4 Pin Identification.

- Functions in parentheses in the above figure can be assigned via settings in the peripheral I/O redirection register (PIOR).



1.3.9 48-pin products

- <R> • 48-pin plastic LQFP (fine pitch) (7 × 7)

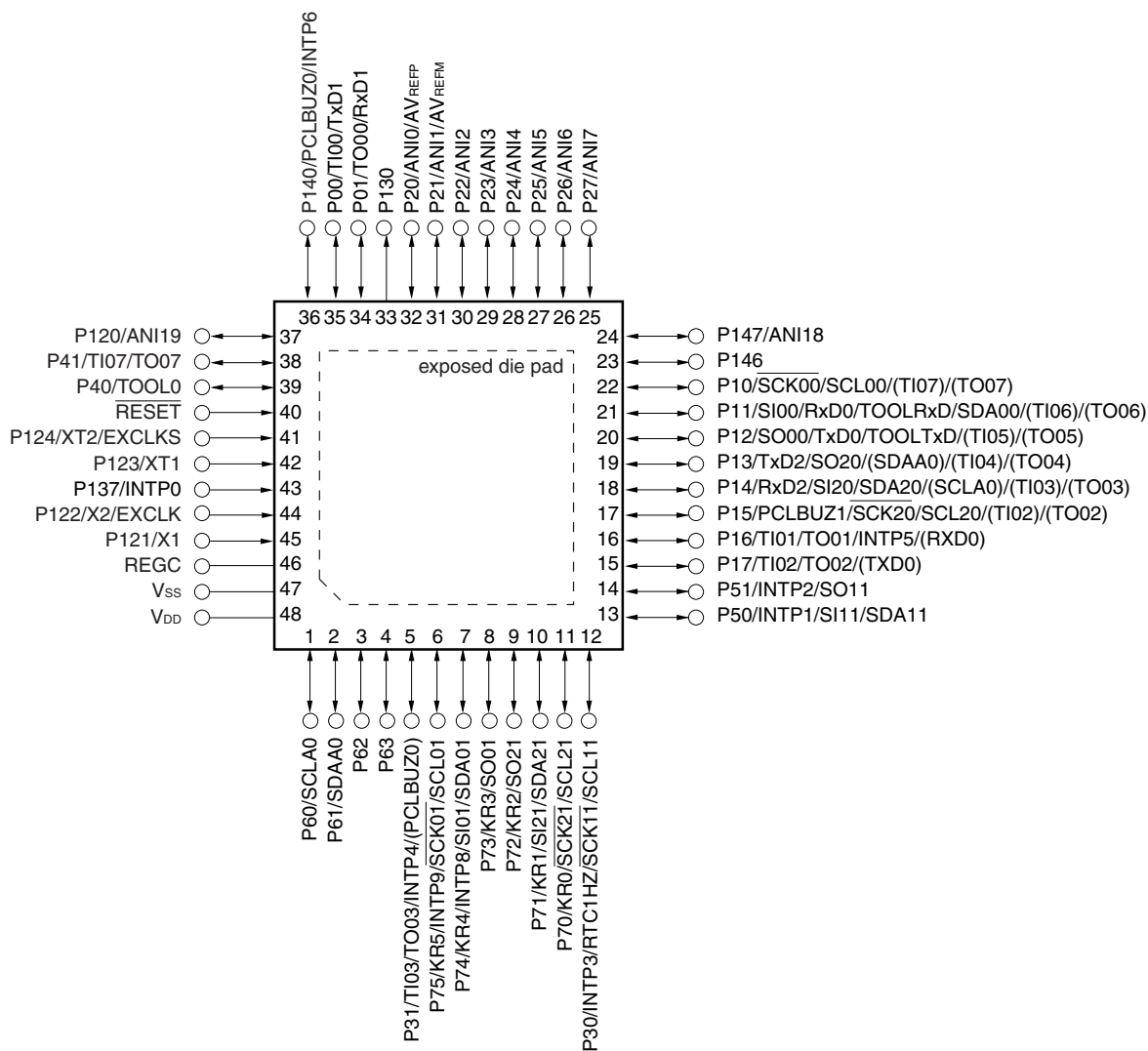


**Caution** Connect the REGC pin to Vss via a capacitor (0.47 to 1  $\mu$ F).

**Remarks 1.** For pin identification, see 1.4 Pin Identification.

- Functions in parentheses in the above figure can be assigned via settings in the peripheral I/O redirection register (PIOR).

<R> • 48-pin plastic WQFN (7 × 7)



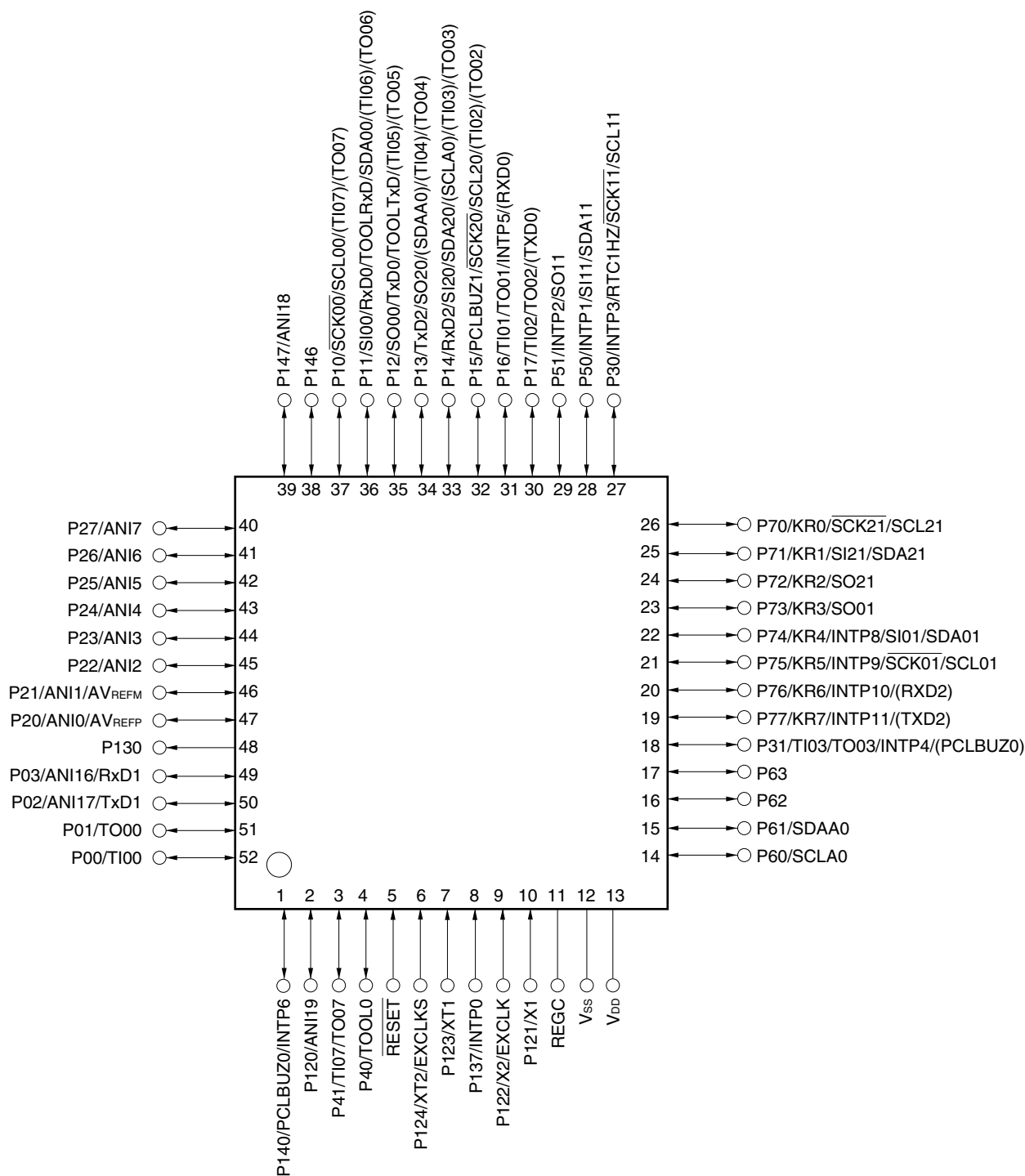
**Caution** Connect the REGC pin to Vss via a capacitor (0.47 to 1  $\mu$ F).

**Remarks 1.** For pin identification, see 1.4 Pin Identification.

**2.** Functions in parentheses in the above figure can be assigned via settings in the peripheral I/O redirection register (PIOR).

1.3.10 52-pin products

- <R> • 52-pin plastic LQFP (10 × 10)



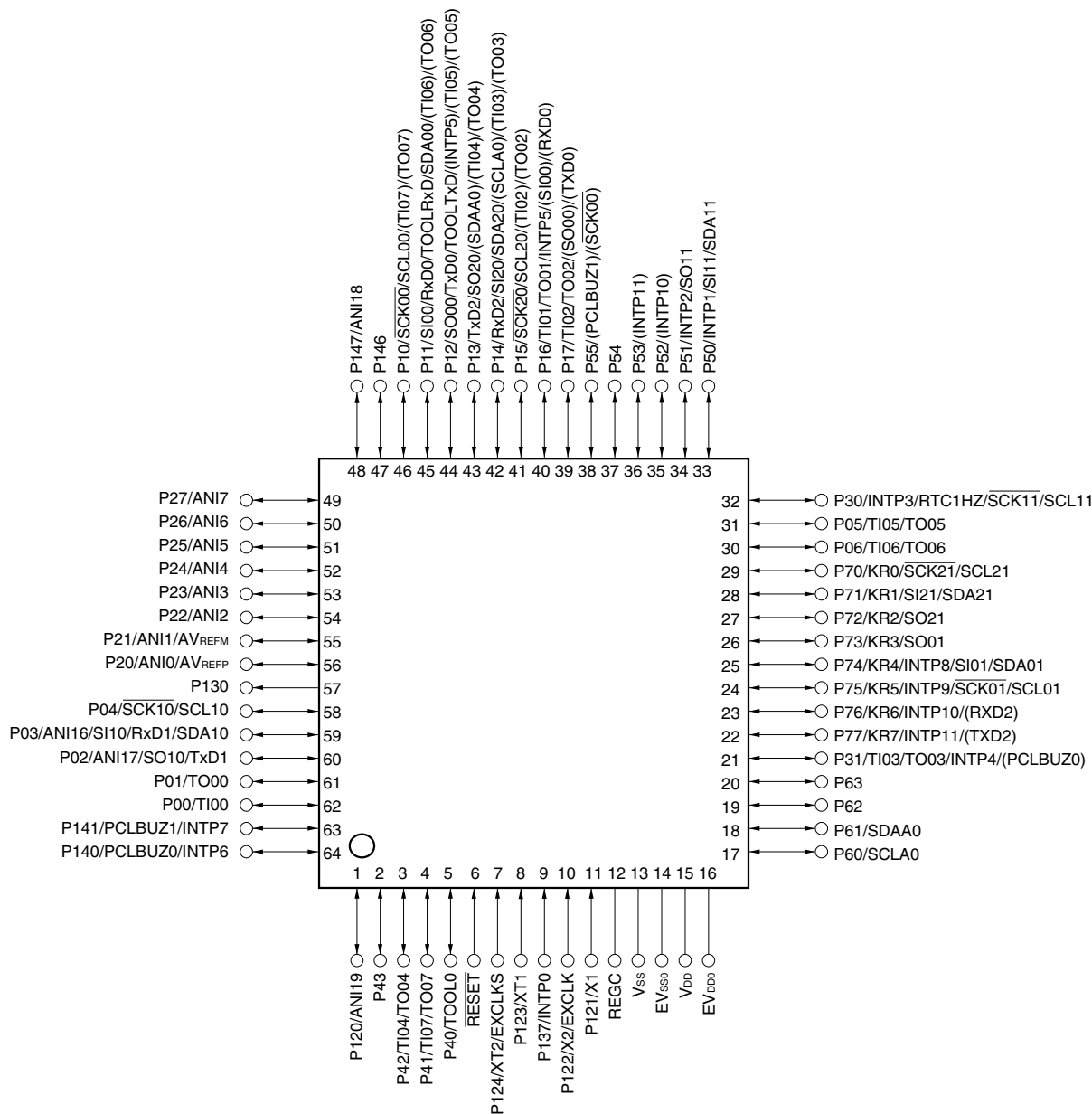
**Caution** Connect the REGC pin to Vss via a capacitor (0.47 to 1 μF).

**Remarks 1.** For pin identification, see 1.4 Pin Identification.

- Functions in parentheses in the above figure can be assigned via settings in the peripheral I/O redirection register (PIOR).

1.3.11 64-pin products

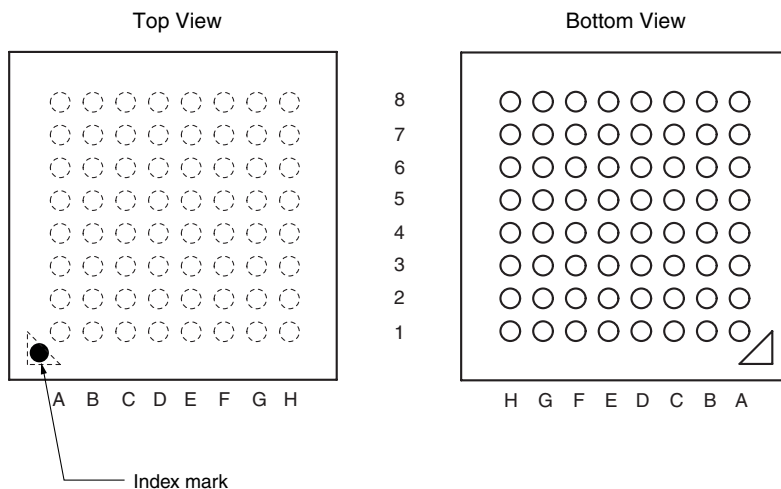
- <R> • 64-pin plastic LQFP (12 × 12)
- 64-pin plastic LQFP (fine pitch) (10 × 10)
- 64-pin plastic TQFP (fine pitch) (7 × 7)



- Cautions**
1. Make EV<sub>ss0</sub> pin the same potential as V<sub>ss</sub> pin.
  2. Make V<sub>DD</sub> pin the potential that is higher than EV<sub>DD0</sub> pin.
  3. Connect the REGC pin to V<sub>ss</sub> via a capacitor (0.47 to 1 μF).

- Remarks**
1. For pin identification, see 1.4 Pin Identification.
  2. When using the microcontroller for an application where the noise generated inside the microcontroller must be reduced, it is recommended to supply separate powers to the V<sub>DD</sub> and EV<sub>DD0</sub> pins and connect the V<sub>ss</sub> and EV<sub>ss0</sub> pins to separate ground lines.
  3. Functions in parentheses in the above figure can be assigned via settings in the peripheral I/O redirection register (PIOR).

<R> • 64-pin plastic FBGA (4 × 4)



Pin No.	Name	Pin No.	Name	Pin No.	Name	Pin No.	Name
A1	P05/TI05/TO05	C1	P51/INTP2/SO11	E1	P13/TxD2/SO20/ (SDAA0)/(TI04)/(TO04)	G1	P146
A2	P30/INTP3/RTC1HZ /SCK17/SCL11	C2	P71/KR1/SI21/SDA21	E2	P14/RxD2/SI20/SDA20 /(SCLA0)/(TI03)/(TO03)	G2	P25/ANI5
A3	P70/KR0/SCK21 /SCL21	C3	P74/KR4/INTP8/SI01 /SDA01	E3	P15/SCK20/SCL20/ (TI02)/(TO02)	G3	P24/ANI4
A4	P75/KR5/INTP9 /SCK07/SCL01	C4	P52/(INTP10)	E4	P16/TI01/TO01/INTP5 /(SI00)/(RxD0)	G4	P22/ANI2
A5	P77/KR7/INTP11/ (TxD2)	C5	P53/(INTP11)	E5	P03/ANI16/SI10/RxD1 /SDA10	G5	P130
A6	P61/SDAA0	C6	P63	E6	P41/TI07/TO07	G6	P02/ANI17/SO10/TxD1
A7	P60/SCLA0	C7	V <sub>SS</sub>	E7	RESET	G7	P00/TI00
A8	EV <sub>DD0</sub>	C8	P121/X1	E8	P137/INTP0	G8	P124/XT2/EXCLKS
B1	P50/INTP1/SI11 /SDA11	D1	P55/(PCLBUZ1)/ (SCK00)	F1	P10/SCK00/SCL00/ (TI07)/(TO07)	H1	P147/ANI18
B2	P72/KR2/SO21	D2	P06/TI06/TO06	F2	P11/SI00/RxD0 /TOOLRxD/SDA00/ (TI06)/(TO06)	H2	P27/ANI7
B3	P73/KR3/SO01	D3	P17/TI02/TO02/ (SO00)/(TxD0)	F3	P12/SO00/TxD0 /TOOLTxD/(INTP5)/ (TI05)/(TO05)	H3	P26/ANI6
B4	P76/KR6/INTP10/ (RxD2)	D4	P54	F4	P21/ANI1/AV <sub>REFM</sub>	H4	P23/ANI3
B5	P31/TI03/TO03 /INTP4/(PCLBUZ0)	D5	P42/TI04/TO04	F5	P04/SCK10/SCL10	H5	P20/ANI0/AV <sub>REFP</sub>
B6	P62	D6	P40/TOOL0	F6	P43	H6	P141/PCLBUZ1/INTP7
B7	V <sub>DD</sub>	D7	REGC	F7	P01/TO00	H7	P140/PCLBUZ0/INTP6
B8	EV <sub>SS0</sub>	D8	P122/X2/EXCLK	F8	P123/XT1	H8	P120/ANI19

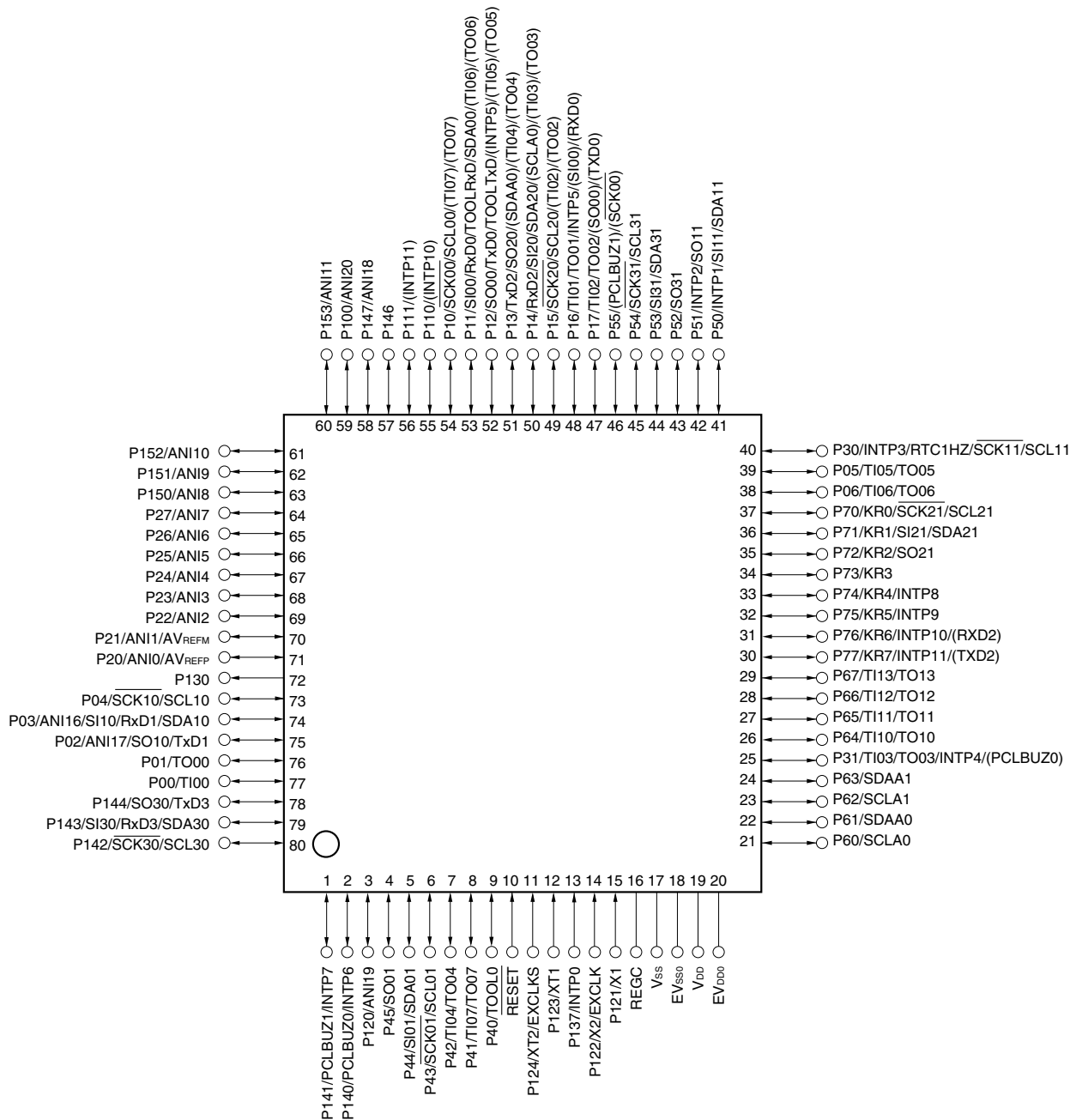
- Cautions**
1. Make EV<sub>SS0</sub> pin the same potential as V<sub>SS</sub> pin.
  2. Make V<sub>DD</sub> pin the potential that is higher than EV<sub>DD0</sub> pin.
  3. Connect the REGC pin to V<sub>SS</sub> via a capacitor (0.47 to 1 μF).

**Remarks** 1. For pin identification, see 1.4 Pin Identification.

2. When using the microcontroller for an application where the noise generated inside the microcontroller must be reduced, it is recommended to supply separate powers to the V<sub>DD</sub> and EV<sub>DD0</sub> pins and connect the V<sub>SS</sub> and EV<sub>SS0</sub> pins to separate ground lines.
3. Functions in parentheses in the above figure can be assigned via settings in the peripheral I/O redirection register (PIOR).

1.3.12 80-pin products

- <R> • 80-pin plastic LQFP (14 × 14)
- 80-pin plastic LQFP (fine pitch) (12 × 12)

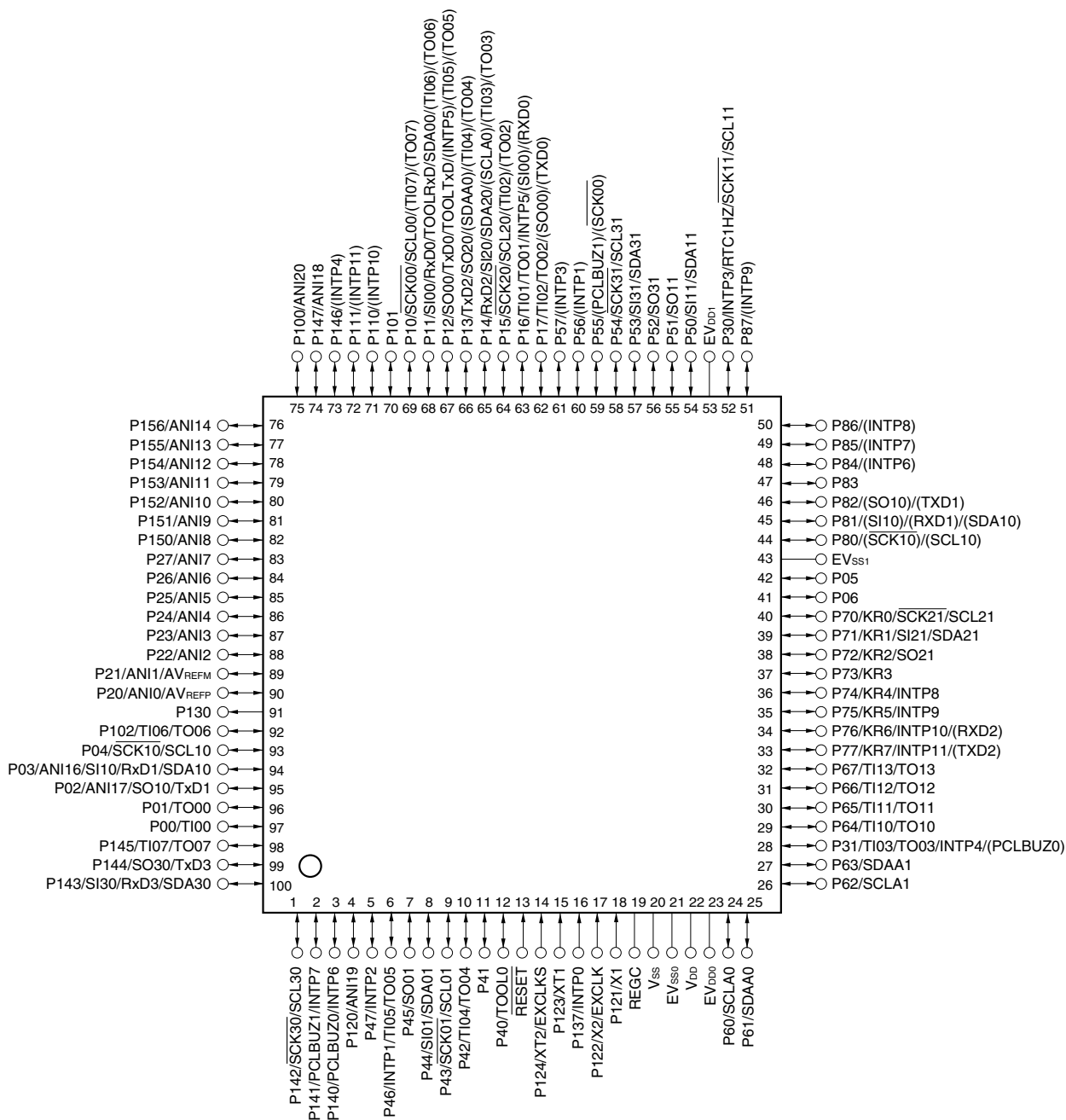


- Cautions**
1. Make EV<sub>SS0</sub> pin the same potential as V<sub>SS</sub> pin.
  2. Make V<sub>DD</sub> pin the potential that is higher than EV<sub>DD0</sub> pin.
  3. Connect the REGC pin to V<sub>SS</sub> via a capacitor (0.47 to 1 μF).

- Remarks**
1. For pin identification, see 1.4 Pin Identification.
  2. When using the microcontroller for an application where the noise generated inside the microcontroller must be reduced, it is recommended to supply separate powers to the V<sub>DD</sub> and EV<sub>DD0</sub> pins and connect the V<sub>SS</sub> and EV<sub>SS0</sub> pins to separate ground lines.
  3. Functions in parentheses in the above figure can be assigned via settings in the peripheral I/O redirection register (PIOR).

1.3.13 100-pin products

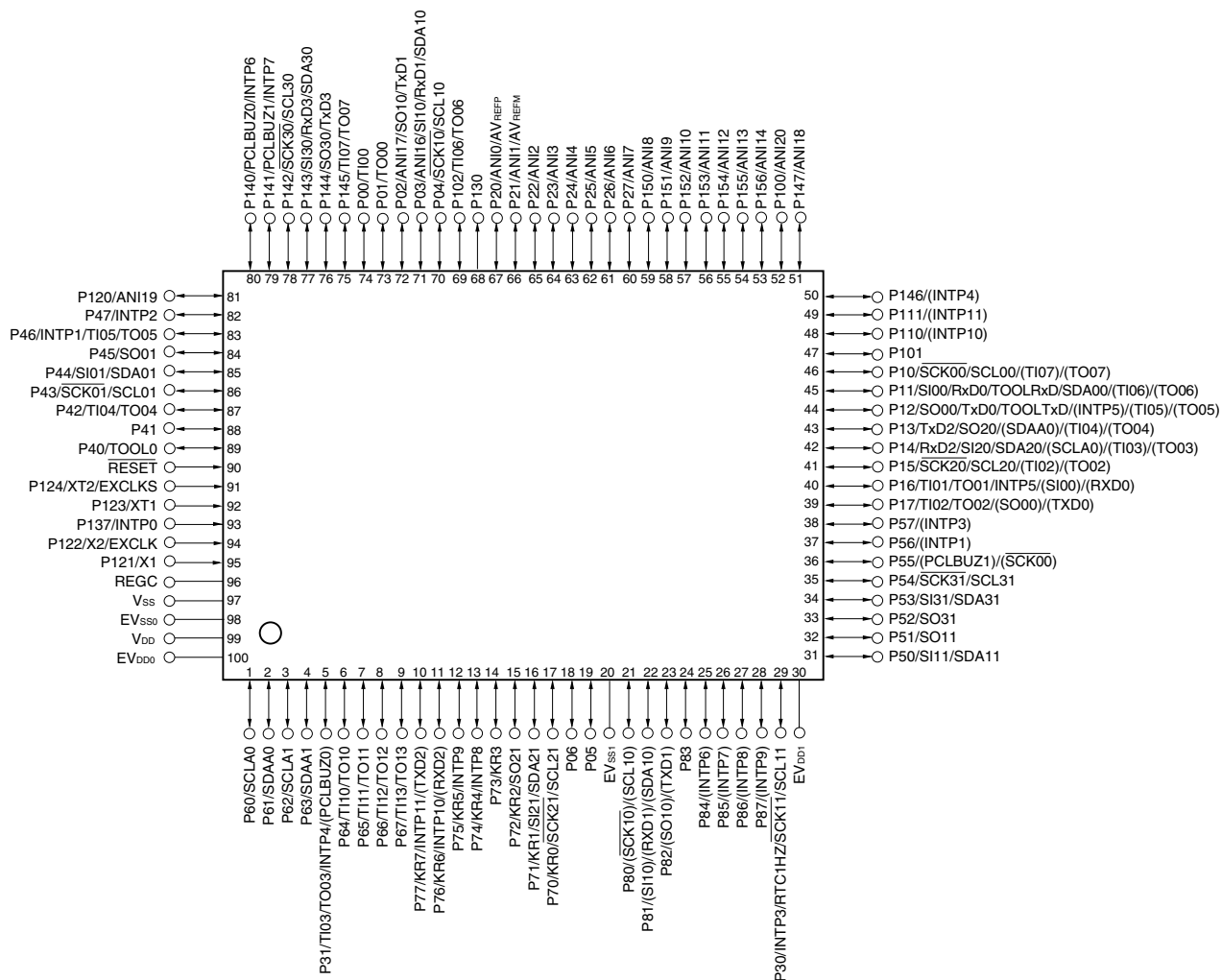
- <R> • 100-pin plastic LQFP (fine pitch) (14 × 14)



- Cautions**
1. Make EV<sub>SS0</sub>, EV<sub>SS1</sub> pins the same potential as V<sub>SS</sub> pin.
  2. Make V<sub>DD</sub> pin the potential that is higher than EV<sub>DD0</sub>, EV<sub>DD1</sub> pins (EV<sub>DD0</sub> = EV<sub>DD1</sub>).
  3. Connect the REGC pin to V<sub>SS</sub> via a capacitor (0.47 to 1 μF).

- Remarks**
1. For pin identification, see 1.4 Pin Identification.
  2. When using the microcontroller for an application where the noise generated inside the microcontroller must be reduced, it is recommended to supply separate powers to the V<sub>DD</sub>, EV<sub>DD0</sub> and EV<sub>DD1</sub> pins and connect the V<sub>SS</sub>, EV<sub>SS0</sub> and EV<sub>SS1</sub> pins to separate ground lines.
  3. Functions in parentheses in the above figure can be assigned via settings in the peripheral I/O redirection register (PIOR).

<R> • 100-pin plastic LQFP (14 × 20)



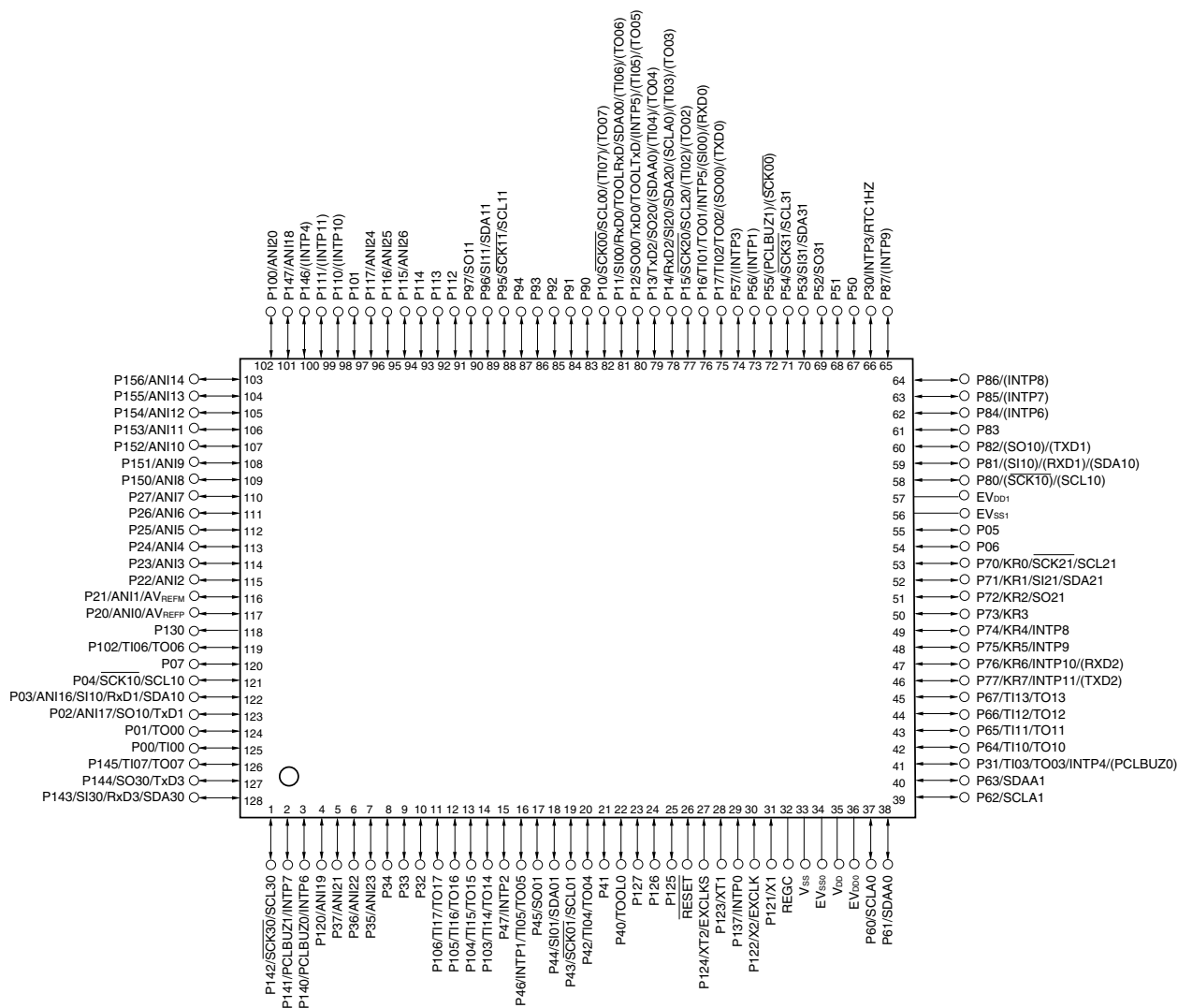
- Cautions**
1. Make EV<sub>SS0</sub>, EV<sub>SS1</sub> pins the same potential as V<sub>SS</sub> pin.
  2. Make V<sub>DD</sub> pin the potential that is higher than EV<sub>DD0</sub>, EV<sub>DD1</sub> pins (EV<sub>DD0</sub> = EV<sub>DD1</sub>).
  3. Connect the REGC pin to V<sub>SS</sub> via a capacitor (0.47 to 1 μF).

- Remarks**
1. For pin identification, see 1.4 Pin Identification.
  2. When using the microcontroller for an application where the noise generated inside the microcontroller must be reduced, it is recommended to supply separate powers to the V<sub>DD</sub>, EV<sub>DD0</sub> and EV<sub>DD1</sub> pins and connect the V<sub>SS</sub>, EV<sub>SS0</sub> and EV<sub>SS1</sub> pins to separate ground lines.
  3. Functions in parentheses in the above figure can be assigned via settings in the peripheral I/O redirection register (PIOR).



1.3.14 128-pin products

- <R> • 128-pin plastic LQFP (fine pitch) (14 × 20)



- Cautions**
1. Make EV<sub>SS0</sub>, EV<sub>SS1</sub> pins the same potential as V<sub>SS</sub> pin.
  2. Make V<sub>DD</sub> pin the potential that is higher than EV<sub>DD0</sub>, EV<sub>DD1</sub> pins (EV<sub>DD0</sub> = EV<sub>DD1</sub>).
  3. Connect the REGC pin to V<sub>SS</sub> via a capacitor (0.47 to 1 μF).

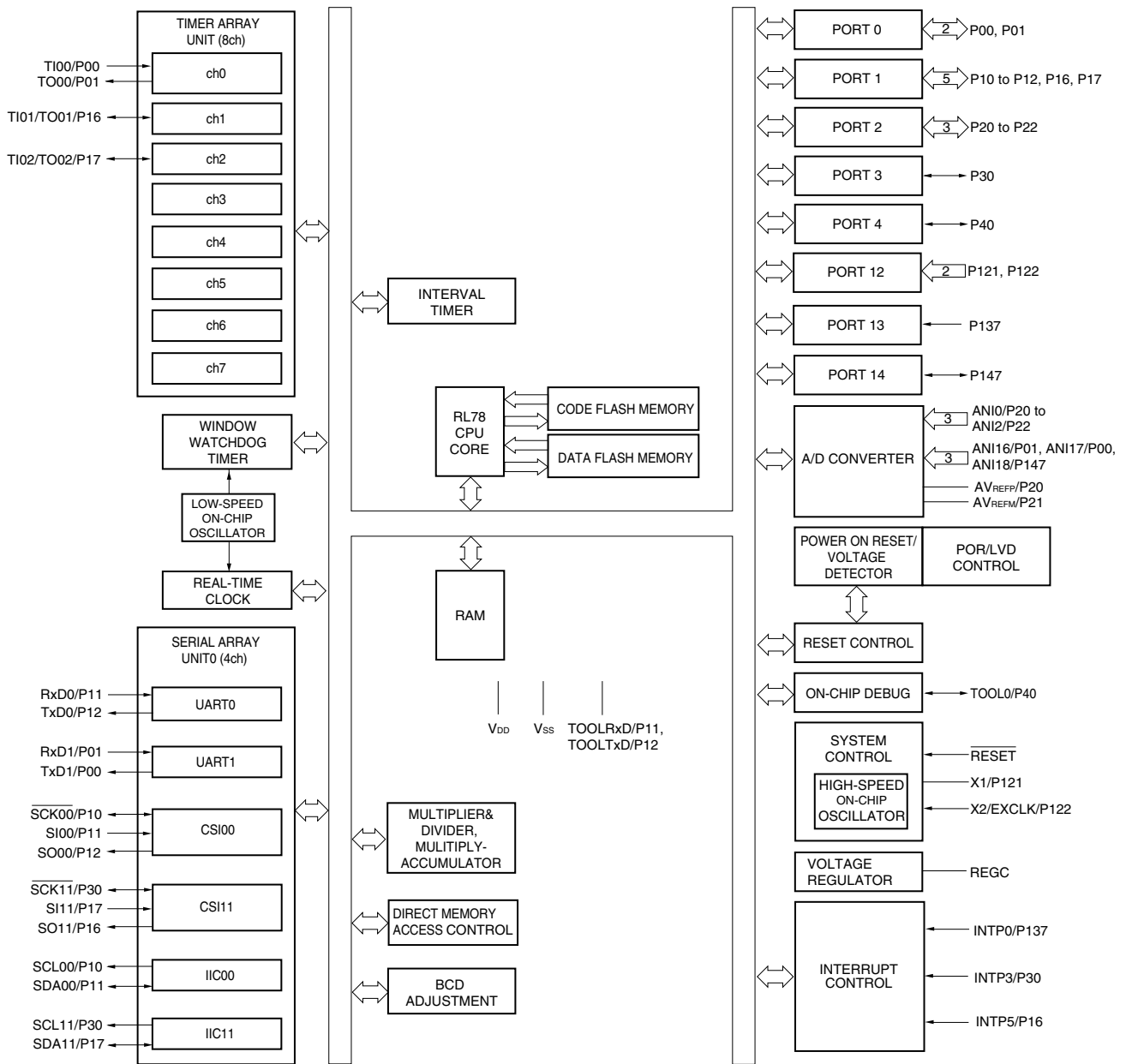
- Remarks**
1. For pin identification, see 1.4 Pin Identification.
  2. When using the microcontroller for an application where the noise generated inside the microcontroller must be reduced, it is recommended to supply separate powers to the V<sub>DD</sub>, EV<sub>DD0</sub> and EV<sub>DD1</sub> pins and connect the V<sub>SS</sub>, EV<sub>SS0</sub> and EV<sub>SS1</sub> pins to separate ground lines.
  3. Functions in parentheses in the above figure can be assigned via settings in the peripheral I/O redirection register (PIOR).

## 1.4 Pin Identification

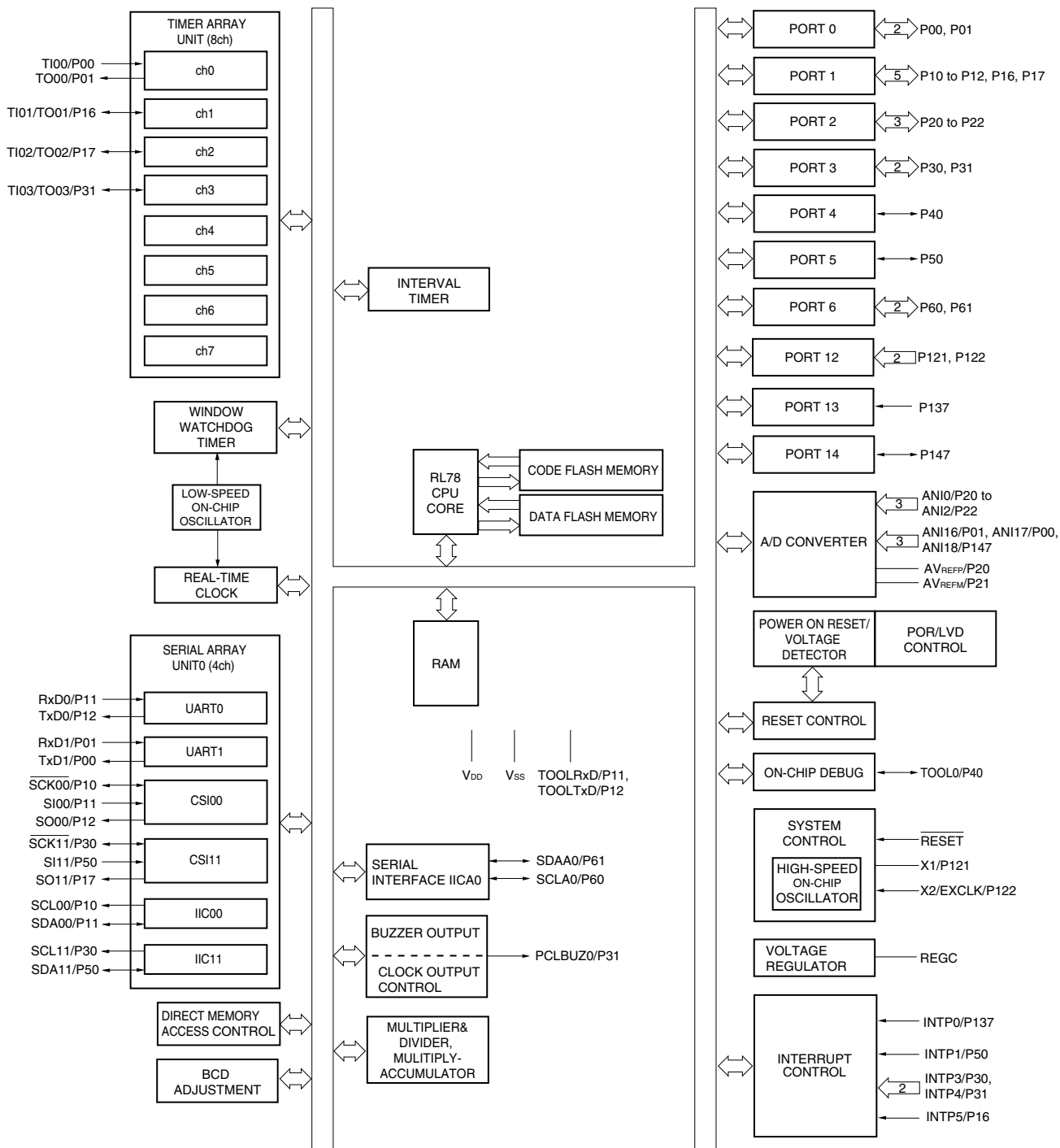
ANI0 to ANI14,		PCLBUZ0, PCLBUZ1:	Programmable clock output/buzzer output
ANI16 to ANI26:	Analog input	REGC:	Regulator capacitance
AVREFM:	A/D converter reference potential (– side) input	RESET:	Reset
AVREFP:	A/D converter reference potential (+ side) input	RTC1HZ:	Real-time clock correction clock (1 Hz) output
EVDD0, EVDD1:	Power supply for port	RxD0 to RxD3:	Receive data
EVSS0, EVSS1:	Ground for port	SCK00, SCK01, SCK10, SCK11, SCK20, SCK21, SCK30, SCK31:	Serial clock input/output
EXCLK:	External clock input (main system clock)	SCLA0, SCLA1, SCL00, SCL01, SCL10, SCL11, SCL20, SCL21, SCL30, SCL31:	Serial clock input/output
EXCLKS:	External clock input (sub system clock)	SDAA0, SDAA1, SDA00, SDA01, SDA10, SDA11, SDA20, SDA21, SDA30, SDA31:	Serial data input/output
INTP0 to INTP11:	External interrupt input	SI00, SI01, SI10, SI11, SI20, SI21, SI30, SI31:	Serial data input
KR0 to KR7:	Key return	SO00, SO01, SO10, SO11, SO20, SO21, SO30, SO31:	Serial data output
P00 to P07:	Port 0	TI00 to TI07,	
P10 to P17:	Port 1	TI10 to TI17:	Timer input
P20 to P27:	Port 2	TO00 to TO07,	
P30 to P37:	Port 3	TO10 to TO17:	Timer output
P40 to P47:	Port 4	TOOL0:	Data input/output for tool
P50 to P57:	Port 5	TOOLRxD, TOOLTxD:	Data input/output for external device
P60 to P67:	Port 6	TxD0 to TxD3:	Transmit data
P70 to P77:	Port 7	V <sub>DD</sub> :	Power supply
P80 to P87:	Port 8	V <sub>SS</sub> :	Ground
P90 to P97:	Port 9	X1, X2:	Crystal oscillator (main system clock)
P100 to P106:	Port 10	XT1, XT2:	Crystal oscillator (subsystem clock)
P110 to P117:	Port 11		
P120 to P127:	Port 12		
P130, P137:	Port 13		
P140 to P147:	Port 14		
P150 to P156:	Port 15		

### 1.5 Block Diagram

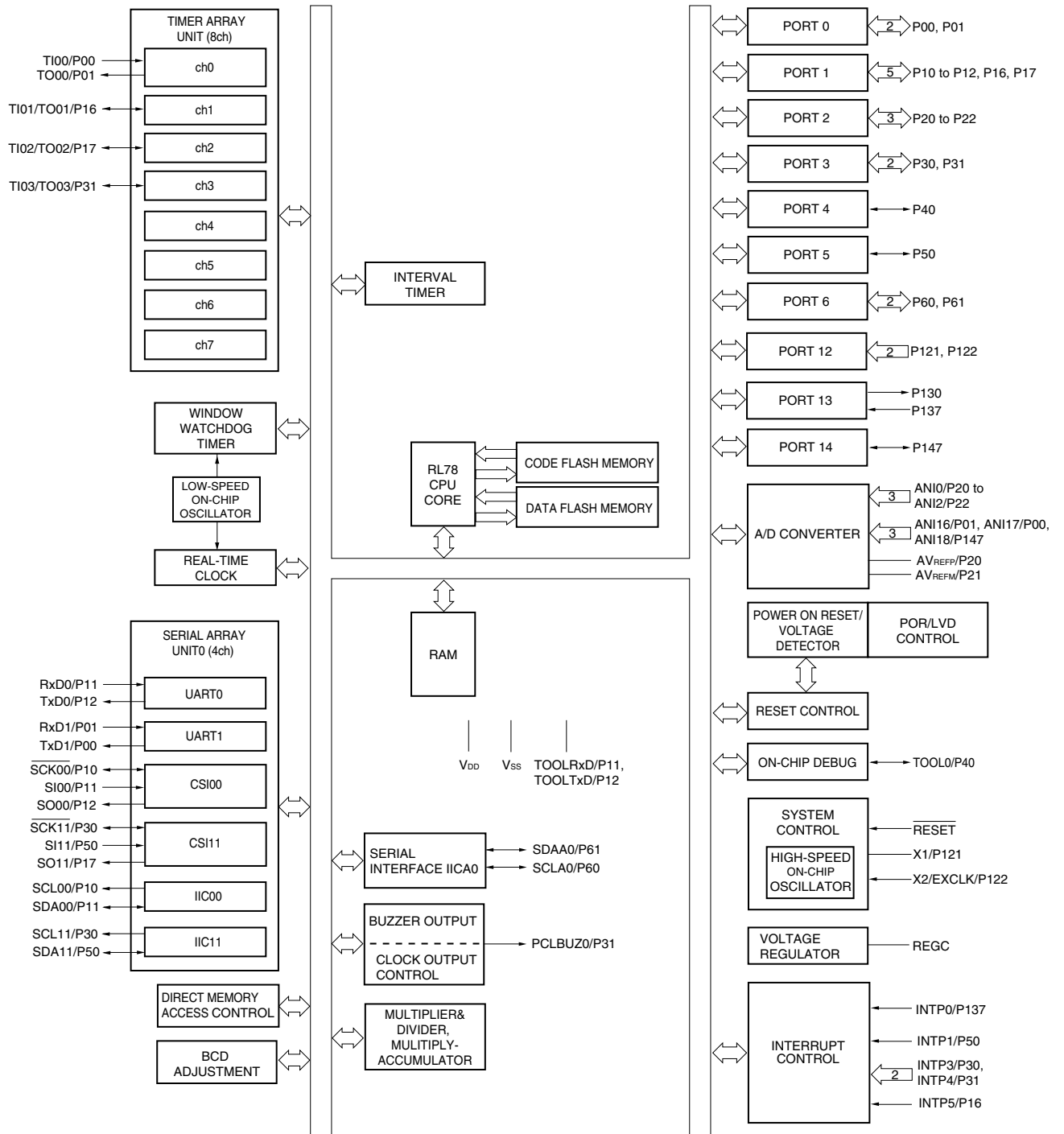
#### 1.5.1 20-pin products



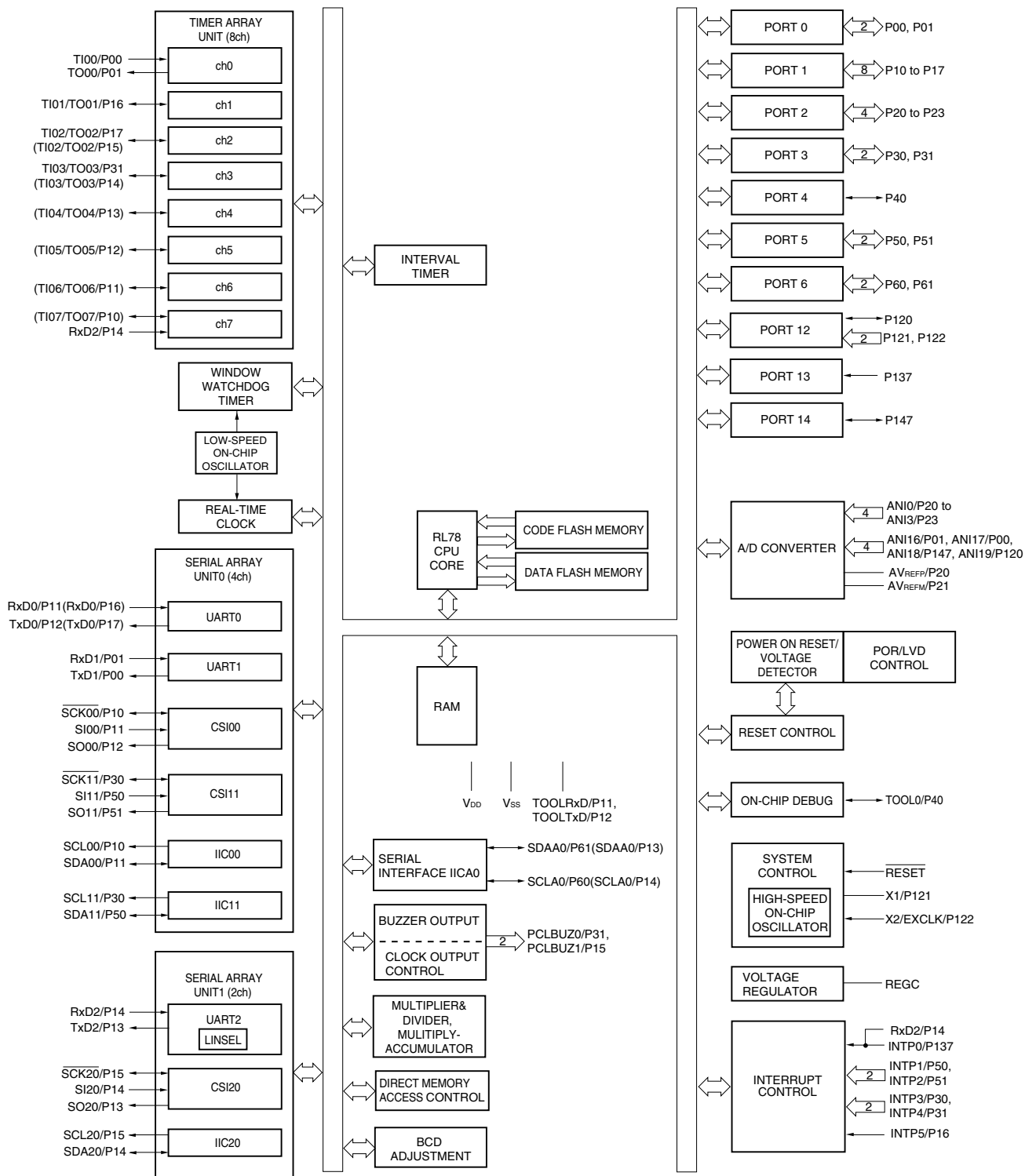
1.5.2 24-pin products



1.5.3 25-pin products

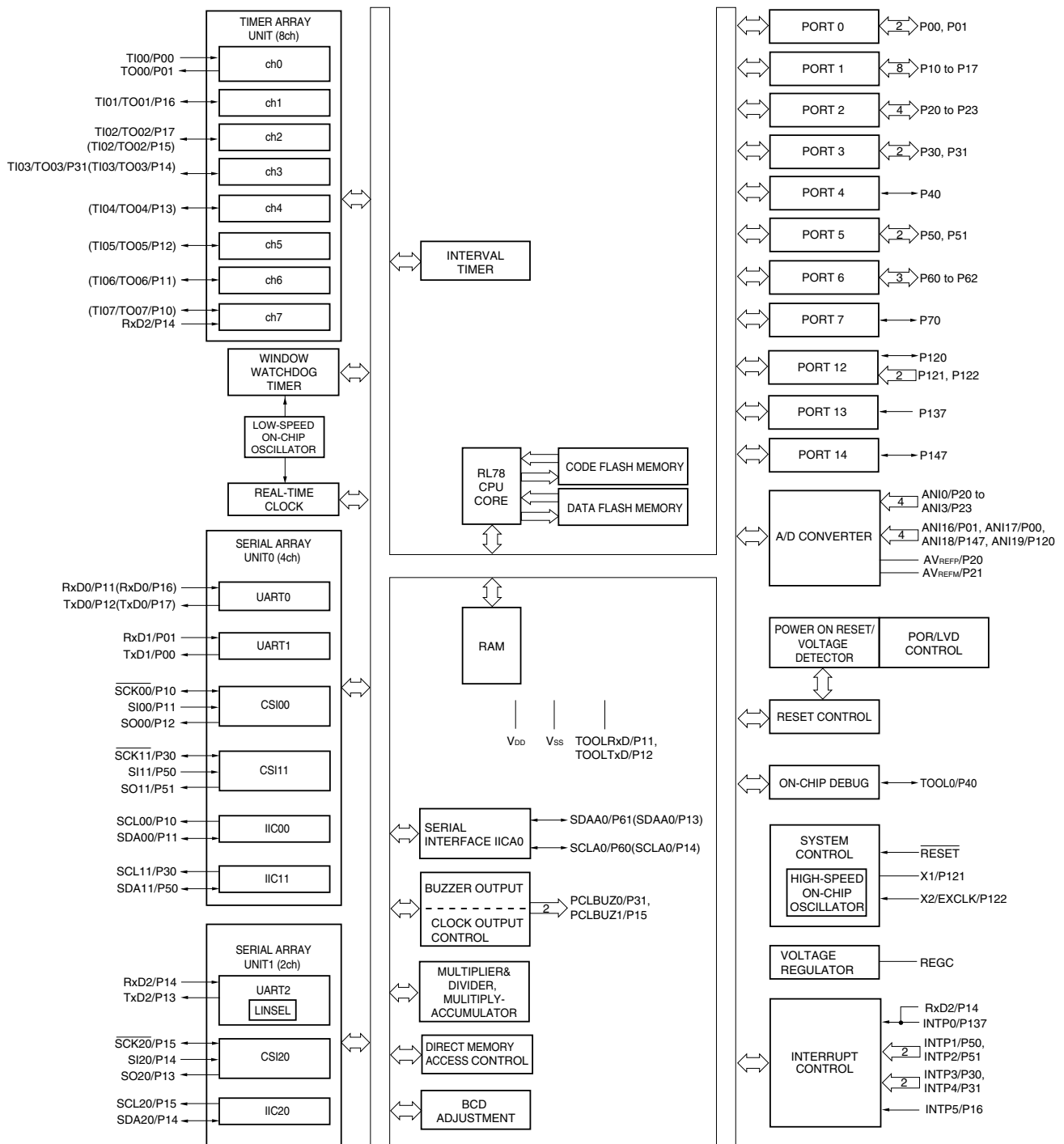


<R> 1.5.4 30-pin products



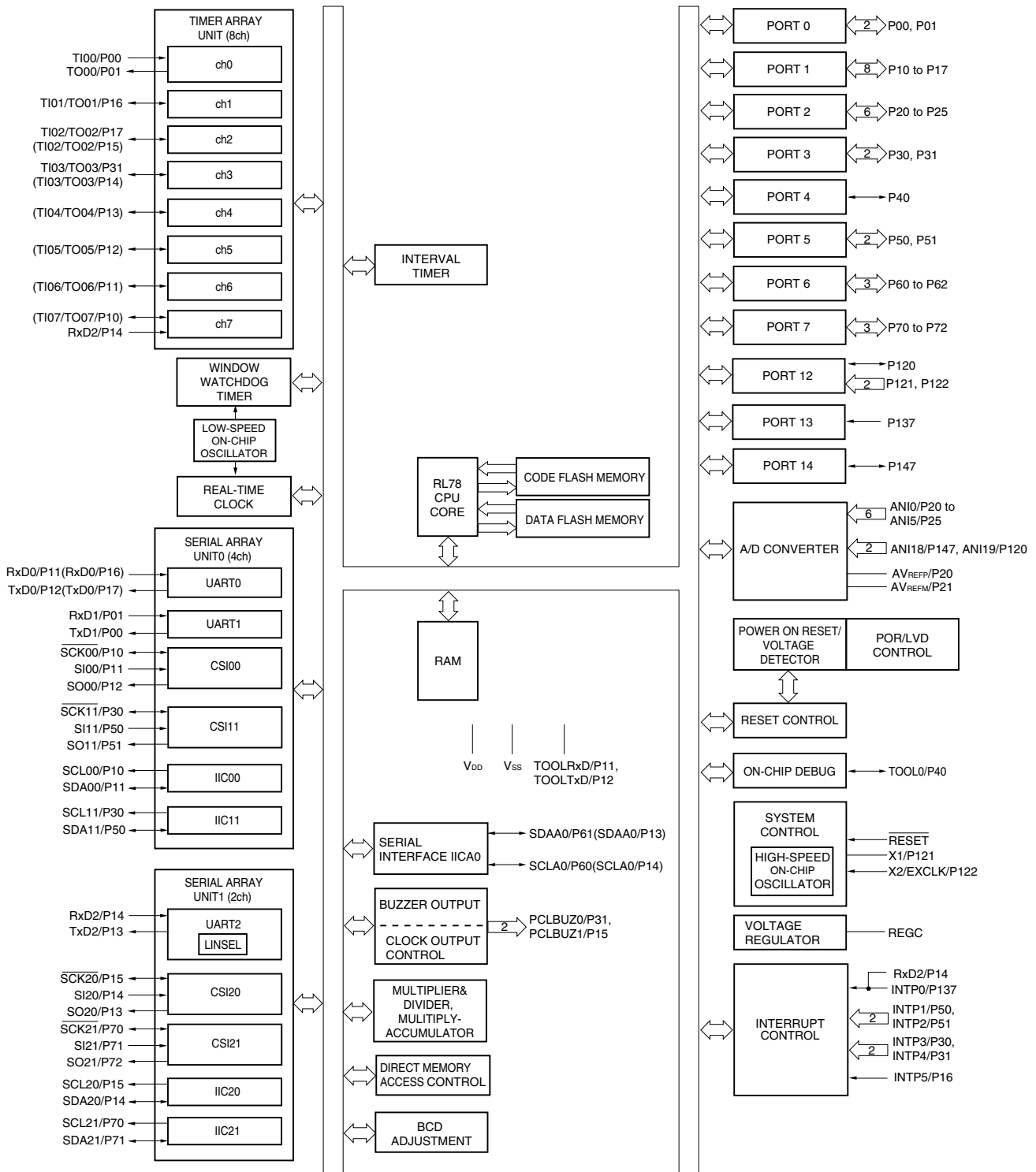
**Remark** Functions in parentheses in the above figure can be assigned via settings in the peripheral I/O redirection register (PIOR).

<R> 1.5.5 32-pin products



**Remark** Functions in parentheses in the above figure can be assigned via settings in the peripheral I/O redirection register (PIOR).

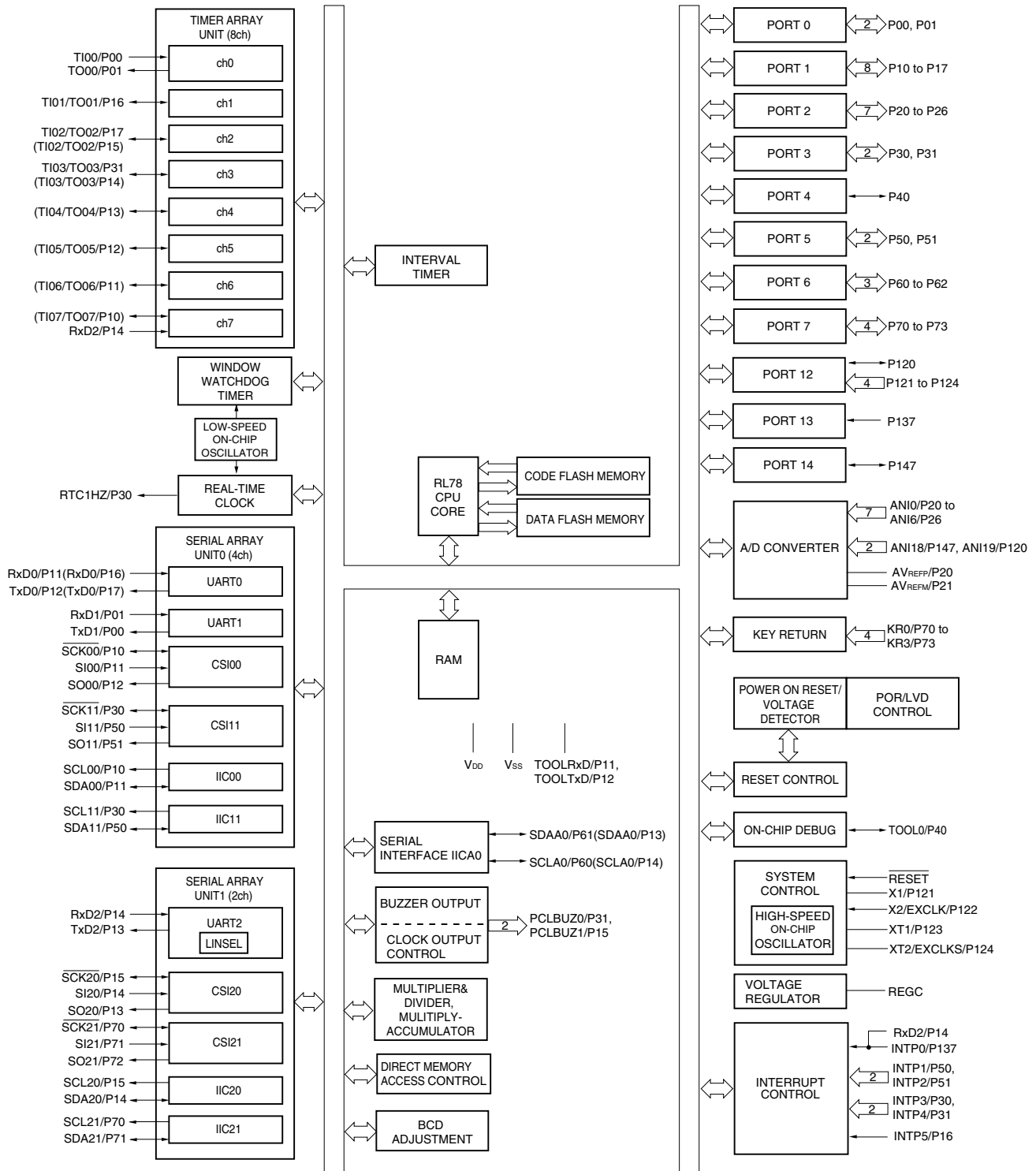
<R> 1.5.6 36-pin products



**Remark** Functions in parentheses in the above figure can be assigned via settings in the peripheral I/O redirection register (PIOR).

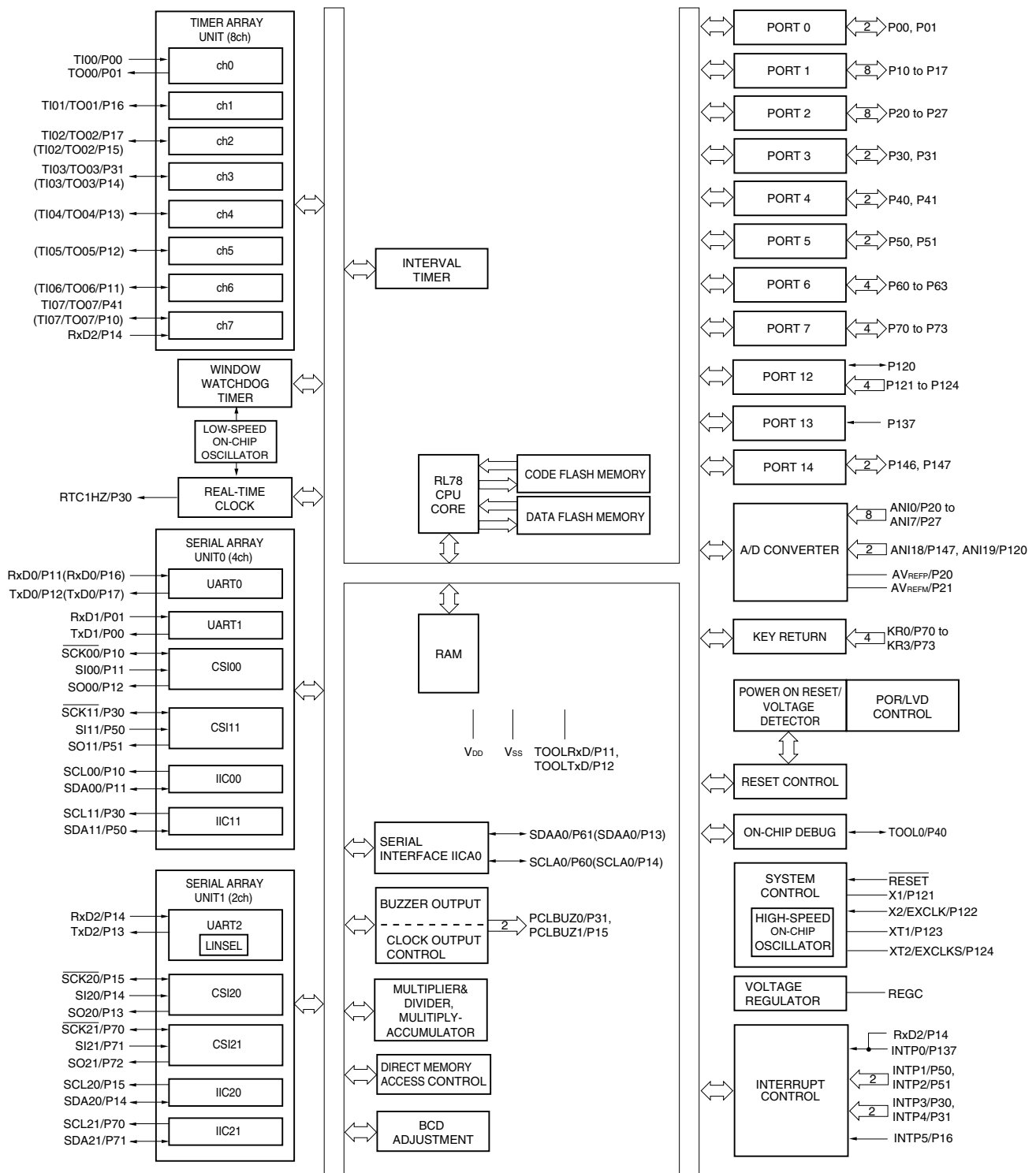


<R> 1.5.7 40-pin products



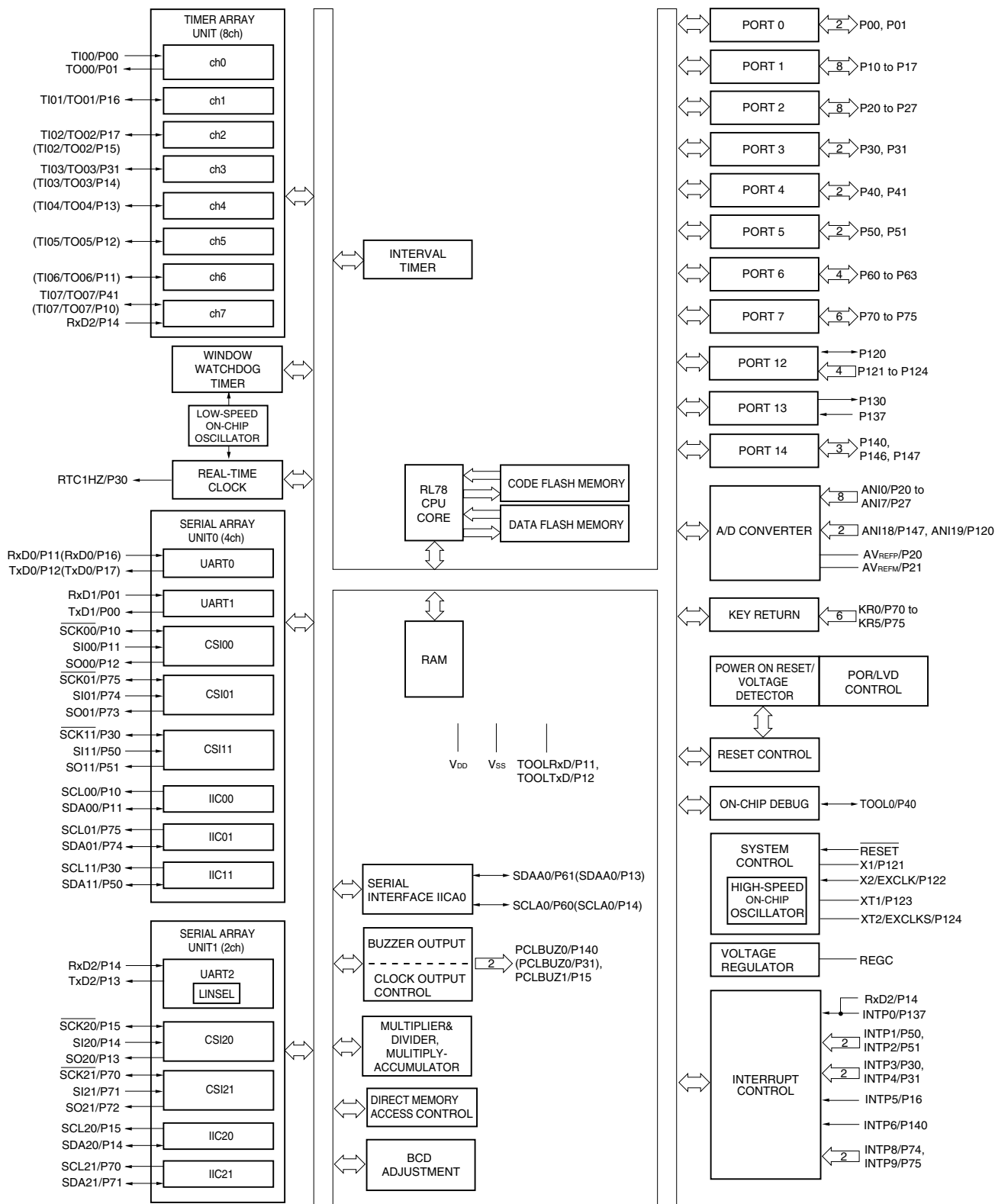
**Remark** Functions in parentheses in the above figure can be assigned via settings in the peripheral I/O redirection register (PIOR).

<R> 1.5.8 44-pin products



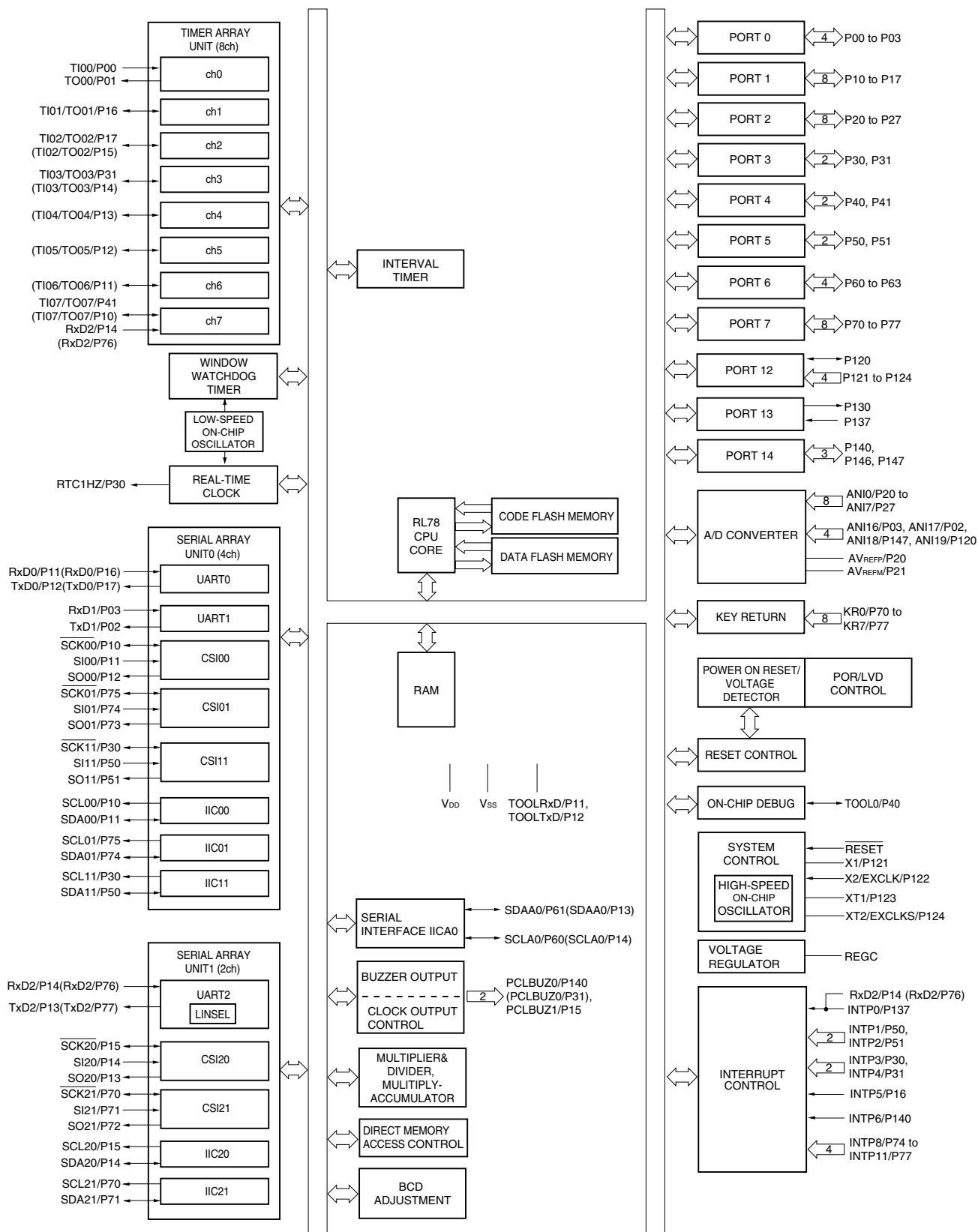
**Remark** Functions in parentheses in the above figure can be assigned via settings in the peripheral I/O redirection register (PIOR).

<R> 1.5.9 48-pin products



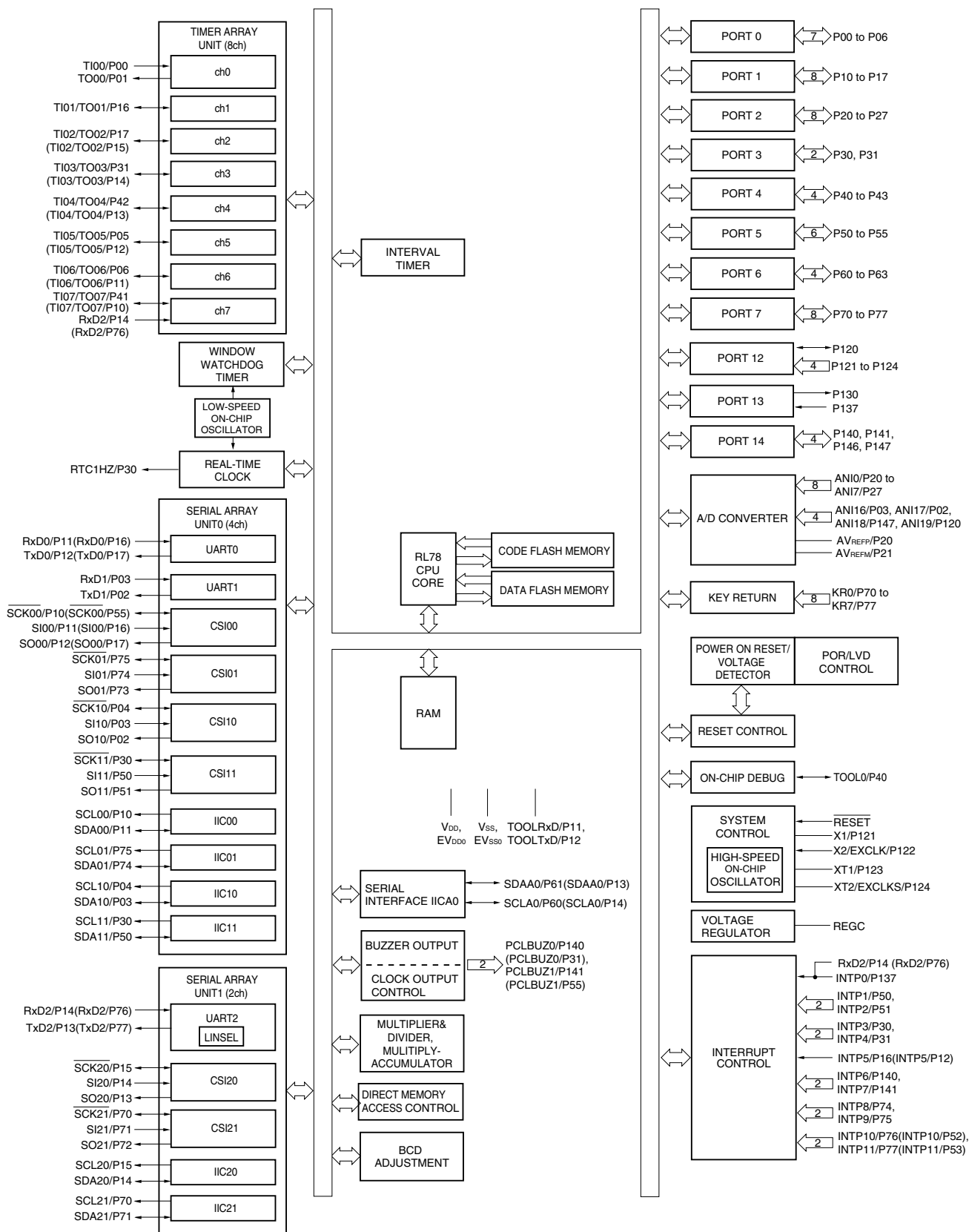
**Remark** Functions in parentheses in the above figure can be assigned via settings in the peripheral I/O redirection register (PIOR).

<R> 1.5.10 52-pin products



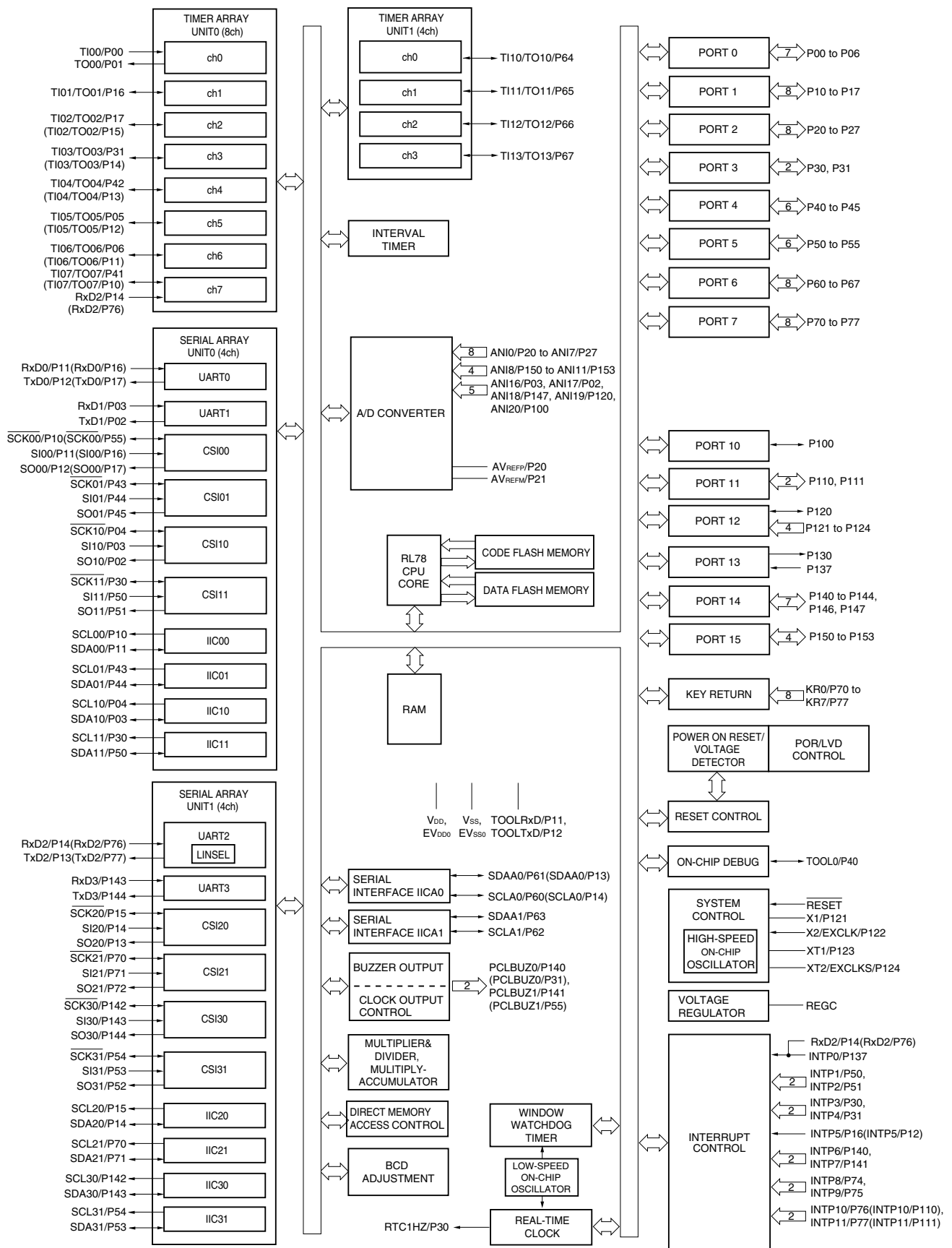
**Remark** Functions in parentheses in the above figure can be assigned via settings in the peripheral I/O redirection register (PIOR).

<R> 1.5.11 64-pin products



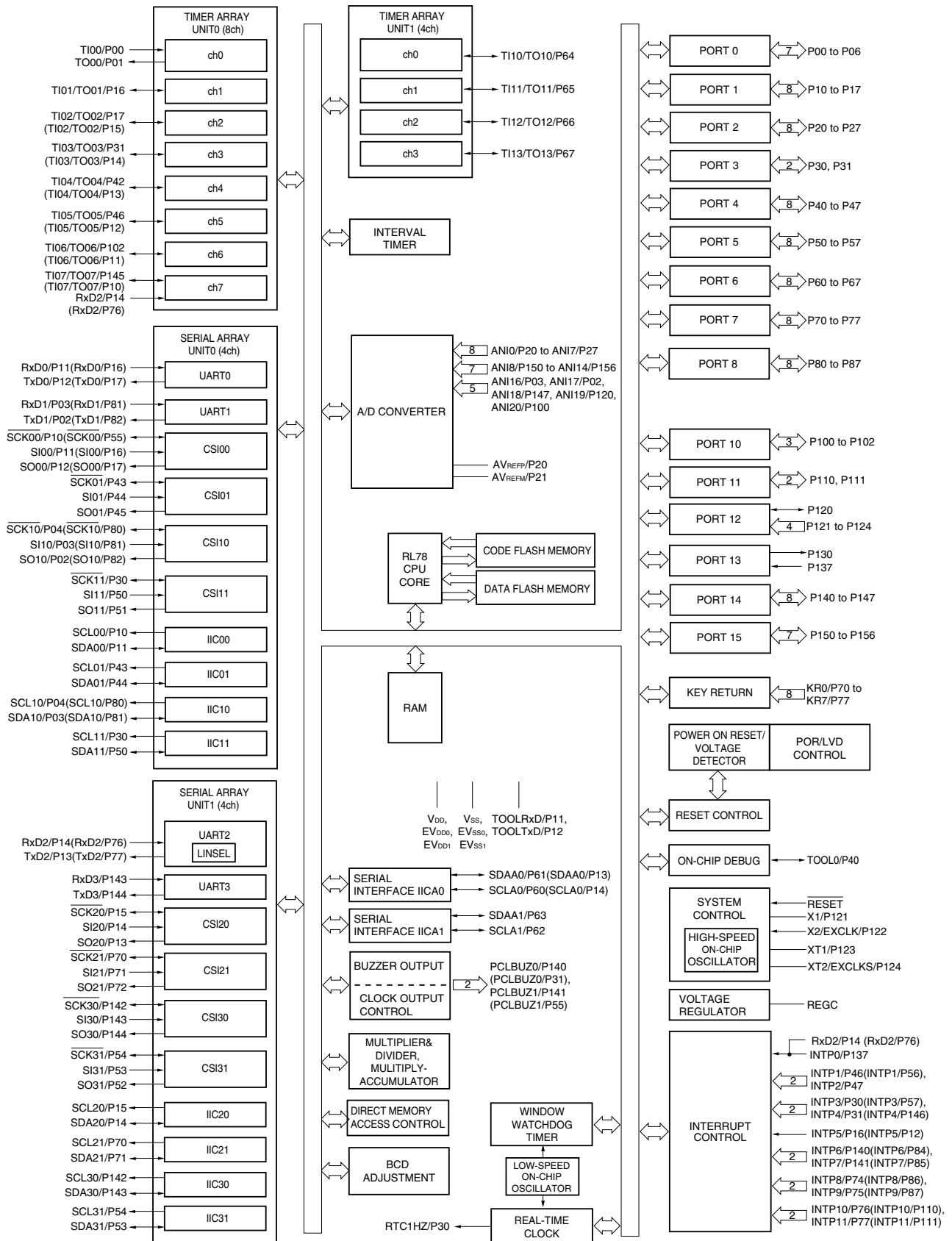
**Remark** Functions in parentheses in the above figure can be assigned via settings in the peripheral I/O redirection register (PIOR).

<R> 1.5.12 80-pin products



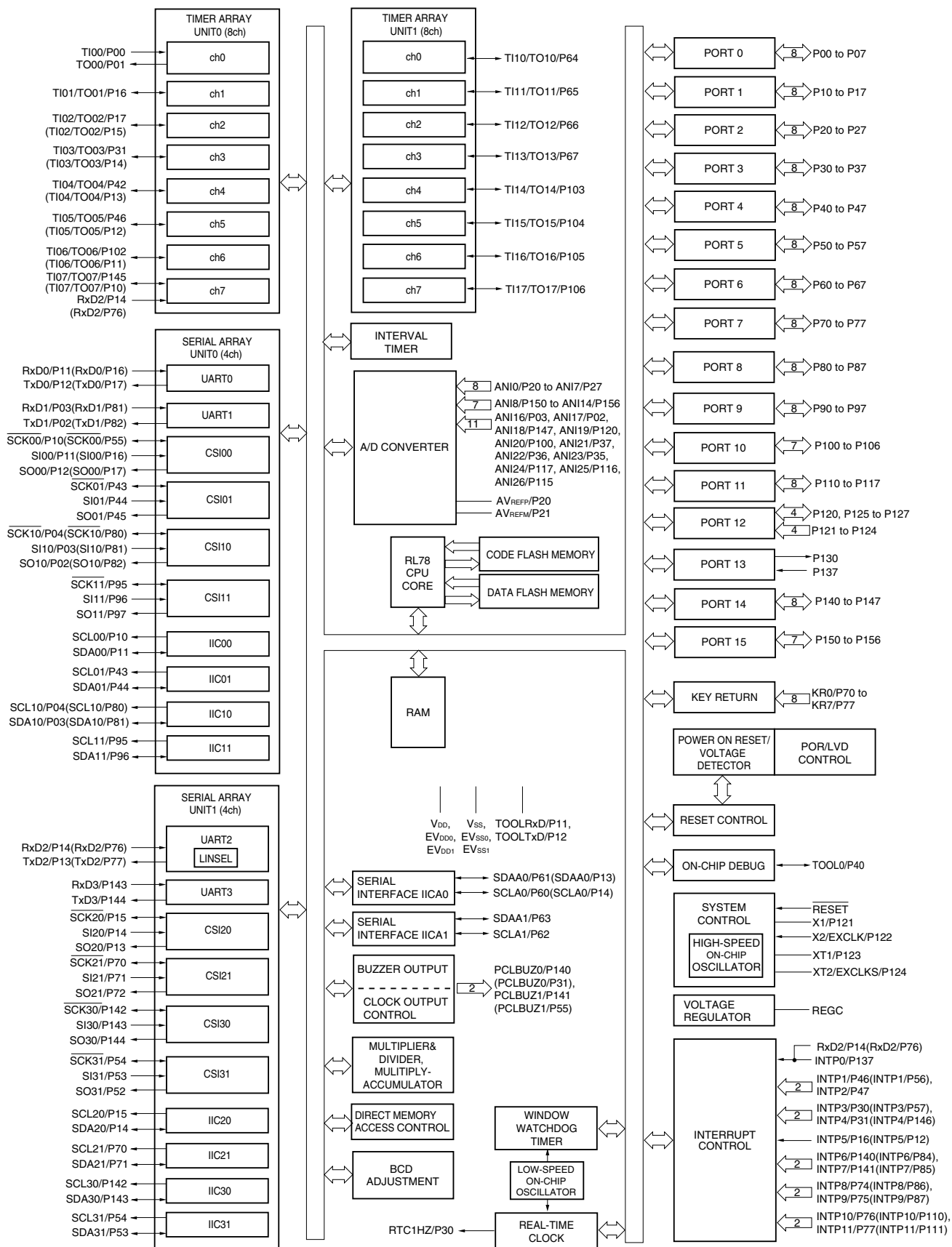
**Remark** Functions in parentheses in the above figure can be assigned via settings in the peripheral I/O redirection register (PIOR).

<R> 1.5.13 100-pin products



**Remark** Functions in parentheses in the above figure can be assigned via settings in the peripheral I/O redirection register (PIOR).

<R> 1.5.14 128-pin products



**Remark** Functions in parentheses in the above figure can be assigned via settings in the peripheral I/O redirection register (PIOR).



## 1.6 Outline of Functions

[20-pin, 24-pin, 25-pin, 30-pin, 32-pin, 36-pin products]

**Caution** This outline describes the functions at the time when Peripheral I/O redirection register (PIOR) is set to 00H.

(1/2)

Item	20-pin		24-pin		25-pin		30-pin		32-pin		36-pin		
	R5F1006X	R5F1016X	R5F1007X	R5F1017X	R5F1008X	R5F1018X	R5F100AX	R5F101AX	R5F100BX	R5F101BX	R5F100CX	R5F101CX	
Code flash memory (KB)	16 to 64		16 to 64		16 to 64		16 to 128		16 to 128		16 to 128		
Data flash memory (KB)	4	–	4	–	4	–	4 to 8	–	4 to 8	–	4 to 8	–	
RAM (KB)	2 to 4 <sup>Note1</sup>		2 to 4 <sup>Note1</sup>		2 to 4 <sup>Note1</sup>		2 to 12 <sup>Note1</sup>		2 to 12 <sup>Note1</sup>		2 to 12 <sup>Note1</sup>		
Memory space	1 MB												
Main system clock	High-speed system clock	X1 (crystal/ceramic) oscillation, external main system clock input (EXCLK) 1 to 20 MHz: V <sub>DD</sub> = 2.7 to 5.5 V, 1 to 8 MHz: V <sub>DD</sub> = 1.8 to 2.7 V, 1 to 4 MHz: V <sub>DD</sub> = 1.6 to 1.8 V											
	High-speed on-chip oscillator	High-speed operation: 1 to 32 MHz (V <sub>DD</sub> = 2.7 to 5.5 V), High-speed operation: 1 to 16 MHz (V <sub>DD</sub> = 2.4 to 5.5 V), Low-speed operation: 1 to 8 MHz (V <sub>DD</sub> = 1.8 to 5.5 V), Low-voltage operation: 1 to 4 MHz (V <sub>DD</sub> = 1.6 to 5.5 V)											
Subsystem clock	–												
Low-speed on-chip oscillator	15 kHz (TYP.): V <sub>DD</sub> = 1.6 to 5.5 V												
General-purpose register	8 bits × 32 registers (8 bits × 8 registers × 4 banks)												
Minimum instruction execution time	0.03125 μs (High-speed on-chip oscillator: f <sub>IH</sub> = 32 MHz operation)												
	0.05 μs (High-speed system clock: f <sub>MX</sub> = 20 MHz operation)												
Instruction set	<ul style="list-style-type: none"> <li>• Data transfer (8/16 bits)</li> <li>• Adder and subtractor/logical operation (8/16 bits)</li> <li>• Multiplication (8 bits × 8 bits)</li> <li>• Rotate, barrel shift, and bit manipulation (Set, reset, test, and Boolean operation), etc.</li> </ul>												
I/O port	Total	16	20	21	26	28	32						
	CMOS I/O	13	15	15	21	22	26						
	CMOS input	3	3	3	3	3	3						
	CMOS output	–	–	1	–	–	–						
	N-ch open-drain I/O (6 V tolerance)	–	2	2	2	3	3						
Timer	16-bit timer	8 channels											
	Watchdog timer	1 channel											
	Real-time clock (RTC)	1 channel											
	Interval timer (IT)	1 channel											
	Timer output	3 channels (PWM outputs: 2 <sup>Note2</sup> )	4 channels (PWM outputs: 3 <sup>Note2</sup> )										
	RTC output	–											

**Notes** 1. In the case of the 4 KB, this is about 3 KB when the self-programming function and data flash function are used. (For details, see **CHAPTER 3**)

2. The number of outputs varies, depending on the setting.

(2/2)

Item	20-pin		24-pin		25-pin		30-pin		32-pin		36-pin		
	R5F1006x	R5F1016x	R5F1007x	R5F1017x	R5F1008x	R5F1018x	R5F100Ax	R5F101Ax	R5F100Bx	R5F101Bx	R5F100Cx	R5F101Cx	
Clock output/buzzer output	–		1		1		2		2		2		
	<ul style="list-style-type: none"> <li>2.44 kHz, 4.88 kHz, 9.76 kHz, 1.25 MHz, 2.5 MHz, 5 MHz, 10 MHz (Main system clock: <math>f_{MAIN} = 20</math> MHz operation)</li> <li>256 Hz, 512 Hz, 1.024 kHz, 2.048 kHz, 4.096 kHz, 8.192 kHz, 16.384 kHz, 32.768 kHz (Subsystem clock: <math>f_{SUB} = 32.768</math> kHz operation)</li> </ul>												
8/10-bit resolution A/D converter	6 channels		6 channels		6 channels		8 channels		8 channels		8 channels		
Serial interface	<p>[20-pin, 24-pin, 25-pin products]</p> <ul style="list-style-type: none"> <li>CSI: 1 channel/UART: 1 channel/simplified I<sup>2</sup>C: 1 channel</li> <li>CSI: 1 channel/UART: 1 channel/simplified I<sup>2</sup>C: 1 channel</li> </ul> <p>[30-pin, 32-pin products]</p> <ul style="list-style-type: none"> <li>CSI: 1 channel/UART: 1 channel/simplified I<sup>2</sup>C: 1 channel</li> <li>CSI: 1 channel/UART: 1 channel/simplified I<sup>2</sup>C: 1 channel</li> <li>CSI: 1 channel/UART (UART supporting LIN-bus): 1 channel/simplified I<sup>2</sup>C: 1 channel</li> </ul> <p>[36-pin products]</p> <ul style="list-style-type: none"> <li>CSI: 1 channel/UART: 1 channel/simplified I<sup>2</sup>C: 1 channel</li> <li>CSI: 1 channel/UART: 1 channel/simplified I<sup>2</sup>C: 1 channel</li> <li>CSI: 2 channel/UART (UART supporting LIN-bus): 1 channel/simplified I<sup>2</sup>C: 2 channel</li> </ul>												
I <sup>2</sup> C bus	–		1 channel		1 channel		1 channel		1 channel		1 channel		
Multiplier and divider/multiply-accumulator	<ul style="list-style-type: none"> <li>16 bits × 16 bits = 32 bits (Unsigned or signed)</li> <li>32 bits ÷ 32 bits = 32 bits (Unsigned)</li> <li>16 bits × 16 bits + 32 bits = 32 bits (Unsigned or signed)</li> </ul>												
DMA controller	2 channels												
Vectored interrupt sources	Internal	23		24		24		27		27		27	
	External	3		5		5		6		6		6	
Key interrupt	–												
Reset	<ul style="list-style-type: none"> <li>Reset by <math>\overline{RESET}</math> pin</li> <li>Internal reset by watchdog timer</li> <li>Internal reset by power-on-reset</li> <li>Internal reset by voltage detector</li> <li>Internal reset by illegal instruction execution <sup>Note</sup></li> <li>Internal reset by RAM parity error</li> <li>Internal reset by illegal-memory access</li> </ul>												
Power-on-reset circuit	<ul style="list-style-type: none"> <li>Power-on-reset: 1.51 ±0.03 V</li> <li>Power-down-reset: 1.50 ±0.03 V</li> </ul>												
Voltage detector	1.63 V to 4.06 V (14 stages)												
On-chip debug function	Provided												
Power supply voltage	$V_{DD} = 1.6$ to 5.5 V												
Operating ambient temperature	$T_A = -40$ to +85 °C												

**Note** The illegal instruction is generated when instruction code FFH is executed.

Reset by the illegal instruction execution not issued by emulation with the in-circuit emulator or on-chip debug emulator.

[40-pin, 44-pin, 48-pin, 52-pin, 64-pin products]

**Caution** This outline describes the functions at the time when Peripheral I/O redirection register (PIOR) is set to 00H.

(1/2)

Item	40-pin		44-pin		48-pin		52-pin		64-pin		
	R5F100EX	R5F101EX	R5F100FX	R5F101FX	R5F100GX	R5F101GX	R5F100JX	R5F101JX	R5F100LX	R5F101LX	
Code flash memory (KB)	16 to 192		16 to 512		16 to 512		32 to 512		32 to 512		
Data flash memory (KB)	4 to 8	–	4 to 8	–	4 to 8	–	4 to 8	–	4 to 8	–	
RAM (KB)	2 to 16 <sup>Note1</sup>		2 to 32 <sup>Note1</sup>		2 to 32 <sup>Note1</sup>		2 to 32 <sup>Note1</sup>		2 to 32 <sup>Note1</sup>		
Memory space	1 MB										
Main system clock	High-speed system clock	X1 (crystal/ceramic) oscillation, external main system clock input (EXCLK) 1 to 20 MHz: V <sub>DD</sub> = 2.7 to 5.5 V, 1 to 8 MHz: V <sub>DD</sub> = 1.8 to 2.7 V, 1 to 4 MHz: V <sub>DD</sub> = 1.6 to 1.8 V									
	High-speed on-chip oscillator	High-speed operation: 1 to 32 MHz (V <sub>DD</sub> = 2.7 to 5.5 V), High-speed operation: 1 to 16 MHz (V <sub>DD</sub> = 2.4 to 5.5 V), Low-speed operation: 1 to 8 MHz (V <sub>DD</sub> = 1.8 to 5.5 V), Low-voltage operation: 1 to 4 MHz (V <sub>DD</sub> = 1.6 to 5.5 V)									
Subsystem clock	XT1 (crystal) oscillation, external subsystem clock input (EXCLKS) 32.768 kHz (TYP.): V <sub>DD</sub> = 1.6 to 5.5 V										
Low-speed on-chip oscillator	15 kHz (TYP.): V <sub>DD</sub> = 1.6 to 5.5 V										
General-purpose register	8 bits × 32 registers (8 bits × 8 registers × 4 banks)										
Minimum instruction execution time	0.03125 μs (High-speed on-chip oscillator: f <sub>IH</sub> = 32 MHz operation)										
	0.05 μs (High-speed system clock: f <sub>MX</sub> = 20 MHz operation)										
	30.5 μs (Subsystem clock: f <sub>SUB</sub> = 32.768 kHz operation)										
Instruction set	<ul style="list-style-type: none"> <li>• Data transfer (8/16 bits)</li> <li>• Adder and subtractor/logical operation (8/16 bits)</li> <li>• Multiplication (8 bits × 8 bits)</li> <li>• Rotate, barrel shift, and bit manipulation (Set, reset, test, and Boolean operation), etc.</li> </ul>										
I/O port	Total	36	40	44	48	58					
	CMOS I/O	28	31	34	38	48					
	CMOS input	5	5	5	5	5					
	CMOS output	–	–	1	1	1					
	N-ch open-drain I/O (6 V tolerance)	3	4	4	4	4					
Timer	16-bit timer	8 channels									
	Watchdog timer	1 channel									
	Real-time clock (RTC)	1 channel									
	Interval timer (IT)	1 channel									
	Timer output	4 channels (PWM outputs: 3 <sup>Note2</sup> )	5 channels (PWM outputs: 4 <sup>Note2</sup> )							8 channels (PWM outputs: 7 <sup>Note2</sup> )	
	RTC output	1 • 1 Hz (subsystem clock: f <sub>SUB</sub> = 32.768 kHz or )									

- <R> **Notes**
1. In the case of the 4 KB, this is about 3 KB when the self-programming function and data flash function are used. (For details, see **CHAPTER 3**)  
In the case of the 20 KB, this is about 19 KB when the self-programming function and data flash function are used. (For details, see **CHAPTER 3**)  
In the case of the 32 KB, this is about 31 KB when the self-programming function and data flash function are used. (For details, see **CHAPTER 3**)
  2. The number of outputs varies, depending on the setting.

(2/2)

Item	40-pin		44-pin		48-pin		52-pin		64-pin		
	R5F100EX	R5F101EX	R5F100FX	R5F101FX	R5F100GX	R5F101GX	R5F100JX	R5F101JX	R5F100LX	R5F101LX	
Clock output/buzzer output	2		2		2		2		2		
	<ul style="list-style-type: none"> <li>2.44 kHz, 4.88 kHz, 9.76 kHz, 1.25 MHz, 2.5 MHz, 5 MHz, 10 MHz (Main system clock: <math>f_{\text{MAIN}} = 20</math> MHz operation)</li> <li>256 Hz, 512 Hz, 1.024 kHz, 2.048 kHz, 4.096 kHz, 8.192 kHz, 16.384 kHz, 32.768 kHz (Subsystem clock: <math>f_{\text{SUB}} = 32.768</math> kHz operation)</li> </ul>										
8/10-bit resolution A/D converter	9 channels		10 channels		10 channels		12 channels		12 channels		
Serial interface	<p>[40-pin, 44-pin products]</p> <ul style="list-style-type: none"> <li>CSI: 1 channel/UART: 1 channel/simplified I<sup>2</sup>C: 1 channel</li> <li>CSI: 1 channel/UART: 1 channel/simplified I<sup>2</sup>C: 1 channel</li> <li>CSI: 2 channels/UART (UART supporting LIN-bus): 1 channel/simplified I<sup>2</sup>C: 2 channels</li> </ul> <p>[48-pin, 52-pin products]</p> <ul style="list-style-type: none"> <li>CSI: 2 channels/UART: 1 channel/simplified I<sup>2</sup>C: 2 channels</li> <li>CSI: 1 channel/UART: 1 channel/simplified I<sup>2</sup>C: 1 channel</li> <li>CSI: 2 channels/UART (UART supporting LIN-bus): 1 channel/simplified I<sup>2</sup>C: 2 channels</li> </ul> <p>[64-pin products]</p> <ul style="list-style-type: none"> <li>CSI: 2 channels/UART: 1 channel/simplified I<sup>2</sup>C: 2 channels</li> <li>CSI: 2 channels/UART: 1 channel/simplified I<sup>2</sup>C: 2 channels</li> <li>CSI: 2 channels/UART (UART supporting LIN-bus): 1 channel/simplified I<sup>2</sup>C: 2 channels</li> </ul>										
	I <sup>2</sup> C bus	1 channel		1 channel		1 channel		1 channel		1 channel	
Multiplier and divider/multiply-accumulator	<ul style="list-style-type: none"> <li>16 bits × 16 bits = 32 bits (Unsigned or signed)</li> <li>32 bits ÷ 32 bits = 32 bits (Unsigned)</li> <li>16 bits × 16 bits + 32 bits = 32 bits (Unsigned or signed)</li> </ul>										
DMA controller	2 channels										
Vectored interrupt sources	Internal	27		27		27		27		27	
	External	7		7		10		12		13	
Key interrupt	4		4		6		8		8		
Reset	<ul style="list-style-type: none"> <li>Reset by RESET<math>\bar</math> pin</li> <li>Internal reset by watchdog timer</li> <li>Internal reset by power-on-reset</li> <li>Internal reset by voltage detector</li> <li>Internal reset by illegal instruction execution <sup>Note</sup></li> <li>Internal reset by RAM parity error</li> <li>Internal reset by illegal-memory access</li> </ul>										
Power-on-reset circuit	<ul style="list-style-type: none"> <li>Power-on-reset: 1.51 ± 0.03 V</li> <li>Power-down-reset: 1.50 ± 0.03 V</li> </ul>										
Voltage detector	1.63 V to 4.06 V (14 stages)										
On-chip debug function	Provided										
Power supply voltage	$V_{\text{DD}} = 1.6$ to 5.5 V										
Operating ambient temperature	$T_{\text{A}} = -40$ to +85 °C										

**Note** The illegal instruction is generated when instruction code FFH is executed.

Reset by the illegal instruction execution not issued by emulation with the in-circuit emulator or on-chip debug emulator.

[80-pin, 100-pin, 128-pin products]

(1/2)

Item		80-pin		100-pin		128-pin	
		R5F100Mx	R5F101Mx	R5F100Px	R5F101Px	R5F100Sx	R5F101Sx
Code flash memory (KB)		96 to 512		96 to 512		192 to 512	
Data flash memory (KB)		8	–	8	–	8	–
RAM (KB)		8 to 32 <sup>Note1</sup>		8 to 32 <sup>Note1</sup>		16 to 32 <sup>Note1</sup>	
Memory space		1 MB					
Main system clock	High-speed system clock	X1 (crystal/ceramic) oscillation, external main system clock input (EXCLK) 1 to 20 MHz: V <sub>DD</sub> = 2.7 to 5.5 V, 1 to 8 MHz: V <sub>DD</sub> = 1.8 to 2.7 V, 1 to 4 MHz: V <sub>DD</sub> = 1.6 to 1.8 V					
	High-speed on-chip oscillator	High-speed operation: 1 to 32 MHz (V <sub>DD</sub> = 2.7 to 5.5 V), High-speed operation: 1 to 16 MHz (V <sub>DD</sub> = 2.4 to 5.5 V), Low-speed operation: 1 to 8 MHz (V <sub>DD</sub> = 1.8 to 5.5 V), Low-voltage operation: 1 to 4 MHz (V <sub>DD</sub> = 1.6 to 5.5 V)					
Subsystem clock		XT1 (crystal) oscillation, external subsystem clock input (EXCLKS) 32.768 kHz (TYP.): V <sub>DD</sub> = 1.6 to 5.5 V					
Low-speed on-chip oscillator		15 kHz (TYP.): V <sub>DD</sub> = 1.6 to 5.5 V					
General-purpose register		8 bits × 32 registers (8 bits × 8 registers × 4 banks)					
Minimum instruction execution time		0.03125 μs (High-speed on-chip oscillator: f <sub>H</sub> = 32 MHz operation)					
		0.05 μs (High-speed system clock: f <sub>MX</sub> = 20 MHz operation)					
		30.5 μs (Subsystem clock: f <sub>SUB</sub> = 32.768 kHz operation)					
Instruction set		<ul style="list-style-type: none"> <li>• Data transfer (8/16 bits)</li> <li>• Adder and subtractor/logical operation (8/16 bits)</li> <li>• Multiplication (8 bits × 8 bits)</li> <li>• Rotate, barrel shift, and bit manipulation (Set, reset, test, and Boolean operation), etc.</li> </ul>					
I/O port	Total	74		92		120	
	CMOS I/O	64		82		110	
	CMOS input	5		5		5	
	CMOS output	1		1		1	
	N-ch open-drain I/O (6 V tolerance)	4		4		4	
Timer	16-bit timer	12 channels		12 channels		16 channels	
	Watchdog timer	1 channel		1 channel		1 channel	
	Real-time clock (RTC)	1 channel		1 channel		1 channel	
	Interval timer (IT)	1 channel		1 channel		1 channel	
	Timer output	12 channels (PWM outputs: 10 <sup>Note2</sup> )		12 channels (PWM outputs: 10 <sup>Note2</sup> )		16 channels (PWM outputs: 14 <sup>Note2</sup> )	
	RTC output	1 • 1 Hz (subsystem clock: f <sub>SUB</sub> = 32.768 kHz or )					

- <R> **Notes 1.** In the case of the 20 KB, this is about 19 KB when the self-programming function and data flash function are used. (For details, see **CHAPTER 3**)  
In the case of the 32 KB, this is about 31 KB when the self-programming function and data flash function are used. (For details, see **CHAPTER 3**)
- 2.** The number of outputs varies, depending on the setting.

(2/2)

Item	80-pin		100-pin		128-pin	
	R5F100Mx	R5F101Mx	R5F100Px	R5F101Px	R5F100Sx	R5F101Sx
Clock output/buzzer output	2		2		2	
	<ul style="list-style-type: none"> <li>2.44 kHz, 4.88 kHz, 9.76 kHz, 1.25 MHz, 2.5 MHz, 5 MHz, 10 MHz (Main system clock: <math>f_{MAIN} = 20</math> MHz operation)</li> <li>256 Hz, 512 Hz, 1.024 kHz, 2.048 kHz, 4.096 kHz, 8.192 kHz, 16.384 kHz, 32.768 kHz (Subsystem clock: <math>f_{SUB} = 32.768</math> kHz operation)</li> </ul>					
8/10-bit resolution A/D converter	17 channels		20 channels		26 channels	
Serial interface	[80-pin, 100-pin, 128-pin products]					
	<ul style="list-style-type: none"> <li>CSI: 2 channels/UART: 1 channel/simplified I<sup>2</sup>C: 2 channels</li> <li>CSI: 2 channels/UART: 1 channel/simplified I<sup>2</sup>C: 2 channels</li> <li>CSI: 2 channels/UART (UART supporting LIN-bus): 1 channel/simplified I<sup>2</sup>C: 2 channels</li> <li>CSI: 2 channels/UART: 1 channel/simplified I<sup>2</sup>C: 2 channels</li> </ul>					
I <sup>2</sup> C bus	2 channel		2 channel		2 channel	
Multiplier and divider/multiply-accumulator	<ul style="list-style-type: none"> <li>16 bits × 16 bits = 32 bits (Unsigned or signed)</li> <li>32 bits ÷ 32 bits = 32 bits (Unsigned)</li> <li>16 bits × 16 bits + 32 bits = 32 bits (Unsigned or signed)</li> </ul>					
DMA controller	4 channels					
Vectored interrupt sources	Internal	37		37		41
	External	13		13		13
Key interrupt	8		8		8	
Reset	<ul style="list-style-type: none"> <li>Reset by <math>\overline{RESET}</math> pin</li> <li>Internal reset by watchdog timer</li> <li>Internal reset by power-on-reset</li> <li>Internal reset by voltage detector</li> <li>Internal reset by illegal instruction execution <sup>Note</sup></li> <li>Internal reset by RAM parity error</li> <li>Internal reset by illegal-memory access</li> </ul>					
Power-on-reset circuit	<ul style="list-style-type: none"> <li>Power-on-reset: 1.51 ±0.03 V</li> <li>Power-down-reset: 1.50 ±0.03 V</li> </ul>					
Voltage detector	1.63 V to 4.06 V (14 stages)					
On-chip debug function	Provided					
Power supply voltage	$V_{DD} = 1.6$ to 5.5 V					
Operating ambient temperature	$T_A = -40$ to +85 °C					

**Note** The illegal instruction is generated when instruction code FFH is executed.

Reset by the illegal instruction execution not issued by emulation with the in-circuit emulator or on-chip debug emulator.

## CHAPTER 2 PIN FUNCTIONS

## 2.1 Pin Function List

Pin I/O buffer power supplies depend on the product. The relationship between these power supplies and the pins is shown below.

Table 2-1. Pin I/O Buffer Power Supplies

## (1) 20-pin, 24-pin, 25-pin, 30-pin, 32-pin, 36-pin, 40-pin, 44-pin, 48-pin, 52-pin products

Power Supply	Corresponding Pins
V <sub>DD</sub>	All pins

## (2) 64-pin products

Power Supply	Corresponding Pins
EV <sub>DD0</sub>	Port pins other than P20 to P27, P121 to P124, and P137
V <sub>DD</sub>	<ul style="list-style-type: none"> <li>• P20 to P27, P121 to P124, and P137</li> <li>• Pins other than port pins</li> </ul>

## (3) 80-pin products

Power Supply	Corresponding Pins
EV <sub>DD0</sub>	Port pins other than P20 to P27, P121 to P124, P137, and P150 to P153
V <sub>DD</sub>	<ul style="list-style-type: none"> <li>• P20 to P27, P121 to P124, P137, and P150 to P153</li> <li>• Pins other than port pins</li> </ul>

## (4) 100-pin products

Power Supply	Corresponding Pins
EV <sub>DD0</sub> , EV <sub>DD1</sub>	Port pins other than P20 to P27, P121 to P124, P137, and P150 to P156
V <sub>DD</sub>	<ul style="list-style-type: none"> <li>• P20 to P27, P121 to P124, P137, and P150 to P156</li> <li>• Pins other than port pins</li> </ul>

## (5) 128-pin products

Power Supply	Corresponding Pins
EV <sub>DD0</sub> , EV <sub>DD1</sub>	Port pins other than P20 to P27, P121 to P124, P137, and P150 to P156
V <sub>DD</sub>	<ul style="list-style-type: none"> <li>• P20 to P27, P121 to P124, P137, and P150 to P156</li> <li>• Pins other than port pins</li> </ul>

## 2.1.1 20-pin products

Function Name	I/O	Function	After Reset	Alternate Function
P00	I/O	Port 0. 2-bit I/O port. Input of P01 can be set to TTL input buffer. Output of P00 can be set to N-ch open-drain output ( $V_{DD}$ tolerance). P00 and P01 can be set to analog input. Input/output can be specified in 1-bit units. Use of an on-chip pull-up resistor can be specified by a software setting.	Analog input port	ANI17/TI00/TxD1
P01				ANI16/TO00/RxD1
P10	I/O	Port 1. 5-bit I/O port. Input of P10, P11, P16, and P17 can be set to TTL input buffer. Output of P10 to P12, and P17 can be set to N-ch open-drain output ( $V_{DD}$ tolerance). Input/output can be specified in 1-bit units. Use of an on-chip pull-up resistor can be specified by a software setting.	Input port	SCK00/SCL00
P11				SI00/RxD0/ TOOLRxD/SDA00
P12				SO00/TxD0/ TOOLTxD
P16				TI01/TO01/INTP5/ SO11
P17				TI02/TO02/SI11/ SDA11
P20	I/O	Port 2. 3-bit I/O port. Input/output can be specified in 1-bit units.	Analog input port	ANI0/AV <sub>REFP</sub>
P21				ANI1/AV <sub>REFM</sub>
P22				ANI2
P30	I/O	Port 3. 1-bit I/O port. Input/output can be specified. Use of an on-chip pull-up resistor can be specified by a software setting.	Input port	INTP3/ SCK11/SCL11
P40	I/O	Port 4. 1-bit I/O port. Input/output can be specified. Use of an on-chip pull-up resistor can be specified by a software setting.	Input port	TOOL0
P121	Input	Port 12. 2-bit input port.	Input port	X1
P122				X2/EXCLK
P137	Input	Port 13. 1-bit input port.	Input port	INTP0
P147	I/O	Port 14. 1-bit I/O port. P147 can be set to analog input. Input/output can be specified. Use of an on-chip pull-up resistor can be specified by a software setting.	Analog input port	ANI18



## 2.1.2 24-pin products

Function Name	I/O	Function	After Reset	Alternate Function
P00	I/O	Port 0. 2-bit I/O port. Input of P01 can be set to TTL input buffer. Output of P00 can be set to N-ch open-drain output ( $V_{DD}$ tolerance). P00 and P01 can be set to analog input. Input/output can be specified in 1-bit units. Use of an on-chip pull-up resistor can be specified by a software setting.	Analog input port	ANI17/TI00/TxD1
P01				ANI16/TO00/RxD1
P10	I/O	Port 1. 5-bit I/O port. Input of P10, P11, P16, and P17 can be set to TTL input buffer. Output of P10 to P12, and P17 can be set to N-ch open-drain output ( $V_{DD}$ tolerance). Input/output can be specified in 1-bit units. Use of an on-chip pull-up resistor can be specified by a software setting.	Input port	SCK00/SCL00
P11				SI00/RxD0/ TOOLRxD/SDA00
P12				SO00/TxD0/ TOOLTxD
P16				TI01/TO01/INTP5
P17				TI02/TO02/SO11
P20	I/O	Port 2. 3-bit I/O port. Input/output can be specified in 1-bit units.	Analog input port	ANI0/AV <sub>REFP</sub>
P21				ANI1/AV <sub>REFM</sub>
P22				ANI2
P30	I/O	Port 3. 2-bit I/O port. Input/output can be specified in 1-bit units. Use of an on-chip pull-up resistor can be specified by a software setting.	Input port	INTP3/ SCK11/SCL11
P31				TI03/TO03/INTP4/PCL BUZO
P40	I/O	Port 4. 1-bit I/O port. Input/output can be specified. Use of an on-chip pull-up resistor can be specified by a software setting.	Input port	TOOL0
P50	I/O	Port 5. 1-bit I/O port. Output of P50 can be set to N-ch open-drain output ( $V_{DD}$ tolerance). Input/output can be specified. Use of an on-chip pull-up resistor can be specified by a software setting.	Input port	INTP1/SI11/SDA11
P60	I/O	Port 6. 2-bit I/O port. Output of P60 and P61 can be set to N-ch open-drain output (6 V tolerance). Input/output can be specified in 1-bit units.	Input port	SCLA0
P61				SDAA0
P121	Input	Port 12. 2-bit input port.	Input port	X1
P122				X2/EXCLK
P137	Input	Port 13. 1-bit input port.	Input port	INTP0
P147	I/O	Port 14. 1-bit I/O port. P147 can be set to analog input. Input/output can be specified. Use of an on-chip pull-up resistor can be specified by a software setting.	Analog input port	ANI18

## 2.1.3 25-pin products

Function Name	I/O	Function	After Reset	Alternate Function
P00	I/O	Port 0. 2-bit I/O port. Input of P01 can be set to TTL input buffer. Output of P00 can be set to N-ch open-drain output ( $V_{DD}$ tolerance). P00 and P01 can be set to analog input. Input/output can be specified in 1-bit units. Use of an on-chip pull-up resistor can be specified by a software setting.	Analog input port	ANI17/TI00/TxD1
P01				ANI16/TO00/RxD1
P10	I/O	Port 1. 5-bit I/O port. Input of P10, P11, P16, and P17 can be set to TTL input buffer. Output of P10 to P12, and P17 can be set to N-ch open-drain output ( $V_{DD}$ tolerance). Input/output can be specified in 1-bit units. Use of an on-chip pull-up resistor can be specified by a software setting.	Input port	SCK00/SCL00
P11				SI00/RxD0/ TOOLRxD/SDA00
P12				SO00/TxD0/ TOOLTxD
P16				TI01/TO01/INTP5
P17				TI02/TO02/SO11
P20	I/O	Port 2. 3-bit I/O port. Input/output can be specified in 1-bit units.	Analog input port	ANI0/AV <sub>REFP</sub>
P21				ANI1/AV <sub>REFM</sub>
P22				ANI2
P30	I/O	Port 3. 2-bit I/O port. Input/output can be specified in 1-bit units. Use of an on-chip pull-up resistor can be specified by a software setting.	Input port	INTP3/ SCK11/SCL11
P31				TI03/TO03/INTP4/ PCLBUZ0
P40	I/O	Port 4. 1-bit I/O port. Input/output can be specified. Use of an on-chip pull-up resistor can be specified by a software setting.	Input port	TOOL0
P50	I/O	Port 5. 1-bit I/O port. Output of P50 can be set to N-ch open-drain output ( $V_{DD}$ tolerance). Input/output can be specified. Use of an on-chip pull-up resistor can be specified by a software setting.	Input port	INTP1/SI11/SDA11
P60	I/O	Port 6. 2-bit I/O port. Output of P60 and P61 can be set to N-ch open-drain output (6 V tolerance). Input/output can be specified in 1-bit units.	Input port	SCLA0
P61				SDAA0
P121	Input	Port 12. 2-bit input port.	Input port	X1
P122				X2/EXCLK
P130	Output	Port 13. 1-bit output port and 1-bit input port.	Output port	–
P137	Input		Input port	INTP0
P147	I/O	Port 14. 1-bit I/O port. P147 can be set to analog input. Input/output can be specified. Use of an on-chip pull-up resistor can be specified by a software setting.	Analog input port	ANI18

## &lt;R&gt; 2.1.4 30-pin products

(1/2)

Function Name	I/O	Function	After Reset	Alternate Function
P00	I/O	Port 0. 2-bit I/O port. Input of P01 can be set to TTL input buffer. Output of P00 can be set to N-ch open-drain output ( $V_{DD}$ tolerance). P00 and P01 can be set to analog input. Input/output can be specified in 1-bit units. Use of an on-chip pull-up resistor can be specified by a software setting.	Analog input port	ANI17/TI00/TxD1
P01				ANI16/TO00/RxD1
P10	I/O	Port 1. 8-bit I/O port. Input of P10, P11, and P13 to P17 can be set to TTL input buffer. Output of P10 to P15, and P17 can be set to N-ch open-drain output ( $V_{DD}$ tolerance). Input/output can be specified in 1-bit units. Use of an on-chip pull-up resistor can be specified by a software setting.	Input port	SCK00/SCL00/(TI07)/(TO07)
P11				SI00/RxD0/TOOLRxD/SDA00/(TI06)/(TO06)
P12				SO00/TxD0/TOOLTxD/(TI05)/(TO05)
P13				TxD2/SO20/(SDAA0)/(TI04)/(TO04)
P14				RxD2/SI20/SDA20/(SCLA0)/(TI03)/(TO03)
P15				PCLBUZ1/SCK20/SCL20/(TI02)/(TO02)
P16				TI01/TO01/INTP5/(RxD0)
P17				TI02/TO02/(TxD0)
P20	I/O	Port 2. 4-bit I/O port. Input/output can be specified in 1-bit units.	Analog input port	ANI0/AV <sub>REFP</sub>
P21				ANI1/AV <sub>REFM</sub>
P22				ANI2
P23				ANI3
P30	I/O	Port 3. 2-bit I/O port. Input/output can be specified in 1-bit units. Use of an on-chip pull-up resistor can be specified by a software setting.	Input port	INTP3/ SCK11/SCL11
P31				TI03/TO03/INTP4/ PCLBUZ0
P40	I/O	Port 4. 1-bit I/O port. Input/output can be specified. Use of an on-chip pull-up resistor can be specified by a software setting.	Input port	TOOL0

**Remark** Functions in parentheses in the above figure can be assigned via settings in the peripheral I/O redirection register (PIOR).

(2/2)

Function Name	I/O	Function	After Reset	Alternate Function
P50	I/O	Port 5. 2-bit I/O port. Output of P50 can be set to N-ch open-drain output ( $V_{DD}$ tolerance). Input/output can be specified in 1-bit units. Use of an on-chip pull-up resistor can be specified by a software setting.	Input port	INTP1/SI11/SDA11
P51				INTP2/SO11
P60	I/O	Port 6. 2-bit I/O port. Output of P60 and P61 can be set to N-ch open-drain output (6 V tolerance). Input/output can be specified in 1-bit units.	Input port	SCLA0
P61				SDAA0
P120	I/O	Port 12. 1-bit I/O port and 2-bit input port. P120 can be set to analog input. For only P120, input/output can be specified in 1-bit units. For only P120, use of an on-chip pull-up resistor can be specified by a software setting.	Analog input port	ANI19
P121	Input		Input port	X1
P122			X2/EXCLK	
P137	Input	Port 13. 1-bit input port.	Input port	INTP0
P147	I/O	Port 14. 1-bit I/O port. P147 can be set to analog input. Input/output can be specified. Use of an on-chip pull-up resistor can be specified by a software setting.	Analog input port	ANI18

## &lt;R&gt; 2.1.5 32-pin products

(1/2)

Function Name	I/O	Function	After Reset	Alternate Function
P00	I/O	Port 0. 2-bit I/O port. Input of P01 can be set to TTL input buffer. Output of P00 can be set to N-ch open-drain output ( $V_{DD}$ tolerance). P00 and P01 can be set to analog input. Input/output can be specified in 1-bit units. Use of an on-chip pull-up resistor can be specified by a software setting.	Analog input port	ANI17/TI00/TxD1
P01				ANI16/TO00/RxD1
P10	I/O	Port 1. 8-bit I/O port. Input of P10, P11, and P13 to P17 can be set to TTL input buffer. Output of P10 to P15, and P17 can be set to N-ch open-drain output ( $V_{DD}$ tolerance). Input/output can be specified in 1-bit units. Use of an on-chip pull-up resistor can be specified by a software setting.	Input port	SCK00/SCL00/(TI07)/(TO07)
P11				SI00/RxD0/TOOLRxD/SDA00/(TI06)/(TO06)
P12				SO00/TxD0/TOOLTxD/(TI05)/(TO05)
P13				TxD2/SO20/(SDAA0)/(TI04)/(TO04)
P14				RxD2/SI20/SDA20/(SCLA0)/(TI03)/(TO03)
P15				PCLBUZ1/SCK20/SCL20/(TI02)/(TO02)
P16				TI01/TO01/INTP5/(RxD0)
P17				TI02/TO02/(TxD0)
P20	I/O	Port 2. 4-bit I/O port. Input/output can be specified in 1-bit units.	Analog input port	ANI0/AV <sub>REFP</sub>
P21				ANI1/AV <sub>REFM</sub>
P22				ANI2
P23				ANI3
P30	I/O	Port 3. 2-bit I/O port. Input/output can be specified in 1-bit units. Use of an on-chip pull-up resistor can be specified by a software setting.	Input port	INTP3/ SCK11/SCL11
P31				TI03/TO03/INTP4/ PCLBUZ0
P40	I/O	Port 4. 1-bit I/O port. Input/output can be specified. Use of an on-chip pull-up resistor can be specified by a software setting.	Input port	TOOL0

**Remark** Functions in parentheses in the above figure can be assigned via settings in the peripheral I/O redirection register (PIOR).

(2/2)

Function Name	I/O	Function	After Reset	Alternate Function
P50	I/O	Port 5. 2-bit I/O port. Output of P50 can be set to N-ch open-drain output ( $V_{DD}$ tolerance). Input/output can be specified in 1-bit units. Use of an on-chip pull-up resistor can be specified by a software setting.	Input port	INTP1/SI11/SDA11
P51				INTP2/SO11
P60	I/O	Port 6. 3-bit I/O port. Output of P60 to P62 can be set to N-ch open-drain output (6 V tolerance). Input/output can be specified in 1-bit units.	Input port	SCLA0
P61				SDAA0
P62				–
P70	I/O	Port 7. 1-bit I/O port. Input/output can be specified. Use of an on-chip pull-up resistor can be specified by a software setting.	Input port	–
P120	I/O	Port 12. 1-bit I/O port and 2-bit input port. P120 can be set to analog input. For only P120, input/output can be specified in 1-bit units. For only P120, use of an on-chip pull-up resistor can be specified by a software setting.	Analog input port	ANI19
P121	Input		Input port	X1
P122				X2/EXCLK
P137	Input	Port 13. 1-bit input port.	Input port	INTP0
P147	I/O	Port 14. 1-bit I/O port. P147 can be set to analog input. Input/output can be specified. Use of an on-chip pull-up resistor can be specified by a software setting.	Analog input port	ANI18

## &lt;R&gt; 2.1.6 36-pin products

(1/2)

Function Name	I/O	Function	After Reset	Alternate Function
P00	I/O	Port 0. 2-bit I/O port. Input of P01 can be set to TTL input buffer. Output of P00 can be set to N-ch open-drain output ( $V_{DD}$ tolerance). Input/output can be specified in 1-bit units. Use of an on-chip pull-up resistor can be specified by a software setting.	Input port	TI00/TxD1
P01				TO00/RxD1
P10	I/O	Port 1. 8-bit I/O port. Input of P10, P11, and P13 to P17 can be set to TTL input buffer. Output of P10 to P15, and P17 can be set to N-ch open-drain output ( $V_{DD}$ tolerance). Input/output can be specified in 1-bit units. Use of an on-chip pull-up resistor can be specified by a software setting.	Input port	SCK00/SCL00 (TI07)/(TO07)
P11				SI00/RxD0/TOOLRxD/ SDA00/(TI06)/(TO06)
P12				SO00/TxD0/TOOLTxD (/TI05)/(TO05)
P13				TxD2/SO20/(SDAA0)/ (TI04)/(TO04)
P14				RxD2/SI20/SDA20/ (SCLA0)/(TI03)/ (TO03)
P15				PCLBUZ1/SCK20/ SCL20/(TI02)/(TO02)
P16				TI01/TO01/INTP5/ (RxD0)
P17				TI02/TO02/(TxD0)
P20	I/O	Port 2. 6-bit I/O port. Input/output can be specified in 1-bit units.	Analog input port	ANI0/AV <sub>REFP</sub>
P21				ANI1/AV <sub>REFM</sub>
P22				ANI2
P23				ANI3
P24				ANI4
P25				ANI5
P30	I/O	Port 3. 2-bit I/O port. Input/output can be specified in 1-bit units. Use of an on-chip pull-up resistor can be specified by a software setting.	Input port	INTP3/SCK11/SCL11
P31				TI03/TO03/INTP4/PCL BUZ0
P40	I/O	Port 4. 1-bit I/O port. Input/output can be specified. Use of an on-chip pull-up resistor can be specified by a software setting.	Input port	TOOL0

**Remark** Functions in parentheses in the above figure can be assigned via settings in the peripheral I/O redirection register (PIOR).

(2/2)

Function Name	I/O	Function	After Reset	Alternate Function
P50	I/O	Port 5. 2-bit I/O port. Output of P50 can be set to N-ch open-drain output ( $V_{DD}$ tolerance). Input/output can be specified in 1-bit units. Use of an on-chip pull-up resistor can be specified by a software setting.	Input port	INTP1/SI11/SDA11
P51				INTP2/SO11
P60	I/O	Port 6. 3-bit I/O port. Output of P60 to P62 can be set to N-ch open-drain output (6 V tolerance). Input/output can be specified in 1-bit units.	Input port	SCLA0
P61				SDAA0
P62				—
P70	I/O	Port 7. 3-bit I/O port. Output of P71 can be set to N-ch open-drain output ( $V_{DD}$ tolerance). Input/output can be specified in 1-bit units. Use of an on-chip pull-up resistor can be specified by a software setting.	Input port	$\overline{\text{SCK21/SCL21}}$
P71				SI21/SDA21
P72				SO21
P120	I/O	Port 12. 1-bit I/O port and 2-bit input port. P120 can be set to analog input. For only P120, input/output can be specified in 1-bit units. For only P120, use of an on-chip pull-up resistor can be specified by a software setting.	Analog input port	ANI19
P121	Input		Input port	X1
P122				X2/EXCLK
P137	Input	Port 13. 1-bit input port.	Input port	INTP0
P147	I/O	Port 14. 1-bit I/O port. P147 can be set to analog input. Input/output can be specified. Use of an on-chip pull-up resistor can be specified by a software setting.	Analog input port	ANI18



## &lt;R&gt; 2.1.7 40-pin products

(1/2)

Function Name	I/O	Function	After Reset	Alternate Function
P00	I/O	Port 0. 2-bit I/O port. Input of P01 can be set to TTL input buffer. Output of P00 can be set to N-ch open-drain output ( $V_{DD}$ tolerance). Input/output can be specified in 1-bit units. Use of an on-chip pull-up resistor can be specified by a software setting.	Input port	TI00/TxD1
P01				TO00/RxD1
P10	I/O	Port 1. 8-bit I/O port. Input of P10, P11, and P13 to P17 can be set to TTL input buffer. Output of P10 to P15, and P17 can be set to N-ch open-drain output ( $V_{DD}$ tolerance). Input/output can be specified in 1-bit units. Use of an on-chip pull-up resistor can be specified by a software setting.	Input port	SCK00/SCL00/(TI07)/(TO07)
P11				SI00/RxD0/TOOLRxD/SDA00/(TI06)/(TO06)
P12				SO00/TxD0/TOOLTxD/(TI05)/(TO05)
P13				TxD2/SO20/(SDAA0)/(TI04)/(TO04)
P14				RxD2/SI20/SDA20/(SCLA0)/(TI03)/(TO03)
P15				PCLBUZ1/SCK20/SCL20/(TI02)/(TO02)
P16				TI01/TO01/INTP5/(RxD0)
P17				TI02/TO02/(TxD0)
P20	I/O	Port 2. 7-bit I/O port. Input/output can be specified in 1-bit units.	Analog input port	ANI0/AV <sub>REFP</sub>
P21				ANI1/AV <sub>REFM</sub>
P22				ANI2
P23				ANI3
P24				ANI4
P25				ANI5
P26				ANI6
P30	I/O	Port 3. 2-bit I/O port. Input/output can be specified in 1-bit units. Use of an on-chip pull-up resistor can be specified by a software setting.	Input port	INTP3/RTC1HZ/ SCK11/SCL11
P31				TI03/TO03/INTP4/PCLBUZ0
P40	I/O	Port 4. 1-bit I/O port. Input/output can be specified in 1-bit units. Use of an on-chip pull-up resistor can be specified by a software setting.	Input port	TOOL0

**Remark** Functions in parentheses in the above figure can be assigned via settings in the peripheral I/O redirection register (PIOR).

(2/2)

Function Name	I/O	Function	After Reset	Alternate Function
P50	I/O	Port 5. 2-bit I/O port. Output of P50 can be set to N-ch open-drain output ( $V_{DD}$ tolerance). Input/output can be specified in 1-bit units. Use of an on-chip pull-up resistor can be specified by a software setting.	Input port	INTP1/SI11/SDA11
P51				INTP2/SO11
P60	I/O	Port 6. 3-bit I/O port. Output of P60 to P62 can be set to N-ch open-drain output (6 V tolerance). Input/output can be specified in 1-bit units.	Input port	SCLA0
P61				SDAA0
P62				—
P70	I/O	Port 7. 4-bit I/O port. Output of P71 can be set to N-ch open-drain output ( $V_{DD}$ tolerance). Input/output can be specified in 1-bit units. Use of an on-chip pull-up resistor can be specified by a software setting.	Input port	KR0/SCK21/SCL21
P71				KR1/SI21/SDA21
P72				KR2/SO21
P73				KR3
P120	I/O	Port 12. 1-bit I/O port and 4-bit input port. P120 can be set to analog input. For only P120, input/output can be specified in 1-bit units. For only P120, use of an on-chip pull-up resistor can be specified by a software setting.	Analog input port	ANI19
P121	Input		Input port	X1
P122				X2/EXCLK
P123				XT1
P124				XT2/EXCLKS
P137	Input	Port 13. 1-bit input port.	Input port	INTP0
P147	I/O	Port 14. 1-bit I/O port. P147 can be set to analog input. Input/output can be specified. Use of an on-chip pull-up resistor can be specified by a software setting.	Analog input port	ANI18

## &lt;R&gt; 2.1.8 44-pin products

(1/2)

Function Name	I/O	Function	After Reset	Alternate Function
P00	I/O	Port 0. 2-bit I/O port. Input of P01 can be set to TTL input buffer. Output of P00 can be set to N-ch open-drain output ( $V_{DD}$ tolerance). Input/output can be specified in 1-bit units. Use of an on-chip pull-up resistor can be specified by a software setting.	Input port	TI00/TxD1
P01				TO00/RxD1
P10	I/O	Port 1. 8-bit I/O port. Input of P10, P11, and P13 to P17 can be set to TTL input buffer. Output of P10 to P15, and P17 can be set to N-ch open-drain output ( $V_{DD}$ tolerance). Input/output can be specified in 1-bit units. Use of an on-chip pull-up resistor can be specified by a software setting.	Input port	SCK00/SCL00/(TI07)/ (TO07)
P11				SI00/RxD0/TOOLRxD/ SDA00/(TI06)/(TO06)
P12				SO00/TxD0/TOOLTxD (/TI05)/(TO05)
P13				TxD2/SO20/(SDAA0)/ (TI04)/(TO04)
P14				RxD2/SI20/SDA20/ (SCLA0)/(TI03)/ (TO03)
P15				PCLBUZ1/SCK20/ SCL20/(TI02)/(TO02)
P16				TI01/TO01/INTP5/ (RxD0)
P17				TI02/TO02/(TxD0)
P20	I/O	Port 2. 8-bit I/O port. Input/output can be specified in 1-bit units.	Analog input port	ANI0/AV <sub>REFP</sub>
P21				ANI1/AV <sub>REFM</sub>
P22				ANI2
P23				ANI3
P24				ANI4
P25				ANI5
P26				ANI6
P27				ANI7
P30	I/O	Port 3. 2-bit I/O port. Input/output can be specified in 1-bit units. Use of an on-chip pull-up resistor can be specified by a software setting.	Input port	INTP3/RTC1HZ/ SCK11/SCL11
P31				TI03/TO03/INTP4/PCL BUZ0
P40	I/O	Port 4. 2-bit I/O port. Input/output can be specified in 1-bit units. Use of an on-chip pull-up resistor can be specified by a software setting.	Input port	TOOL0
P41				TI07/TO07

**Remark** Functions in parentheses in the above figure can be assigned via settings in the peripheral I/O redirection register (PIOR).

(2/2)

Function Name	I/O	Function	After Reset	Alternate Function
P50	I/O	Port 5. 2-bit I/O port. Output of P50 can be set to N-ch open-drain output ( $V_{DD}$ tolerance). Input/output can be specified in 1-bit units. Use of an on-chip pull-up resistor can be specified by a software setting.	Input port	INTP1/SI11/SDA11
P51				INTP2/SO11
P60	I/O	Port 6. 4-bit I/O port. Output of P60 to P63 can be set to N-ch open-drain output (6 V tolerance). Input/output can be specified in 1-bit units.	Input port	SCLA0
P61				SDAA0
P62				–
P63				–
P70	I/O	Port 7. 4-bit I/O port. Output of P71 can be set to N-ch open-drain output ( $V_{DD}$ tolerance). Input/output can be specified in 1-bit units. Use of an on-chip pull-up resistor can be specified by a software setting.	Input port	KR0/SCK21/SCL21
P71				KR1/SI21/SDA21
P72				KR2/SO21
P73				KR3
P120	I/O	Port 12. 1-bit I/O port and 4-bit input port. P120 can be set to analog input. For only P120, input/output can be specified in 1-bit units. For only P120, use of an on-chip pull-up resistor can be specified by a software setting.	Analog input port	ANI19
P121	Input		Input port	X1
P122				X2/EXCLK
P123				XT1
P124				XT2/EXCLKS
P137	Input	Port 13. 1-bit input port.	Input port	INTP0
P146	I/O	Port 14. 2-bit I/O port. P147 can be set to analog input. Input/output can be specified in 1-bit units. Use of an on-chip pull-up resistor can be specified by a software setting.	Input port	–
P147			Analog input port	ANI18

## &lt;R&gt; 2.1.9 48-pin products

(1/2)

Function Name	I/O	Function	After Reset	Alternate Function
P00	I/O	Port 0. 2-bit I/O port. Input of P01 can be set to TTL input buffer. Output of P00 can be set to N-ch open-drain output ( $V_{DD}$ tolerance). Input/output can be specified in 1-bit units. Use of an on-chip pull-up resistor can be specified by a software setting.	Input port	TI00/TxD1
P01				TO00/RxD1
P10	I/O	Port 1. 8-bit I/O port. Input of P10, P11, and P13 to P17 can be set to TTL input buffer. Output of P10 to P15, and P17 can be set to N-ch open-drain output ( $V_{DD}$ tolerance). Input/output can be specified in 1-bit units. Use of an on-chip pull-up resistor can be specified by a software setting.	Input port	SCK00/SCL00/(TI07)/(TO07)
P11				SI00/RxD0/TOOLRxD/SDA00/(TI06)/(TO06)
P12				SO00/TxD0/TOOLTxD/(TI05)/(TO05)
P13				TxD2/SO20/(SDAA0)/(TI04)/(TO04)
P14				RxD2/SI20/SDA20/(SCLA0)/(TI03)/(TO03)
P15				PCLBUZ1/SCK20/SCL20/(TI02)/(TO02)
P16				TI01/TO01/INTP5/(RxD0)
P17				TI02/TO02/(TxD0)
P20	I/O	Port 2. 8-bit I/O port. Input/output can be specified in 1-bit units.	Analog input port	ANI0/AV <sub>REFP</sub>
P21				ANI1/AV <sub>REFM</sub>
P22				ANI2
P23				ANI3
P24				ANI4
P25				ANI5
P26				ANI6
P27				ANI7
P30	I/O	Port 3. 2-bit I/O port. Input/output can be specified in 1-bit units. Use of an on-chip pull-up resistor can be specified by a software setting.	Input port	INTP3/RTC1HZ/SCK11/SCL11
P31				TI03/TO03/INTP4/(PCLBUZ0)
P40	I/O	Port 4. 2-bit I/O port. Input/output can be specified in 1-bit units. Use of an on-chip pull-up resistor can be specified by a software setting.	Input port	TOOL0
P41				TI07/TO07

**Remark** Functions in parentheses in the above figure can be assigned via settings in the peripheral I/O redirection register (PIOR).

(2/2)

Function Name	I/O	Function	After Reset	Alternate Function
P50	I/O	Port 5. 2-bit I/O port. Output of P50 can be set to N-ch open-drain output ( $V_{DD}$ tolerance). Input/output can be specified in 1-bit units. Use of an on-chip pull-up resistor can be specified by a software setting.	Input port	INTP1/SI11/SDA11
P51				INTP2/SO11
P60	I/O	Port 6. 4-bit I/O port. Output of P60 to P63 can be set to N-ch open-drain output (6 V tolerance). Input/output can be specified in 1-bit units.	Input port	SCLA0
P61				SDAA0
P62				–
P63				–
P70	I/O	Port 7. 6-bit I/O port. Output of P71 and P74 can be set to N-ch open-drain output ( $V_{DD}$ tolerance). Input/output can be specified in 1-bit units. Use of an on-chip pull-up resistor can be specified by a software setting.	Input port	KR0/SCK21/SCL21
P71				KR1/SI21/SDA21
P72				KR2/SO21
P73				KR3/SO01
P74				KR4/INTP8/SI01/ SDA01
P75				KR5/INTP9/SCK01/ SCL01
P120	I/O	Port 12. 1-bit I/O port and 4-bit input port. P120 can be set to analog input. For only P120, input/output can be specified in 1-bit units. For only P120, use of an on-chip pull-up resistor can be specified by a software setting.	Analog input port	ANI19
P121	Input		Input port	X1
P122				X2/EXCLK
P123				XT1
P124				XT2/EXCLKS
P130	Output	Port 13. 1-bit output port and 1-bit input port.	Output port	–
P137	Input	Input port	INTP0	
P140	I/O	Port 14. 3-bit I/O port. P147 can be set to analog input. Input/output can be specified in 1-bit units. Use of an on-chip pull-up resistor can be specified by a software setting.	Input port	PCLBUZ0/INTP6
P146				–
P147			Analog input port	ANI18

## &lt;R&gt; 2.1.10 52-pin products

(1/2)

Function Name	I/O	Function	After Reset	Alternate Function
P00	I/O	Port 0. 4-bit I/O port. Input of P01 and P03 can be set to TTL input buffer. Output of P00 and P02 can be set to N-ch open-drain output ( $V_{DD}$ tolerance). P02 and P03 can be set to analog input. Input/output can be specified in 1-bit units. Use of an on-chip pull-up resistor can be specified by a software setting.	Input port	TI00
P01				TO00
P02			Analog input port	ANI17/TxD1
P03				ANI16/RxD1
P10	I/O	Port 1. 8-bit I/O port. Input of P10, P11, and P13 to P17 can be set to TTL input buffer. Output of P10 to P15, and P17 can be set to N-ch open-drain output ( $V_{DD}$ tolerance). Input/output can be specified in 1-bit units. Use of an on-chip pull-up resistor can be specified by a software setting.	Input port	SCK00/SCL00/(TI07)/(TO07)
P11				SI00/RxD0/TOOLRxD/SDA00/(TI06)/(TO06)
P12				SO00/TxD0/TOOLTxD/(TI05)/(TO05)
P13				TxD2/SO20/(SDAA0)/(TI04)/(TO04)
P14				RxD2/SI20/SDA20/(SCLA0)/(TI03)/(TO03)
P15				PCLBUZ1/SCK20/SCL20/(TI02)/(TO02)
P16				TI01/TO01/INTP5/(RxD0)
P17				TI02/TO02/(TxD0)
P20	I/O	Port 2. 8-bit I/O port. Input/output can be specified in 1-bit units.	Analog input port	ANI0/AV <sub>REFP</sub>
P21				ANI1/AV <sub>REFM</sub>
P22				ANI2
P23				ANI3
P24				ANI4
P25				ANI5
P26				ANI6
P27				ANI7
P30	I/O	Port 3. 2-bit I/O port. Input/output can be specified in 1-bit units. Use of an on-chip pull-up resistor can be specified by a software setting.	Input port	INTP3/RTC1HZ/SCK11/SCL11
P31				TI03/TO03/INTP4/(PCLBUZ0)
P40	I/O	Port 4. 2-bit I/O port. Input/output can be specified in 1-bit units. Use of an on-chip pull-up resistor can be specified by a software setting.	Input port	TOOL0
P41				TI07/TO07

**Remark** Functions in parentheses in the above figure can be assigned via settings in the peripheral I/O redirection register (PIOR).

(2/2)

Function Name	I/O	Function	After Reset	Alternate Function
P50	I/O	Port 5. 2-bit I/O port. Output of P50 can be set to N-ch open-drain output ( $V_{DD}$ tolerance). Input/output can be specified in 1-bit units. Use of an on-chip pull-up resistor can be specified by a software setting.	Input port	INTP1/SI11/SDA11
P51				INTP2/SO11
P60	I/O	Port 6. 4-bit I/O port. Output of P60 to P63 can be set to N-ch open-drain output (6 V tolerance). Input/output can be specified in 1-bit units.	Input port	SCLA0
P61				SDAA0
P62				–
P63				–
P70	I/O	Port 7. 8-bit I/O port. Output of P71 and P74 can be set to N-ch open-drain output ( $V_{DD}$ tolerance). Input/output can be specified in 1-bit units. Use of an on-chip pull-up resistor can be specified by a software setting.	Input port	KR0/SCK21/SCL21
P71				KR1/SI21/SDA21
P72				KR2/SO21
P73				KR3/SO01
P74				KR4/INTP8/SI01/ SDA01
P75				KR5/INTP9/SCK01/ SCL01
P76				KR6/INTP10/(Rx/D2)
P77				KR7/INTP11/(Tx/D2)
P120	I/O	Port 12. 1-bit I/O port and 4-bit input port. P120 can be set to analog input. For only P120, input/output can be specified in 1-bit units. For only P120, use of an on-chip pull-up resistor can be specified by a software setting.	Analog input port	ANI19
P121	Input		Input port	X1
P122				X2/EXCLK
P123				XT1
P124				XT2/EXCLKS
P130	Output	Port 13. 1-bit output port and 1-bit input port.	Output port	–
P137	Input	Input port	INTP0	
P140	I/O	Port 14. 3-bit I/O port. P147 can be set to analog input. Input/output can be specified in 1-bit units. Use of an on-chip pull-up resistor can be specified by a software setting.	Input port	PCLBUZ0/INTP6
P146				–
P147			Analog input port	ANI18

**Remark** Functions in parentheses in the above figure can be assigned via settings in the peripheral I/O redirection register (PIOR).



## &lt;R&gt; 2.1.11 64-pin products

(1/2)

Function Name	I/O	Function	After Reset	Alternate Function
P00	I/O	Port 0. 7-bit I/O port. Input of P01, P03, and P04 can be set to TTL input buffer. Output of P00 and P02 to P04 can be set to N-ch open-drain output ( $V_{DD}$ tolerance). P02 and P03 can be set to analog input. Input/output can be specified in 1-bit units. Use of an on-chip pull-up resistor can be specified by a software setting.	Input port	TI00
P01				TO00
P02			Analog input port	ANI17/SO10/TxD1
P03				ANI16/SI10/RxD1/ SDA10
P04			Input port	SCK10/SCL10
P05				TI05/TO05
P06				TI06/TO06
P10	I/O	Port 1. 8-bit I/O port. Input of P10, P11, and P13 to P17 can be set to TTL input buffer. Output of P10 to P15, and P17 can be set to N-ch open-drain output ( $V_{DD}$ tolerance). Input/output can be specified in 1-bit units. Use of an on-chip pull-up resistor can be specified by a software setting.	Input port	SCK00/SCL00/(TI07)/ (TO07)
P11				SI00/RxD0/ TOOLRxD/SDA00/ (TI06)/(TO06)
P12				SO00/TxD0/TOOLTxD /(INTP5)/(TI05)/(TO05)
P13				TxD2/SO20/(SDAA0)/ (TI04)/(TO04)
P14				RxD2/SI20/SDA20/ (SCLA0)/(TI03)/ (TO03)
P15				SCK20/SCL20/(TI02)/ (TO02)
P16				TI01/TO01/INTP5/ (SI00)/(RxD0)
P17	TI02/TO02/(SO00)/ (TxD0)			
P20	I/O	Port 2. 8-bit I/O port. Input/output can be specified in 1-bit units.	Analog input port	ANI0/AV <sub>REFP</sub>
P21				ANI1/AV <sub>REFM</sub>
P22				ANI2
P23				ANI3
P24				ANI4
P25				ANI5
P26				ANI6
P27	ANI7			
P30	I/O	Port 3. 2-bit I/O port. Input/output can be specified in 1-bit units. Use of an on-chip pull-up resistor can be specified by a software setting.	Input port	INTP3/RTC1HZ/ SCK11/SCL11
P31				TI03/TO03/INTP4 /(PCLBUZ0)
P40	I/O	Port 4. 4-bit I/O port. Input/output can be specified in 1-bit units. Use of an on-chip pull-up resistor can be specified by a software setting.	Input port	TOOL0
P41				TI07/TO07
P42				TI04/TO04
P43				–

**Remark** Functions in parentheses in the above figure can be assigned via settings in the peripheral I/O redirection register (PIOR).

(2/2)

Function Name	I/O	Function	After Reset	Alternate Function
P50	I/O	Port 5. 6-bit I/O port. Output of P50 can be set to N-ch open-drain output ( $V_{DD}$ tolerance). Input/output can be specified in 1-bit units. Use of an on-chip pull-up resistor can be specified by a software setting.	Input port	INTP1/SI11/SDA11
P51				INTP2/SO11
P52				(INTP10)
P53				(INTP11)
P54				–
P55				(PCLBUZ1)/(SCK00)
P60	I/O	Port 6. 4-bit I/O port. Output of P60 to P63 can be set to N-ch open-drain output (6 V tolerance). Input/output can be specified in 1-bit units.	Input port	SCLA0
P61				SDAA0
P62				–
P63				–
P70	I/O	Port 7. 8-bit I/O port. Output of P71 and P74 can be set to N-ch open-drain output ( $V_{DD}$ tolerance). Input/output can be specified in 1-bit units. Use of an on-chip pull-up resistor can be specified by a software setting.	Input port	KR0/SCK21/SCL21
P71				KR1/SI21/SDA21
P72				KR2/SO21
P73				KR3/SO01
P74				KR4/INTP8/SI01/ SDA01
P75				KR5/INTP9/SCK01/ SCL01
P76				KR6/INTP10/(RxD2)
P77				KR7/INTP11/(TxD2)
P120	I/O	Port 12. 1-bit I/O port and 4-bit input port. P120 can be set to analog input. For only P120, input/output can be specified in 1-bit units. For only P120, use of an on-chip pull-up resistor can be specified by a software setting.	Analog input port	ANI19
P121	Input		Input port	X1
P122				X2/EXCLK
P123				XT1
P124				XT2/EXCLKS
P130	Output	Port 13. 1-bit output port and 1-bit input port.	Output port	–
P137	Input	Input port	INTP0	
P140	I/O	Port 14. 4-bit I/O port. P147 can be set to analog input. Input/output can be specified in 1-bit units. Use of an on-chip pull-up resistor can be specified by a software setting.	Input port	PCLBUZ0/INTP6
P141				PCLBUZ1/INTP7
P146				–
P147			Analog input port	ANI18

**Remark** Functions in parentheses in the above figure can be assigned via settings in the peripheral I/O redirection register (PIOR).

## &lt;R&gt; 2.1.12 80-pin products

(1/3)

Function Name	I/O	Function	After Reset	Alternate Function
P00	I/O	Port 0. 7-bit I/O port. Input of P01, P03 and P04 can be set to TTL input buffer. Output of P00, P02 to P04 can be set to N-ch open-drain output ( $V_{DD}$ tolerance). P02 and P03 can be set to analog input. Input/output can be specified in 1-bit units. Use of an on-chip pull-up resistor can be specified by a software setting.	Input port	TI00
P01				TO00
P02			Analog input port	ANI17/SO10/TxD1
P03				ANI16/SI10/RxD1/ SDA10
P04			Input port	SCK10/SCL10
P05				TI05/TO05
P06				TI06/TO06
P10	I/O	Port 1. 8-bit I/O port. Input of P10, P11, and P13 to P17 can be set to TTL input buffer. Output of P10 to P15, and P17 can be set to N-ch open-drain output ( $V_{DD}$ tolerance). Input/output can be specified in 1-bit units. Use of an on-chip pull-up resistor can be specified by a software setting.	Input port	SCK00/SCL00/(TI07)/ (TO07)
P11				SI00/RxD0/ TOOLRxD/SDA00/ (TI06)/(TO06)
P12				SO00/TxD0/TOOLTxD /(INTP5)/(TI05)/(TO05)
P13				TxD2/SO20/(SDAA0)/ (TI04)/(TO04)
P14				RxD2/SI20/SDA20/ (SCLA0)/(TI03)/ (TO03)
P15				SCK20/SCL20/(TI02)/ (TO02)
P16				TI01/TO01/INTP5/ (SI00)/(RxD0)
P17				TI02/TO02/(SO00)/ (TxD0)
P20	I/O	Port 2. 8-bit I/O port. Input/output can be specified in 1-bit units.	Analog input port	ANI0/AV <sub>REFP</sub>
P21				ANI1/AV <sub>REFM</sub>
P22				ANI2
P23				ANI3
P24				ANI4
P25				ANI5
P26				ANI6
P27				ANI7
P30	I/O	Port 3. 2-bit I/O port. Input/output can be specified in 1-bit units. Use of an on-chip pull-up resistor can be specified by a software setting.	Input port	INTP3/RTC1HZ/ SCK11/SCL11
P31				TI03/TO03/INTP4/ (PCLBUZ0)

**Remark** Functions in parentheses in the above figure can be assigned via settings in the peripheral I/O redirection register (PIOR).

(2/3)

Function Name	I/O	Function	After Reset	Alternate Function
P40	I/O	Port 4. 6-bit I/O port. Input of P43 and P44 can be set to TTL input buffer. Output of P43 to P45 can be set to N-ch open-drain output ( $V_{DD}$ tolerance). Input/output can be specified in 1-bit units. Use of an on-chip pull-up resistor can be specified by a software setting.	Input port	TOOL0
P41				TI07/TO07
P42				TI04/TO04
P43				SCK01/SCL01
P44				SI01/SDA01
P45				SO01
P50	I/O	Port 5. 6-bit I/O port. Input of P53 to P55 can be set to TTL input buffer. Output of P50, P52 to P55 can be set to N-ch open-drain output ( $V_{DD}$ tolerance). Input/output can be specified in 1-bit units. Use of an on-chip pull-up resistor can be specified by a software setting.	Input port	INTP1/SI11/SDA11
P51				INTP2/SO11
P52				SO31
P53				SI31/SDA31
P54				SCK31/SCL31
P55				(PCLBUZ1)/(SCK00)
P60	I/O	Port 6. 8-bit I/O port. Output of P60 to P63 can be set to N-ch open-drain output (6 V tolerance). Input/output can be specified in 1-bit units. For P64 to P67, use of an on-chip pull-up resistor can be specified by a software setting.	Input port	SCLA0
P61				SDAA0
P62				SCLA1
P63				SDAA1
P64				TI10/TO10
P65				TI11/TO11
P66				TI12/TO12
P67				TI13/TO13
P70	I/O	Port 7. 8-bit I/O port. Output of P71 and P74 can be set to N-ch open-drain output ( $V_{DD}$ tolerance). Input/output can be specified in 1-bit units. Use of an on-chip pull-up resistor can be specified by a software setting.	Input port	KR0/SCK21/SCL21
P71				KR1/SI21/SDA21
P72				KR2/SO21
P73				KR3
P74				KR4/INTP8
P75				KR5/INTP9
P76				KR6/INTP10/(RxD2)
P77				KR7/INTP11/(TxD2)
P100	I/O	Port 10. 1-bit I/O port. P100 can be set to analog input.	Analog input port	ANI20
P110	I/O	Port 11. 2-bit I/O port.	Input port	(INTP10)
P111				(INTP11)
P120	I/O	Port 12. 1-bit I/O port and 4-bit input port. P120 can be set to analog input.	Analog input port	ANI19
P121	Input	For only P120, input/output can be specified in 1-bit units. For only P120, use of an on-chip pull-up resistor can be specified by a software setting.	Input port	X1
P122				X2/EXCLK
P123				XT1
P124				XT2/EXCLKS

**Remark** Functions in parentheses in the above figure can be assigned via settings in the peripheral I/O redirection register (PIOR).

(3/3)

Function Name	I/O	Function	After Reset	Alternate Function
P130	Output	Port 13.	Output port	–
P137	Input	1-bit output port and 1-bit input port.	Input port	INTP0
P140	I/O	Port 14. 7-bit I/O port. Input of P142 and P143 can be set to TTL input buffer. Output of P142 to P144 can be set to N-ch open-drain output ( $V_{DD}$ tolerance). P147 can be set to analog input. Input/output can be specified in 1-bit units. Use of an on-chip pull-up resistor can be specified by a software setting.	Input port	PCLBUZ0/INTP6
P141				PCLBUZ1/INTP7
P142				SCK30/SCL30
P143				SI30/RxD3/SDA30
P144				SO30/TxD3
P146				–
P147			Analog input port	ANI18
P150			I/O	Port 15. 4-bit I/O port. Input/output can be specified in 1-bit units.
P151	ANI9			
P152	ANI10			
P153	ANI11			

## &lt;R&gt; 2.1.13 100-pin products

(1/3)

Function Name	I/O	Function	After Reset	Alternate Function
P00	I/O	Port 0. 7-bit I/O port. Input of P01, P03 and P04 can be set to TTL input buffer. Output of P00, P02 to P04 can be set to N-ch open-drain output ( $V_{DD}$ tolerance). P02 and P03 can be set to analog input. Input/output can be specified in 1-bit units. Use of an on-chip pull-up resistor can be specified by a software setting.	Input port	TI00
P01				TO00
P02			Analog input port	ANI17/SO10/TxD1
P03				ANI16/SI10/RxD1/ SDA10
P04			Input port	SCK10/SCL10
P05			–	
P06			–	
P10	I/O	Port 1. 8-bit I/O port. Input of P10, P11, and P13 to P17 can be set to TTL input buffer. Output of P10 to P15, and P17 can be set to N-ch open-drain output ( $V_{DD}$ tolerance). Input/output can be specified in 1-bit units. Use of an on-chip pull-up resistor can be specified by a software setting.	Input port	SCK00/SCL00/(TI07)/ (TO07)
P11				SI00/RxD0/ TOOLRxD/SDA00/ (TI06)/(TO06)
P12				SO00/TxD0/TOOLTxD /(INTP5)/(TI05)/(TO05)
P13				TxD2/SO20/(SDAA0)/ (TI04)/(TO04)
P14				RxD2/SI20/SDA20/ (SCLA0)/(TI03)/ (TO03)
P15				SCK20/SCL20/(TI02)/ (TO02)
P16				TI01/TO01/INTP5/ (SI00)/(RxD0)
P17				TI02/TO02/(SO00)/ (TxD0)
P20	I/O	Port 2. 8-bit I/O port. Input/output can be specified in 1-bit units.	Analog input port	ANI0/AV <sub>REFP</sub>
P21				ANI1/AV <sub>REFM</sub>
P22				ANI2
P23				ANI3
P24				ANI4
P25				ANI5
P26				ANI6
P27				ANI7
P30	I/O	Port 3. 2-bit I/O port. Input/output can be specified in 1-bit units. Use of an on-chip pull-up resistor can be specified by a software setting.	Input port	INTP3/RTC1HZ/ SCK11/SCL11
P31				TI03/TO03/INTP4/ (PCLBUZ0)

**Remark** Functions in parentheses in the above figure can be assigned via settings in the peripheral I/O redirection register (PIOR).

(2/3)

Function Name	I/O	Function	After Reset	Alternate Function
P40	I/O	Port 4. 8-bit I/O port. Input of P43 and P44 can be set to TTL input buffer. Output of P43 to P45 can be set to N-ch open-drain output ( $V_{DD}$ tolerance). Input/output can be specified in 1-bit units. Use of an on-chip pull-up resistor can be specified by a software setting.	Input port	TOOL0
P41				–
P42				TI04/TO04
P43				SCK01/SCL01
P44				SI01/SDA01
P45				SO01
P46				INTP1/TI05/TO05
P47				INTP2
P50	I/O	Port 5. 8-bit I/O port. Input of P53 to P55 can be set to TTL input buffer. Output of P50, P52 to P55 can be set to N-ch open-drain output ( $V_{DD}$ tolerance). Input/output can be specified in 1-bit units. Use of an on-chip pull-up resistor can be specified by a software setting.	Input port	SI11/SDA11
P51				SO11
P52				SO31
P53				SI31/SDA31
P54				SCK31/SCL31
P55				(PCLBUZ1)/(SCK00)
P56				(INTP1)
P57				(INTP3)
P60	I/O	Port 6. 8-bit I/O port. Output of P60 to P63 can be set to N-ch open-drain output (6 V tolerance). Input/output can be specified in 1-bit units. For P64 to P67, use of an on-chip pull-up resistor can be specified by a software setting.	Input port	SCLA0
P61				SDAA0
P62				SCLA1
P63				SDAA1
P64				TI10/TO10
P65				TI11/TO11
P66				TI12/TO12
P67				TI13/TO13
P70	I/O	Port 7. 8-bit I/O port. Output of P71 and P74 can be set to N-ch open-drain output ( $V_{DD}$ tolerance). Input/output can be specified in 1-bit units. Use of an on-chip pull-up resistor can be specified by a software setting.	Input port	KR0/SCK21/SCL21
P71				KR1/SI21/SDA21
P72				KR2/SO21
P73				KR3
P74				KR4/INTP8
P75				KR5/INTP9
P76				KR6/INTP10/(RxD2)
P77				KR7/INTP11/(TxD2)
P80	I/O	Port 8. 8-bit I/O port. Input of P80 and P81 can be set to TTL input buffer. Output of P80 to P82 can be set to N-ch open-drain output ( $V_{DD}$ tolerance). Input/output can be specified in 1-bit units. Use of an on-chip pull-up resistor can be specified by a software setting.	Input port	(SCK10)/(SCL10)
P81				(SI10)/(RxD1)/(SDA10)
P82				(SO10)/(TxD1)
P83				–
P84				(INTP6)
P85				(INTP7)
P86				(INTP8)
P87				(INTP9)

**Remark** Functions in parentheses in the above figure can be assigned via settings in the peripheral I/O redirection register (PIOR).

(3/3)

Function Name	I/O	Function	After Reset	Alternate Function
P100	I/O	Port 10. 3-bit I/O port.  P100 can be set to analog input.	Analog input port	ANI20
P101			Input port	–
P102				TI06/TO06
P110	I/O	Port 11. 2-bit I/O port.	Input port	(INTP10)
P111				(INTP11)
P120	I/O	Port 12. 1-bit I/O port and 4-bit input port.  P120 can be set to analog input. For only P120, input/output can be specified in 1-bit units. For only P120, use of an on-chip pull-up resistor can be specified by a software setting.	Analog input port	ANI19
P121			Input port	X1
P122				X2/EXCLK
P123				XT1
P124				XT2/EXCLKS
P130	Output	Port 13. 1-bit output port and 1-bit input port.	Output port	–
P137	Input		Input port	INTP0
P140	I/O	Port 14. 8-bit I/O port. Input of P142 and P143 can be set to TTL input buffer. Output of P142 to P144 can be set to N-ch open-drain output ( $V_{DD}$ tolerance). P147 can be set to analog input. Input/output can be specified in 1-bit units. Use of an on-chip pull-up resistor can be specified by a software setting.	Input port	PCLBUZ0/INTP6
P141				PCLBUZ1/INTP7
P142				SCK30/SCL30
P143				SI30/RxD3/SDA30
P144				SO30/TxD3
P145				TI07/TO07
P146				(INTP4)
P147				Analog input port
P150			I/O	Port 15. 7-bit I/O port. Input/output can be specified in 1-bit units.
P151	ANI9			
P152	ANI10			
P153	ANI11			
P154	ANI12			
P155	ANI13			
P156	ANI14			

**Remark** Functions in parentheses in the above figure can be assigned via settings in the peripheral I/O redirection register (PIOR).



<R> 2.1.14 128-pin products

(1/4)

Function Name	I/O	Function	After Reset	Alternate Function
P00	I/O	Port 0. 8-bit I/O port. Input of P01, P03 and P04 can be set to TTL input buffer. Output of P00, P02 to P04 can be set to N-ch open-drain output ( $V_{DD}$ tolerance). P02 and P03 can be set to analog input. Input/output can be specified in 1-bit units. Use of an on-chip pull-up resistor can be specified by a software setting.	Input port	TI00
P01				TO00
P02			Analog input port	ANI17/SO10/TxD1
P03				ANI16/SI10/RxD1/ SDA10
P04			Input port	SCK10/SCL10
P05				-
P06				-
P07				-
P10	I/O	Port 1. 8-bit I/O port. Input of P10, P11, and P13 to P17 can be set to TTL input buffer. Output of P10 to P15, and P17 can be set to N-ch open-drain output ( $V_{DD}$ tolerance). Input/output can be specified in 1-bit units. Use of an on-chip pull-up resistor can be specified by a software setting.		Input port
P11			SI00/RxD0/ TOOLRxD/SDA00/ (TI06)/(TO06)	
P12			SO00/TxD0/TOOLTxD /(INTP5)/(TI05)/(TO05)	
P13			TxD2/SO20/(SDAA0)/ (TI04)/(TO04)	
P14			RxD2/SI20/SDA20/ (SCLA0)/(TI03)/ (TO03)	
P15			SCK20/SCL20/(TI02)/ (TO02)	
P16			TI01/TO01/INTP5/ (SI00)/(RxD0)	
P17			TI02/TO02/(SO00)/ (TxD0)	
P20	I/O	Port 2. 8-bit I/O port. Input/output can be specified in 1-bit units.	Analog input port	ANI0/AV <sub>REFP</sub>
P21				ANI1/AV <sub>REFM</sub>
P22				ANI2
P23				ANI3
P24				ANI4
P25				ANI5
P26				ANI6
P27				ANI7

**Remark** Functions in parentheses in the above figure can be assigned via settings in the peripheral I/O redirection register (PIOR).

(2/4)

Function Name	I/O	Function	After Reset	Alternate Function
P30	I/O	Port 3. 8-bit I/O port. P35 to P37 can be set to analog input. Input/output can be specified in 1-bit units. Use of an on-chip pull-up resistor can be specified by a software setting.	Input port	INTP3/RTC1HZ
P31				TI03/TO03/INTP4/ (PCLBUZ0)
P32				–
P33				–
P34			–	
P35			Analog input port	ANI23
P36				ANI22
P37				ANI21
P40	I/O	Port 4. 8-bit I/O port. Input of P43 and P44 can be set to TTL input buffer. Output of P43 to P45 can be set to N-ch open-drain output ( $V_{DD}$ tolerance). Input/output can be specified in 1-bit units. Use of an on-chip pull-up resistor can be specified by a software setting.	Input port	TOOL0
P41				–
P42				TI04/TO04
P43				SCK01/SCL01
P44				SI01/SDA01
P45				SO01
P46				INTP1/TI05/TO05
P47				INTP2
P50	I/O	Port 5. 8-bit I/O port. Input of P53 to P55 can be set to TTL input buffer. Output of P50, P52 to P55 can be set to N-ch open-drain output ( $V_{DD}$ tolerance). Input/output can be specified in 1-bit units. Use of an on-chip pull-up resistor can be specified by a software setting.	Input port	–
P51				–
P52				SO31
P53				SI31/SDA31
P54				SCK31/SCL31
P55				(PCLBUZ1)/(SCK00)
P56				(INTP1)
P57				(INTP3)
P60	I/O	Port 6. 8-bit I/O port. Output of P60 to P63 can be set to N-ch open-drain output (6 V tolerance). Input/output can be specified in 1-bit units. For P64 to P67, use of an on-chip pull-up resistor can be specified by a software setting.	Input port	SCLA0
P61				SDA00
P62				SCLA1
P63				SDAA1
P64				TI10/TO10
P65				TI11/TO11
P66				TI12/TO12
P67				TI13/TO13

**Remark** Functions in parentheses in the above figure can be assigned via settings in the peripheral I/O redirection register (PIOR).

(3/4)

Function Name	I/O	Function	After Reset	Alternate Function
P70	I/O	Port 7. 8-bit I/O port. Output of P71 and P74 can be set to N-ch open-drain output ( $V_{DD}$ tolerance). Input/output can be specified in 1-bit units. Use of an on-chip pull-up resistor can be specified by a software setting.	Input port	KR0/SCK21/SCL21
P71				KR1/SI21/SDA21
P72				KR2/SO21
P73				KR3
P74				KR4/INTP8
P75				KR5/INTP9
P76				KR6/INTP10/(RxD2)
P77				KR7/INTP11/(TxD2)
P80	I/O	Port 8. 8-bit I/O port. Input of P80 and P81 can be set to TTL input buffer. Output of P80 to P82 can be set to N-ch open-drain output ( $V_{DD}$ tolerance). Input/output can be specified in 1-bit units. Use of an on-chip pull-up resistor can be specified by a software setting.		(SCK10)/(SCL10)
P81				(SI10)/(RxD1)/(SDA10)
P82				(SO10)/(TxD1)
P83				–
P84				(INTP6)
P85				(INTP7)
P86				(INTP8)
P87				(INTP9)
P90	I/O	Port 9. 8-bit I/O port. Output of P96 can be set to N-ch open-drain output ( $V_{DD}$ tolerance). Input/output can be specified in 1-bit units. Use of an on-chip pull-up resistor can be specified by a software setting.	Input port	–
P91				–
P92				–
P93				–
P94				–
P95				SCK11/SCL11
P96				SI11/SDA11
P97				SO11
P100	I/O	Port 10. 7-bit I/O port. P100 can be set to analog input. Input/output can be specified in 1-bit units. Use of an on-chip pull-up resistor can be specified by a software setting.	Analog input port	ANI20
P101			Input port	–
P102				TI06/TO06
P103				TI14/TO14
P104				TI15/TO15
P105				TI16/TO16
P106				TI17/TO17
P110	I/O	Port 11. 8-bit I/O port. P115 to P117 can be set to analog input. Input/output can be specified in 1-bit units. Use of an on-chip pull-up resistor can be specified by a software setting.	Input port	(INTP10)
P111				(INTP11)
P112				–
P113				–
P114			–	
P115			Analog input port	ANI26
P116				ANI25
P117	ANI24			

**Remark** Functions in parentheses in the above figure can be assigned via settings in the peripheral I/O redirection register (PIOR).

(4/4)

Function Name	I/O	Function	After Reset	Alternate Function
P120	I/O	Port 12. 4-bit I/O port and 4-bit input port. P120 can be set to analog input. For only P120, P125 to P127, input/output can be specified in 1-bit units. For only P120, P125 to P127, use of an on-chip pull-up resistor can be specified by a software setting.	Analog input port	ANI19
P121	Input		Input port	X1
P122				X2/EXCLK
P123				XT1
P124				XT2/EXCLKS
P125	I/O			–
P126				–
P127				–
P130	Output	Port 13.		Output port
P137	Input	1-bit output port and 1-bit input port.	Input port	INTP0
P140	I/O	Port 14. 8-bit I/O port. Input of P142 and P143 can be set to TTL input buffer. Output of P142 to P144 can be set to N-ch open-drain output ( $V_{DD}$ tolerance). P147 can be set to analog input. Input/output can be specified in 1-bit units. Use of an on-chip pull-up resistor can be specified by a software setting.	Input port	PCLBUZ0/INTP6
P141				PCLBUZ1/INTP7
P142				SCK30/SCL30
P143				SI30/RxD3/SDA30
P144				SO30/TxD3
P145				TI07/TO07
P146				(INTP4)
P147			Analog input port	ANI18
P150	I/O	Port 15. 7-bit I/O port. Input/output can be specified in 1-bit units.	Analog input port	ANI8
P151				ANI9
P152				ANI10
P153				ANI11
P154				ANI12
P155				ANI13
P156				ANI14

**Remark** Functions in parentheses in the above figure can be assigned via settings in the peripheral I/O redirection register (PIOR).

2.1.15 Pins for each product (pins other than port pins)

(1/6)

Function Name	I/O	Function	128-pin	100-pin	80-pin	64-pin	52-pin	48-pin	44-pin	40-pin	36-pin	32-pin	30-pin	25-pin	24-pin	20-pin	
ANI0	Input	A/D converter analog input	√	√	√	√	√	√	√	√	√	√	√	√	√	√	
ANI1			√	√	√	√	√	√	√	√	√	√	√	√	√	√	√
ANI2			√	√	√	√	√	√	√	√	√	√	√	√	√	√	√
ANI3			√	√	√	√	√	√	√	√	√	√	√	√	-	-	-
ANI4			√	√	√	√	√	√	√	√	√	√	-	-	-	-	-
ANI5			√	√	√	√	√	√	√	√	√	√	-	-	-	-	-
ANI6			√	√	√	√	√	√	√	√	√	√	-	-	-	-	-
ANI7			√	√	√	√	√	√	√	√	√	-	-	-	-	-	-
ANI8			√	√	√	-	-	-	-	-	-	-	-	-	-	-	-
ANI9			√	√	√	-	-	-	-	-	-	-	-	-	-	-	-
ANI10			√	√	√	-	-	-	-	-	-	-	-	-	-	-	-
ANI11			√	√	√	-	-	-	-	-	-	-	-	-	-	-	-
ANI12			√	√	-	-	-	-	-	-	-	-	-	-	-	-	-
ANI13			√	√	-	-	-	-	-	-	-	-	-	-	-	-	-
ANI14			√	√	-	-	-	-	-	-	-	-	-	-	-	-	-
ANI16			√	√	√	√	√	√	-	-	-	-	√	√	√	√	√
ANI17			√	√	√	√	√	√	-	-	-	-	√	√	√	√	√
ANI18			√	√	√	√	√	√	√	√	√	√	√	√	√	√	√
ANI19			√	√	√	√	√	√	√	√	√	√	√	√	-	-	-
ANI20			√	√	√	-	-	-	-	-	-	-	-	-	-	-	-
ANI21			√	-	-	-	-	-	-	-	-	-	-	-	-	-	-
ANI22			√	-	-	-	-	-	-	-	-	-	-	-	-	-	-
ANI23			√	-	-	-	-	-	-	-	-	-	-	-	-	-	-
ANI24			√	-	-	-	-	-	-	-	-	-	-	-	-	-	-
ANI25			√	-	-	-	-	-	-	-	-	-	-	-	-	-	-
ANI26			√	-	-	-	-	-	-	-	-	-	-	-	-	-	-
INTP0	Input	External interrupt request input	√	√	√	√	√	√	√	√	√	√	√	√	√	√	
INTP1			√	√	√	√	√	√	√	√	√	√	√	√	√	√	-
INTP2			√	√	√	√	√	√	√	√	√	√	√	√	-	-	-
INTP3			√	√	√	√	√	√	√	√	√	√	√	√	√	√	√
INTP4			√	√	√	√	√	√	√	√	√	√	√	√	√	√	-
INTP5			√	√	√	√	√	√	√	√	√	√	√	√	√	√	√
INTP6			√	√	√	√	√	√	√	-	-	-	-	-	-	-	-
INTP7			√	√	√	√	-	-	-	-	-	-	-	-	-	-	-
INTP8			√	√	√	√	√	√	√	-	-	-	-	-	-	-	-
INTP9			√	√	√	√	√	√	√	-	-	-	-	-	-	-	-
INTP10			√	√	√	√	√	√	√	-	-	-	-	-	-	-	-
INTP11			√	√	√	√	√	√	√	-	-	-	-	-	-	-	-

(2/6)

<R>

Function Name	I/O	Function	128-pin	100-pin	80-pin	64-pin	52-pin	48-pin	44-pin	40-pin	36-pin	32-pin	30-pin	25-pin	24-pin	20-pin	
KR0	Input	Key interrupt input	√	√	√	√	√	√	√	√	-	-	-	-	-	-	
KR1			√	√	√	√	√	√	√	√	-	-	-	-	-	-	
KR2			√	√	√	√	√	√	√	√	-	-	-	-	-	-	
KR3			√	√	√	√	√	√	√	√	-	-	-	-	-	-	
KR4			√	√	√	√	√	√	-	-	-	-	-	-	-	-	
KR5			√	√	√	√	√	√	-	-	-	-	-	-	-	-	
KR6			√	√	√	√	√	-	-	-	-	-	-	-	-	-	
KR7			√	√	√	√	√	-	-	-	-	-	-	-	-	-	
PCLBUZ0	Output	Clock output/buzzer output	√	√	√	√	√	√	√	√	√	√	√	√	√	-	
PCLBUZ1			√	√	√	√	√	√	√	√	√	√	√	-	-	-	
REGC	-	Connecting regulator output stabilization capacitance for internal operation. Connect to V <sub>SS</sub> via a capacitor (0.47 to 1 μF).	√	√	√	√	√	√	√	√	√	√	√	√	√	√	
RTC1HZ	Output	Real-time clock correction clock (1 Hz) output	√	√	√	√	√	√	√	√	-	-	-	-	-	-	
RESET	Input	System reset input	√	√	√	√	√	√	√	√	√	√	√	√	√	√	
RxD0	Input	Serial data input to UART0	√	√	√	√	√	√	√	√	√	√	√	√	√	√	
RxD1		Serial data input to UART1	√	√	√	√	√	√	√	√	√	√	√	√	√	√	
RxD2		Serial data input to UART2	√	√	√	√	√	√	√	√	√	√	√	-	-	-	
RxD3		Serial data input to UART3	√	√	√	-	-	-	-	-	-	-	-	-	-	-	
SCK00	I/O	Clock input/output for CSI00, CSI01, CSI10, CSI11, CSI20, CSI21, CSI30, and CSI31	√	√	√	√	√	√	√	√	√	√	√	√	√	√	
SCK01			√	√	√	√	√	√	-	-	-	-	-	-	-	-	
SCK10			√	√	√	√	-	-	-	-	-	-	-	-	-	-	
SCK11			√	√	√	√	√	√	√	√	√	√	√	√	√	√	
SCK20			√	√	√	√	√	√	√	√	√	√	√	√	-	-	-
SCK21			√	√	√	√	√	√	√	√	√	√	-	-	-	-	-
SCK30			√	√	√	-	-	-	-	-	-	-	-	-	-	-	-
SCK31			√	√	√	-	-	-	-	-	-	-	-	-	-	-	-
SCLA0	I/O	Clock input/output for IICA0, IICA1	√	√	√	√	√	√	√	√	√	√	√	√	√	-	
SCLA1			√	√	√	-	-	-	-	-	-	-	-	-	-	-	

(3/6)

Function Name	I/O	Function	128-pin	100-pin	80-pin	64-pin	52-pin	48-pin	44-pin	40-pin	36-pin	32-pin	30-pin	25-pin	24-pin	20-pin	
SCL00	Output	Clock output for IIC00, IIC01, IIC10, IIC11, IIC20, IIC21, IIC30, IIC31	√	√	√	√	√	√	√	√	√	√	√	√	√	√	
SCL01			√	√	√	√	√	√	-	-	-	-	-	-	-	-	
SCL10			√	√	√	√	-	-	-	-	-	-	-	-	-	-	-
SCL11			√	√	√	√	√	√	√	√	√	√	√	√	√	√	√
SCL20			√	√	√	√	√	√	√	√	√	√	√	√	-	-	-
SCL21			√	√	√	√	√	√	√	√	√	√	-	-	-	-	-
SCL30			√	√	√	-	-	-	-	-	-	-	-	-	-	-	-
SCL31			√	√	√	-	-	-	-	-	-	-	-	-	-	-	-
SDAA0	I/O	Serial data I/O for IICA0, IICA1	√	√	√	√	√	√	√	√	√	√	√	√	√	-	
SDAA1			√	√	√	-	-	-	-	-	-	-	-	-	-	-	
SDA00	I/O	Serial data I/O for IIC00, IIC01, IIC10, IIC11, IIC20, IIC21, IIC30, IIC31	√	√	√	√	√	√	√	√	√	√	√	√	√	√	
SDA01			√	√	√	√	√	√	-	-	-	-	-	-	-	-	
SDA10			√	√	√	√	-	-	-	-	-	-	-	-	-	-	-
SDA11			√	√	√	√	√	√	√	√	√	√	√	√	√	√	√
SDA20			√	√	√	√	√	√	√	√	√	√	√	√	-	-	-
SDA21			√	√	√	√	√	√	√	√	√	√	-	-	-	-	-
SDA30			√	√	√	-	-	-	-	-	-	-	-	-	-	-	-
SDA31			√	√	√	-	-	-	-	-	-	-	-	-	-	-	-
SI00	Input	Serial data input to CSI00, CSI01, CSI10, CSI11, CSI20, CSI21, CSI30, and CSI31	√	√	√	√	√	√	√	√	√	√	√	√	√	√	
SI01			√	√	√	√	√	√	-	-	-	-	-	-	-	-	
SI10			√	√	√	√	-	-	-	-	-	-	-	-	-	-	-
SI11			√	√	√	√	√	√	√	√	√	√	√	√	√	√	√
SI20			√	√	√	√	√	√	√	√	√	√	√	√	-	-	-
SI21			√	√	√	√	√	√	√	√	√	√	-	-	-	-	-
SI30			√	√	√	-	-	-	-	-	-	-	-	-	-	-	-
SI31			√	√	√	-	-	-	-	-	-	-	-	-	-	-	-
SO00	Output	Serial data output from CSI00, CSI01, CSI10, CSI11, CSI20, CSI21, CSI30, and CSI31	√	√	√	√	√	√	√	√	√	√	√	√	√	√	
SO01			√	√	√	√	√	√	-	-	-	-	-	-	-	-	
SO10			√	√	√	√	-	-	-	-	-	-	-	-	-	-	-
SO11			√	√	√	√	√	√	√	√	√	√	√	√	√	√	√
SO20			√	√	√	√	√	√	√	√	√	√	√	√	-	-	-
SO21			√	√	√	√	√	√	√	√	√	√	-	-	-	-	-
SO30			√	√	√	-	-	-	-	-	-	-	-	-	-	-	-
SO31			√	√	√	-	-	-	-	-	-	-	-	-	-	-	-

(4/6)

Function Name	I/O	Function	128-pin	100-pin	80-pin	64-pin	52-pin	48-pin	44-pin	40-pin	36-pin	32-pin	30-pin	25-pin	24-pin	20-pin
TI00	Input	External count clock input to 16-bit timer 00	√	√	√	√	√	√	√	√	√	√	√	√	√	√
TI01		External count clock input to 16-bit timer 01	√	√	√	√	√	√	√	√	√	√	√	√	√	√
TI02		External count clock input to 16-bit timer 02	√	√	√	√	√	√	√	√	√	√	√	√	√	√
TI03		External count clock input to 16-bit timer 03	√	√	√	√	√	√	√	√	√	√	√	√	√	√
TI04		External count clock input to 16-bit timer 04	√	√	√	√	-	-	-	-	-	-	-	-	-	-
TI05		External count clock input to 16-bit timer 05	√	√	√	√	-	-	-	-	-	-	-	-	-	-
TI06		External count clock input to 16-bit timer 06	√	√	√	√	-	-	-	-	-	-	-	-	-	-
TI07		External count clock input to 16-bit timer 07	√	√	√	√	√	√	√	-	-	-	-	-	-	-
TI10		External count clock input to 16-bit timer 10	√	√	√	-	-	-	-	-	-	-	-	-	-	-
TI11		External count clock input to 16-bit timer 11	√	√	√	-	-	-	-	-	-	-	-	-	-	-
TI12		External count clock input to 16-bit timer 12	√	√	√	-	-	-	-	-	-	-	-	-	-	-
TI13		External count clock input to 16-bit timer 13	√	√	√	-	-	-	-	-	-	-	-	-	-	-
TI14		External count clock input to 16-bit timer 14	√	-	-	-	-	-	-	-	-	-	-	-	-	-
TI15		External count clock input to 16-bit timer 15	√	-	-	-	-	-	-	-	-	-	-	-	-	-
TI16		External count clock input to 16-bit timer 16	√	-	-	-	-	-	-	-	-	-	-	-	-	-
TI17		External count clock input to 16-bit timer 17	√	-	-	-	-	-	-	-	-	-	-	-	-	-
TO00		Output	16-bit timer 00 output	√	√	√	√	√	√	√	√	√	√	√	√	√
TO01	16-bit timer 01 output		√	√	√	√	√	√	√	√	√	√	√	√	√	√
TO02	16-bit timer 02 output		√	√	√	√	√	√	√	√	√	√	√	√	√	√
TO03	16-bit timer 03 output		√	√	√	√	√	√	√	√	√	√	√	√	√	-
TO04	16-bit timer 04 output		√	√	√	√	(√)	(√)	(√)	(√)	(√)	(√)	(√)	(√)	-	-
TO05	16-bit timer 05 output		√	√	√	√	(√)	(√)	(√)	(√)	(√)	(√)	(√)	(√)	-	-
TO06	16-bit timer 06 output		√	√	√	√	(√)	(√)	(√)	(√)	(√)	(√)	(√)	(√)	-	-
TO07	16-bit timer 07 output		√	√	√	√	√	√	√	√	(√)	(√)	(√)	(√)	-	-

**Remark** Functions in parentheses in the above figure can be assigned via settings in the peripheral I/O redirection register (PIOR).



(5/6)

Function Name	I/O	Function	128-pin	100-pin	80-pin	64-pin	52-pin	48-pin	44-pin	40-pin	36-pin	32-pin	30-pin	25-pin	24-pin	20-pin
TO10	Output	16-bit timer 10 output	√	√	√	–	–	–	–	–	–	–	–	–	–	–
TO11		16-bit timer 11 output	√	√	√	–	–	–	–	–	–	–	–	–	–	–
TO12		16-bit timer 12 output	√	√	√	–	–	–	–	–	–	–	–	–	–	–
TO13		16-bit timer 13 output	√	√	√	–	–	–	–	–	–	–	–	–	–	–
TO14		16-bit timer 14 output	√	–	–	–	–	–	–	–	–	–	–	–	–	–
TO15		16-bit timer 15 output	√	–	–	–	–	–	–	–	–	–	–	–	–	–
TO16		16-bit timer 16 output	√	–	–	–	–	–	–	–	–	–	–	–	–	–
TO17		16-bit timer 17 output	√	–	–	–	–	–	–	–	–	–	–	–	–	–
TxD0	Output	Serial data output from UART0	√	√	√	√	√	√	√	√	√	√	√	√	√	√
TxD1		Serial data output from UART1	√	√	√	√	√	√	√	√	√	√	√	√	√	√
TxD2		Serial data output from UART2	√	√	√	√	√	√	√	√	√	√	√	–	–	–
TxD3		Serial data output from UART3	√	√	√	–	–	–	–	–	–	–	–	–	–	–
<R> X1	–	Resonator connection for main system clock	√	√	√	√	√	√	√	√	√	√	√	√	√	√
<R> X2	–		√	√	√	√	√	√	√	√	√	√	√	√	√	√
EXCLK	Input	External clock input for main system clock	√	√	√	√	√	√	√	√	√	√	√	√	√	√
EXCLKS	Input	External clock input for subsystem clock	√	√	√	√	√	√	√	√	–	–	–	–	–	–
<R> XT1	–	Resonator connection for subsystem clock	√	√	√	√	√	√	√	√	–	–	–	–	–	–
<R> XT2	–		√	√	√	√	√	√	√	√	–	–	–	–	–	–

(6/6)

Function Name	I/O	Function	128-pin	100-pin	80-pin	64-pin	52-pin	48-pin	44-pin	40-pin	36-pin	32-pin	30-pin	25-pin	24-pin	20-pin
V <sub>DD</sub>	–	<20-pin, 24-pin, 25-pin, 30-pin, 32-pin, 36-pin, 40-pin, 44-pin, 48-pin, 52-pin> Positive power supply for all pins <64-pin, 80-pin, 100-pin, 128-pin > Positive power supply for P20 to P27, P121 to P124, P137, P150 to P156 and other than ports	√	√	√	√	√	√	√	√	√	√	√	√	√	√
EV <sub>DD0</sub>	–	Positive power supply for ports (other than P20 to P27, P121 to P124, P137, P150 to P156)	√	√	√	√	–	–	–	–	–	–	–	–	–	–
EV <sub>DD1</sub>	–		√	√	–	–	–	–	–	–	–	–	–	–	–	–
AV <sub>REFP</sub>	Input	A/D converter reference potential (+ side) input	√	√	√	√	√	√	√	√	√	√	√	√	√	√
AV <sub>REFM</sub>	Input	A/D converter reference potential (– side) input	√	√	√	√	√	√	√	√	√	√	√	√	√	√
V <sub>SS</sub>	–	<20-pin, 24-pin, 25-pin, 30-pin, 32-pin, 36-pin, 40-pin, 44-pin, 48-pin, 52-pin > Ground potential for all pins <64-pin, 80-pin, 100-pin, 128-pin > Ground potential for P20 to P27, P121 to P124, P137, P150 to P156 and other than ports	√	√	√	√	√	√	√	√	√	√	√	√	√	√
EV <sub>SS0</sub>	–	Ground potential for ports (other than P20 to P27, P121 to P124, P137, P150 to P156)	√	√	√	√	–	–	–	–	–	–	–	–	–	–
EV <sub>SS1</sub>	–		√	√	–	–	–	–	–	–	–	–	–	–	–	–
TOOLRxD	Input	UART reception pin for the external device connection used during flash memory programming	√	√	√	√	√	√	√	√	√	√	√	√	√	√
TOOLTxD	Output	UART transmission pin for the external device connection used during flash memory programming	√	√	√	√	√	√	√	√	√	√	√	√	√	√
TOOL0	I/O	Data I/O for flash memory programmer/debugger	√	√	√	√	√	√	√	√	√	√	√	√	√	√

## 2.2 Description of Pin Functions

**Remark** The pins mounted depend on the product. See **1.3 Pin Configuration (Top View)** and **2.1 Pin Function List**.

### 2.2.1 P00 to P07 (port 0)

P00 to P07 function as an I/O port. These pins also function as timer I/O, A/D converter analog input, serial interface data I/O, and clock I/O.

Use of an on-chip pull-up resistor can be specified by pull-up resistor option register 0 (PU0).

Input to the P01, P03, and P04 pins can be specified through a normal input buffer or a TTL input buffer in 1-bit units, using port input mode register 0 (PIM0).

Output from the P00 and P02 to P04 pins can be specified as normal CMOS output or N-ch open-drain output ( $V_{DD}$  tolerance) in 1-bit units, using port output mode register 0 (POM0).

<R> When the following pins are used as input, specify them as either digital or analog in Port mode control register 0 (PMC0). This register can be specified in 1-bit unit.

- P00 and P01 pins of the 20, 24, 25, 30, and 32-pin products
- P02 and P03 pins of the 52, 64, 80, 100, and 128-pin products

The following operation modes can be specified in 1-bit units.

#### (1) Port mode

P00 to P07 function as an I/O port. P00 to P07 can be set to input or output port in 1-bit units using port mode register 0 (PM0).

#### (2) Control mode

P00 to P07 function as timer I/O, A/D converter analog input, serial interface data I/O, and clock I/O.

##### (a) ANI16, ANI17

These are the analog input pins (ANI16, ANI17) of A/D converter.

When using these pins as analog input pins, see **Figure 11-46. Analog Input Pin Connection**.

##### (b) SI10

This is a serial data input pin of serial interface CSI10.

##### (c) SO10

This is a serial data output pin of serial interface CSI10.

##### (d) $\overline{SCK10}$

This is a serial clock I/O pin of serial interface CSI10.

##### (e) TxD1

This is a serial data output pin of serial interface UART1.

##### (f) RxD1

This is a serial data input pin of serial interface UART1.

##### (g) SDA10

This is a serial data I/O pin of serial interface IIC10.

**(h) SCL10**

This is a serial clock output pin of serial interface IIC10.

**(i) TI00, TI05, TI06**

There are the pins for inputting an external count clock/capture trigger to 16-bit timers 00, 05, and 06.

**(j) TO00, TO05, TO06**

These are the timer output pins of 16-bit timers 00, 05, and 06.

**2.2.2 P10 to P17 (port 1)**

P10 to P17 function as an I/O port. These pins also function as serial interface data I/O, clock I/O, programming UART I/O, timer I/O, clock/buzzer output, and external interrupt request input.

Use of an on-chip pull-up resistor can be specified by pull-up resistor option register 1 (PU1).

Input to the P10, P11 and P13 to P17 pins can be specified through a normal input buffer or a TTL input buffer in 1-bit units, using port input mode register 1 (PIM1).

Output from the P10 to P15 and P17 pins can be specified as normal CMOS output or N-ch open-drain output ( $V_{DD}$  tolerance) in 1-bit units, using port output mode register 1 (POM1).

The following operation modes can be specified in 1-bit units.

**(1) Port mode**

P10 to P17 function as an I/O port. P10 to P17 can be set to input or output port in 1-bit units using port mode register 1 (PM1).

**(2) Control mode**

P10 to P17 function as serial interface data I/O, clock I/O, programming UART I/O, timer I/O, clock/buzzer output, and external interrupt request input.

**(a) INTP5**

This is an external interrupt request input pin for which the valid edge (rising edge, falling edge, or both rising and falling edges) can be specified.

**(b) TxD0, TxD2**

These are the serial data output pins of serial interface UART0 and UART2.

**(c) RxD0, RxD2**

These are the serial data input pins of serial interface UART0 and UART2.

**(d)  $\overline{\text{SCK00}}$ ,  $\overline{\text{SCK20}}$** 

These are the serial clock I/O pins of serial interface CSI00 and CSI20.

**(e) SI00, SI11, SI20**

These are the serial data input pins of serial interface CSI00, CSI11, and CSI20.

**(f) SO00, SO11, SO20**

These are the serial data output pins of serial interface CSI00, CSI11, and CSI20.

**(g) TI01, TI02**

These are the pins for inputting an external count clock/capture trigger to 16-bit timers 01 and 02.

**(h) TO01, TO02**

These are the timer output pins of 16-bit timers 01 and 02.

**(i) TOOLTxD**

This UART serial data output pin for an external device connection is used during flash memory programming.

**(j) TOOLRxD**

This UART serial data input pin for an external device connection is used during flash memory programming.

**(k) SDA00, SDA11, SDA20**

These are the serial data I/O pins of serial interface IIC00, IIC11 and IIC20.

**(l) SCL00, SCL20**

These are the serial clock output pins of serial interface IIC00 and IIC20.

**(m) PCLBUZ1**

This is the clock/buzzer output pin.

**2.2.3 P20 to P27 (port 2)**

P20 to P27 function as an I/O port. These pins also function as A/D converter analog input and reference voltage input.

<R> Setting digital or analog to each pin can be done in A/D port configuration register (ADPC).

The following operation modes can be specified in 1-bit units.

**(1) Port mode**

P20 to P27 function as an I/O port. P20 to P27 can be set to input or output port in 1-bit units using port mode register 2 (PM2).

**(2) Control mode**

P20 to P27 function as A/D converter analog input and reference voltage input.

**(a) ANI0 to ANI7**

These are the analog input pins (ANI0 to ANI7) of A/D converter.

When using these pins as analog input pins, see **Figure 11-46. Analog Input Pin Connection**.

**(b) AV<sub>REFP</sub>**

This is a pin that inputs the A/D converter reference potential (+ side).

**(c) AV<sub>REFM</sub>**

This is a pin that inputs the A/D converter reference potential (–side).

**2.2.4 P30 to P37 (port 3)**

P30 to P37 function as an I/O port. These pins also function as A/D converter analog input, external interrupt request input, real-time clock correction clock output, serial interface data I/O, clock I/O, clock/buzzer output, and timer I/O.

Use of an on-chip pull-up resistor can be specified by pull-up resistor option register 3 (PU3).

<R> When the P35 to P37 pins are used as input, specify them as either digital or analog in Port mode control register 3 (PMC3). This register can be specified in 1-bit unit.

The following operation modes can be specified in 1-bit units.

**(1) Port mode**

P30 to P37 function as an I/O port. P30 and P31 can be set to input or output port in 1-bit units using port mode register 3 (PM3).

**(2) Control mode**

P30 to P37 function as A/D converter analog input, external interrupt request input, real-time clock correction clock output, serial interface data I/O, clock I/O, clock/buzzer output, and timer I/O.

**(a) INTP3, INTP4**

These are the external interrupt request input pins for which the valid edge (rising edge, falling edge, or both rising and falling edges) can be specified.

**(b) RTC1HZ**

This is a real-time clock correction clock (1 Hz) output pin.

**(c)  $\overline{\text{SCK11}}$** 

This is a serial clock I/O pin of serial interface CSI11.

**(d) SCL11**

This is a serial clock output pin of serial interface IIC11.

**(e) TI03**

This is a pin for inputting an external count clock/capture trigger to 16-bit timer 03.

**(f) TO03**

This is a timer output pin from 16-bit timer 03.

**(g) PCLBUZ0**

This is a clock/buzzer output pin.

**(h) ANI21 to ANI23**

These are the analog input pins (ANI21 to ANI23) of A/D converter.

When using these pins as analog input pins, see **Figure 11-46. Analog Input Pin Connection**.

**2.2.5 P40 to P47 (port 4)**

P40 to P47 function as an I/O port. These pins also function as serial interface data I/O, clock I/O, external interrupt request input, data I/O for a flash memory programmer/debugger, and timer I/O.

Use of an on-chip pull-up resistor can be specified by pull-up resistor option register 4 (PU4).

Be sure to connect an external pull-up resistor to P40 when on-chip debugging is enabled (by using an option byte).

Input to the P43 and P44 pins can be specified through a normal input buffer or a TTL input buffer in 1-bit units, using port input mode register 4 (PIM4).

Output from the P43 to P45 pins can be specified as normal CMOS output or N-ch open-drain output ( $V_{DD}$  tolerance) in 1-bit units, using port output mode register 4 (POM4).

The following operation modes can be specified in 1-bit units.

**(1) Port mode**

P40 to P47 function as an I/O port. P40 to P47 can be set to input or output port in 1-bit units using port mode register 4 (PM4).

**(2) Control mode**

P40 to P47 function as serial interface data I/O, clock I/O, external interrupt request input, data I/O for a flash memory programmer/debugger, and timer I/O.

**(a) TI04, TI05, TI07**

These are the pins for inputting an external count clock/capture trigger to 16-bit timers 04, 05, and 07.

**(b) TO04, TO05, TO07**

These are the timer output pins from 16-bit timers 04, 05, and 07.

**(c) TOOL0**

This is a data I/O pin for a flash memory programmer/debugger.

Be sure to pull up this pin externally when on-chip debugging is enabled (pulling it down is prohibited).

**(d) INTP1, INTP2**

These are the external interrupt request input pins for which the valid edge (rising edge, falling edge, or both rising and falling edges) can be specified.

**(e)  $\overline{\text{SCK01}}$** 

This is a serial clock I/O pin of serial interface CSI01.

**(f) SCL01**

This is a serial clock output pin of serial interface IIC01.

**(g) SDA01**

This is a serial data I/O pin of serial interface IIC01.

**(h) SI01**

This is a serial data input pin of serial interface CSI01.

**(i) SO01**

This is a serial data output pin of serial interface CSI01.

**Caution** After reset release, the relationships between P40/TOOL0 and the operating mode are as follows.  
For details, see 25.5 Programming Method.

**Table 2-2. Relationships Between P40/TOOL0 and Operation Mode After Reset Release**

P40/TOOL0	Operating mode
V <sub>DD</sub>	Normal operation mode
0 V	Flash memory programming mode

### 2.2.6 P50 to P57 (port 5)

P50 to P57 function as an I/O port. These pins also function as external interrupt request input, serial interface data I/O, and clock I/O.

Use of an on-chip pull-up resistor can be specified by pull-up resistor option register 5 (PU5).

Input to the P53 to P55 pins can be specified through a normal input buffer or a TTL input buffer in 1-bit units, using port input mode register 5 (PIM5).

Output from the P50 and P52 to P55 pins can be specified as normal CMOS output or N-ch open-drain output ( $V_{DD}$  tolerance) in 1-bit units, using port output mode register 5 (POM5).

The following operation modes can be specified in 1-bit units.

#### (1) Port mode

P50 to P57 function as an I/O port. P50 to P57 can be set to input or output port in 1-bit units using port mode register 5 (PM5).

#### (2) Control mode

P50 to P57 function as external interrupt request input, serial interface data I/O, and clock I/O.

##### (a) INTP1, INTP2

These are the external interrupt request input pins for which the valid edge (rising edge, falling edge, or both rising and falling edges) can be specified.

##### (b) SI11, SI31

These are the serial data input pins of serial interface CSI11 and CSI31.

##### (c) SO11, SO31

These are the serial data output pins of serial interface CSI11 and CSI31.

##### (d) SDA11, SDA31

These are the serial data I/O pins of serial interface IIC11 and IIC31.

##### (e) $\overline{\text{SCK31}}$

This is a serial clock I/O pin of serial interface CSI31.

##### (f) SCL31

This is a serial clock output pin of serial interface IIC31.

### 2.2.7 P60 to P67 (port 6)

P60 to P67 function as an I/O port. These pins also function as timer I/O, serial interface data I/O, and clock I/O.

P64 to P67 use of an on-chip pull-up resistor can be specified by pull-up resistor option register 6 (PU6).

The following operation modes can be specified in 1-bit units.

#### (1) Port mode

P60 to P67 function as an I/O port. P60 to P67 can be set to input port or output port in 1-bit units using port mode register 6 (PM6).

Output of P60 to P63 is N-ch open-drain output (6 V tolerance).

#### (2) Control mode

P60 to P67 function as timer I/O, serial interface data I/O, and clock I/O.



**(a) SCLA0, SCLA1**

These are the serial clock I/O pins of serial interface IICA.

**(b) SDAA0, SDAA1**

These are the serial data I/O pins of serial interface IICA.

**(c) TI10, TI11, TI12, TI13**

These are the pins for inputting an external count clock/capture trigger to 16-bit timers 10, 11, 12, and 13.

**(d) TO10, TO11, TO12, TO13**

These are the timer output pins of 16-bit timers 10, 11, 12, and 13.

**2.2.8 P70 to P77 (port 7)**

P70 to P77 function as an I/O port. These pins also function as key interrupt input, serial interface data I/O, clock I/O, and external interrupt request input.

Use of an on-chip pull-up resistor can be specified by pull-up resistor option register 7 (PU7).

Output from the P71 and P74 pins can be specified as normal CMOS output or N-ch open-drain output ( $V_{DD}$  tolerance) in 1-bit units, using port output mode register 7 (POM7).

The following operation modes can be specified in 1-bit units.

**(1) Port mode**

P70 to P77 function as an I/O port. P70 to P77 can be set to input or output port in 1-bit units using port mode register 7 (PM7).

**(2) Control mode**

P70 to P77 function as key interrupt input, serial interface data I/O, clock I/O, and external interrupt request input.

**(a) INTP8 to INTP11**

These are the external interrupt request input pins for which the valid edge (rising edge, falling edge, or both rising and falling edges) can be specified.

**(b) KR0 to KR7**

These are the key interrupt input pins.

**(c) SI01, SI21**

These are the serial data input pins of serial interface CSI01 and CSI21.

**(d) SO01, SO21**

These are the serial data output pins of serial interface CSI01 and CSI21.

**(e)  $\overline{\text{SCK01}}$ ,  $\overline{\text{SCK21}}$** 

These are the serial clock I/O pins of serial interface CSI01 and CSI21.

**(f) SCL01, SCL21**

These are the serial clock output pins of serial interface IIC01 and IIC21.

**(g) SDA01, SDA21**

These are the serial data I/O pins of serial interface IIC01 and IIC21.

**2.2.9 P80 to P87 (port 8)**

P80 to P87 function as an I/O port.

Use of an on-chip pull-up resistor can be specified by pull-up resistor option register 8 (PU8).

Input to the P80 and P81 pins can be specified through a normal input buffer or a TTL input buffer in 1-bit units, using port input mode register 8 (PIM8).

Output from the P80 to P82 pins can be specified as normal CMOS output or N-ch open-drain output ( $V_{DD}$  tolerance) in 1-bit units, using port output mode register 8 (POM8).

**(1) Port mode**

P80 to P87 function as an I/O port. P80 to P87 can be set to input or output port in 1-bit units using port mode register 8 (PM8).

**2.2.10 P90 to P97 (port 9)**

P90 to P97 function as an I/O port. These pins also function as serial interface data I/O and clock I/O.

Use of an on-chip pull-up resistor can be specified by pull-up resistor option register 9 (PU9).

Output from the P96 pin can be specified as normal CMOS output or N-ch open-drain output ( $V_{DD}$  tolerance) in 1-bit units, using port output mode register 9 (POM9).

**(1) Port mode**

P90 to P97 function as an I/O port. P90 to P97 can be set to input or output port in 1-bit units using port mode register 9 (PM9).

**(2) Control mode**

P90 to P97 function as serial interface data I/O and clock I/O.

**(a) SI11**

This is a serial data input pin of serial interface CSI11.

**(b) SO11**

This is a serial data output pin of serial interface CSI11.

**(c)  $\overline{SCK11}$** 

This is a serial clock I/O pin of serial interface CSI11.

**(d) SCL11**

This is a serial clock output pin of serial interface IIC11.

**(e) SDA11**

This is a serial data I/O pin of serial interface IIC11.

**2.2.11 P100 to P106 (port 10)**

P100 to P106 function as an I/O port. These pins also function as A/D converter analog input and timer I/O.

<R> Use of an on-chip pull-up resistor can be specified by pull-up resistor option register 10 (PU10).

When the P100 pin is used as input, specify them as either digital or analog in Port mode control register 10 (PMC10). This register can be specified in 1-bit unit.

The following operation modes can be specified in 1-bit units.

**(1) Port mode**

P100 to P106 function as an I/O port. P100 to P106 can be set to input or output port in 1-bit units using port mode register 10 (PM10).

**(2) Control mode**

P100 to P106 function as serial interface data I/O and clock I/O. These pins also function as A/D converter analog input and timer I/O.

**(a) ANI20**

This is an analog input pin (ANI20) of A/D converter.

When using this pin as analog input pin, see **Figure 11-46. Analog Input Pin Connection.**

**(b) TI06, TI14 to TI17**

These are the pins for inputting an external count clock/capture trigger to 16-bit timers 06, 14, 15, 16, and 17.

**(c) TO06, TO14 to TO17**

These are the timer output pins of 16-bit timers 06, 14, 15, 16, and 17.

**2.2.12 P110 to P117 (port 11)**

P110 to P117 function as an I/O port. These pins also function as A/D converter analog input.

<R> Use of an on-chip pull-up resistor can be specified by pull-up resistor option register 11 (PU11).

When the P115 to P117 pins are used as input, specify them as either digital or analog in Port mode control register 11 (PMC11). This register can be specified in 1-bit unit.

The following operation modes can be specified in 1-bit units.

**(1) Port mode**

P110 to P117 function as an I/O port. P110 to P117 can be set to input or output port in 1-bit units using port mode register 11 (PM11).

**(2) Control mode**

P110 to P117 function as A/D converter analog input.

**(a) ANI24 to ANI26**

These are the analog input pins (ANI24 to ANI26) of A/D converter.

When using this pin as analog input pin, see **Figure 11-46. Analog Input Pin Connection.**

**2.2.13 P120 to P127 (port 12)**

P120 and P125 to P127 function as an I/O port. P121 to P124 functions as 4-bit input port. These pins also function as A/D converter analog input, connecting resonator for main system clock, connecting resonator for subsystem clock, external clock input for main system clock, and external clock input for subsystem clock.

<R> P120, P125 to P127 use of an on-chip pull-up resistor can be specified by pull-up resistor option register 12 (PU12).

When the P120 pin is used as input, specify them as either digital or analog in Port mode control register 12 (PMC12). This register can be specified in 1-bit unit.

The following operation modes can be specified in 1-bit units.

**(1) Port mode**

P120 and P125 to P127 function as a 1-bit I/O port. P120 can be set to input or output port using port mode register 12 (PM12).

P121 to P124 functions as a 4-bit input port.

**(2) Control mode**

P120 to P124 function as A/D converter analog input, connecting resonator for main system clock, connecting resonator for subsystem clock, external clock input for main system clock, and external clock input for subsystem clock.

**(a) ANI19**

This is an analog input pin of A/D converter.

When using this pin as analog input pin, see **Figure 11-46. Analog Input Pin Connection.**

**(b) X1, X2**

These are the pins for connecting a resonator for main system clock.

**(c) EXCLK**

This is an external clock input pin for main system clock.

**(d) XT1, XT2**

These are the pins for connecting a resonator for subsystem clock.

**(e) EXCLKS**

This is an external clock input pin for subsystem clock.

**2.2.14 P130, P137 (port 13)**

P130 functions as a 1-bit output-only port. P137 functions as a 1-bit input-only port. P137 pin also functions as external interrupt request input.

**(1) Port mode**

P130 functions as a 1-bit output-only port.

P137 functions as a 1-bit input-only port.

**(2) Control mode**

P137 functions as external interrupt request input.

**(a) INTPO**

This is an external interrupt request input pin for which the valid edge (rising edge, falling edge, or both rising and falling edges) can be specified.

**2.2.15 P140 to P147 (port 14)**

P140 to P147 function as an I/O port. These pins also function as clock/buzzer output, external interrupt request input, A/D converter analog input, serial interface data I/O, clock I/O, and timer I/O.

Use of an on-chip pull-up resistor can be specified by pull-up resistor option register 14 (PU14).

Input to the P142 and P143 pins can be specified through a normal input buffer or a TTL input buffer in 1-bit units, using port input mode register 14 (PIM14).

Output from the P142 to P144 pins can be specified as normal CMOS output or N-ch open-drain output ( $V_{DD}$  tolerance) in 1-bit units, using port output mode register 14 (POM14).

<R> When the P147 pin is used as input, specify them as either digital or analog in Port mode control register 14 (PMC14). This register can be specified in 1-bit unit.

The following operation modes can be specified in 1-bit units.

**(1) Port mode**

P140 to P147 function as an I/O port. P140 to P147 can be set to input or output port in 1-bit units using port mode register 14 (PM14).

**(2) Control mode**

P140 to P147 function as clock/buzzer output, external interrupt request input, and A/D converter analog input, serial interface data I/O, clock I/O, and timer I/O.

**(a) ANI18**

This is an analog input pin of A/D converter.

When using this pin as analog input pin, see **Figure 11-46. Analog Input Pin Connection.**

**(b) INTP6, INTP7**

These are the external interrupt request input pins for which the valid edge (rising edge, falling edge, or both rising and falling edges) can be specified.

**(c) PCLBUZ0, PCLBUZ1**

These are the clock/buzzer output pins.

**(d) RxD3**

This is a serial data input pin of serial interface UART3.

**(e)  $\overline{\text{SCK30}}$**

This is a serial clock I/O pin of serial interface CSI30.

**(f) SCL30**

This is a serial clock Output pin of serial interface IIC30.

**(g) SDA30**

This is a serial data I/O pin of serial interface IIC30.

**(h) SI30**

This is a serial data input pin of serial interface CSI30.

**(i) SO30**

This is a serial data output pin of serial interface CSI30.

**(j) TI07**

This is a pin for inputting an external count clock/capture trigger to 16-bit timer 07.

**(k) TO07**

This is a timer output pin of 16-bit timer 07.

**(l) TxD3**

This is a serial data output pin of serial interface UART3.

### 2.2.16 P150 to P156 (port 15)

P150 to P156 function as an I/O port. These pins also function as A/D converter analog input.

The following operation modes can be specified in 1-bit units.

#### (1) Port mode

P150 to P156 function as an I/O port. P150 to P156 can be set to input or output port in 1-bit units using port mode register 15 (PM15).

#### (2) Control mode

P150 to P156 function as A/D converter analog input.

##### (a) ANI8 to ANI14

These are the analog input pins (ANI8 to ANI14) of A/D converter.

When using these pins as analog input pin, see **Figure 11-46. Analog Input Pin Connection**.

### 2.2.17 V<sub>DD</sub>, EV<sub>DD0</sub>, EV<sub>DD1</sub>, V<sub>SS</sub>, EV<sub>SS0</sub>, EV<sub>SS1</sub>

#### (1) V<sub>DD</sub>, EV<sub>DD0</sub>, EV<sub>DD1</sub>

When using the 20- to 52-pin products, V<sub>DD</sub> is the positive power supply pin. When using the 64-, 80-, 100-, and 128-pin products, V<sub>DD</sub> is the positive power supply pin for P20 to P27, P121 to P124, P137, P150 to P156 and pins other than ports.

EV<sub>DD0</sub> and EV<sub>DD1</sub> are the positive power supply pin for ports other than P20 to P27, P121 to P124, P137, and P150 to P156.

#### (2) V<sub>SS</sub>, EV<sub>SS0</sub>, EV<sub>SS1</sub>

When using the 20- to 52-pin products, V<sub>SS</sub> is the ground potential pin. When using the 64-, 80-, 100-, and 128-pin products, V<sub>SS</sub> is the ground potential pin for P20 to P27, P121 to P124, P137, P150 to P156 and pins other than ports.

EV<sub>SS0</sub> and EV<sub>SS1</sub> is the ground potential pin for ports other than P20 to P27, P121 to P124, P137, and P150 to P156.

<R> **Remark Use bypass capacitors (about 0.1  $\mu$ F) as noise and latch up countermeasures with relatively thick wires at the shortest distance to V<sub>DD</sub> to V<sub>SS</sub>, EV<sub>DD0</sub> to EV<sub>SS0</sub> and EV<sub>DD1</sub> to EV<sub>SS1</sub> lines.**

### 2.2.18 RESET

This is the active-low system reset input pin.

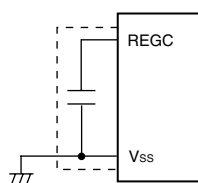
When the external reset pin is not used, connect this pin directly or via a resistor to V<sub>DD</sub>.

When the external reset pin is used, design the circuit based on V<sub>DD</sub>.

### 2.2.19 REGC

<R> This is the pin for connecting regulator output stabilization capacitance for internal operation. Connect this pin to V<sub>SS</sub> via a capacitor (0.47 to 1  $\mu$ F).

Also, use a capacitor with good characteristics, since it is used to stabilize internal voltage.



**Caution Keep the wiring length as short as possible for the broken-line part in the above figure.**

### 2.3 Pin I/O Circuits and Recommended Connection of Unused Pins

Table 2-3 shows the types of pin I/O circuits and the recommended connections of unused pins.

<R>

**Table 2-3. Connection of Unused Pins (128-pin products) (1/4)**

Pin Name	I/O Circuit Type	I/O	Recommended Connection of Unused Pins	
P00/TI00	8-R	I/O	Input: Independently connect to EV <sub>DD0</sub> , EV <sub>DD1</sub> or EV <sub>SS0</sub> , EV <sub>SS1</sub> via a resistor. Output: Leave open.	
P01/TO00	5-AN			
P02/ANI17/SO10/TxD1	11-U			
P03/ANI16/SI10/RxD1/ SDA10	11-V			
P04/SCK10/SCL10	5-AN			
P05	8-R			
P06				
P07				
P10/SCK00/SCL00/(TI07)/(T O07)	5-AN			
P11/SI00/RxD0/ TOOLRxD/SDA00/(TI06)/ (TO06)				
P12/SO00/TxD0/ TOOLTxD/(INTP5)/(TI05)/ (TO05)	8-R			
P13/TxD2/SO20/(SDAA0)/(TI 04)/(TO04)	5-AN			
P14/RxD2/SI20/SDA20/ (SCLA0)/(TI03)/(TO03)				
P15/SCK20/SCL20/(TI02)/(T O02)				
P16/TI01/TO01/INTP5/ (SI00)/(RxD0)				
P17/TI02/TO02/(SO00)/ (TxD0)				
P20/ANI0/AV <sub>REFP</sub>	11-T			Input: Independently connect to V <sub>DD</sub> or V <sub>SS</sub> via a resistor. Output: Leave open.
P21/ANI1/AV <sub>REFM</sub>				
P22/ANI2	11-G			
P23/ANI3				
P24/ANI4				
P25/ANI5				
P26/ANI6				
P27/ANI7				

**Remarks 1.** With products not provided with an EV<sub>DD0</sub>, EV<sub>DD1</sub>, EV<sub>SS0</sub>, or EV<sub>SS1</sub> pin, replace EV<sub>DD0</sub> and EV<sub>DD1</sub> with V<sub>DD</sub>, or replace EV<sub>SS0</sub> and EV<sub>SS1</sub> with V<sub>SS</sub>.

**2.** Functions in parentheses in the above figure can be assigned via settings in the peripheral I/O redirection register (PIOR).

&lt;R&gt;

Table 2-3. Connection of Unused Pins (128-pin products) (2/4)

Pin Name	I/O Circuit Type	I/O	Recommended Connection of Unused Pins
P30/INTP3/RTC1HZ	8-R	I/O	Input: Independently connect to EV <sub>DD0</sub> , EV <sub>DD1</sub> or EV <sub>SS0</sub> , EV <sub>SS1</sub> via a resistor. Output: Leave open.
P31/TI03/TO03/INTP4/ (PCLBUZ0)			
P32			
P33			
P34			
P35/ANI23	11-U		
P36/ANI22			
P37/ANI21			
P40/TOOL0	8-R		Input: Independently connect to EV <sub>DD0</sub> , EV <sub>DD1</sub> or leave open. Output: Leave open.
P41			Input: Independently connect to EV <sub>DD0</sub> , EV <sub>DD1</sub> or EV <sub>SS0</sub> , EV <sub>SS1</sub> via a resistor. Output: Leave open.
P42/TI04/TO04			
P43/SCK01/SCL01	5-AN		
P44/SI01/SDA01			
P45/SO01	8-R		
P46/INTP1/TI05/TO05			
P47/INTP2			
P50			
P51			
P52/SO31			
P53/SI31/SDA31			
P54/SCK31/SCL31			
P55/(PCLBUZ1)/(SCK00)			
P56/(INTP1)	8-R		
P57/(INTP3)			
P60/SCLA0	13-R		
P61/SDAA0			
P62/SCLA1			
P63/SDAA1			
P64/TI10/TO10	8-R		
P65/TI11/TO11			
P66/TI12/TO12			
P67/TI13/TO13			

- Remarks 1.** With products not provided with an EV<sub>DD0</sub>, EV<sub>DD1</sub>, EV<sub>SS0</sub>, or EV<sub>SS1</sub> pin, replace EV<sub>DD0</sub> and EV<sub>DD1</sub> with V<sub>DD</sub>, or replace EV<sub>SS0</sub> and EV<sub>SS1</sub> with V<sub>SS</sub>.
- 2.** Functions in parentheses in the above figure can be assigned via settings in the peripheral I/O redirection register (PIOR).
- 3.** For 64-pin products, I/O circuit type for P43, P53 and P54 pins is 8-R.



&lt;R&gt;

Table 2-3. Connection of Unused Pins (128-pin products) (3/4)

Pin Name	I/O Circuit Type	I/O	Recommended Connection of Unused Pins
P70/KR0/SCK21/SCL21	8-R	I/O	Input: Independently connect to EV <sub>DD0</sub> , EV <sub>DD1</sub> or EV <sub>SS0</sub> , EV <sub>SS1</sub> via a resistor. Output: Leave open.
P71/KR1/SI21/SDA21			
P72/KR2/SO21			
P73/KR3			
P74/KR4/INTP8			
P75/KR5/INTP9			
P76/KR6/INTP10/(RxD2)			
P77/KR7/INTP11/(TxD2)			
P80/(SCK10)/(SCL10)	5-AN		
P81/(SI10)/(RxD1)/(SDA10)			
P82/(SO10)/(TxD1)	8-R		
P83			
P84/(INTP6)			
P85/(INTP7)			
P86/(INTP8)			
P87/(INTP9)			
P90	8-R		
P91			
P92			
P93			
P94			
P95/SCK11/SCL11			
P96/SI11/SDA11			
P97/SO11			
P100/ANI20	11-U		
P101	8-R		
P102/TI06/TO06			
P103/TI14/TO14			
P104/TI15/TO15			
P105/TI16/TO16			
P106/TI17/TO17			
P110/(INTP10)			
P111/(INTP11)			
P112			
P113			
P114			

- Remarks 1.** With products not provided with an EV<sub>DD0</sub>, EV<sub>DD1</sub>, EV<sub>SS0</sub>, or EV<sub>SS1</sub> pin, replace EV<sub>DD0</sub> and EV<sub>DD1</sub> with V<sub>DD</sub>, or replace EV<sub>SS0</sub> and EV<sub>SS1</sub> with V<sub>SS</sub>.
- 2.** Functions in parentheses in the above figure can be assigned via settings in the peripheral I/O redirection register (PIOR).

&lt;R&gt;

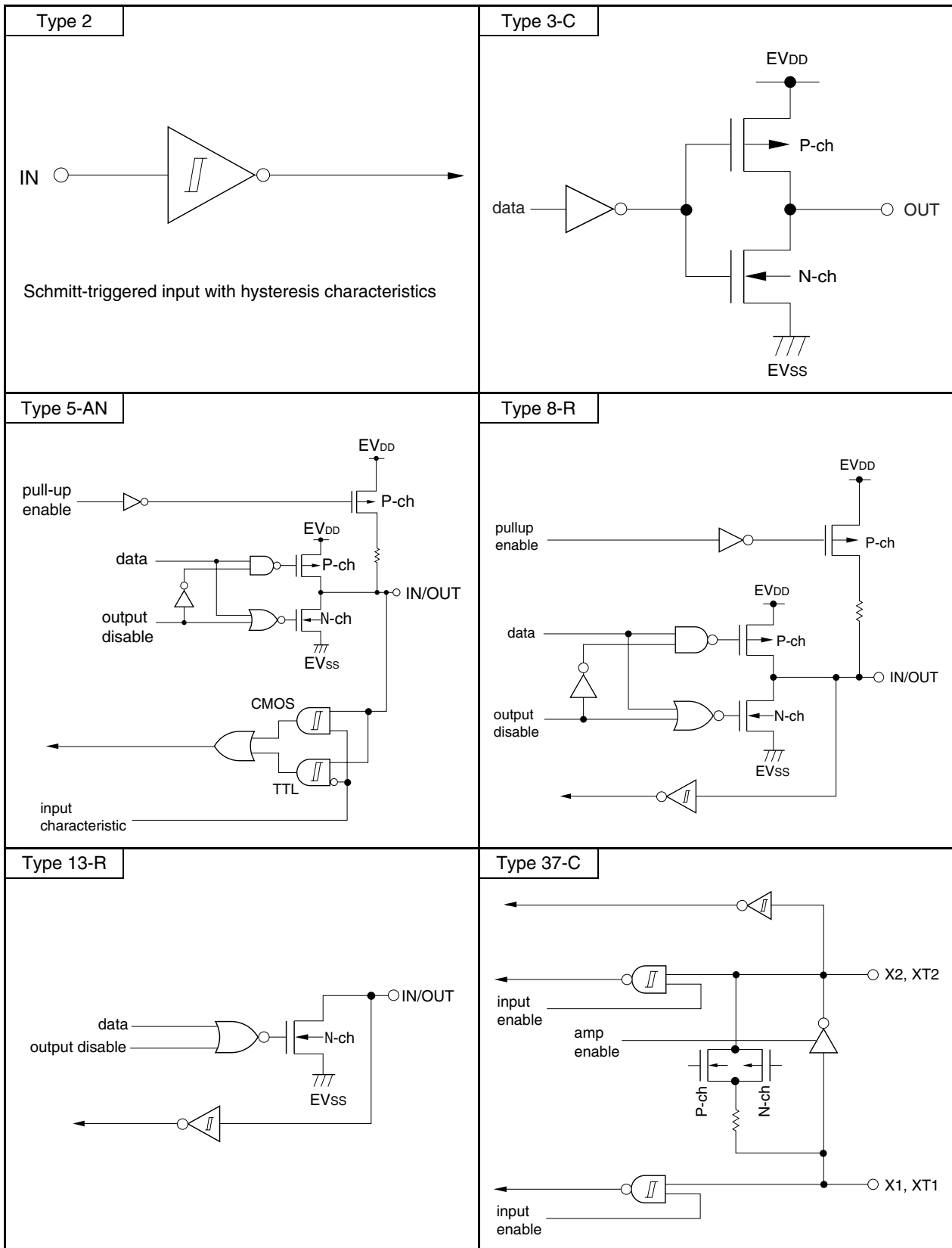
**Table 2-3. Connection of Unused Pins (128-pin products) (4/4)**

Pin Name	I/O Circuit Type	I/O	Recommended Connection of Unused Pins
P115/ANI26	11-U	I/O	Input: Independently connect to EV <sub>DD0</sub> , EV <sub>DD1</sub> or EV <sub>SS0</sub> , EV <sub>SS1</sub> via a resistor. Output: Leave open.
P116/ANI25			
P117/ANI24			
P120/ANI19			
P121/X1	37-C	Input	Independently connect to V <sub>DD</sub> or V <sub>SS</sub> via a resistor.
P122/X2/EXCLK			
P123/XT1			
P124/XT2/EXCLKS			
P125	8-R	I/O	Input: Independently connect to EV <sub>DD0</sub> , EV <sub>DD1</sub> or EV <sub>SS0</sub> , EV <sub>SS1</sub> via a resistor. Output: Leave open.
P126			
P127			
P130	3-C	Output	Leave open.
P137/INTP0	2	Input	Independently connect to V <sub>DD</sub> or V <sub>SS</sub> via a resistor.
P140/PCLBUZ0/INTP6	8-R	I/O	Input: Independently connect to EV <sub>DD0</sub> , EV <sub>DD1</sub> or EV <sub>SS0</sub> , EV <sub>SS1</sub> via a resistor. Output: Leave open.
P141/PCLBUZ1/INTP7			
P142/SCK30/SCL30	5-AN		
P143/SI30/RxD3/SDA30			
P144/SO30/TxD3	8-R		
P145/TI07/TO07			
P146/(INTP4)			
P147/ANI18	11-U		
P150/ANI8	11-G		Input: Independently connect to V <sub>DD</sub> or V <sub>SS</sub> via a resistor. Output: Leave open.
P151/ANI9			
P152/ANI10			
P153/ANI11			
P154/ANI12			
P155/ANI13			
P156/ANI14			
RESET	2	Input	Connect directly or via a resistor to V <sub>DD</sub> .
REGC	–	–	Connect to V <sub>SS</sub> via capacitor (0.47 to 1 μF).

- Remarks 1.** With products not provided with an EV<sub>DD0</sub>, EV<sub>DD1</sub>, EV<sub>SS0</sub>, or EV<sub>SS1</sub> pin, replace EV<sub>DD0</sub> and EV<sub>DD1</sub> with V<sub>DD</sub>, or replace EV<sub>SS0</sub> and EV<sub>SS1</sub> with V<sub>SS</sub>.
- 2.** Functions in parentheses in the above figure can be assigned via settings in the peripheral I/O redirection register (PIOR).

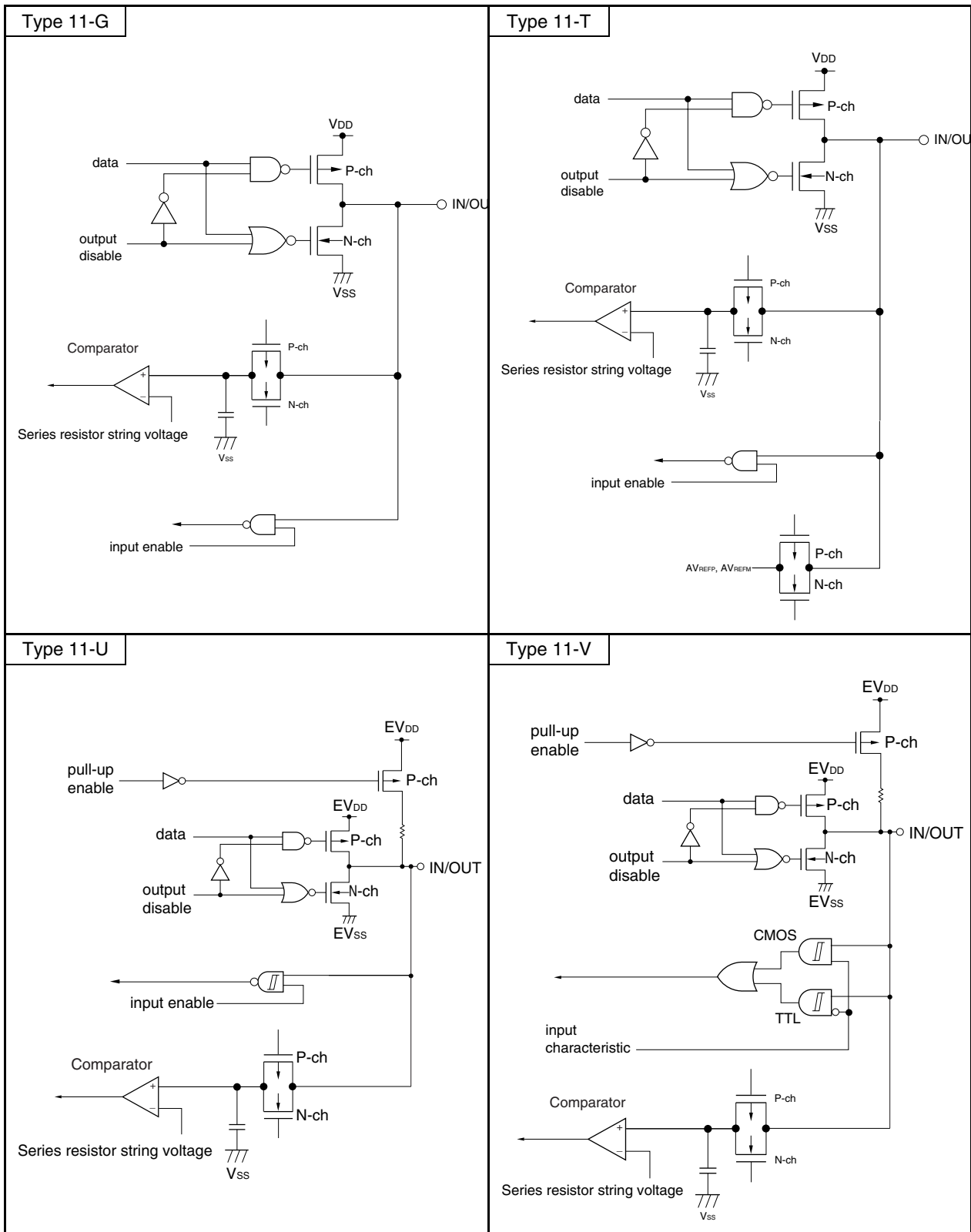
<R>

Figure 2-1. Pin I/O Circuit List (1/2)



<R>

Figure 2-1. Pin I/O Circuit List (2/2)



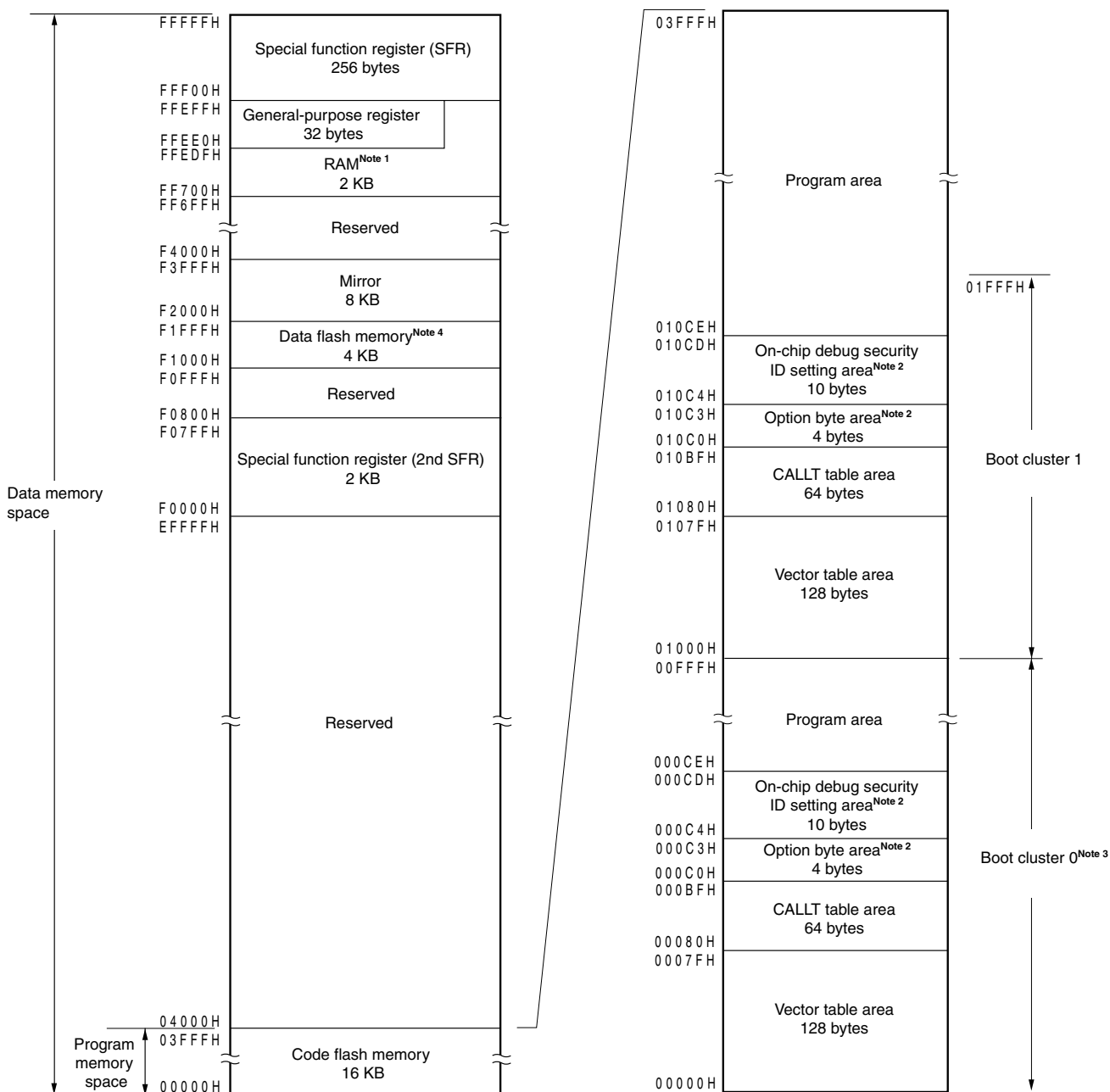
## CHAPTER 3 CPU ARCHITECTURE

### 3.1 Memory Space

Products in the RL78/G13 can access a 1 MB memory space. Figures 3-1 to 3-10 show the memory maps.

<R>

Figure 3-1. Memory Map (R5F100xA, R5F101xA(x = 6 to 8, A to C, E to G))

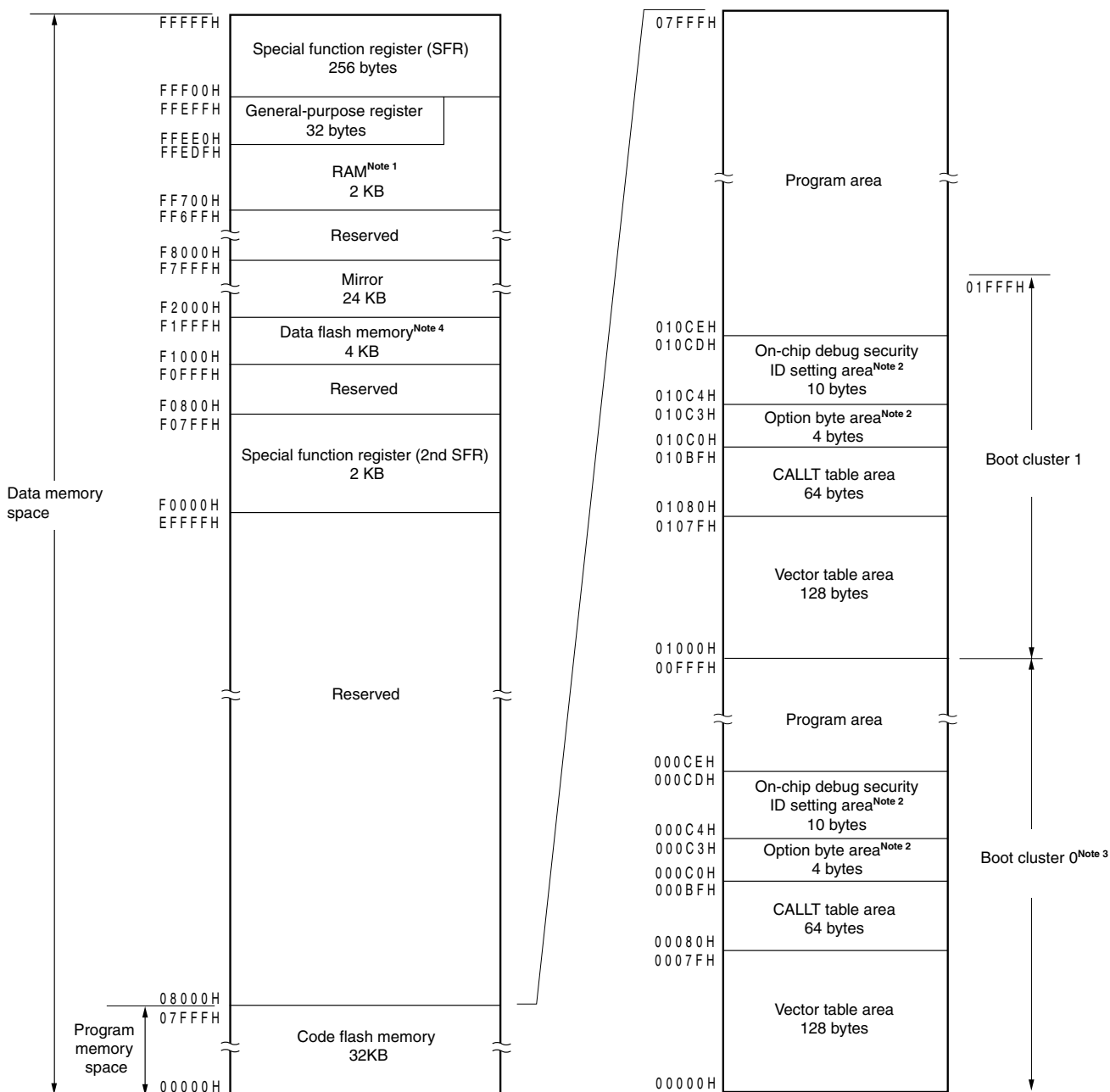


- Notes**
- Instructions can be executed from the RAM area excluding the general-purpose register area.
  - When boot swap is not used: Set the option bytes to 000C0H to 000C3H, and the on-chip debug security IDs to 000C4H to 000CDH.  
When boot swap is used: Set the option bytes to 000C0H to 000C3H and 010C0H to 010C3H, and the on-chip debug security IDs to 000C4H to 000CDH and 010C4H to 010CDH.
  - Writing boot cluster 0 can be prohibited depending on the setting of security (see 25.6 Security Setting).
  - R5F100xA only.

**Caution** When executing instructions from the RAM area while RAM parity error resets are enabled (RPERDIS = 1), be sure to initialize the used RAM area + 10 bytes.

<R>

Figure 3-2. Memory Map (R5F100xC, R5F101xC(x = 6 to 8, A to C, E to G, J, L))

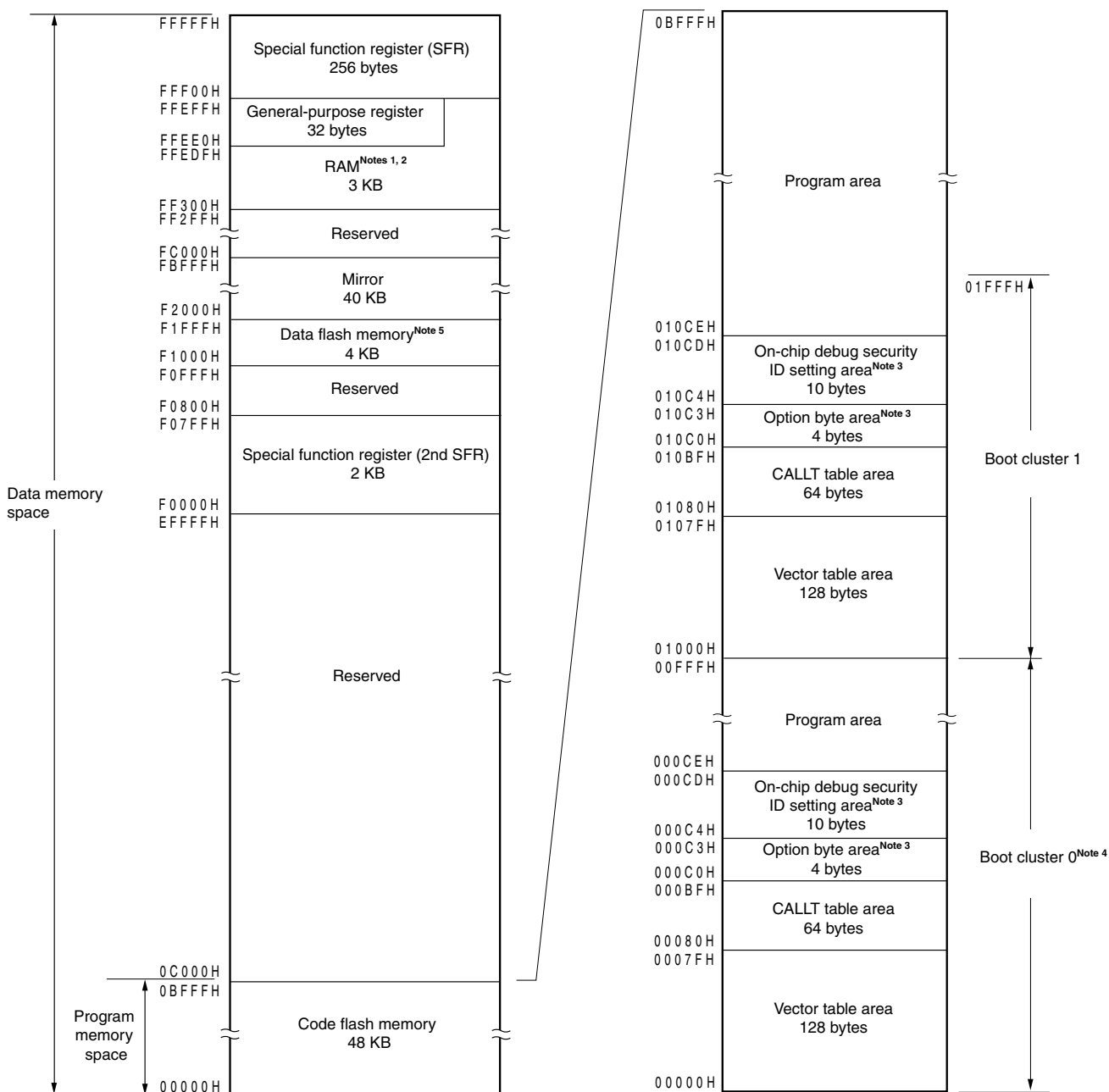


- Notes**
- Instructions can be executed from the RAM area excluding the general-purpose register area.
  - When boot swap is not used: Set the option bytes to 000C0H to 000C3H, and the on-chip debug security IDs to 000C4H to 000CDH.  
When boot swap is used: Set the option bytes to 000C0H to 000C3H and 010C0H to 010C3H, and the on-chip debug security IDs to 000C4H to 000CDH and 010C4H to 010CDH.
  - Writing boot cluster 0 can be prohibited depending on the setting of security (see 25.6 Security Setting).
  - R5F100xC only.

**Caution** When executing instructions from the RAM area while RAM parity error resets are enabled (RPERDIS = 1), be sure to initialize the used RAM area + 10 bytes.

<R>

**Figure 3-3. Memory Map (R5F100xD, R5F101xD(x = 6 to 8, A to C, E to G, J, L))**

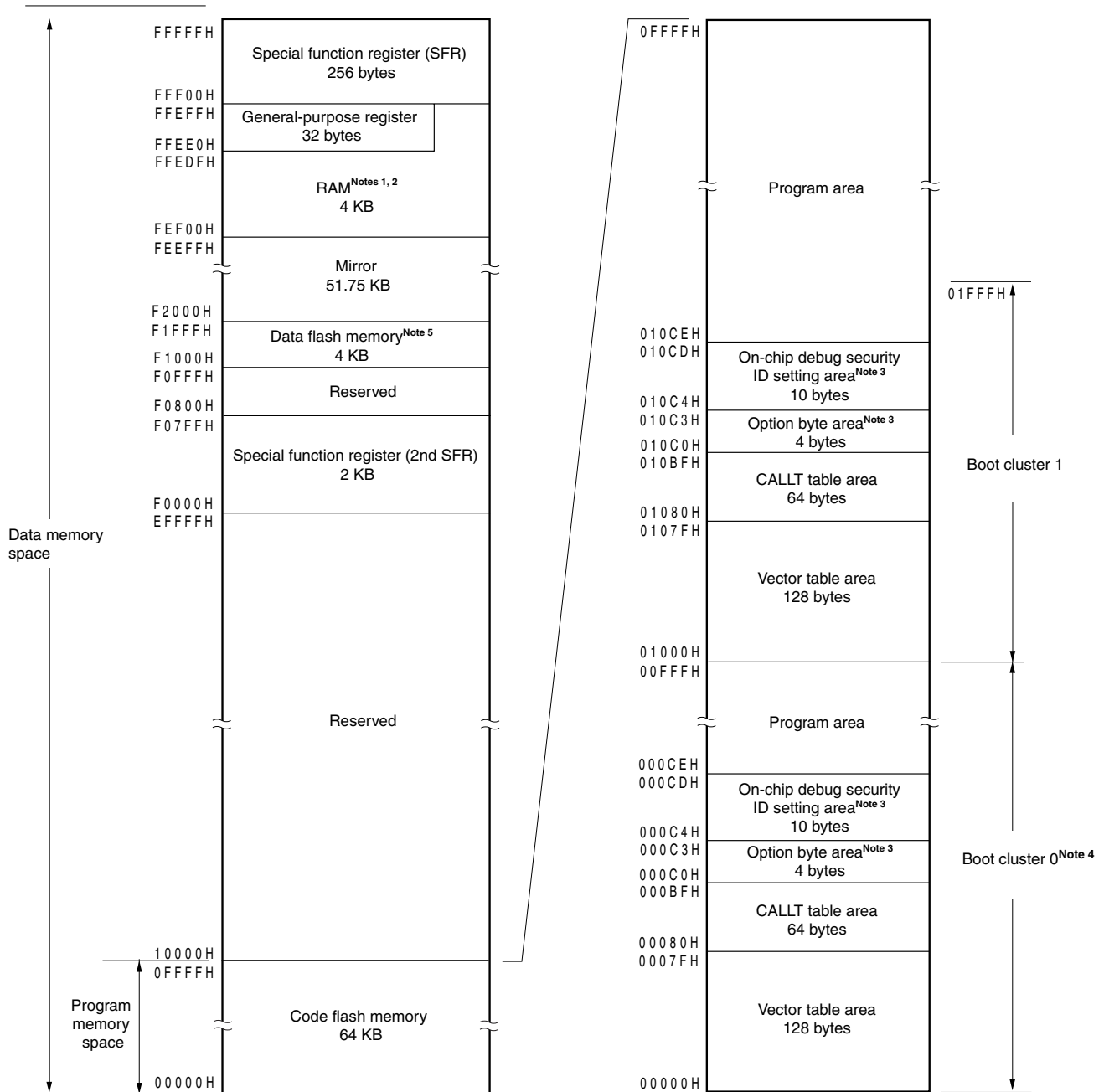


- <R> **Notes**
- Use of the area FF300H to FF309H is prohibited when using the self-programming function and data flash function, because this area is used for self-programming library.
  - Instructions can be executed from the RAM area excluding the general-purpose register area.
  - When boot swap is not used: Set the option bytes to 000C0H to 000C3H, and the on-chip debug security IDs to 000C4H to 000CDH.  
When boot swap is used: Set the option bytes to 000C0H to 000C3H and 010C0H to 010C3H, and the on-chip debug security IDs to 000C4H to 000CDH and 010C4H to 010CDH.
  - Writing boot cluster 0 can be prohibited depending on the setting of security (see 25.6 Security Setting).
  - R5F100xD only.

**Caution** When executing instructions from the RAM area while RAM parity error resets are enabled (RPERDIS = 1), be sure to initialize the used RAM area + 10 bytes.



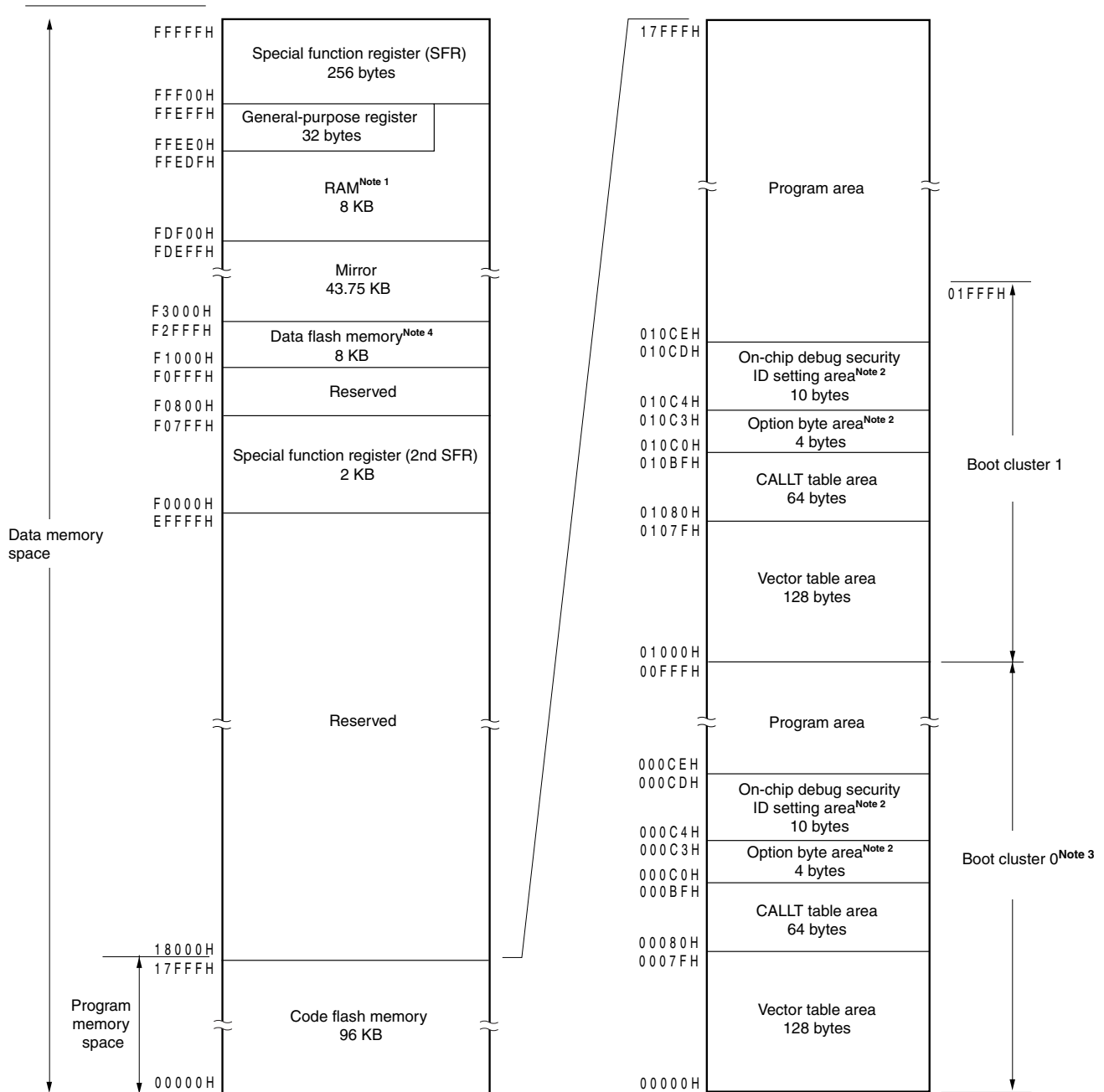
Figure 3-4. Memory Map (R5F100xE, R5F101xE(x = 6 to 8, A to C, E to G, J, L))



- <R> **Notes**
- Use of the area FEF00H to FF309H is prohibited when using the self-programming function and data flash function, because this area is used for self-programming library.
  - Instructions can be executed from the RAM area excluding the general-purpose register area.
  - When boot swap is not used: Set the option bytes to 000C0H to 000C3H, and the on-chip debug security IDs to 000C4H to 000CDH.  
When boot swap is used: Set the option bytes to 000C0H to 000C3H and 010C0H to 010C3H, and the on-chip debug security IDs to 000C4H to 000CDH and 010C4H to 010CDH.
  - Writing boot cluster 0 can be prohibited depending on the setting of security (see **25.6 Security Setting**).
  - R5F100xE only.

**Caution** When executing instructions from the RAM area while RAM parity error resets are enabled (RPERDIS = 1), be sure to initialize the used RAM area + 10 bytes.

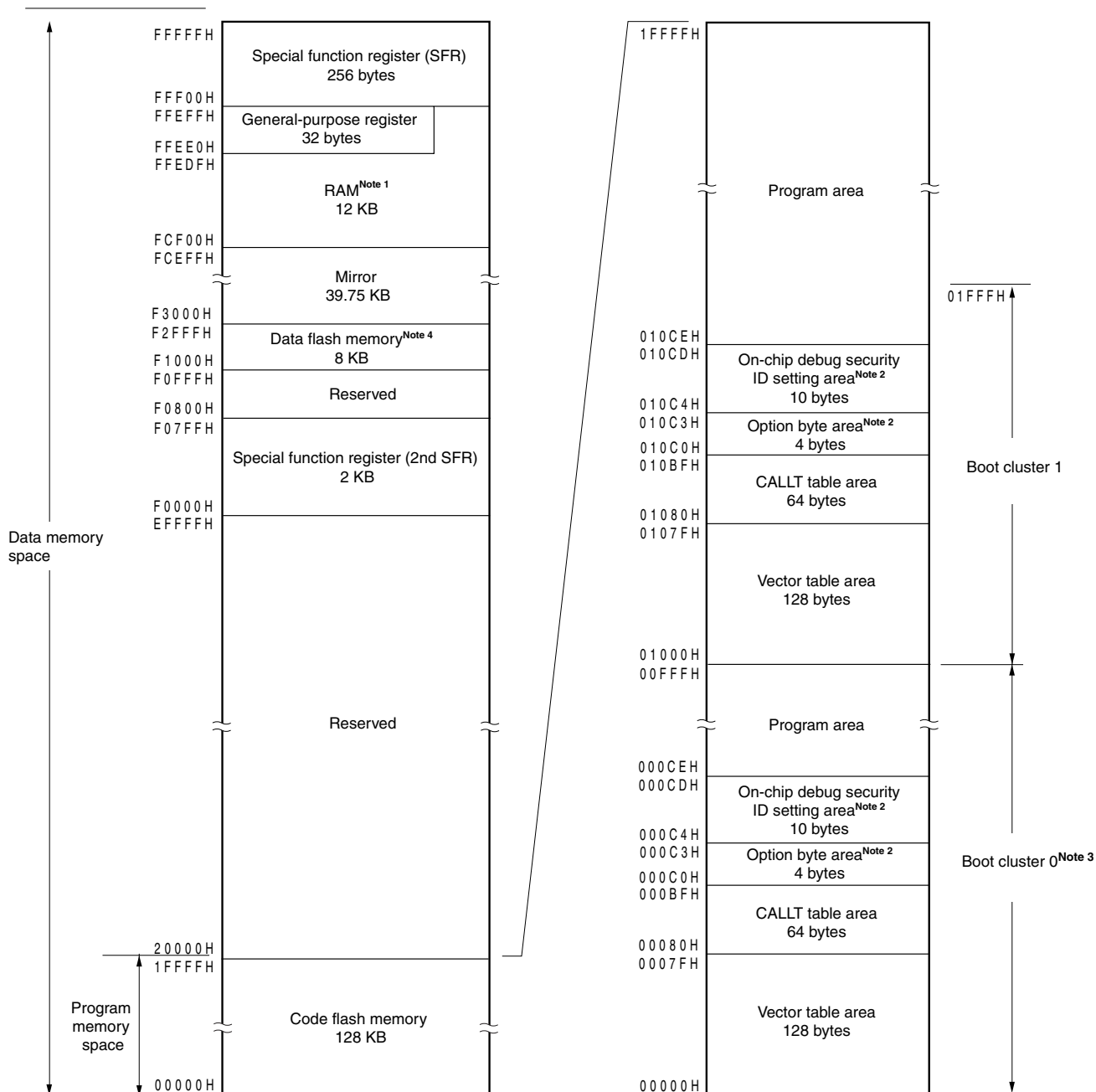
Figure 3-5. Memory Map (R5F100xF, R5F101xF(x = A to C, E to G, J, L, M, P))



- Notes**
1. Instructions can be executed from the RAM area excluding the general-purpose register area.
  2. When boot swap is not used: Set the option bytes to 000C0H to 000C3H, and the on-chip debug security IDs to 000C4H to 000CDH.  
When boot swap is used: Set the option bytes to 000C0H to 000C3H and 010C0H to 010C3H, and the on-chip debug security IDs to 000C4H to 000CDH and 010C4H to 010CDH.
  3. Writing boot cluster 0 can be prohibited depending on the setting of security (see 25.6 Security Setting).
  4. R5F100xF only.

**Caution** When executing instructions from the RAM area while RAM parity error resets are enabled (RPERDIS = 1), be sure to initialize the used RAM area + 10 bytes.

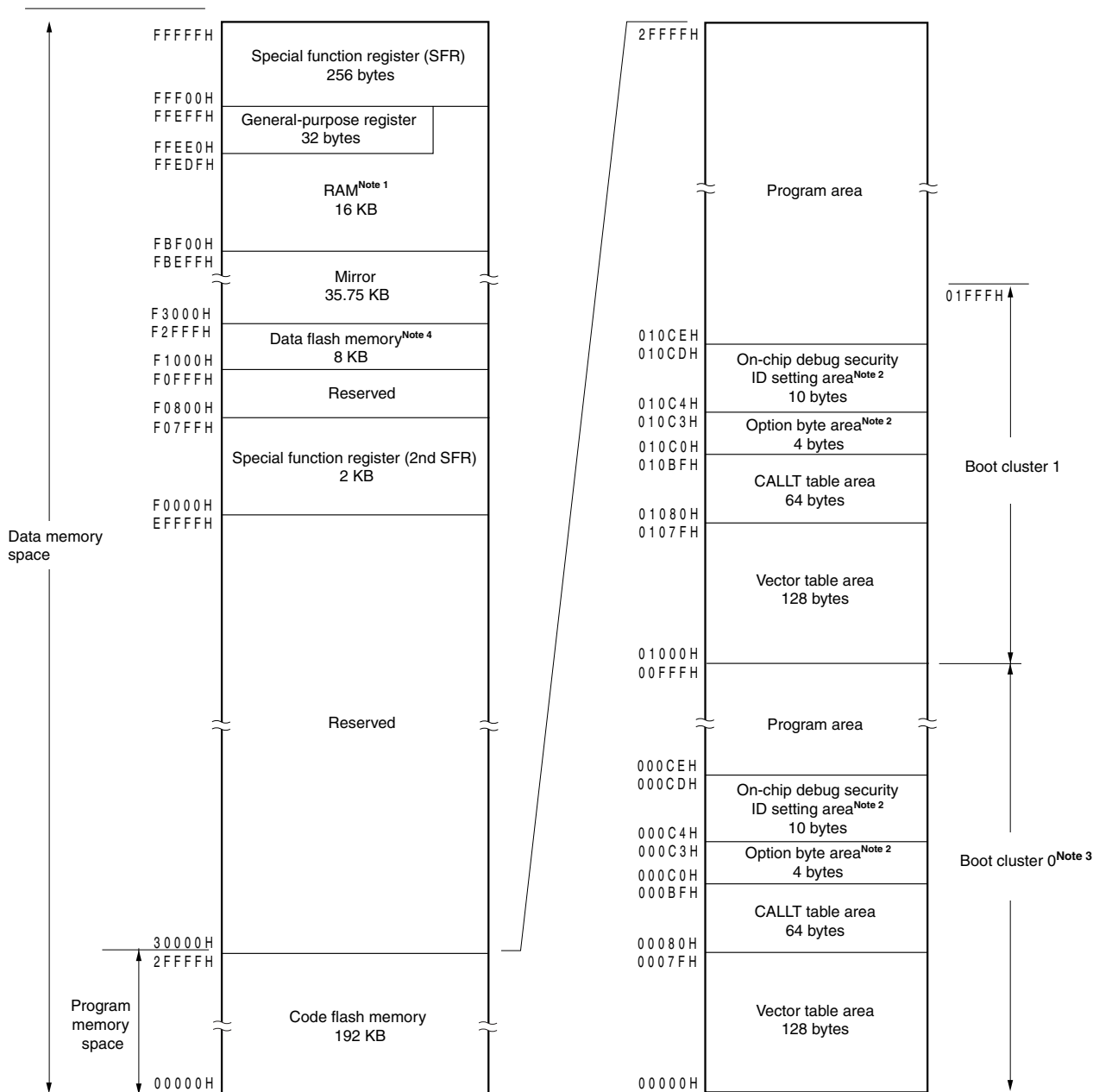
Figure 3-6. Memory Map (R5F100xG, R5F101xG(x = A to C, E to G, J, L, M, P))



- Notes**
1. Instructions can be executed from the RAM area excluding the general-purpose register area.
  2. When boot swap is not used: Set the option bytes to 000C0H to 000C3H, and the on-chip debug security IDs to 000C4H to 000CDH.  
When boot swap is used: Set the option bytes to 000C0H to 000C3H and 010C0H to 010C3H, and the on-chip debug security IDs to 000C4H to 000CDH and 010C4H to 010CDH.
  3. Writing boot cluster 0 can be prohibited depending on the setting of security (see 25.6 Security Setting).
  4. R5F100xG only.

**Caution** When executing instructions from the RAM area while RAM parity error resets are enabled (RPERDIS = 1), be sure to initialize the used RAM area + 10 bytes.

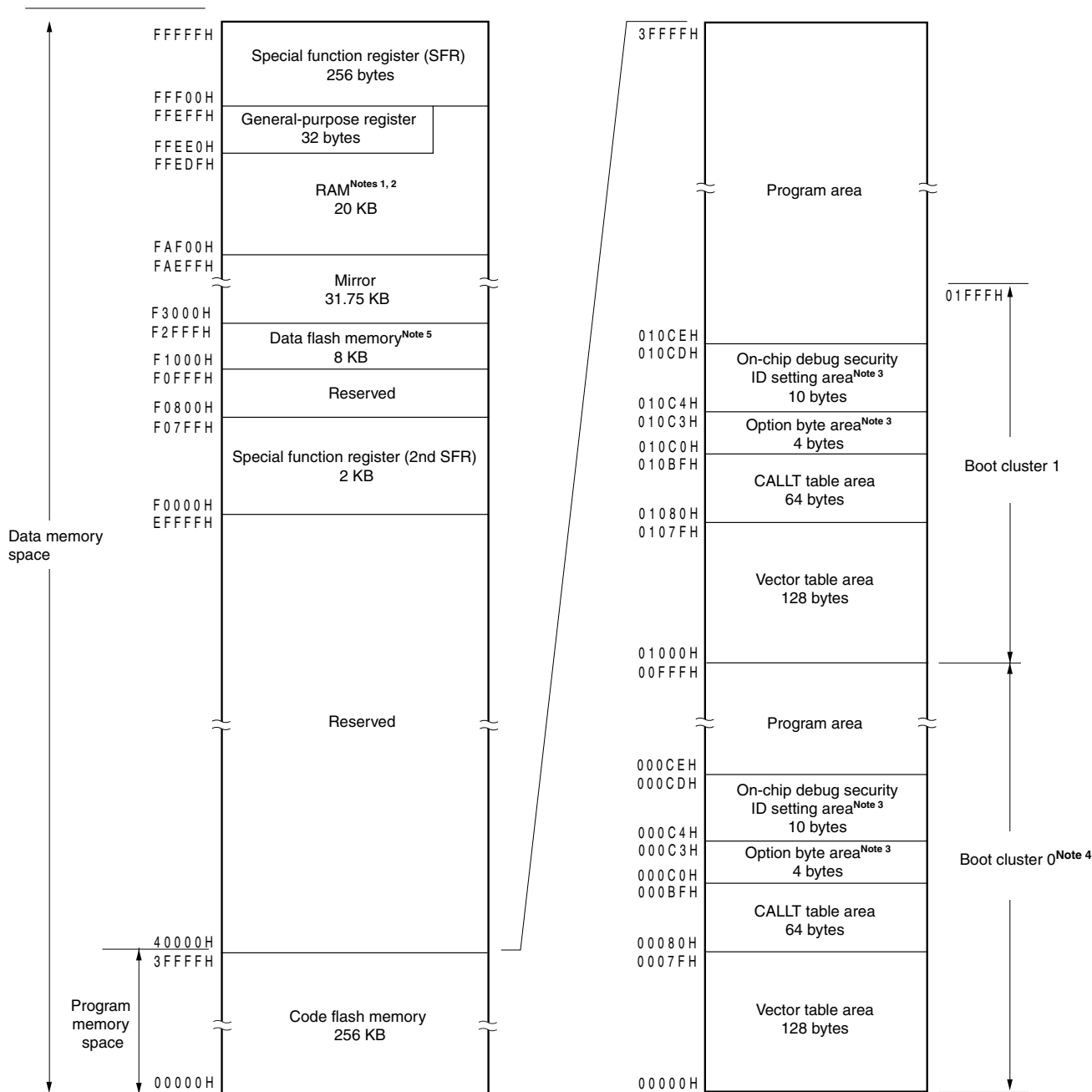
Figure 3-7. Memory Map (R5F100xH, R5F101xH(x = E to G, J, L, M, P, S))



- Notes**
1. Instructions can be executed from the RAM area excluding the general-purpose register area.
  2. When boot swap is not used: Set the option bytes to 000C0H to 000C3H, and the on-chip debug security IDs to 000C4H to 000CDH.  
 When boot swap is used: Set the option bytes to 000C0H to 000C3H and 010C0H to 010C3H, and the on-chip debug security IDs to 000C4H to 000CDH and 010C4H to 010CDH.
  3. Writing boot cluster 0 can be prohibited depending on the setting of security (see 25.6 Security Setting).
  4. R5F100xH only.

**Caution** When executing instructions from the RAM area while RAM parity error resets are enabled (RPERDIS = 1), be sure to initialize the used RAM area + 10 bytes.

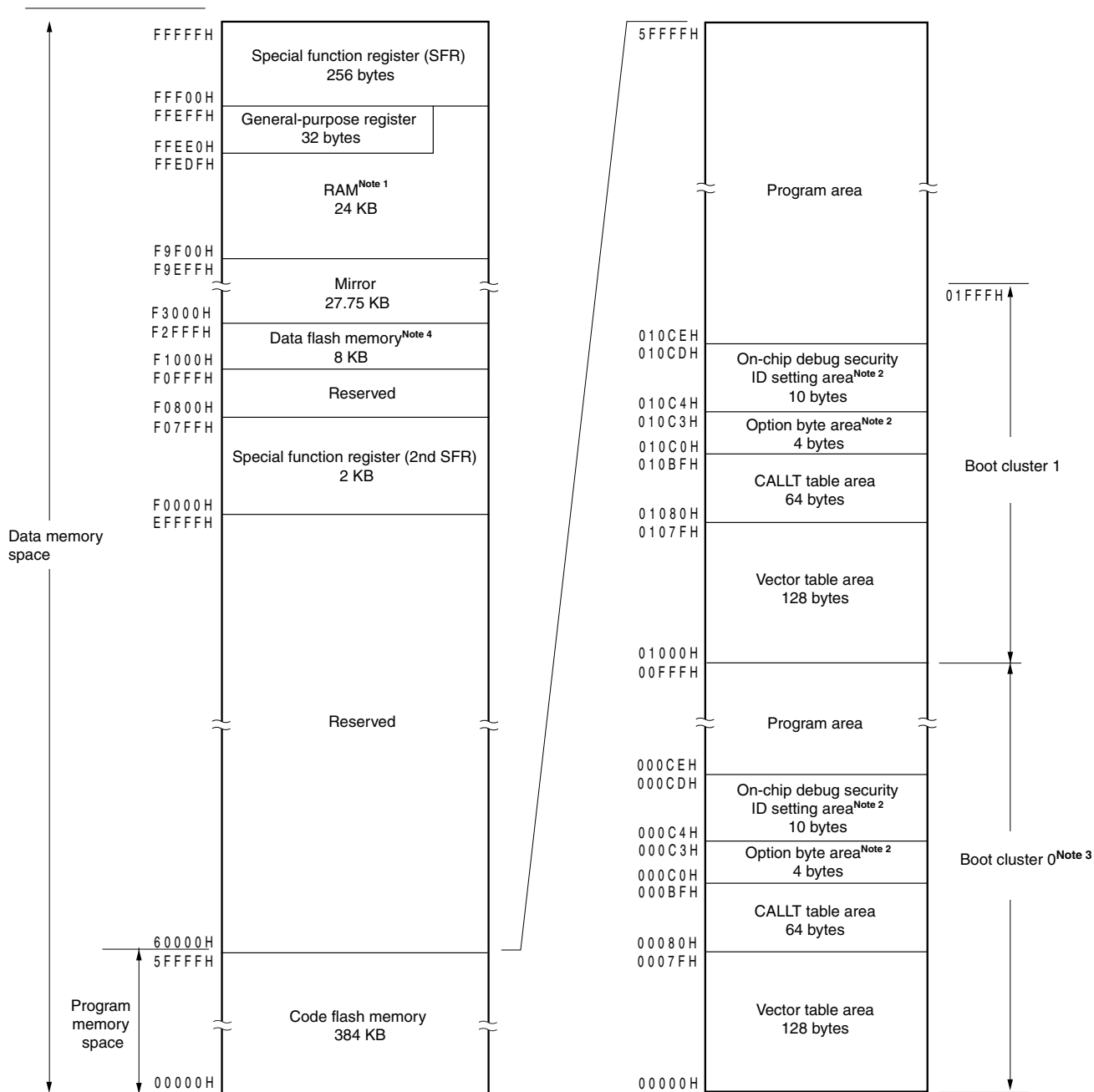
Figure 3-8. Memory Map (R5F100xJ, R5F101xJ(x = F, G, J, L, M, P, S))



- <R> **Notes**
1. Use of the area FAF00H to FB309H is prohibited when using the self-programming function and data flash function, because this area is used for self-programming library (R5F100xJ, R5F101xJ (x = F, G, J, L, M, P only)).
  2. Instructions can be executed from the RAM area excluding the general-purpose register area.
  3. When boot swap is not used: Set the option bytes to 000C0H to 000C3H, and the on-chip debug security IDs to 000C4H to 000CDH.  
When boot swap is used: Set the option bytes to 000C0H to 000C3H and 010C0H to 010C3H, and the on-chip debug security IDs to 000C4H to 000CDH and 010C4H to 010CDH.
  4. Writing boot cluster 0 can be prohibited depending on the setting of security (see 25.6 Security Setting).
  5. R5F100xJ only.

**Caution** When executing instructions from the RAM area while RAM parity error resets are enabled (RPERDIS = 1), be sure to initialize the used RAM area + 10 bytes.

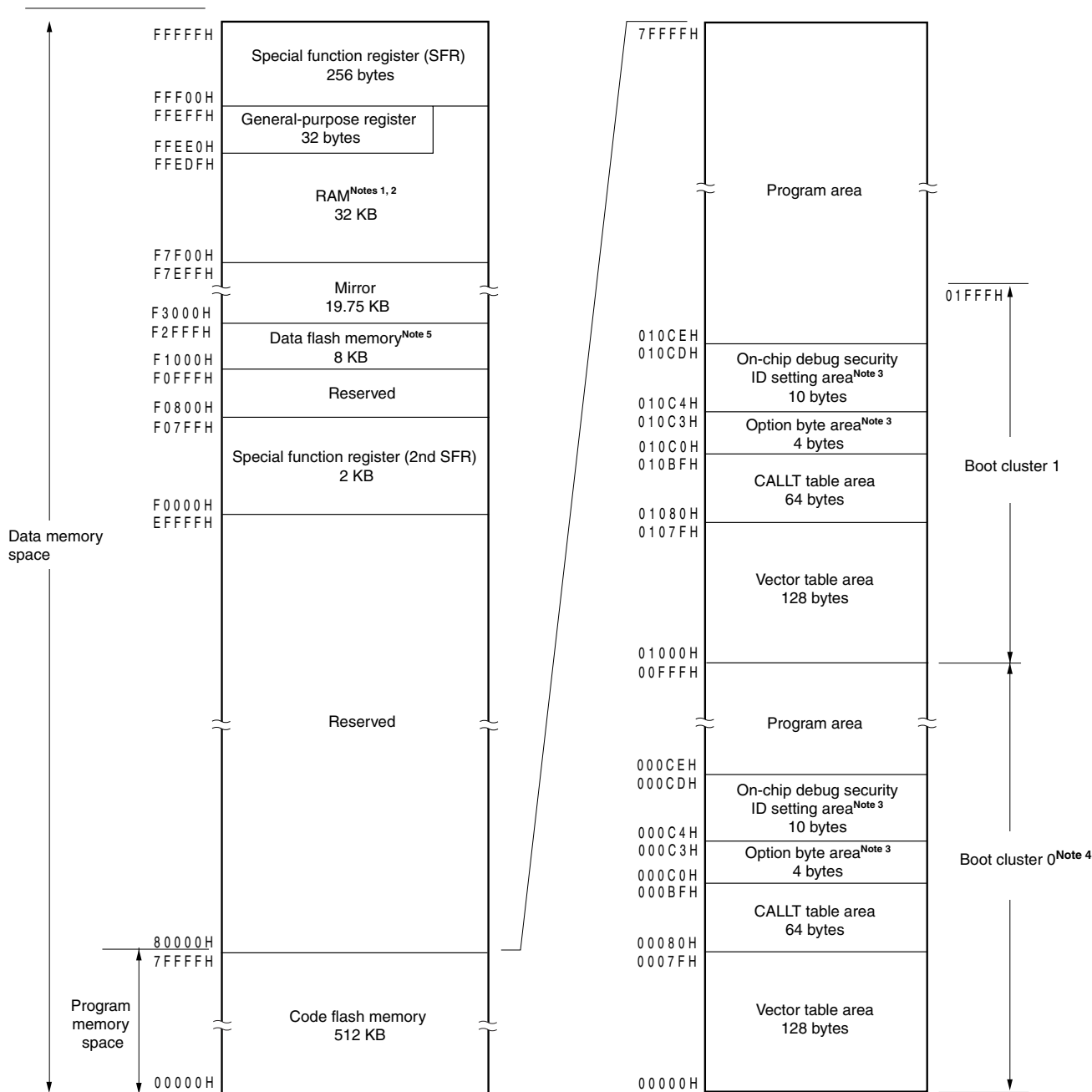
Figure 3-9. Memory Map (R5F100xK, R5F101xK(x = F, G, J, L, M, P, S))



- Notes**
- Instructions can be executed from the RAM area excluding the general-purpose register area.
  - When boot swap is not used: Set the option bytes to 000C0H to 000C3H, and the on-chip debug security IDs to 000C4H to 000CDH.  
When boot swap is used: Set the option bytes to 000C0H to 000C3H and 010C0H to 010C3H, and the on-chip debug security IDs to 000C4H to 000CDH and 010C4H to 010CDH.
  - Writing boot cluster 0 can be prohibited depending on the setting of security (see 25.6 Security Setting).
  - R5F100xK only.

**Caution** When executing instructions from the RAM area while RAM parity error resets are enabled (RPERDIS = 1), be sure to initialize the used RAM area + 10 bytes.

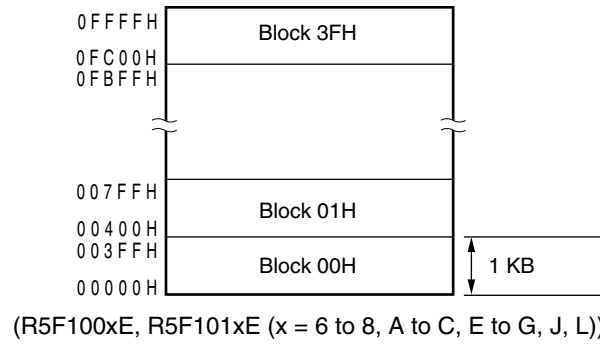
Figure 3-10. Memory Map (R5F100xL, R5F101xL(x = F, G, J, L, M, P, S))



- <R> **Notes**
- Use of the area F7F00H to F8309H is prohibited when using the self-programming function and data flash function, because this area is used for self-programming library.
  - Instructions can be executed from the RAM area excluding the general-purpose register area.
  - When boot swap is not used: Set the option bytes to 000C0H to 000C3H, and the on-chip debug security IDs to 000C4H to 000CDH.  
When boot swap is used: Set the option bytes to 000C0H to 000C3H and 010C0H to 010C3H, and the on-chip debug security IDs to 000C4H to 000CDH and 010C4H to 010CDH.
  - Writing boot cluster 0 can be prohibited depending on the setting of security (see **25.6 Security Setting**).
  - R5F100xL only.

**Caution** When executing instructions from the RAM area while RAM parity error resets are enabled (RPERDIS = 1), be sure to initialize the used RAM area + 10 bytes.

**Remark** The flash memory is divided into blocks (one block = 1 KB). For the address values and block numbers, see **Table 3-1 Correspondence Between Address Values and Block Numbers in Flash Memory.**





Correspondence between the address values and block numbers in the flash memory are shown below.

**Table 3-1. Correspondence Between Address Values and Block Numbers in Flash Memory (1/4)**

Address Value	Block Number	Address Value	Block Number	Address Value	Block Number	Address Value	Block Number
00000H to 003FFH	00H	08000H to 083FFH	20H	10000H to 103FFH	40H	18000H to 183FFH	60H
00400H to 007FFH	01H	08400H to 087FFH	21H	10400H to 107FFH	41H	18400H to 187FFH	61H
00800H to 00BFFH	02H	08800H to 08BFFH	22H	10800H to 10BFFH	42H	18800H to 18BFFH	62H
00C00H to 00FFFH	03H	08C00H to 08FFFH	23H	10C00H to 10FFFH	43H	18C00H to 18FFFH	63H
01000H to 013FFH	04H	09000H to 093FFH	24H	11000H to 113FFH	44H	19000H to 193FFH	64H
01400H to 017FFH	05H	09400H to 097FFH	25H	11400H to 117FFH	45H	19400H to 197FFH	65H
01800H to 01BFFH	06H	09800H to 09BFFH	26H	11800H to 11BFFH	46H	19800H to 19BFFH	66H
01C00H to 01FFFH	07H	09C00H to 09FFFH	27H	11C00H to 11FFFH	47H	19C00H to 19FFFH	67H
02000H to 023FFH	08H	0A000H to 0A3FFH	28H	12000H to 123FFH	48H	1A000H to 1A3FFH	68H
02400H to 027FFH	09H	0A400H to 0A7FFH	29H	12400H to 127FFH	49H	1A400H to 1A7FFH	69H
02800H to 02BFFH	0AH	0A800H to 0ABFFH	2AH	12800H to 12BFFH	4AH	1A800H to 1ABFFH	6AH
02C00H to 02FFFH	0BH	0AC00H to 0AFFFH	2BH	12C00H to 12FFFH	4BH	1AC00H to 1AFFFH	6BH
03000H to 033FFH	0CH	0B000H to 0B3FFH	2CH	13000H to 133FFH	4CH	1B000H to 1B3FFH	6CH
03400H to 037FFH	0DH	0B400H to 0B7FFH	2DH	13400H to 137FFH	4DH	1B400H to 1B7FFH	6DH
03800H to 03BFFH	0EH	0B800H to 0BBFFH	2EH	13800H to 13BFFH	4EH	1B800H to 1BBFFH	6EH
03C00H to 03FFFH	0FH	0BC00H to 0BFFFH	2FH	13C00H to 13FFFH	4FH	1BC00H to 1BFFFH	6FH
04000H to 043FFH	10H	0C000H to 0C3FFH	30H	14000H to 143FFH	50H	1C000H to 1C3FFH	70H
04400H to 047FFH	11H	0C400H to 0C7FFH	31H	14400H to 147FFH	51H	1C400H to 1C7FFH	71H
04800H to 04BFFH	12H	0C800H to 0CBFFH	32H	14800H to 14BFFH	52H	1C800H to 1CBFFH	72H
04C00H to 04FFFH	13H	0CC00H to 0CFFFH	33H	14C00H to 14FFFH	53H	1CC00H to 1CFFFH	73H
05000H to 053FFH	14H	0D000H to 0D3FFH	34H	15000H to 153FFH	54H	1D000H to 1D3FFH	74H
05400H to 057FFH	15H	0D400H to 0D7FFH	35H	15400H to 157FFH	55H	1D400H to 1D7FFH	75H
05800H to 05BFFH	16H	0D800H to 0DBFFH	36H	15800H to 15BFFH	56H	1D800H to 1DBFFH	76H
05C00H to 05FFFH	17H	0DC00H to 0DFFFH	37H	15C00H to 15FFFH	57H	1DC00H to 1DFFFH	77H
06000H to 063FFH	18H	0E000H to 0E3FFH	38H	16000H to 163FFH	58H	1E000H to 1E3FFH	78H
06400H to 067FFH	19H	0E400H to 0E7FFH	39H	16400H to 167FFH	59H	1E400H to 1E7FFH	79H
06800H to 06BFFH	1AH	0E800H to 0EBFFH	3AH	16800H to 16BFFH	5AH	1E800H to 1EBFFH	7AH
06C00H to 06FFFH	1BH	0EC00H to 0EFFFH	3BH	16C00H to 16FFFH	5BH	1EC00H to 1EFFFH	7BH
07000H to 073FFH	1CH	0F000H to 0F3FFH	3CH	17000H to 173FFH	5CH	1F000H to 1F3FFH	7CH
07400H to 077FFH	1DH	0F400H to 0F7FFH	3DH	17400H to 177FFH	5DH	1F400H to 1F7FFH	7DH
07800H to 07BFFH	1EH	0F800H to 0FBFFH	3EH	17800H to 17BFFH	5EH	1F800H to 1FBFFH	7EH
07C00H to 07FFFH	1FH	0FC00H to 0FFFFH	3FH	17C00H to 17FFFH	5FH	1FC00H to 1FFFFH	7FH

Table 3-1. Correspondence Between Address Values and Block Numbers in Flash Memory (2/4)

Address Value	Block Number	Address Value	Block Number	Address Value	Block Number	Address Value	Block Number
20000H to 203FFH	80H	28000H to 283FFH	A0H	30000H to 303FFH	C0H	38000H to 383FFH	E0H
20400H to 207FFH	81H	28400H to 287FFH	A1H	30400H to 307FFH	C1H	38400H to 387FFH	E1H
20800H to 20BFFH	82H	28800H to 28BFFH	A2H	30800H to 30BFFH	C2H	38800H to 38BFFH	E2H
20C00H to 20FFFH	83H	28C00H to 28FFFH	A3H	30C00H to 30FFFH	C3H	38C00H to 38FFFH	E3H
21000H to 213FFH	84H	29000H to 293FFH	A4H	31000H to 313FFH	C4H	39000H to 393FFH	E4H
21400H to 217FFH	85H	29400H to 297FFH	A5H	31400H to 317FFH	C5H	39400H to 397FFH	E5H
21800H to 21BFFH	86H	29800H to 29BFFH	A6H	31800H to 31BFFH	C6H	39800H to 39BFFH	E6H
21C00H to 21FFFH	87H	29C00H to 29FFFH	A7H	31C00H to 31FFFH	C7H	39C00H to 39FFFH	E7H
22000H to 223FFH	88H	2A000H to 2A3FFH	A8H	32000H to 323FFH	C8H	3A000H to 3A3FFH	E8H
22400H to 227FFH	89H	2A400H to 2A7FFH	A9H	32400H to 327FFH	C9H	3A400H to 3A7FFH	E9H
22800H to 22BFFH	8AH	2A800H to 2ABFFH	AAH	32800H to 32BFFH	CAH	3A800H to 3ABFFH	EAH
22C00H to 22FFFH	8BH	2AC00H to 2AFFFH	ABH	32C00H to 32FFFH	CBH	3AC00H to 3AFFFH	EBH
23000H to 233FFH	8CH	2B000H to 2B3FFH	ACH	33000H to 333FFH	CCH	3B000H to 3B3FFH	ECH
23400H to 237FFH	8DH	2B400H to 2B7FFH	ADH	33400H to 337FFH	CDH	3B400H to 3B7FFH	EDH
23800H to 23BFFH	8EH	2B800H to 2BBFFH	AEH	33800H to 33BFFH	CEH	3B800H to 3BBFFH	EEH
23C00H to 23FFFH	8FH	2BC00H to 2BFFFH	AFH	33C00H to 33FFFH	CFH	3BC00H to 3BFFFH	EFH
24000H to 243FFH	90H	2C000H to 2C3FFH	B0H	34000H to 343FFH	D0H	3C000H to 3C3FFH	F0H
24400H to 247FFH	91H	2C400H to 2C7FFH	B1H	34400H to 347FFH	D1H	3C400H to 3C7FFH	F1H
24800H to 24BFFH	92H	2C800H to 2CBFFH	B2H	34800H to 34BFFH	D2H	3C800H to 3CBFFH	F2H
24C00H to 24FFFH	93H	2CC00H to 2CFFFH	B3H	34C00H to 34FFFH	D3H	3CC00H to 3CFFFH	F3H
25000H to 253FFH	94H	2D000H to 2D3FFH	B4H	35000H to 353FFH	D4H	3D000H to 3D3FFH	F4H
25400H to 257FFH	95H	2D400H to 2D7FFH	B5H	35400H to 357FFH	D5H	3D400H to 3D7FFH	F5H
25800H to 25BFFH	96H	2D800H to 2DBFFH	B6H	35800H to 35BFFH	D6H	3D800H to 3DBFFH	F6H
25C00H to 25FFFH	97H	2DC00H to 2DFFFH	B7H	35C00H to 35FFFH	D7H	3DC00H to 3DFFFH	F7H
26000H to 263FFH	98H	2E000H to 2E3FFH	B8H	36000H to 363FFH	D8H	3E000H to 3E3FFH	F8H
26400H to 267FFH	99H	2E400H to 2E7FFH	B9H	36400H to 367FFH	D9H	3E400H to 3E7FFH	F9H
26800H to 26BFFH	9AH	2E800H to 2EBFFH	BAH	36800H to 36BFFH	DAH	3E800H to 3EBFFH	FAH
26C00H to 26FFFH	9BH	2EC00H to 2EFFFH	BBH	36C00H to 36FFFH	DBH	3EC00H to 3EFFFH	FBH
27000H to 273FFH	9CH	2F000H to 2F3FFH	BCH	37000H to 373FFH	DCH	3F000H to 3F3FFH	FCH
27400H to 277FFH	9DH	2F400H to 2F7FFH	BDH	37400H to 377FFH	DDH	3F400H to 3F7FFH	FDH
27800H to 27BFFH	9EH	2F800H to 2FBFFH	BEH	37800H to 37BFFH	DEH	3F800H to 3FBFFH	FEH
27C00H to 27FFFH	9FH	2FC00H to 2FFFFH	BFH	37C00H to 37FFFH	DFH	3FC00H to 3FFFFH	FFH

Table 3-1. Correspondence Between Address Values and Block Numbers in Flash Memory (3/4)

Address Value	Block Number	Address Value	Block Number	Address Value	Block Number	Address Value	Block Number
40000H to 403FFH	100H	48000H to 483FFH	120H	50000H to 503FFH	140H	58000H to 583FFH	160H
40400H to 407FFH	101H	48400H to 487FFH	121H	50400H to 507FFH	141H	58400H to 587FFH	161H
40800H to 40BFFH	102H	48800H to 48BFFH	122H	50800H to 50BFFH	142H	58800H to 58BFFH	162H
40C00H to 40FFFH	103H	48C00H to 48FFFH	123H	50C00H to 50FFFH	143H	58C00H to 58FFFH	163H
41000H to 413FFH	104H	49000H to 493FFH	124H	51000H to 513FFH	144H	59000H to 593FFH	164H
41400H to 417FFH	105H	49400H to 497FFH	125H	51400H to 517FFH	145H	59400H to 597FFH	165H
41800H to 41BFFH	106H	49800H to 49BFFH	126H	51800H to 51BFFH	146H	59800H to 59BFFH	166H
41C00H to 41FFFH	107H	49C00H to 49FFFH	127H	51C00H to 51FFFH	147H	59C00H to 59FFFH	167H
42000H to 423FFH	108H	4A000H to 4A3FFH	128H	52000H to 523FFH	148H	5A000H to 5A3FFH	168H
42400H to 427FFH	109H	4A400H to 4A7FFH	129H	52400H to 527FFH	149H	5A400H to 5A7FFH	169H
42800H to 42BFFH	10AH	4A800H to 4ABFFH	12AH	52800H to 52BFFH	14AH	5A800H to 5ABFFH	16AH
42C00H to 42FFFH	10BH	4AC00H to 4AFFFH	12BH	52C00H to 52FFFH	14BH	5AC00H to 5AFFFH	16BH
43000H to 433FFH	10CH	4B000H to 4B3FFH	12CH	53000H to 533FFH	14CH	5B000H to 5B3FFH	16CH
43400H to 437FFH	10DH	4B400H to 4B7FFH	12DH	53400H to 537FFH	14DH	5B400H to 5B7FFH	16DH
43800H to 43BFFH	10EH	4B800H to 4BBFFH	12EH	53800H to 53BFFH	14EH	5B800H to 5BBFFH	16EH
43C00H to 43FFFH	10FH	4BC00H to 4BFFFH	12FH	53C00H to 53FFFH	14FH	5BC00H to 5BFFFH	16FH
44000H to 443FFH	110H	4C000H to 4C3FFH	130H	54000H to 543FFH	150H	5C000H to 5C3FFH	170H
44400H to 447FFH	111H	4C400H to 4C7FFH	131H	54400H to 547FFH	151H	5C400H to 5C7FFH	171H
44800H to 44BFFH	112H	4C800H to 4CBFFH	132H	54800H to 54BFFH	152H	5C800H to 5CBFFH	172H
44C00H to 44FFFH	113H	4CC00H to 4CFFFH	133H	54C00H to 54FFFH	153H	5CC00H to 5CFFFH	173H
45000H to 453FFH	114H	4D000H to 4D3FFH	134H	55000H to 553FFH	154H	5D000H to 5D3FFH	174H
45400H to 457FFH	115H	4D400H to 4D7FFH	135H	55400H to 557FFH	155H	5D400H to 5D7FFH	175H
45800H to 45BFFH	116H	4D800H to 4DBFFH	136H	55800H to 55BFFH	156H	5D800H to 5DBFFH	176H
45C00H to 45FFFH	117H	4DC00H to 4DFFFH	137H	55C00H to 55FFFH	157H	5DC00H to 5DFFFH	177H
46000H to 463FFH	118H	4E000H to 4E3FFH	138H	56000H to 563FFH	158H	5E000H to 5E3FFH	178H
46400H to 467FFH	119H	4E400H to 4E7FFH	139H	56400H to 567FFH	159H	5E400H to 5E7FFH	179H
46800H to 46BFFH	11AH	4E800H to 4EBFFH	13AH	56800H to 56BFFH	15AH	5E800H to 5EBFFH	17AH
46C00H to 46FFFH	11BH	4EC00H to 4EFFFH	13BH	56C00H to 56FFFH	15BH	5EC00H to 5EFFFH	17BH
47000H to 473FFH	11CH	4F000H to 4F3FFH	13CH	57000H to 573FFH	15CH	5F000H to 5F3FFH	17CH
47400H to 477FFH	11DH	4F400H to 4F7FFH	13DH	57400H to 577FFH	15DH	5F400H to 5F7FFH	17DH
47800H to 47BFFH	11EH	4F800H to 4FBFFH	13EH	57800H to 57BFFH	15EH	5F800H to 5FBFFH	17EH
47C00H to 47FFFH	11FH	4FC00H to 4FFFFH	13FH	57C00H to 57FFFH	15FH	5FC00H to 5FFFFH	17FH

Table 3-1. Correspondence Between Address Values and Block Numbers in Flash Memory (4/4)

Address Value	Block Number	Address Value	Block Number	Address Value	Block Number	Address Value	Block Number
60000H to 603FFH	180H	68000H to 683FFH	1A0H	70000H to 703FFH	1C0H	78000H to 783FFH	1E0H
60400H to 607FFH	181H	68400H to 687FFH	1A1H	70400H to 707FFH	1C1H	78400H to 787FFH	1E1H
60800H to 60BFFH	182H	68800H to 68BFFH	1A2H	70800H to 70BFFH	1C2H	78800H to 78BFFH	1E2H
60C00H to 60FFFH	183H	68C00H to 68FFFH	1A3H	70C00H to 70FFFH	1C3H	78C00H to 78FFFH	1E3H
61000H to 613FFH	184H	69000H to 693FFH	1A4H	71000H to 713FFH	1C4H	79000H to 793FFH	1E4H
61400H to 617FFH	185H	69400H to 697FFH	1A5H	71400H to 717FFH	1C5H	79400H to 797FFH	1E5H
61800H to 61BFFH	186H	69800H to 69BFFH	1A6H	71800H to 71BFFH	1C6H	79800H to 79BFFH	1E6H
61C00H to 61FFFH	187H	69C00H to 69FFFH	1A7H	71C00H to 71FFFH	1C7H	79C00H to 79FFFH	1E7H
62000H to 623FFH	188H	6A000H to 6A3FFH	1A8H	72000H to 723FFH	1C8H	7A000H to 7A3FFH	1E8H
62400H to 627FFH	189H	6A400H to 6A7FFH	1A9H	72400H to 727FFH	1C9H	7A400H to 7A7FFH	1E9H
62800H to 62BFFH	18AH	6A800H to 6ABFFH	1AAH	72800H to 72BFFH	1CAH	7A800H to 7ABFFH	1EAH
62C00H to 62FFFH	18BH	6AC00H to 6AFFFH	1ABH	72C00H to 72FFFH	1CBH	7AC00H to 7AFFFH	1EBH
63000H to 633FFH	18CH	6B000H to 6B3FFH	1ACH	73000H to 733FFH	1CCH	7B000H to 7B3FFH	1ECH
63400H to 637FFH	18DH	6B400H to 6B7FFH	1ADH	73400H to 737FFH	1CDH	7B400H to 7B7FFH	1EDH
63800H to 63BFFH	18EH	6B800H to 6BBFFH	1AEH	73800H to 73BFFH	1CEH	7B800H to 7BBFFH	1EEH
63C00H to 63FFFH	18FH	6BC00H to 6BFFFH	1AFH	73C00H to 73FFFH	1CFH	7BC00H to 7BFFFH	1EFH
64000H to 643FFH	190H	6C000H to 6C3FFH	1B0H	74000H to 743FFH	1D0H	7C000H to 7C3FFH	1F0H
64400H to 647FFH	191H	6C400H to 6C7FFH	1B1H	74400H to 747FFH	1D1H	7C400H to 7C7FFH	1F1H
64800H to 64BFFH	192H	6C800H to 6CBFFH	1B2H	74800H to 74BFFH	1D2H	7C800H to 7CBFFH	1F2H
64C00H to 64FFFH	193H	6CC00H to 6CFFFH	1B3H	74C00H to 74FFFH	1D3H	7CC00H to 7CFFFH	1F3H
65000H to 653FFH	194H	6D000H to 6D3FFH	1B4H	75000H to 753FFH	1D4H	7D000H to 7D3FFH	1F4H
65400H to 657FFH	195H	6D400H to 6D7FFH	1B5H	75400H to 757FFH	1D5H	7D400H to 7D7FFH	1F5H
65800H to 65BFFH	196H	6D800H to 6DBFFH	1B6H	75800H to 75BFFH	1D6H	7D800H to 7DBFFH	1F6H
65C00H to 65FFFH	197H	6DC00H to 6DFFFH	1B7H	75C00H to 75FFFH	1D7H	7DC00H to 7DFFFH	1F7H
66000H to 663FFH	198H	6E000H to 6E3FFH	1B8H	76000H to 763FFH	1D8H	7E000H to 7E3FFH	1F8H
66400H to 667FFH	199H	6E400H to 6E7FFH	1B9H	76400H to 767FFH	1D9H	7E400H to 7E7FFH	1F9H
66800H to 66BFFH	19AH	6E800H to 6EBFFH	1BAH	76800H to 76BFFH	1DAH	7E800H to 7EBFFH	1FAH
66C00H to 66FFFH	19BH	6EC00H to 6EFFFH	1BBH	76C00H to 76FFFH	1DBH	7EC00H to 7EFFFH	1FBH
67000H to 673FFH	19CH	6F000H to 6F3FFH	1BCH	77000H to 773FFH	1DCH	7F000H to 7F3FFH	1FCH
67400H to 677FFH	19DH	6F400H to 6F7FFH	1BDH	77400H to 777FFH	1DDH	7F400H to 7F7FFH	1FDH
67800H to 67BFFH	19EH	6F800H to 6FBFFH	1BEH	77800H to 77BFFH	1DEH	7F800H to 7FBFFH	1FEH
67C00H to 67FFFH	19FH	6FC00H to 6FFFFH	1BFH	77C00H to 77FFFH	1DFH	7FC00H to 7FFFFH	1FFH

### 3.1.1 Internal program memory space

The internal program memory space stores the program and table data.

The RL78/G13 products incorporate internal ROM (flash memory), as shown below.

**Table 3-2. Internal ROM Capacity**

Part Number	Internal ROM	
	Structure	Capacity
R5F100xA, R5F101xA (x = 6 to 8, A to C, E to G)	Flash memory	16384 × 8 bits (00000H to 03FFFFH)
R5F100xC, R5F101xC (x = 6 to 8, A to C, E to G, J, L)		32768 × 8 bits (00000H to 07FFFFH)
R5F100xD, R5F101xD (x = 6 to 8, A to C, E to G, J, L)		49152 × 8 bits (00000H to 0BFFFFH)
R5F100xE, R5F101xE (x = 6 to 8, A to C, E to G, J, L)		65536 × 8 bits (00000H to 0FFFFH)
R5F100xF, R5F101xF (x = A to C, E to G, J, L, M, P)		98304 × 8 bits (00000H to 17FFFFH)
R5F100xG, R5F101xG (x = A to C, E to G, J, L, M, P)		131072 × 8 bits (00000H to 1FFFFH)
R5F100xH, R5F101xH (x = E to G, J, L, M, P, S)		196608 × 8 bits (00000H to 2FFFFH)
R5F100xJ, R5F101xJ (x = F, G, J, L, M, P, S)		262144 × 8 bits (00000H to 3FFFFH)
R5F100xK, R5F101xK (x = F, G, J, L, M, P, S)		393216 × 8 bits (00000H to 5FFFFH)
R5F100xL, R5F101xL (x = F, G, J, L, M, P, S)		524288 × 8 bits (00000H to 7FFFFH)

The internal program memory space is divided into the following areas.

#### (1) Vector table area

The 128-byte area 00000H to 0007FH is reserved as a vector table area. The program start addresses for branch upon reset or generation of each interrupt request are stored in the vector table area. Furthermore, the interrupt jump address is a 64 K address of 00000H to 0FFFFH, because the vector code is assumed to be 2 bytes.

Of the 16-bit address, the lower 8 bits are stored at even addresses and the higher 8 bits are stored at odd addresses.

To use the boot swap function, set a vector table also at 01000H to 0107FH.

Table 3-3. Vector Table (1/2)

Vector Table Address	Interrupt Source	128-pin	100-pin	80-pin	64-pin	52-pin	48-pin	44-pin	40-pin	36-pin	32-pin	30-pin	25-pin	24-pin	20-pin
0000H	RESET, POR, LVD, WDT, TRAP, IAW, RAMTOP	√	√	√	√	√	√	√	√	√	√	√	√	√	√
0004H	INTWDTI	√	√	√	√	√	√	√	√	√	√	√	√	√	√
0006H	INTLVI	√	√	√	√	√	√	√	√	√	√	√	√	√	√
0008H	INTP0	√	√	√	√	√	√	√	√	√	√	√	√	√	√
000AH	INTP1	√	√	√	√	√	√	√	√	√	√	√	√	√	–
000CH	INTP2	√	√	√	√	√	√	√	√	√	√	√	–	–	–
000EH	INTP3	√	√	√	√	√	√	√	√	√	√	√	√	√	√
0010H	INTP4	√	√	√	√	√	√	√	√	√	√	√	√	√	–
0012H	INTP5	√	√	√	√	√	√	√	√	√	√	√	√	√	√
0014H	INTST2/INTCSI20/INTIIC20	√	√	√	√	√	√	√	√	√	√	√	–	–	–
0016H	INTSR2/INTCSI21/INTIIC21	√	√	√	√	√	√	√	√	√	Note 1	Note 1	–	–	–
0018H	INTSRE2	√	√	√	√	√	√	√	√	√	√	√	–	–	–
	INTTM11H	√	√	√	–	–	–	–	–	–	–	–	–	–	–
001AH	INTDMA0	√	√	√	√	√	√	√	√	√	√	√	√	√	√
001CH	INTDMA1	√	√	√	√	√	√	√	√	√	√	√	√	√	√
001EH	INTST0/INTCSI00/INTIIC00	√	√	√	√	√	√	√	√	√	√	√	√	√	√
0020H	INTSR0/INTCSI01/INTIIC01	√	√	√	√	√	√	Note 2	Note 2	Note 2	Note 2	Note 2	Note 2	Note 2	Note 2
0022H	INTSRE0	√	√	√	√	√	√	√	√	√	√	√	√	√	√
	INTTM01H	√	√	√	√	√	√	√	√	√	√	√	√	√	√
0024H	INTST1/INTCSI10/INTIIC10	√	√	√	√	Note 3	Note 3	Note 3	Note 3	Note 3	Note 3	Note 3	Note 3	Note 3	Note 3
0026H	INTSR1/INTCSI11/INTIIC11	√	√	√	√	√	√	√	√	√	√	√	√	√	√
<R> 0028H	INTSRE1	√	√	√	√	√	√	√	√	√	√	√	√	√	√
	INTTM03H	√	√	√	√	√	√	√	√	√	√	√	√	√	√
002AH	INTIICA0	√	√	√	√	√	√	√	√	√	√	√	√	√	–
002CH	INTTM00	√	√	√	√	√	√	√	√	√	√	√	√	√	√
002EH	INTTM01	√	√	√	√	√	√	√	√	√	√	√	√	√	√
0030H	INTTM02	√	√	√	√	√	√	√	√	√	√	√	√	√	√
0032H	INTTM03	√	√	√	√	√	√	√	√	√	√	√	√	√	√
0034H	INTAD	√	√	√	√	√	√	√	√	√	√	√	√	√	√
0036H	INTRTC	√	√	√	√	√	√	√	√	√	√	√	√	√	√
0038H	INTIT	√	√	√	√	√	√	√	√	√	√	√	√	√	√
003AH	INTKR	√	√	√	√	√	√	√	√	–	–	–	–	–	–
003CH	INTST3/INTCSI30/INTIIC30	√	√	√	–	–	–	–	–	–	–	–	–	–	–
003EH	INTSR3/INTCSI31/INTIIC31	√	√	√	–	–	–	–	–	–	–	–	–	–	–
0040H	INTTM13	√	√	√	–	–	–	–	–	–	–	–	–	–	–

- Notes 1. INTSR2 only.  
 2. INTSR0 only.  
 3. INTSR1 only.

Table 3-3. Vector Table (2/2)

Vector Table Address	Interrupt Source	128-pin	100-pin	80-pin	64-pin	52-pin	48-pin	44-pin	40-pin	36-pin	32-pin	30-pin	25-pin	24-pin	20-pin
0042H	INTTM04	√	√	√	√	√	√	√	√	√	√	√	√	√	√
0044H	INTTM05	√	√	√	√	√	√	√	√	√	√	√	√	√	√
0046H	INTTM06	√	√	√	√	√	√	√	√	√	√	√	√	√	√
0048H	INTTM07	√	√	√	√	√	√	√	√	√	√	√	√	√	√
004AH	INTP6	√	√	√	√	√	√	-	-	-	-	-	-	-	-
004CH	INTP7	√	√	√	√	-	-	-	-	-	-	-	-	-	-
004EH	INTP8	√	√	√	√	√	√	-	-	-	-	-	-	-	-
0050H	INTP9	√	√	√	√	√	√	-	-	-	-	-	-	-	-
0052H	INTP10	√	√	√	√	√	-	-	-	-	-	-	-	-	-
0054H	INTP11	√	√	√	√	√	-	-	-	-	-	-	-	-	-
0056H	INTTM10	√	√	√	-	-	-	-	-	-	-	-	-	-	-
0058H	INTTM11	√	√	√	-	-	-	-	-	-	-	-	-	-	-
005AH	INTTM12	√	√	√	-	-	-	-	-	-	-	-	-	-	-
005CH	INTSRE3	√	√	√	-	-	-	-	-	-	-	-	-	-	-
	INTTM13H	√	√	√	-	-	-	-	-	-	-	-	-	-	-
005EH	INTMD	√	√	√	√	√	√	√	√	√	√	√	√	√	√
0060H	INTIICA1	√	√	√	-	-	-	-	-	-	-	-	-	-	-
0062H	INTFL	√	√	√	√	√	√	√	√	√	√	√	√	√	√
0064H	INTDMA2	√	√	√	-	-	-	-	-	-	-	-	-	-	-
0066H	INTDMA3	√	√	√	-	-	-	-	-	-	-	-	-	-	-
0068H	INTTM14	√	-	-	-	-	-	-	-	-	-	-	-	-	-
006AH	INTTM15	√	-	-	-	-	-	-	-	-	-	-	-	-	-
006CH	INTTM16	√	-	-	-	-	-	-	-	-	-	-	-	-	-
006EH	INTTM17	√	-	-	-	-	-	-	-	-	-	-	-	-	-
007EH	BRK	√	√	√	√	√	√	√	√	√	√	√	√	√	√

**(2) CALLT instruction table area**

The 64-byte area 00080H to 000BFH can store the subroutine entry address of a 2-byte call instruction (CALLT). Set the subroutine entry address to a value in a range of 00000H to 0FFFFH (because an address code is of 2 bytes).

To use the boot swap function, set a CALLT instruction table also at 01080H to 010BFH.

**(3) Option byte area**

A 4-byte area of 000C0H to 000C3H can be used as an option byte area. Set the option byte at 010C0H to 010C3H when the boot swap is used. For details, see **CHAPTER 24 OPTION BYTE**.

**(4) On-chip debug security ID setting area**

A 10-byte area of 000C4H to 000CDH and 010C4H to 010CDH can be used as an on-chip debug security ID setting area. Set the on-chip debug security ID of 10 bytes at 000C4H to 000CDH when the boot swap is not used and at 000C4H to 000CDH and 010C4H to 010CDH when the boot swap is used. For details, see **CHAPTER 26 ON-CHIP DEBUG FUNCTION**.

**3.1.2 Mirror area**

The RL78/G13 mirrors the code flash area of 00000H to 0FFFFH, to F0000H to FFFFFH. The products with 96 KB or more flash memory mirror the code flash area of 00000H to 0FFFFH or 10000H to 1FFFFH, to F0000H to FFFFFH (the code flash area to be mirrored is set by the processor mode control register (PMC)).

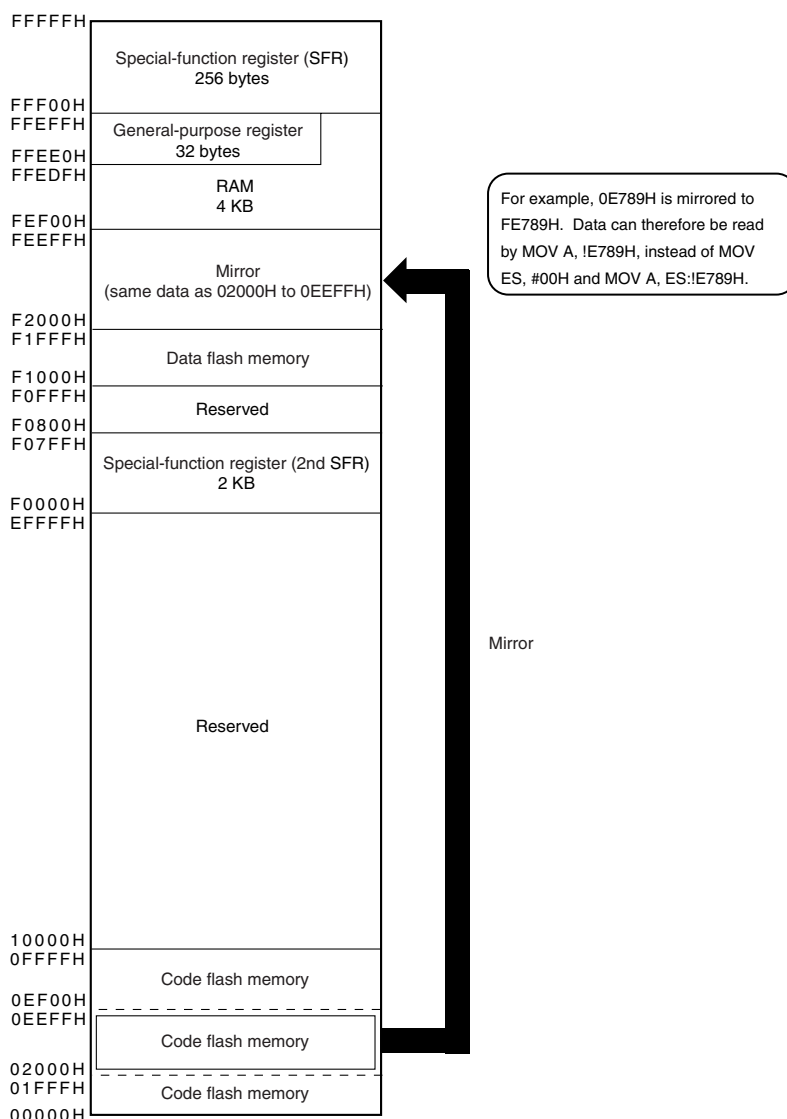
By reading data from F0000H to FFFFFH, an instruction that does not have the ES register as an operand can be used, and thus the contents of the code flash can be read with the shorter code. However, the code flash area is not mirrored to the SFR, extended SFR, RAM, and use prohibited areas.

See **3.1 Memory Space** for the mirror area of each product.

The mirror area can only be read and no instruction can be fetched from this area.

The following show examples.

<R> **Example R5F100xE (x = 6 to 8, A to C, E-G, J, L) (Flash memory: 64 KB, RAM: 4 KB)**



The PMC register is described below.



• **Processor mode control register (PMC)**

This register sets the flash memory space for mirroring to area from F0000H to FFFFFH. The PMC register can be set by a 1-bit or 8-bit memory manipulation instruction. Reset signal generation sets this register to 00H.

**Figure 3-11. Format of Configuration of Processor Mode Control Register (PMC)**

Address: FFFFEH After reset: 00H R/W

Symbol	7	6	5	4	3	2	1	<0>
PMC	0	0	0	0	0	0	0	MAA

MAA	Selection of flash memory space for mirroring to area from F0000H to FFFFFH
0	00000H to 0FFFFH is mirrored to F0000H to FFFFFH
1	10000H to 1FFFFH is mirrored to F0000H to FFFFFH <sup>Note</sup>

**Note** This setting is prohibited in products with 64 KB or less flash memory

- Cautions**
1. In products with 64 KB or less flash memory, be sure to clear bit 0 (MAA) of this register to 0 (default value).
  2. Set the PMC register only once during the initial settings prior to operating the DMA controller. Rewriting the PMC register other than during the initial settings is prohibited.
  3. After setting the PMC register, wait for at least one instruction and access the mirror area.

### 3.1.3 Internal data memory space

The RL78/G13 products incorporate the following RAMs.

**Table 3-4. Internal RAM Capacity**

Part Number	Internal RAM
R5F100xA, R5F101xA (x = 6 to 8, A to C, E to G)	2048 × 8 bits (FF700H to FFEFFH)
R5F100xC, R5F101xC (x = 6 to 8, A to C, E to G, J, L)	
R5F100xD, R5F101xD (x = 6 to 8, A to C, E to G, J, L)	3072 × 8 bits (FF300H to FFEFFH)
R5F100xE, R5F101xE (x = 6 to 8, A to C, E to G, J, L)	4096 × 8 bits (FEF00H to FFEFFH)
R5F100xF, R5F101xF (x = A to C, E to G, J, L, M, P)	8192 × 8 bits (FDF00H to FFEFFH)
R5F100xG, R5F101xG (x = A to C, E to G, J, L, M, P)	12288 × 8 bits (FCF00H to FFEFFH)
R5F100xH, R5F101xH (x = E to G, J, L, M, P, S)	16384 × 8 bits (FBF00H to FFEFFH)
R5F100xJ, R5F101xJ (x = F, G, J, L, M, P, S)	20480 × 8 bits (FAF00H to FFEFFH)
R5F100xK, R5F101xK (x = F, G, J, L, M, P, S)	24576 × 8 bits (F9F00H to FFEFFH)
R5F100xL, R5F101xL (x = F, G, J, L, M, P, S)	32768 × 8 bits (F7F00H to FFEFFH)

The internal RAM can be used as a data area and a program area where instructions are written and executed. Four general-purpose register banks consisting of eight 8-bit registers per bank are assigned to the 32-byte area of FFEE0H to FFEFFH of the internal RAM area. However, instructions cannot be executed by using the general-purpose registers.

The internal RAM is used as stack memory.

**Cautions 1. It is prohibited to use the general-purpose register (FFEE0H to FFEFFH) space for fetching instructions or as a stack area.**

<R>

**2. The internal RAM in the following products cannot be used as stack memory when using the self-programming function and data flash function.**

R5F100xD, R5F101xD (x = 6 to 8, A to C, E to G, J, L): FF300H to FF309H

R5F100xE, R5F101xE (x = 6 to 8, A to C, E to G, J, L): FEF00H to FF309H

R5F100xJ, R5F101xJ (x = F, G, J, L, M, P): FAF00H to FB309H

R5F100xL, R5F101xL (x = F, G, J, L, M, P, S): F7F00H to F8309H

### 3.1.4 Special function register (SFR) area

On-chip peripheral hardware special function registers (SFRs) are allocated in the area FFF00H to FFFFFH (see **Table 3-5** in **3.2.4 Special function registers (SFRs)**).

**Caution** Do not access addresses to which SFRs are not assigned.

### 3.1.5 Extended special function register (2nd SFR: 2nd Special Function Register) area

On-chip peripheral hardware special function registers (2nd SFRs) are allocated in the area F0000H to F07FFH (see **Table 3-6** in **3.2.5 Extended Special function registers (2nd SFRs: 2nd Special Function Registers)**).

SFRs other than those in the SFR area (FFF00H to FFFFFH) are allocated to this area. An instruction that accesses the extended SFR area, however, is 1 byte longer than an instruction that accesses the SFR area.

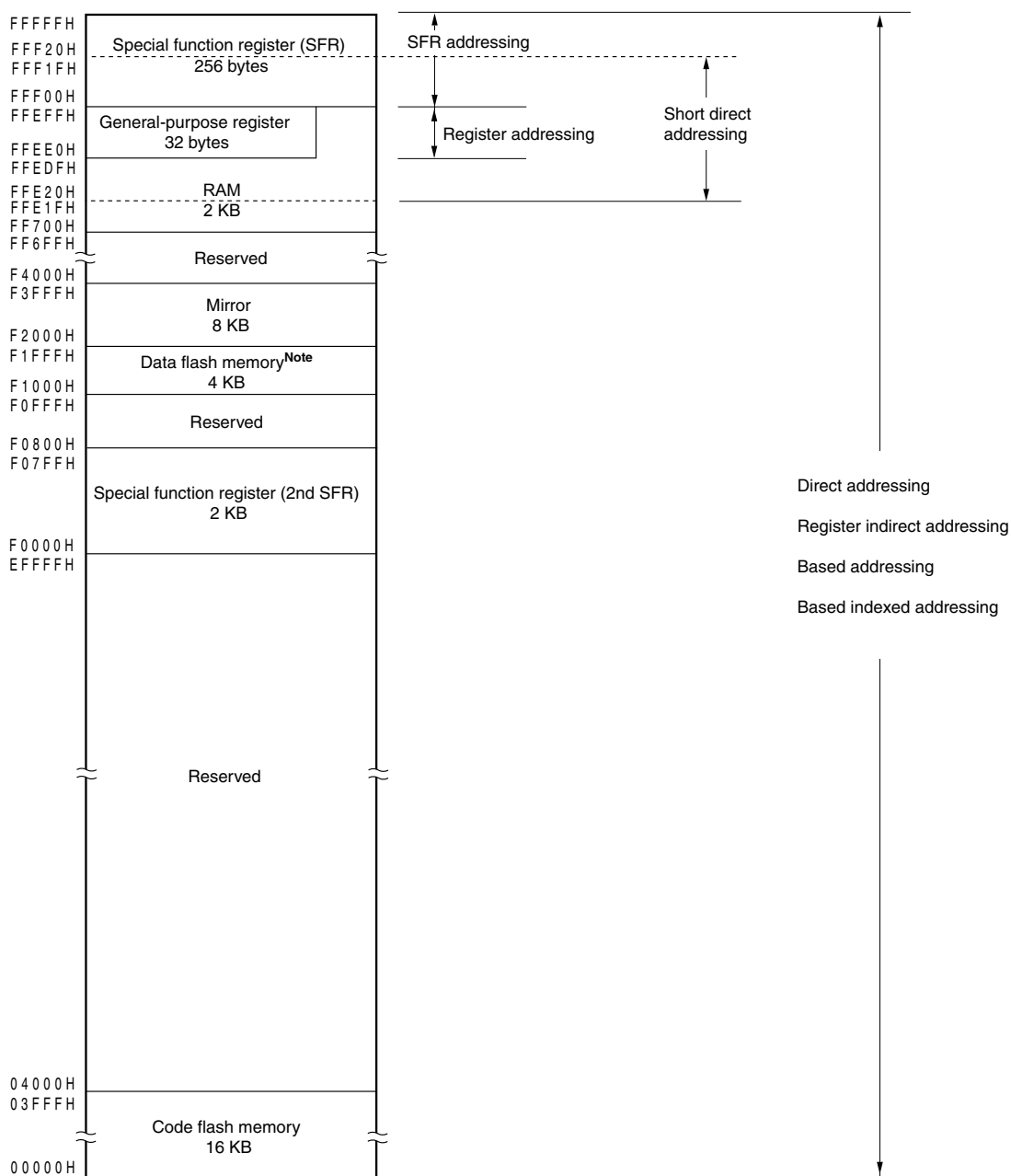
**Caution** Do not access addresses to which extended SFRs are not assigned.

### 3.1.6 Data memory addressing

Addressing refers to the method of specifying the address of the instruction to be executed next or the address of the register or memory relevant to the execution of instructions.

Several addressing modes are provided for addressing the memory relevant to the execution of instructions for the RL78/G13, based on operability and other considerations. For areas containing data memory in particular, special addressing methods designed for the functions of the special function registers (SFR) and general-purpose registers are available for use. Figures 3-12 to 3-21 show correspondence between data memory and addressing. For details of each addressing, see 3.4 Addressing for Processing Data Addresses.

<R> Figure 3-12. Correspondence Between Data Memory and Addressing (R5F100xA, R5F101xA(x = 6 to 8, A to C, E to G))

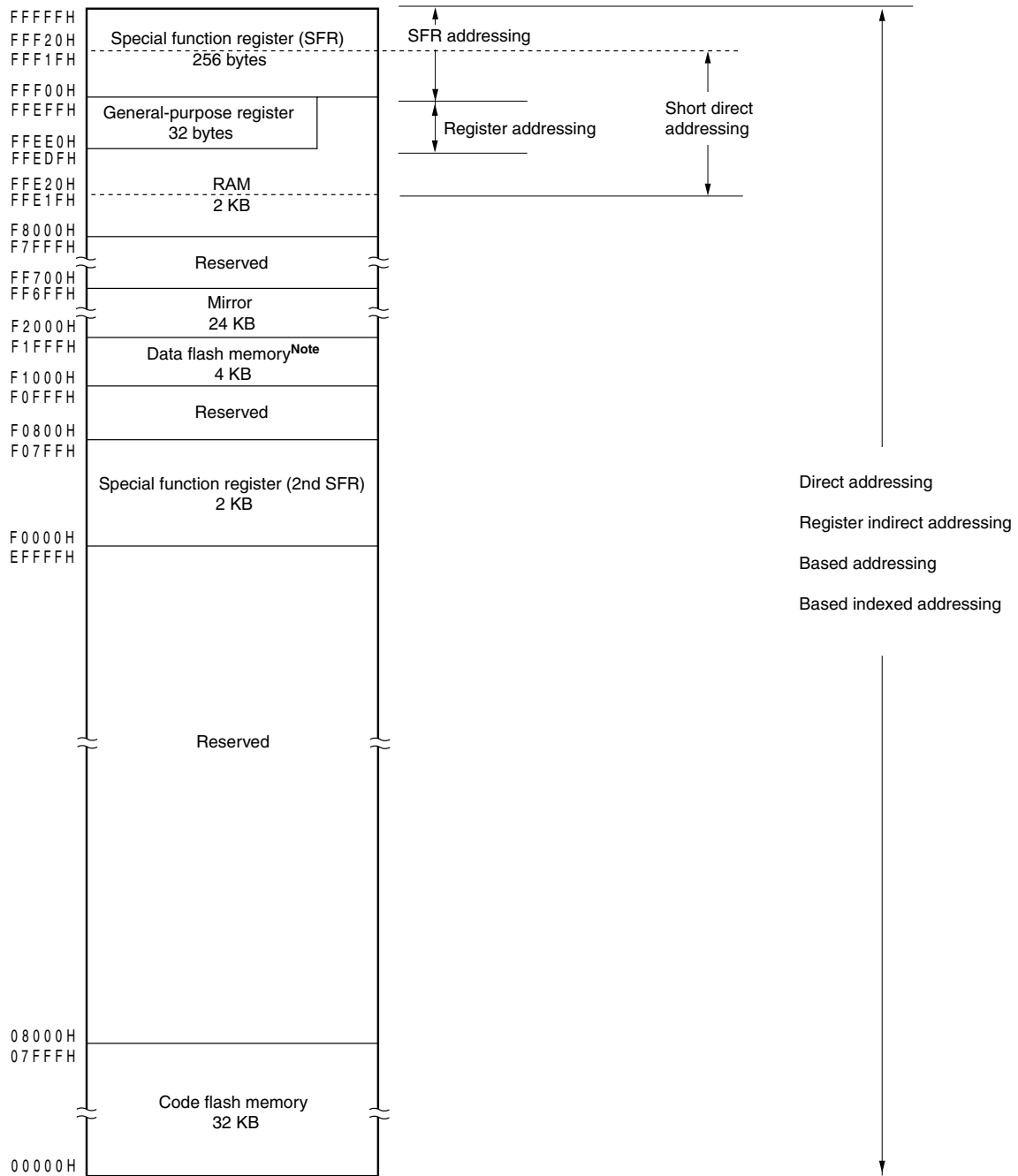


**Note** R5F100xA only.

**Caution** When executing instructions from the RAM area while RAM parity error resets are enabled (RPERDIS = 1), be sure to initialize the used RAM area + 10 bytes.

<R>

**Figure 3-13. Correspondence Between Data Memory and Addressing  
(R5F100xC, R5F101xC (x = 6 to 8, A to C, E to G, J, L))**

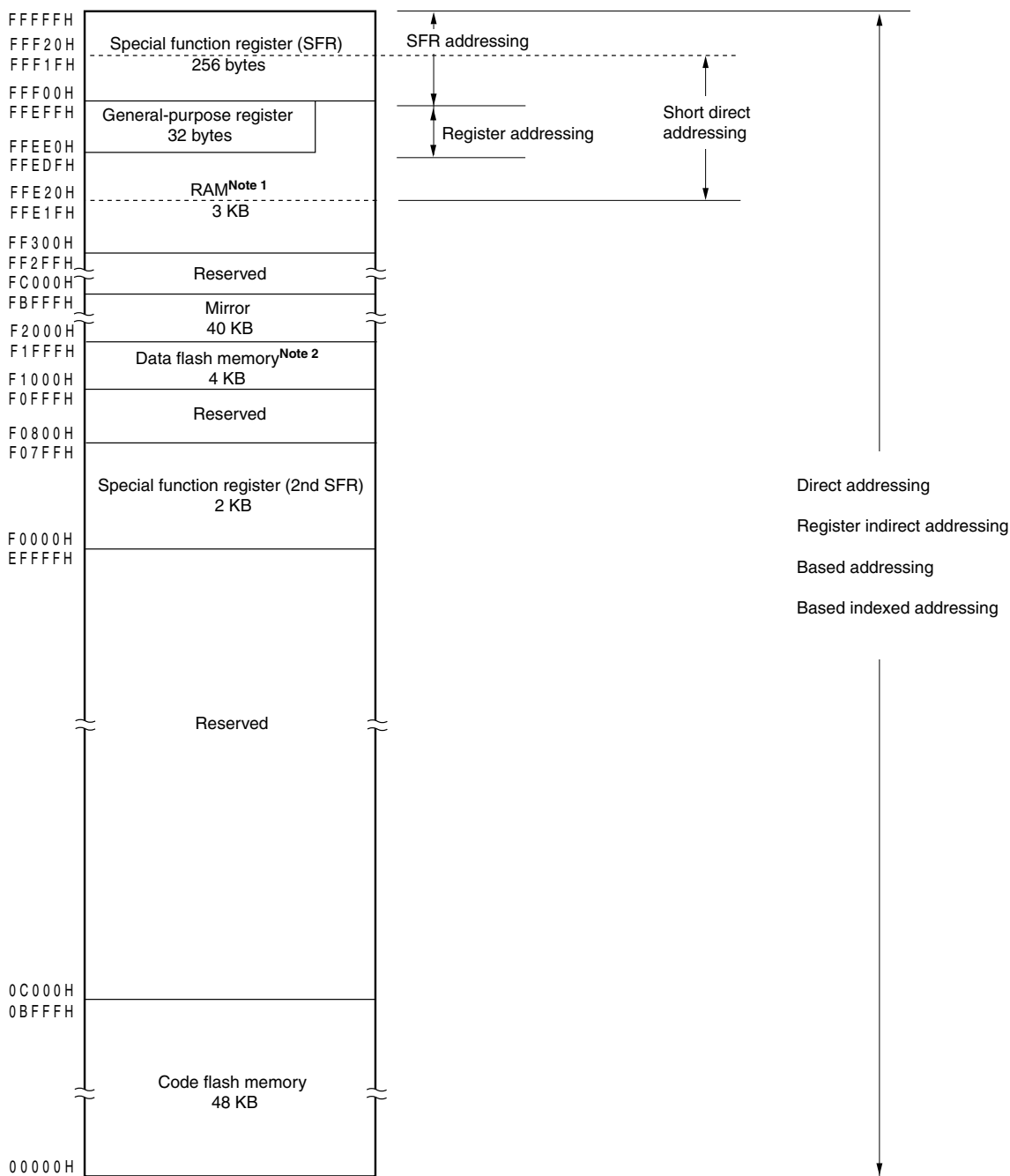


**Note** R5F100xC only.

**Caution** When executing instructions from the RAM area while RAM parity error resets are enabled (RPERDIS = 1), be sure to initialize the used RAM area + 10 bytes.

<R>

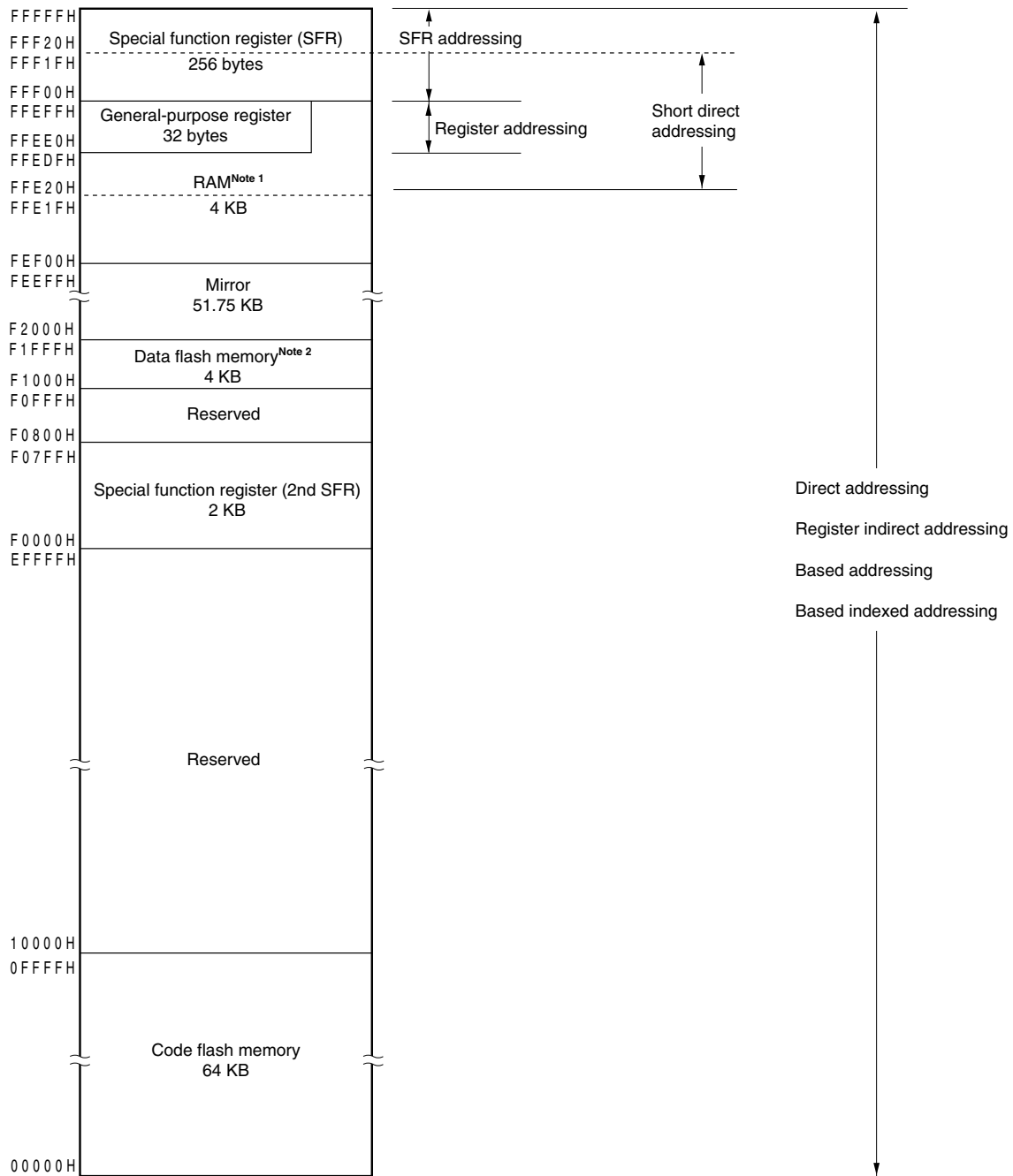
**Figure 3-14. Correspondence Between Data Memory and Addressing  
(R5F100xD, R5F101xD (x = 6 to 8, A to C, E to G, J, L))**



- <R> **Notes 1.** Use of the area FF300H to FF309H is prohibited when using the self-programming function and data flash function, because this area is used for self-programming library.
- 2.** R5F100xD only.

**Caution** When executing instructions from the RAM area while RAM parity error resets are enabled (RPERDIS = 1), be sure to initialize the used RAM area + 10 bytes.

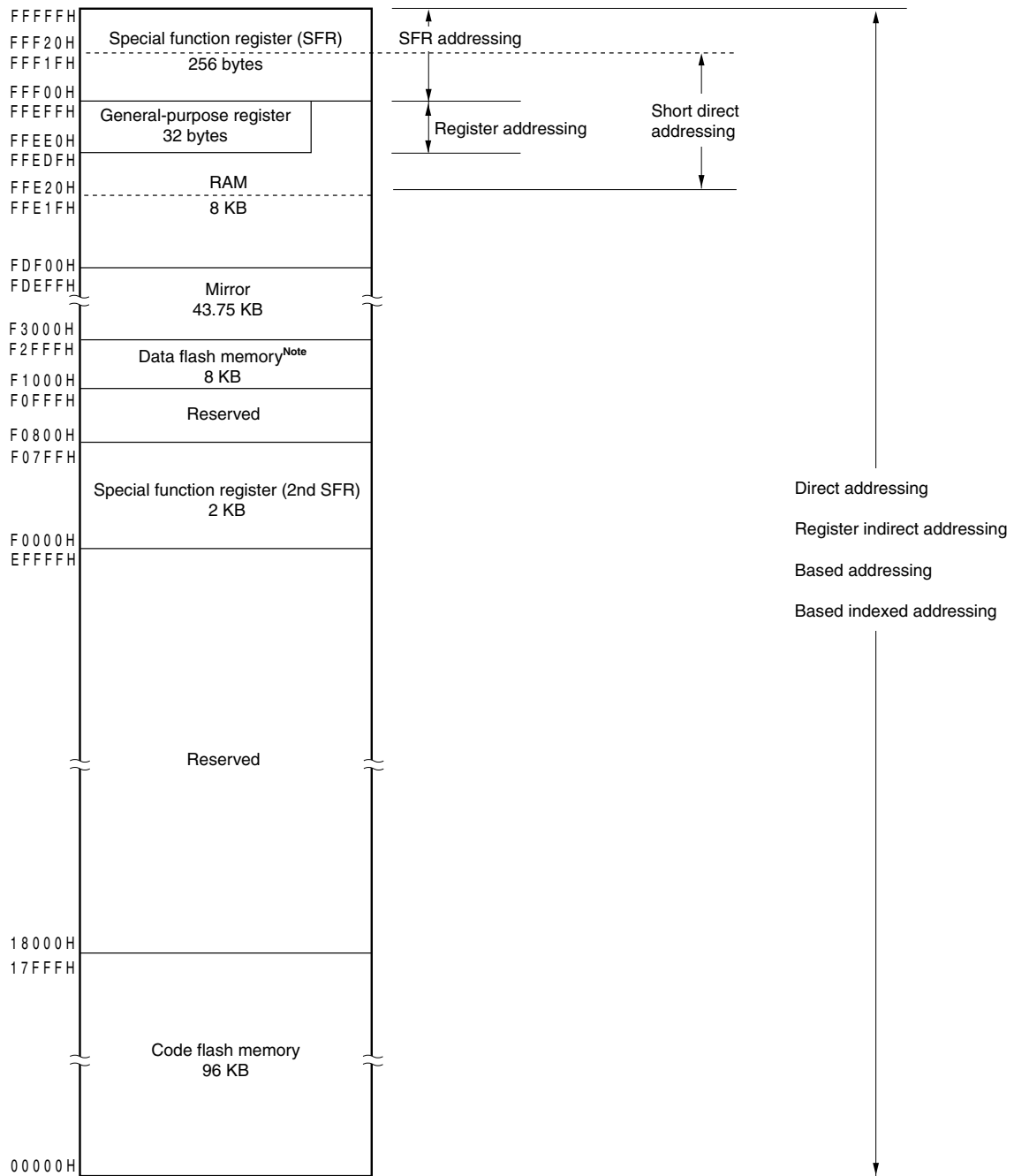
**Figure 3-15. Correspondence Between Data Memory and Addressing  
(R5F100xE, R5F101xE (x = 6 to 8, A to C, E to G, J, L))**



- <R> **Notes 1.** Use of the area FEF00H to FF309H is prohibited when using the self-programming function and data flash function, because this area is used for self-programming library.
- 2.** R5F100xE only.

**Caution** When executing instructions from the RAM area while RAM parity error resets are enabled (RPERDIS = 1), be sure to initialize the used RAM area + 10 bytes.

**Figure 3-16. Correspondence Between Data Memory and Addressing  
(R5F100xF, R5F101xF (x = A to C, E to G, J, L, M, P))**

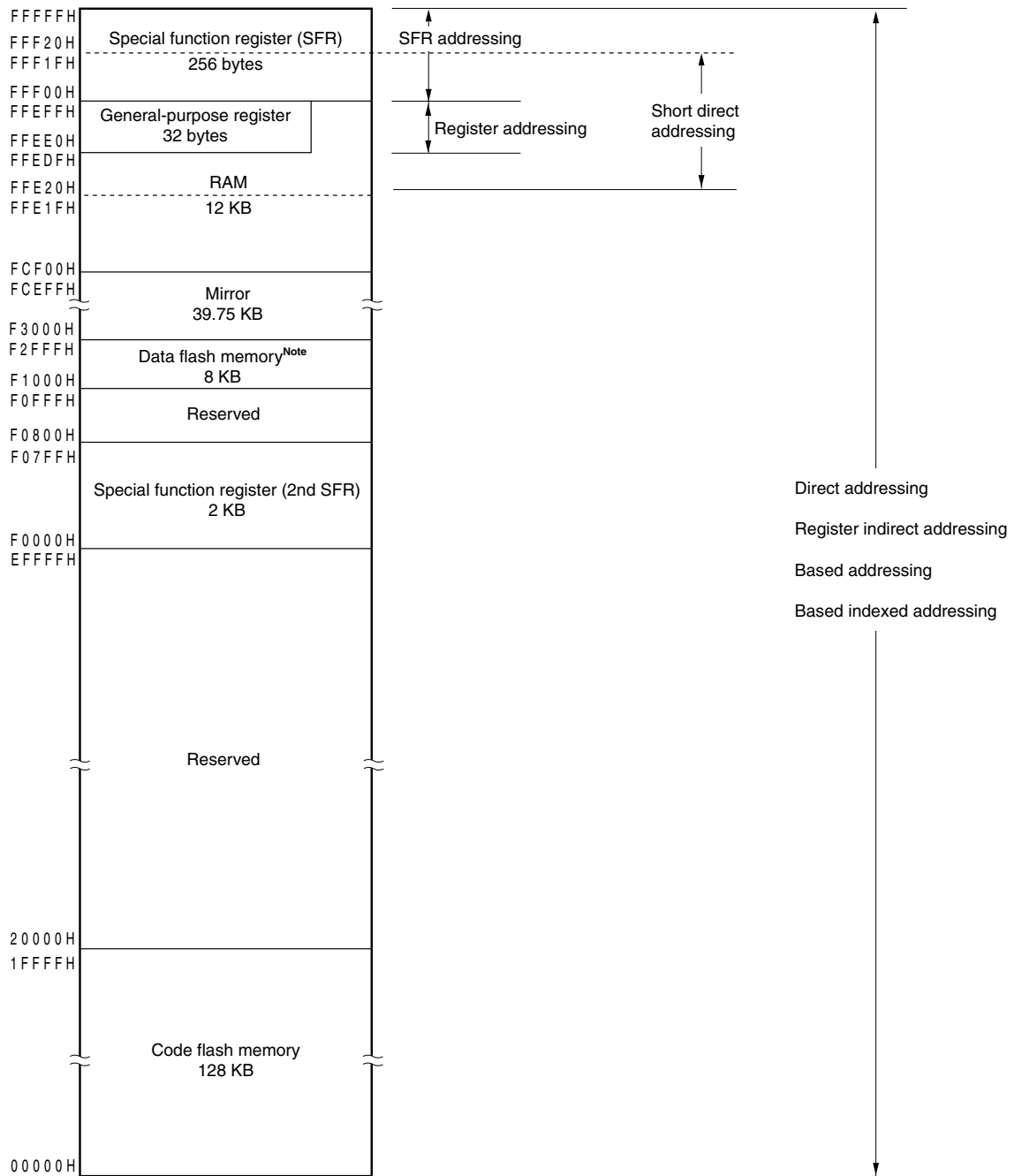


**Note** R5F100xF only.

**Caution** When executing instructions from the RAM area while RAM parity error resets are enabled (RPERDIS = 1), be sure to initialize the used RAM area + 10 bytes.



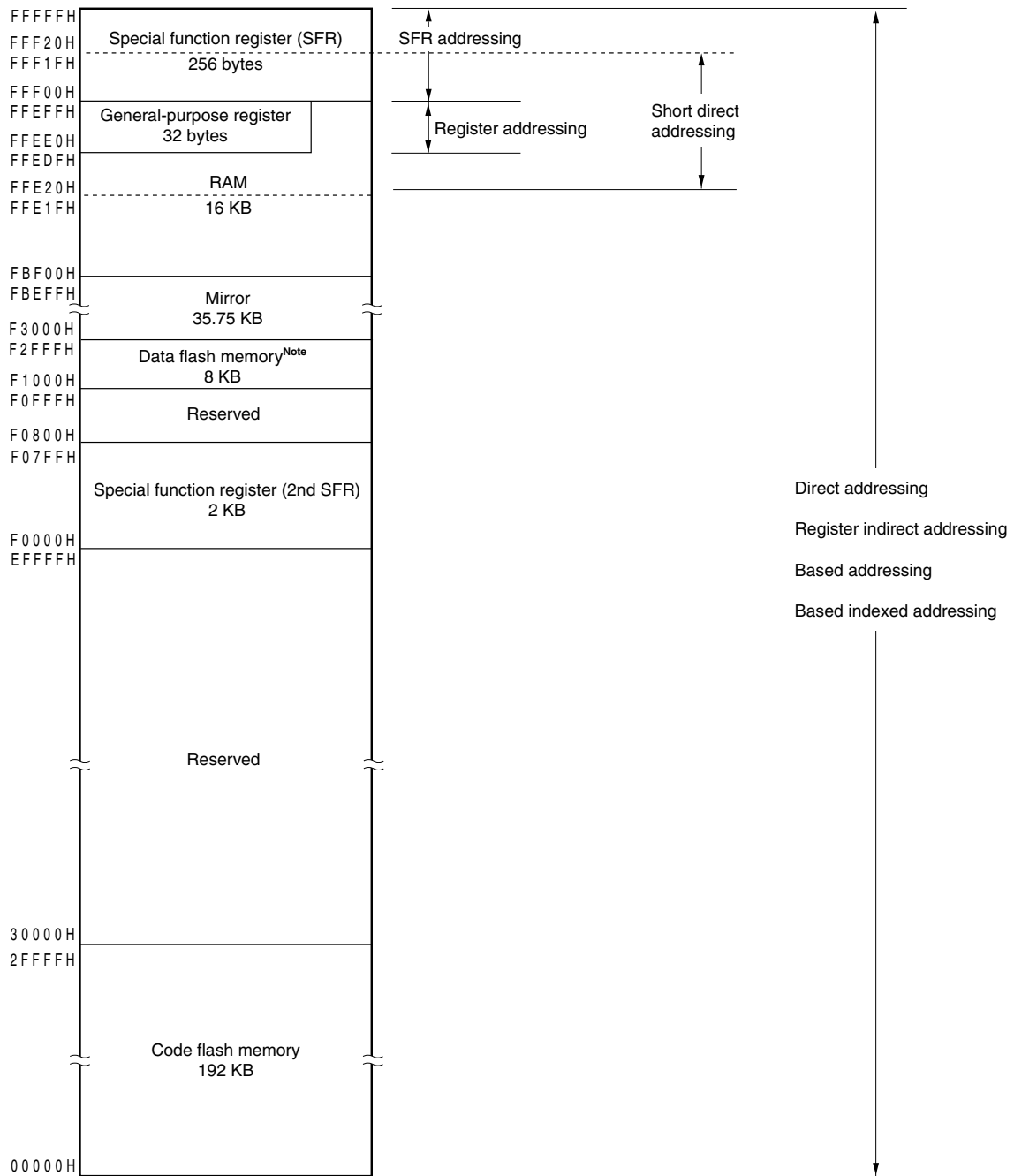
**Figure 3-17. Correspondence Between Data Memory and Addressing  
(R5F100xG, R5F101xG (x = A to C, E to G, J, L, M, P))**



**Note** R5F100xG only.

**Caution** When executing instructions from the RAM area while RAM parity error resets are enabled (RPERDIS = 1), be sure to initialize the used RAM area + 10 bytes.

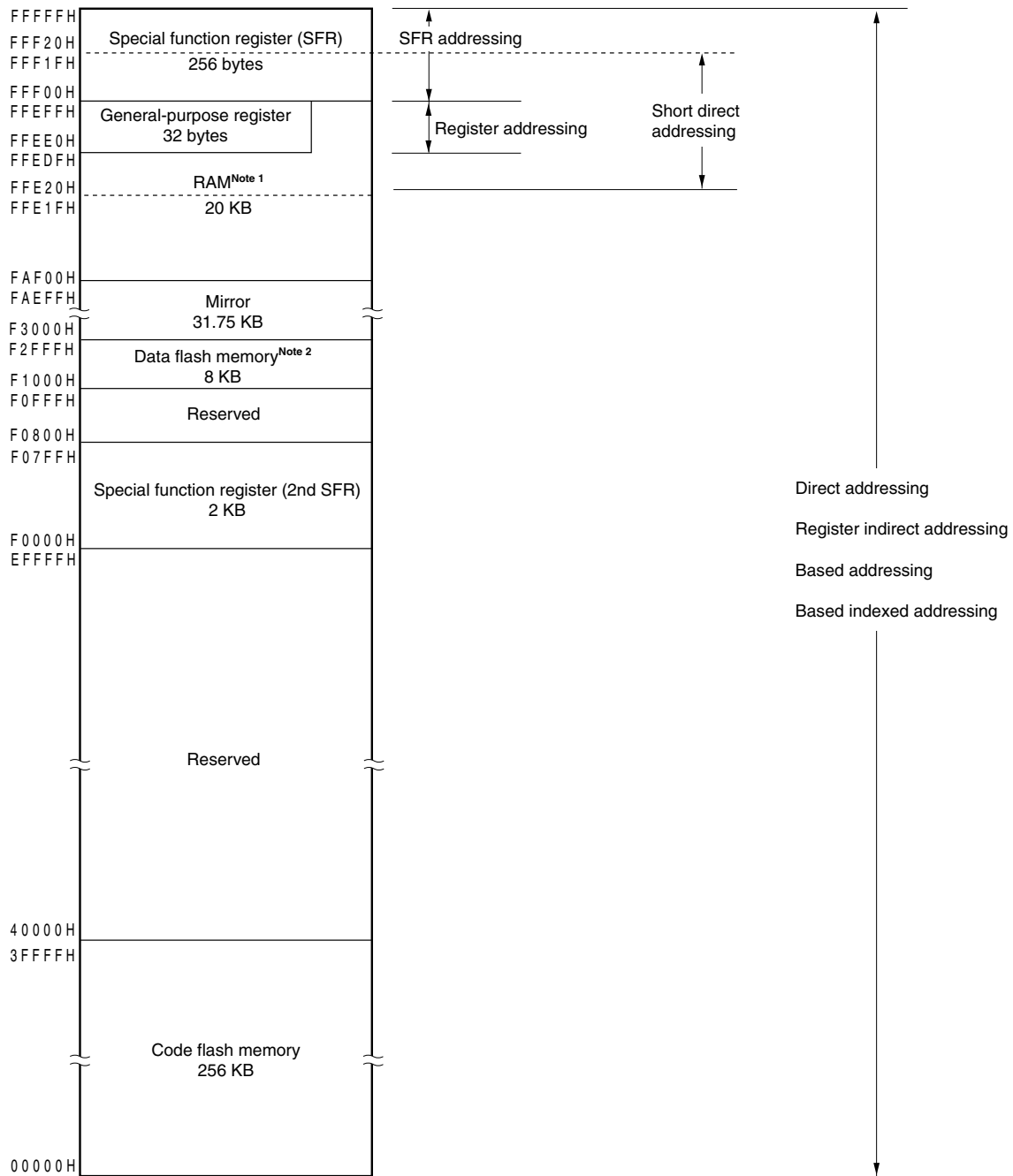
**Figure 3-18. Correspondence Between Data Memory and Addressing  
(R5F100xH, R5F101xH (x = E to G, J, L, M, P, S))**



**Note** R5F100xH only.

**Caution** When executing instructions from the RAM area while RAM parity error resets are enabled (RPERDIS = 1), be sure to initialize the used RAM area + 10 bytes.

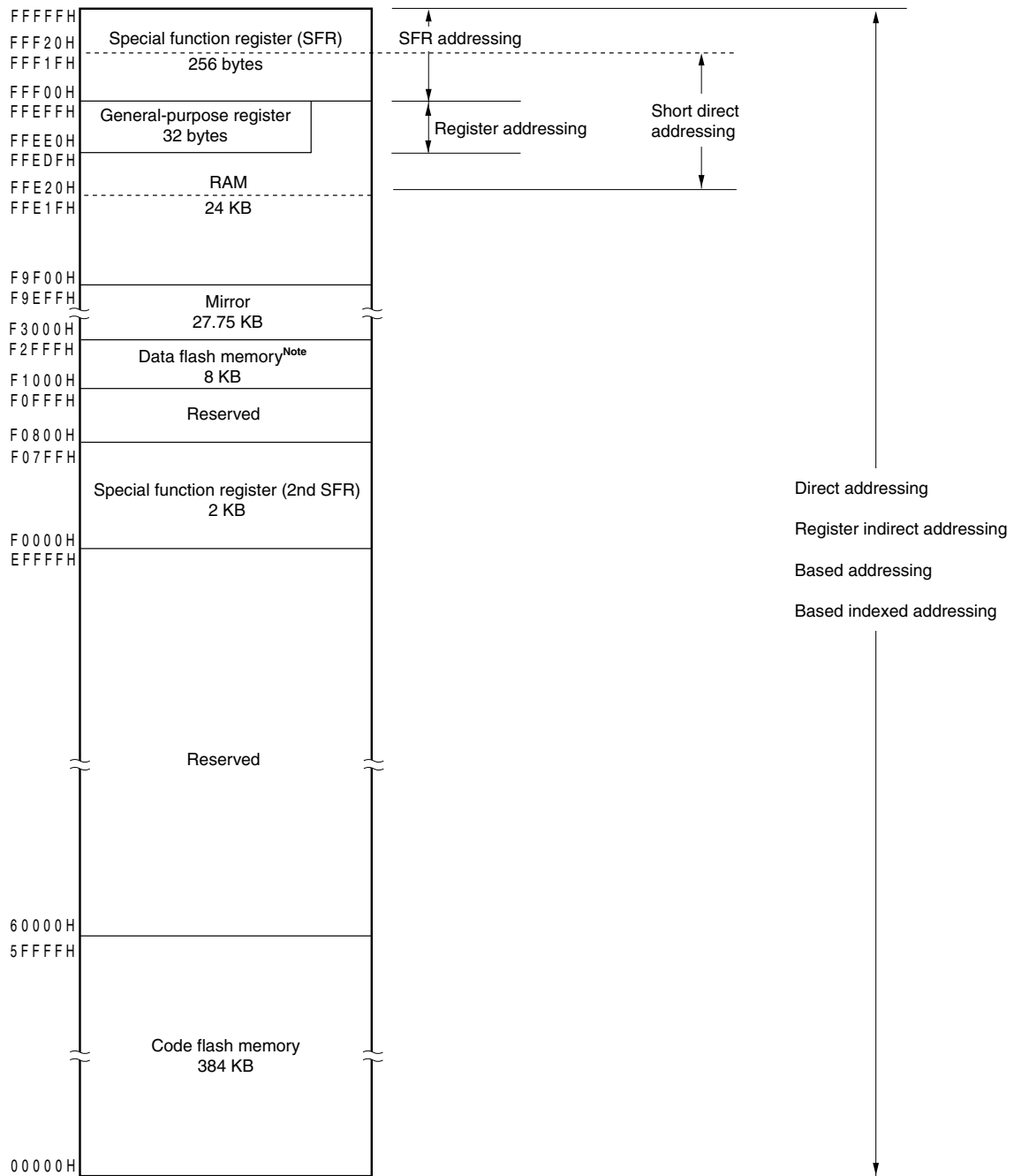
**Figure 3-19. Correspondence Between Data Memory and Addressing  
(R5F100xJ, R5F101xJ (x = F, G, J, L, M, P, S))**



- <R> **Notes 1.** Use of the area FAF00H to FB309H is prohibited when using the self-programming function and data flash function, because this area is used for self-programming library (R5F100xJ, R5F101xJ (x = F, G, J, L, M, P) only).
- 2.** R5F100xJ only.

**Caution** When executing instructions from the RAM area while RAM parity error resets are enabled (RPERDIS = 1), be sure to initialize the used RAM area + 10 bytes.

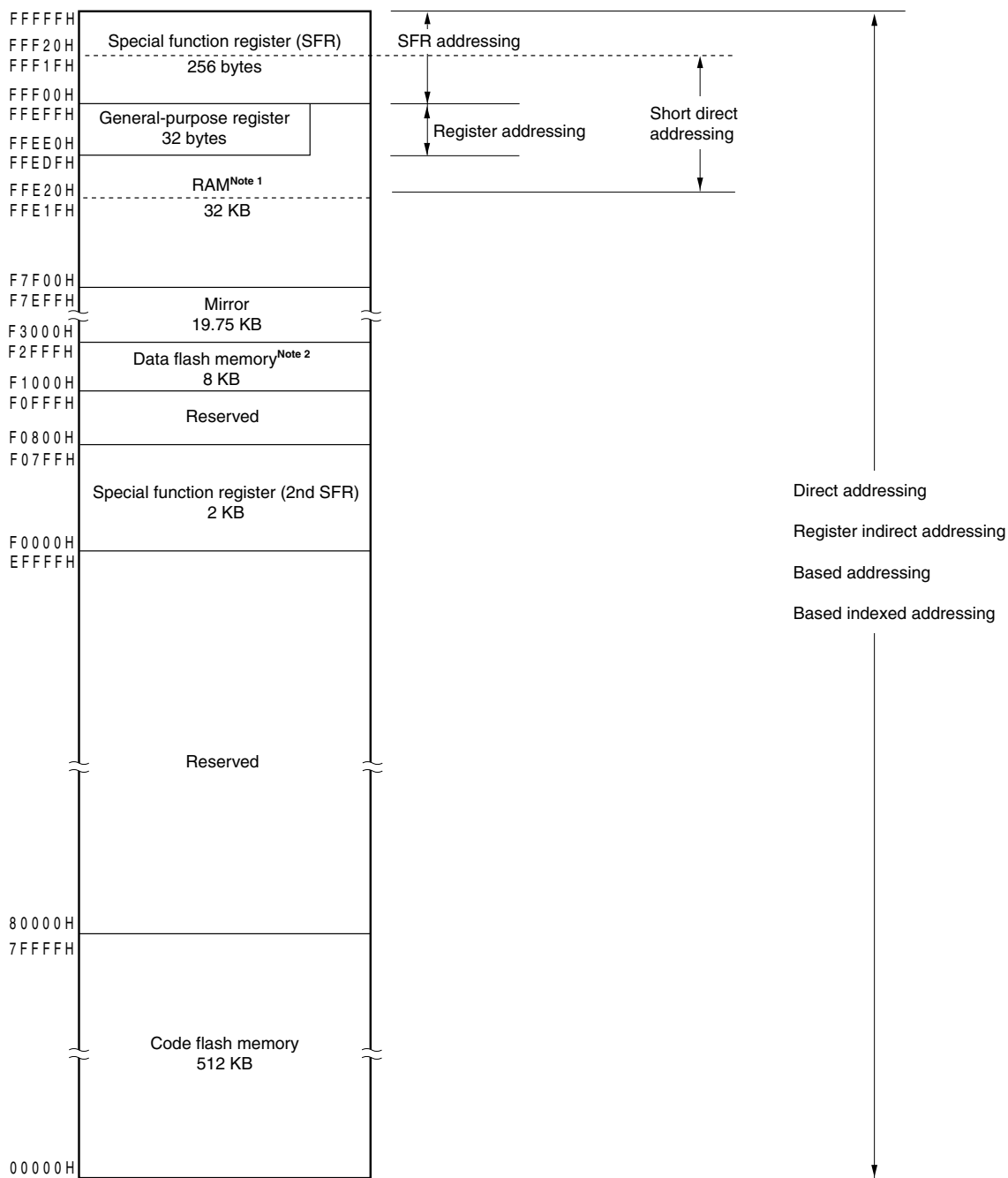
**Figure 3-20. Correspondence Between Data Memory and Addressing  
(R5F100xK, R5F101xK (x = F, G, J, L, M, P, S))**



**Note** R5F100xK only.

**Caution** When executing instructions from the RAM area while RAM parity error resets are enabled (RPERDIS = 1), be sure to initialize the used RAM area + 10 bytes.

**Figure 3-21. Correspondence Between Data Memory and Addressing  
(R5F100xL, R5F101xL (x = F, G, J, L, M, P, S))**



- <R> **Notes 1.** Use of the area F7F00H to F8309H is prohibited when using the self-programming function and data flash function, because this area is used for self-programming library.
- 2.** R5F100xL only.

**Caution** When executing instructions from the RAM area while RAM parity error resets are enabled (RPERDIS = 1), be sure to initialize the used RAM area + 10 bytes.

### 3.2 Processor Registers

The RL78/G13 products incorporate the following processor registers.

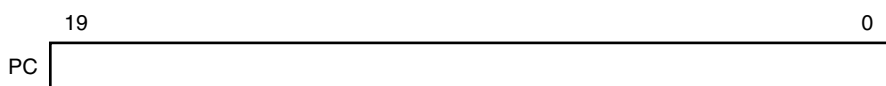
#### 3.2.1 Control registers

The control registers control the program sequence, statuses and stack memory. The control registers consist of a program counter (PC), a program status word (PSW) and a stack pointer (SP).

##### (1) Program counter (PC)

The program counter is a 20-bit register that holds the address information of the next program to be executed. In normal operation, PC is automatically incremented according to the number of bytes of the instruction to be fetched. When a branch instruction is executed, immediate data and register contents are set. Reset signal generation sets the reset vector table values at addresses 0000H and 0001H to the program counter.

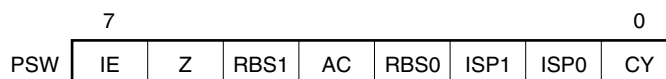
Figure 3-22. Format of Program Counter



##### (2) Program status word (PSW)

The program status word is an 8-bit register consisting of various flags set/reset by instruction execution. Program status word contents are stored in the stack area upon vectored interrupt request is acknowledged or PUSH PSW instruction execution and are restored upon execution of the RETB, RETI and POP PSW instructions. Reset signal generation sets the PSW register to 06H.

Figure 3-23. Format of Program Status Word



##### (a) Interrupt enable flag (IE)

This flag controls the interrupt request acknowledge operations of the CPU. When 0, the IE flag is set to the interrupt disabled (DI) state, and all maskable interrupt requests are disabled. When 1, the IE flag is set to the interrupt enabled (EI) state and interrupt request acknowledgment is controlled with an in-service priority flag (ISP1, ISP0), an interrupt mask flag for various interrupt sources, and a priority specification flag. The IE flag is reset (0) upon DI instruction execution or interrupt acknowledgment and is set (1) upon EI instruction execution.

##### (b) Zero flag (Z)

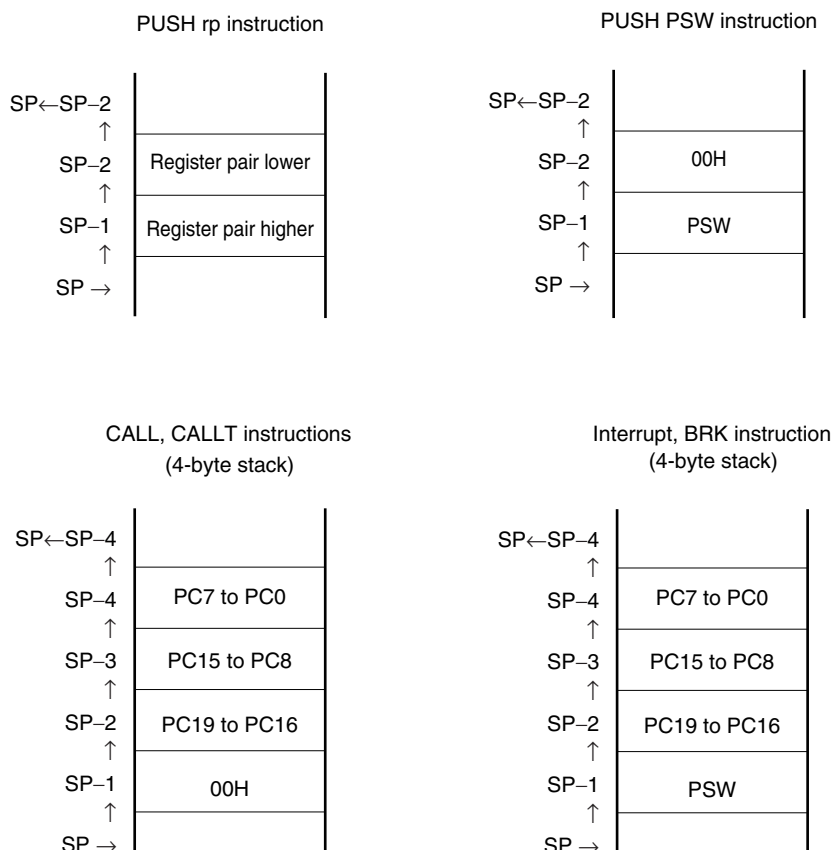
When the operation result is zero, this flag is set (1). It is reset (0) in all other cases.

##### (c) Register bank select flags (RBS0, RBS1)

These are 2-bit flags to select one of the four register banks. In these flags, the 2-bit information that indicates the register bank selected by SEL RBn instruction execution is stored.



**Figure 3-25. Data to Be Saved to Stack Memory**



### 3.2.2 General-purpose registers

General-purpose registers are mapped at particular addresses (FFEE0H to FFEFFH) of the data memory. The general-purpose registers consists of 4 banks, each bank consisting of eight 8-bit registers (X, A, C, B, E, D, L, and H).

Each register can be used as an 8-bit register, and two 8-bit registers can also be used in a pair as a 16-bit register (AX, BC, DE, and HL).

These registers can be described in terms of function names (X, A, C, B, E, D, L, H, AX, BC, DE, and HL) and absolute names (R0 to R7 and RP0 to RP3).

Register banks to be used for instruction execution are set by the CPU control instruction (SEL RBn). Because of the 4-register bank configuration, an efficient program can be created by switching between a register for normal processing and a register for interrupts for each bank.

**Cautions 1. It is prohibited to use the general-purpose register (FFEE0H to FFEFFH) space for fetching instructions or as a stack area.**

<R>

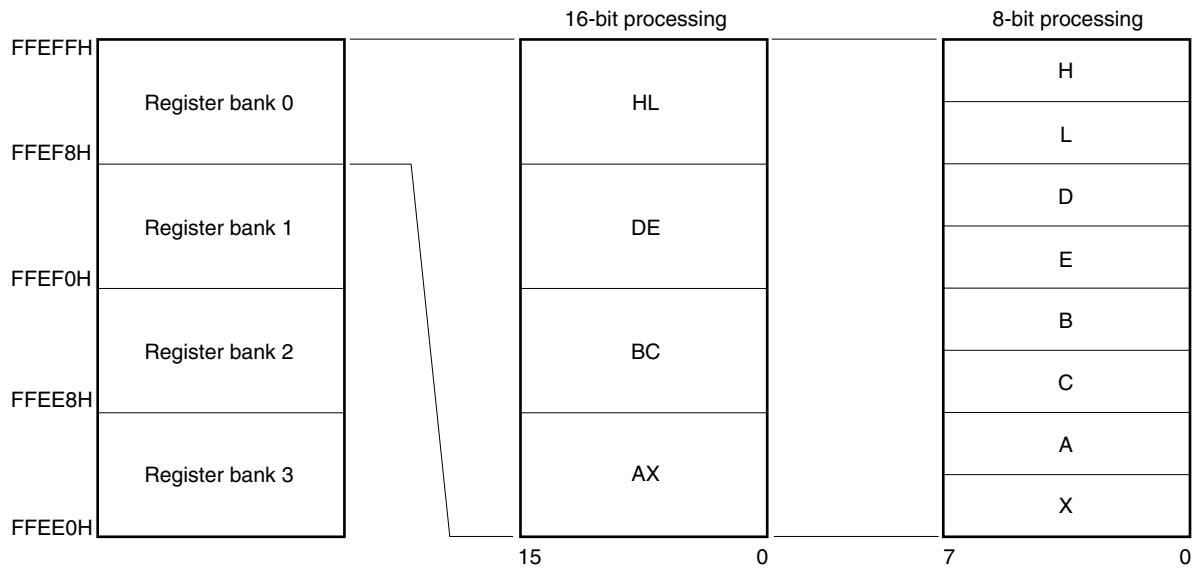
**2. The internal RAM in the following products cannot be used as stack memory when using the self-programming function and data flash function.**

- R5F100xD, R5F101xD (x = 6 to 8, A to C, E to G, J, L): FF300H to FF309H
- R5F100xE, R5F101xE (x = 6 to 8, A to C, E to G, J, L): FEF00H to FF309H
- R5F100xJ, R5F101xJ (x = F, G, J, L, M, P): FAF00H to FB309H
- R5F100xL, R5F101xL (x = F, G, J, L, M, P, S): F7F00H to F8309H

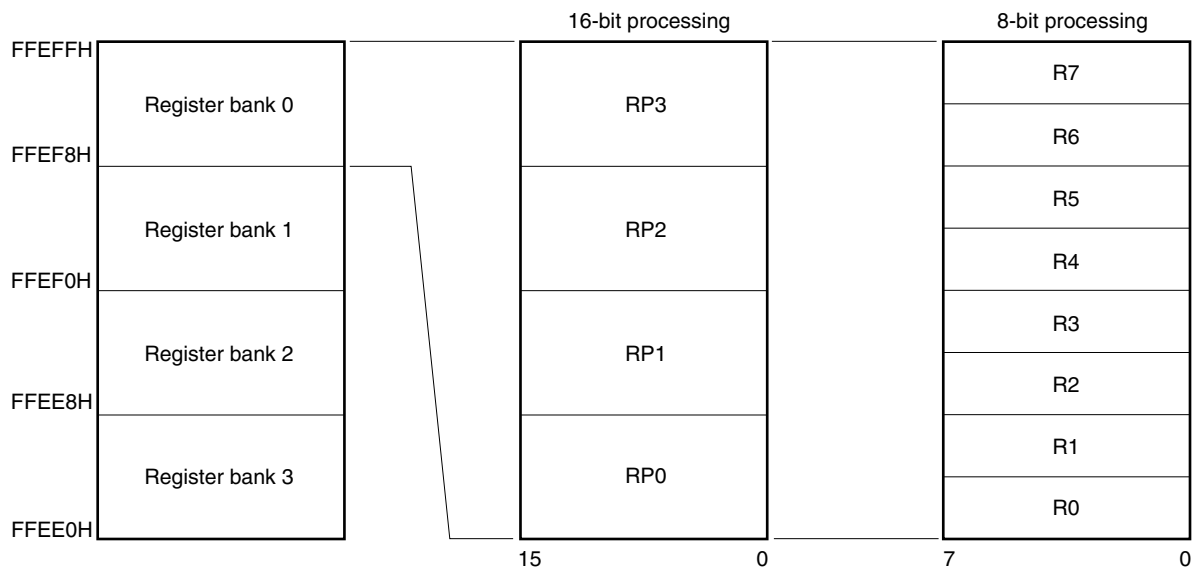


Figure 3-26. Configuration of General-Purpose Registers

(a) Function name



(b) Absolute name



### 3.2.3 ES and CS registers

The ES register is used for data access and the CS register is used to specify the higher address when a branch instruction is executed.

The default value of the ES register after reset is 0FH, and that of the CS register is 00H.

**Figure 3-27. Configuration of ES and CS Registers**

	7	6	5	4	3	2	1	0
ES	0	0	0	0	ES3	ES2	ES1	ES0
CS	0	0	0	0	CS3	CP2	CP1	CP0

### 3.2.4 Special function registers (SFRs)

Unlike a general-purpose register, each SFR has a special function.

SFRs are allocated to the FFF00H to FFFFFH area.

SFRs can be manipulated like general-purpose registers, using operation, transfer, and bit manipulation instructions. The manipulable bit units, 1, 8, and 16, depend on the SFR type.

Each manipulation bit unit can be specified as follows.

- 1-bit manipulation  
Describe the symbol reserved by the assembler for the 1-bit manipulation instruction operand (sfr.bit). This manipulation can also be specified with an address.
- 8-bit manipulation  
Describe the symbol reserved by the assembler for the 8-bit manipulation instruction operand (sfr). This manipulation can also be specified with an address.
- 16-bit manipulation  
Describe the symbol reserved by the assembler for the 16-bit manipulation instruction operand (sfrp). When specifying an address, describe an even address.

Table 3-5 gives a list of the SFRs. The meanings of items in the table are as follows.

- Symbol  
Symbol indicating the address of a special function register. It is a reserved word in the assembler, and is defined as an sfr variable using the #pragma sfr directive in the compiler. When using the assembler, debugger, and simulator, symbols can be written as an instruction operand.
- R/W  
Indicates whether the corresponding SFR can be read or written.  
R/W: Read/write enable  
R: Read only  
W: Write only
- Manipulable bit units  
“√” indicates the manipulable bit unit (1, 8, or 16). “–” indicates a bit unit for which manipulation is not possible.
- After reset  
Indicates each register status upon reset signal generation.

**Caution** Do not access addresses to which extended SFRs are not assigned.

**Remark** For extended SFRs (2nd SFRs), see 3.2.5 Extended special function registers (2nd SFRs: 2nd Special Function Registers).

Table 3-5. SFR List (1/5)

Address	Special Function Register (SFR) Name	Symbol		R/W	Manipulable Bit Range			After Reset
					1-bit	8-bit	16-bit	
FFF00H	Port register 0	P0		R/W	√	√	–	00H
FFF01H	Port register 1	P1		R/W	√	√	–	00H
FFF02H	Port register 2	P2		R/W	√	√	–	00H
FFF03H	Port register 3	P3		R/W	√	√	–	00H
FFF04H	Port register 4	P4		R/W	√	√	–	00H
FFF05H	Port register 5	P5		R/W	√	√	–	00H
FFF06H	Port register 6	P6		R/W	√	√	–	00H
FFF07H	Port register 7	P7		R/W	√	√	–	00H
FFF08H	Port register 8	P8		R/W	√	√	–	00H
FFF09H	Port register 9	P9		R/W	√	√	–	00H
FFF0AH	Port register 10	P10		R/W	√	√	–	00H
FFF0BH	Port register 11	P11		R/W	√	√	–	00H
FFF0CH	Port register 12	P12		R/W	√	√	–	Undefined
FFF0DH	Port register 13	P13		R/W	√	√	–	Undefined
FFF0EH	Port register 14	P14		R/W	√	√	–	00H
FFF0FH	Port register 15	P15		R/W	√	√	–	00H
FFF10H	Serial data register 00	TXD0/ SIO00	SDR00	R/W	–	√	√	0000H
FFF11H		–			–	–		
FFF12H	Serial data register 01	RXD0/ SIO01	SDR01	R/W	–	√	√	0000H
FFF13H		–			–	–		
FFF14H	Serial data register 12	TXD3/ SIO30	SDR12	R/W	–	√	√	0000H
FFF15H		–			–	–		
FFF16H	Serial data register 13	RXD3/ SIO31	SDR13	R/W	–	√	√	0000H
FFF17H		–			–	–		
FFF18H	Timer data register 00	TDR00		R/W	–	–	√	0000H
FFF19H					–	–	–	
FFF1AH	Timer data register 01	TDR01L	TDR01	R/W	–	√	√	00H
FFF1BH		TDR01H			–	√	00H	
FFF1EH	10-bit A/D conversion result register	ADCR		R	–	–	√	0000H
FFF1FH	8-bit A/D conversion result register	ADCRH		R	–	√	–	00H
FFF20H	Port mode register 0	PM0		R/W	√	√	–	FFH
FFF21H	Port mode register 1	PM1		R/W	√	√	–	FFH
FFF22H	Port mode register 2	PM2		R/W	√	√	–	FFH
FFF23H	Port mode register 3	PM3		R/W	√	√	–	FFH
FFF24H	Port mode register 4	PM4		R/W	√	√	–	FFH
FFF25H	Port mode register 5	PM5		R/W	√	√	–	FFH
FFF26H	Port mode register 6	PM6		R/W	√	√	–	FFH
FFF27H	Port mode register 7	PM7		R/W	√	√	–	FFH
FFF28H	Port mode register 8	PM8		R/W	√	√	–	FFH
FFF29H	Port mode register 9	PM9		R/W	√	√	–	FFH

Table 3-5. SFR List (2/5)

Address	Special Function Register (SFR) Name	Symbol		R/W	Manipulable Bit Range			After Reset
					1-bit	8-bit	16-bit	
FFF2AH	Port mode register 10	PM10		R/W	√	√	–	FFH
FFF2BH	Port mode register 11	PM11		R/W	√	√	–	FFH
FFF2CH	Port mode register 12	PM12		R/W	√	√	–	FFH
FFF2EH	Port mode register 14	PM14		R/W	√	√	–	FFH
FFF2FH	Port mode register 15	PM15		R/W	√	√	–	FFH
FFF30H	A/D converter mode register 0	ADM0		R/W	√	√	–	00H
FFF31H	Analog input channel specification register	ADS		R/W	√	√	–	00H
FFF32H	A/D converter mode register 1	ADM1		R/W	√	√	–	00H
FFF37H	Key return mode register	KRM		R/W	√	√	–	00H
FFF38H	External interrupt rising edge enable register 0	EGP0		R/W	√	√	–	00H
FFF39H	External interrupt falling edge enable register 0	EGN0		R/W	√	√	–	00H
FFF3AH	External interrupt rising edge enable register 1	EGP1		R/W	√	√	–	00H
FFF3BH	External interrupt falling edge enable register 1	EGN1		R/W	√	√	–	00H
FFF44H	Serial data register 02	TXD1/ SIO10	SDR02	R/W	–	√	√	0000H
FFF45H		–			–	–		
FFF46H	Serial data register 03	RXD1/ SIO11	SDR03	R/W	–	√	√	0000H
FFF47H		–			–	–		
FFF48H	Serial data register 10	TXD2/ SIO20	SDR10	R/W	–	√	√	0000H
FFF49H		–			–	–		
FFF4AH	Serial data register 11	RXD2/ SIO21	SDR11	R/W	–	√	√	0000H
FFF4BH		–			–	–		
FFF50H	IICA shift register 0	IICA0		R/W	–	√	–	00H
FFF51H	IICA status register 0	IICS0		R	√	√	–	00H
FFF52H	IICA flag register 0	IICF0		R/W	√	√	–	00H
FFF54H	IICA shift register 1	IICA1		R/W	–	√	–	00H
FFF55H	IICA status register 1	IICS1		R	√	√	–	00H
FFF56H	IICA flag register 1	IICF1		R/W	√	√	–	00H
FFF64H	Timer data register 02	TDR02		R/W	–	–	√	0000H
FFF65H								
FFF66H	Timer data register 03	TDR03L	TDR03	R/W	–	√	√	00H
FFF67H		TDR03H			–	√		
FFF68H	Timer data register 04	TDR04		R/W	–	–	√	0000H
FFF69H								

Table 3-5. SFR List (3/5)

Address	Special Function Register (SFR) Name	Symbol		R/W	Manipulable Bit Range			After Reset
					1-bit	8-bit	16-bit	
FFF6AH	Timer data register 05	TDR05		R/W	–	–	√	0000H
FFF6BH								
FFF6CH	Timer data register 06	TDR06		R/W	–	–	√	0000H
FFF6DH								
FFF6EH	Timer data register 07	TDR07		R/W	–	–	√	0000H
FFF6FH								
FFF70H	Timer data register 10	TDR10		R/W	–	–	√	0000H
FFF71H								
FFF72H	Timer data register 11	TDR11L	TDR11	R/W	–	√	√	00H
FFF73H		TDR11H			–	√		00H
FFF74H	Timer data register 12	TDR12		R/W	–	–	√	0000H
FFF75H								
FFF76H	Timer data register 13	TDR13L	TDR13	R/W	–	√	√	00H
FFF77H		TDR13H			–	√		00H
FFF78H	Timer data register 14	TDR14		R/W	–	–	√	0000H
FFF79H								
FFF7AH	Timer data register 15	TDR15		R/W	–	–	√	0000H
FFF7BH								
FFF7CH	Timer data register 16	TDR16		R/W	–	–	√	0000H
FFF7DH								
FFF7EH	Timer data register 17	TDR17		R/W	–	–	√	0000H
FFF7FH								
FFF90H	Interval timer control register	ITMC		R/W	–	–	√	0FFFH
FFF91H								
FFF92H	Second count register	SEC		R/W	–	√	–	00H
FFF93H	Minute count register	MIN		R/W	–	√	–	00H
FFF94H	Hour count register	HOUR		R/W	–	√	–	12H <sup>Note</sup>
FFF95H	Week count register	WEEK		R/W	–	√	–	00H
FFF96H	Day count register	DAY		R/W	–	√	–	01H
FFF97H	Month count register	MONTH		R/W	–	√	–	01H
FFF98H	Year count register	YEAR		R/W	–	√	–	00H
FFF99H	Watch error correction register	SUBCUD		R/W	–	√	–	00H
FFF9AH	Alarm minute register	ALARMWMM		R/W	–	√	–	00H
FFF9BH	Alarm hour register	ALARMWHH		R/W	–	√	–	12H
FFF9CH	Alarm week register	ALARMWW		R/W	–	√	–	00H
FFF9DH	Real-time clock control register 0	RTCC0		R/W	√	√	–	00H
FFF9EH	Real-time clock control register 1	RTCC1		R/W	√	√	–	00H

**Note** The value of this register is 00H if the AMPM bit (bit 3 of real-time clock control register 0 (RTCC0)) is set to 1 after reset.

Table 3-5. SFR List (4/5)

Address	Special Function Register (SFR) Name	Symbol	R/W	Manipulable Bit Range			After Reset
				1-bit	8-bit	16-bit	
FFFA0H	Clock operation mode control register	CMC	R/W	–	√	–	00H
FFFA1H	Clock operation status control register	CSC	R/W	√	√	–	C0H
FFFA2H	Oscillation stabilization time counter status register	OSTC	R	√	√	–	00H
FFFA3H	Oscillation stabilization time select register	OSTS	R/W	–	√	–	07H
FFFA4H	System clock control register	CKC	R/W	√	√	–	00H
FFFA5H	Clock output select register 0	CKS0	R/W	√	√	–	00H
FFFA6H	Clock output select register 1	CKS1	R/W	√	√	–	00H
FFFA8H	Reset control flag register	RESF	R	–	√	–	Undefined <sup>Note 1</sup>
FFFA9H	Voltage detection register	LVIM	R/W	√	√	–	00H <sup>Note 2</sup>
FFFAAH	Voltage detection level register	LVIS	R/W	√	√	–	00H/01H/81H <sup>Note 3</sup>
FFFABH	Watchdog timer enable register	WDTE	R/W	–	√	–	1AH/9AH <sup>Note 4</sup>
FFFACH	CRC input register	CRCIN	R/W	–	√	–	00H
FFFB0H	DMA SFR address register 0	DSA0	R/W	–	√	–	00H
FFFB1H	DMA SFR address register 1	DSA1	R/W	–	√	–	00H
FFFB2H	DMA RAM address register 0L	DRA0L	DRA0	R/W	–	√	00H
FFFB3H	DMA RAM address register 0H	DRA0H		R/W	–	√	
FFFB4H	DMA RAM address register 1L	DRA1L	DRA1	R/W	–	√	00H
FFFB5H	DMA RAM address register 1H	DRA1H		R/W	–	√	
FFFB6H	DMA byte count register 0L	DBC0L	DBC0	R/W	–	√	00H
FFFB7H	DMA byte count register 0H	DBC0H		R/W	–	√	
FFFB8H	DMA byte count register 1L	DBC1L	DBC1	R/W	–	√	00H
FFFB9H	DMA byte count register 1H	DBC1H		R/W	–	√	
FFFBAAH	DMA mode control register 0	DMC0	R/W	√	√	–	00H
FFFBABH	DMA mode control register 1	DMC1	R/W	√	√	–	00H
FFFBACH	DMA operation control register 0	DRC0	R/W	√	√	–	00H
FFFBADH	DMA operation control register 1	DRC1	R/W	√	√	–	00H
FFFD0H	Interrupt request flag register 2L	IF2L	IF2	R/W	√	√	00H
FFFD1H	Interrupt request flag register 2H	IF2H		R/W	√	√	
FFFD2H	Interrupt request flag register 3L	IF3L	IF3	R/W	√	√	00H
FFFD4H	Interrupt mask flag register 2L	MK2L	MK2	R/W	√	√	FFH
FFFD5H	Interrupt mask flag register 2H	MK2H		R/W	√	√	
FFFD6H	Interrupt mask flag register 3L	MK3L	MK3	R/W	√	√	FFH

- Notes**
1. The reset value of the RESF register varies depending on the reset source.
  2. The reset value of the LVIM register varies depending on the reset source.
  3. The reset value of the LVIS register varies depending on the reset source and the setting of the option byte.
  4. The reset value of the WDTE register is determined by the setting of the option byte.

Table 3-5. SFR List (5/5)

Address	Special Function Register (SFR) Name	Symbol		R/W	Manipulable Bit Range			After Reset
					1-bit	8-bit	16-bit	
FFFD8H	Priority specification flag register 02L	PR02L	PR02	R/W	√	√	√	FFH
FFFD9H	Priority specification flag register 02H	PR02H		R/W	√	√		FFH
FFFDAH	Priority specification flag register 02L	PR03L	PR03	R/W	√	√	√	FFH
FFFDCH	Priority specification flag register 12L	PR12L	PR12	R/W	√	√	√	FFH
FFDDH	Priority specification flag register 12H	PR12H		R/W	√	√		FFH
FFFDEH	Priority specification flag register 13L	PR13L	PR13	R/W	√	√	√	FFH
FFFE0H	Interrupt request flag register 0L	IF0L	IF0	R/W	√	√	√	00H
FFFE1H	Interrupt request flag register 0H	IF0H		R/W	√	√		00H
FFFE2H	Interrupt request flag register 1L	IF1L	IF1	R/W	√	√	√	00H
FFFE3H	Interrupt request flag register 1H	IF1H		R/W	√	√		00H
FFFE4H	Interrupt mask flag register 0L	MK0L	MK0	R/W	√	√	√	FFH
FFFE5H	Interrupt mask flag register 0H	MK0H		R/W	√	√		FFH
FFFE6H	Interrupt mask flag register 1L	MK1L	MK1	R/W	√	√	√	FFH
FFFE7H	Interrupt mask flag register 1H	MK1H		R/W	√	√		FFH
FFFE8H	Priority specification flag register 00L	PR00L	PR00	R/W	√	√	√	FFH
FFFE9H	Priority specification flag register 00H	PR00H		R/W	√	√		FFH
FFFEAH	Priority specification flag register 01L	PR01L	PR01	R/W	√	√	√	FFH
FFFEBH	Priority specification flag register 01H	PR01H		R/W	√	√		FFH
FFFECH	Priority specification flag register 10L	PR10L	PR10	R/W	√	√	√	FFH
FF FEDH	Priority specification flag register 10H	PR10H		R/W	√	√		FFH
FFFE EH	Priority specification flag register 11L	PR11L	PR11	R/W	√	√	√	FFH
FFFE FH	Priority specification flag register 11H	PR11H		R/W	√	√		FFH
FFFF0H	Multiplication/division data register A (L)	MDAL		R/W	-	-	√	0000H
FFFF1H								
FFFF2H	Multiplication/division data register A (H)	MDAH		R/W	-	-	√	0000H
FFFF3H								
FFFF4H	Multiplication/division data register B (H)	MDBH		R/W	-	-	√	0000H
FFFF5H								
FFFF6H	Multiplication/division data register B (L)	MDBL		R/W	-	-	√	0000H
FFFF7H								
FFFFEH	Processor mode control register	PMC		R/W	√	√	-	00H

**Remark** For extended SFRs (2<sup>nd</sup> SFRs), see **Table 3-6 Extended SFR (2<sup>nd</sup> SFR) List**.



### 3.2.5 Extended special function registers (2nd SFRs: 2nd Special Function Registers)

Unlike a general-purpose register, each extended SFR (2<sup>nd</sup> SFR) has a special function.

Extended SFRs are allocated to the F0000H to F07FFH area. SFRs other than those in the SFR area (FFF00H to FFFFFH) are allocated to this area. An instruction that accesses the extended SFR area, however, is 1 byte longer than an instruction that accesses the SFR area.

Extended SFRs can be manipulated like general-purpose registers, using operation, transfer, and bit manipulation instructions. The manipulable bit units, 1, 8, and 16, depend on the SFR type.

Each manipulation bit unit can be specified as follows.

- 1-bit manipulation  
Describe the symbol reserved by the assembler for the 1-bit manipulation instruction operand (!addr16.bit). This manipulation can also be specified with an address.
- 8-bit manipulation  
Describe the symbol reserved by the assembler for the 8-bit manipulation instruction operand (!addr16). This manipulation can also be specified with an address.
- 16-bit manipulation  
Describe the symbol reserved by the assembler for the 16-bit manipulation instruction operand (!addr16). When specifying an address, describe an even address.

Table 3-6 gives a list of the extended SFRs. The meanings of items in the table are as follows.

- Symbol  
Symbol indicating the address of an extended SFR. It is a reserved word in the assembler, and is defined as an sfr variable using the #pragma sfr directive in the compiler. When using the assembler, debugger, and simulator, symbols can be written as an instruction operand.
- R/W  
Indicates whether the corresponding extended SFR can be read or written.  
R/W: Read/write enable  
R: Read only  
W: Write only
- Manipulable bit units  
“√” indicates the manipulable bit unit (1, 8, or 16). “–” indicates a bit unit for which manipulation is not possible.
- After reset  
Indicates each register status upon reset signal generation.

**Caution** Do not access addresses to which extended SFRs are not assigned.

**Remark** For SFRs in the SFR area, see 3.2.4 Special function registers (SFRs).

Table 3-6. Extended SFR (2<sup>nd</sup> SFR) List (1/8)

Address	Special Function Register (SFR) Name	Symbol	R/W	Manipulable Bit Range			After Reset
				1-bit	8-bit	16-bit	
F0010H	A/D converter mode register 2	ADM2	R/W	√	√	–	00H
F0011H	Conversion result comparison upper limit setting register	ADUL	R/W	–	√	–	FFH
F0012H	Conversion result comparison lower limit setting register	ADLL	R/W	–	√	–	00H
F0013H	A/D test register	ADTES	R/W	–	√	–	00H
F0030H	Pull-up resistor option register 0	PU0	R/W	√	√	–	00H
F0031H	Pull-up resistor option register 1	PU1	R/W	√	√	–	00H
F0033H	Pull-up resistor option register 3	PU3	R/W	√	√	–	00H
F0034H	Pull-up resistor option register 4	PU4	R/W	√	√	–	01H
F0035H	Pull-up resistor option register 5	PU5	R/W	√	√	–	00H
F0036H	Pull-up resistor option register 6	PU6	R/W	√	√	–	00H
F0037H	Pull-up resistor option register 7	PU7	R/W	√	√	–	00H
F0038H	Pull-up resistor option register 8	PU8	R/W	√	√	–	00H
F0039H	Pull-up resistor option register 9	PU9	R/W	√	√	–	00H
F003AH	Pull-up resistor option register 10	PU10	R/W	√	√	–	00H
F003BH	Pull-up resistor option register 11	PU11	R/W	√	√	–	00H
F003CH	Pull-up resistor option register 12	PU12	R/W	√	√	–	00H
F003EH	Pull-up resistor option register 14	PU14	R/W	√	√	–	00H
F0040H	Port input mode register 0	PIM0	R/W	√	√	–	00H
F0041H	Port input mode register 1	PIM1	R/W	√	√	–	00H
F0044H	Port input mode register 4	PIM4	R/W	√	√	–	00H
F0045H	Port input mode register 5	PIM5	R/W	√	√	–	00H
F0048H	Port input mode register 8	PIM8	R/W	√	√	–	00H
F004EH	Port input mode register 14	PIM14	R/W	√	√	–	00H
F0050H	Port output mode register 0	POM0	R/W	√	√	–	00H
F0051H	Port output mode register 1	POM1	R/W	√	√	–	00H
F0054H	Port output mode register 4	POM4	R/W	√	√	–	00H
F0055H	Port output mode register 5	POM5	R/W	√	√	–	00H
F0057H	Port output mode register 7	POM7	R/W	√	√	–	00H
F0058H	Port output mode register 8	POM8	R/W	√	√	–	00H
F0059H	Port output mode register 9	POM9	R/W	√	√	–	00H
F005EH	Port output mode register 14	POM14	R/W	√	√	–	00H
F0060H	Port mode control register 0	PMC0	R/W	√	√	–	FFH
F0063H	Port mode control register 3	PMC3	R/W	√	√	–	FFH
F006AH	Port mode control register 10	PMC10	R/W	√	√	–	FFH
F006BH	Port mode control register 11	PMC11	R/W	√	√	–	FFH
F006CH	Port mode control register 12	PMC12	R/W	√	√	–	FFH
F006EH	Port mode control register 14	PMC14	R/W	√	√	–	FFH

Table 3-6. Extended SFR (2nd SFR) List (2/8)

Address	Special Function Register (SFR) Name	Symbol		R/W	Manipulable Bit Range			After Reset
					1-bit	8-bit	16-bit	
F0070H	Noise filter enable register 0	NFEN0		R/W	√	√	–	00H
F0071H	Noise filter enable register 1	NFEN1		R/W	√	√	–	00H
F0072H	Noise filter enable register 2	NFEN2		R/W	√	√	–	00H
F0073H	Input switch control register	ISC		R/W	√	√	–	00H
F0074H	Timer input select register 0	TIS0		R/W	–	√	–	00H
F0076H	A/D port configuration register	ADPC		R/W	–	√	–	00H
F0077H	Peripheral I/O redirection register	PIOR		R/W	–	√	–	00H
F0078H	Invalid memory access detection control register	IAWCTL		R/W	–	√	–	00H
F007DH	Global digital input disable register	GDIDIS		R/W	√	√	–	00H
F0090H	Data flash control register	DFLCTL		R/W	√	√	–	00H
F00A0H	High-speed on-chip oscillator trimming register	HIOTRM		R/W	–	√	–	<b>Note</b>
F00A8H	High-speed on-chip oscillator frequency select register	HOCODIV		R/W	–	√	–	Undefined
F00E0H	Multiplication/division data register C (L)	MDCL		R/W	–	–	√	0000H
F00E2H	Multiplication/division data register C (H)	MDCH		R/W	–	–	√	0000H
F00E8H	Multiplication/division control register	MDUC		R/W	√	√	–	00H
F00F0H	Peripheral enable register 0	PER0		R/W	√	√	–	00H
F00F3H	Operation speed mode control register	OSMC		R/W	–	√	–	00H
F00F5H	RAM parity error control register	RPECTL		R/W	√	√	–	00H
F00FEH	BCD adjust result register	BCDADJ		R	–	√	–	Undefined
F0100H	Serial status register 00	SSR00L	SSR00	R	–	√	√	0000H
F0101H		–	–		–	–		
F0102H	Serial status register 01	SSR01L	SSR01	R	–	√	√	0000H
F0103H		–	–		–	–		
F0104H	Serial status register 02	SSR02L	SSR02	R	–	√	√	0000H
F0105H		–	–		–	–		
F0106H	Serial status register 03	SSR03L	SSR03	R	–	√	√	0000H
F0107H		–	–		–	–		
F0108H	Serial flag clear trigger register 00	SIR00L	SIR00	R/W	–	√	√	0000H
F0109H		–	–		–	–		
F010AH	Serial flag clear trigger register 01	SIR01L	SIR01	R/W	–	√	√	0000H
F010BH		–	–		–	–		
F010CH	Serial flag clear trigger register 02	SIR02L	SIR02	R/W	–	√	√	0000H
F010DH		–	–		–	–		
F010EH	Serial flag clear trigger register 03	SIR03L	SIR03	R/W	–	√	√	0000H
F010FH		–	–		–	–		

&lt;R&gt;

**Note** The reset value differs for each chip.

Table 3-6. Extended SFR (2nd SFR) List (3/8)

Address	Special Function Register (SFR) Name	Symbol		R/W	Manipulable Bit Range			After Reset
					1-bit	8-bit	16-bit	
F0110H	Serial mode register 00	SMR00		R/W	–	–	√	0020H
F0111H								
F0112H	Serial mode register 01	SMR01		R/W	–	–	√	0020H
F0113H								
F0114H	Serial mode register 02	SMR02		R/W	–	–	√	0020H
F0115H								
F0116H	Serial mode register 03	SMR03		R/W	–	–	√	0020H
F0117H								
F0118H	Serial communication operation setting register 00	SCR00		R/W	–	–	√	0087H
F0119H								
F011AH	Serial communication operation setting register 01	SCR01		R/W	–	–	√	0087H
F011BH								
F011CH	Serial communication operation setting register 02	SCR02		R/W	–	–	√	0087H
F011DH								
F011EH	Serial communication operation setting register 03	SCR03		R/W	–	–	√	0087H
F011FH								
F0120H	Serial channel enable status register 0	SE0L	SE0	R	√	√	√	0000H
F0121H		–			–			
F0122H	Serial channel start register 0	SS0L	SS0	R/W	√	√	√	0000H
F0123H		–			–			
F0124H	Serial channel stop register 0	ST0L	ST0	R/W	√	√	√	0000H
F0125H		–			–			
F0126H	Serial clock select register 0	SPS0L	SPS0	R/W	–	√	√	0000H
F0127H		–			–			
F0128H	Serial output register 0	SO0		R/W	–	–	√	0F0FH
F0129H								
F012AH	Serial output enable register 0	SOE0L	SOE0	R/W	√	√	√	0000H
F012BH		–			–			
F0134H	Serial output level register 0	SOL0L	SOL0	R/W	–	√	√	0000H
F0135H		–			–			
F0138H	Serial standby control register 0	SSC0L	SSC0	R/W	–	√	√	0000H
		–			–			
F0140H	Serial status register 10	SSR10L	SSR10	R	–	√	√	0000H
F0141H		–			–			
F0142H	Serial status register 11	SSR11L	SSR11	R	–	√	√	0000H
F0143H		–			–			
F0144H	Serial status register 12	SSR12L	SSR12	R	–	√	√	0000H
F0145H		–			–			
F0146H	Serial status register 13	SSR13L	SSR13	R	–	√	√	0000H
F0147H		–			–			

Table 3-6. Extended SFR (2nd SFR) List (4/8)

Address	Special Function Register (SFR) Name	Symbol		R/W	Manipulable Bit Range			After Reset
					1-bit	8-bit	16-bit	
F0148H	Serial flag clear trigger register 10	SIR10L	SIR10	R/W	–	√	√	0000H
F0149H		–			–			
F014AH	Serial flag clear trigger register 11	SIR11L	SIR11	R/W	–	√	√	0000H
F014BH		–			–			
F014CH	Serial flag clear trigger register 12	SIR12L	SIR12	R/W	–	√	√	0000H
F014DH		–			–			
F014EH	Serial flag clear trigger register 13	SIR13L	SIR13	R/W	–	√	√	0000H
F014FH		–			–			
F0150H	Serial mode register 10	SMR10		R/W	–	–	√	0020H
F0151H					–	–		
F0152H	Serial mode register 11	SMR11		R/W	–	–	√	0020H
F0153H					–	–		
F0154H	Serial mode register 12	SMR12		R/W	–	–	√	0020H
F0155H					–	–		
F0156H	Serial mode register 13	SMR13		R/W	–	–	√	0020H
F0157H					–	–		
F0158H	Serial communication operation setting register 10	SCR10		R/W	–	–	√	0087H
F0159H					–	–		
F015AH	Serial communication operation setting register 11	SCR11		R/W	–	–	√	0087H
F015BH					–	–		
F015CH	Serial communication operation setting register 12	SCR12		R/W	–	–	√	0087H
F015DH					–	–		
F015EH	Serial communication operation setting register 13	SCR13		R/W	–	–	√	0087H
F015FH					–	–		
F0160H	Serial channel enable status register 1	SE1L	SE1	R	√	√	√	0000H
F0161H		–			–			
F0162H	Serial channel start register 1	SS1L	SS1	R/W	√	√	√	0000H
F0163H		–			–			
F0164H	Serial channel stop register 1	ST1L	ST1	R/W	√	√	√	0000H
F0165H		–			–			
F0166H	Serial clock select register 1	SPS1L	SPS1	R/W	–	√	√	0000H
F0167H		–			–			
F0168H	Serial output register 1	SO1		R/W	–	–	√	0F0FH
F0169H					–	–		
F016AH	Serial output enable register 1	SOE1L	SOE1	R/W	√	√	√	0000H
F016BH		–			–			
F0174H	Serial output level register 1	SOL1L	SOL1	R/W	–	√	√	0000H
F0175H		–			–			
F0178H	Serial standby control register 1	SSC1L	SSC1	R/W	–	√	√	0000H
		–			–			

Table 3-6. Extended SFR (2nd SFR) List (5/8)

Address	Special Function Register (SFR) Name	Symbol	R/W	Manipulable Bit Range			After Reset
				1-bit	8-bit	16-bit	
F0180H	Timer counter register 00	TCR00	R	-	-	√	FFFFH
F0181H							
F0182H	Timer counter register 01	TCR01	R	-	-	√	FFFFH
F0183H							
F0184H	Timer counter register 02	TCR02	R	-	-	√	FFFFH
F0185H							
F0186H	Timer counter register 03	TCR03	R	-	-	√	FFFFH
F0187H							
F0188H	Timer counter register 04	TCR04	R	-	-	√	FFFFH
F0189H							
F018AH	Timer counter register 05	TCR05	R	-	-	√	FFFFH
F018BH							
F018CH	Timer counter register 06	TCR06	R	-	-	√	FFFFH
F018DH							
F018EH	Timer counter register 07	TCR07	R	-	-	√	FFFFH
F018FH							
F0190H	Timer mode register 00	TMR00	R/W	-	-	√	0000H
F0191H							
F0192H	Timer mode register 01	TMR01	R/W	-	-	√	0000H
F0193H							
F0194H	Timer mode register 02	TMR02	R/W	-	-	√	0000H
F0195H							
F0196H	Timer mode register 03	TMR03	R/W	-	-	√	0000H
F0197H							
F0198H	Timer mode register 04	TMR04	R/W	-	-	√	0000H
F0199H							
F019AH	Timer mode register 05	TMR05	R/W	-	-	√	0000H
F019BH							
F019CH	Timer mode register 06	TMR06	R/W	-	-	√	0000H
F019DH							
F019EH	Timer mode register 07	TMR07	R/W	-	-	√	0000H
F019FH							
F01A0H	Timer status register 00	TSR00L	TSR00	R	-	√	0000H
F01A1H		-			-		
F01A2H	Timer status register 01	TSR01L	TSR01	R	-	√	0000H
F01A3H		-			-		

Table 3-6. Extended SFR (2nd SFR) List (6/8)

Address	Special Function Register (SFR) Name	Symbol		R/W	Manipulable Bit Range			After Reset
					1-bit	8-bit	16-bit	
F01A4H	Timer status register 02	TSR02L	TSR02	R	–	√	√	0000H
F01A5H		–			–			
F01A6H	Timer status register 03	TSR03L	TSR03	R	–	√	√	0000H
F01A7H		–			–			
F01A8H	Timer status register 04	TSR04L	TSR04	R	–	√	√	0000H
F01A9H		–			–			
F01AAH	Timer status register 05	TSR05L	TSR05	R	–	√	√	0000H
F01ABH		–			–			
F01ACH	Timer status register 06	TSR06L	TSR06	R	–	√	√	0000H
F01ADH		–			–			
F01AEH	Timer status register 07	TSR07L	TSR07	R	–	√	√	0000H
F01AFH		–			–			
F01B0H	Timer channel enable status register 0	TE0L	TE0	R	√	√	√	0000H
F01B1H		–			–			
F01B2H	Timer channel start register 0	TS0L	TS0	R/W	√	√	√	0000H
F01B3H		–			–			
F01B4H	Timer channel stop register 0	TT0L	TT0	R/W	√	√	√	0000H
F01B5H		–			–			
F01B6H	Timer clock select register 0	TPS0		R/W	–	–	√	0000H
F01B7H								
F01B8H	Timer output register 0	TO0L	TO0	R/W	–	√	√	0000H
F01B9H		–			–			
F01BAH	Timer output enable register 0	TOE0L	TOE0	R/W	√	√	√	0000H
F01BBH		–			–			
F01BCH	Timer output level register 0	TOL0L	TOL0	R/W	–	√	√	0000H
F01BDH		–			–			
F01BEH	Timer output mode register 0	TOM0L	TOM0	R/W	–	√	√	0000H
F01BFH		–			–			
F01C0H	Timer counter register 10	TCR10		R	–	–	√	FFFFH
F01C1H								
F01C2H	Timer counter register 11	TCR11		R	–	–	√	FFFFH
F01C3H								
F01C4H	Timer counter register 12	TCR12		R	–	–	√	FFFFH
F01C5H								
F01C6H	Timer counter register 13	TCR13		R	–	–	√	FFFFH
F01C7H								

Table 3-6. Extended SFR (2nd SFR) List (7/8)

Address	Special Function Register (SFR) Name	Symbol		R/W	Manipulable Bit Range			After Reset
					1-bit	8-bit	16-bit	
F01C8H	Timer counter register 14	TCR14		R	-	-	√	FFFFH
F01C9H								
F01CAH	Timer counter register 15	TCR15		R	-	-	√	FFFFH
F01CBH								
F01CCH	Timer counter register 16	TCR16		R	-	-	√	FFFFH
F01CDH								
F01CEH	Timer counter register 17	TCR17		R	-	-	√	FFFFH
F01CFH								
<R> F01D0H	Timer mode register 10	TMR10		R/W	-	-	√	0000H
F01D1H								
<R> F01D2H	Timer mode register 11	TMR11		R/W	-	-	√	0000H
F01D3H								
<R> F01D4H	Timer mode register 12	TMR12		R/W	-	-	√	0000H
F01D5H								
<R> F01D6H	Timer mode register 13	TMR13		R/W	-	-	√	0000H
F01D7H								
<R> F01D8H	Timer mode register 14	TMR14		R/W	-	-	√	0000H
F01D9H								
<R> F01DAH	Timer mode register 15	TMR15		R/W	-	-	√	0000H
F01DBH								
<R> F01DCH	Timer mode register 16	TMR16		R/W	-	-	√	0000H
F01DDH								
<R> F01DEH	Timer mode register 17	TMR17		R/W	-	-	√	0000H
F01DFH								
F01E0H	Timer status register 10	TSR10L	TSR10	R	-	√	√	0000H
F01E1H		-						
F01E2H	Timer status register 11	TSR11L	TSR11	R	-	√	√	0000H
F01E3H		-						
F01E4H	Timer status register 12	TSR12L	TSR12	R	-	√	√	0000H
F01E5H		-						
F01E6H	Timer status register 13	TSR13L	TSR13	R	-	√	√	0000H
F01E7H		-						
F01E8H	Timer status register 14	TSR14L	TSR14	R	-	√	√	0000H
F01E9H		-						
F01EAH	Timer status register 15	TSR15L	TSR15	R	-	√	√	0000H
F01EBH		-						
F01ECH	Timer status register 16	TSR16L	TSR16	R	-	√	√	0000H
F01EDH		-						
F01EEH	Timer status register 17	TSR17L	TSR17	R	-	√	√	0000H
F01EFH		-						
F01F0H	Timer channel enable status register 1	TE1L	TE1	R	√	√	√	0000H
F01F1H		-						
F01F2H	Timer channel start register 1	TS1L	TS1	R/W	√	√	√	0000H
F01F3H		-						



Table 3-6. Extended SFR (2nd SFR) List (8/8)

Address	Special Function Register (SFR) Name	Symbol		R/W	Manipulable Bit Range			After Reset
					1-bit	8-bit	16-bit	
F01F4H	Timer channel stop register 1	TT1L	TT1	R/W	√	√	√	0000H
F01F5H		–			–			
F01F6H	Timer clock select register 1	TPS1		R/W	–	–	√	0000H
F01F7H								
F01F8H	Timer output register 1	TO1L	TO1	R/W	–	√	√	0000H
F01F9H		–			–			
F01FAH	Timer output enable register 1	TOE1L	TOE1	R/W	√	√	√	0000H
F01FBH		–			–			
F01FCH	Timer output level register 1	TOL1L	TOL1	R/W	–	√	√	0000H
F01FDH		–			–			
F01FEH	Timer output mode register 1	TOM1L	TOM1	R/W	–	√	√	0000H
F01FFH		–			–			
F0200H	DMA SFR address register 2	DSA2		R/W	–	√	–	00H
F0201H	DMA SFR address register 3	DSA3		R/W	–	√	–	00H
F0202H	DMA RAM address register 2L	DRA2L	DRA2	R/W	–	√	√	00H
F0203H	DMA RAM address register 2H	DRA2H		R/W	–	√		
F0204H	DMA RAM address register 3L	DRA3L	DRA3	R/W	–	√	√	00H
F0205H	DMA RAM address register 3H	DRA3H		R/W	–	√		
F0206H	DMA byte count register 2L	DBC2L	DBC2	R/W	–	√	√	00H
F0207H	DMA byte count register 2H	DBC2H		R/W	–	√		
F0208H	DMA byte count register 3L	DBC3L	DBC3	R/W	–	√	√	00H
F0209H	DMA byte count register 3H	DBC3H		R/W	–	√		
F020AH	DMA mode control register 2	DMC2		R/W	√	√	–	00H
F020BH	DMA mode control register 3	DMC3		R/W	√	√	–	00H
F020CH	DMA operation control register 2	DRC2		R/W	√	√	–	00H
F020DH	DMA operation control register 3	DRC3		R/W	√	√	–	00H
F0230H	IICA control register 00	IICCTL00		R/W	√	√	–	00H
F0231H	IICA control register 01	IICCTL01		R/W	√	√	–	00H
F0232H	IICA low-level width setting register 0	IICWL0		R/W	–	√	–	FFH
F0233H	IICA high-level width setting register 0	IICWH0		R/W	–	√	–	FFH
F0234H	Slave address register 0	SVA0		R/W	–	√	–	00H
F0238H	IICA control register 10	IICCTL10		R/W	√	√	–	00H
F0239H	IICA control register 11	IICCTL11		R/W	√	√	–	00H
F023AH	IICA low-level width setting register 1	IICWL1		R/W	–	√	–	FFH
F023BH	IICA high-level width setting register 1	IICWH1		R/W	–	√	–	FFH
F023CH	Slave address register 1	SVA1		R/W	–	√	–	00H
F02F0H	Flash memory CRC control register	CRC0CTL		R/W	√	√	–	00H
F02F2H	Flash memory CRC operation result register	PGCRCL		R/W	–	–	√	0000H
F02FAH	CRC data register	CRCD		R/W	–	–	√	0000H

**Remark** For SFRs in the SFR area, see **Table 3-5 SFR List**.

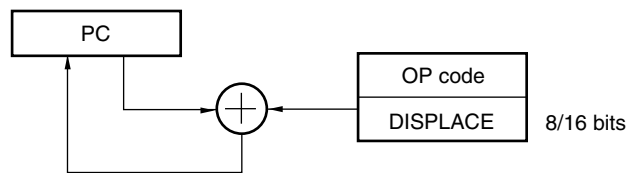
### 3.3 Instruction Address Addressing

#### 3.3.1 Relative addressing

**[Function]**

Relative addressing stores in the program counter (PC) the result of adding a displacement value included in the instruction word (signed complement data: -128 to +127 or -32768 to +32767) to the program counter (PC)'s value (the start address of the next instruction), and specifies the program address to be used as the branch destination. Relative addressing is applied only to branch instructions.

**Figure 3-28. Outline of Relative Addressing**



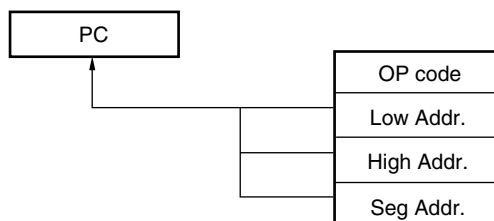
#### 3.3.2 Immediate addressing

**[Function]**

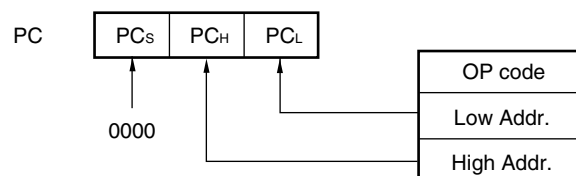
Immediate addressing stores immediate data of the instruction word in the program counter, and specifies the program address to be used as the branch destination.

For immediate addressing, CALL !!addr20 or BR !!addr20 is used to specify 20-bit addresses and CALL !addr16 or BR !addr16 is used to specify 16-bit addresses. 0000 is set to the higher 4 bits when specifying 16-bit addresses.

**Figure 3-29. Example of CALL !!addr20/BR !!addr20**



**Figure 3-30. Example of CALL !addr16/BR !addr16**



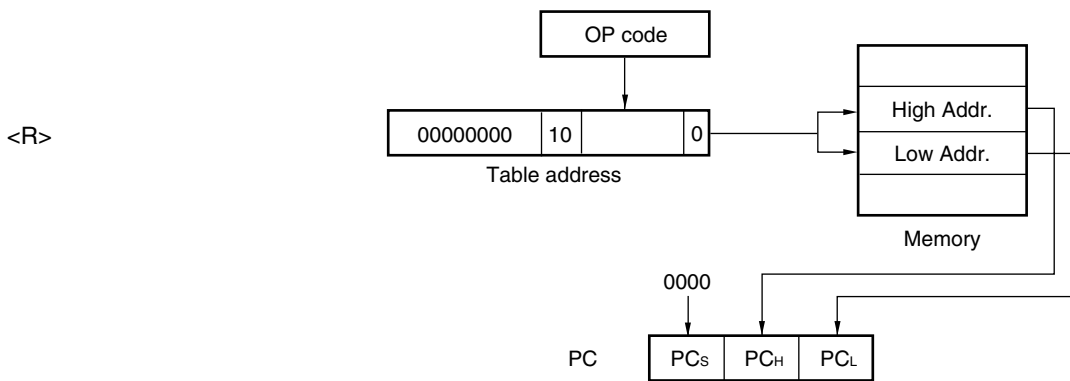
3.3.3 Table indirect addressing

[Function]

Table indirect addressing specifies a table address in the CALLT table area (0080H to 00BFH) with the 5-bit immediate data in the instruction word, stores the contents at that table address and the next address in the program counter (PC) as 16-bit data, and specifies the program address. Table indirect addressing is applied only for CALLT instructions.

In the RL78 microcontrollers, branching is enabled only to the 64 KB space from 00000H to 0FFFFH.

Figure 3-31. Outline of Table Indirect Addressing

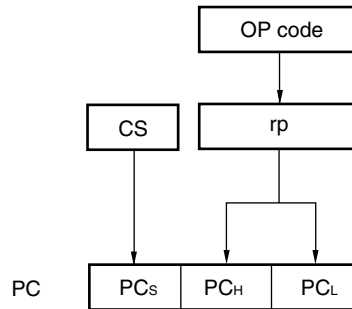


### 3.3.4 Register direct addressing

**[Function]**

Register direct addressing stores in the program counter (PC) the contents of a general-purpose register pair (AX/BC/DE/HL) and CS register of the current register bank specified with the instruction word as 20-bit data, and specifies the program address. Register direct addressing can be applied only to the CALL AX, BC, DE, HL, and BR AX instructions.

**Figure 3-32. Outline of Register Direct Addressing**



### 3.4 Addressing for Processing Data Addresses

#### 3.4.1 Implied addressing

**[Function]**

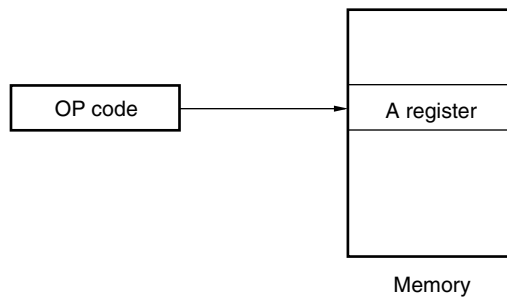
Instructions for accessing registers (such as accumulators) that have special functions are directly specified with the instruction word, without using any register specification field in the instruction word.

**[Operand format]**

Because implied addressing can be automatically employed with an instruction, no particular operand format is necessary.

Implied addressing can be applied only to MULU X.

**Figure 3-33. Outline of Implied Addressing**



#### 3.4.2 Register addressing

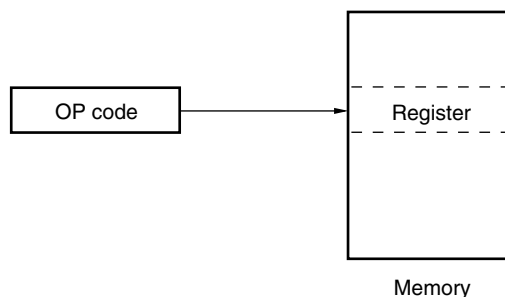
**[Function]**

Register addressing accesses a general-purpose register as an operand. The instruction word of 3-bit long is used to select an 8-bit register and the instruction word of 2-bit long is used to select a 16-bit register.

**[Operand format]**

Identifier	Description
r	X, A, C, B, E, D, L, H
rp	AX, BC, DE, HL

**Figure 3-34. Outline of Register Addressing**



3.4.3 Direct addressing

[Function]

Direct addressing uses immediate data in the instruction word as an operand address to directly specify the target address.

[Operand format]

Identifier	Description
ADDR16	Label or 16-bit immediate data (only the space from F0000H to FFFFFH is specifiable)
ES: ADDR16	Label or 16-bit immediate data (higher 4-bit addresses are specified by the ES register)

Figure 3-35. Example of ADDR16

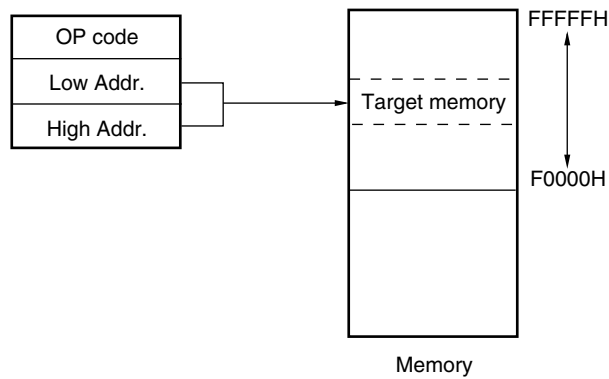
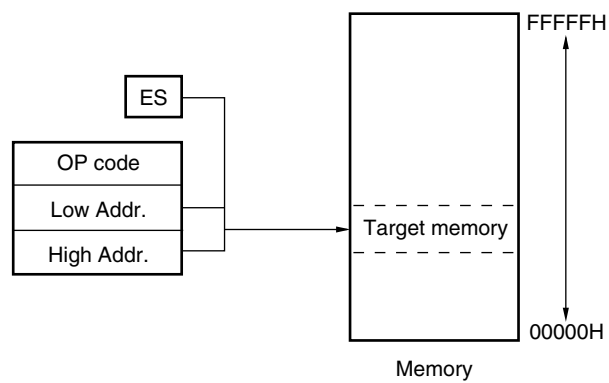


Figure 3-36. Example of ES:ADDR16



3.4.4 Short direct addressing

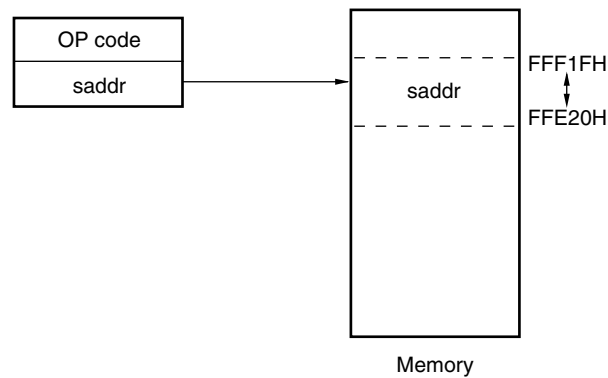
[Function]

Short direct addressing directly specifies the target addresses using 8-bit data in the instruction word. This type of addressing is applied only to the space from FFE20H to FFF1FH.

[Operand format]

Identifier	Description
SADDR	Label, FFE20H to FFF1FH immediate data, or 0FE20H to 0FF1FH immediate data (only the space from FFE20H to FFF1FH is specifiable)
SADDRP	Label, FFE20H to FFF1FH immediate data, or 0FE20H to 0FF1FH immediate data (even address only) (only the space from FFE20H to FFF1FH is specifiable)

Figure 3-37. Outline of Short Direct Addressing



**Remark** SADDR and SADDRP are used to describe the values of addresses FE20H to FF1FH with 16-bit immediate data (higher 4 bits of actual address are omitted), and the values of addresses FFE20H to FFF1FH with 20-bit immediate data.

Regardless of whether SADDR or SADDRP is used, addresses within the space from FFE20H to FFF1FH are specified for the memory.

### 3.4.5 SFR addressing

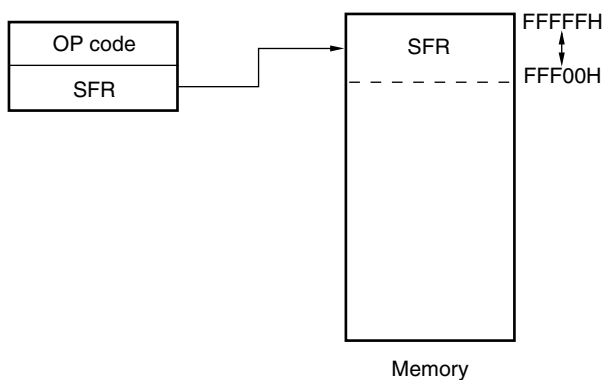
#### [Function]

SFR addressing directly specifies the target SFR addresses using 8-bit data in the instruction word. This type of addressing is applied only to the space from FFF00H to FFFFFH.

#### [Operand format]

Identifier	Description
SFR	SFR name
SFRP	16-bit-manipulatable SFR name (even address only)

**Figure 3-38. Outline of SFR Addressing**





3.4.6 Register indirect addressing

[Function]

Register indirect addressing directly specifies the target addresses using the contents of the register pair specified with the instruction word as an operand address.

[Operand format]

Identifier	Description
-	[DE], [HL] (only the space from F0000H to FFFFFH is specifiable)
-	ES:[DE], ES:[HL] (higher 4-bit addresses are specified by the ES register)

Figure 3-39. Example of [DE], [HL]

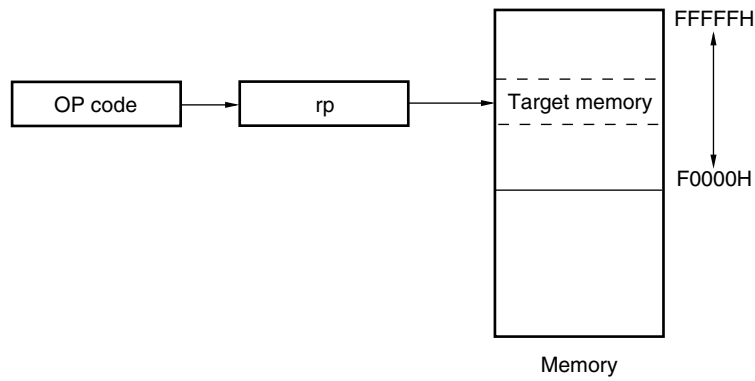
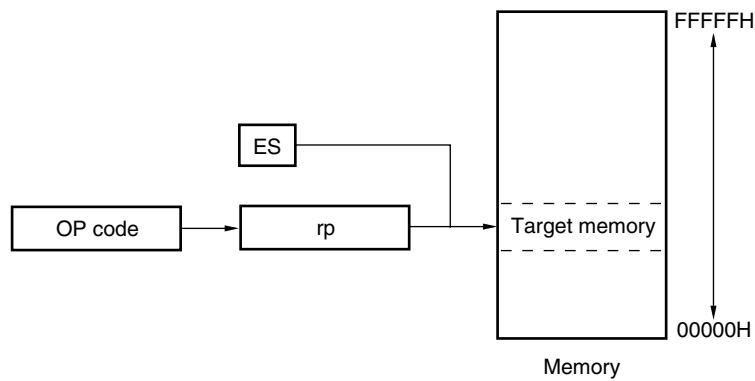


Figure 3-40. Example of ES:[DE], ES:[HL]



3.4.7 Based addressing

[Function]

Based addressing uses the contents of a register pair specified with the instruction word as a base address, and 8-bit immediate data or 16-bit immediate data as offset data. The sum of these values is used to specify the target address.

[Operand format]

Identifier	Description
-	[HL + byte], [DE + byte], [SP + byte] (only the space from F0000H to FFFFFH is specifiable)
-	word[B], word[C] (only the space from F0000H to FFFFFH is specifiable)
-	word[BC] (only the space from F0000H to FFFFFH is specifiable)
-	ES:[HL + byte], ES:[DE + byte] (higher 4-bit addresses are specified by the ES register)
-	ES:word[B], ES:word[C] (higher 4-bit addresses are specified by the ES register)
-	ES:word[BC] (higher 4-bit addresses are specified by the ES register)

Figure 3-41. Example of [SP+byte]

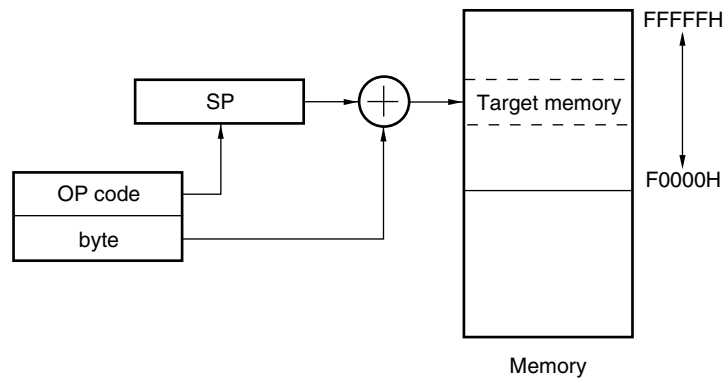


Figure 3-42. Example of [HL + byte], [DE + byte]

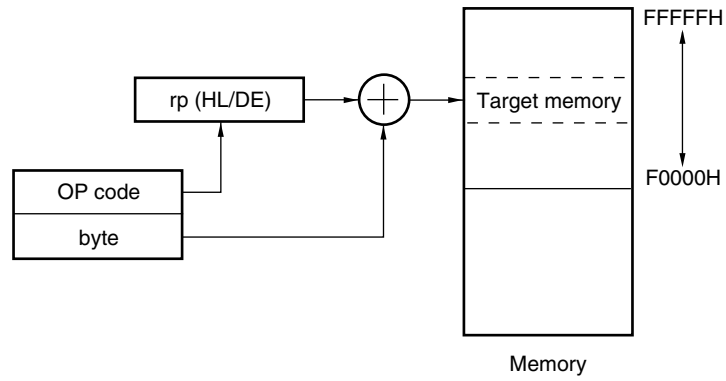


Figure 3-43. Example of word[B], word[C]

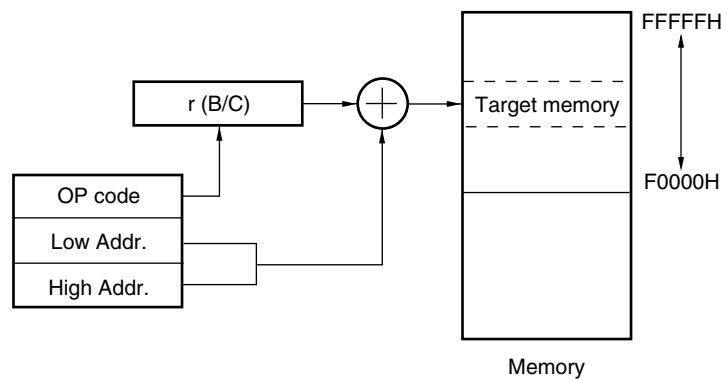


Figure 3-44. Example of word[BC]

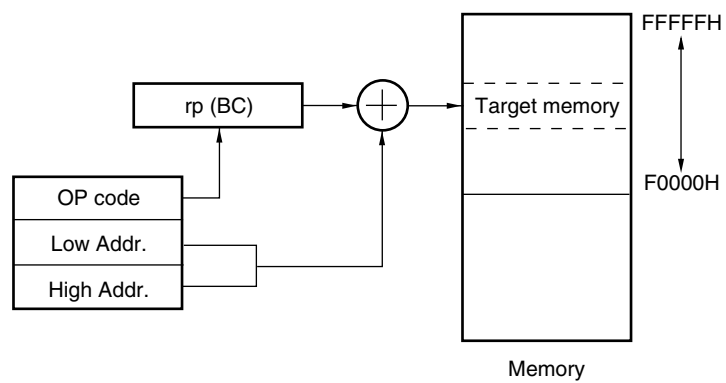


Figure 3-45. Example of ES:[HL + byte], ES:[DE + byte]

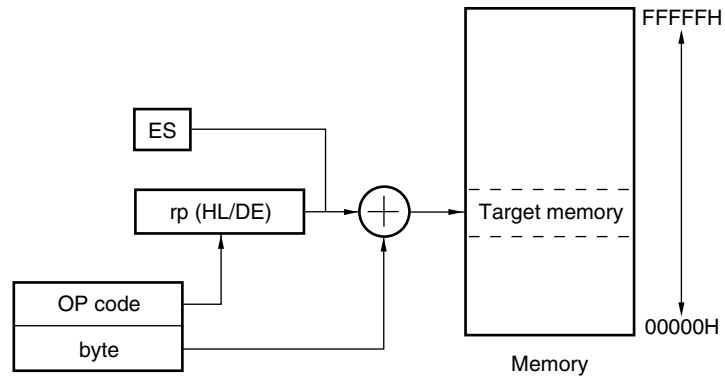


Figure 3-46. Example of ES:word[B], ES:word[C]

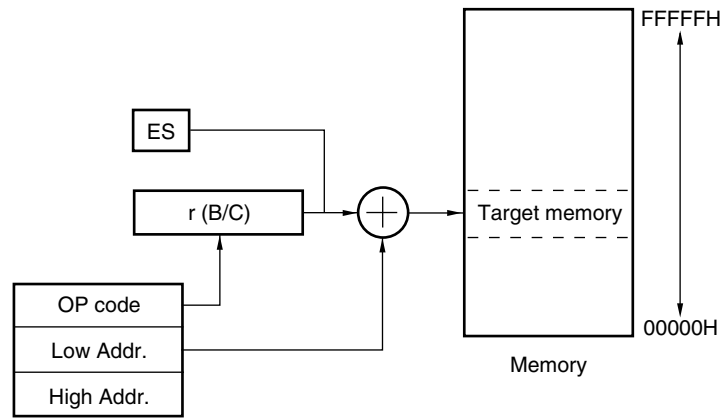
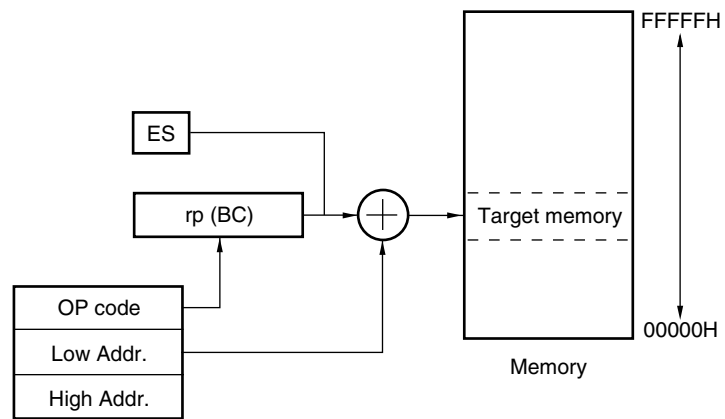


Figure 3-47. Example of ES:word[BC]



3.4.8 Based indexed addressing

[Function]

Based indexed addressing uses the contents of a register pair specified with the instruction word as the base address, and the content of the B register or C register similarly specified with the instruction word as offset address. The sum of these values is used to specify the target address.

[Operand format]

Identifier	Description
-	[HL+B], [HL+C] (only the space from F0000H to FFFFFH is specifiable)
-	ES:[HL+B], ES:[HL+C] (higher 4-bit addresses are specified by the ES register)

Figure 3-48. Example of [HL+B], [HL+C]

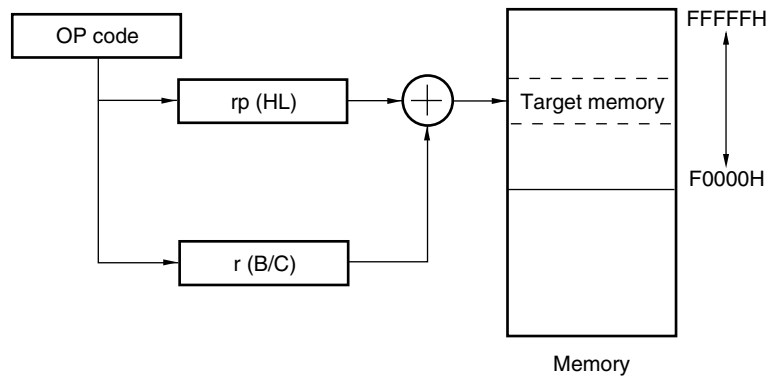
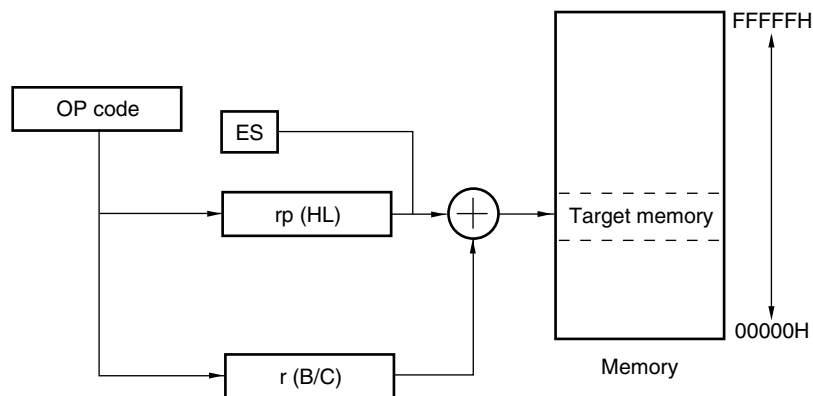


Figure 3-49. Example of ES:[HL+B], ES:[HL+C]



### 3.4.9 Stack addressing

**[Function]**

The stack area is indirectly addressed with the stack pointer (SP) contents. This addressing is automatically employed when the PUSH, POP, subroutine call, and return instructions are executed or the register is saved/restored upon generation of an interrupt request.

Stack addressing is applied only to the internal RAM area.

**[Operand format]**

Identifier	Description
–	PUSH AX/BC/DE/HL POP AX/BC/DE/HL CALL/CALLT RET BRK RETB (Interrupt request generated) RETI

## CHAPTER 4 PORT FUNCTIONS

## 4.1 Port Functions

Pin I/O buffer power supplies depend on the product. The relationship between these power supplies and the pins is shown below.

Table 4-1. Pin I/O Buffer Power Supplies

## (1) 20-pin, 24-pin, 25-pin, 30-pin, 32-pin, 36-pin, 40-pin, 44-pin, 48-pin, 52-pin products

Power Supply	Corresponding Pins
V <sub>DD</sub>	All pins

## (2) 64-pin products

Power Supply	Corresponding Pins
EV <sub>DD0</sub>	Port pins other than P20 to P27, P121 to P124, and P137
V <sub>DD</sub>	<ul style="list-style-type: none"> <li>• P20 to P27, P121 to P124, and P137</li> <li>• Pins other than port pins</li> </ul>

## (3) 80-pin products

Power Supply	Corresponding Pins
EV <sub>DD0</sub>	Port pins other than P20 to P27, P121 to P124, P137, and P150 to P153
V <sub>DD</sub>	<ul style="list-style-type: none"> <li>• P20 to P27, P121 to P124, P137, and P150 to P153</li> <li>• Pins other than port pins</li> </ul>

## (4) 100-pin products

Power Supply	Corresponding Pins
EV <sub>DD0</sub> , EV <sub>DD1</sub>	Port pins other than P20 to P27, P121 to P124, P137, and P150 to P156
V <sub>DD</sub>	<ul style="list-style-type: none"> <li>• P20 to P27, P121 to P124, P137, and P150 to P156</li> <li>• Pins other than port pins</li> </ul>

## (5) 128-pin products

Power Supply	Corresponding Pins
EV <sub>DD0</sub> , EV <sub>DD1</sub>	Port pins other than P20 to P27, P121 to P124, P137, and P150 to P156
V <sub>DD</sub>	<ul style="list-style-type: none"> <li>• P20 to P27, P121 to P124, P137, and P150 to P156</li> <li>• Pins other than port pins</li> </ul>

The RL78/G13 microcontrollers are provided with digital I/O ports, which enable variety of control operations.

In addition to the function as digital I/O ports, these ports have several alternate functions. For details of the alternate functions, see **CHAPTER 2 PIN FUNCTIONS**.

## 4.2 Port Configuration

Ports include the following hardware.

**Table 4-2. Port Configuration (1/2)**

Item	Configuration
Control registers	Port mode registers (PM0 to PM12, PM14, PM15) Port registers (P0 to P15) Pull-up resistor option registers (PU0, PU1, PU3 to PU12, PU14) Port input mode registers (PIM0, PIM1, PIM4, PIM5, PIM8, PIM14) Port output mode registers (POM0, POM1, POM4, POM5, POM7 to POM9, POM14) Port mode control registers (PMC0, PMC3, PMC10 to PMC12, PMC14) A/D port configuration register (ADPC) Peripheral I/O redirection register (PIOR) Global digital input disable register (GDIDIS)
Port	<ul style="list-style-type: none"> <li>• 20-pin products Total: 16 (CMOS I/O: 13, CMOS input: 3)</li> <li>• 24-pin products Total: 20 (CMOS I/O: 15, CMOS input: 3, N-ch open drain I/O: 2)</li> <li>• 25-pin products Total: 21 (CMOS I/O: 15, CMOS input: 3, CMOS output: 1, N-ch open drain I/O: 2)</li> <li>• 30-pin products Total: 26 (CMOS I/O: 21, CMOS input: 3, N-ch open drain I/O: 2)</li> <li>• 32-pin products Total: 28 (CMOS I/O: 22, CMOS input: 3, N-ch open drain I/O: 3)</li> <li>• 36-pin products Total: 32 (CMOS I/O: 26, CMOS input: 3, N-ch open drain I/O: 3)</li> <li>• 40-pin products Total: 36 (CMOS I/O: 28, CMOS input: 5, N-ch open drain I/O: 3)</li> <li>• 44-pin products Total: 40 (CMOS I/O: 31, CMOS input: 5, N-ch open drain I/O: 4)</li> <li>• 48-pin products Total: 44 (CMOS I/O: 34, CMOS input: 5, CMOS output: 1, N-ch open drain I/O: 4)</li> <li>• 52-pin products Total: 48 (CMOS I/O: 38, CMOS input: 5, CMOS output: 1, N-ch open drain I/O: 4)</li> <li>• 64-pin products Total: 58 (CMOS I/O: 48, CMOS input: 5, CMOS output: 1, N-ch open drain I/O: 4)</li> </ul>



**Table 4-2. Port Configuration (2/2)**

Item	Configuration																												
Port	<ul style="list-style-type: none"> <li>• 80-pin products Total: 74 (CMOS I/O: 64, CMOS input: 5, CMOS output: 1, N-ch open drain I/O: 4)</li> <li>• 100-pin products Total: 92 (CMOS I/O: 82, CMOS input: 5, CMOS output: 1, N-ch open drain I/O: 4)</li> <li>• 128-pin products Total: 120 (CMOS I/O: 110, CMOS input: 5, CMOS output: 1, N-ch open drain I/O: 4)</li> </ul>																												
Pull-up resistor	<table border="0"> <tbody> <tr><td>• 20-pin products</td><td>Total: 10</td></tr> <tr><td>• 24-pin products</td><td>Total: 12</td></tr> <tr><td>• 25-pin products</td><td>Total: 12</td></tr> <tr><td>• 30-pin products</td><td>Total: 17</td></tr> <tr><td>• 32-pin products</td><td>Total: 18</td></tr> <tr><td>• 36-pin products</td><td>Total: 20</td></tr> <tr><td>• 40-pin products</td><td>Total: 21</td></tr> <tr><td>• 44-pin products</td><td>Total: 23</td></tr> <tr><td>• 48-pin products</td><td>Total: 26</td></tr> <tr><td>• 52-pin products</td><td>Total: 30</td></tr> <tr><td>• 64-pin products</td><td>Total: 40</td></tr> <tr><td>• 80-pin products</td><td>Total: 52</td></tr> <tr><td>• 100-pin products</td><td>Total: 67</td></tr> <tr><td>• 128-pin products</td><td>Total: 95</td></tr> </tbody> </table>	• 20-pin products	Total: 10	• 24-pin products	Total: 12	• 25-pin products	Total: 12	• 30-pin products	Total: 17	• 32-pin products	Total: 18	• 36-pin products	Total: 20	• 40-pin products	Total: 21	• 44-pin products	Total: 23	• 48-pin products	Total: 26	• 52-pin products	Total: 30	• 64-pin products	Total: 40	• 80-pin products	Total: 52	• 100-pin products	Total: 67	• 128-pin products	Total: 95
• 20-pin products	Total: 10																												
• 24-pin products	Total: 12																												
• 25-pin products	Total: 12																												
• 30-pin products	Total: 17																												
• 32-pin products	Total: 18																												
• 36-pin products	Total: 20																												
• 40-pin products	Total: 21																												
• 44-pin products	Total: 23																												
• 48-pin products	Total: 26																												
• 52-pin products	Total: 30																												
• 64-pin products	Total: 40																												
• 80-pin products	Total: 52																												
• 100-pin products	Total: 67																												
• 128-pin products	Total: 95																												

**Caution** Most of the following descriptions in this chapter use the 128-pin products with the 00H setting in peripheral I/O redirection register (PIOR) as an example.

#### 4.2.1 Port 0

Port 0 is an I/O port with an output latch. Port 0 can be set to the input mode or output mode in 1-bit units using port mode register 0 (PM0). When the P00 to P07 pins are used as an input port, use of an on-chip pull-up resistor can be specified in 1-bit units by pull-up resistor option register 0 (PU0).

Input to the P01, P03 and P04 pins can be specified through a normal input buffer or a TTL input buffer in 1-bit units using port input mode register 0 (PIM0).

Output from the P00 and P02 to P04 pins can be specified as N-ch open-drain output ( $V_{DD}$  tolerance) in 1-bit units using port output mode register 0 (POM0).

<R> Input to the P00 to P03 pins can be specified as analog input or digital input in 1-bit units, using port mode control register 0 (PMC0).

This port can also be used for timer I/O, A/D converter analog input, serial interface data I/O, and clock I/O.

<R> When reset signal is generated, the following configuration will be set.

- P00 and P01 pins of the 20, 24, 25, 30, and 32-pin products ... Analog input
- P00, P01 and P04 to P07 pins of the other products ... Input mode
- P02 and P03 pins of the other products ... Analog input

&lt;R&gt;

Table 4-3. Settings of Registers When Using Port 0

Pin Name		PM0×	PIM0×	POM0×	PMC0×	Alternate Function Setting	Remark
Name	I/O						
P00	Input	1	–	×	0 <sup>Note 1</sup>	×	
	Output	0		0	0 <sup>Note 1</sup>	TxD1 output = 1 <sup>Note 3</sup>	CMOS output
		0		1	0 <sup>Note 1</sup>		N-ch O.D. output
P01	Input	1	0	–	0 <sup>Note 1</sup>	×	CMOS input
		1	1		0 <sup>Note 1</sup>	×	TTL input
	Output	0	×		0 <sup>Note 1</sup>	TO00 output = 0 <sup>Note 4</sup>	
P02	Input	1	–	×	0 <sup>Note 2</sup>	×	
		0		0	0 <sup>Note 2</sup>	SO10/TxD1 output = 1 <sup>Note 5</sup>	CMOS output
	0	1		0 <sup>Note 2</sup>	N-ch O.D. output		
P03	Input	1	0	×	0 <sup>Note 2</sup>	×	CMOS input
		1	1	×	0 <sup>Note 2</sup>	×	TTL input
	Output	0	×	0	0 <sup>Note 2</sup>	SDA10 output = 1 <sup>Note 5</sup>	CMOS output
		0	×	1	0 <sup>Note 2</sup>		N-ch O.D. output
P04	Input	1	0	×	–	×	CMOS input
		1	1	×		×	TTL input
	Output	0	×	0		SCK10/SCL10 output = 1 <sup>Note 5</sup>	CMOS output
		0	×	1			N-ch O.D. output
P05, P06	Input	1	–	–	–	TO05 output, TO06 output = 0 <sup>Note 6</sup>	
	Output	0					
P07	Input	1	–	–	–	–	
	Output	0					

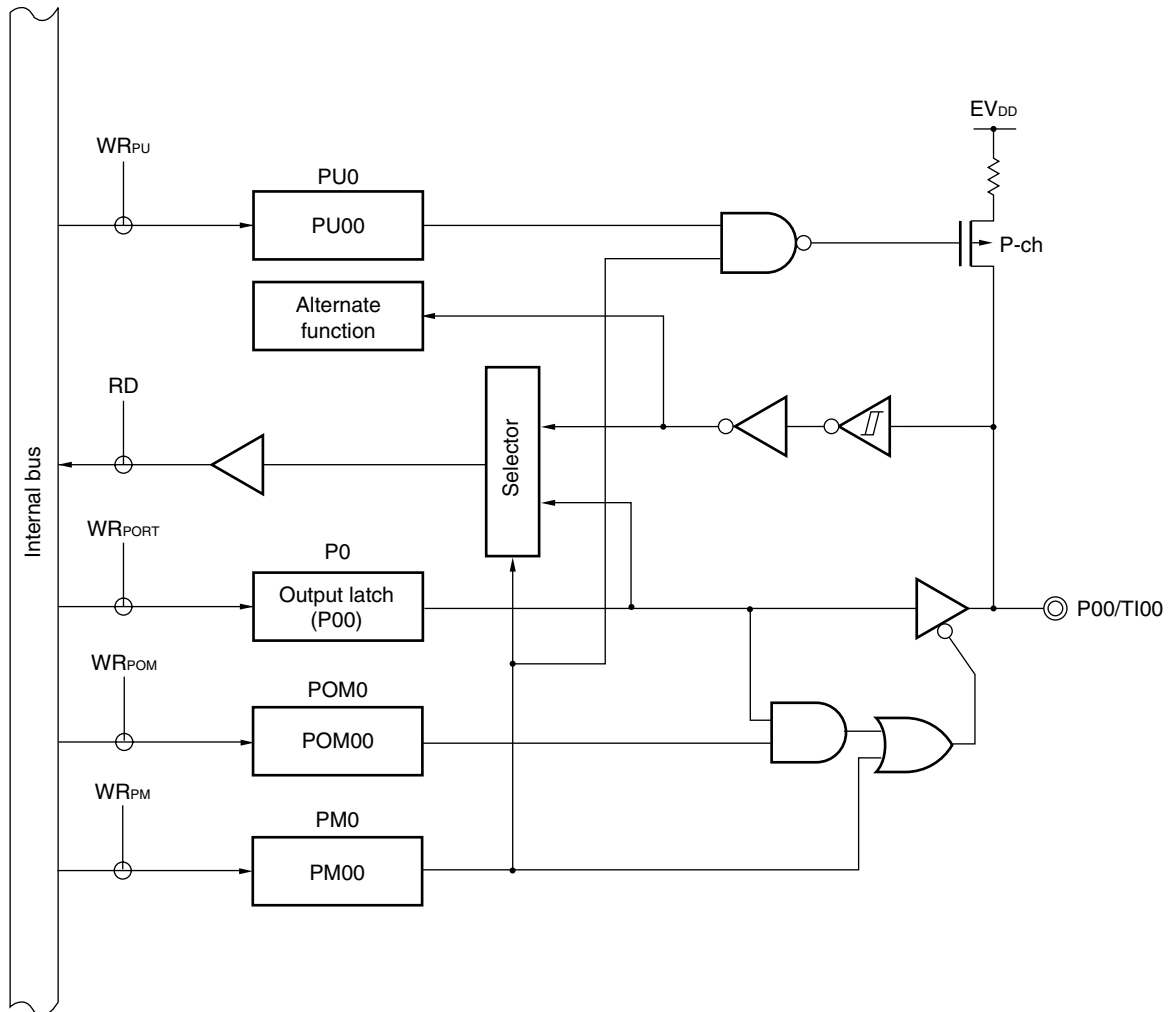
- Notes**
- 20-, 24-, 25-, 30-, 32-pin products only
  - 52-, 64-, 80-, 100-, 128-pin products only
  - To use P00/TxD1 as a general-purpose port in 20- to 48-pin products, set serial channel enable status register 0 (SE0), serial output register 0 (SO0) and serial output enable register 0 (SOE0) to the default status.
  - To use P01/TO00 as a general-purpose port, set bit 0 (TO00) of timer output register 0 (TO0) and bit 0 (TOE00) of timer output enable register 0 (TOE0) to "0", which is the same as their default status setting.
  - To use P02/SO10/TxD1/ANI17, P03/SI10/RxD1/SDA10/ANI16, or P04/SCK10/SCL10 as a general-purpose port, set serial channel enable status register 0 (SE0), serial output register 0 (SO0) and serial output enable register 0 (SOE0) to the default status.
  - 64-, 80-pin products only

**Remark**

- ×: don't care
- PM0×: Port mode register 0
- PIM0×: Port input mode register 0
- POM0×: Port output mode register 0
- PMC0×: Port mode control register 0

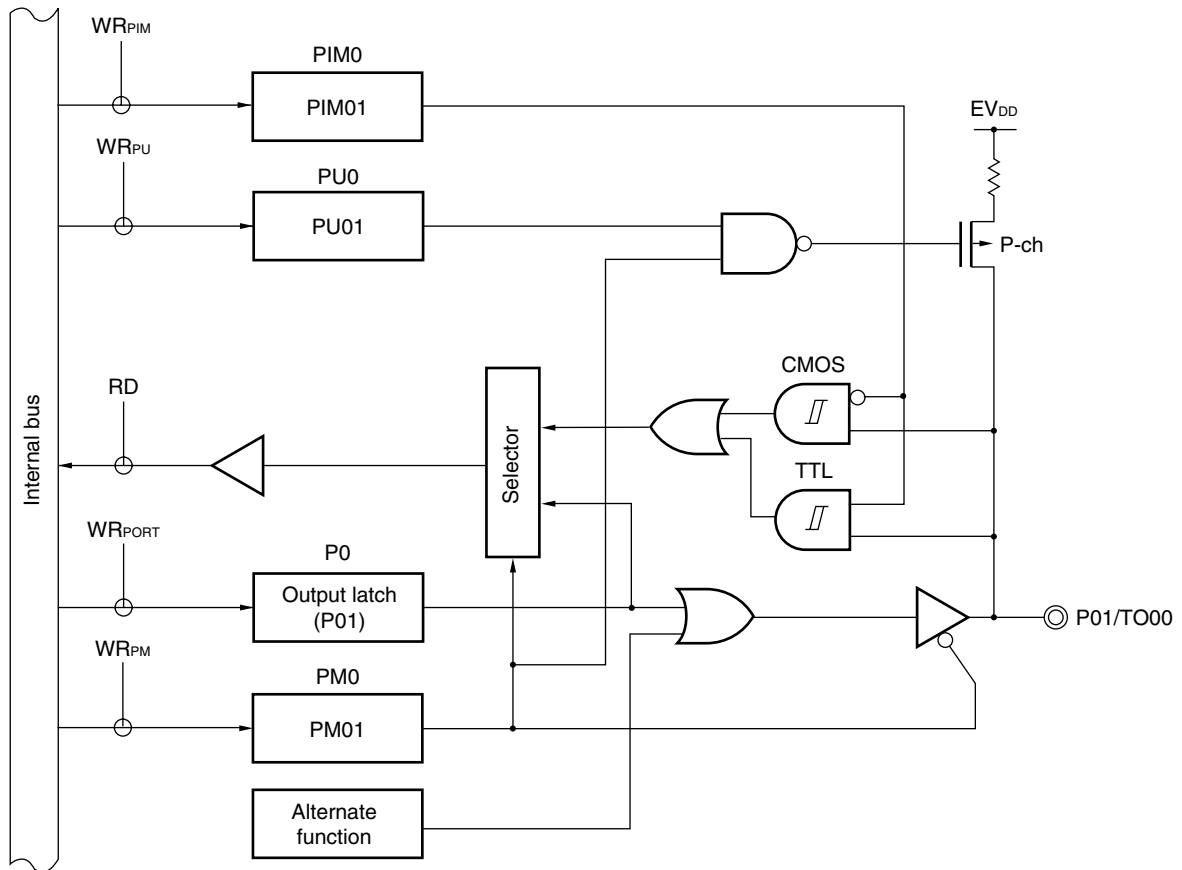
<R> For example, figures 4-1 to 4-6 show block diagrams of port 0 for 128-pin products when PIOR = 00H.

Figure 4-1. Block Diagram of P00



- P0: Port register 0
- PU0: Pull-up resistor option register 0
- PM0: Port mode register 0
- POM0: Port output mode register 0
- RD: Read signal
- WR<sub>xx</sub>: Write signal

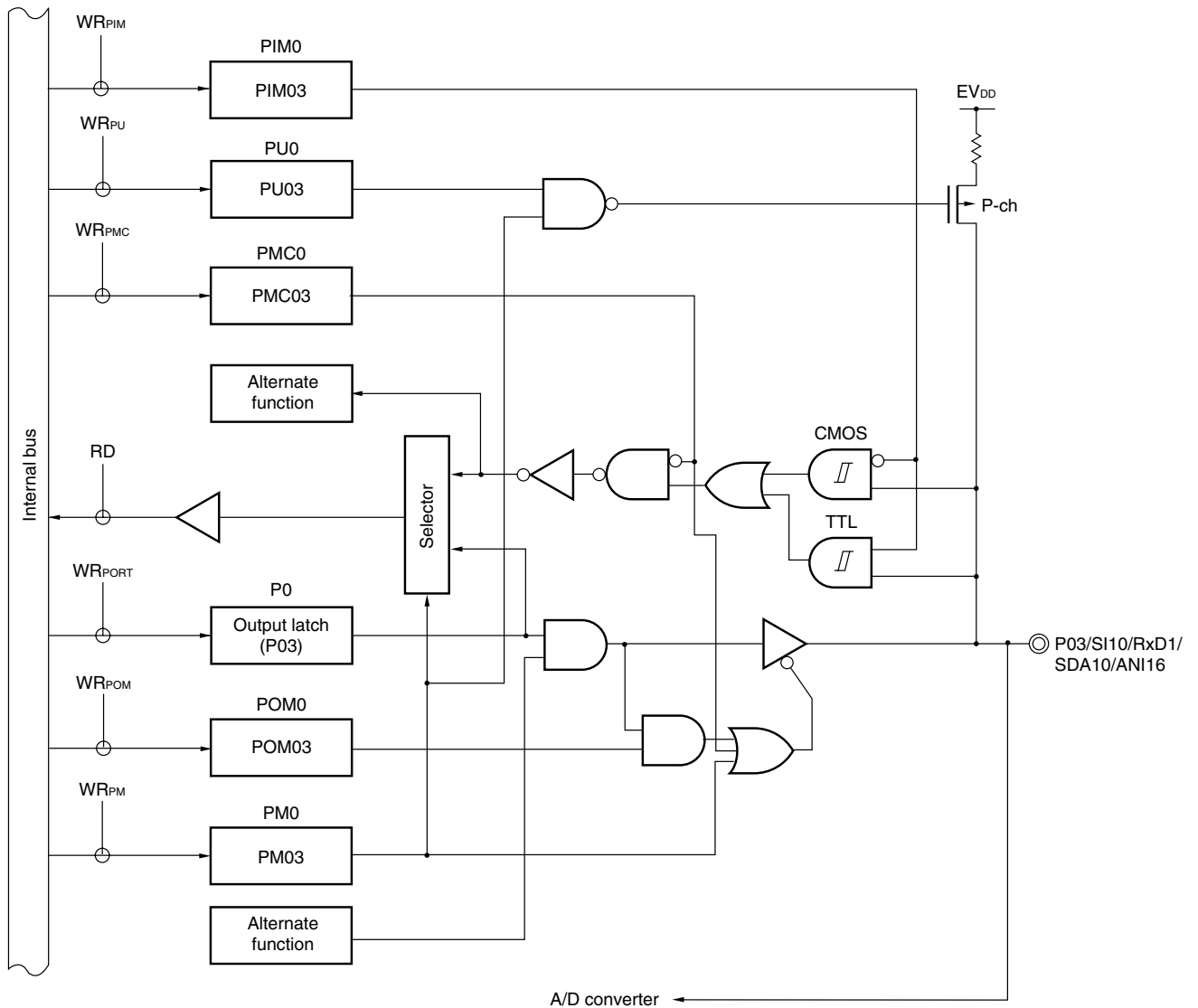
Figure 4-2. Block Diagram of P01



- P0: Port register 0
- PU0: Pull-up resistor option register 0
- PM0: Port mode register 0
- PIM0: Port input mode register 0
- RD: Read signal
- WR<sub>xx</sub>: Write signal

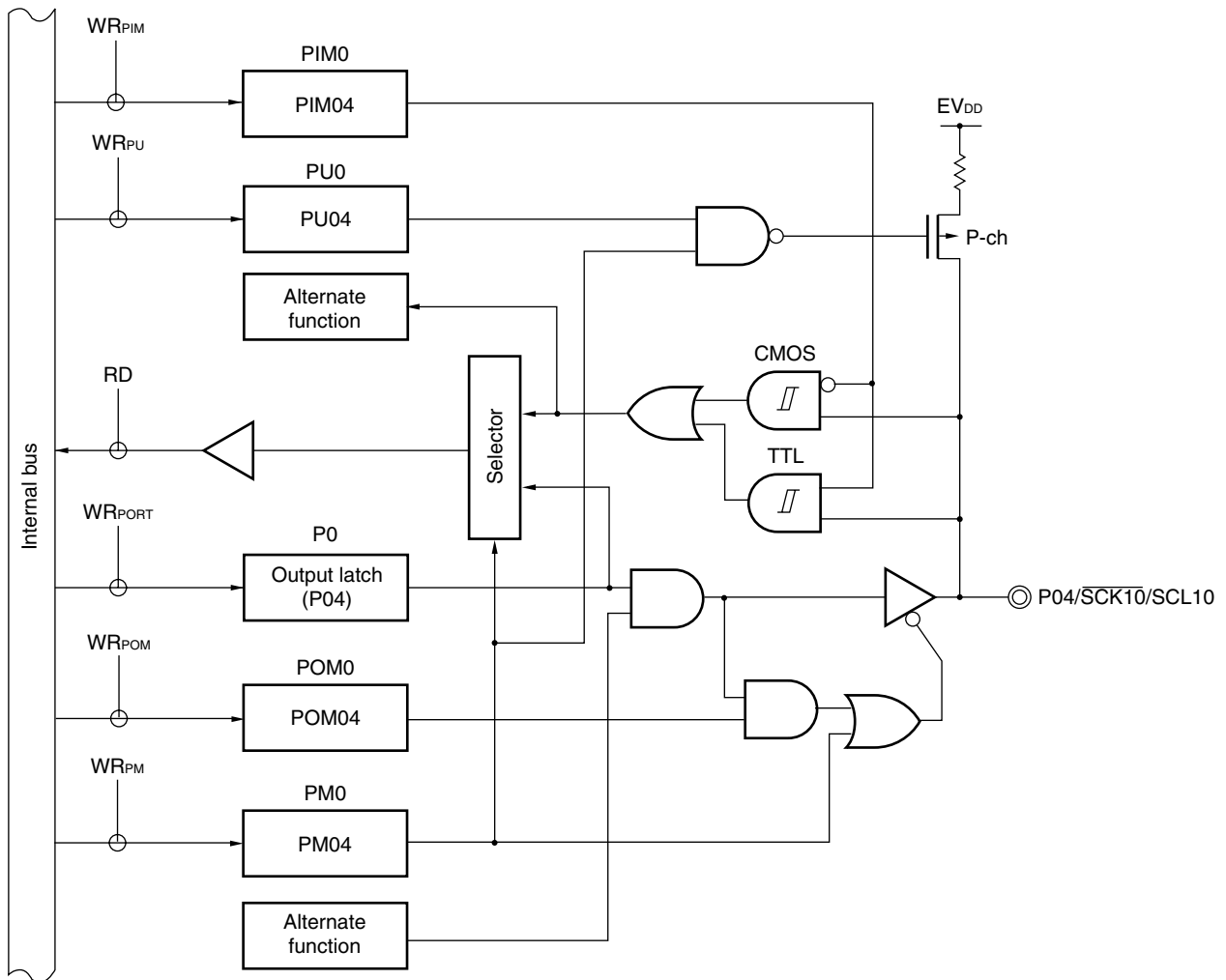


Figure 4-4. Block Diagram of P03



- P0: Port register 0
- PU0: Pull-up resistor option register 0
- PM0: Port mode register 0
- PIM0: Port input mode register 0
- POM0: Port output mode register 0
- PMC0: Port mode control register 0
- RD: Read signal
- WR<sub>xx</sub>: Write signal

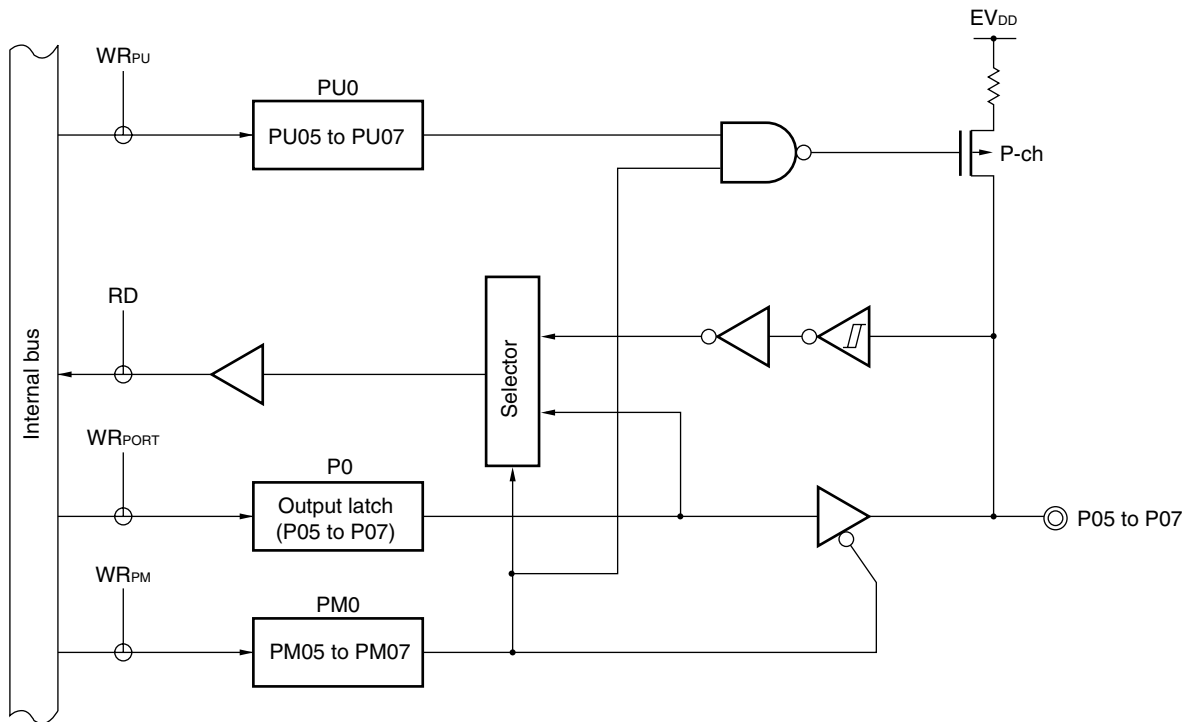
Figure 4-5. Block Diagram of P04



- P0: Port register 0
- PU0: Pull-up resistor option register 0
- PM0: Port mode register 0
- PIM0: Port input mode register 0
- POM0: Port output mode register 0
- RD: Read signal
- WR<sub>xx</sub>: Write signal



Figure 4-6. Block Diagram of P05 and P07



- P0: Port register 0
- PU0: Pull-up resistor option register 0
- PM0: Port mode register 0
- RD: Read signal
- $WR_{xx}$ : Write signal

### 4.2.2 Port 1

Port 1 is an I/O port with an output latch. Port 1 can be set to the input mode or output mode in 1-bit units using port mode register 1 (PM1). When the P10 to P17 pins are used as an input port, use of an on-chip pull-up resistor can be specified in 1-bit units by pull-up resistor option register 1 (PU1).

Input to the P10, P11, and P13 to P17 pins can be specified through a normal input buffer or a TTL input buffer in 1-bit units using port input mode register 1 (PIM1).

Output from the P10 to P15 and P17 pins can be specified as N-ch open-drain output ( $V_{DD}$  tolerance) in 1-bit units using port output mode register 1 (POM1).

This port can also be used for serial interface data I/O, clock I/O, programming UART I/O, timer I/O, and external interrupt request input.

Reset signal generation sets port 1 to input mode.

<R>

**Table 4-4. Settings of Registers When Using Port 1 (1/2)**

Pin Name		PM1 $\times$	PIM1 $\times$	POM1 $\times$	PMC $\times\times$	Alternate Function Setting <sup>Note 10</sup>	Remark
Name	I/O						
P10	Input	1	0 <sup>Note 1</sup>	$\times$	-	$\times$	CMOS input
		1	1 <sup>Note 1</sup>	$\times$		$\times$	TTL input
	Output	0	$\times$	0 <sup>Note 1</sup>		SCK00/SCL00 output = 1 <sup>Note 2</sup> (TO07 output = 0 <sup>Note 7</sup> )	CMOS output
		0	$\times$	1 <sup>Note 1</sup>			N-ch O.D. output
P11	Input	1	0 <sup>Note 1</sup>	$\times$	-	$\times$	CMOS input
		1	1 <sup>Note 1</sup>	$\times$		$\times$	TTL input
	Output	0	$\times$	0 <sup>Note 1</sup>		SDA00 output = 1 <sup>Note 2</sup> (TO06 output = 0 <sup>Note 7</sup> )	CMOS output
		0	$\times$	1 <sup>Note 1</sup>			N-ch O.D. output
P12	Input	1	-	$\times$	-	$\times$	CMOS input
	Output	0	-	0		SO00/TxD1 output = 1 <sup>Note 2</sup> (TO05 output = 0 <sup>Note 7</sup> )	CMOS output
		0	-	1			N-ch O.D. output
P13	Input	1	0	$\times$	-	$\times$	CMOS input
		1	1	$\times$		$\times$	TTL input
	Output	0	$\times$	0		TxD2/SO20 output = 1 <sup>Note 2</sup> (TO04 output = 0 <sup>Note 7</sup> , SDAA0 output = 0 <sup>Note 8</sup> )	CMOS output
		0	$\times$	1			N-ch O.D. output
P14	Input	1	0	$\times$	-	$\times$	CMOS input
		1	1	$\times$		$\times$	TTL input
	Output	0	$\times$	0		SDA20 output = 1 <sup>Note 2</sup> (TO03 output = 0 <sup>Note 7</sup> , SCLA0 output = 0 <sup>Note 8</sup> )	CMOS output
		0	$\times$	1			N-ch O.D. output
P15	Input	1	0	$\times$	-	$\times$	CMOS input
		1	1	$\times$		$\times$	TTL input
	Output	0	$\times$	0		SCK20/SCL20 output = 1 <sup>Note 2</sup> PCLBUZ1 output = 0 <sup>Note 7</sup> (TO02 output = 0 <sup>Note 8</sup> )	CMOS output
		0	$\times$	1			N-ch O.D. output

(Notes and Remark are listed on the next page.)

&lt;R&gt;

Table 4-4. Settings of Registers When Using Port 1 (2/2)

Pin Name		PM1 <sub>x</sub>	PIM1 <sub>x</sub>	POM1 <sub>x</sub>	PMC <sub>x</sub> <sub>x</sub>	Alternate Function Setting <sup>Note 10</sup>	Remark
Name	I/O						
P16	Input	1	0	×	-	×	CMOS input
		1	1	×		×	TTL input
	Output	0	×	0		TO01 output = 0 <sup>Note 4</sup> SO11 output = 1 <sup>Note 5</sup>	CMOS output
P17	Input	1	0	×	-	×	CMOS input
		1	1	×		×	TTL input
	Output	0	×	0		TO02 output = 0 <sup>Note 4</sup> SDA11 output = 0 <sup>Note 5</sup> SO11 output = 0 <sup>Note 6</sup> (SO00/TxD0 output = 1 <sup>Note 9</sup> )	CMOS output
		0	×	1			N-ch O.D. output

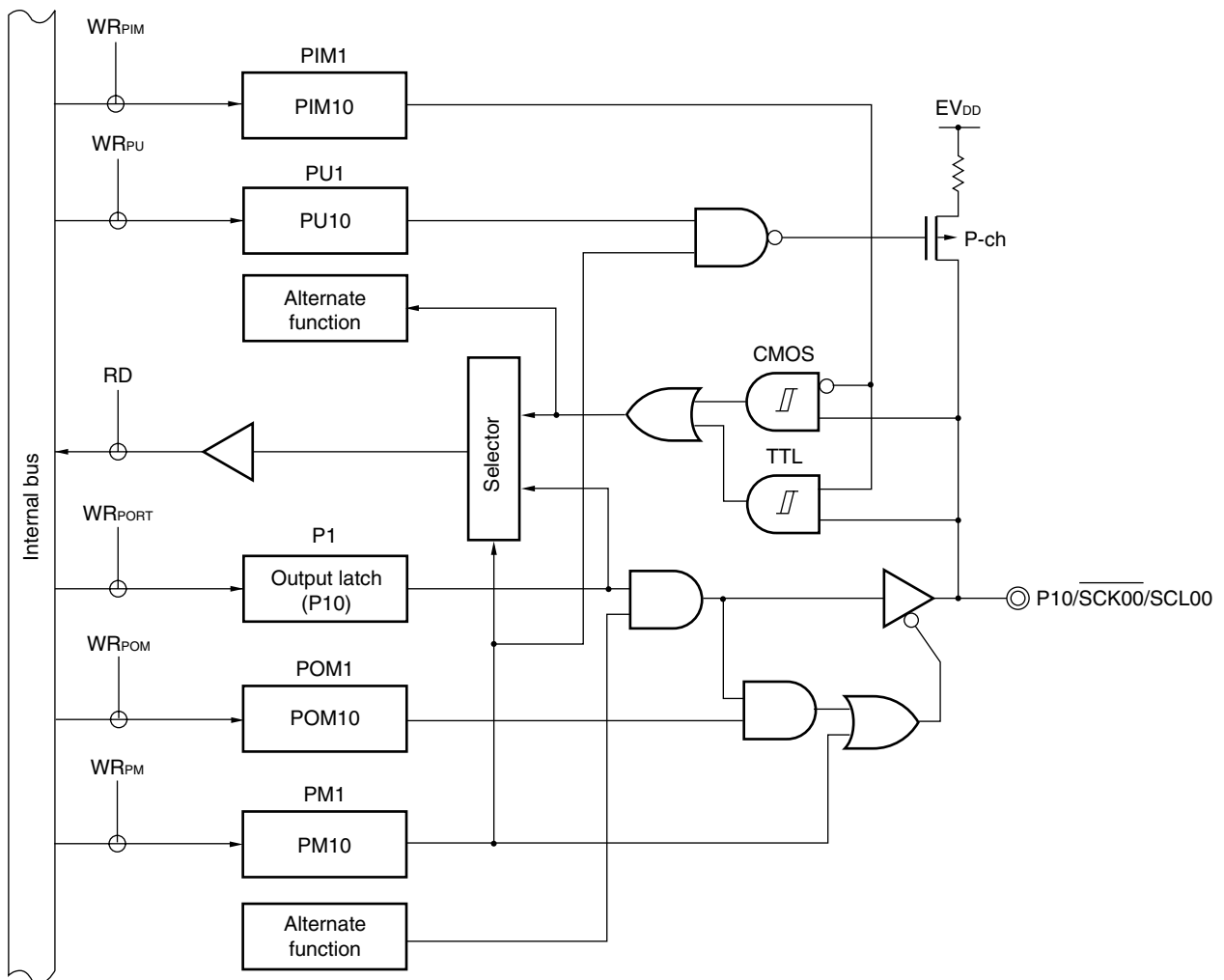
- Notes**
- 52-, 64-, 80-, 100-, 128-pin products only.
  - P10/ $\overline{\text{SCK00}}$ /SCL00, P11/SI00/RxD0/TOOLRxD/SDA00, P12/SO00/TxD0/TOOLTxD, P13/TxD2/SO20, P14/RxD2/SI20/SDA20, or P15/ $\overline{\text{SCK20}}$ /SCL20 as a general-purpose port, set serial channel enable status register m (SEm), serial output register m (SOm) and serial output enable register m (SOEm) to the default status (m = 0, 1).
  - To use P15/PCLBUZ1/SCK20/SCL20 as a general-purpose port in 30- to 52-pin products only, set bit 7 (PCLOE1) of clock output select register 1 (CKS1) to "0", which is the same as their default status setting.
  - To use P16/TI01/TO01/INTP5 or P17/TI02/TO02 as a general-purpose port, set bits 1 and 2 (TO01, TO02) of timer output register 0 (TO0) and bits 1 and 2 (TOE01, TOE02) of timer output enable register 0 (TOE0) to "0", which is the same as their default status setting.
  - To use P16/TI01/TO01/INTP5/SO11 or P17/TI02/TO02/SI11/SDA11 as a general-purpose port in 20-pin products only, set serial channel enable status register 0 (SE0), serial output register 0 (SO0) and serial output enable register 0 (SOE0) to the default status.
  - P17/TI02/TO02/SO11 as a general-purpose port in 24-, 25-pin products only, set serial channel enable status register 0 (SE0), serial output register 0 (SO0) and serial output enable register 0 (SOE0) to the default status.
  - If P10 to P15 are used as general-purpose ports and PIOR0 is set to 1, use the corresponding bits in bits 2 to 7 (TO02 to TO07) of Timer output register 0 (TO0) and bits 2 to 7 (TOE02 to TOE07) of Timer output enable register 0 with "0", which is the same as their initial setting.
  - To use P13 and P14 as a general-purpose port, do not set PIOR2 to 1.
  - If P17 is used as general-purpose port and PIOR1 is set to 1, use Serial channel enable status register 0 (SE0), Serial output register 0 (SO0) and Serial output enable register 0 (SOE0) with the same setting as the initial status.
  - The descriptions in parentheses indicate the case where PIOR<sub>x</sub> = 1.

**Remark**

- ×: don't care
- PM1<sub>x</sub>: Port mode register 1
- PIM1<sub>x</sub>: Port input mode register 1
- POM1<sub>x</sub>: Port output mode register 1
- PMC1<sub>x</sub>: Port mode control register 1
- PIOR<sub>x</sub>: Peripheral I/O redirection register

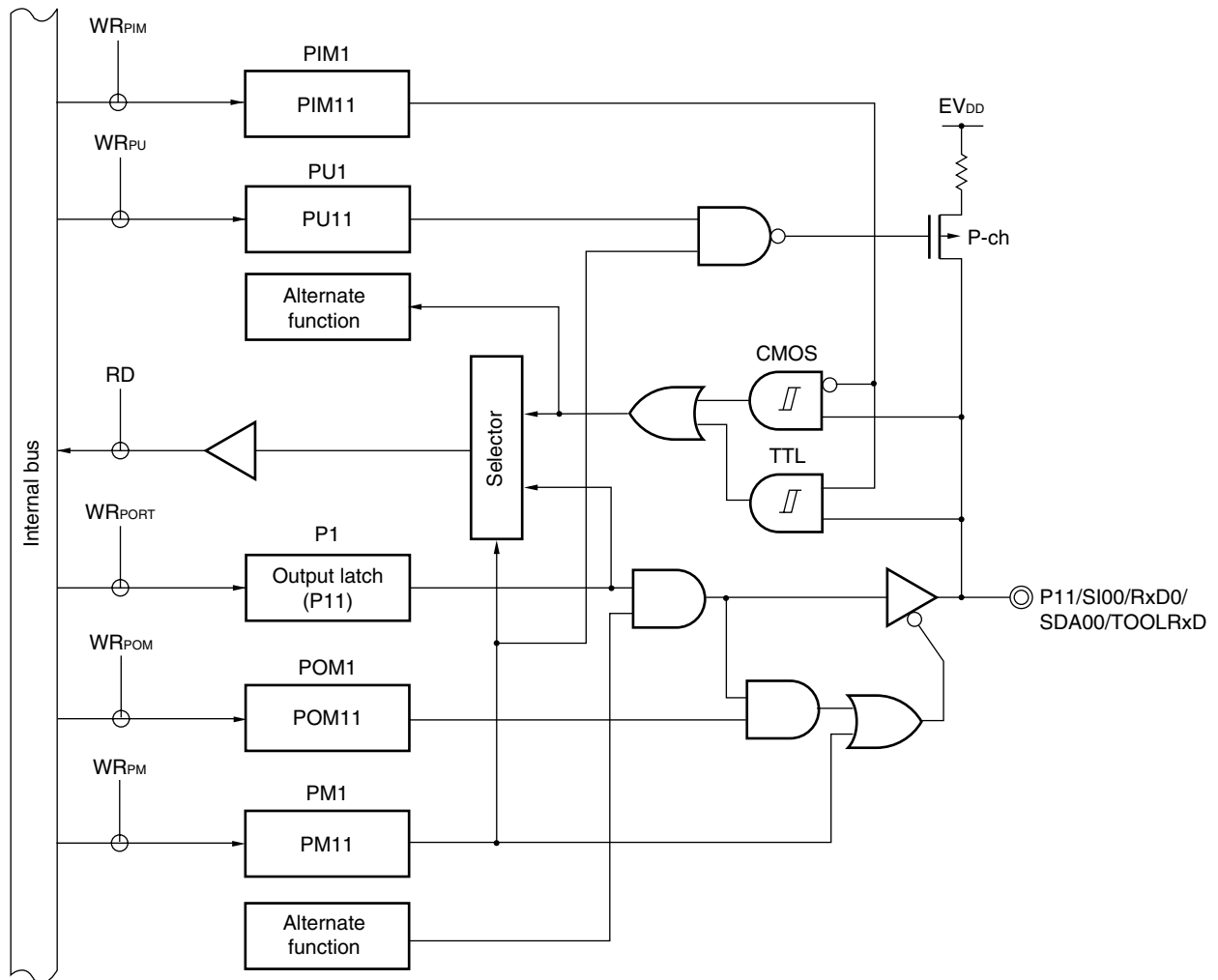
<R> For example, figures 4-7 to 4-14 show block diagrams of port 1 for 128-pin products when PIOR = 00H.

Figure 4-7. Block Diagram of P10



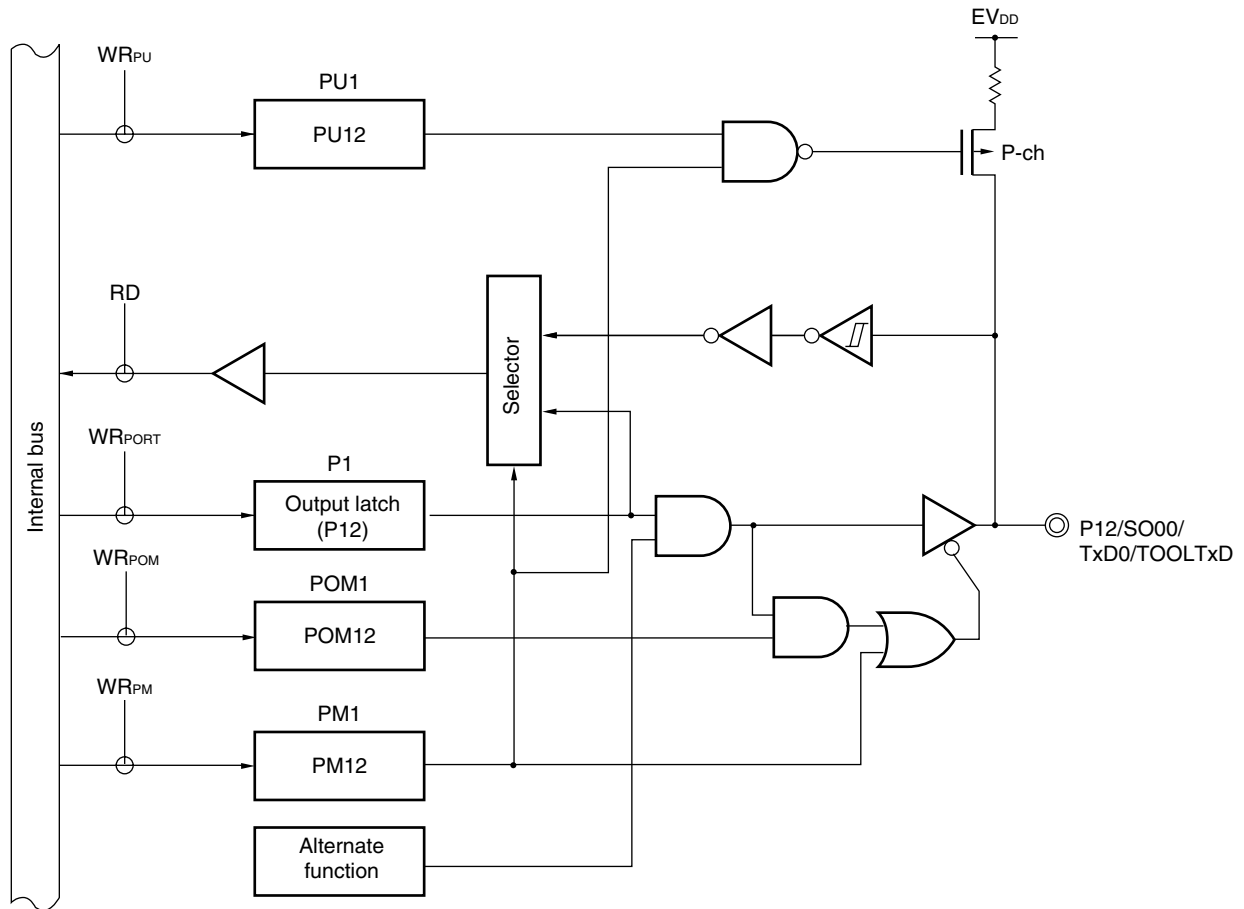
- P1: Port register 1
- PU1: Pull-up resistor option register 1
- PM1: Port mode register 1
- PIM1: Port input mode register 1
- POM1: Port output mode register 1
- RD: Read signal
- WR<sub>xx</sub>: Write signal

Figure 4-8. Block Diagram of P11



- P1: Port register 1
- PU1: Pull-up resistor option register 1
- PM1: Port mode register 1
- PIM1: Port input mode register 1
- POM1: Port output mode register 1
- RD: Read signal
- WR<sub>xx</sub>: Write signal

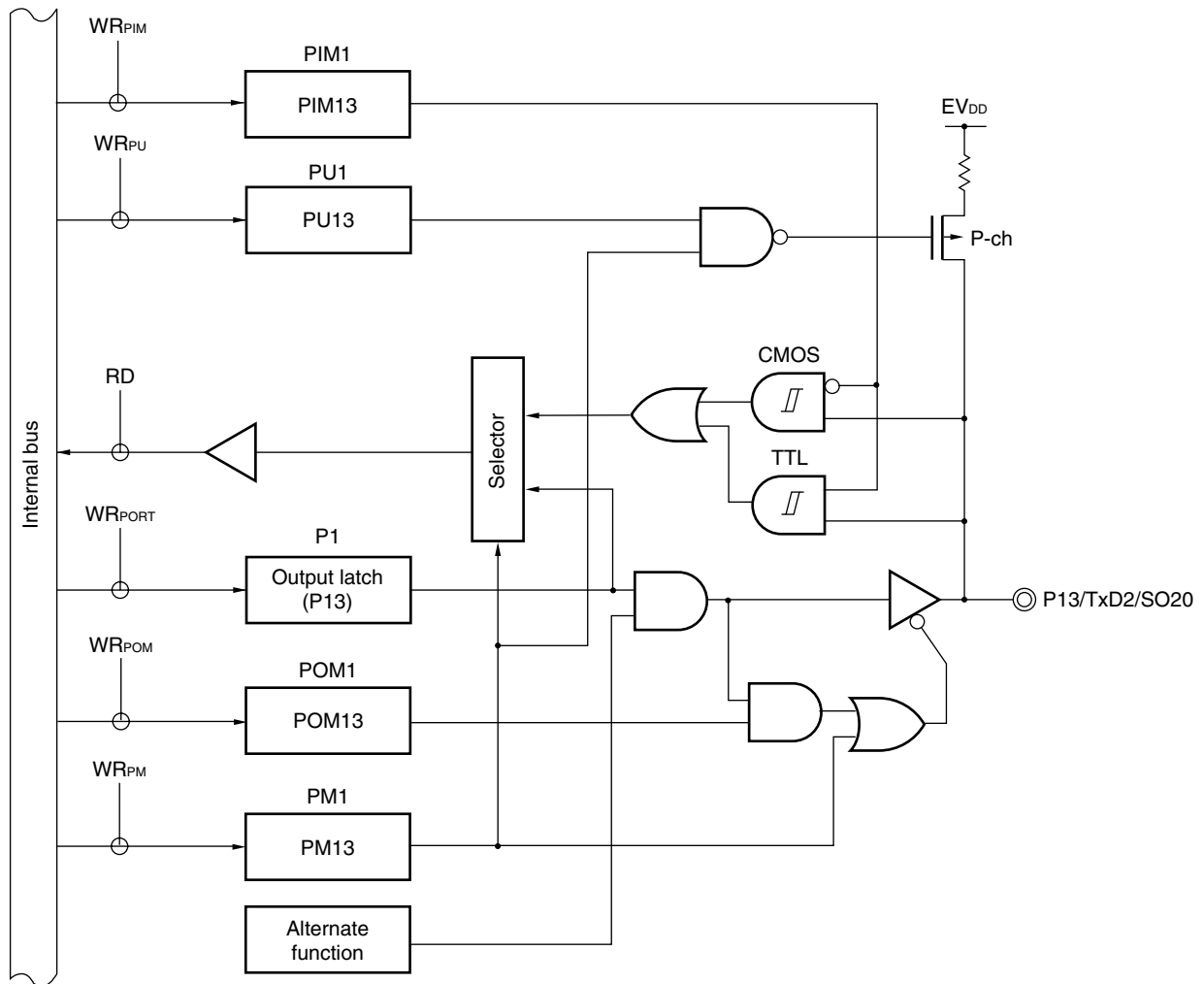
Figure 4-9. Block Diagram of P12



- P1: Port register 1
- PU1: Pull-up resistor option register 1
- PM1: Port mode register 1
- POM1: Port output mode register 1
- RD: Read signal
- WR<sub>xx</sub>: Write signal

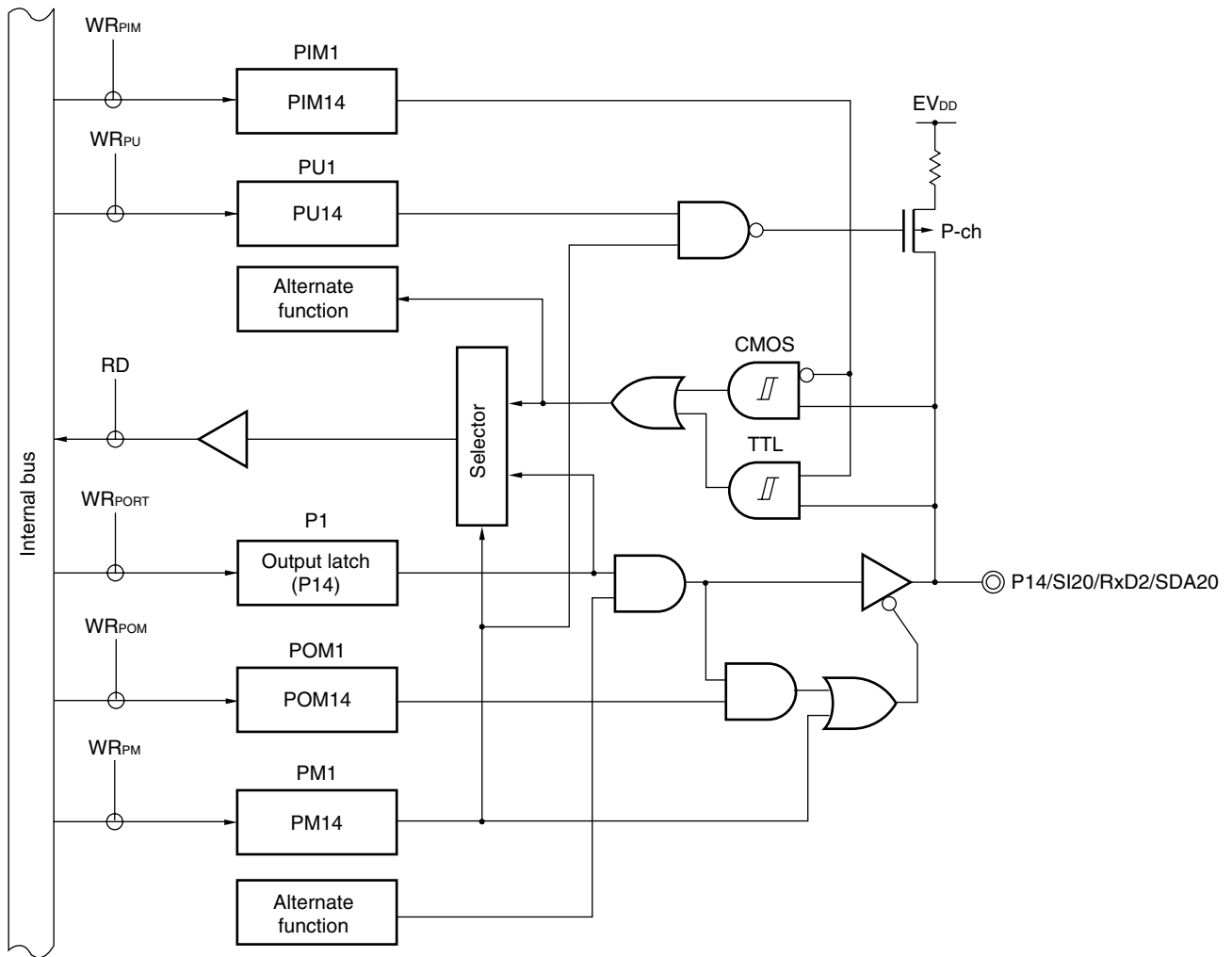
<R>

Figure 4-10. Block Diagram of P13



- P1: Port register 1
- PU1: Pull-up resistor option register 1
- PM1: Port mode register 1
- PIM1: Port input mode register 1
- POM1: Port output mode register 1
- RD: Read signal
- WR<sub>xx</sub>: Write signal

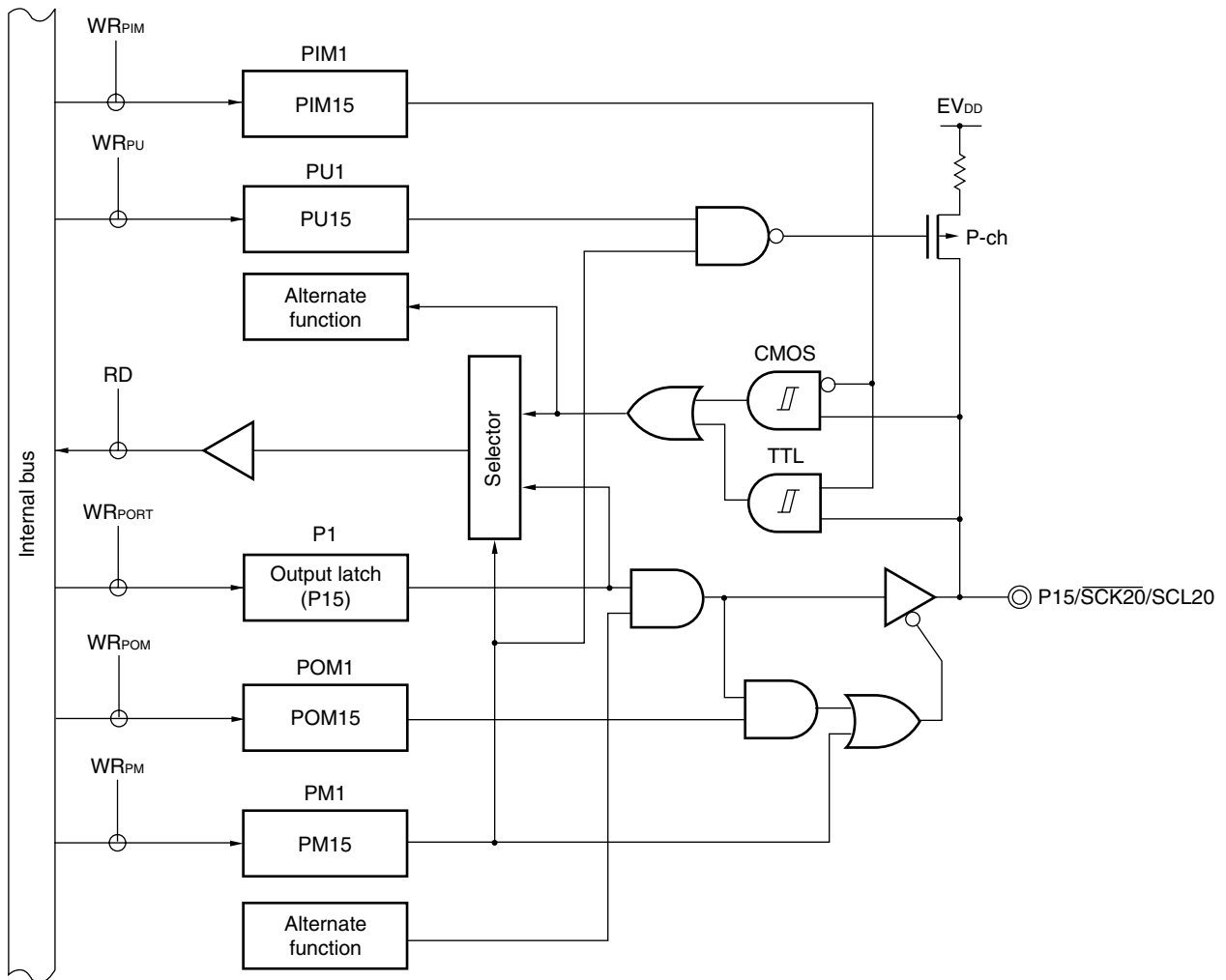
Figure 4-11. Block Diagram of P14



- P1: Port register 1
- PU1: Pull-up resistor option register 1
- PM1: Port mode register 1
- PIM1: Port input mode register 1
- POM1: Port output mode register 1
- RD: Read signal
- WR<sub>xx</sub>: Write signal

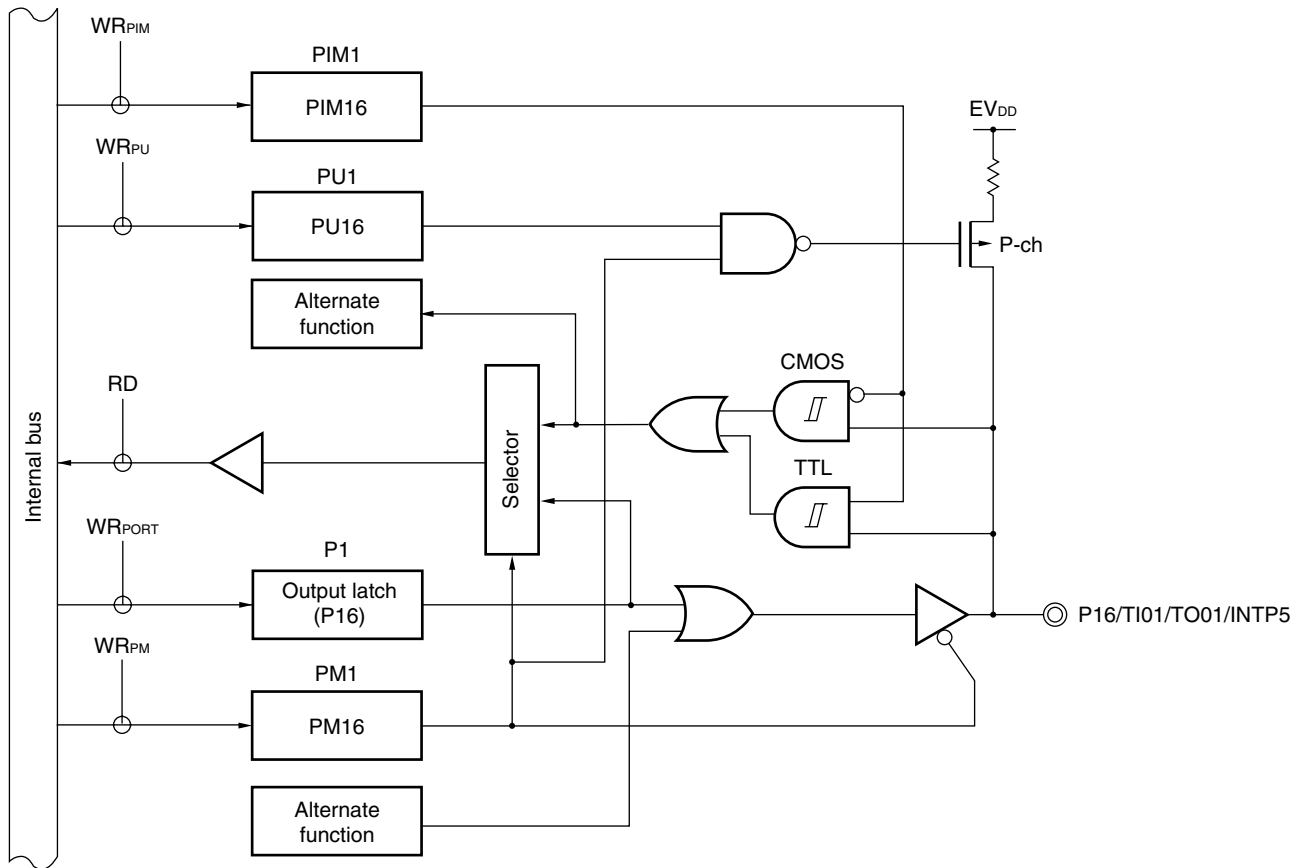


Figure 4-12. Block Diagram of P15



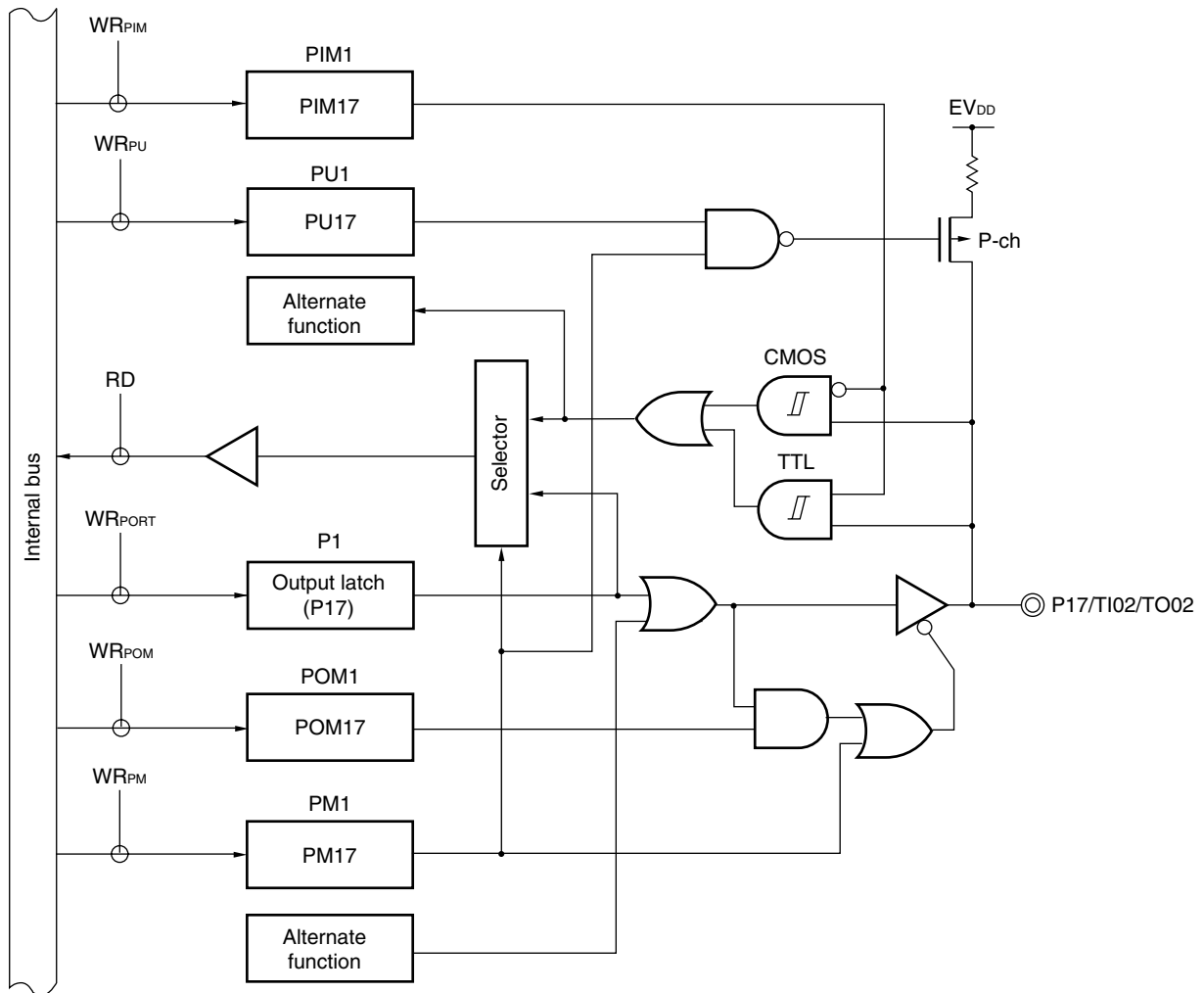
- P1: Port register 1
- PU1: Pull-up resistor option register 1
- PM1: Port mode register 1
- PIM1: Port input mode register 1
- POM1: Port output mode register 1
- RD: Read signal
- WR<sub>xx</sub>: Write signal

Figure 4-13. Block Diagram of P16



- P1: Port register 1
- PU1: Pull-up resistor option register 1
- PM1: Port mode register 1
- PIM1: Port input mode register 1
- RD: Read signal
- WR<sub>xx</sub>: Write signal

Figure 4-14. Block Diagram of P17



- P1: Port register 1
- PU1: Pull-up resistor option register 1
- PM1: Port mode register 1
- PIM1: Port input mode register 1
- POM1: Port output mode register 1
- RD: Read signal
- WR<sub>xx</sub>: Write signal

**4.2.3 Port 2**

Port 2 is an I/O port with an output latch. Port 2 can be set to the input mode or output mode in 1-bit units using port mode register 2 (PM2).

This port can also be used for A/D converter analog input and reference voltage input.

To use P20/ANI0 to P27/ANI7 as digital input pins, set them in the digital I/O mode by using the A/D port configuration register (ADPC) and in the input mode by using the PM2 register. Use these pins starting from the upper bit.

To use P20/ANI0 to P27/ANI7 as digital output pins, set them in the digital I/O mode by using the ADPC register and in the output mode by using the PM2 register.

To use P20/ANI0 to P27/ANI7 as analog input pins, set them in the analog input mode by using the A/D port configuration register (ADPC) and in the input mode by using the PM2 register. Use these pins starting from the lower bit.

<R>

**Table 4-5. Settings of Registers When Using Port 2**

Pin Name		PM2 <sub>x</sub>	ADPC	Alternate Function Setting	Remark
Name	I/O				
P2n	Input	1	01 to n+1H	-	To use P2n as a port, use these pins from a higher bit.
	Output	0	01 to n+1H		

- Remark**
- x: don't care
  - PM2<sub>x</sub>: Port mode register 2
  - ADPC: A/D port configuration register

**Table 4-6. Setting Functions of P20/ANI0 to P27/ANI7 Pins**

ADPC Register	PM2 Register	ADS Register	P20/ANI0 to P27/ANI7 Pins
Digital I/O selection	Input mode	-	Digital input
	Output mode	-	Digital output
Analog input selection	Input mode	Selects ANI.	Analog input (to be converted)
		Does not select ANI.	Analog input (not to be converted)
	Output mode	Selects ANI.	Setting prohibited
		Does not select ANI.	

All P20/ANI0 to P27/ANI7 are set in the analog input mode when the reset signal is generated.



#### 4.2.4 Port 3

Port 3 is an I/O port with an output latch. Port 3 can be set to the input mode or output mode in 1-bit units using port mode register 3 (PM3). When the P30 to P37 pins are used as an input port, use of an on-chip pull-up resistor can be specified in 1-bit units by pull-up resistor option register 3 (PU3).

<R> Input to the P35 to P37 pins can be specified as analog input or digital input in 1-bit units, using port mode control register 3 (PMC3).

This port can also be used for external interrupt request input, real-time clock correction clock output, clock/buzzer output, timer I/O, and A/D converter analog input.

<R> Reset signal generation sets P30 to P34 to input mode, and sets P35 to P37 to analog input.

<R> **Table 4-7. Settings of Registers When Using Port 3**

Pin Name		PM3×	PMC3×	Alternate Function Setting <sup>Note 6</sup>	Remark
Name	I/O				
P30	Input	1	–	×	
	Output	0		RTC1HZ output = 0 <sup>Note 1</sup> SCK11/SCL11 output = 0 <sup>Note 2</sup>	
P31	Input	1	–	×	
	Output	0		TO03 output = 0 <sup>Note 3</sup> PCLBUZ0 output = 0 <sup>Note 4</sup> (PCLBUZ0 output = 0 <sup>Note 5</sup> )	
P32 to P34	Input	1	–	×	
	Output	0		×	
P35 to P37	Input	1	0	×	
	Output	0	0	×	

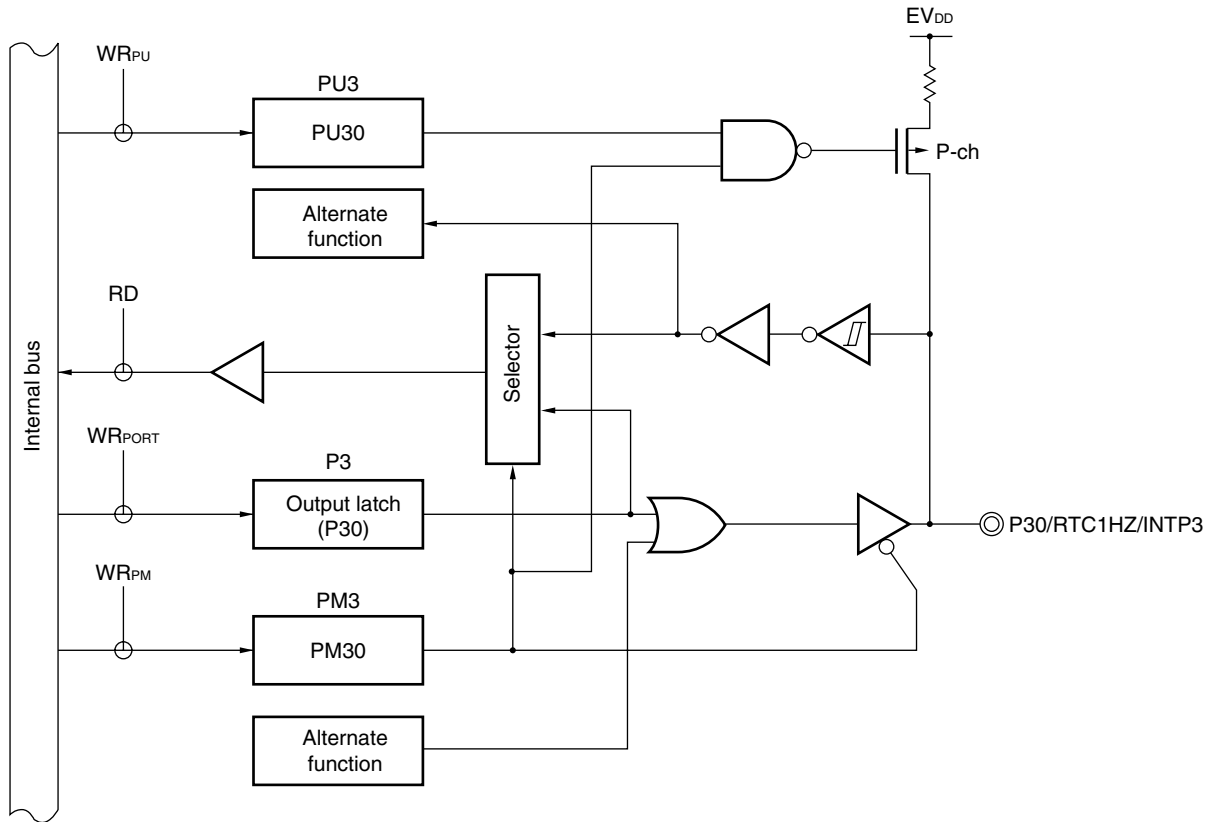
- Notes**
- To use P30/RTC1HZ/INTP3 as a general-purpose port, set bit 5 (RCLOE1) of real-time clock control register 0 (RTCC0) to "0", which is the same as its default status setting.
  - To use P30/INTP3/RTC1HZ/SCK11/SCL11 as a general-purpose port in 20-pin to 100-pin products, set serial channel enable status register 0 (SE0), serial output register 0 (SO0) and serial output enable register 0 (SOE0) to the default status.
  - To use P31/TI03/TO03/INTP4 as a general-purpose port, set bit 3 (TO03) of timer output register 0 (TO0) and bit 3 (TOE03) of timer output enable register 0 (TOE0) to "0", which is the same as their default status setting.
  - To use P31/TI03/TO03/INTP4/PCLBUZ0 as a general-purpose port in 24- to 44-pin products, set bit 7 (PCLOE0) of clock output select register 0 (CKS0) to "0", which is the same as their default status setting.
  - To use P31 as a general-purpose port, do not set PIOR3 set to 1.
  - The descriptions in parentheses indicate the case where PIORx = 1.

**Remark**

- ×: don't care
- PM3×: Port mode register 3
- PMC3×: Port mode control register 3
- PIOR×: Peripheral I/O redirection register

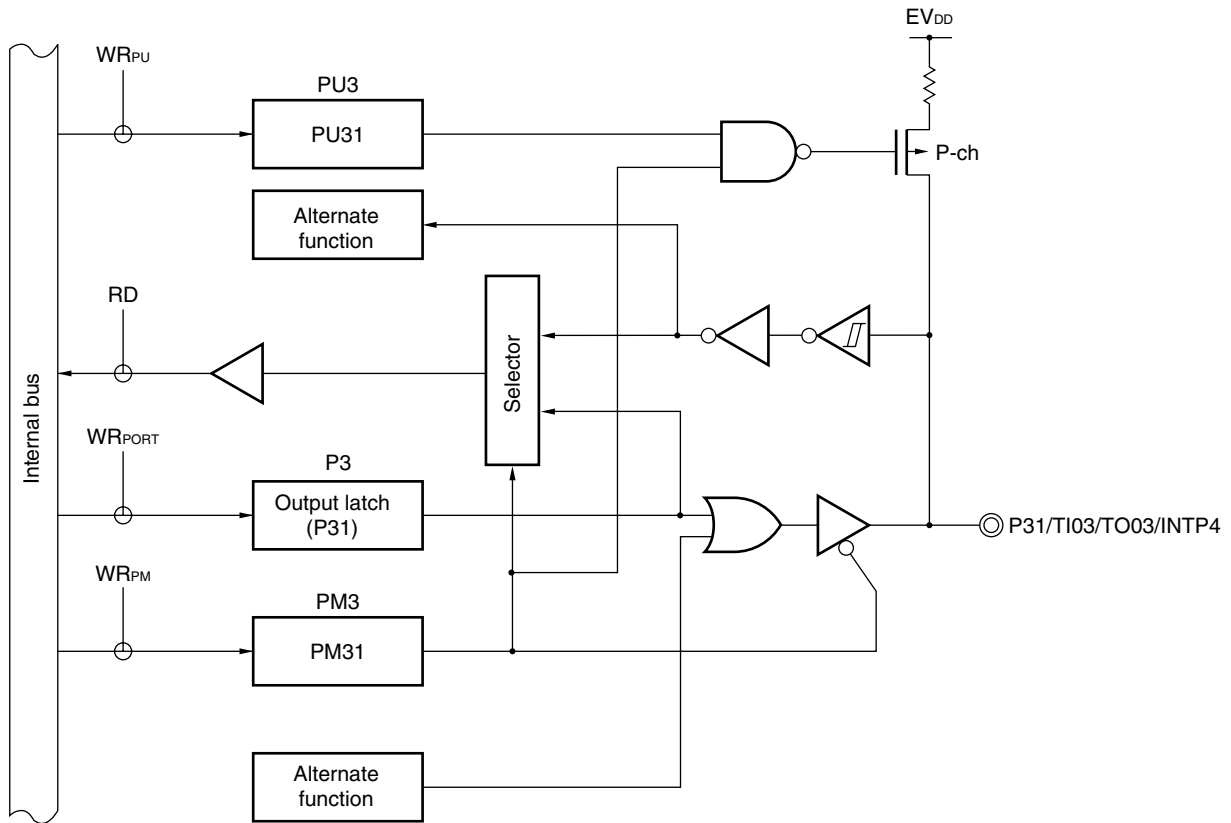
<R> For example, figures 4-16 to 4-19 show block diagrams of port 3 for 128-pin products when PIOR = 00H.

Figure 4-16. Block Diagram of P30



- P3: Port register 3
- PU3: Pull-up resistor option register 3
- PM3: Port mode register 3
- RD: Read signal
- WR<sub>xx</sub>: Write signal

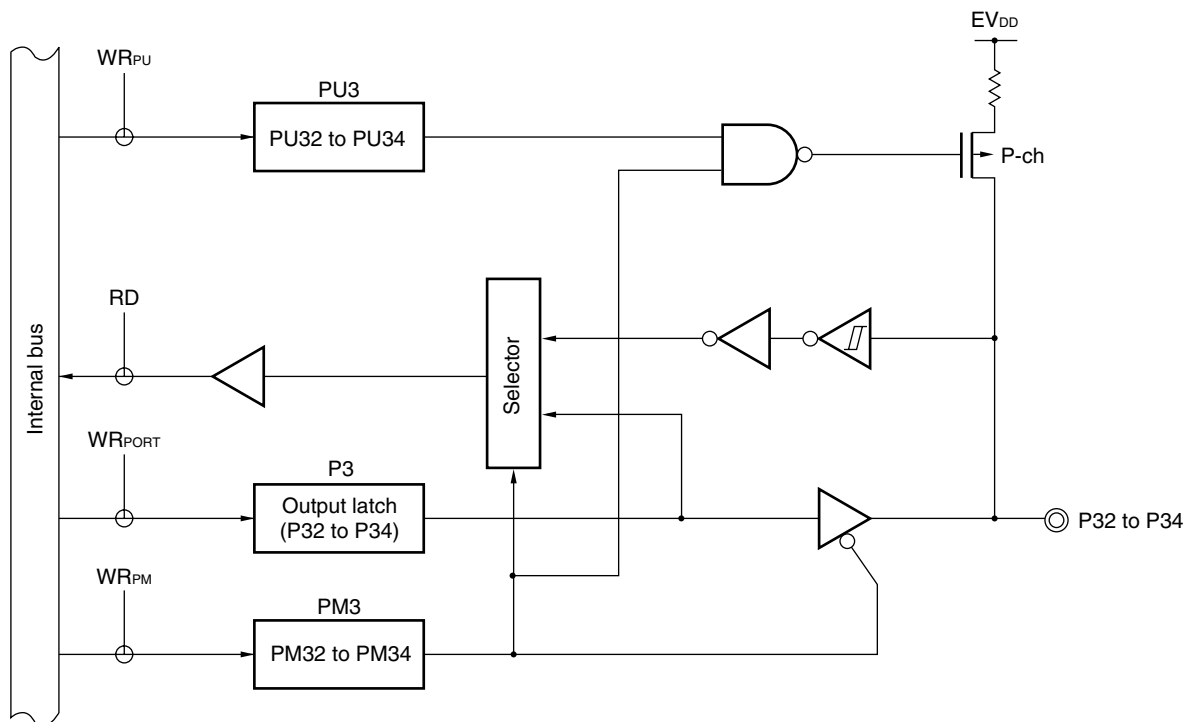
Figure 4-17. Block Diagram of P31



- P3: Port register 3
- PU3: Pull-up resistor option register 3
- PM3: Port mode register 3
- RD: Read signal
- WR<sub>xx</sub>: Write signal

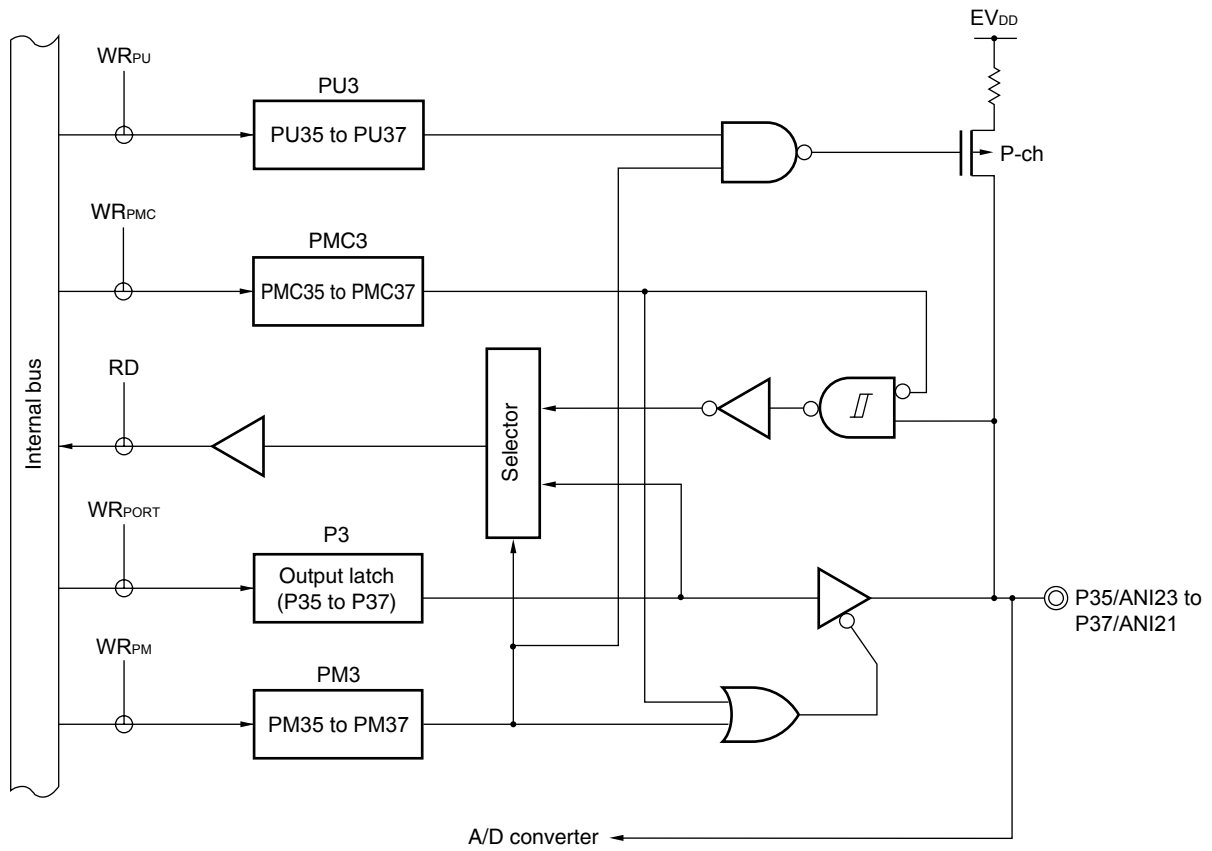


Figure 4-18. Block Diagram of P32 to P34



- P3: Port register 3
- PU3: Pull-up resistor option register 3
- PM3: Port mode register 3
- RD: Read signal
- WR<sub>xx</sub>: Write signal

Figure 4-19. Block Diagram of P35 to P37



- P3: Port register 3
- PU3: Pull-up resistor option register 3
- PM3: Port mode register 3
- PMC3: Port mode control register 3
- RD: Read signal
- WR<sub>xx</sub>: Write signal

#### 4.2.5 Port 4

Port 4 is an I/O port with an output latch. Port 4 can be set to the input mode or output mode in 1-bit units using port mode register 4 (PM4). When the P40 to P47 pins are used as an input port, use of an on-chip pull-up resistor can be specified in 1-bit units by pull-up resistor option register 4 (PU4).

Input to the P43 and P44 pins can be specified through a normal input buffer or a TTL input buffer in 1-bit units using port input mode register 4 (PIM4).

Output from the P430 to P45 pins can be specified as N-ch open-drain output ( $V_{DD}$  tolerance) in 1-bit units using port output mode register 4 (POM4).

This port can also be used for data I/O for a flash memory programmer/debugger, timer I/O, serial interface data I/O, clock I/O, and external interrupt request input.

Reset signal generation sets port 4 to input mode.

&lt;R&gt;

Table 4-8. Settings of Registers When Using Port 4

Pin Name		PM4×	PIM4×	POM4×	Alternate Function Setting	Remark
Name	I/O					
P40	Input	1	–	–	×	
	Output	0			×	
P41	Input	1	–	–	×	
	Output	0			TO07 output = 0 <sup>Note 1</sup>	
P42	Input	1	–	–	×	
	Output	0			TO04 output = 0 <sup>Note 2</sup>	
P43	Input	1	0	×	×	CMOS input
		1	1	×	×	TTL input
	Output	0	×	0	SCK01/SCL01 output = 1 <sup>Note 3</sup>	CMOS output
		0	×	1		N-ch O.D. output
P44	Input	1	0	×	×	CMOS input
		1	1	×	×	TTL input
	Output	0	×	0	SDA01 output = 1 <sup>Note 3</sup>	CMOS output
		0	×	1		N-ch O.D. output
P45	Input	1	–	×	×	
	Output	0		0	SO01 output = 1 <sup>Note 3</sup>	CMOS output
		0		1		N-ch O.D. output
P46	Input	1	–	–	×	
	Output	0			TO05 output = 0 <sup>Note 2</sup>	
P47	Input	1	–	–	×	
	Output	0			×	

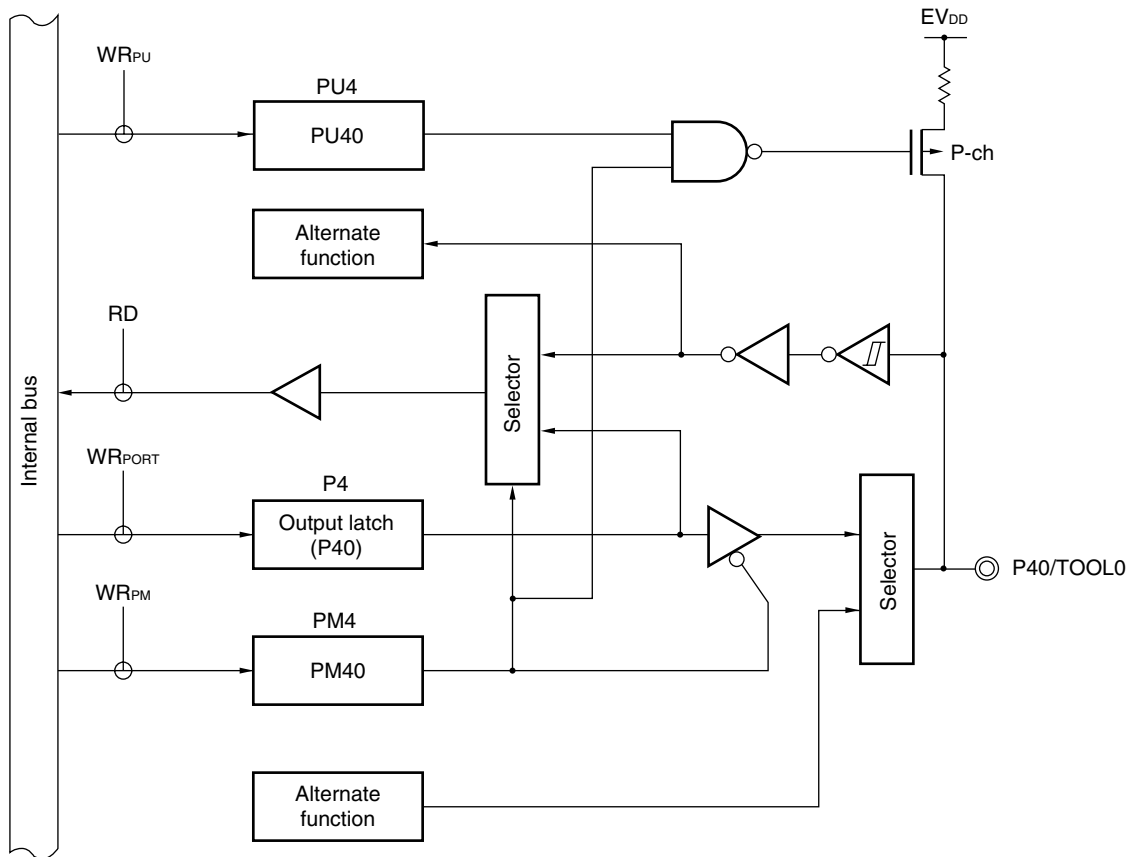
- Notes 1.** P41/TI07/TO07 as a general-purpose port in 44- to 80-pin products, set bit 7 (TO07) of timer output register 0 (TO0) and bit 7 (TOE07) of timer output enable register 7 (TOE7) to “0”, which is the same as their default status setting.
- 2.** To use P42/TI04/TO04 or P46/INTP1/TI05/TO05 as a general-purpose port, set bits 4 and 5 (TO04, TO05) of timer output register 0 (TO0) and bits 4 and 5 (TOE04, TOE05) of timer output enable register 0 (TOE0) to “0”, which is the same as their default status setting.
- 3.** P43/SCK01/SCL01, P44/SI01/SDA01, P45/SO01 as a general-purpose port, set serial channel enable status register 0 (SE0), serial output register 0 (SO0) and serial output enable register 0 (SOE0) to the default status.

**Caution** When a tool is connected, the P40 pin cannot be used as a port pin.

**Remark** ×: don't care  
 PM4×: Port mode register 4  
 PIM4×: Port input mode register 4  
 POM4×: Port output mode register 4

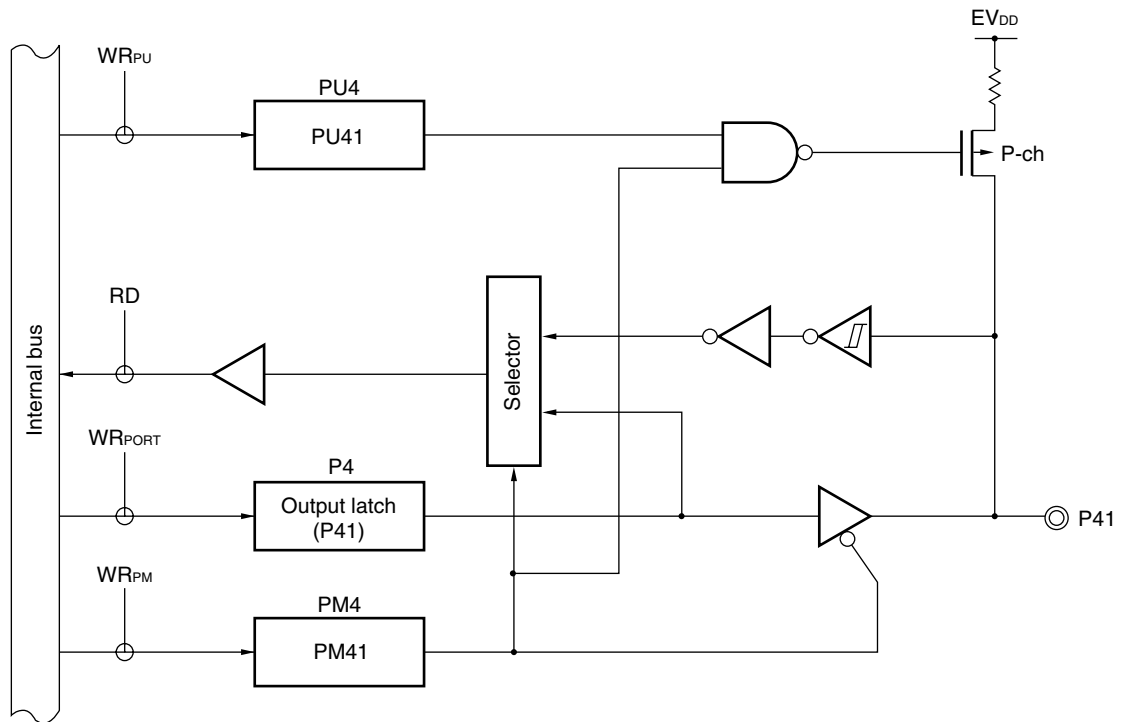
<R> For example, figures 4-20 to 4-26 show block diagrams of port 4 for 128-pin products when PIOR = 00H.

Figure 4-20. Block Diagram of P40



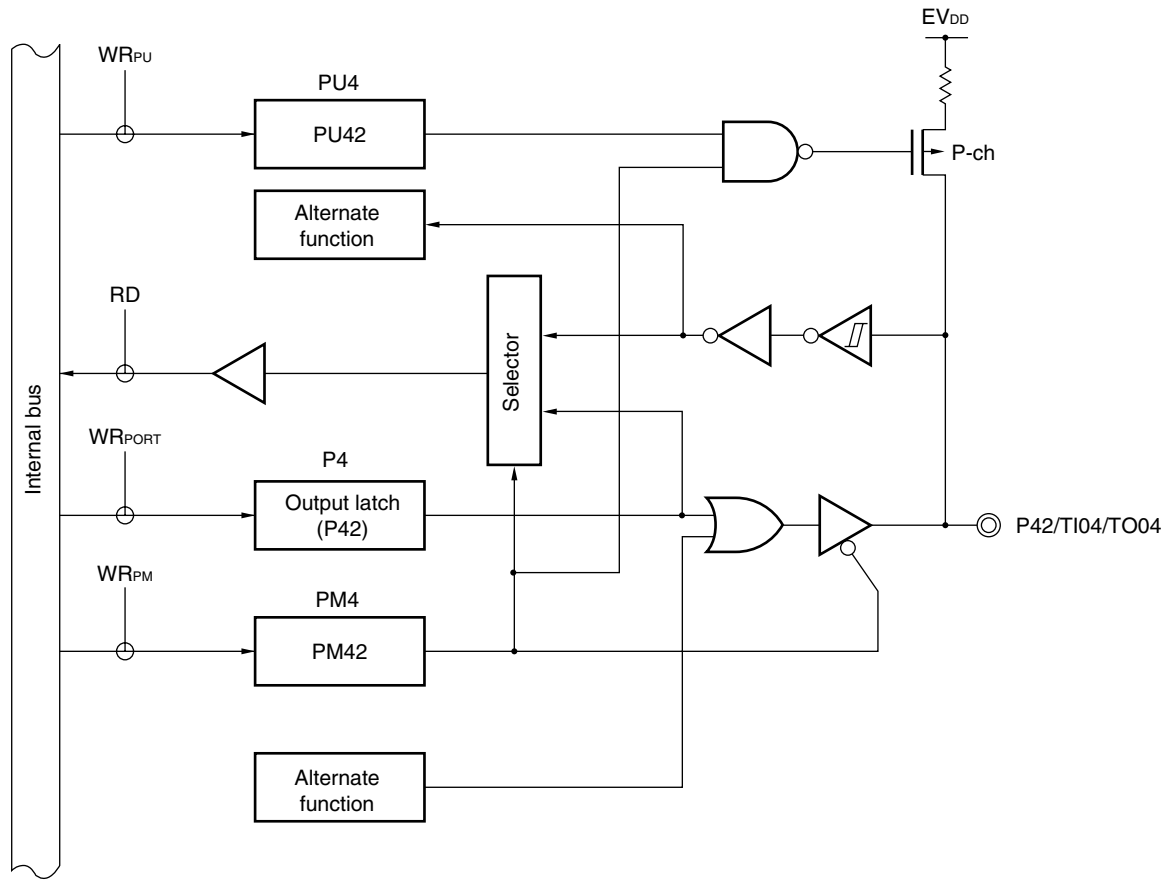
- P4: Port register 4
- PU4: Pull-up resistor option register 4
- PM4: Port mode register 4
- RD: Read signal
- WR<sub>xx</sub>: Write signal

Figure 4-21. Block Diagram of P41



- P4: Port register 4
- PU4: Pull-up resistor option register 4
- PM4: Port mode register 4
- RD: Read signal
- $WR_{xx}$ : Write signal

Figure 4-22. Block Diagram of P42

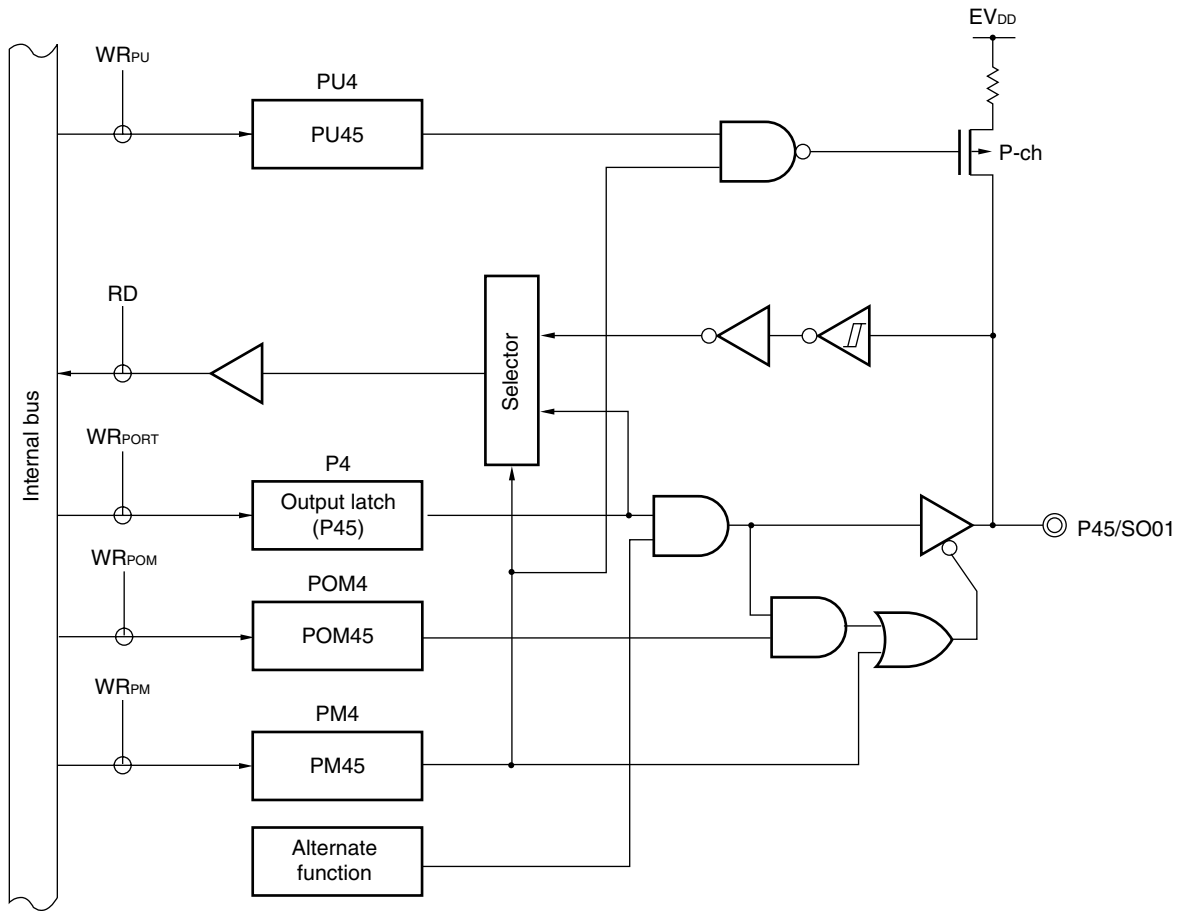


- P4: Port register 4
- PU4: Pull-up resistor option register 4
- PM4: Port mode register 4
- RD: Read signal
- WR<sub>xx</sub>: Write signal





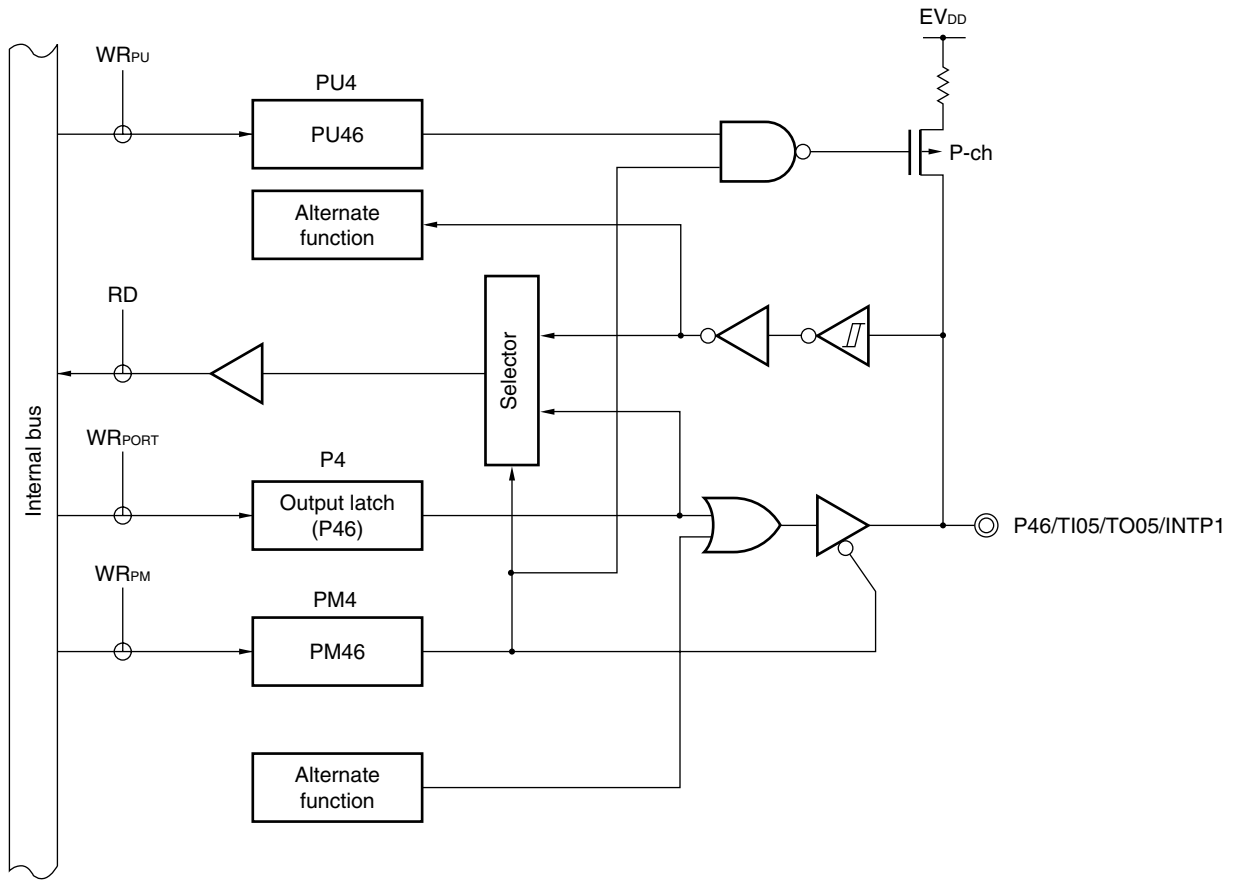
Figure 4-24. Block Diagram of P45



- P4: Port register 4
- PU4: Pull-up resistor option register 4
- PM4: Port mode register 4
- POM4: Port output mode register 4
- RD: Read signal
- WR<sub>xx</sub>: Write signal

<R>

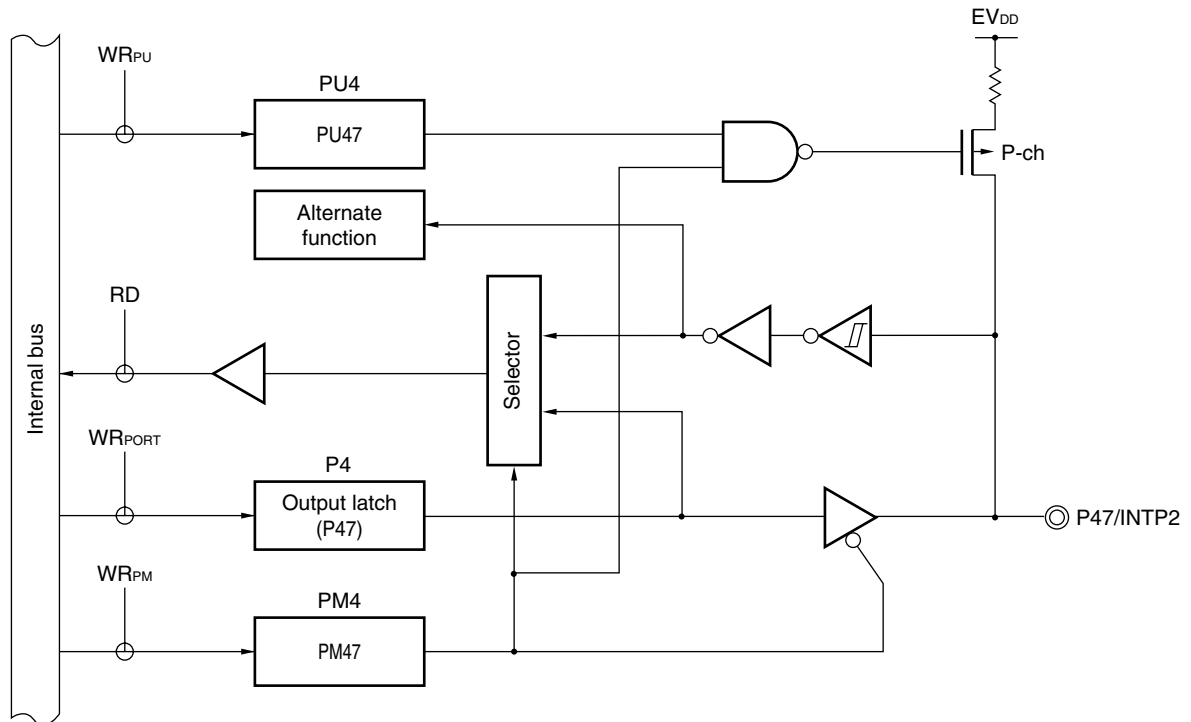
Figure 4-25. Block Diagram of P46



- P4: Port register 4
- PU4: Pull-up resistor option register 4
- PM4: Port mode register 4
- RD: Read signal
- WR<sub>xx</sub>: Write signal

<R>

Figure 4-26. Block Diagram of P47



- P4: Port register 4
- PU4: Pull-up resistor option register 4
- PM4: Port mode register 4
- RD: Read signal
- WR<sub>xx</sub>: Write signal

#### 4.2.6 Port 5

Port 5 is an I/O port with an output latch. Port 5 can be set to the input mode or output mode in 1-bit units using port mode register 5 (PM5). When the P50 to P57 pins are used as an input port, use of an on-chip pull-up resistor can be specified in 1-bit units by pull-up resistor option register 5 (PU5).

Input to the P53 to P55 pins can be specified through a normal input buffer or a TTL input buffer in 1-bit units using port input mode register 5 (PIM5).

Output from the P50, and P52 to P55 pin can be specified as N-ch open-drain output ( $V_{DD}$  tolerance) in 1-bit units using port output mode register 5 (POM5).

This port can also be used for serial interface data I/O, clock I/O.

Reset signal generation sets port 5 to input mode.

&lt;R&gt;

Table 4-9. Settings of Registers When Using Port 5

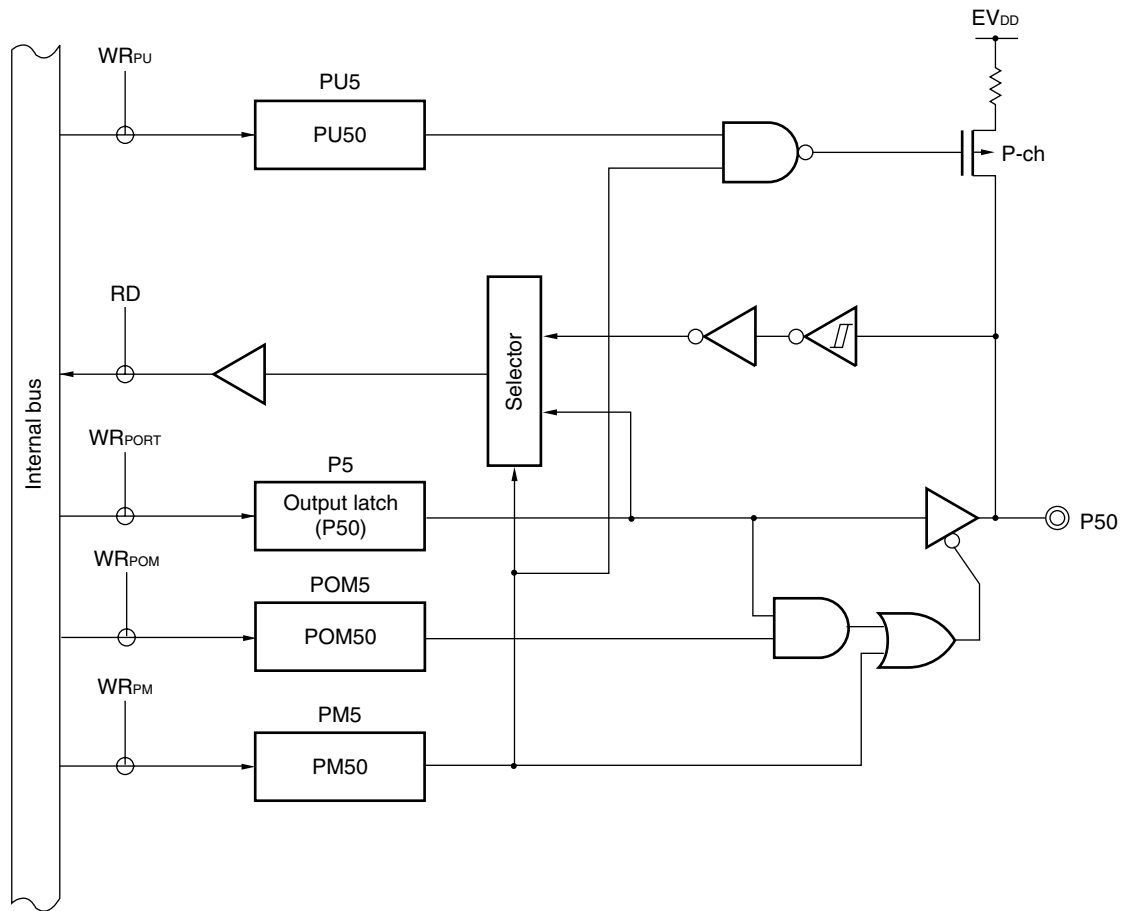
Pin Name		PM5×	PIM5×	POM5×	Alternate Function Setting <sup>Note 5</sup>	Remark
Name	I/O					
P50	Input	1	–	×	×	
	Output	0		0	SDA11 output = 1 <sup>Note 1</sup>	CMOS output
		0		1		N-ch O.D. output
P51	Input	1	–	–	×	
	Output	0			SO11 output = 1 <sup>Note 1</sup>	
P52	Input	1	–	×	×	
	Output	0		0	SO31 output = 1 <sup>Note 2</sup>	CMOS output
		0		1		N-ch O.D. output
P53	Input	1	0	×	×	CMOS input
		1	1	×	×	TTL input
	Output	0	×	0	SDA31 output = 1 <sup>Note 2</sup>	CMOS output
		0	×	1		N-ch O.D. output
P54	Input	1	0	×	×	CMOS input
		1	1	×	×	TTL input
	Output	0	×	0	SCK31/SCL31 output = 1 <sup>Note 1</sup>	CMOS output
		0	×	1		N-ch O.D. output
P55	Input	1	0	×	×	CMOS input
		1	1	×	×	TTL input
	Output	0	×	0	(SCK00 output = 1 <sup>Note 3</sup> ) (PCLBUZ1 output = 0 <sup>Note 4</sup> )	CMOS output
		0	×	1		N-ch O.D. output
P56, P57	Input	1	–	–	–	
	Output	0				

- Notes 1.** To use P50 as a general-purpose port in 24- to 100-pin products or to use P51 as a general-purpose port in 30- to 100-pin products, set serial channel enable status register 0 (SE0), serial output register 0 (SO0) and serial output enable register 0 (SOE0) to the default status.
- 2.** P52/SO31, P53/SI31/SDA31, P54/SCK31/SCL31 as a general-purpose port, set serial channel enable status register 1 (SE1), serial output register 1 (SO1) and serial output enable register 1 (SOE1) to the default status.
- 3.** To use P55 as a general-purpose port when PIOR1 = 1, set serial channel enable status register 0 (SE0), serial output register 0 (SO0) and serial output enable register 0 (SOE0) to the default status.
- 4.** To use P55 as a general-purpose port when PIOR4 = 1, set clock output select registers 1 (CKS1) to the default status.
- 5.** The descriptions in parentheses indicate the case where PIORx = 1.

**Remark** ×: don't care  
 PM5×: Port mode register 5  
 PIM5×: Port input mode register 5  
 POM5×: Port output mode register 5  
 PIOR×: Peripheral I/O redirection register

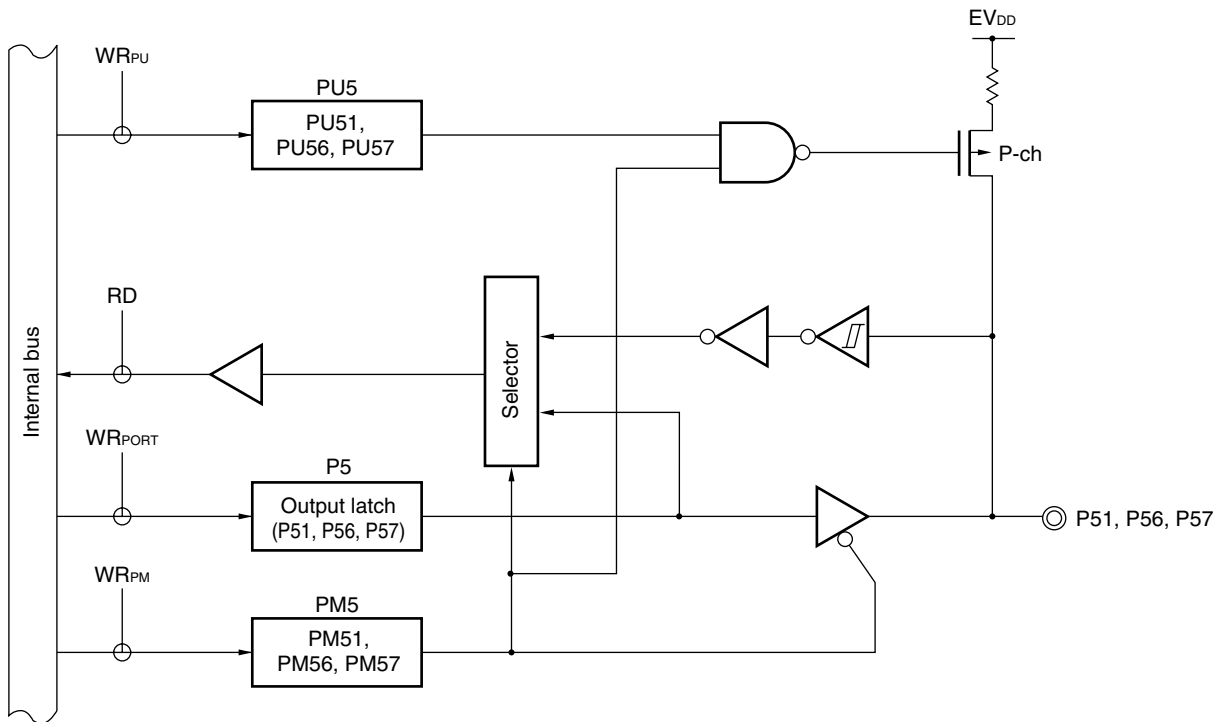
<R> For example, figures 4-27 to 4-31 show block diagrams of port 5 for 128-pin products when PIOR = 00H.

Figure 4-27. Block Diagram of P50



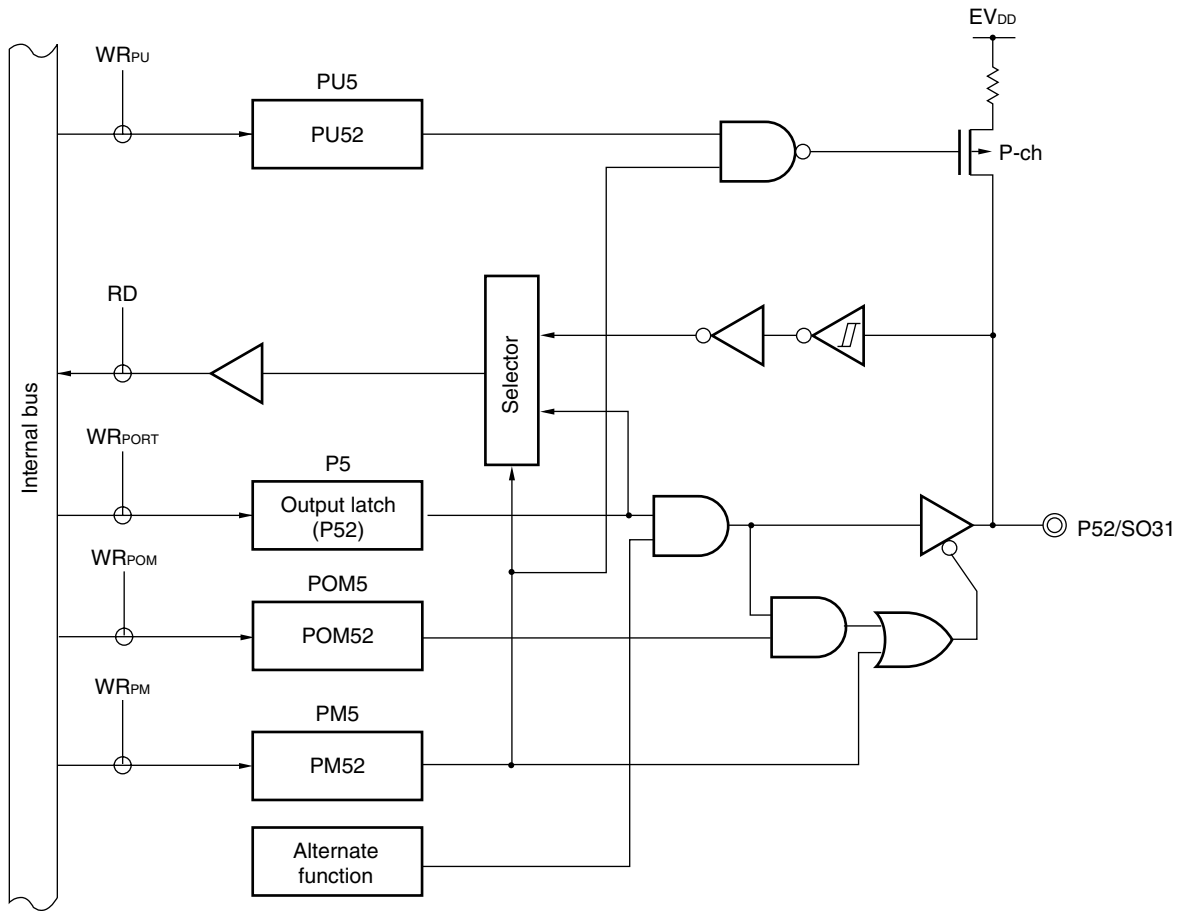
- P5: Port register 5
- PU5: Pull-up resistor option register 5
- PM5: Port mode register 5
- POM5: Port output mode register 5
- RD: Read signal
- WR<sub>xx</sub>: Write signal

Figure 4-28. Block Diagram of P51, P56, P57



- P5: Port register 5
- PU5: Pull-up resistor option register 5
- PM5: Port mode register 5
- RD: Read signal
- WR<sub>xx</sub>: Write signal

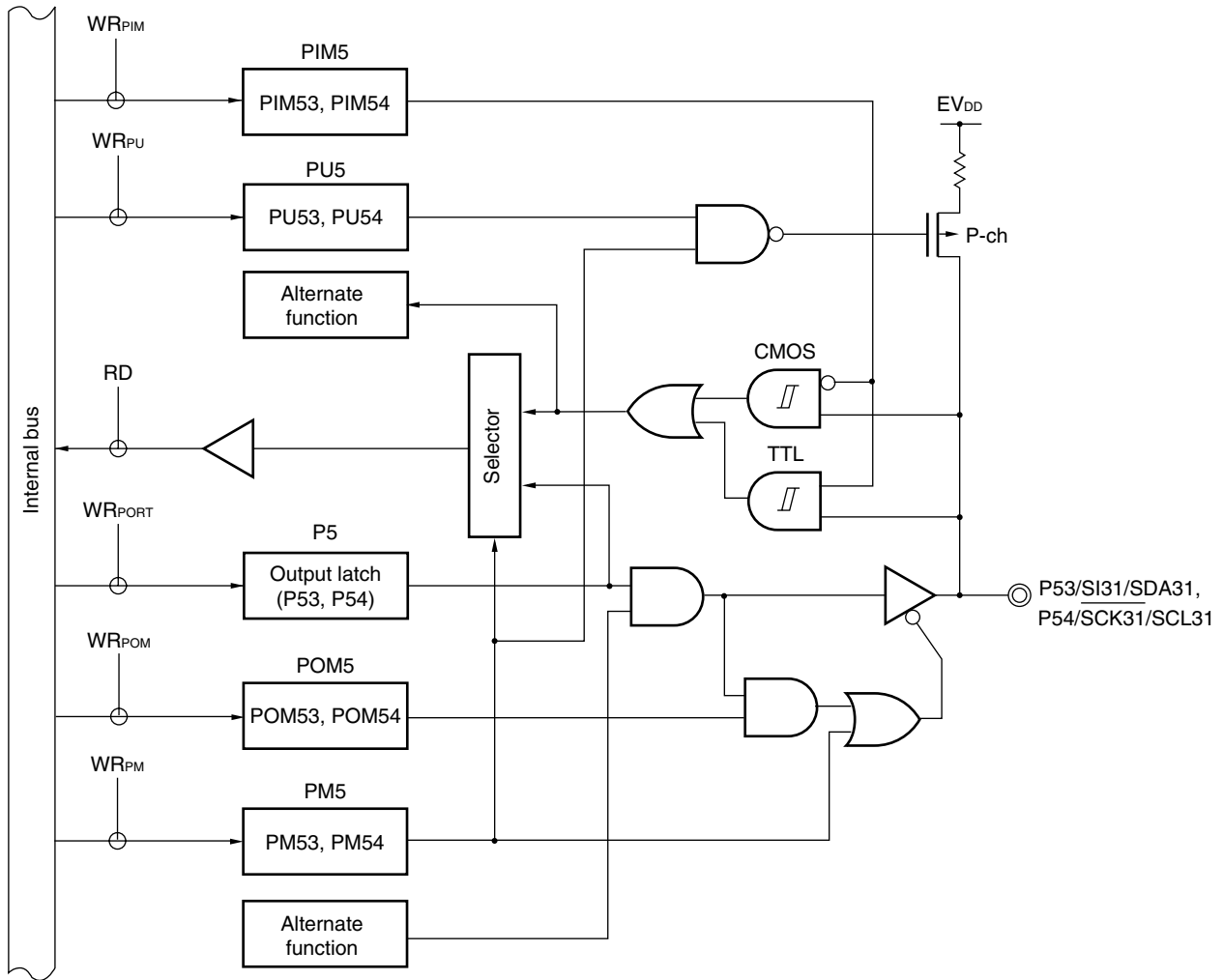
Figure 4-29. Block Diagram of P52



- P5: Port register 5
- PU5: Pull-up resistor option register 5
- PM5: Port mode register 5
- POM5: Port output mode register 5
- RD: Read signal
- WR<sub>xx</sub>: Write signal

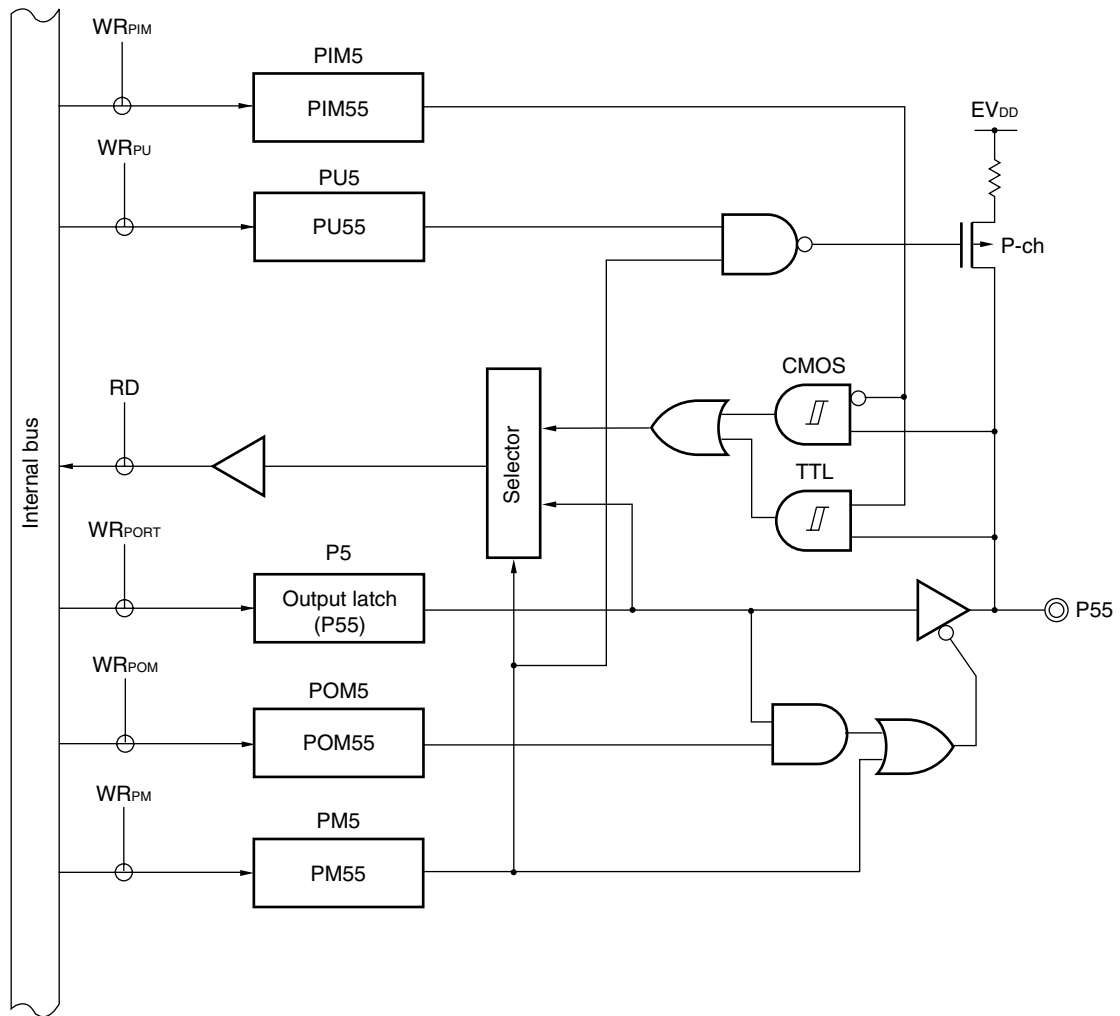


Figure 4-30. Block Diagram of P53, P54



- P5: Port register 5
- PU5: Pull-up resistor option register 5
- PM5: Port mode register 5
- PIM5: Port input mode register 5
- POM5: Port output mode register 5
- RD: Read signal
- WR<sub>xx</sub>: Write signal

Figure 4-31. Block Diagram of P55



- P5: Port register 5
- PU5: Pull-up resistor option register 5
- PM5: Port mode register 5
- PIM5: Port input mode register 5
- POM5: Port output mode register 5
- RD: Read signal
- WR<sub>xx</sub>: Write signal

#### 4.2.7 Port 6

Port 6 is an I/O port with an output latch. Port 6 can be set to the input mode or output mode in 1-bit units using port mode register 6 (PM6). When the P64 to P67 pins are used as an input port, use of an on-chip pull-up resistor can be specified in 1-bit units by pull-up resistor option register 6 (PU6).

The output of the P60 to P63 pins is N-ch open-drain output (6 V tolerance).

This port can also be used for serial interface data I/O and clock I/O, and timer I/O.

Reset signal generation sets port 6 to input mode.

<R>

**Table 4-10. Settings of Registers When Using Port 6**

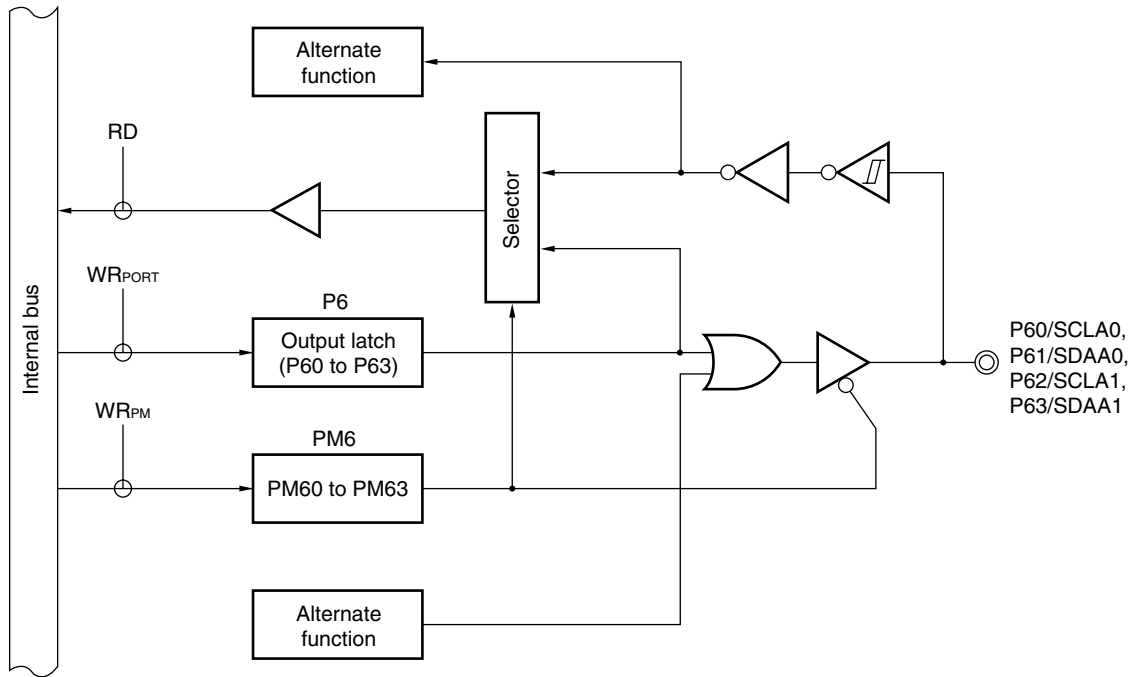
Pin Name		PM6×	Alternate Function Setting	Remark
Name	I/O			
P60	Input	1	SCLA0 output = 0 <sup>Note 2</sup>	
	Output	0		
P61	Input	1	SDAA0 output = 0 <sup>Note 2</sup>	
	Output	0		
P62	Input	1	SCLA1 output = 0 <sup>Note 2</sup>	
	Output	0		
P63	Input	1	SDAA1 output = 0 <sup>Note 2</sup>	
	Output	0		
P64	Input	1	TO10 output = 0 <sup>Note 2</sup>	
	Output	0		
P65	Input	1	TO11 output = 0 <sup>Note 2</sup>	
	Output	0		
P66	Input	1	TO12 output = 0 <sup>Note 2</sup>	
	Output	0		
P67	Input	1	TO13 output = 0 <sup>Note 2</sup>	
	Output	0		

- Notes**
1. Stop the operation of serial interface IICA when using P60/SCLA0, P61/SDAA0, P62/SCLA1, and P63/SDAA1 as general-purpose ports.
  2. To use P64/TI10/TO10 to P67/TI13/TO13 as a general-purpose port, set bits 0 to 3 (TO10 to TO13) of timer output register 1 (TO1) and bits 0 to 3 (TOE10 to TOE13) of timer output enable register 1 (TOE1) to "0", which is the same as their default status setting.

**Remark** ×: don't care  
 PM6×: Port mode register 6

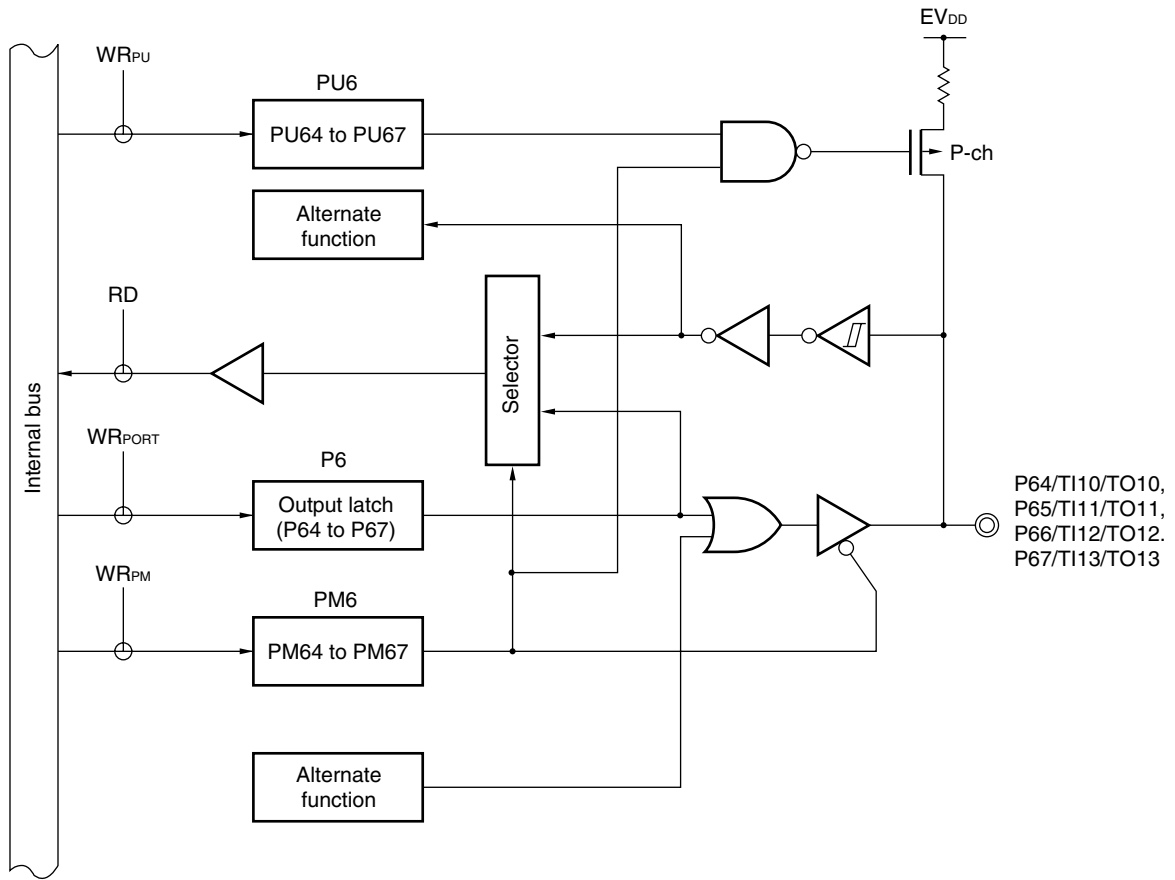
<R> For example, figures 4-32 and 4-33 show block diagrams of port 6 for 128-pin products when PIOR = 00H

Figure 4-32. Block Diagram of P60 to P63



- P6: Port register 6
- PM6: Port mode register 6
- RD: Read signal
- WR<sub>xx</sub>: Write signal

Figure 4-33. Block Diagram of P64 to P67



- P6: Port register 6
- PU6: Pull-up resistor option register 6
- PM6: Port mode register 6
- RD: Read signal
- WR<sub>xx</sub>: Write signal

#### 4.2.8 Port 7

Port 7 is an I/O port with an output latch. Port 7 can be set to the input mode or output mode in 1-bit units using port mode register 7 (PM7). When used as an input port, use of an on-chip pull-up resistor can be specified in 1-bit units by pull-up resistor option register 7 (PU7).

Output from the P71 and P74 pins can be specified as N-ch open-drain output ( $V_{DD}$  tolerance) in 1-bit units using port output mode register 7 (POM7).

This port can also be used for key interrupt input, serial interface data I/O, clock I/O, and external interrupt request input. Reset signal generation sets port 7 to input mode.

&lt;R&gt;

Table 4-11. Settings of Registers When Using Port 7

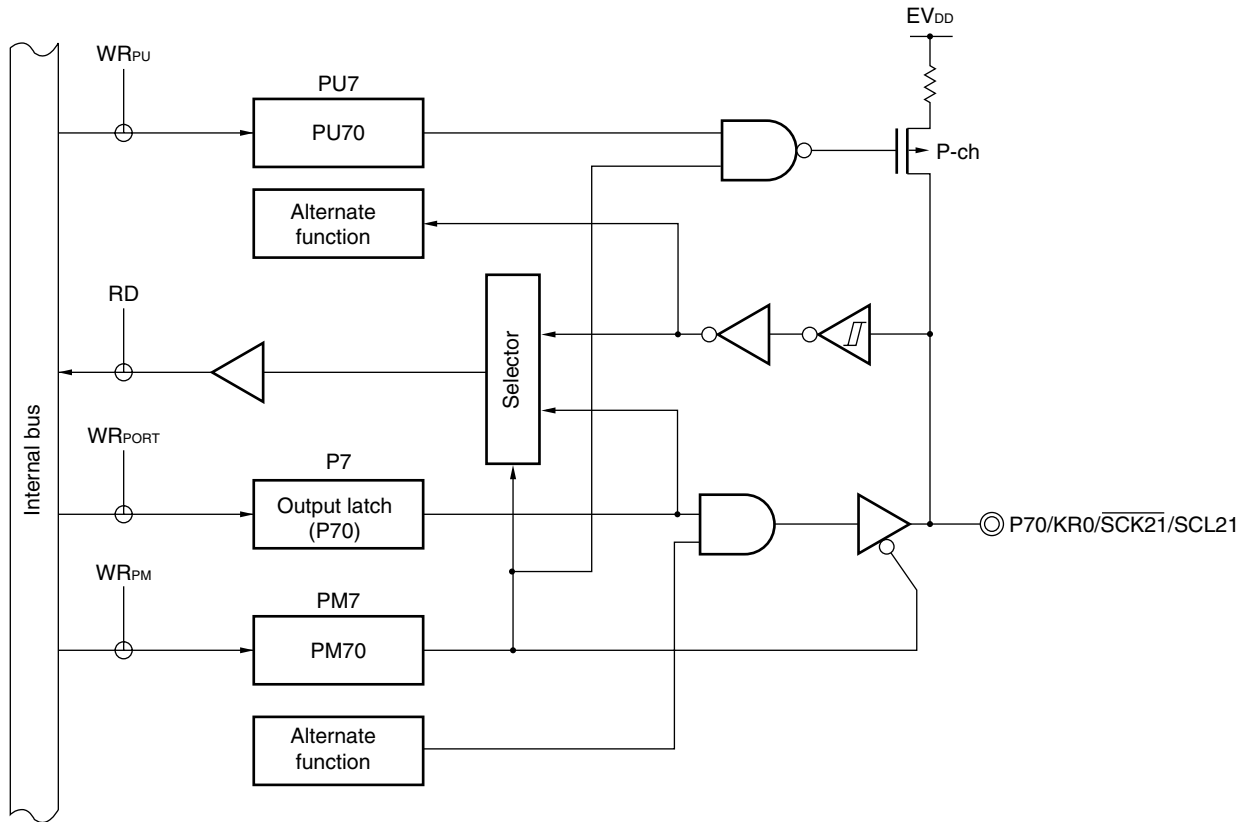
Pin Name		PM7 <sub>x</sub>	POM7 <sub>x</sub>	Alternate Function Setting <sup>Note 4</sup>	Remark
Name	I/O				
P70	Input	1	–	x	
	Output	0		SCK21/SCL21 output = 1 <sup>Note 1</sup>	
P71	Input	1	x	x	
	Output	0	0	SDA21 output = 1 <sup>Note 1</sup>	CMOS output
		0	1		N-ch O.D. output
P72	Input	1	–	x	
	Output	0		SO21 output = 1 <sup>Note 1</sup>	
P73	Input	1	–	x	
	Output	0		SO01 output = 1 <sup>Note 2</sup>	
P74	Input	1	x	x	
	Output	0	0	SDA01 output = 1 <sup>Note 2</sup>	CMOS output
		0	1		N-ch O.D. output
P75	Input	1	–	x	
	Output	0		SCK01/SCL01 output = 1 <sup>Note 2</sup>	
P76	Input	1	–	x	
	Output	0		x	
P77	Input	1	–	x	
	Output	0		(TxD2 output = 1 <sup>Note 3</sup> )	

- Notes 1.** To use P70/KR0/SCK21/SCL21, P71/KR1/SI21/SDA21 or P72/KR2/SO21 as a general-purpose port, set serial channel enable status register 1 (SE1), serial output register 1 (SO1) and serial output enable register 1 (SOE1) to the default status.
- 2.** To use P73 to P75 as a general-purpose port in 48- to 64-pin products, set serial channel enable status register 0 (SE0), serial output register 0 (SO0) and serial output enable register 0 (SOE0) to the default status.
- 3.** To use P55 as a general-purpose port when PIOR1 = 1, set serial channel enable status register 1 (SE1), serial output register 1 (SO1) and serial output enable register 1 (SOE1) to the default status.
- 4.** The descriptions in parentheses indicate the case where PIOR<sub>x</sub> = 1.

**Remark** x: don't care  
 PM7<sub>x</sub>: Port mode register 7  
 POM7<sub>x</sub>: Port output mode register 7  
 PIOR<sub>x</sub>: Peripheral I/O redirection register

<R> For example, figures 4-34 to 4-38 show block diagrams of port 7 for 128-pin products when PIOR = 00H.

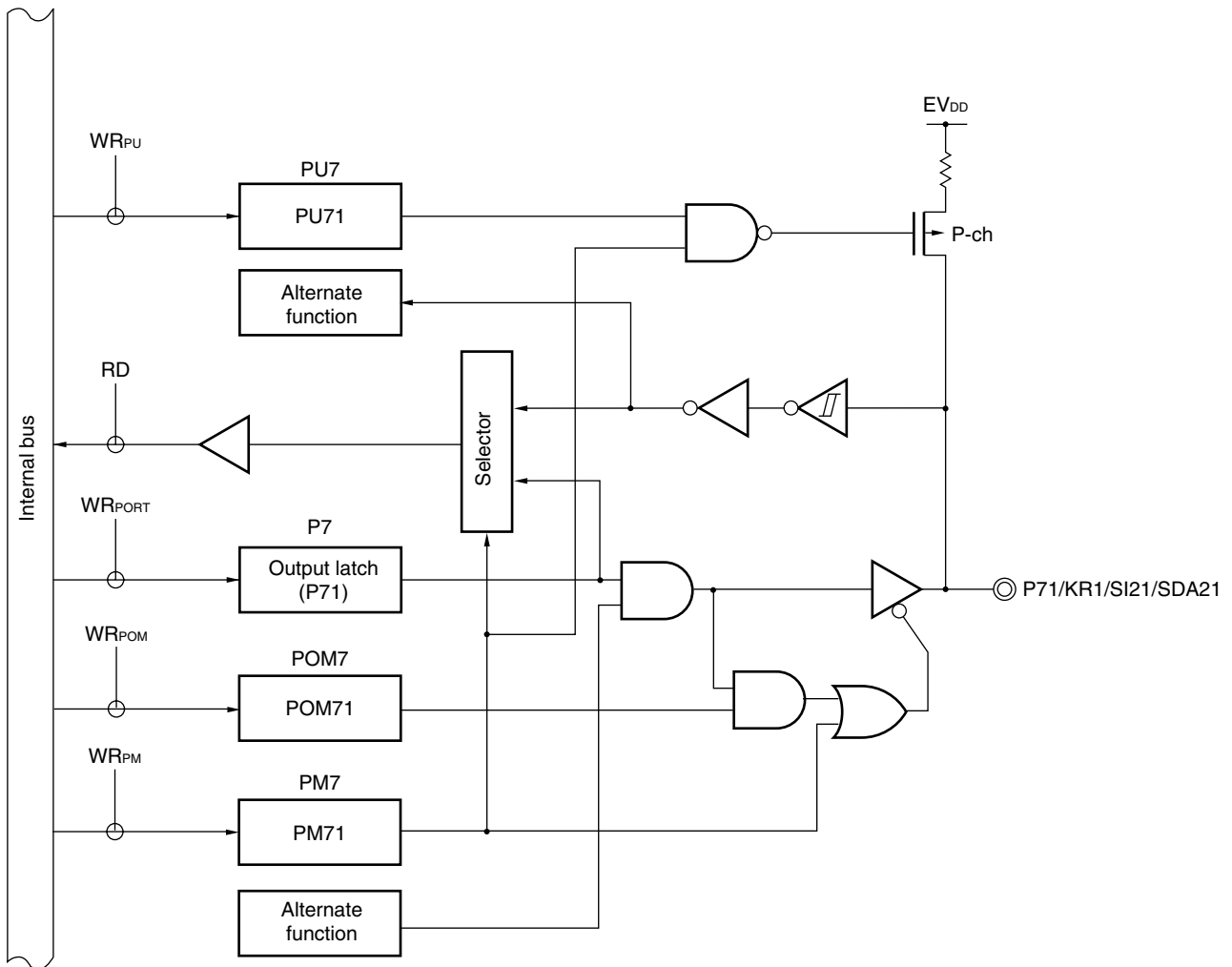
Figure 4-34. Block Diagram of P70



- P7: Port register 7
- PU7: Pull-up resistor option register 7
- PM7: Port mode register 7
- RD: Read signal
- WR<sub>xx</sub>: Write signal

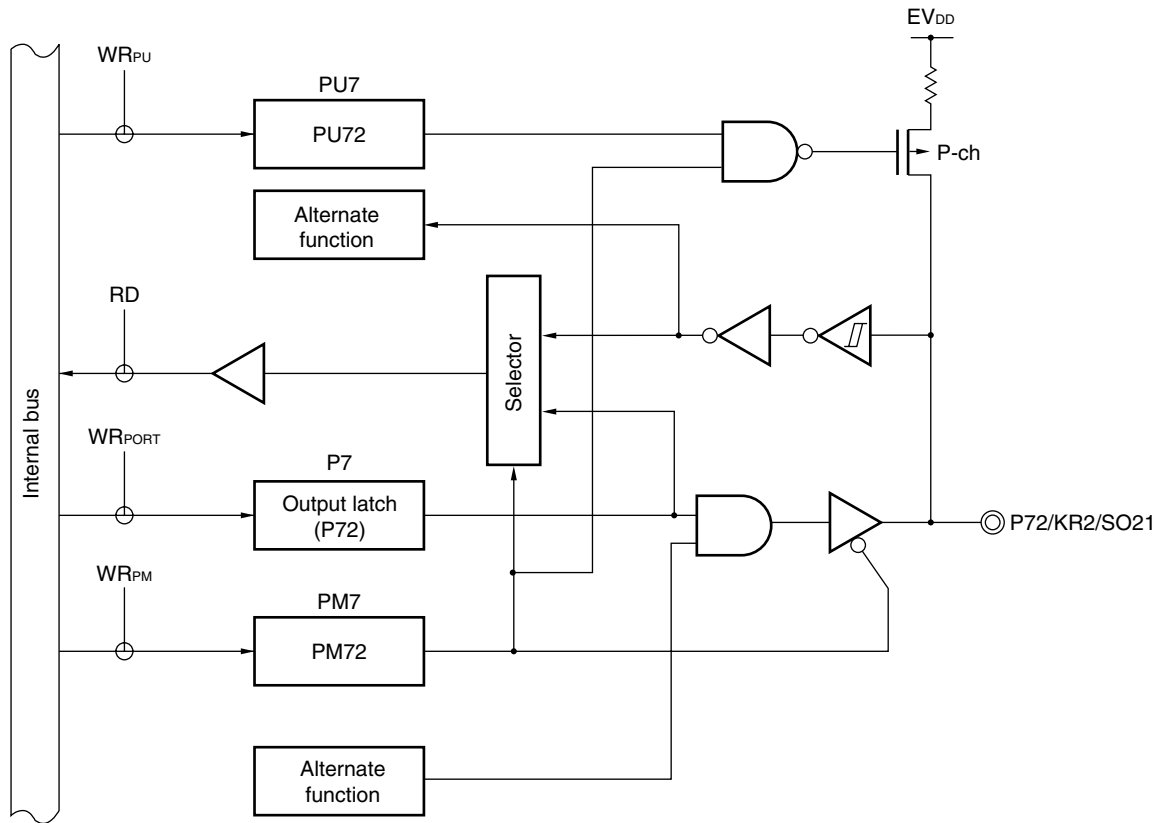


Figure 4-35. Block Diagram of P71



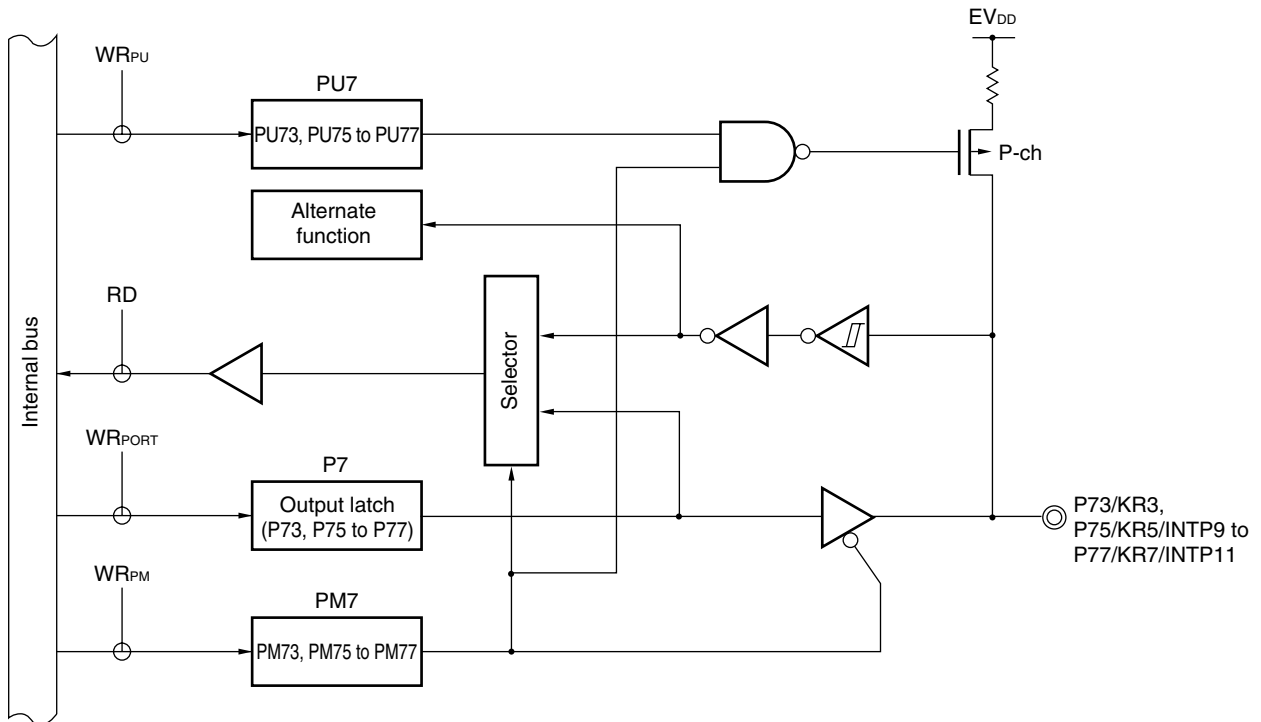
- P7: Port register 7
- PU7: Pull-up resistor option register 7
- PM7: Port mode register 7
- POM7: Port output mode register 7
- RD: Read signal
- WR<sub>xx</sub>: Write signal

Figure 4-36. Block Diagram of P72



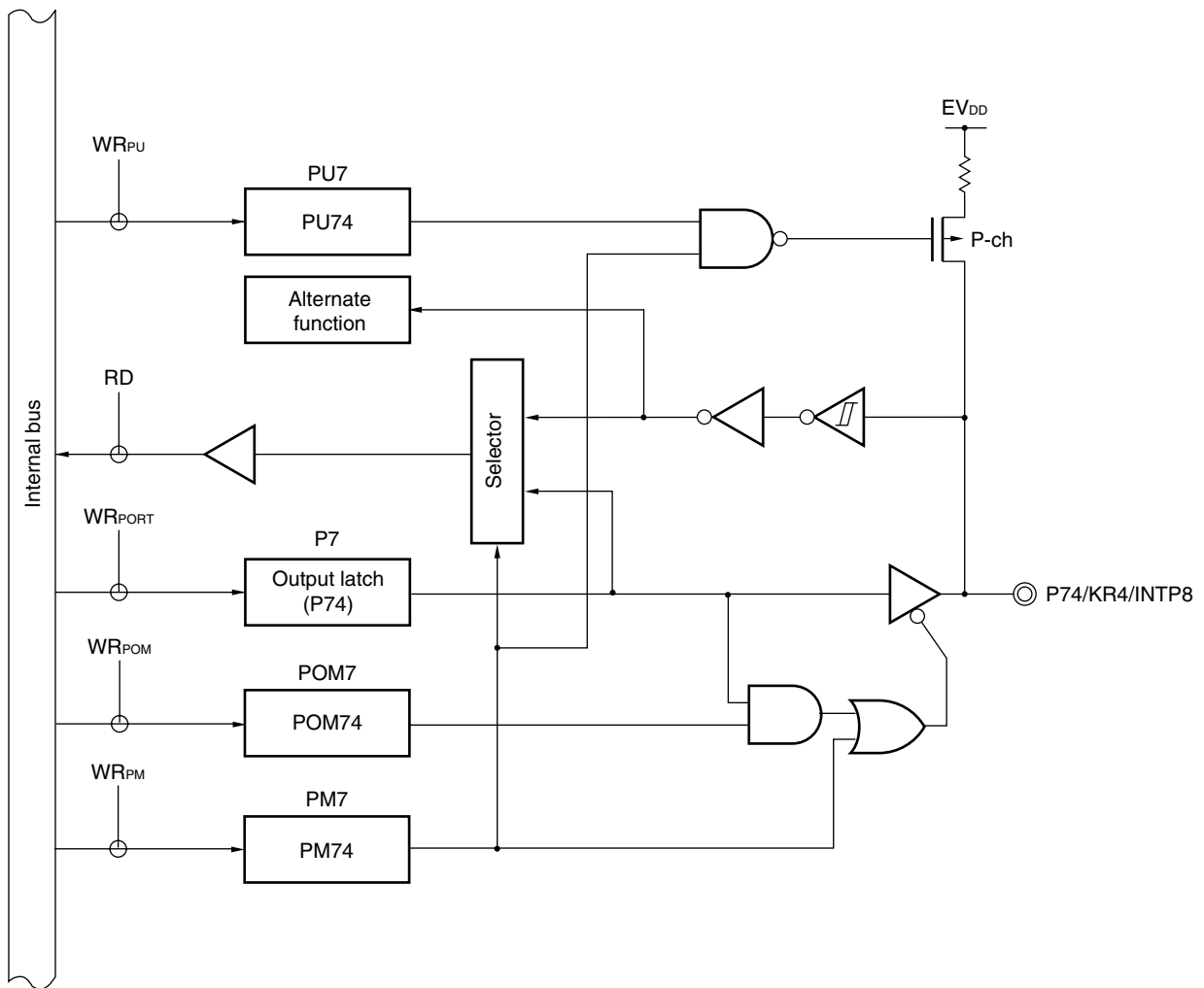
- P7: Port register 7
- PU7: Pull-up resistor option register 7
- PM7: Port mode register 7
- RD: Read signal
- WR<sub>xx</sub>: Write signal

Figure 4-37. Block Diagram of P73, P75 to P77



- P7: Port register 7
- PU7: Pull-up resistor option register 7
- PM7: Port mode register 7
- RD: Read signal
- WR<sub>xx</sub>: Write signal

Figure 4-38. Block Diagram of P74



- P7: Port register 7
- PU7: Pull-up resistor option register 7
- PM7: Port mode register 7
- POM7: Port output mode register 7
- RD: Read signal
- WR<sub>xx</sub>: Write signal

#### 4.2.9 Port 8

Port 8 is an I/O port with an output latch. Port 8 can be set to the input mode or output mode in 1-bit units using port mode register 8 (PM8). When the P80 to P87 pins are used as an input port, use of an on-chip pull-up resistor can be specified in 1-bit units by pull-up resistor option register 8 (PU8).

Input to the P80 and P81 pins can be specified through a normal input buffer or a TTL input buffer in 1-bit units using port input mode register 8 (PIM8).

Output from the P80 to P82 pin can be specified as N-ch open-drain output ( $V_{DD}$  tolerance) in 1-bit units using port output mode register 8 (POM8).

Reset signal generation sets port 8 to input mode.

<R>

**Table 4-12. Settings of Registers When Using Port 8**

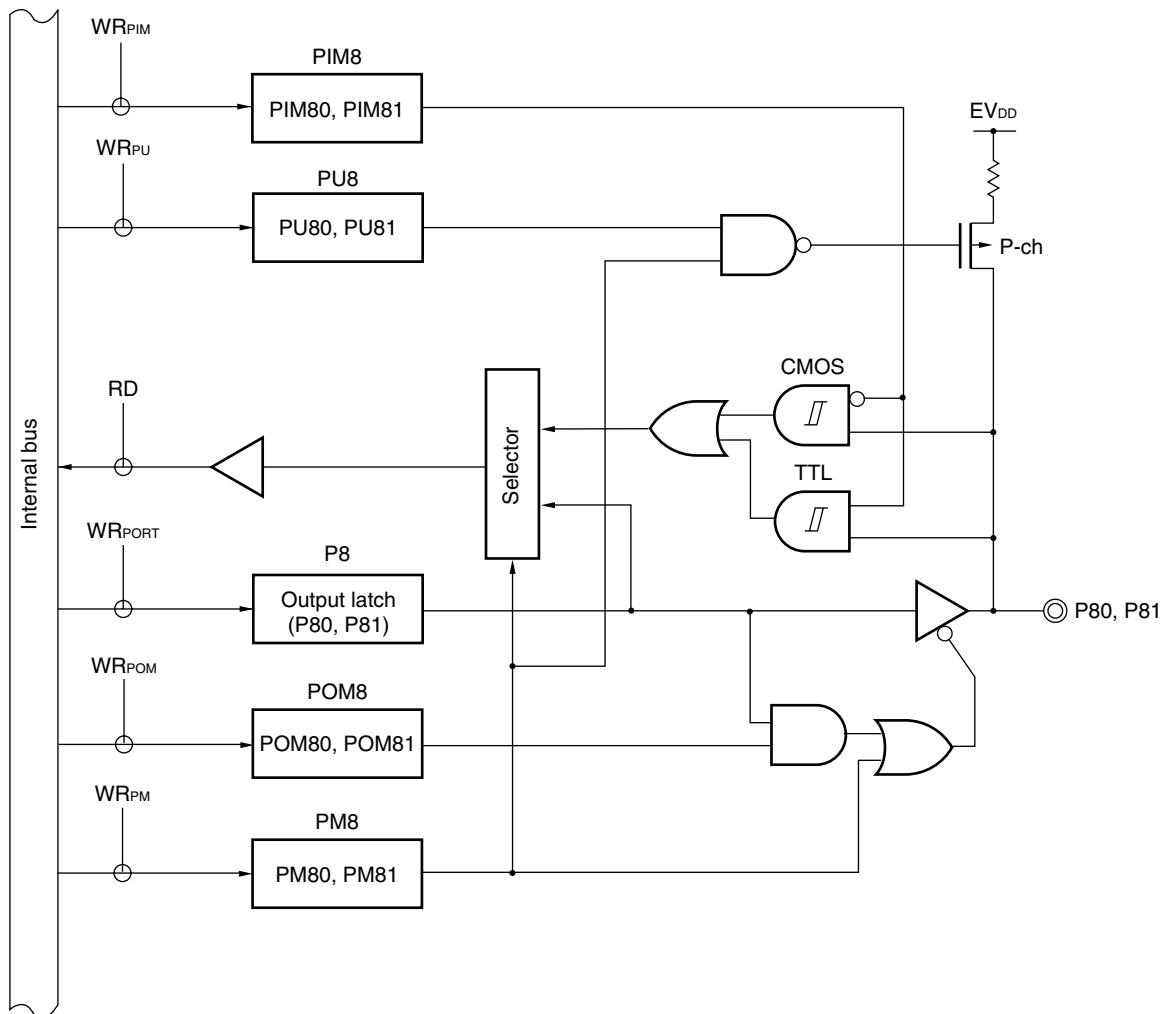
Pin Name		PM8×	PIM8×	POM8×	Alternate Function Setting <sup>Note 2</sup>	Remark
Name	I/O					
P80	Input	1	0	×	×	CMOS input
		1	1	×	×	TTL input
	Output	0	×	0	(SCK10/SCL10 output = 1 <sup>Note 1</sup> )	CMOS output
		0	×	1		N-ch O.D. output
P81	Input	1	0	×	×	CMOS input
		1	1	×	×	TTL input
	Output	0	×	0	(SDA10 output = 1 <sup>Note 1</sup> )	CMOS output
		0	×	1		N-ch O.D. output
P82	Input	1	–	×	×	
	Output	0		0	(TxD1/SO10 output = 1 <sup>Note 1</sup> )	CMOS output
		0		1		N-ch O.D. output
P83 to P87	Input	1	–	–	×	
	Output	0			×	

- Notes 1.** To use P80 to P82 as a general-purpose port when PIOR5 = 1, set serial channel enable status register 1 (SE1), serial output register 1 (SO1) and serial output enable register 1 (SOE1) to the default status.
- 2.** The descriptions in parentheses indicate the case where PIORx = 1.

**Remark** ×: don't care  
 PM8×: Port mode register 8  
 PIM8×: Port input mode register 8  
 POM8×: Port output mode register 8  
 PIOR×: Peripheral I/O redirection register

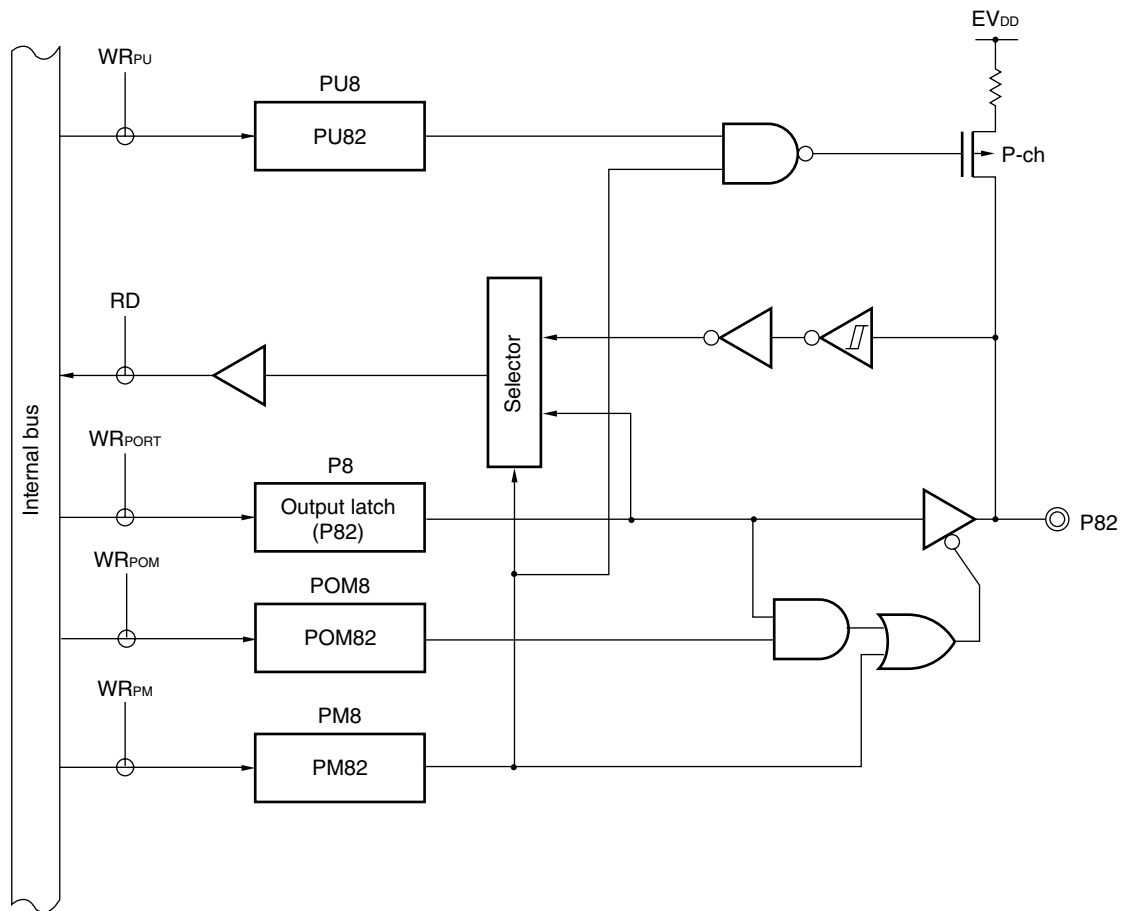
<R> For example, figures 4-39 to 4-41 show block diagrams of port 8 for 128-pin products when PIOR = 00H.

Figure 4-39. Block Diagram of P80, P81



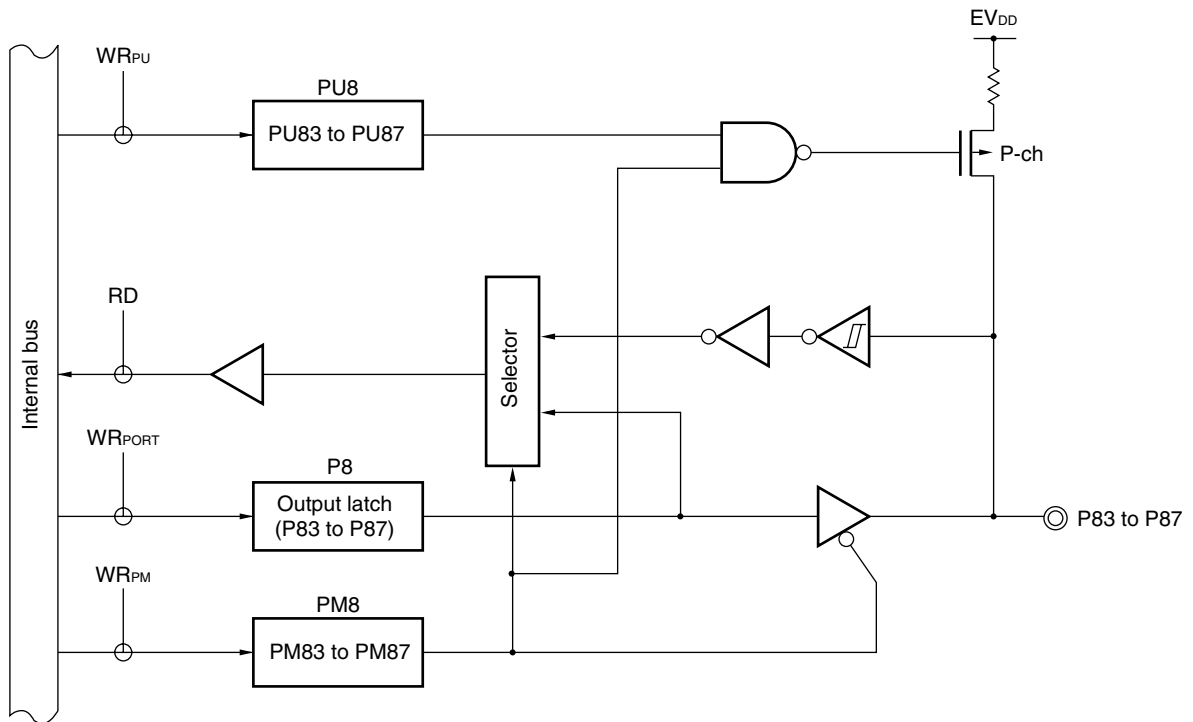
- P8: Port register 8
- PU8: Pull-up resistor option register 8
- PM8: Port mode register 8
- PIM8: Port input mode register 8
- POM8: Port output mode register 8
- RD: Read signal
- WR<sub>xx</sub>: Write signal

Figure 4-40. Block Diagram of P82



- P8: Port register 8
- PU8: Pull-up resistor option register 8
- PM8: Port mode register 8
- PIM8: Port input mode register 8
- POM8: Port output mode register 8
- RD: Read signal
- WR<sub>xx</sub>: Write signal

Figure 4-41. Block Diagram of P83 to P87



- P8: Port register 8
- PU8: Pull-up resistor option register 8
- PM8: Port mode register 8
- RD: Read signal
- $WR_{xx}$ : Write signal



#### 4.2.10 Port 9

Port 9 is an I/O port with an output latch. Port 9 can be set to the input mode or output mode in 1-bit units using port mode register 9 (PM9). When used as an input port, use of an on-chip pull-up resistor can be specified in 1-bit units by pull-up resistor option register 9 (PU9).

Output from the P96 pin can be specified as N-ch open-drain output ( $V_{DD}$  tolerance) in 1-bit units using port output mode register 9 (POM9).

This port can also be used for serial interface data I/O, clock I/O.

Reset signal generation sets port 9 to input mode.

<R>

**Table 4-13. Settings of Registers When Using Port 9**

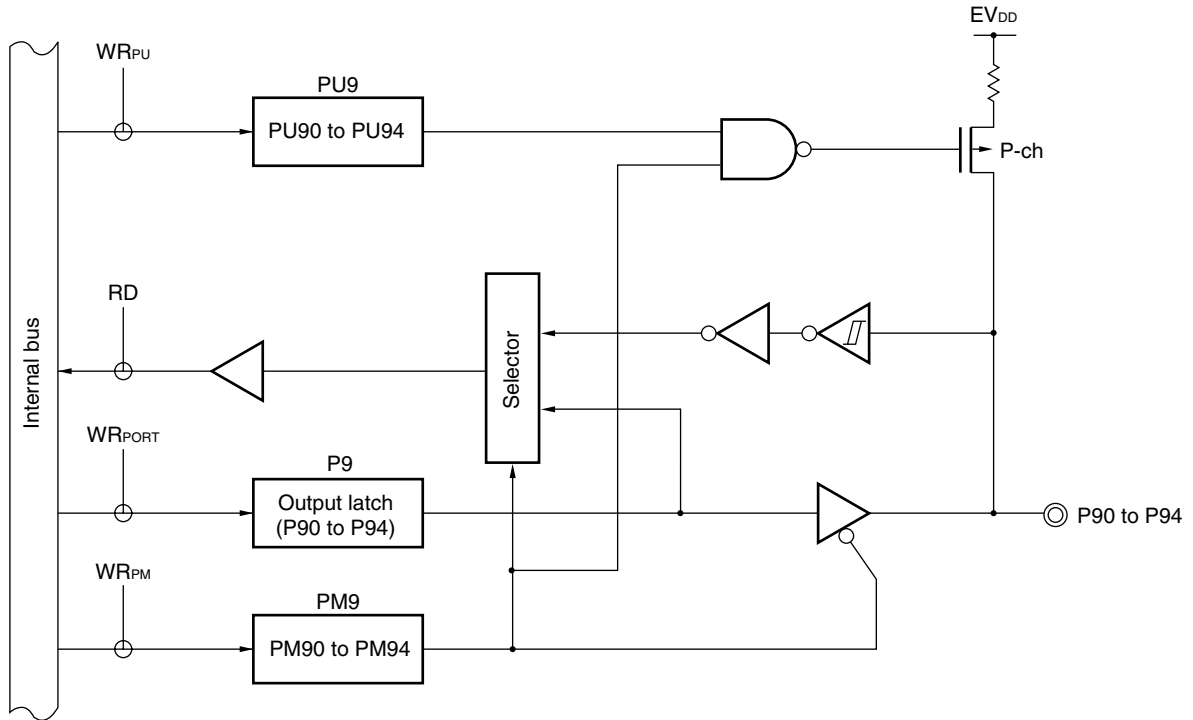
Pin Name		PM9×	POM9×	Alternate Function Setting	Remark
Name	I/O				
P90 to P94	Input	1	–	–	
	Output	0		–	
P95	Input	1	–	×	
	Output	0		SCK11/SCL11 output = 1 <sup>Note</sup>	
P96	Input	1	×	×	
	Output	0	0	SDA11 output = 1 <sup>Note</sup>	CMOS output
		0	1		N-ch O.D. output
P97	Input	1	–	×	
	Output	0		SO11 output = 1 <sup>Note</sup>	

**Note** P95/SCK11/SCL11, P96/SI11/SDA11 or P97/SO11 as a general-purpose port, set serial channel enable status register 0 (SE0), serial output register 0 (SO0) and serial output enable register 0 (SOE0) to the default status.

**Remark** ×: don't care  
 PM9×: Port mode register 9  
 POM9×: Port output mode register 9

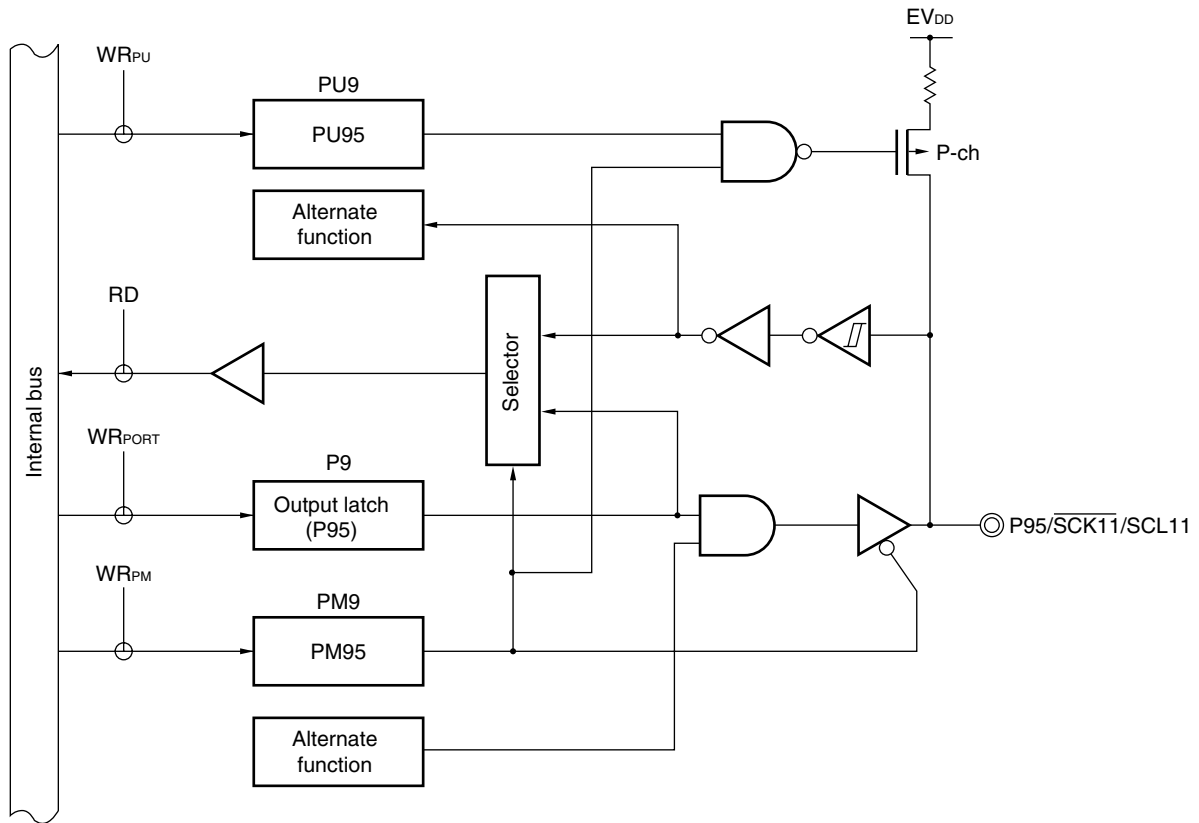
For example, figures 4-42 to 4-45 show block diagrams of port 9.

Figure 4-42. Block Diagram of P90 to P94



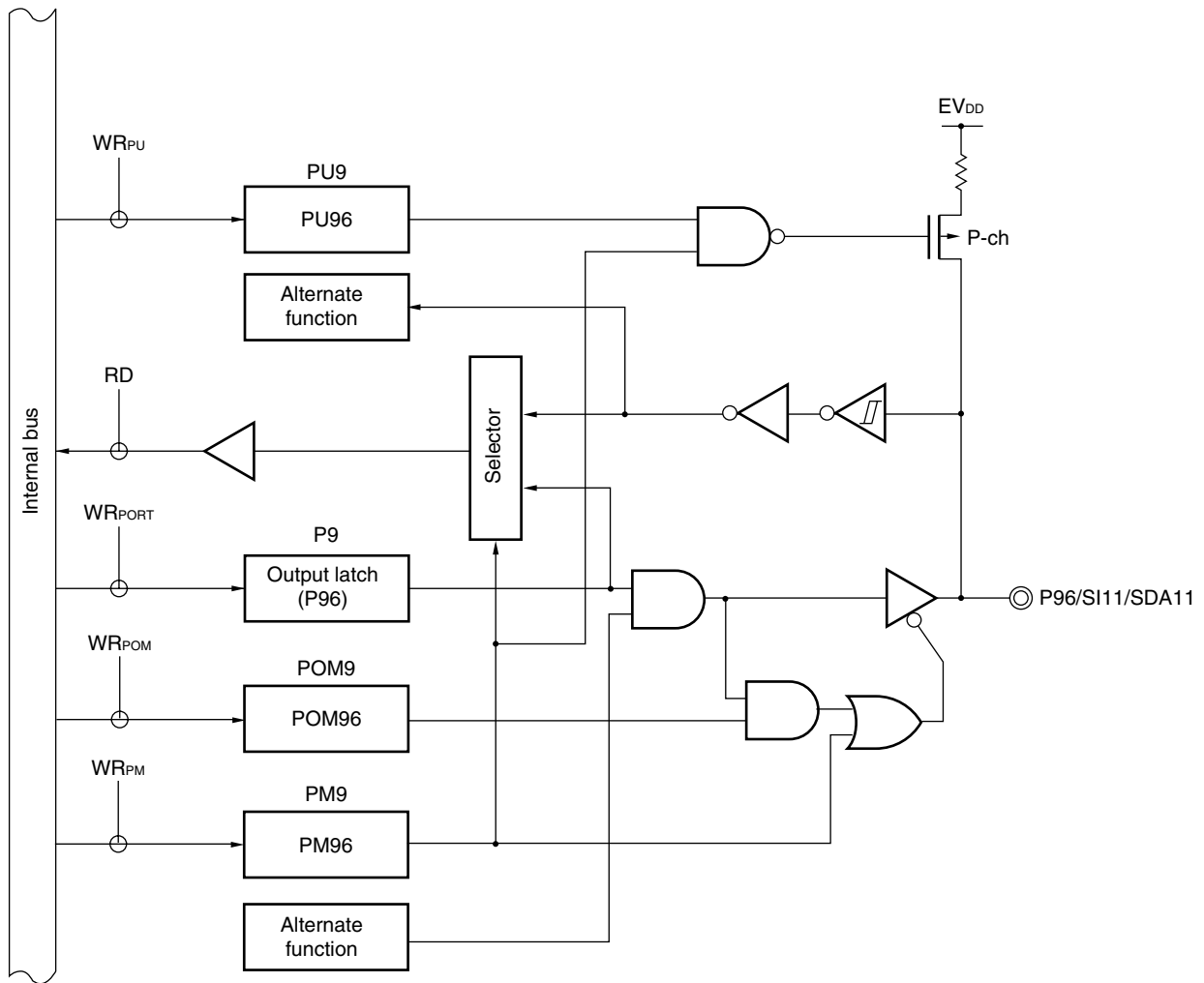
- P9: Port register 9
- PU9: Pull-up resistor option register 9
- PM9: Port mode register 9
- RD: Read signal
- WR<sub>xx</sub>: Write signal

Figure 4-43. Block Diagram of P95



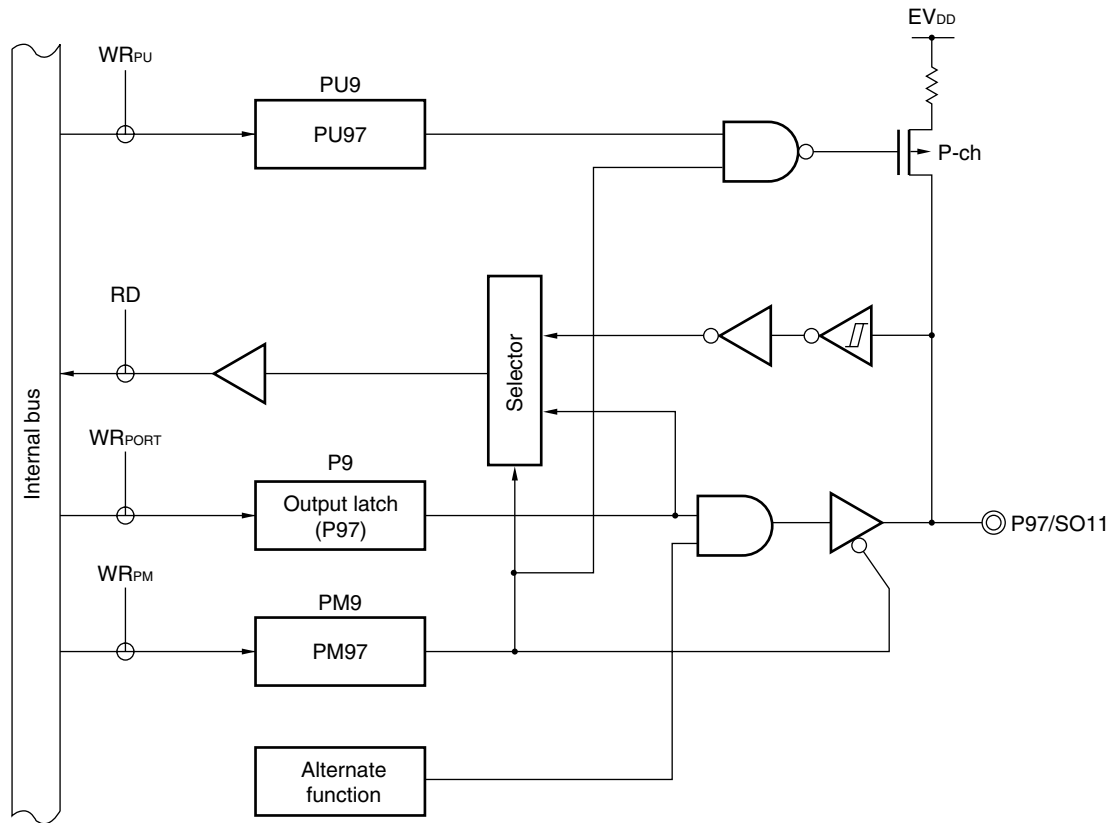
- P9: Port register 9
- PU9: Pull-up resistor option register 9
- PM9: Port mode register 9
- RD: Read signal
- WR<sub>xx</sub>: Write signal

Figure 4-44. Block Diagram of P96



- P9: Port register 9
- PU9: Pull-up resistor option register 9
- PM9: Port mode register 9
- POM9: Port output mode register 9
- RD: Read signal
- WR<sub>xx</sub>: Write signal

Figure 4-45. Block Diagram of P97



- P9: Port register 9
- PU9: Pull-up resistor option register 9
- PM9: Port mode register 9
- RD: Read signal
- WR<sub>xx</sub>: Write signal

### 4.2.11 Port 10

Port 10 is an I/O port with an output latch. Port 10 can be set to the input mode or output mode in 1-bit units using port mode register 10 (PM10). When the P100 to P106 pins are used as an input port, use of an on-chip pull-up resistor can be specified in 1-bit units by pull-up resistor option register 10 (PU10).

<R> Input to the P100 pin can be specified as analog input or digital input in 1-bit units, using port mode control register 10 (PMC10).

This port can also be used for timer I/O and A/D converter analog input.

<R> Reset signal generation sets P100 to analog input, P101 to P106 to input mode.

<R> **Table 4-14. Settings of Registers When Using Port 10**

Pin Name		PM10×	PMC10×	Alternate Function Setting	Remark
Name	I/O				
P100	Input	1	0	×	
	Output	0	0	×	
P101	Input	1	–	–	
	Output	0			
P102	Input	1	–	×	
	Output	0		TO06 output = 0 <sup>Note 1</sup>	
P103 to P106	Input	1	–	×	
	Output	0		TO14 to TO17 outputs = 0 <sup>Note 2</sup>	

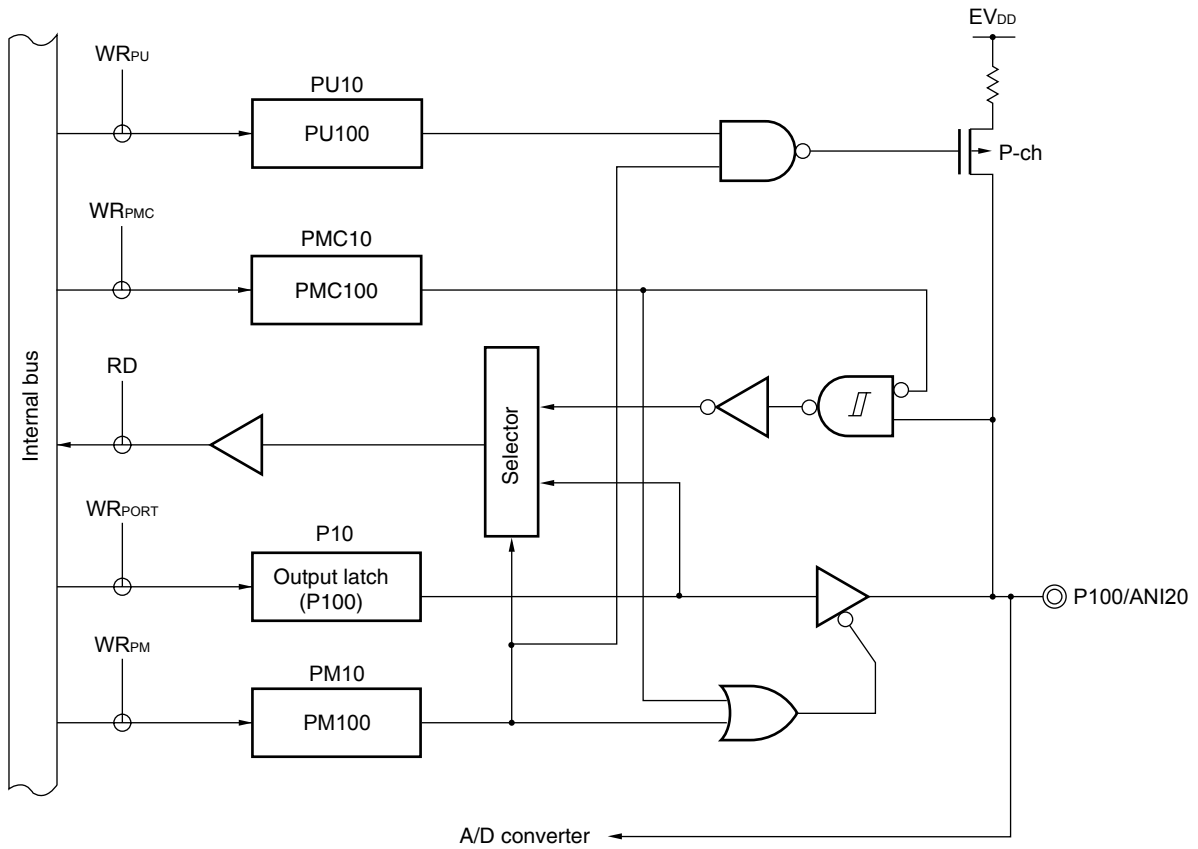
- Notes**
1. To use P102/TI06/TO06 as a general-purpose port, set bit 6 (TO06) of timer output register 0 (TO0) and bit 6 (TOE06) of timer output enable register 0 (TOE0) to “0”, which is the same as their default status setting.
  2. To use P103/TI14/TO14 to P106/TI17/TO17 as a general-purpose port, set bits 4 to 7 (TO14 to TO17) of timer output register 1 (TO1) and bits 4 to 7 (TOE14 to TOE17) of timer output enable register 1 (TOE1) to “0”, which is the same as their default status setting.

**Remark**

- ×: don't care
- PM10×: Port mode register 10
- PMC10×: Port mode control register 10

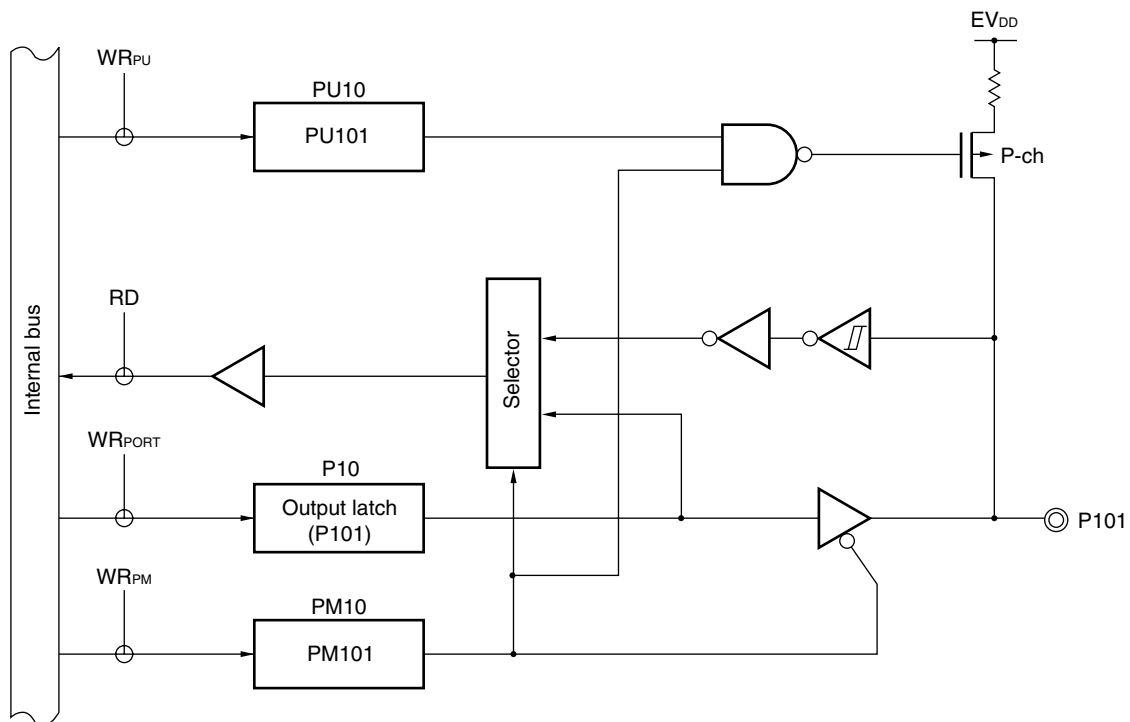
For example, figures 4-46 to 4-48 show block diagrams of port 10.

Figure 4-46. Block Diagram of P100



- P10: Port register 10
- PU10: Pull-up resistor option register 10
- PM10: Port mode register 10
- PMC10: Port mode control register 10
- RD: Read signal
- WR<sub>xx</sub>: Write signal

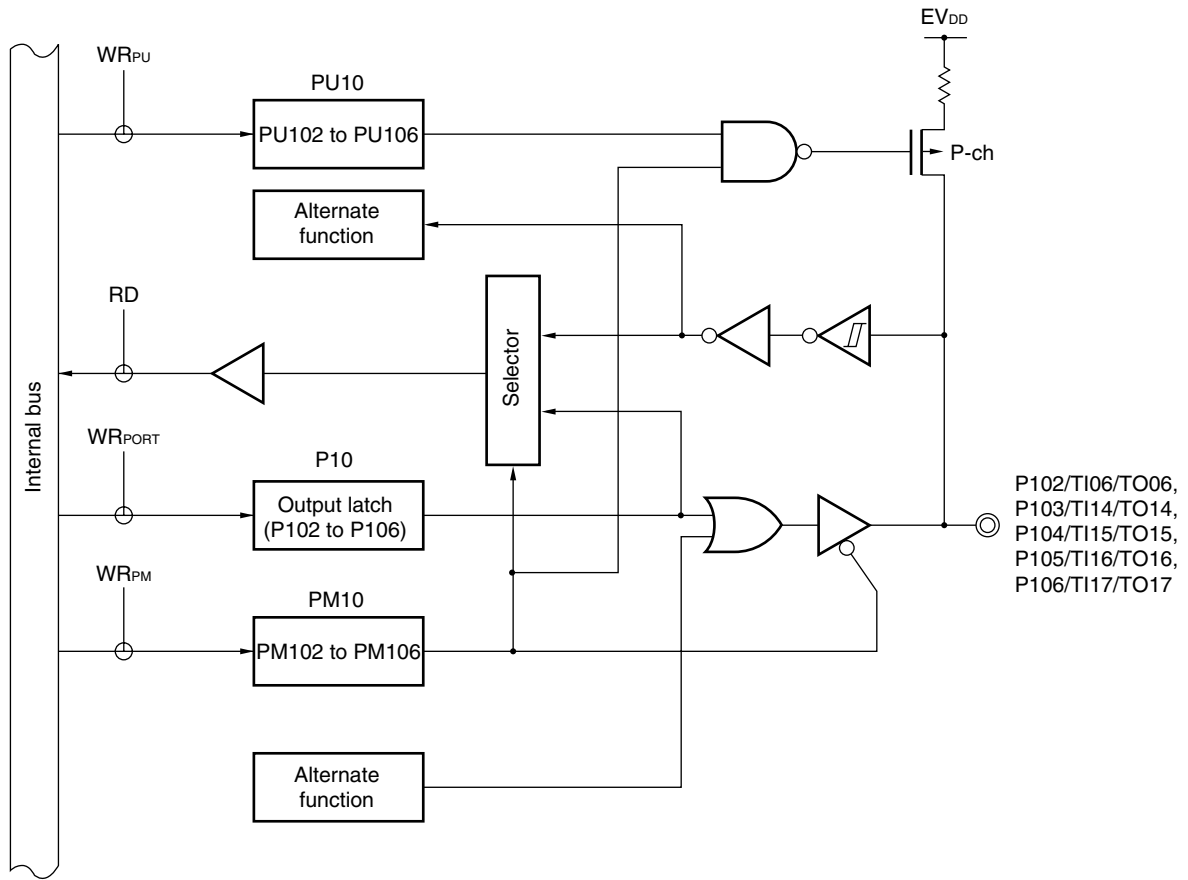
Figure 4-47. Block Diagram of P101



- P10: Port register 10
- PU10: Pull-up resistor option register 10
- PM10: Port mode register 10
- RD: Read signal
- WR<sub>xx</sub>: Write signal



Figure 4-48. Block Diagram of P102 to P106



- P10: Port register 10
- PU10: Pull-up resistor option register 10
- PM10: Port mode register 10
- RD: Read signal
- WR<sub>xx</sub>: Write signal

#### 4.2.12 Port 11

Port 11 is an I/O port with an output latch. Port 11 can be set to the input mode or output mode in 1-bit units using port mode register 11 (PM11). When the P110 to P117 pins are used as an input port, use of an on-chip pull-up resistor can be specified in 1-bit units by pull-up resistor option register 11 (PU11).

<R> Input to the P115 to P117 pins can be specified as analog input or digital input in 1-bit units, using port mode control register 11 (PMC11).

This port can also be used for A/D converter analog input.

<R> Reset signal generation sets P110 to P114 to input mode, and sets P115 to P117 to analog input.

<R> **Table 4-15. Settings of Registers When Using Port 11**

Pin Name		PM11×	PMC11×	Alternate Function Setting <sup>Note 3</sup>	Remark
Name	I/O				
P110, P111	Input	1	–	×	
	Output	0			
P112 to P114	Input	1	–	–	
	Output	0			
P115 to P117	Input	1	0	×	
	Output	0	0	×	

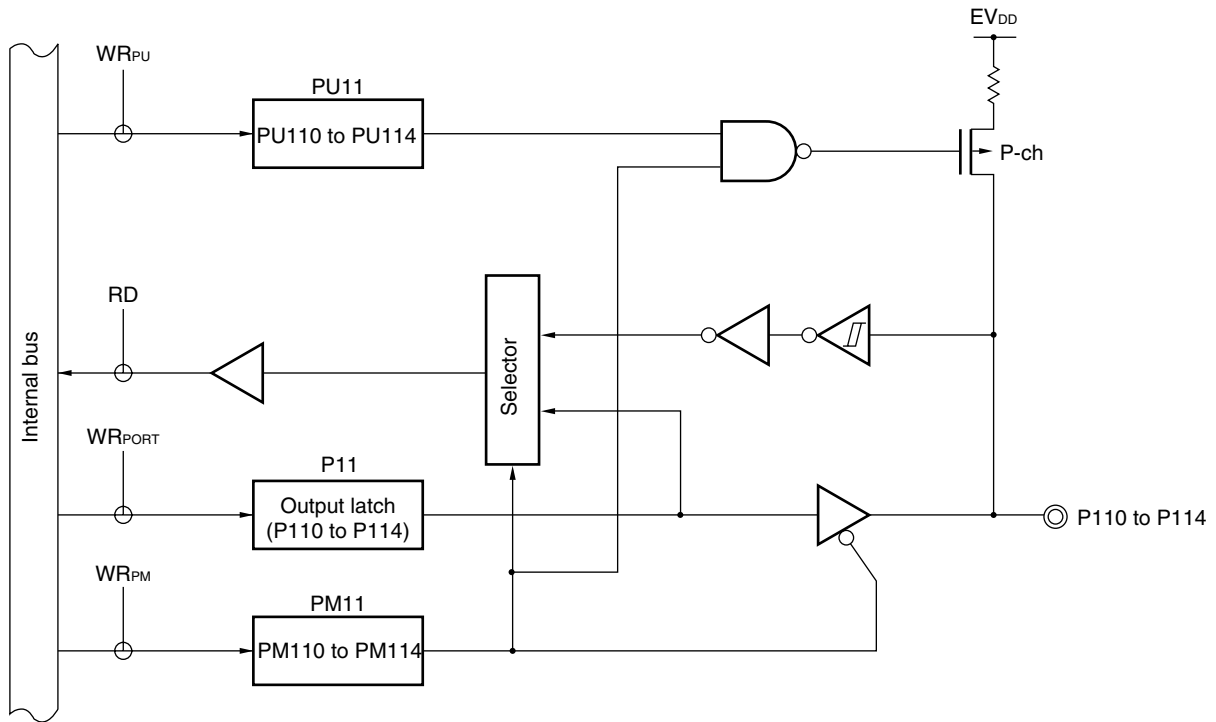
**Remark** ×: don't care

PM11×: Port mode register 11

PMC11×: Port mode control register 11

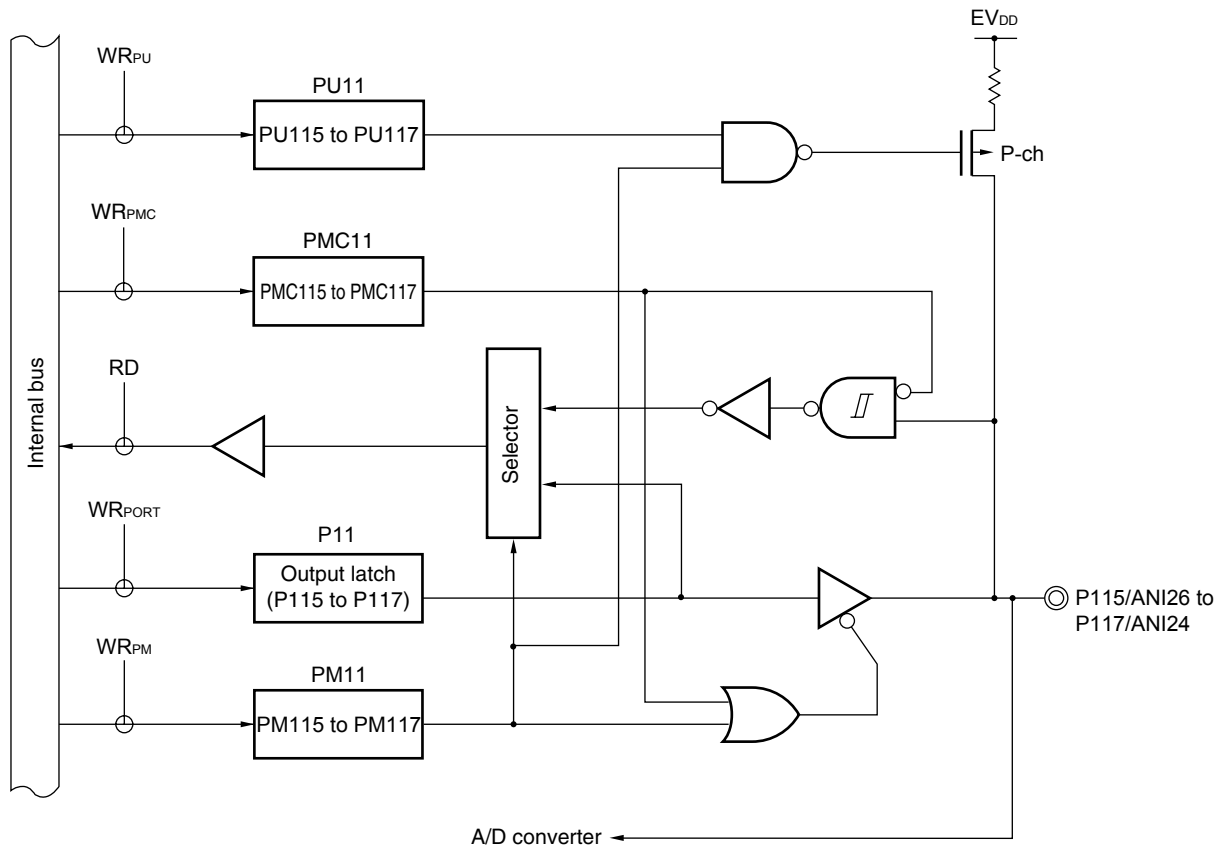
<R> For example, 4-49 and 4-50 show block diagrams of port 11 for 128-pin products when PIOR = 00H.

Figure 4-49. Block Diagram of P110 to P114



- P11: Port register 11
- PU11: Pull-up resistor option register 11
- PM11: Port mode register 11
- RD: Read signal
- WR<sub>xx</sub>: Write signal

Figure 4-50. Block Diagram of P115 to P117



- P11: Port register 11
- PU11: Pull-up resistor option register 11
- PM11: Port mode register 11
- PMC11: Port mode control register 11
- RD: Read signal
- WR<sub>xx</sub>: Write signal

### 4.2.13 Port 12

P120 and P125 to 127 are an I/O port with an output latch. Port 12 can be set to the input mode or output mode in 1-bit units using port mode register 12 (PM12). When used as an input port, use of an on-chip pull-up resistor can be specified by pull-up resistor option register 12 (PU12).

P121 to P124 are 4-bit input only ports.

<R> Input to the P120 pin can be specified as analog input or digital input in 1-bit units, using port mode control register 12 (PMC12).

This port can also be used for A/D converter analog input, connecting resonator for main system clock, connecting resonator for subsystem clock, external clock input for main system clock, and external clock input for subsystem clock.

<R> Reset signal generation sets P120 to analog input, and sets P121 to P127 to input mode.

<R> **Table 4-16. Settings of Registers When Using Port 12**

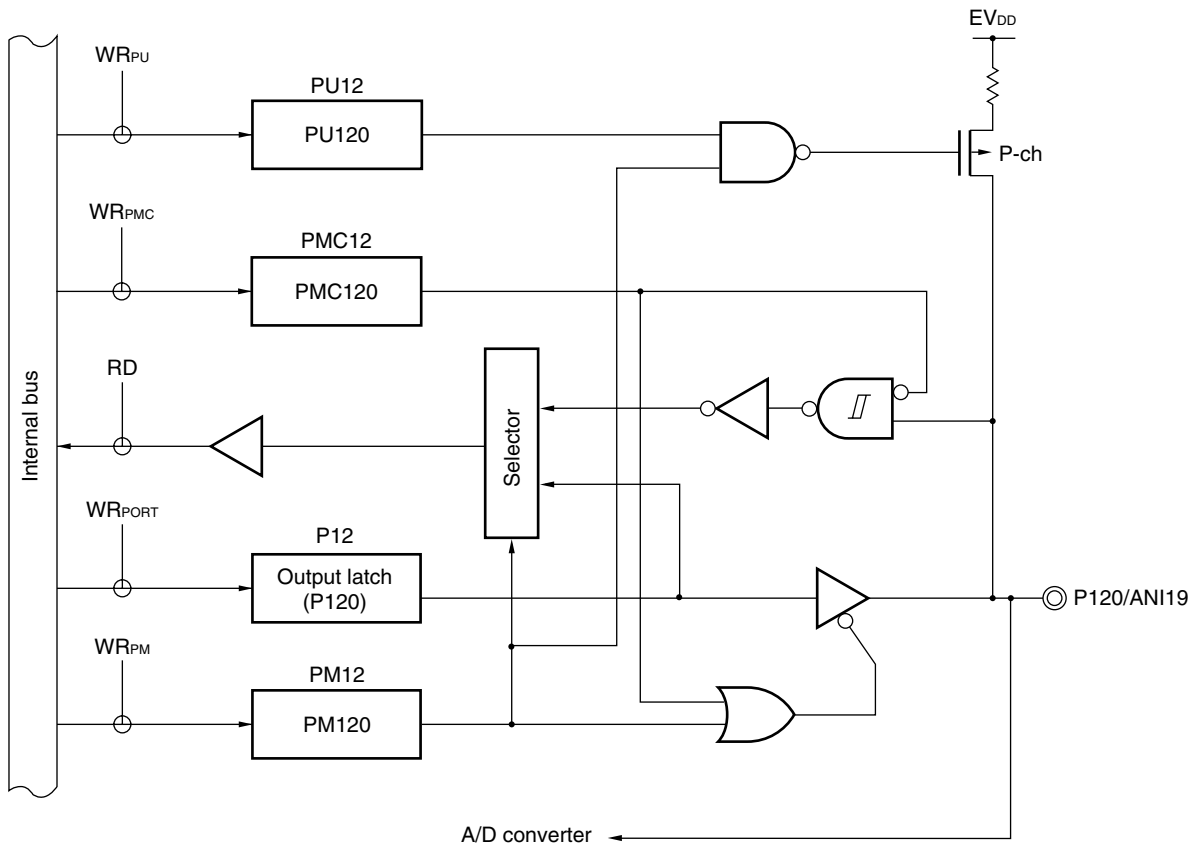
Pin Name		PM12 $\times$	PMC12 $\times$	Alternate Function Setting	Remark
Name	I/O				
P120	Input	1	0	×	
	Output	0	0	×	
P121	Input	–	–	OSCSEL bit of CMC register = 0 or EXCLK bit = 1	
P122	Input	–	–	OSCSEL bit of CMC register = 0	
P123	Input	–	–	OSCSELS bit of CMC register = 0 or EXCLKS bit = 1	
P124	Input	–	–	OSCSELS bit of CMC register = 0	
P125 to	Input	1	–	–	
P127	Output	0			

**Caution** The function setting on P121 to P124 is available only once after the reset release. The port once set for connection to an oscillator cannot be used as an input port unless the reset is performed.

**Remark** ×: don't care  
 PM12 $\times$ : Port mode register 12  
 PMC12 $\times$ : Port mode control register 12

<R> For example, figures 4-51 to 4-54 show block diagrams of port 12 for 128-pin products when PIOR = 00H.

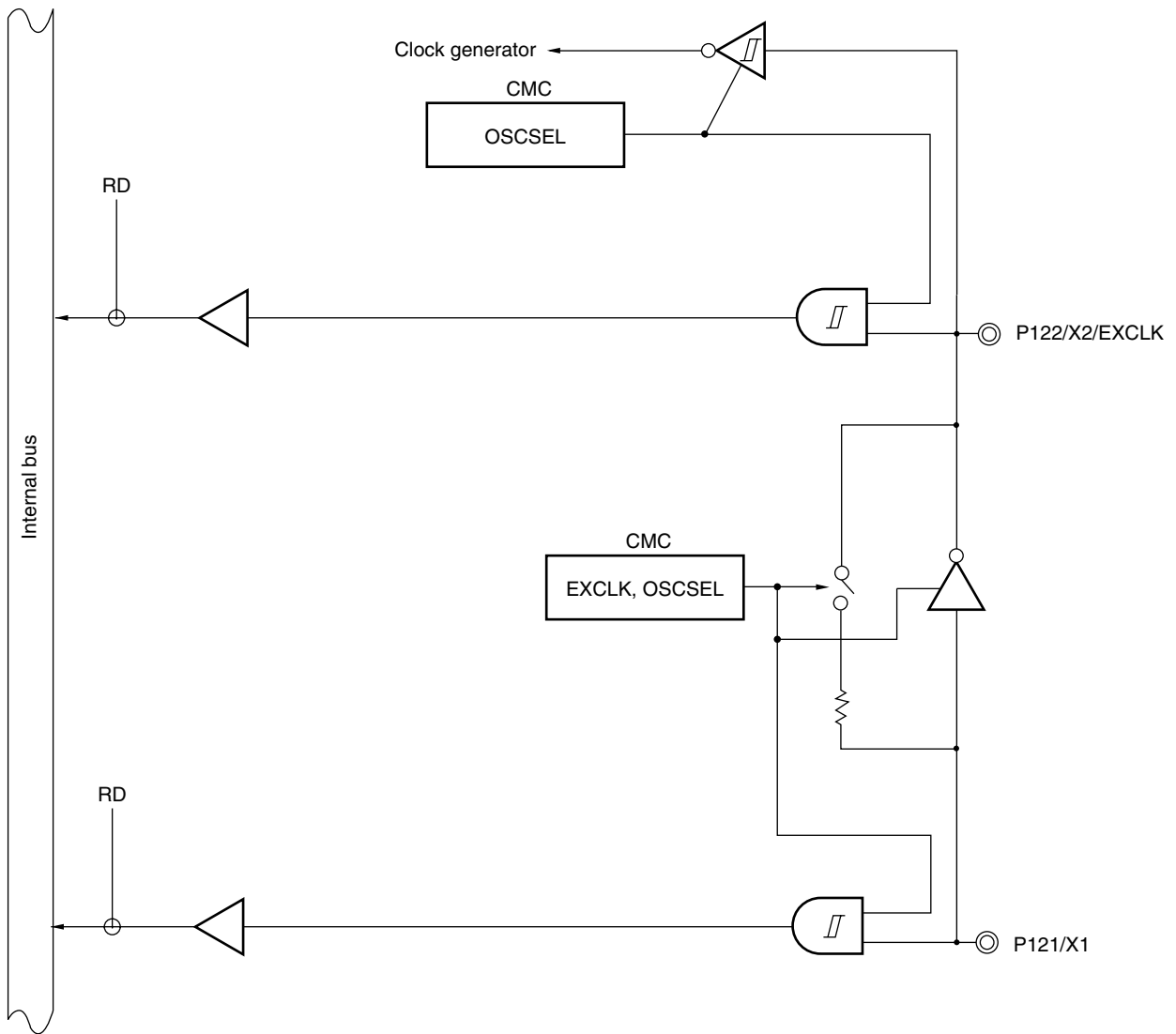
Figure 4-51. Block Diagram of P120



- P12: Port register 12
- PU12: Pull-up resistor option register 12
- PM12: Port mode register 12
- PMC12: Port mode control register 12
- RD: Read signal
- WR<sub>xx</sub>: Write signal

<R>

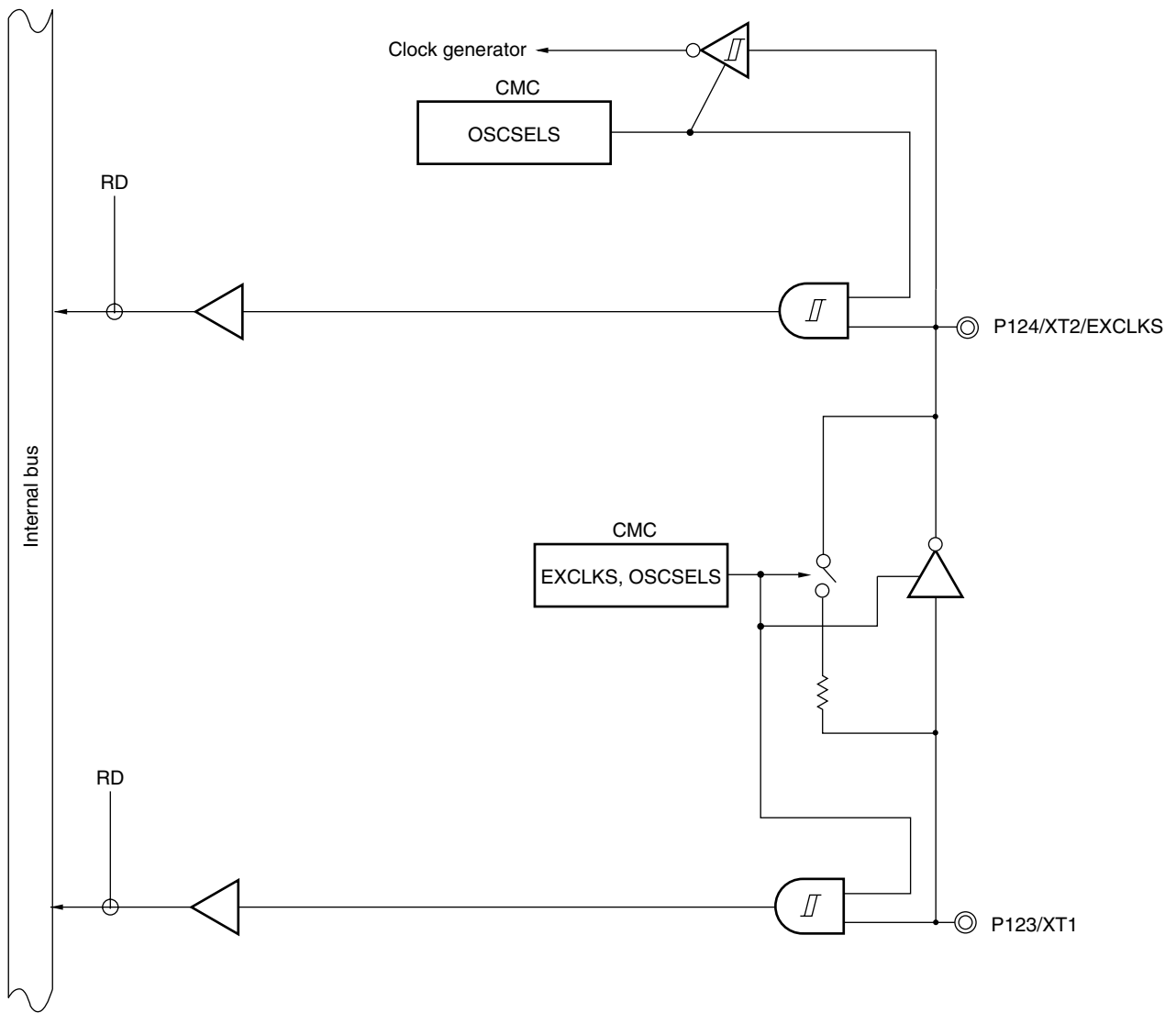
Figure 4-52. Block Diagram of P121 and P122



CMC: Clock operation mode control register  
 RD: Read signal

<R>

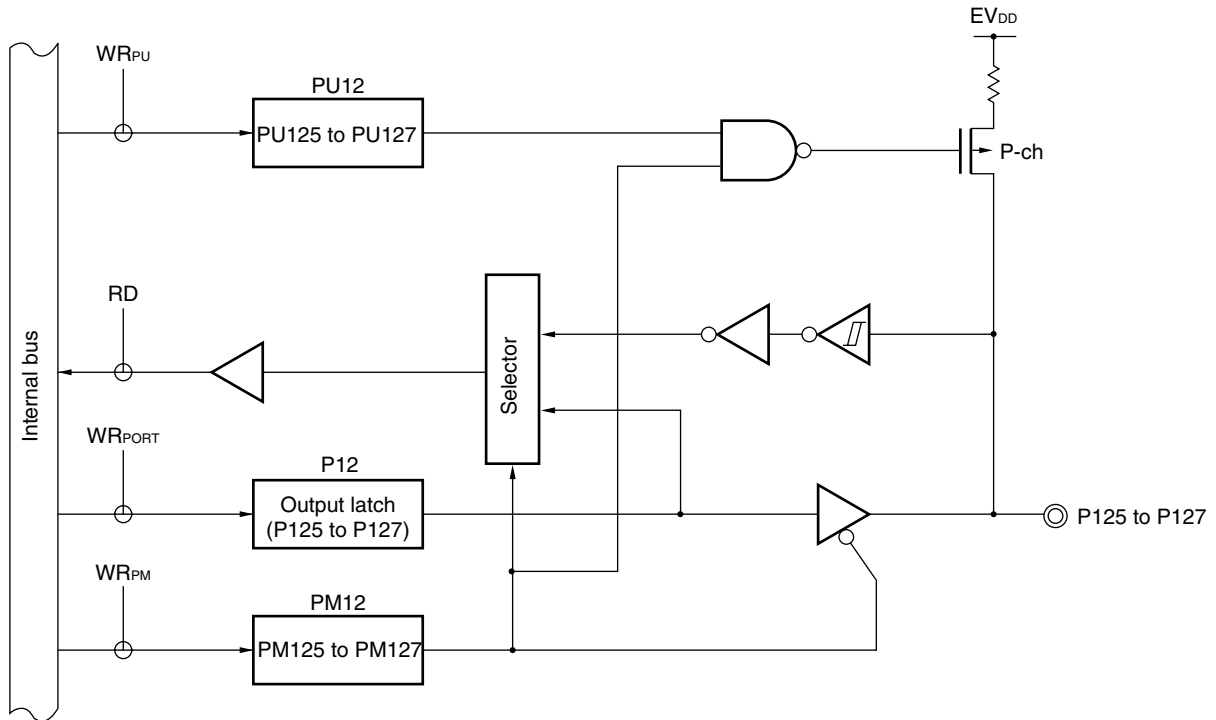
Figure 4-53. Block Diagram of P123 and P124



CMC: Clock operation mode control register  
 RD: Read signal



Figure 4-54. Block Diagram of P125 to P127



- P12: Port register 12
- PU12: Pull-up resistor option register 12
- PM12: Port mode register 12
- RD: Read signal
- WR<sub>xx</sub>: Write signal

**4.2.14 Port 13**

P130 is a 1-bit output-only port with an output latch.

P137 is a 1-bit input-only port.

<R> P130 is fixed an output port, and P137 is fixed an input ports.  
This port can also be used for external interrupt request input.

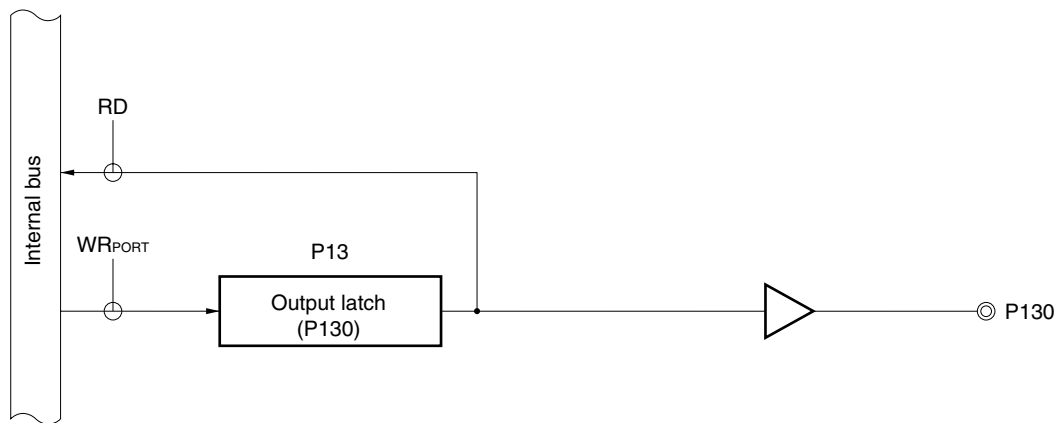
<R> **Table 4-17. Settings of Registers When Using Port 13**

Pin Name		Alternate Function Setting	Remark
Name	I/O		
P130	Output	—	
P137	Input	×	

**Remark** ×: don't care

Figures 4-55 and 4-56 show block diagrams of port 13.

**Figure 4-55. Block Diagram of P130**



P13: Port register 13  
RD: Read signal  
WR<sub>xx</sub>: Write signal

**Remark** When reset is effected, P130 outputs a low level. If P130 is set to output a high level before reset is effected, the output signal of P130 can be dummy-output as the CPU reset signal.

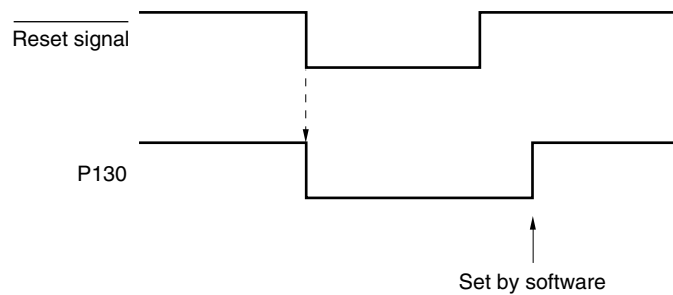
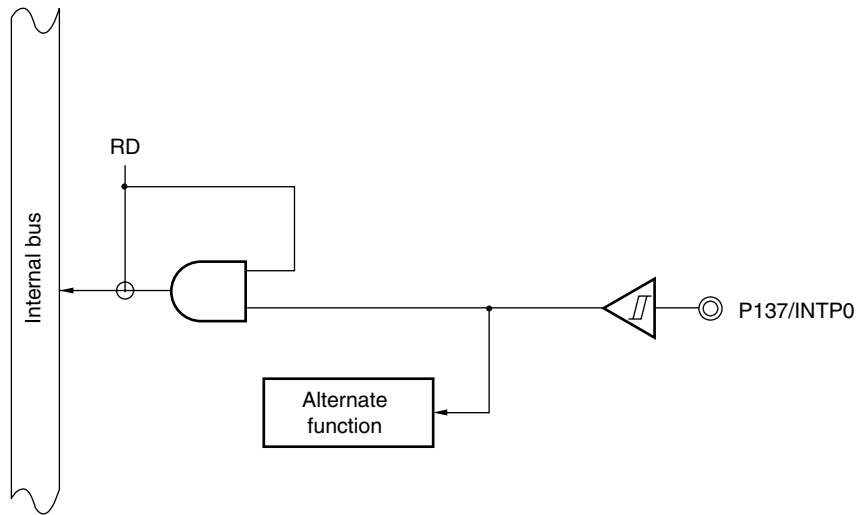


Figure 4-56. Block Diagram of P137



RD: Read signal

#### 4.2.15 Port 14

Port 14 is an I/O port with an output latch. Port 14 can be set to the input mode or output mode in 1-bit units using port mode register 14 (PM14). When the P140 to P147 pins are used as an input port, use of an on-chip pull-up resistor can be specified in 1-bit units by pull-up resistor option register 14 (PU14).

Input to the P142 and P143 pins can be specified through a normal input buffer or a TTL input buffer in 1-bit units using port input mode register 14 (PIM14).

Output from the P142 to P144 pins can be specified as N-ch open-drain output ( $V_{DD}$  tolerance) in 1-bit units using port output mode register 14 (POM14).

<R> Input to the P147 pin can be specified as analog input or digital input in 1-bit units, using port mode control register 14 (PMC14).

This port can also be used for clock/buzzer output, external interrupt request input, and A/D converter analog input.

<R> Reset signal generation sets P140 to P146 to input mode, and sets P147 to analog input.

<R> **Table 4-18. Settings of Registers When Using Port 14**

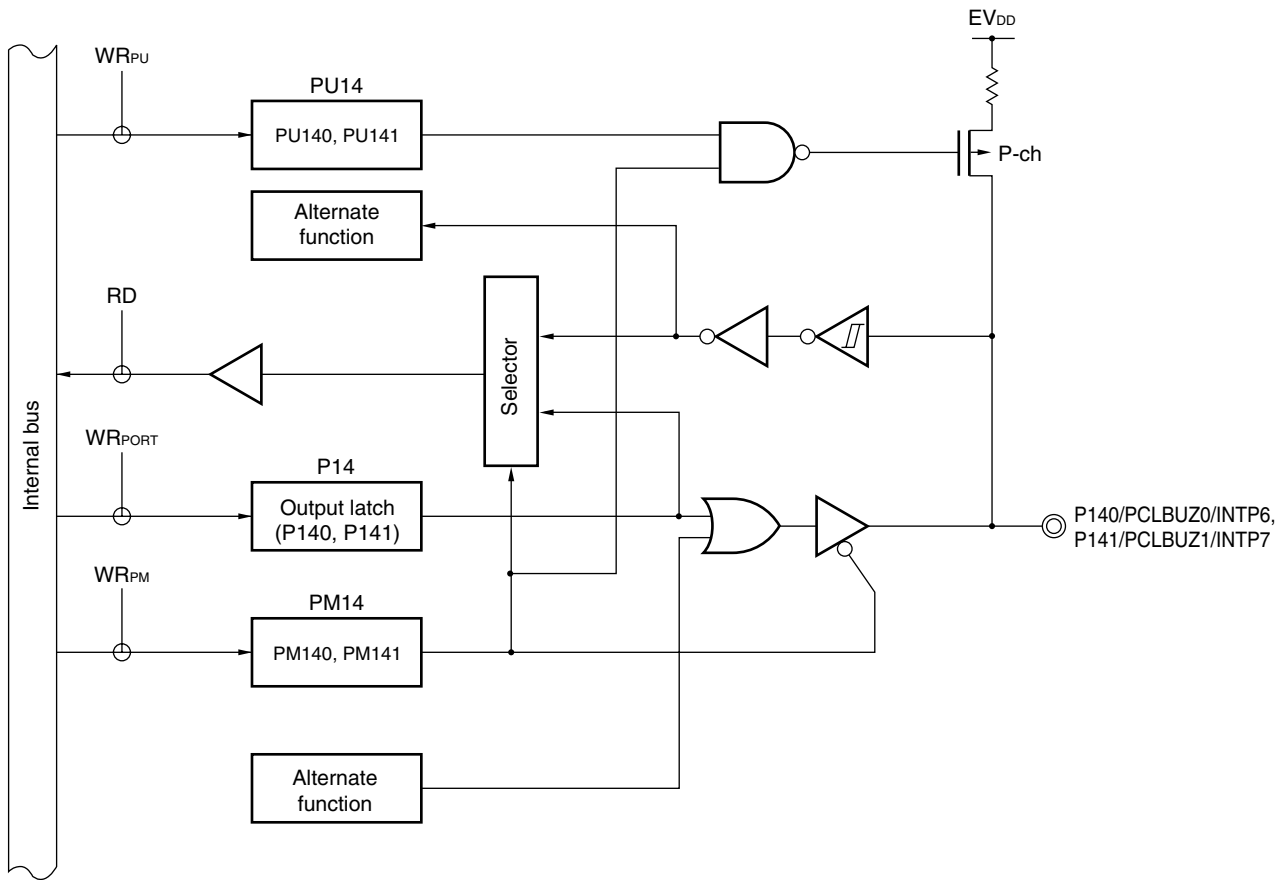
Pin Name		PM14×	PIM14×	POM14×	PMC14×	Alternate Function Setting	Remark
Name	I/O						
P140, P141	Input	1	–	–	–	×	
	Output	0				PCLBUZ0 output, PCLBUZ1 output = 0 <sup>Note 1</sup>	
P142, P143	Input	1	0	×	–	×	CMOS input
		1	1	×		×	TTL input
	Output	0	×	0		SCK30/SCL30 output = 1, SDA30 output = 1 <sup>Note 2</sup>	CMOS output
		0	×	1			N-ch O.D. output
P144	Input	1	–	×	–	×	
	Output	0		0		SO30/TxD3 output = 1 <sup>Note 2</sup>	CMOS output
		0		1			N-ch O.D. output
P145	Input	1	–	–	–	×	
	Output	0				TO07 output = 0 <sup>Note 3</sup>	
P146	Input	1	–	–	–	×	
	Output	0				×	
P147	Input	1	–	–	0	×	
	Output	0			0	×	

- Notes 1.** To use P140/PCLBUZ0/INTP6 or P141/PCLBUZ1/INTP7 as a general-purpose port, set bit 7 of clock output select registers 0 and 1 (CKS0, CKS1) to “0”, which is the same as their default status settings.
- 2.** To use P142/SCK30/SCL30, P143/SI30/RxD3/SDA30, or P144/SO30/TxD3 as a general-purpose port, set serial channel enable status register 1 (SE1), serial output register 1 (SO1) and serial output enable register 1 (SOE1) to the default status.
- 3.** To use P145/TI07/TO07 as a general-purpose port, set bit 7 (TO07) of timer output register 0 (TO0) and bit 7 (TOE07) of timer output enable register 0 (TOE0) to “0”, which is the same as their default status setting.

**Remark** ×: don't care  
 PM14×: Port mode register 14  
 PIM14×: Port input mode register 14  
 POM14×: Port output mode register 14  
 PMC14×: Port mode control register 14

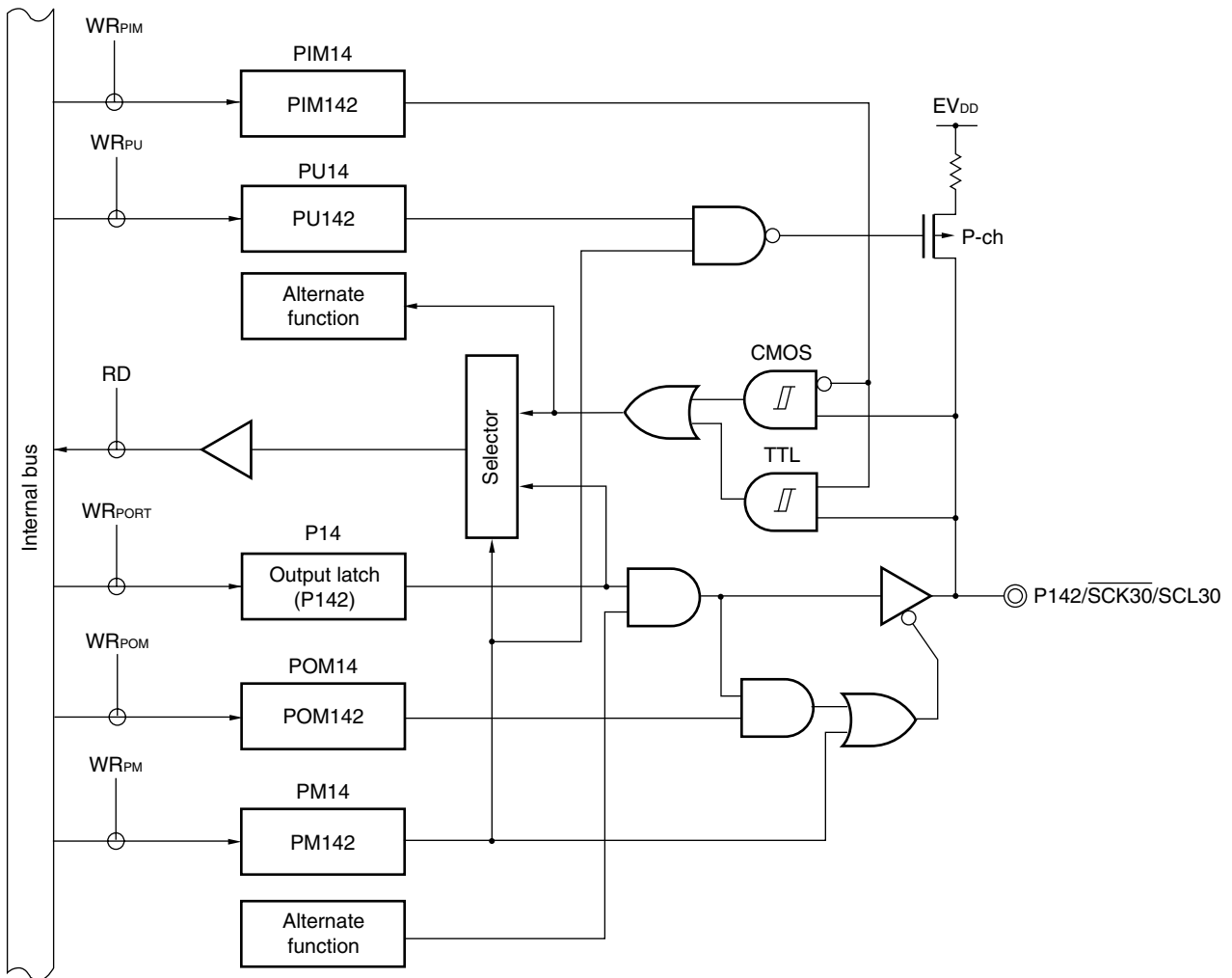
<R> For example, figures 4-57 to 4-63 show block diagrams of port 14 for 128-pin products when PIOR = 00H.

**Figure 4-57. Block Diagram of P140 and P141**



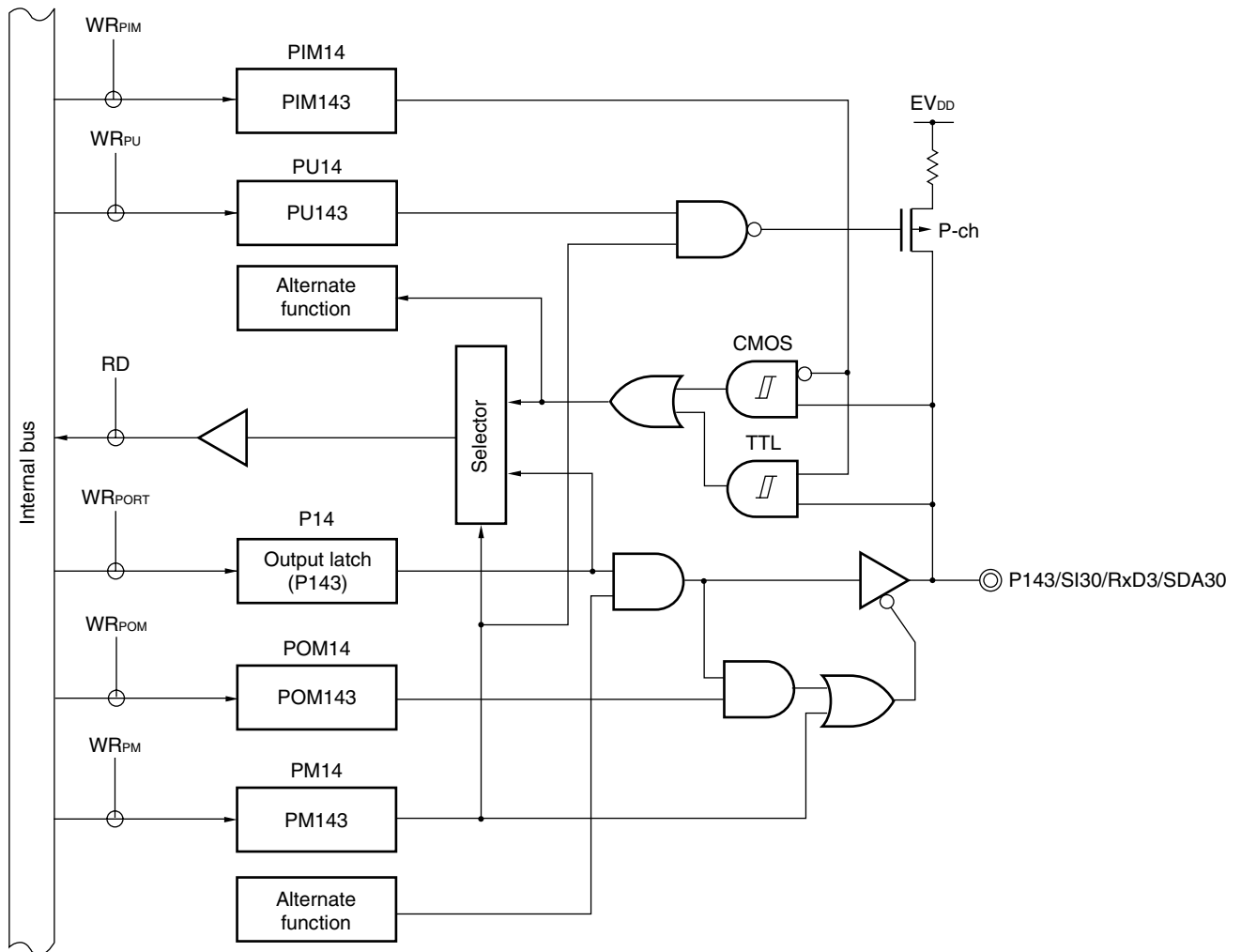
- P14: Port register 14
- PU14: Pull-up resistor option register 14
- PM14: Port mode register 14
- RD: Read signal
- WR<sub>xx</sub>: Write signal

Figure 4-58. Block Diagram of P142



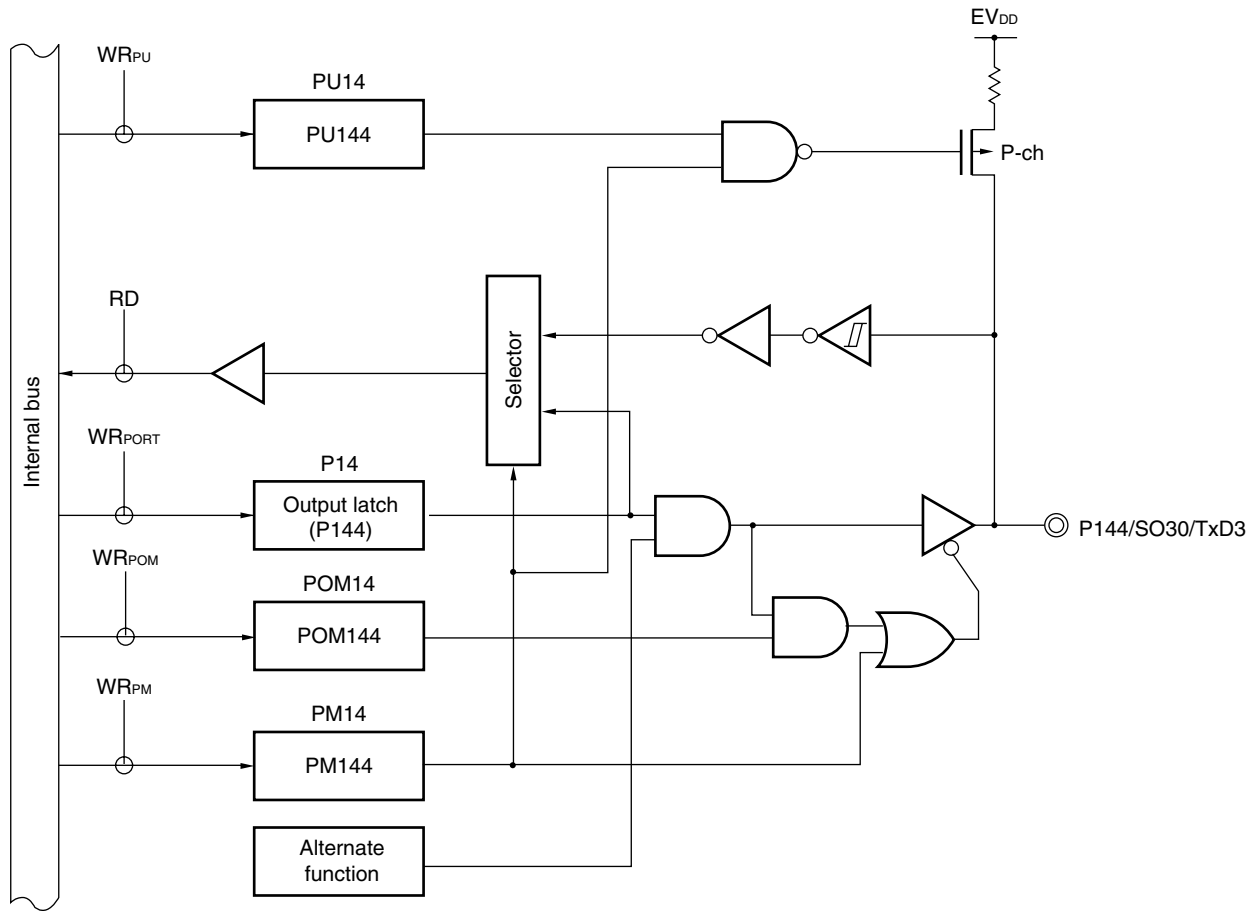
- P14: Port register 14
- PU14: Pull-up resistor option register 14
- PM14: Port mode register 14
- PIM14: Port input mode register 14
- POM14: Port output mode register 14
- RD: Read signal
- WR<sub>xx</sub>: Write signal

Figure 4-59. Block Diagram of P143



- P14: Port register 14
- PU14: Pull-up resistor option register 14
- PM14: Port mode register 14
- PIM14: Port input mode register 14
- POM14: Port output mode register 14
- RD: Read signal
- WR<sub>xx</sub>: Write signal

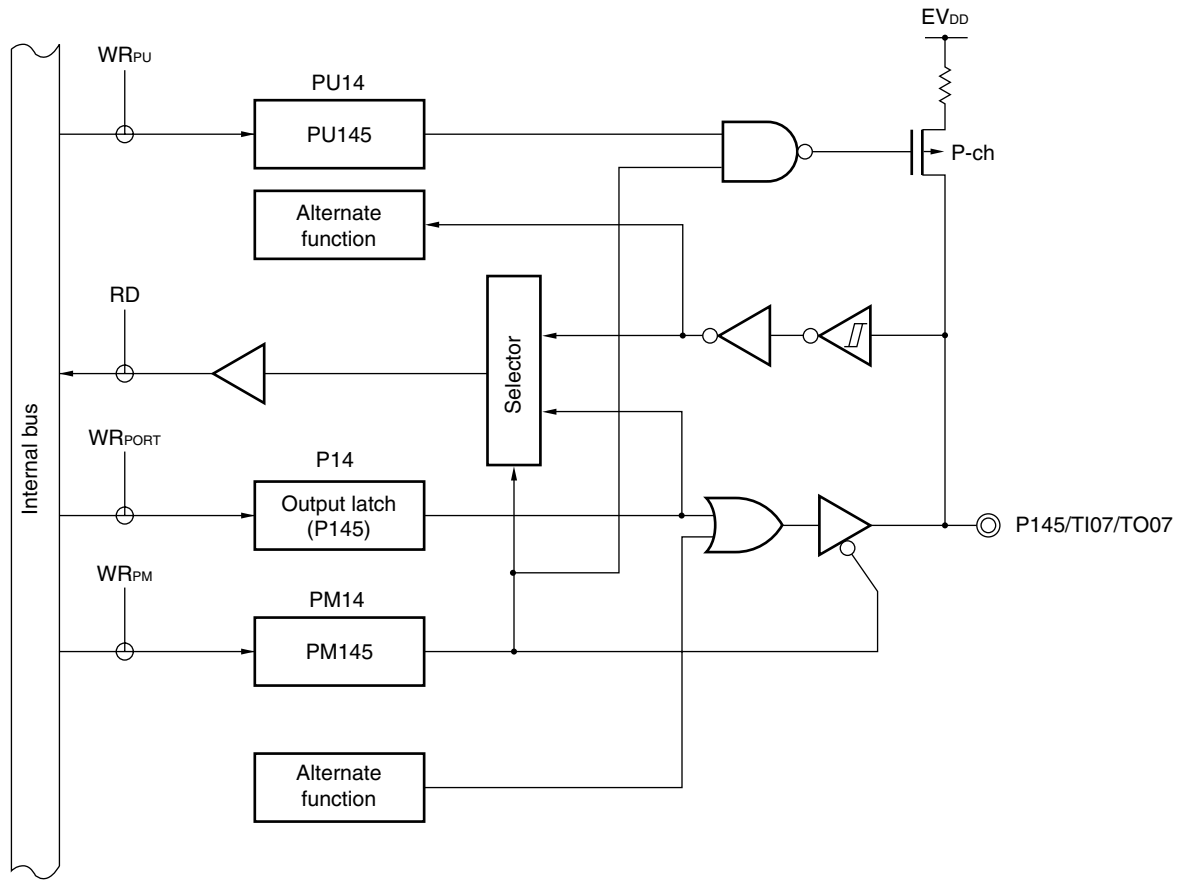
Figure 4-60. Block Diagram of P144



- P14: Port register 14
- PU14: Pull-up resistor option register 14
- PM14: Port mode register 14
- POM14: Port output mode register 14
- RD: Read signal
- WR<sub>xx</sub>: Write signal

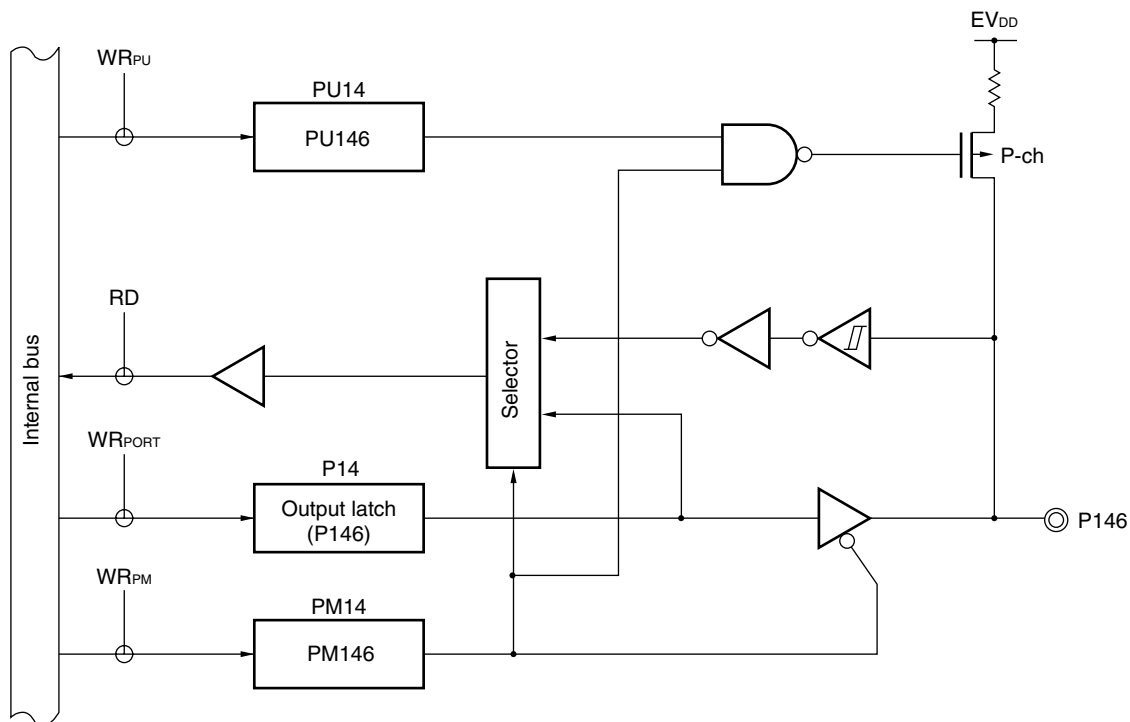


Figure 4-61. Block Diagram of P145



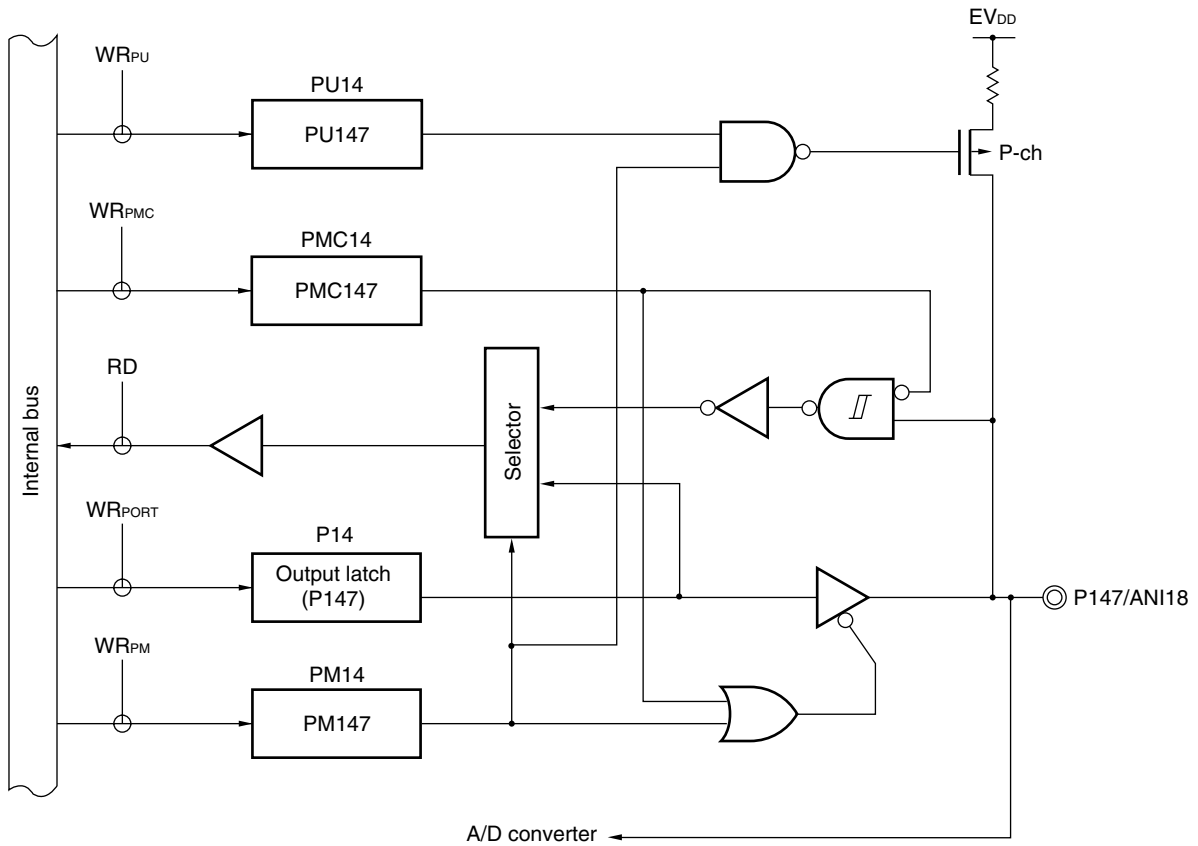
- P14: Port register 14
- PU14: Pull-up resistor option register 14
- PM14: Port mode register 14
- RD: Read signal
- WR<sub>xx</sub>: Write signal

Figure 4-62. Block Diagram of P146



- P14: Port register 14
- PU14: Pull-up resistor option register 14
- PM14: Port mode register 14
- RD: Read signal
- WR<sub>xx</sub>: Write signal

Figure 4-63. Block Diagram of P147



- P14: Port register 14
- PU14: Pull-up resistor option register 14
- PM14: Port mode register 14
- PMC14: Port mode control register 14
- RD: Read signal
- WR<sub>xx</sub>: Write signal

**4.2.16 Port 15**

Port 15 is an I/O port with an output latch. Port 15 can be set to the input mode or output mode in 1-bit units using port mode register 15 (PM15).

This port can also be used for A/D converter analog input.

To use P150/ANI8 to P156/ANI4 as digital input pins, set them in the digital I/O mode by using the A/D port configuration register (ADPC) and in the input mode by using the PM15 register. Use these pins starting from the upper bit.

To use P150/ANI8 to P156/ANI4 as digital output pins, set them in the digital I/O mode by using the ADPC register and in the output mode by using the PM15 register.

To use P150/ANI8 to P156/ANI4 as analog input pins, set them in the analog input mode by using the A/D port configuration register (ADPC) and in the input mode by using the PM15 register. Use these pins starting from the lower bit.

<R>

**Table 4-19. Settings of Registers When Using Port 15**

Pin Name		PM15 <sub>x</sub>	ADPC	Alternate Function Setting	Remark
Name	I/O				
P15n	Input	1	01H to n+9H	-	To use P15n as a port, use these pins from a higher bit.
	Output	0			

- Remarks 1.** ×: don't care  
 PM15<sub>x</sub>: Port mode register 15  
 ADPC: A/D port configuration register
- 2.** n = 0 to 6

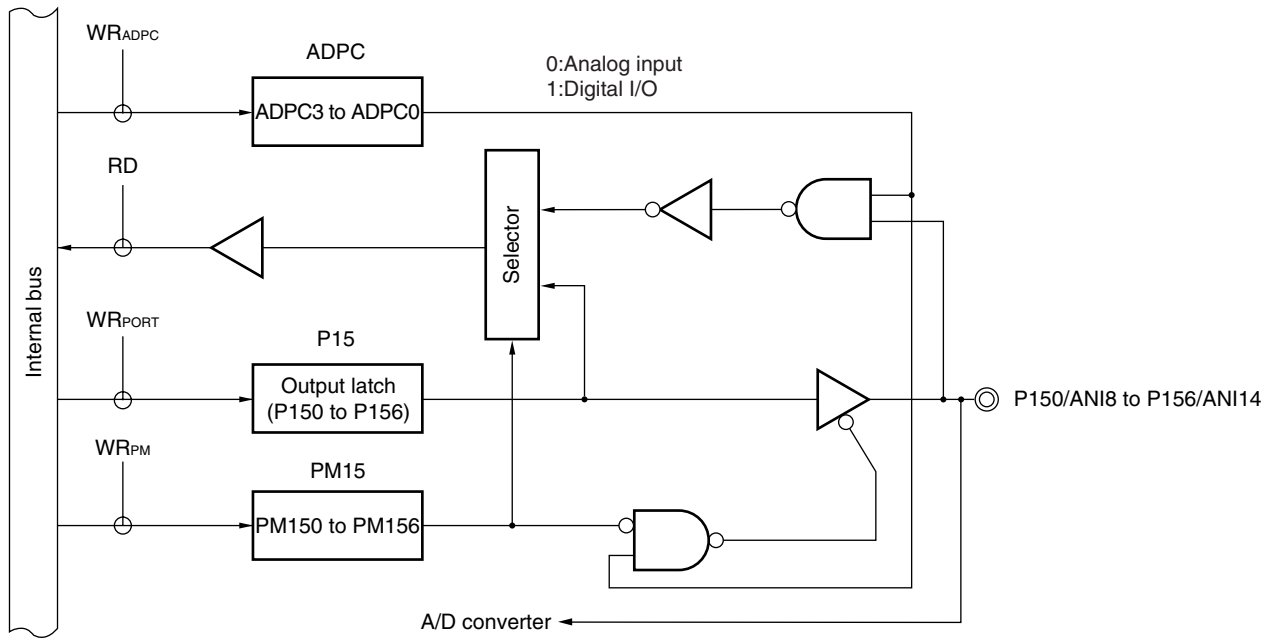
**Table 4-20. Setting Functions of P150/ANI8 to P156/ANI14 Pins**

ADPC Register	PM15 Register	ADS Register	P150/ANI8 to P156/ANI14 Pins
Digital I/O selection	Input mode	-	Digital input
	Output mode	-	Digital output
Analog input selection	Input mode	Selects ANI.	Analog input (to be converted)
		Does not select ANI.	Analog input (not to be converted)
	Output mode	Selects ANI.	Setting prohibited
		Does not select ANI.	

All P150/ANI8 to P156/ANI14 are set in the analog input mode when the reset signal is generated. Figure 4-64 shows a block diagram of port 15.

<R>

Figure 4-64. Block Diagram of P150 to P156



- ADPC: A/D port configuration register
- P15: Port register 15
- PM15: Port mode register 15
- RD: Read signal
- WR<sub>xx</sub>: Write signal

### 4.3 Registers Controlling Port Function

Port functions are controlled by the following registers.

- Port mode registers (PMxx)
- Port registers (Pxx)
- Pull-up resistor option registers (PUxx)
- Port input mode registers (PIMxx)
- Port output mode registers (POMxx)
- Port mode control registers (PMCxx)
- A/D port configuration register (ADPC)
- Peripheral I/O redirection register (PIOR)
- Global digital input disable register (GDIDIS)

<R> **Table 4-21. PMxx, Pxx, PUxx, PIMxx, POMxx, PMCxx registers and the bits mounted on each product (20-pin products to 64-pin products) (1/3)**

Port	Bit name						64 pin	52 pin	48 pin	44 pin	40 pin	36 pin	32 pin	30 pin	25 pin	24 pin	20 pin
	PMxx register	Pxx register	PUxx register	PIMxx register	POMxx register	PMCxx register											
Port 0	0	PM00	P00	PU00	–	POM00	PMC00 <sup>Note1</sup>	√	√	√	√	√	√	√	√	√	√
	1	PM01	P01	PU01	PIM01	–	PMC01 <sup>Note1</sup>	√	√	√	√	√	√	√	√	√	√
	2	PM02	P02	PU02	–	POM02	PMC02	√	√	–	–	–	–	–	–	–	–
	3	PM03	P03	PU03	PIM03	POM03 <sup>Note2</sup>	PMC03	√	√	–	–	–	–	–	–	–	–
	4	PM04	P04	PU04	PIM04	POM04	–	√	–	–	–	–	–	–	–	–	–
	5	PM05	P05	PU05	–	–	–	√	–	–	–	–	–	–	–	–	–
	6	PM06	P06	PU06	–	–	–	√	–	–	–	–	–	–	–	–	–
	7	–	–	–	–	–	–	–	–	–	–	–	–	–	–	–	–
Port 1	0	PM10	P10	PU10	PIM10	POM10	–	√	√	√	√	√	√	√	√	√	√
	1	PM11	P11	PU11	PIM11	POM11	–	√	√	√	√	√	√	√	√	√	√
	2	PM12	P12	PU12	–	POM12	–	√	√	√	√	√	√	√	√	√	√
	3	PM13	P13	PU13	PIM13	POM13	–	√	√	√	√	√	√	√	–	–	–
	4	PM14	P14	PU14	PIM14	POM14	–	√	√	√	√	√	√	√	–	–	–
	5	PM15	P15	PU15	PIM15	POM15	–	√	√	√	√	√	√	√	–	–	–
	6	PM16	P16	PU16	PIM16	–	–	√	√	√	√	√	√	√	√	√	√
	7	PM17	P17	PU17	PIM17	POM17	–	√	√	√	√	√	√	√	√	√	√
Port 2	0	PM20	P20	–	–	–	–	√	√	√	√	√	√	√	√	√	√
	1	PM21	P21	–	–	–	–	√	√	√	√	√	√	√	√	√	√
	2	PM22	P22	–	–	–	–	√	√	√	√	√	√	√	√	√	√
	3	PM23	P23	–	–	–	–	√	√	√	√	√	√	√	–	–	–
	4	PM24	P24	–	–	–	–	√	√	√	√	√	–	–	–	–	–
	5	PM25	P25	–	–	–	–	√	√	√	√	√	–	–	–	–	–
	6	PM26	P26	–	–	–	–	√	√	√	√	√	–	–	–	–	–
	7	PM27	P27	–	–	–	–	√	√	√	√	–	–	–	–	–	–

**Notes** 1. 20-pin, 24-pin, 25-pin, 30-pin, and 32-pin products only.  
 2. 64-pin products only.

<R> **Table 4-21. PMxx, Pxx, PUxx, PIMxx, POMxx, PMCxx registers and the bits mounted on each product**  
**(20-pin products to 64-pin products) (2/3)**

Port		Bit name						64 pin	52 pin	48 pin	44 pin	40 pin	36 pin	32 pin	30 pin	25 pin	24 pin	20 pin
		PMxx register	Pxx register	PUxx register	PIMxx register	POMxx register	PMCxx register											
Port 3	0	PM30	P30	PU30	-	-	-	√	√	√	√	√	√	√	√	√	√	√
	1	PM31	P31	PU31	-	-	-	√	√	√	√	√	√	√	√	√	√	-
	2	-	-	-	-	-	-	-	-	-	-	-	-	-	-	-	-	-
	3	-	-	-	-	-	-	-	-	-	-	-	-	-	-	-	-	-
	4	-	-	-	-	-	-	-	-	-	-	-	-	-	-	-	-	-
	5	-	-	-	-	-	-	-	-	-	-	-	-	-	-	-	-	-
	6	-	-	-	-	-	-	-	-	-	-	-	-	-	-	-	-	-
	7	-	-	-	-	-	-	-	-	-	-	-	-	-	-	-	-	-
Port 4	0	PM40	P40	PU40	-	-	-	√	√	√	√	√	√	√	√	√	√	√
	1	PM41	P41	PU41	-	-	-	√	√	√	√	-	-	-	-	-	-	-
	2	PM42	P42	PU42	-	-	-	√	-	-	-	-	-	-	-	-	-	-
	3	PM43	P43	PU43	PIM43	POM43	-	√	-	-	-	-	-	-	-	-	-	-
	4	-	-	-	-	-	-	-	-	-	-	-	-	-	-	-	-	-
	5	-	-	-	-	-	-	-	-	-	-	-	-	-	-	-	-	-
	6	-	-	-	-	-	-	-	-	-	-	-	-	-	-	-	-	-
	7	-	-	-	-	-	-	-	-	-	-	-	-	-	-	-	-	-
Port 5	0	PM50	P50	PU50	-	POM50	-	√	√	√	√	√	√	√	√	√	√	-
	1	PM51	P51	PU51	-	-	-	√	√	-	√	√	√	√	√	-	-	-
	2	PM52	P52	PU52	-	-	-	√	-	-	-	-	-	-	-	-	-	-
	3	PM53	P53	PU53	-	-	-	√	-	-	-	-	-	-	-	-	-	-
	4	PM54	P54	PU54	-	-	-	√	-	-	-	-	-	-	-	-	-	-
	5	PM55	P55	PU55	PIM55	POM55	-	√	-	-	-	-	-	-	-	-	-	-
	6	-	-	-	-	-	-	-	-	-	-	-	-	-	-	-	-	-
	7	-	-	-	-	-	-	-	-	-	-	-	-	-	-	-	-	-
Port 6	0	PM60	P60	-	-	-	-	√	√	√	√	√	√	√	√	√	√	-
	1	PM61	P61	-	-	-	-	√	√	√	√	√	√	√	√	√	√	-
	2	PM62	P62	-	-	-	-	√	√	√	√	√	√	√	-	-	-	-
	3	PM63	P63	-	-	-	-	√	√	√	√	-	-	-	-	-	-	-
	4	-	-	-	-	-	-	-	-	-	-	-	-	-	-	-	-	-
	5	-	-	-	-	-	-	-	-	-	-	-	-	-	-	-	-	-
	6	-	-	-	-	-	-	-	-	-	-	-	-	-	-	-	-	-
	7	-	-	-	-	-	-	-	-	-	-	-	-	-	-	-	-	-
Port 7	0	PM70	P70	PU70	-	-	-	√	√	√	√	√	√	√	-	-	-	-
	1	PM71	P71	PU71	-	POM71	-	√	√	√	√	√	√	-	-	-	-	-
	2	PM72	P72	PU72	-	-	-	√	√	√	√	√	√	-	-	-	-	-
	3	PM73	P73	PU73	-	-	-	√	√	√	√	√	-	-	-	-	-	-
	4	PM74	P74	PU74	-	POM74	-	√	√	√	-	-	-	-	-	-	-	-
	5	PM75	P75	PU75	-	-	-	√	√	√	-	-	-	-	-	-	-	-
	6	PM76	P76	PU76	-	-	-	√	√	-	-	-	-	-	-	-	-	-
	7	PM77	P77	PU77	-	-	-	√	√	-	-	-	-	-	-	-	-	-

**Table 4-21. PMxx, Pxx, PUxx, PIMxx, POMxx, PMCxx registers and the bits mounted on each product  
(20-pin products to 64-pin products) (3/3)**

Port	Bit name						64 pin	52 pin	48 pin	44 pin	40 pin	36 pin	32 pin	30 pin	25 pin	24 pin	20 pin
	PMxx register	Pxx register	PUxx register	PIMxx register	POMxx register	PMCxx register											
Port 8	-	-	-	-	-	-	-	-	-	-	-	-	-	-	-	-	-
Port 9	-	-	-	-	-	-	-	-	-	-	-	-	-	-	-	-	-
Port 10	-	-	-	-	-	-	-	-	-	-	-	-	-	-	-	-	-
Port 11	-	-	-	-	-	-	-	-	-	-	-	-	-	-	-	-	-
Port 12	0	PM120	P120	PU120	-	-	PMC120	√	√	√	√	√	√	√	-	-	-
	1	-	P121	-	-	-	-	√	√	√	√	√	√	√	√	√	√
	2	-	P122	-	-	-	-	√	√	√	√	√	√	√	√	√	√
	3	-	P123	-	-	-	-	√	√	√	√	√	-	-	-	-	-
	4	-	P124	-	-	-	-	√	√	√	√	√	-	-	-	-	-
	5	-	-	-	-	-	-	-	-	-	-	-	-	-	-	-	-
	6	-	-	-	-	-	-	-	-	-	-	-	-	-	-	-	-
	7	-	-	-	-	-	-	-	-	-	-	-	-	-	-	-	-
Port 13	0	-	P130	-	-	-	-	√	√	√	-	-	-	-	-	√	-
	1	-	-	-	-	-	-	-	-	-	-	-	-	-	-	-	-
	2	-	-	-	-	-	-	-	-	-	-	-	-	-	-	-	-
	3	-	-	-	-	-	-	-	-	-	-	-	-	-	-	-	-
	4	-	-	-	-	-	-	-	-	-	-	-	-	-	-	-	-
	5	-	-	-	-	-	-	-	-	-	-	-	-	-	-	-	-
	6	-	-	-	-	-	-	-	-	-	-	-	-	-	-	-	-
	7	-	-	P137	-	-	-	-	√	√	√	√	√	√	√	√	√
Port 14	0	PM140	P140	PU140	-	-	-	√	√	√	-	-	-	-	-	-	-
	1	PM141	P141	PU141	-	-	-	√	-	-	-	-	-	-	-	-	-
	2	-	-	-	-	-	-	-	-	-	-	-	-	-	-	-	-
	3	-	-	-	-	-	-	-	-	-	-	-	-	-	-	-	-
	4	-	-	-	-	-	-	-	-	-	-	-	-	-	-	-	-
	5	-	-	-	-	-	-	-	-	-	-	-	-	-	-	-	-
	6	PM146	P146	PU146	-	-	-	√	√	√	√	-	-	-	-	-	-
	7	PM147	P147	PU147	-	-	-	PMC147	√	√	√	√	√	√	√	√	√
Port 15	-	-	-	-	-	-	-	-	-	-	-	-	-	-	-	-	



**Table 4-22. PMxx, Pxx, PUxx, PIMxx, POMxx, PMCxx registers and the bits mounted on each product  
(80-pin products to 128-pin products) (1/4)**

Port		Bit name						128 pin	100 pin	80 pin
		PMxx register	Pxx register	PUxx register	PIMxx register	POMxx register	PMCxx register			
Port 0	0	PM00	P00	PU00	–	POM00	–	√	√	√
	1	PM01	P01	PU01	PIM01	–	–	√	√	√
	2	PM02	P02	PU02	–	POM02	PMC02	√	√	√
	3	PM03	P03	PU03	PIM03	POM03	PMC03	√	√	√
	4	PM04	P04	PU04	PIM04	POM04	–	√	√	√
	5	PM05	P05	PU05	–	–	–	√	√	√
	6	PM06	P06	PU06	–	–	–	√	√	√
	7	PM07	P07	PU07	–	–	–	√	–	–
Port 1	0	PM10	P10	PU10	PIM10	POM10	–	√	√	√
	1	PM11	P11	PU11	PIM11	POM11	–	√	√	√
	2	PM12	P12	PU12	–	POM12	–	√	√	√
	3	PM13	P13	PU13	PIM13	POM13	–	√	√	√
	4	PM14	P14	PU14	PIM14	POM14	–	√	√	√
	5	PM15	P15	PU15	PIM15	POM15	–	√	√	√
	6	PM16	P16	PU16	PIM16	–	–	√	√	√
	7	PM17	P17	PU17	PIM17	POM17	–	√	√	√
Port 2	0	PM20	P20	–	–	–	–	√	√	√
	1	PM21	P21	–	–	–	–	√	√	√
	2	PM22	P22	–	–	–	–	√	√	√
	3	PM23	P23	–	–	–	–	√	√	√
	4	PM24	P24	–	–	–	–	√	√	√
	5	PM25	P25	–	–	–	–	√	√	√
	6	PM26	P26	–	–	–	–	√	√	√
	7	PM27	P27	–	–	–	–	√	√	√
Port 3	0	PM30	P30	PU30	–	–	–	√	√	√
	1	PM31	P31	PU31	–	–	–	√	√	√
	2	PM32	P32	PU32	–	–	–	√	–	–
	3	PM33	P33	PU33	–	–	–	√	–	–
	4	PM34	P34	PU34	–	–	–	√	–	–
	5	PM35	P35	PU35	–	–	PMC35	√	–	–
	6	PM36	P36	PU36	–	–	PMC36	√	–	–
	7	PM37	P37	PU37	–	–	PMC37	√	–	–

**Table 4-22. PMxx, Pxx, PUxx, PIMxx, POMxx, PMCxx registers and the bits mounted on each product  
(80-pin products to 128-pin products) (2/4)**

Port		Bit name					128 pin	100 pin	80 pin	
		PMxx register	Pxx register	PUxx register	PIMxx register	POMxx register				PMCxx register
Port 4	0	PM40	P40	PU40	–	–	–	√	√	√
	1	PM41	P41	PU41	–	–	–	√	√	√
	2	PM42	P42	PU42	–	–	–	√	√	√
	3	PM43	P43	PU43	PIM43	POM43	–	√	√	√
	4	PM44	P44	PU44	PIM44	POM44	–	√	√	√
	5	PM45	P45	PU45	–	POM45	–	√	√	√
	6	PM46	P46	PU46	–	–	–	√	√	–
	7	PM47	P47	PU47	–	–	–	√	√	–
Port 5	0	PM50	P50	PU50	–	POM50	–	√	√	√
	1	PM51	P51	PU51	–	–	–	√	√	√
	2	PM52	P52	PU52	–	POM52	–	√	√	√
	3	PM53	P53	PU53	PIM53	POM53	–	√	√	√
	4	PM54	P54	PU54	PIM54	POM54	–	√	√	√
	5	PM55	P55	PU55	PIM55	POM55	–	√	√	√
	6	PM56	P56	PU56	–	–	–	√	√	–
	7	PM57	P57	PU57	–	–	–	√	√	–
Port 6	0	PM60	P60	–	–	–	–	√	√	√
	1	PM61	P61	–	–	–	–	√	√	√
	2	PM62	P62	–	–	–	–	√	√	√
	3	PM63	P63	–	–	–	–	√	√	√
	4	PM64	P64	PU64	–	–	–	√	√	√
	5	PM65	P65	PU65	–	–	–	√	√	√
	6	PM66	P66	PU66	–	–	–	√	√	√
	7	PM67	P67	PU67	–	–	–	√	√	√
Port 7	0	PM70	P70	PU70	–	–	–	√	√	√
	1	PM71	P71	PU71	–	POM71	–	√	√	√
	2	PM72	P72	PU72	–	–	–	√	√	√
	3	PM73	P73	PU73	–	–	–	√	√	√
	4	PM74	P74	PU74	–	POM74	–	√	√	√
	5	PM75	P75	PU75	–	–	–	√	√	√
	6	PM76	P76	PU76	–	–	–	√	√	√
	7	PM77	P77	PU77	–	–	–	√	√	√
Port 8	0	PM80	P80	PU80	PIM80	POM80	–	√	√	–
	1	PM81	P81	PU81	PIM81	POM81	–	√	√	–
	2	PM82	P82	PU82	–	POM82	–	√	√	–
	3	PM83	P83	PU83	–	–	–	√	√	–
	4	PM84	P84	PU84	–	–	–	√	√	–
	5	PM85	P85	PU85	–	–	–	√	√	–
	6	PM86	P86	PU86	–	–	–	√	√	–
	7	PM87	P87	PU87	–	–	–	√	√	–

<R> **Table 4-22. PMxx, Pxx, PUxx, PIMxx, POMxx, PMCxx registers and the bits mounted on each product (80-pin products to 128-pin products) (3/4)**

Port		Bit name						128 pin	100 pin	80 pin
		PMxx register	Pxx register	PUxx register	PIMxx register	POMxx register	PMCxx register			
Port 9	0	PM90	P90	PU90	-	-	-	√	-	-
	1	PM91	P91	PU91	-	-	-	√	-	-
	2	PM92	P92	PU92	-	-	-	√	-	-
	3	PM93	P93	PU93	-	-	-	√	-	-
	4	PM94	P94	PU94	-	-	-	√	-	-
	5	PM95	P95	PU95	-	-	-	√	-	-
	6	PM96	P96	PU96	-	POM96	-	√	-	-
	7	PM97	P97	PU97	-	-	-	√	-	-
Port 10	0	PM100	P100	PU100	-	-	PMC100	√	√	√
	1	PM101	P101	PU101	-	-	-	√	√	-
	2	PM102	P102	PU102	-	-	-	√	√	-
	3	PM103	P103	PU103	-	-	-	√	-	-
	4	PM104	P104	PU104	-	-	-	√	-	-
	5	PM105	P105	PU105	-	-	-	√	-	-
	6	PM106	P106	PU106	-	-	-	√	-	-
	7	-	-	-	-	-	-	-	-	-
Port 11	0	PM110	P110	PU110	-	-	-	√	√	√
	1	PM111	P111	PU111	-	-	-	√	√	√
	2	PM112	P112	PU112	-	-	-	√	-	-
	3	PM113	P113	PU113	-	-	-	√	-	-
	4	PM114	P114	PU114	-	-	-	√	-	-
	5	PM115	P115	PU115	-	-	PMC115	√	-	-
	6	PM116	P116	PU116	-	-	PMC116	√	-	-
	7	PM117	P117	PU117	-	-	PMC117	√	-	-
Port 12	0	PM120	P120	PU120	-	-	PMC120	√	√	√
	1	-	P121	-	-	-	-	√	√	√
	2	-	P122	-	-	-	-	√	√	√
	3	-	P123	-	-	-	-	√	√	√
	4	-	P124	-	-	-	-	√	√	√
	5	PM125	P125	PU125	-	-	-	√	-	-
	6	PM126	P126	PU126	-	-	-	√	-	-
	7	PM127	P127	PU127	-	-	-	√	-	-
Port 13	0	-	P130	-	-	-	-	√	√	√
	1	-	-	-	-	-	-	-	-	-
	2	-	-	-	-	-	-	-	-	-
	3	-	-	-	-	-	-	-	-	-
	4	-	-	-	-	-	-	-	-	-
	5	-	-	-	-	-	-	-	-	-
	6	-	-	-	-	-	-	-	-	-
	7	-	P137	-	-	-	-	√	√	√

**Table 4-22. PMxx, Pxx, PUxx, PIMxx, POMxx, PMCxx registers and the bits mounted on each product  
(80-pin products to 128-pin products) (4/4)**

Port		Bit name						128 pin	100 pin	80 pin
		PMxx register	Pxx register	PUxx register	PIMxx register	POMxx register	PMCxx register			
Port 14	0	PM140	P140	PU140	–	–	–	√	√	√
	1	PM141	P141	PU141	–	–	–	√	√	√
	2	PM142	P142	PU142	PIM142	POM142	–	√	√	√
	3	PM143	P143	PU143	PIM143	POM143	–	√	√	√
	4	PM144	P144	PU144		POM144	–	√	√	√
	5	PM145	P145	PU145	–	–	–	√	√	–
	6	PM146	P146	PU146	–	–	–	√	√	√
	7	PM147	P147	PU147	–	–	PMC147	√	√	√
Port 15	0	PM150	P150	–	–	–	–	√	√	√
	1	PM151	P151	–	–	–	–	√	√	√
	2	PM152	P152	–	–	–	–	√	√	√
	3	PM153	P153	–	–	–	–	√	√	√
	4	PM154	P154	–	–	–	–	√	√	–
	5	PM155	P155	–	–	–	–	√	√	–
	6	PM156	P156	–	–	–	–	√	√	–
	7	–	–	–	–	–	–	–	–	–

The format of each register is described below. The description here uses the 128-pin products as an example.

<R> For the registers mounted on others than 128-pin products, refer to **table 4-21** and **4-22**.

**(1) Port mode registers (PMxx)**

These registers specify input or output mode for the port in 1-bit units.

These registers can be set by a 1-bit or 8-bit memory manipulation instruction.

Reset signal generation sets these registers to FFH.

When port pins are used as alternate-function pins, set the port mode register by referencing **4.5 Settings of Port Mode Register, and Output Latch When Using Alternate Function**.

Figure 4-65. Format of Port Mode Register (128-pin products)

Symbol	7	6	5	4	3	2	1	0	Address	After reset	R/W
PM0	PM07	PM06	PM05	PM04	PM03	PM02	PM01	PM00	FFF20H	FFH	R/W
PM1	PM17	PM16	PM15	PM14	PM13	PM12	PM11	PM10	FFF21H	FFH	R/W
PM2	PM27	PM26	PM25	PM24	PM23	PM22	PM21	PM20	FFF22H	FFH	R/W
PM3	PM37	PM36	PM35	PM34	PM33	PM32	PM31	PM30	FFF23H	FFH	R/W
PM4	PM47	PM46	PM45	PM44	PM43	PM42	PM41	PM40	FFF24H	FFH	R/W
PM5	PM57	PM56	PM55	PM54	PM53	PM52	PM51	PM50	FFF25H	FFH	R/W
PM6	PM67	PM66	PM65	PM64	PM63	PM62	PM61	PM60	FFF26H	FFH	R/W
PM7	PM77	PM76	PM75	PM74	PM73	PM72	PM71	PM70	FFF27H	FFH	R/W
PM8	PM87	PM86	PM85	PM84	PM83	PM82	PM81	PM80	FFF28H	FFH	R/W
PM9	PM97	PM96	PM95	PM94	PM93	PM92	PM91	PM90	FFF29H	FFH	R/W
PM10	1	PM106	PM105	PM104	PM103	PM102	PM101	PM100	FFF2AH	FFH	R/W
PM11	PM117	PM116	PM115	PM114	PM113	PM112	PM111	PM110	FFF2BH	FFH	R/W
PM12	PM127	PM126	PM125	1	1	1	1	PM120	FFF2CH	FFH	R/W
PM14	PM147	PM146	PM145	PM144	PM143	PM142	PM141	PM140	FFF2EH	FFH	R/W
PM15	1	PM156	PM155	PM154	PM153	PM152	PM151	PM150	FFF2FH	FFH	R/W

PMmn	<p>PMn pin I/O mode selection (m = 0 to 12, 14, 15; n = 0 to 7)</p>
0	Output mode (output buffer on)
1	Input mode (output buffer off)

**Caution** Be sure to set bit 7 of the PM10 register, bits 1 to 4 of the PM12 register, and bit 7 of the PM15 register to “1”.

**(2) Port registers (Pxx)**

These registers set the output latch value of a port.

If the data is read in the input mode, the pin level is read. If it is read in the output mode, the output latch value is read<sup>Note</sup>.

These registers can be set by a 1-bit or 8-bit memory manipulation instruction.

Reset signal generation clears these registers to 00H.

**Note** If P02, P03, P20 to P27, P35 to P37, P100, P115 to P117, P120, P147, and P150 to P156 are set up as analog inputs of the A/D converter, when a port is read while in the input mode, 0 is always returned, not the pin level.

Figure 4-66. Format of Port Register (128-pin products)

Symbol	7	6	5	4	3	2	1	0	Address	After reset	R/W
P0	P07	P06	P05	P04	P03	P02	P01	P00	FFF00H	00H (output latch)	R/W
P1	P17	P16	P15	P14	P13	P12	P11	P10	FFF01H	00H (output latch)	R/W
P2	P27	P26	P25	P24	P23	P22	P21	P20	FFF02H	00H (output latch)	R/W
P3	P37	P36	P35	P34	P33	P32	P31	P30	FFF03H	00H (output latch)	R/W
P4	P47	P46	P45	P44	P43	P42	P41	P40	FFF04H	00H (output latch)	R/W
P5	P57	P56	P55	P54	P53	P52	P51	P50	FFF05H	00H (output latch)	R/W
P6	P67	P66	P65	P64	P63	P62	P61	P60	FFF06H	00H (output latch)	R/W
P7	P77	P76	P75	P74	P73	P72	P71	P70	FFF07H	00H (output latch)	R/W
P8	P87	P86	P85	P84	P83	P82	P81	P80	FFF08H	00H (output latch)	R/W
P9	P97	P96	P95	P94	P93	P92	P91	P90	FFF09H	00H (output latch)	R/W
P10	0	P106	P105	P104	P103	P102	P101	P100	FFF0AH	00H (output latch)	R/W
P11	P117	P116	P115	P114	P113	P112	P111	P110	FFF0BH	00H (output latch)	R/W
P12	P127	P126	P125	P124	P123	P122	P121	P120	FFF0CH	Undefined	R/W <sup>Note</sup>
P13	P137	0	0	0	0	0	0	P130	FFF0DH	Undefined	R/W <sup>Note</sup>
P14	P147	P146	P145	P144	P143	P142	P141	P140	FFF0EH	00H (output latch)	R/W
P15	0	P156	P155	P154	P153	P152	P151	P150	FFF0FH	00H (output latch)	R/W

Pmn	m = 0 to 15; n = 0 to 7	
	Output data control (in output mode)	Input data read (in input mode)
0	Output 0	Input low level
1	Output 1	Input high level

**Note** P121 to P124, and P137 are read-only.



**(3) Pull-up resistor option registers (PUxx)**

These registers specify whether the on-chip pull-up resistors are to be used or not. On-chip pull-up resistors can be used in 1-bit units only for the bits set to input mode (PMmn = 1 and POMmn = 0) for the pins to which the use of an on-chip pull-up resistor has been specified in these registers. On-chip pull-up resistors cannot be connected to bits set to output mode and bits used as alternate-function output pins, regardless of the settings of these registers.

These registers can be set by a 1-bit or 8-bit memory manipulation instruction. Reset signal generation clears these registers to 00H (Only PU4 is set to 01H).

**Figure 4-67. Format of Pull-up Resistor Option Register (128-pin products)**

Symbol	7	6	5	4	3	2	1	0	Address	After reset	R/W
PU0	PU07	PU06	PU05	PU04	PU03	PU02	PU01	PU00	F0030H	00H	R/W
PU1	PU17	PU16	PU15	PU14	PU13	PU12	PU11	PU10	F0031H	00H	R/W
PU3	PU37	PU36	PU35	PU34	PU33	PU32	PU31	PU30	F0033H	00H	R/W
PU4	PU47	PU46	PU45	PU44	PU43	PU42	PU41	PU40	F0034H	01H	R/W
PU5	PU57	PU56	PU55	PU54	PU53	PU52	PU51	PU50	F0035H	00H	R/W
PU6	PU67	PU66	PU65	PU64	0	0	0	0	F0036H	00H	R/W
PU7	PU77	PU76	PU75	PU74	PU73	PU72	PU71	PU70	F0037H	00H	R/W
PU8	PU87	PU86	PU85	PU84	PU83	PU82	PU81	PU80	F0038H	00H	R/W
PU9	PU97	PU96	PU95	PU94	PU93	PU92	PU91	PU90	F0039H	00H	R/W
PU10	0	PU106	PU105	PU104	PU103	PU102	PU101	PU100	F003AH	00H	R/W
PU11	PU117	PU116	PU115	PU114	PU113	PU112	PU111	PU110	F003BH	00H	R/W
PU12	PU127	PU126	PU125	0	0	0	0	PU120	F003CH	00H	R/W
PU14	PU147	PU146	PU145	PU144	PU143	PU142	PU141	PU140	F003EH	00H	R/W

PUmn	Pmn pin on-chip pull-up resistor selection (m = 0, 1, 3 to 12, 14; n = 0 to 7)
0	On-chip pull-up resistor not connected
1	On-chip pull-up resistor connected

**(4) Port input mode registers (PIM0, PIM1, PIM4, PIM5, PIM8, PIM14)**

These registers set the input buffer of P01, P03, P04, P10, P11, P13 to P17, P43, P44, P53 to P55, P80, P81, P142, and P143 in 1-bit units.

TTL input buffer can be selected during serial communication with an external device of the different potential.

These registers can be set by a 1-bit or 8-bit memory manipulation instruction.

Reset signal generation clears these registers to 00H.

**Figure 4-68. Format of Port Input Mode Register (128-pin products)**

Symbol	7	6	5	4	3	2	1	0	Address	After reset	R/W
PIM0	0	0	0	PIM04	PIM03	0	PIM01	0	F0040H	00H	R/W
PIM1	PIM17	PIM16	PIM15	PIM14	PIM13	0	PIM11	PIM10	F0041H	00H	R/W
PIM4	0	0	0	PIM44	PIM43	0	0	0	F0044H	00H	R/W
PIM5	0	0	PIM55	PIM54	PIM53	0	0	0	F0045H	00H	R/W
PIM8	0	0	0	0	0	0	PIM81	PIM80	F0048H	00H	R/W
PIM14	0	0	0	0	PIM143	PM142	0	0	F004EH	00H	R/W

PIMmn	Pmn pin input buffer selection (m = 0, 1, 4, 5, 8, 14; n = 0 to 7)	
0	Normal input buffer	
1	TTL input buffer	

**(5) Port output mode registers (POM0, POM1, POM4, POM5, POM7 to POM9, POM14)**

These registers set the output mode of P00, P02 to P04, P10 to P15, P17, P43 to P45, P50, P52 to P55, P71, P74, P80 to P82, P96, P142 to P144 in 1-bit units.

N-ch open drain output ( $V_{DD}$  tolerance) mode can be selected during serial communication with an external device of the different potential, and for the SDA00, SDA01, SDA10, SDA11, SDA20, SDA21, SDA30, and SDA31 pins during simplified I<sup>2</sup>C communication with an external device of the same potential.

These registers can be set by a 1-bit or 8-bit memory manipulation instruction.

Reset signal generation clears these registers to 00H.

**Figure 4-69. Format of Port Input Mode Register (128-pin products)**

Symbol	7	6	5	4	3	2	1	0	Address	After reset	R/W
POM0	0	0	0	POM04	POM03	POM02	0	POM00	F0050H	00H	R/W
POM1	POM17	0	POM15	POM14	POM13	POM12	POM11	POM10	F0051H	00H	R/W
POM4	0	0	POM45	POM44	POM43	0	0	0	F0054H	00H	R/W
POM5	0	0	POM55	POM54	POM53	POM52	0	POM50	F0055H	00H	R/W
POM7	0	0	0	POM74	0	0	POM71	0	F0057H	00H	R/W
POM8	0	0	0	0	0	POM82	POM81	POM80	F0058H	00H	R/W
POM9	0	POM96	0	0	0	0	0	0	F0059H	00H	R/W
POM14	0	0	0	POM144	POM143	POM142	0	0	F005EH	00H	R/W

POMmn	Pmn pin output mode selection (m = 0, 1, 4, 5, 7 to 9, 14; n = 0 to 7)
0	Normal output mode
1	N-ch open-drain output ( $V_{DD}$ tolerance) mode

**(6) Port mode control registers (PMC0, PMC3, PMC10, PMC11, PMC12, PMC14)**

These registers set the P00 to P03, P35 to P37, P100, P115 to P117, P120, and P147 digital I/O/analog input in 1-bit units.

These registers can be set by a 1-bit or 8-bit memory manipulation instruction.

Reset signal generation clears these registers to FFH.

<R>

**Figure 4-70. Format of Port Mode Control Register**

Symbol	7	6	5	4	3	2	1	0	Address	After reset	R/W
PMC0	1	1	1	1	PMC03 Note 2	PMC02 Note 2	PMC01 Note 1	PMC00 Note 1	F0060H	FFH	R/W
PMC3	PMC37 Note 3	PMC36 Note 3	PMC35 Note 3	1	1	1	1	1	F0063H	FFH	R/W
PMC10	1	1	1	1	1	1	1	PMC100 Note 4	F006AH	FFH	R/W
PMC11	PMC117 Note 3	PMC116 Note 3	PMC115 Note 3	1	1	1	1	1	F006BH	FFH	R/W
PMC12	1	1	1	1	1	1	1	PMC120 Note 5	F006CH	FFH	R/W
PMC14	PMC147 Note 6	1	1	1	1	1	1	1	F006EH	FFH	R/W
PMCmn	Pmn pin digital I/O/analog input selection (m = 0, 3, 10 to 12, 14; n = 0 to 3, 5 to 7)										
0	Digital I/O (alternate function other than analog input)										
1	Analog input										

- Notes**
1. 20-, 24-, 25, 30-, 32-pin products only
  2. 52-, 64-, 80-, 100, 128-pin products only
  3. 128-pin products only
  4. 80-, 100-, 128-pin products only
  5. 30-, 32-, 36-, 40-, 44-, 48-, 52-, 64-, 80-, 100, 128-pin products only
  6. All products

**(7) A/D port configuration register (ADPC)**

This register switches the P20/ANI0 to P27/ANI7, and P150/ANI8 to P156/ANI14 pins to digital I/O of port or analog input of A/D converter.

The ADPC register can be set by an 8-bit memory manipulation instruction.

Reset signal generation sets this register to 00H.

**Figure 4-71. Format of A/D Port Configuration Register (ADPC)**

Address: F0076H After reset: 00H R/W

Symbol	7	6	5	4	3	2	1	0
ADPC	0	0	0	0	ADPC3	ADPC2	ADPC1	ADPC0

ADPC3	ADPC2	ADPC1	ADPC0	Analog input (A)/digital I/O (D) switching															
				ANI14/P156	ANI13/P155	ANI12/P154	ANI11/P153	ANI10/P152	ANI9/P151	ANI8/P150	ANI7/P27	ANI6/P26	ANI5/P25	ANI4/P24	ANI3/P23	ANI2/P22	ANI1/P21	ANI0/P20	
0	0	0	0	A	A	A	A	A	A	A	A	A	A	A	A	A	A	A	
0	0	0	1	D	D	D	D	D	D	D	D	D	D	D	D	D	D	D	
0	0	1	0	D	D	D	D	D	D	D	D	D	D	D	D	D	D	A	
0	0	1	1	D	D	D	D	D	D	D	D	D	D	D	D	D	D	A	
0	1	0	0	D	D	D	D	D	D	D	D	D	D	D	D	D	A	A	
0	1	0	1	D	D	D	D	D	D	D	D	D	D	D	A	A	A	A	
0	1	1	0	D	D	D	D	D	D	D	D	D	D	A	A	A	A	A	
0	1	1	1	D	D	D	D	D	D	D	D	D	D	A	A	A	A	A	
1	0	0	0	D	D	D	D	D	D	D	D	A	A	A	A	A	A	A	
1	0	0	1	D	D	D	D	D	D	D	A	A	A	A	A	A	A	A	
1	0	1	0	D	D	D	D	D	D	A	A	A	A	A	A	A	A	A	
1	0	1	1	D	D	D	D	D	A	A	A	A	A	A	A	A	A	A	
1	1	0	0	D	D	D	D	A	A	A	A	A	A	A	A	A	A	A	
1	1	0	1	D	D	D	A	A	A	A	A	A	A	A	A	A	A	A	
1	1	1	0	D	D	A	A	A	A	A	A	A	A	A	A	A	A	A	
1	1	1	1	D	A	A	A	A	A	A	A	A	A	A	A	A	A	A	

- Cautions**
1. Set the channel used for A/D conversion to the input mode by using port mode registers 2, 15 (PM2, PM15).
  2. Do not set the pin set by the ADPC register as digital I/O by the analog input channel specification register (ADS).

**(8) Peripheral I/O redirection register (PIOR)**

This register is used to specify whether to enable or disable the peripheral I/O redirect function.

This function is used to switch ports to which alternate functions are assigned.

The PIOR register can be set by an 8-bit memory manipulation instruction.

Reset signal generation sets this register to 00H.

Figure 4-72. Format of Peripheral I/O Redirection Register (PIOR)

Address: F0077H After reset: 00H R/W

Symbol	7	6	5	4	3	2	1	0
PIOR	0	0	PIOR5	PIOR4	PIOR3	PIOR2	PIOR1	PIOR0

Bit	Function	128/100-pin		80-pin		64-pin		52-pin		48-pin		44-pin		40/36/32/30-pin	
		Setting value		Setting value		Setting value		Setting value		Setting value		Setting value		Setting value	
		0	1	0	1	0	1	0	1	0	1	0	1	0	1
PIOR5	INTP1	P46	P56	This area cannot be used. Be set to 0 (default value).											
	INTP3	P30	P57												
	INTP4	P31	P146												
	INTP6	P140	P84												
	INTP7	P141	P85												
	INTP8	P74	P86												
	INTP9	P75	P87												
	TxD1	P02	P82												
	RxD1	P03	P81												
	SCL10	P04	P80												
	SDA10	P03	P81												
	SI10	P03	P81												
	SO10	P02	P82												
SCK10	P04	P80													
PIOR4	PCLBUZ1	P141	P55	P141	P55	P141	P55								
	INTP5	P16	P12	P16	P12	P16	P12								
PIOR3	PCLBUZ0	P140	P31	P140	P31	P140	P31	P140	P31	P140	P31				
PIOR2	SCLA0	P60	P14	P60	P14	P60	P14	P60	P14	P60	P14	P60	P14	P60	P14
	SDAA0	P61	P13	P61	P13	P61	P13	P61	P13	P61	P13	P61	P13	P61	P13
PIOR1	INTP10	P76	P110	P76	P110	P76	P52	P76	-	-	-	-	-	-	-
	INTP11	P77	P111	P77	P111	P77	P53	P77	-	-	-	-	-	-	-
	TxD2	P13	P77	P13	P77	P13	P77	P13	P77	P13	-	P13	-	P13	-
	RxD2	P14	P76	P14	P76	P14	P76	P14	P76	P14	-	P14	-	P14	-
	SCL20	P15	-	P15	-	P15	-	P15	-	P15	-	P15	-	P15	-
	SDA20	P14	-	P14	-	P14	-	P14	-	P14	-	P14	-	P14	-
	SI20	P14	-	P14	-	P14	-	P14	-	P14	-	P14	-	P14	-
	SO20	P13	-	P13	-	P13	-	P13	-	P13	-	P13	-	P13	-
	SCK20	P15	-	P15	-	P15	-	P15	-	P15	-	P15	-	P15	-
	TxD0	P12	P17	P12	P17	P12	P17	P12	P17	P12	P17	P12	P17	P12	P17
	RxD0	P11	P16	P11	P16	P11	P16	P11	P16	P11	P16	P11	P16	P11	P16
	SCL00	P10	-	P10	-	P10	-	P10	-	P10	-	P10	-	P10	-
SDA00	P11	-	P11	-	P11	-	P11	-	P11	-	P11	-	P11	-	
SI00	P11	P16	P11	P16	P11	P16	P11	-	P11	-	P11	-	P11	-	
SO00	P12	P17	P12	P17	P12	P17	P12	-	P12	-	P12	-	P12	-	
SCK00	P10	P55	P10	P55	P10	P55	P10	-	P10	-	P10	-	P10	-	
PIOR0	TI02/TO02	P17	P15	P17	P15	P17	P15	P17	P15	P17	P15	P17	P15	P17	P15
	TI03/TO03	P31	P14	P31	P14	P31	P14	P31	P14	P31	P14	P31	P14	P31	P14
	TI04/TO04	P42	P13	P42	P13	P42	P13	-	P13	-	P13	-	P13	-	P13
	TI05/TO05	P46	P12	P05	P12	P05	P12	-	P12	-	P12	-	P12	-	P12
	TI06/TO06	P102	P11	P06	P11	P06	P11	-	P11	-	P11	-	P11	-	P11
	TI07/TO07	P145	P10	P41	P10	P41	P10	P41	P10	P41	P10	P41	P10	-	P10

**Cautions 1.** If bit 1 (PIOR1) of the PIOR register is set to 1, the TxD2 and RxD2 pins are redirected, but SCL20, SDA20, SI20, SO20, SCK20 pins are not redirected. Therefore, IIC20 and CSI20 cannot be used in its setting. However, even if the bit is set to 1, CSI21/IIC21 can be used by P70 to P72 if UART2 is not used.

<R>

<R>

**2.** For 20- to 25-pin products, PIOR register is not mounted.

**(9) Global digital input disable register (GDIDIS)**

This register is used to prevent through-current flowing from the input buffers when  $EV_{DD}$  is 0 V.

By setting the GDIDIS0 bit to 1, input to any input buffer connected to  $EV_{DD}$  is prohibited, preventing through-current from flowing when the power supply connected to  $EV_{DD}$  is turned off.

<R> When using the GDIDIS register, be sure to set the GDIDIS0 bit to 1 before turning off the  $EV_{DD}$  power supply, and then clear the GDIDIS0 bit to 0 after turning on the  $EV_{DD}$  power supply.

The GDIDIS register can be set by a 1-bit or 8-bit memory manipulation instruction.

Reset signal generation sets this register to 00H.

**Figure 4-73. Format of Global Digital Input Disable Register (GDIDIS)**

Address: F007DH After reset: 00H R/W

Symbol	7	6	5	4	3	2	1	0
GDIDIS	0	0	0	0	0	0	0	GDIDIS0

GDIDIS0	Setting of input buffers when $EV_{DD}$ is 0 V
0	Input to input buffers permitted (default)
1	Input to input buffers prohibited. No through-current flows to the input buffers.



## 4.4 Port Function Operations

Port operations differ depending on whether the input or output mode is set, as shown below.

### 4.4.1 Writing to I/O port

#### (1) Output mode

A value is written to the output latch by a transfer instruction, and the output latch contents are output from the pin.

Once data is written to the output latch, it is retained until data is written to the output latch again.

The data of the output latch is cleared when a reset signal is generated.

#### (2) Input mode

A value is written to the output latch by a transfer instruction, but since the output buffer is off, the pin status does not change.

Once data is written to the output latch, it is retained until data is written to the output latch again.

The data of the output latch is cleared when a reset signal is generated.

### 4.4.2 Reading from I/O port

#### (1) Output mode

The output latch contents are read by a transfer instruction. The output latch contents do not change.

#### (2) Input mode

The pin status is read by a transfer instruction. The output latch contents do not change.

### 4.4.3 Operations on I/O port

#### (1) Output mode

An operation is performed on the output latch contents, and the result is written to the output latch. The output latch contents are output from the pins.

Once data is written to the output latch, it is retained until data is written to the output latch again.

The data of the output latch is cleared when a reset signal is generated.

#### (2) Input mode

The pin level is read and an operation is performed on its contents. The result of the operation is written to the output latch, but since the output buffer is off, the pin status does not change.

The data of the output latch is cleared when a reset signal is generated.

**<R> 4.4.4 Connecting to external device with different potential (1.8 V, 2.5 V, 3 V)**

When parts of ports 0, 1, 4, 5, and 14 operate with  $V_{DD} = 4.0$  to  $5.5$  V, I/O connections with an external device that operates on 1.8 V, 2.5 V, 3 V power supply voltage are possible.

Regarding inputs, CMOS/TTL switching is possible on a bit-by-bit basis by the port input mode registers (PIM0, PIM1, PIM4, PIM5, PIM8, PIM14).

Moreover, regarding outputs, different potentials can be supported by switching the output buffer to the N-ch open drain ( $V_{DD}$  withstand voltage) by the port output mode registers (POM0, POM1, POM4, POM5, POM8, POM14).

**(1) Setting procedure when using I/O pins of UART0 to UART3, CSI00, CSI01, CSI10, CSI20, CSI30, and CSI31 functions****(a) Use as 1.8 V, 2.5 V, 3 V input port**

<R> <1> If pull-up is needed, externally pull up the pin to be used (on-chip pull-up resistor cannot be used).

In case of UART0:	P11
In case of UART1:	P03 (P81)
In case of UART2:	P14
In case of UART3:	P143
In case of CSI00:	P10, P11
In case of CSI01:	P43, P44
In case of CSI10:	P03, P04 (P80, P81)
In case of CSI20:	P14, P15
In case of CSI30:	P142, P143
In case of CSI31:	P53, P54

<2> After reset release, the port mode is the input mode (Hi-Z).

<3> Set the corresponding bit of the PIM0, PIM1, PIM4, PIM5, PIM8, and PIM14 registers to 1 to switch to the TTL input buffer.

<4>  $V_{IH}/V_{IL}$  operates on 1.8 V, 2.5 V, 3 V operating voltage.

**(b) Use as 1.8 V, 2.5 V, 3 V output port**

<R> <1> Pull up externally the pin to be used (on-chip pull-up resistor cannot be used).

In case of UART0: P12  
 In case of UART1: P02 (P82)  
 In case of UART2: P13  
 In case of UART3: P144  
 In case of CSI00: P10, P12  
 In case of CSI01: P43, P45  
 In case of CSI10: P02, P04 (P80, P82)  
 In case of CSI20: P13, P15  
 In case of CSI30: P142, P144  
 In case of CSI31: P52, P54

<2> After reset release, the port mode changes to the input mode (Hi-Z).

<3> Set the output latch of the corresponding port to 1.

<4> Set the corresponding bit of the POM0, POM1, POM4, POM5, POM8, and POM14 registers to 1 to set the N-ch open drain output ( $V_{DD}$  withstand voltage) mode.

<5> Set the output mode by manipulating the PM0, PM1, PM4, PM5, PM8, and PM14 registers.  
 At this time, the output data is high level, so the pin is in the Hi-Z state.

<6> Can be communication by setting the serial array unit.

**(2) Setting procedure when using I/O pins of IIC00, IIC01, IIC10, IIC20, IIC30, and IIC31 functions**

<R> <1> Externally pull up the pin to be used (on-chip pull-up resistor cannot be used).

In case of IIC00: P10, P11  
 In case of IIC01: P43, P44  
 In case of IIC10: P03, P04  
 In case of IIC20: P14, P15  
 In case of IIC30: P142, P143  
 In case of IIC31: P53, P54

<2> After reset release, the port mode is the input mode (Hi-Z).

<3> Set the output latch of the corresponding port to 1.

<4> Set the corresponding bit of the POM0, POM1, POM4, POM5, and POM14 registers to 1 to set the N-ch open drain output ( $V_{DD}$  withstand voltage) mode.

<5> Set the corresponding bit of the PM0, PM1, PM4, PM5, and PM14 registers to the output mode (data I/O is possible in the output mode).

At this time, the output data is high level, so the pin is in the Hi-Z state.

<6> Enable the operation of the serial array unit and set the mode to the simplified I<sup>2</sup>C mode.

#### 4.5 Settings of Port Mode Register, and Output Latch When Using Alternate Function

To use the alternate function of a port pin, set the port mode register, and output latch as shown in Table 4-23.

<R> **Table 4-23. Settings of Port Mode Register, and Output Latch When Using Alternate Function (1/5)**

Pin Name	Alternate Function		PIOR <sub>x</sub>	POM <sub>xx</sub>	PMC <sub>xx</sub>	PM <sub>xx</sub>	P <sub>xx</sub>
	Function Name	I/O					
P00	TI00	Input	×	×	–	1	×
P01	TO00	Output	×	–	–	0	0
P02	ANI17 <sup>Note 1</sup>	Input	×	×	1	1	×
	SO10	Output	0	0/1	0	0	1
	TxD1	Output	0	0/1	0	0	1
P03	ANI16 <sup>Note 1</sup>	Input	×	×	1	1	×
	SI10	Input	0	×	0	1	×
	RxD1	Input	0	×	0	1	×
	SDA10	I/O	0	1	0	0	1
P04	SCK10	Input	0	×	–	1	×
		Output	0	0/1	–	0	1
	SCL10	Output	0	0/1	–	0	1
P10	SCK00	Input	0	×	–	1	×
		Output	0	0/1	–	0	1
	SCL00	Output	0	0/1	–	0	1
	(TI07)	Input	1	×	–	1	×
	(TO07)	Output	1	0/1	–	0	0
P11	SI00	Input	0	×	–	1	×
	RxD0	Input	0	×	–	1	×
	TOOLRxD	Input	×	×	–	1	×
	SDA00	I/O	0	1	–	0	1
	(TI06)	Input	1	×	–	1	×
	(TO06)	Output	1	0/1	–	0	0
P12	SO00	Output	0	0/1	–	0	1
	TxD0	Output	0	0/1	–	0	1
	TOOLTxD	Output	×	0/1	–	0	1
	(INTP5)	Input	1	×	–	1	×
	(TI05)	Input	1	×	–	1	×
	(TO05)	Output	1	0/1	–	0	0

**Remarks 1.** ×: don't care

PIOR<sub>x</sub>: Peripheral I/O redirection register

POM<sub>xx</sub>: Port output mode register

PMC<sub>xx</sub>: Port mode control register

PM<sub>xx</sub>: Port mode register

P<sub>xx</sub>: Port output latch

**2.** The relationship between pins and their alternate functions shown in this table indicates the relationship when a 128-pin product is used. In other products, alternate functions might be assigned to different pins, but even in this case, the PIOR<sub>x</sub>, POM<sub>xx</sub>, PMC<sub>xx</sub>, PM<sub>xx</sub>, and P<sub>xx</sub> set in the same way.

**3.** Functions in parentheses in the above table can be assigned via settings in the peripheral I/O redirection register (PIOR).

(The **Note 1** is described after the last table.)

<R> **Table 4-23. Settings of Port Mode Register, and Output Latch When Using Alternate Function (2/5)**

Pin Name	Alternate Function		PIOR <sub>x</sub>	POM <sub>xx</sub>	PMC <sub>xx</sub>	PM <sub>xx</sub>	P <sub>xx</sub>
	Function Name	I/O					
P13	TxD2	Output	0	0/1	–	0	1
	SO20	Output	0	0/1	–	0	1
	(SDAA0)	I/O	1	1	–	0	0
	(TI04)	Input	1	×	–	1	×
	(TO04)	Output	1	0/1	–	0	0
P14	RxD2	Input	0	×	–	1	×
	SI20	Input	0	×	–	1	×
	SDA20	I/O	0	1	–	0	1
	(SCLA0)	I/O	1	1	–	0	0
	(TI03)	Input	1	×	–	1	×
	(TO03)	Output	1	0/1	–	0	0
P15 <sup>Note 3</sup>	SCK20	Input	0	×	–	1	×
		Output	0	0/1	–	0	1
	SCL20	Output	0	0/1	–	0	1
	(TI02)	Input	1	×	–	1	×
	(TO02)	Output	1	0/1	–	0	0
P16 <sup>Note 3</sup>	TI01	Input	×	–	–	1	×
	TO01	Output	×	–	–	0	0
	INTP5	Input	0	–	–	1	×
	(SI00)	Input	1	–	–	1	×
	(RxD0)	Input	1	–	–	1	×
P17 <sup>Note 3</sup>	TI02	Input	0	×	–	1	×
	TO02	Output	0	0/1	–	0	0
	(SO00)	Output	1	0/1	–	0	1
	(TxD0)	Output	1	0/1	–	0	1
P20 <sup>Note 2</sup>	ANIO <sup>Note 2</sup>	Input	×	–	–	1	×
	AV <sub>REFP</sub> <sup>Note 2</sup>	Input	×	–	–	1	×
P21 <sup>Note 2</sup>	ANI1 <sup>Note 2</sup>	Input	×	–	–	1	×
	AV <sub>REFM</sub> <sup>Note 2</sup>	Input	×	–	–	1	×
P22 to P27 <sup>Note 2</sup>	ANI2 to ANI7 <sup>Note 2</sup>	Input	×	–	–	1	×

- Remarks 1.** ×: don't care  
 PIOR<sub>x</sub>: Peripheral I/O redirection register  
 POM<sub>xx</sub>: Port output mode register  
 PMC<sub>xx</sub>: Port mode control register  
 PM<sub>xx</sub>: Port mode register  
 P<sub>xx</sub>: Port output latch
- 2.** The relationship between pins and their alternate functions shown in this table indicates the relationship when a 128-pin product is used. In other products, alternate functions might be assigned to different pins, but even in this case, the PIOR<sub>x</sub>, POM<sub>xx</sub>, PMC<sub>xx</sub>, PM<sub>xx</sub>, and P<sub>xx</sub> set in the same way.
- 3.** Functions in parentheses in the above table can be assigned via settings in the peripheral I/O redirection register (PIOR).

(The **Notes 2** and **3** are described after the last table.)

<R> **Table 4-23. Settings of Port Mode Register, and Output Latch When Using Alternate Function (3/5)**

Pin Name	Alternate Function		PIOR <sub>x</sub>	POM <sub>xx</sub>	PMC <sub>xx</sub>	PM <sub>xx</sub>	P <sub>xx</sub>
	Function Name	I/O					
P30 <sup>Note 3</sup>	INTP3	Input	0	–	–	1	×
	RTC1HZ	Output	×	–	–	0	0
P31 <sup>Note 3</sup>	TI03	Input	0	–	–	1	×
	TO03	Output	0	–	–	0	0
	INTP4	Input	0	–	–	1	×
	(PCLBUZ0)	Output	1	–	–	0	0
P35 to P37 <sup>Note 1</sup>	ANI23 to AN21 <sup>Note 1</sup>	Input	×	–	1	1	×
P40	TOOL0	I/O	×	–	–	×	×
P42	TI04	Input	0	–	–	1	×
	TO04	Output	0	–	–	0	0
P43	SCK01	Input	×	×	–	1	×
		Output	×	0/1	–	0	1
	SCL01	Output	×	0/1	–	0	1
P44	SI01	Input	×	×	–	1	×
	SDA01	I/O	×	1	–	0	1
P45	SO01	Output	×	0/1	–	0	1
P46	INTP1	Input	0	–	–	1	×
	TI05	Input	0	–	–	1	×
	TO05	Output	0	–	–	0	0
P47	INTP2	Input	×	–	–	1	×
P52	SO31	Output	×	0/1	–	0	1
P53	SI31	Input	×	×	–	1	×
	SDA31	I/O	×	1	–	0	1
P54	SCK31	Input	×	×	–	1	×
		Output	×	0/1	–	0	1
	SCL31	Output	×	0/1	–	0	1
P55	(PCLBUZ1)	Output	1	0/1	–	0	0
	(SCK00)	Input	1	×	–	1	×
		Output	1	0/1	–	0	1
P56	(INTP1)	Input	1	–	–	1	×
P57	(INTP3)	Input	1	–	–	1	×

**Remarks 1.** ×: don't care

PIOR<sub>x</sub>: Peripheral I/O redirection register

POM<sub>xx</sub>: Port output mode register

PMC<sub>xx</sub>: Port mode control register

PM<sub>xx</sub>: Port mode register

P<sub>xx</sub>: Port output latch

- The relationship between pins and their alternate functions shown in this table indicates the relationship when a 128-pin product is used. In other products, alternate functions might be assigned to different pins, but even in this case, the PIOR<sub>x</sub>, POM<sub>xx</sub>, PMC<sub>xx</sub>, PM<sub>xx</sub>, and P<sub>xx</sub> set in the same way.
- Functions in parentheses in the above table can be assigned via settings in the peripheral I/O redirection register (PIOR).

(The **Notes 1, 3** are described after the last table.)

<R> **Table 4-23. Settings of Port Mode Register, and Output Latch When Using Alternate Function (4/5)**

Pin Name	Alternate Function		PIOR <sub>x</sub>	POM <sub>xx</sub>	PMC <sub>xx</sub>	PM <sub>xx</sub>	P <sub>xx</sub>
	Function Name	I/O					
P60	SCLA0	I/O	0	–	–	0	0
P61	SDAA0	I/O	0	–	–	0	0
P62	SCLA1	I/O	×	–	–	0	0
P63	SDAA1	I/O	×	–	–	0	0
P64 to P67	TI10 to TI13	Input	×	–	–	1	×
	TO10 to TO13	Output	×	–	–	0	0
P70	KR0	Input	×	–	–	1	×
	SCK21	Input	×	–	–	1	×
		Output	×	–	–	0	1
	SCL21	Output	×	–	–	0	1
P71	KR1	Input	×	×	–	1	×
	SI21	Input	×	×	–	1	×
	SDA21	I/O	×	1	–	0	1
P72	KR2	Input	×	–	–	1	×
	SO21	Output	×	–	–	0	1
P73	KR3	Input	×	–	–	1	×
P74, P75	KR4, KR5	Input	×	×	–	1	×
	INTP8, INTP9	Input	0	×	–	1	×
P76	KR6	Input	×	×	–	1	×
	INTP10	Input	0	×	–	1	×
	(RxD2)	Input	1	×	–	1	×
P77	KR7	Input	×	–	–	1	×
	INTP11	Input	0	–	–	1	×
	(TxD2)	Output	1	0/1	–	0	1
P80	(SCK10)	Input	1	×	–	1	×
		Output	1	0/1	–	0	1
	(SCL10)	Output	1	0/1	–	0	1
P81	(SI10)	Input	1	×	–	1	×
	(RxD1)	Input	1	×	–	1	×
	(SDA10)	I/O	1	1	–	0	1
P82	(SO10)	Output	1	0/1	–	0	1
	(TxD1)	Output	1	0/1	–	0	1
P84 to P87	(INTP6) to (INTP9)	Input	1	–	–	1	×

**Remarks 1.** ×: don't care

PIOR<sub>x</sub>: Peripheral I/O redirection register

POM<sub>xx</sub>: Port output mode register

PMC<sub>xx</sub>: Port mode control register

PM<sub>xx</sub>: Port mode register

P<sub>xx</sub>: Port output latch

- The relationship between pins and their alternate functions shown in this table indicates the relationship when a 128-pin product is used. In other products, alternate functions might be assigned to different pins, but even in this case, the PIOR<sub>x</sub>, POM<sub>xx</sub>, PMC<sub>xx</sub>, PM<sub>xx</sub>, and P<sub>xx</sub> set in the same way.
- Functions in parentheses in the above table can be assigned via settings in the peripheral I/O redirection register (PIOR).

<R> **Table 4-23. Settings of Port Mode Register, and Output Latch When Using Alternate Function (5/5)**

Pin Name	Alternate Function		PIOR <sub>x</sub>	POM <sub>xx</sub>	PMC <sub>xx</sub>	PM <sub>xx</sub>	P <sub>xx</sub>
	Function Name	I/O					
P95	SCK11	Input	×	–	–	1	×
		Output	×	–	–	0	1
	SCL11	Output	×	–	–	0	1
P96	SI11	Input	×	×	–	1	×
	SDA11	I/O	×	1	–	0	1
P97	SO11	Output	×	–	–	0	1
P100	ANI20 <sup>Note 1</sup>	Input	×	–	1	1	×
P102	TI06	Input	0	–	–	1	×
	TO06	Output	0	–	–	0	0
P103 to P106	TI14 to TI17	Input	×	–	–	1	×
	TO14 to TO17	Output	×	–	–	0	0
P110, P111	(INTP10), (INTP11)	Input	1	–	–	1	×
P115 to P117	ANI26 to ANI24 <sup>Note 1</sup>	Input	×	–	1	1	×
P120	ANI19 <sup>Note 1</sup>	Input	×	–	1	1	×
P137	INTP0	Input	×	–	–	–	×
P140	PCLBUZ0	Output	0	–	–	0	0
	INTP6	Input	0	–	–	1	×
P141	PCLBUZ1	Output	0	–	–	0	0
	INTP7	Input	0	–	–	1	×
P142	SCK30	Input	×	×	–	1	×
		Output	×	0/1	–	0	1
	SCL30	Output	×	0/1	–	0	1
P143	RxD3	Input	×	×	–	1	×
	SI30	Input	×	×	–	1	×
	SDA30	I/O	×	1	–	0	1
P144	TxD3	Output	×	0/1	–	0	1
	SO30	Output	×	0/1	–	0	1
P145	TI07	Input	0	–	–	1	×
	TO07	Output	0	–	–	0	0
P146	(INTP4)	Input	1	–	–	1	×
P147	ANI18 <sup>Note 1</sup>	Input	×	–	1	1	×
P150 to P156 <sup>Note 2</sup>	ANI8 to ANI14 <sup>Note 2</sup>	Input	×	–	–	1	×

**Remarks 1.** ×: don't care

PIOR<sub>x</sub>: Peripheral I/O redirection register

POM<sub>xx</sub>: Port output mode register

PMC<sub>xx</sub>: Port mode control register

PM<sub>xx</sub>: Port mode register

P<sub>xx</sub>: Port output latch

- The relationship between pins and their alternate functions shown in this table indicates the relationship when a 128-pin product is used. In other products, alternate functions might be assigned to different pins, but even in this case, the PIOR<sub>x</sub>, POM<sub>xx</sub>, PMC<sub>xx</sub>, PM<sub>xx</sub>, and P<sub>xx</sub> set in the same way.
- Functions in parentheses in the above table can be assigned via settings in the peripheral I/O redirection register (PIOR).



**Notes** 1. The functions of the ANI16/P03, ANI17/P02, ANI18/P147, ANI19/P120, ANI20/P100, ANI21/P37 to ANI23/P35, and ANI24/P117 to ANI26/P115 pins can be selected by using the port mode control registers 0, 3, 10, 11, 12, 14 (PMC0, PMC3, PMC10, PMC11, PMC12, PMC14), analog input channel specification register (ADS), and port mode registers 0, 3, 10, 11, 12, 14 (PM0, PM3, PM10, PM11, PM12, PM14).

**Table 4-24. Setting Functions of ANI16/P03, ANI17/P02, ANI18/P147, ANI19/P120, ANI20/P100, ANI21/P37 to ANI23/P35, and ANI24/P117 to ANI26/P115 pins**

PMC0, PMC3, PMC10, PMC11, PMC12, PMC14 Registers	PM0, PM3, PM10, PM11, PM12, PM14 Registers	ADS Register	ANI16/P03, ANI17/P02, ANI18/P147, ANI19/P120, ANI20/P100, ANI21/P37 to ANI23/P35, ANI24/P117 to ANI26/P115 Pins
Digital I/O selection	Input mode	×	Digital input
	Output mode	×	Digital output
Analog input selection	Input mode	Selects ANI.	Analog input (to be converted)
		Does not select ANI.	Analog input (not to be converted)
	Output mode	Selects ANI.	Setting prohibited
		Does not select ANI.	

2. The functions of the ANI0/P20 to ANI7/P27, ANI8/P150 to ANI14/P156 pins can be selected by using the A/D port configuration register (ADPC), analog input channel specification register (ADS), and port mode registers 2, 15 (PM2, PM15).

**Table 4-25. Setting Functions of ANI0/P20 to ANI7/P27, ANI8/P150 to ANI14/P156 pins**

ADPC Register	PM2, PM5 Register	ADS Register	ANI0/P20 to ANI7/P27, ANI8/P150 to ANI14/P156 Pins
Digital I/O selection	Input mode	×	Digital input
	Output mode	×	Digital output
Analog input selection	Input mode	Selects ANI.	Analog input (to be converted)
		Does not select ANI.	Analog input (not to be converted)
	Output mode	Selects ANI.	Setting prohibited
		Does not select ANI.	

<R>

3. In the products other than 128-pin products, multiple alternate output functions are assigned to the pins. In such cases, the output from the alternate functions that are not used in any settings except the one indicated in **table 4-23** must be set to the same value as the one in the initial status. For more detail about the targets and the method of processing, refer to the section **4.6.2**.

**Remark** ×: don't care

<R> 4.6 Cautions When Using Port Function

4.6.1 Cautions on 1-Bit Manipulation Instruction for Port Register n (Pn)

When a 1-bit manipulation instruction is executed on a port that provides both input and output functions, the output latch value of an input port that is not subject to manipulation may be written in addition to the targeted bit.

Therefore, it is recommended to rewrite the output latch when switching a port from input mode to output mode.

<Example> When P10 is an output port, P11 to P17 are input ports (all pin statuses are high level), and the port latch value of port 1 is 00H, if the output of output port P10 is changed from low level to high level via a 1-bit manipulation instruction, the output latch value of port 1 is FFH.

Explanation: The targets of writing to and reading from the Pn register of a port whose PMnm bit is 1 are the output latch and pin status, respectively.

A 1-bit manipulation instruction is executed in the following order in the RL78/G13.

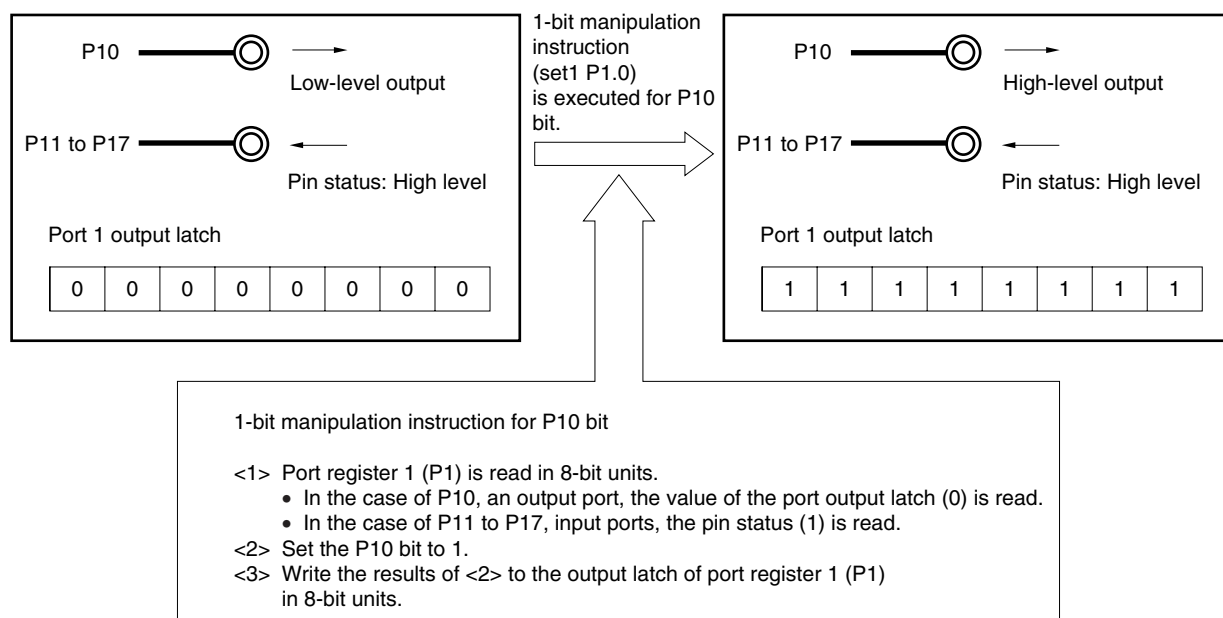
- <1> The Pn register is read in 8-bit units.
- <2> The targeted one bit is manipulated.
- <3> The Pn register is written in 8-bit units.

In step <1>, the output latch value (0) of P10, which is an output port, is read, while the pin statuses of P11 to P17, which are input ports, are read. If the pin statuses of P11 to P17 are high level at this time, the read value is FEH.

The value is changed to FFH by the manipulation in <2>.

FFH is written to the output latch by the manipulation in <3>.

Figure 4-74. Bit Manipulation Instruction (P10)



**<R> 4.6.2 Cautions on the pin settings on the products other than 128-pin**

In the products other than 128-pin products, multiple alternate output functions may be assigned to P15 to P17, P30 and P31 pins.

In such cases, the output from the alternate functions that are not used in any settings except the one indicated in Table 4-23 must be set to the same value as the one in the initial status.

The following indicates the specific targets and the method of processing;

**(1) 30- to 52-pin products: P15/PCLBUZ1/ $\overline{\text{SCK20}}$ /SCL20/(TI02)/(TO02)**

- Using PCLBUZ1:  $\overline{\text{SCK20}}$ /SCL20 output set to 1  
Set serial channel enable status register 1 (SE1), serial output register 1 (SO1) and serial output enable register 1 (SOE1) to the default status.
- Using  $\overline{\text{SCK20}}$ /SCL20: PCLBUZ1 output clear to 0  
Set bit 7 (PCLOE1) of clock output select register 1 (CKS1) to "0", which is the same as their default status setting.

**(2) 20-pin products: P16/TI01/TO01/INTP5/SO11**

- Using TO01: SO11 output set to 1  
Set serial channel enable status register 0 (SE0), serial output register 0 (SO0) and serial output enable register 0 (SOE0) to the default status.
- Using SO11: TO01 output clear to 0  
Set bit 1 (TO01) of timer output register 0 (TO0) and bit 1 (TOE01) of timer output enable register 0 (TOE0) to "0", which is the same as their default status setting.

**(3) 20-pin products: P17/TI02/TO02/SI11/SDA11**

- Using TO02: SDA11 output set to 1  
Set serial channel enable status register 0 (SE0), serial output register 0 (SO0) and serial output enable register 0 (SOE0) to the default status.
- Using SDA11: TO02 output clear to 0  
Set bit 2 (TO02) of timer output register 0 (TO0) and bit 2 (TOE02) of timer output enable register 0 (TOE0) to "0", which is the same as their default status setting.

**(4) 24- and 25-pin products: P17/TI02/TO02/SO11**

- Using TO02: SO11 output set to 1  
Set serial channel enable status register 0 (SE0), serial output register 0 (SO0) and serial output enable register 0 (SOE0) to the default status.
- Using SO11: TO02 output clear to 0  
Set bit 2 (TO02) of timer output register 0 (TO0) and bit 2 (TOE02) of timer output enable register 0 (TOE0) to "0", which is the same as their default status setting.

**(5) 40- to 100-pin products: P30/INTP3/RTC1HZ/ $\overline{\text{SCK11}}$ /SCL11**

- Using RTC1HZ:  $\overline{\text{SCK11}}$ /SCL11 output set to 1  
Set serial channel enable status register 0 (SE0), serial output register 0 (SO0) and serial output enable register 0 (SOE0) to the default status.
- Using  $\overline{\text{SCK11}}$ /SCL11: RTC1HZ output clear to 0  
Set bit 5 (RCLOE1) of real-time clock control register 0 (RTCC0) to "0", which is the same as its default status setting.

**(6) 24- to 44-pin products: P31/TI03/TO03/INTP4/PCLBUZ0**

- Using TO03: PCLBUZ0 output clear to 0
  - Set bit 7 (PCLOE0) of clock output select register 0 (CKS0) to “0”, which is the same as their default status setting.
- Using PCLBUZ0: TO03 output clear to 0
  - Set bit 3 (TO03) of timer output register 0 (TO0) and bit 3 (TOE03) of timer output enable register 0 (TOE0) to “0”, which is the same as their default status setting.

## CHAPTER 5 CLOCK GENERATOR

The presence or absence of connecting resonator pin for main system clock, connecting resonator pin for subsystem clock, external clock input pin for main system clock, and external clock input pin for subsystem clock, depends on the product.

Output pin	20, 24, 25, 30, 32, 36-pin	40, 44, 48, 52, 64, 80, 100, 128-pin
X1, X2 pins	√	√
EXCLK pin	√	√
XT1, XT2 pins	–	√
EXCLKS pin	–	√

**Note** The 20, 24, 25, 30, 32, and 36-pin products don't have the subsystem clock.

### 5.1 Functions of Clock Generator

The clock generator generates the clock to be supplied to the CPU and peripheral hardware.

The following three kinds of system clocks and clock oscillators are selectable.

#### (1) Main system clock

##### <1> X1 oscillator

This circuit oscillates a clock of  $f_x = 1$  to 20 MHz by connecting a resonator to X1 and X2.

Oscillation can be stopped by executing the STOP instruction or setting of the MSTOP bit (bit 7 of the clock operation status control register (CSC)).

##### <2> High-speed on-chip oscillator (High-speed OCO)

The frequency at which to oscillate can be selected from among  $f_{IH} = 32, 24, 16, 12, 8, 4,$  or 1 MHz (typ.) by using the option byte (000C2H). After a reset release, the CPU always starts operating with this high-speed on-chip oscillator clock. Oscillation can be stopped by executing the STOP instruction or setting the HIOSTOP bit (bit 0 of the CSC register).

An external main system clock ( $f_{EX} = 1$  to 20 MHz) can also be supplied from the EXCLK/X2/P122 pin. An external main system clock input can be disabled by executing the STOP instruction or setting of the MSTOP bit.

As the main system clock, a high-speed system clock (X1 clock or external main system clock) or high-speed on-chip oscillator clock can be selected by setting of the MCM0 bit (bit 4 of the system clock control register (CKC)).

**(2) Subsystem clock**

- **XT1 clock oscillator**

This circuit oscillates a clock of  $f_{XT} = 32.768$  kHz by connecting a 32.768 kHz resonator to XT1 and XT2. Oscillation can be stopped by setting the XTSTOP bit (bit 6 of the clock operation status control register (CSC)).

<R> An external subsystem clock ( $f_{EXS} = 32.768$  KHz) can also be supplied from the EXCLKS/XT2/P124 pin. An external subsystem clock input can be disabled by the setting of the XTSTOP bit.

**(3) Low-speed on-chip oscillator clock (Low-speed OCO)**

This circuit oscillates a clock of  $f_{IL} = 15$  kHz (TYP.).

The low-speed on-chip oscillator clock cannot be used as the CPU clock.

Only the following peripheral hardware runs on the low-speed on-chip oscillator clock.

- Watchdog timer
- Real-time clock
- Interval timer

This clock operates when bit 4 (WDTON) of the option byte (000C0H), bit 4 (WUTMMCK0) of the operation speed mode control register (OSMC), or both are set to 1.

However, when WDTON = 1, WUTMMCK0 = 0, and bit 0 (WDSTBYON) of the option byte (000C0H) is 0, oscillation of the low-speed on-chip oscillator stops if the HALT or STOP instruction is executed.

**Caution** The low-speed on-chip oscillator clock ( $f_{IL}$ ) can only be selected as the real-time clock operation clock when the fixed-cycle interrupt function is used.

**Remark**

- fx: X1 clock oscillation frequency
- $f_{IH}$ : High-speed on-chip oscillator clock frequency
- $f_{EX}$ : External main system clock frequency
- $f_{XT}$ : XT1 clock oscillation frequency
- $f_{EXS}$ : External subsystem clock frequency
- $f_{IL}$ : Low-speed on-chip oscillator clock frequency

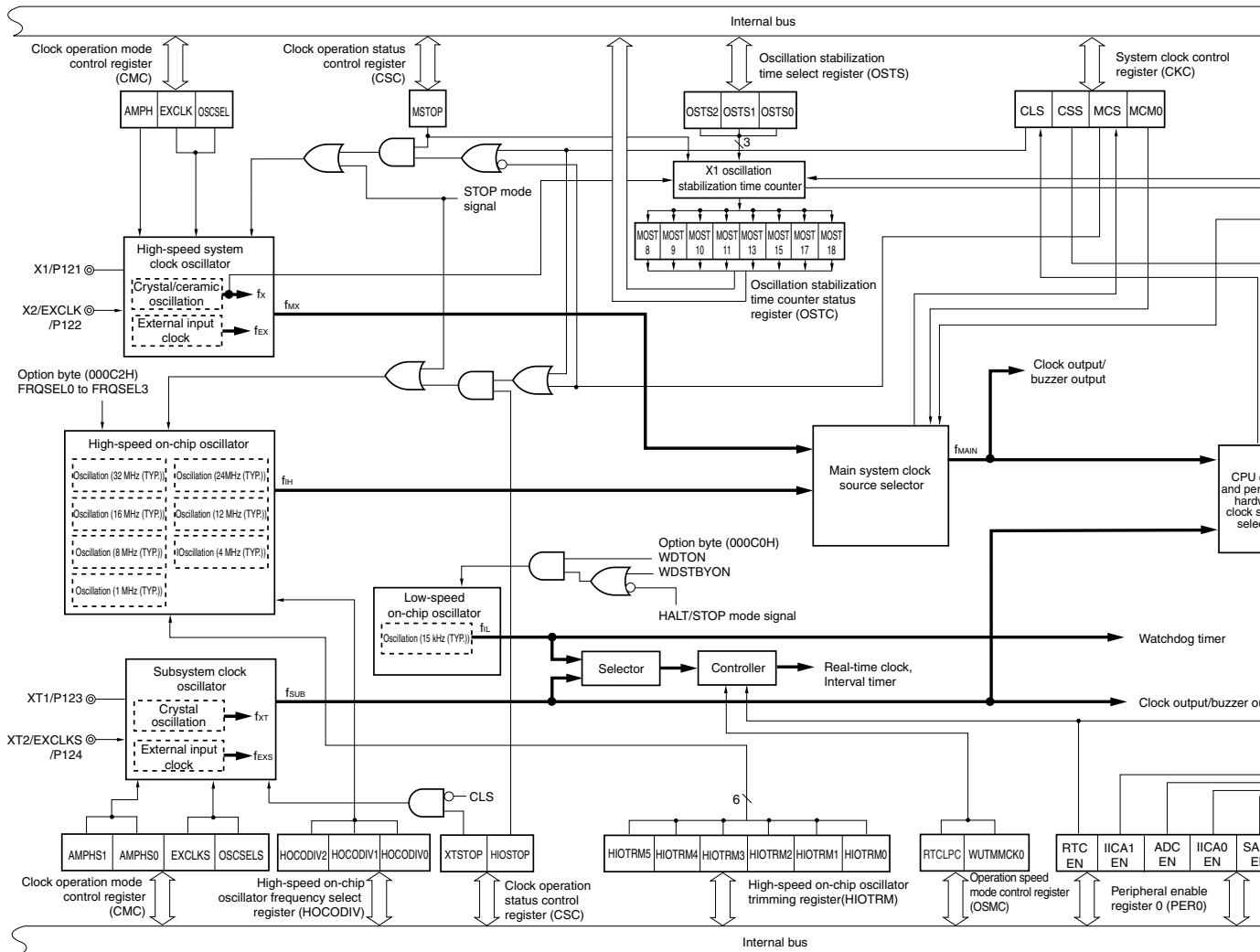
## 5.2 Configuration of Clock Generator

The clock generator includes the following hardware.

**Table 5-1. Configuration of Clock Generator**

Item	Configuration
Control registers	Clock operation mode control register (CMC) System clock control register (CKC) Clock operation status control register (CSC) Oscillation stabilization time counter status register (OSTC) Oscillation stabilization time select register (OSTS) Peripheral enable register 0 (PER0) Operation speed mode control register (OSMC) High-speed on-chip oscillator frequency select register (HOCODIV) High-speed on-chip oscillator trimming register (HIOTRM)
Oscillators	X1 oscillator XT1 oscillator High-speed on-chip oscillator Low-speed on-chip oscillator

Figure 5-1. Block Diagram of Clock Generator



(Remark is listed on the next page after next.)



<b>Remark</b>	<b>fx:</b>	X1 clock oscillation frequency
	<b>f<sub>IH</sub>:</b>	High-speed on-chip oscillator clock frequency
	<b>f<sub>EX</sub>:</b>	External main system clock frequency
	<b>f<sub>MX</sub>:</b>	High-speed system clock frequency
	<b>f<sub>MAIN</sub>:</b>	Main system clock frequency
	<b>f<sub>XT</sub>:</b>	XT1 clock oscillation frequency
	<b>f<sub>EXS</sub>:</b>	External subsystem clock frequency
	<b>f<sub>SUB</sub>:</b>	Subsystem clock frequency
	<b>f<sub>CLK</sub>:</b>	CPU/peripheral hardware clock frequency
	<b>f<sub>IL</sub>:</b>	Low-speed on-chip oscillator clock frequency

### 5.3 Registers Controlling Clock Generator

The following nine registers are used to control the clock generator.

- Clock operation mode control register (CMC)
- System clock control register (CKC)
- Clock operation status control register (CSC)
- Oscillation stabilization time counter status register (OSTC)
- Oscillation stabilization time select register (OSTS)
- Peripheral enable register 0 (PER0)
- Operation speed mode control register (OSMC)
- High-speed on-chip oscillator frequency select register (HOCODIV)
- High-speed on-chip oscillator trimming register (HIOTRM)

#### (1) Clock operation mode control register (CMC)

This register is used to set the operation mode of the X1/P121, X2/EXCLK/P122, XT1/P123, and XT2/EXCLKS/P124 pins, and to select a gain of the oscillator.

The CMC register can be written only once by an 8-bit memory manipulation instruction after reset release. This register can be read by an 8-bit memory manipulation instruction.

Reset signal generation clears this register to 00H.

**Figure 5-2. Format of Clock Operation Mode Control Register (CMC)**

Address: FFFA0H After reset: 00H R/W

Symbol	7	6	5	4	3	2	1	0
CMC	EXCLK	OSCSEL	EXCLKS	OSCSELS	0	AMPHS1	AMPHS0	AMPH
	EXCLK	OSCSEL	High-speed system clock pin operation mode		X1/P121 pin		X2/EXCLK/P122 pin	
	0	0	Input port mode		Input port			
	0	1	X1 oscillation mode		Crystal/ceramic resonator connection			
	1	0	Input port mode		Input port			
	1	1	External clock input mode		Input port		External clock input	
	EXCLKS	OSCSELS	Subsystem clock pin operation mode		XT1/P123 pin		XT2/EXCLKS/P124 pin	
	0	0	Input port mode		Input port			
	0	1	XT1 oscillation mode		Crystal resonator connection			
	1	0	Input port mode		Input port			
	1	1	External clock input mode		Input port		External clock input	
	AMPHS1	AMPHS0	XT1 oscillator oscillation mode selection <sup>Note</sup>					
	0	0	Low power consumption oscillation (default)			Oscillation margin: Medium		
	0	1	Normal oscillation			Oscillation margin: high		
	1	0	Ultra-low power consumption oscillation			Oscillation margin: Low		
	1	1	Setting prohibited					
	AMPH	Control of X1 clock oscillation frequency						
	0	1 MHz ≤ f <sub>x</sub> ≤ 10 MHz						
	1	10 MHz < f <sub>x</sub> ≤ 20 MHz						

<R>

<R>

**Note** As the XT oscillator becomes oscillation mode with lower power consumption, then its oscillation margin becomes smaller.

- Cautions**
1. The CMC register can be written only once after reset release, by an 8-bit memory manipulation instruction.
  2. After reset release, set the CMC register before X1 or XT1 oscillation is started as set by the clock operation status control register (CSC).
  3. Be sure to set the AMPH bit to 1 if the X1 clock oscillation frequency exceeds 10 MHz.
  4. When the CMC register is used at the default value (00H), be sure to set 00H to this register after reset release in order to prevent malfunctioning during a program loop.
  5. The XT1 oscillator is a circuit with low amplification in order to achieve low-power consumption. Note the following points when designing the circuit.
    - Pins and circuit boards include parasitic capacitance. Therefore, perform oscillation evaluation using a circuit board to be actually used and confirm that there are no problems.
    - When using the ultra-low power consumption oscillation (AMPHS1, AMPHS0 = 1, 0) as the mode of the XT1 oscillator, use the recommended resonators described in CHAPTER 29 ELECTRICAL SPECIFICATIONS.

(Cautions and Remark are given on the next page.)

- Make the wiring between the XT1 and XT2 pins and the resonators as short as possible, and minimize the parasitic capacitance and wiring resistance. Note this particularly when the ultra-low power consumption oscillation (AMPHS1, AMPHS0 = 1, 0) is selected.
- Configure the circuit of the circuit board, using material with little wiring resistance.
- Place a ground pattern that has the same potential as  $V_{SS}$  as much as possible near the XT1 oscillator.
- Be sure that the signal lines between the XT1 and XT2 pins, and the resonators do not cross with the other signal lines. Do not route the wiring near a signal line through which a high fluctuating current flows.
- The impedance between the XT1 and XT2 pins may drop and oscillation may be disturbed due to moisture absorption of the circuit board in a high-humidity environment or dew condensation on the board. When using the circuit board in such an environment, take measures to damp-proof the circuit board, such as by coating.
- When coating the circuit board, use material that does not cause capacitance or leakage between the XT1 and XT2 pins.

**Remark** fx: X1 clock frequency

**(2) System clock control register (CKC)**

<R> This register is used to select a CPU/peripheral hardware clock and a main system clock. The CKC register can be set by a 1-bit or 8-bit memory manipulation instruction. Reset signal generation sets this register to 00H.

**Figure 5-3. Format of System Clock Control Register (CKC)**

Address: FFFA4H After reset: 00H R/W<sup>Note 1</sup>

Symbol	<7>	<6>	<5>	<4>	3	2	1	0
CKC	CLS	CSS	MCS	MCM0	0	0	0	0

CLS	Status of CPU/peripheral hardware clock (f <sub>CLK</sub> )
0	Main system clock (f <sub>MAIN</sub> )
1	Subsystem clock (f <sub>SUB</sub> )

CSS	Selection of CPU/peripheral hardware clock (f <sub>CLK</sub> )
0	Main system clock (f <sub>MAIN</sub> )
1 <sup>Note 2</sup>	Subsystem clock (f <sub>SUB</sub> )

MCS	Status of Main system clock (f <sub>MAIN</sub> )
0	High-speed on-chip oscillator clock (f <sub>IH</sub> )
1	High-speed system clock (f <sub>MX</sub> )

MCM0 <sup>Note 2</sup>	Main system clock (f <sub>MAIN</sub> ) operation control
0	Selects the high-speed on-chip oscillator clock (f <sub>IH</sub> ) as the main system clock (f <sub>MAIN</sub> )
1	Selects the high-speed system clock (f <sub>MX</sub> ) as the main system clock (f <sub>MAIN</sub> )

- Notes 1.** Bits 7 and 5 are read-only.  
**2.** Changing the value of the MCM0 bit is prohibited while the CSS bit is set to 1.

**Remark** f<sub>IH</sub>: High-speed on-chip oscillator clock frequency  
 f<sub>MX</sub>: High-speed system clock frequency  
 f<sub>MAIN</sub>: Main system clock frequency  
 f<sub>SUB</sub>: Subsystem clock frequency

(Caution is listed on the next page.)

- Cautions**
1. Be sure to set bit 3 to 0 to 0.
  2. The clock set by the CSS bit is supplied to the CPU and peripheral hardware. If the CPU clock is changed, therefore, the clock supplied to peripheral hardware (except the real-time clock, interval timer, clock output/buzzer output, and watchdog timer) is also changed at the same time. Consequently, stop each peripheral function when changing the CPU/peripheral hardware clock.
  3. If the subsystem clock is used as the peripheral hardware clock, the operations of the A/D converter and IICA are not guaranteed. For the operating characteristics of the peripheral hardware, refer to the chapters describing the various peripheral hardware as well as CHAPTER 29 ELECTRICAL SPECIFICATIONS.

**(3) Clock operation status control register (CSC)**

This register is used to control the operations of the high-speed system clock, high-speed on-chip oscillator clock, and subsystem clock (except the low-speed on-chip oscillator clock).

The CSC register can be set by a 1-bit or 8-bit memory manipulation instruction.

Reset signal generation sets this register to C0H.

**Figure 5-4. Format of Clock Operation Status Control Register (CSC)**

Address: FFFA1H After reset: C0H R/W

Symbol	<7>	<6>	5	4	3	2	1	<0>
CSC	MSTOP	XTSTOP	0	0	0	0	0	HIOSTOP

MSTOP	High-speed system clock operation control		
	X1 oscillation mode	External clock input mode	Input port mode
0	X1 oscillator operating	External clock from EXCLK pin is valid	Input port
1	X1 oscillator stopped	External clock from EXCLK pin is invalid	

XTSTOP	Subsystem clock operation control		
	XT1 oscillation mode	External clock input mode	Input port mode
0	XT1 oscillator operating	External clock from EXCLKS pin is valid	Input port
1	XT1 oscillator stopped	External clock from EXCLKS pin is invalid	

HIOSTOP	High-speed on-chip oscillator clock operation control	
	0	High-speed on-chip oscillator operating
1	High-speed on-chip oscillator stopped	

- Cautions**
1. After reset release, set the clock operation mode control register (CMC) before setting the CSC register.
  2. Set the oscillation stabilization time select register (OSTS) before setting the MSTOP bit to 0 after releasing reset. Note that if the OSTS register is being used with its default settings, the OSTS register is not required to be set here.
  3. To start X1 oscillation as set by the MSTOP bit, check the oscillation stabilization time of the X1 clock by using the oscillation stabilization time counter status register (OSTC).
  4. When starting XT1 oscillation by setting the XSTOP bit, wait for oscillation of the subsystem clock to stabilize by setting a wait time using software.
  5. Do not stop the clock selected for the CPU peripheral hardware clock (f<sub>CLK</sub>) with the OSC register.
  6. The setting of the flags of the register to stop clock oscillation (invalidate the external clock input) and the condition before clock oscillation is to be stopped are as Table 5-2.

**Table 5-2. Stopping Clock Method**

Clock	Condition Before Stopping Clock (Invalidating External Clock Input)	Setting of CSC Register Flags
X1 clock	CPU and peripheral hardware clocks operate with a clock other than the high-speed system clock. (CLS = 0 and MCS = 0, or CLS = 1)	MSTOP = 1
External main system clock		
XT1 clock	CPU and peripheral hardware clocks operate with a clock other than the subsystem clock. (CLS = 0)	XTSTOP = 1
External subsystem clock		
High-speed on-chip oscillator clock	CPU and peripheral hardware clocks operate with a clock other than the high-speed on-chip oscillator clock. (CLS = 0 and MCS = 1, or CLS = 1)	HIOSTOP = 1

**(4) Oscillation stabilization time counter status register (OSTC)**

This is the register that indicates the count status of the X1 clock oscillation stabilization time counter.

The X1 clock oscillation stabilization time can be checked in the following case,

- If the X1 clock starts oscillation while the high-speed on-chip oscillator clock or subsystem clock is being used as the CPU clock.
- If the STOP mode is entered and then released while the high-speed on-chip oscillator clock is being used as the CPU clock with the X1 clock oscillating.

The OSTC register can be read by a 1-bit or 8-bit memory manipulation instruction.

When reset signal is generated, the STOP instruction and MSTOP (bit 7 of clock operation status control register (CSC)) = 1 clear the OSTC register to 00H.

**Remark** The oscillation stabilization time counter starts counting in the following cases.

- When oscillation of the X1 clock starts (EXCLK, OSCSEL = 0, 1 → MSTOP = 0)
- When the STOP mode is released

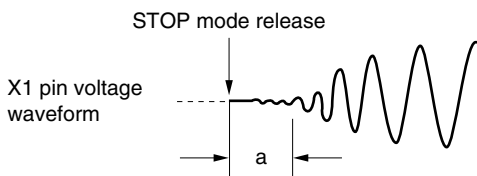
**Figure 5-5. Format of Oscillation Stabilization Time Counter Status Register (OSTC)**

Address: FFFA2H After reset: 00H R

Symbol	7	6	5	4	3	2	1	0
OSTC	MOST 8	MOST 9	MOST 10	MOST 11	MOST 13	MOST 15	MOST 17	MOST 18

MOST 8	MOST 9	MOST 10	MOST 11	MOST 13	MOST 15	MOST 17	MOST 18	Oscillation stabilization time status		
									fx = 10 MHz	fx = 20 MHz
0	0	0	0	0	0	0	0	$2^9/f_x$ max.	25.6 $\mu$ s max.	12.8 $\mu$ s max.
1	0	0	0	0	0	0	0	$2^9/f_x$ min.	25.6 $\mu$ s min.	12.8 $\mu$ s min.
1	1	0	0	0	0	0	0	$2^9/f_x$ min.	51.2 $\mu$ s min.	25.6 $\mu$ s min.
1	1	1	0	0	0	0	0	$2^{10}/f_x$ min.	102.4 $\mu$ s min.	51.2 $\mu$ s min.
1	1	1	1	0	0	0	0	$2^{11}/f_x$ min.	204.8 $\mu$ s min.	102.4 $\mu$ s min.
1	1	1	1	1	0	0	0	$2^{13}/f_x$ min.	819.2 $\mu$ s min.	409.6 $\mu$ s min.
1	1	1	1	1	1	0	0	$2^{15}/f_x$ min.	3.27 ms min.	1.64 ms min.
1	1	1	1	1	1	1	0	$2^{17}/f_x$ min.	13.11 ms min.	6.55 ms min.
1	1	1	1	1	1	1	1	$2^{18}/f_x$ min.	26.21 ms min.	13.11 ms min.

- Cautions**
1. After the above time has elapsed, the bits are set to 1 in order from the MOST8 bit and remain 1.
  2. The oscillation stabilization time counter counts up to the oscillation stabilization time set by the oscillation stabilization time select register (OSTS).  
In the following cases, set the oscillation stabilization time of the OSTS register to the value greater than the count value which is to be checked by the OSTC register.
    - If the X1 clock starts oscillation while the high-speed on-chip oscillator clock or subsystem clock is being used as the CPU clock.
    - If the STOP mode is entered and then released while the high-speed on-chip oscillator clock is being used as the CPU clock with the X1 clock oscillating.  
(Note, therefore, that only the status up to the oscillation stabilization time set by the OSTS register is set to the OSTC register after the STOP mode is released.)
  3. The X1 clock oscillation stabilization wait time does not include the time until clock oscillation starts (“a” below).



**Remark** fx: X1 clock oscillation frequency



**(5) Oscillation stabilization time select register (OSTS)**

This register is used to select the X1 clock oscillation stabilization wait time when the STOP mode is released.

When the X1 clock is selected as the CPU clock, the operation automatically waits for the time set using the OSTS register after the STOP mode is released.

When the high-speed on-chip oscillator clock is selected as the CPU clock, confirm with the oscillation stabilization time counter status register (OSTC) that the desired oscillation stabilization time has elapsed after the STOP mode is released. The oscillation stabilization time can be checked up to the time set using the OSTC register.

The OSTS register can be set by an 8-bit memory manipulation instruction.

Reset signal generation sets the OSTS register to 07H.

**Figure 5-6. Format of Oscillation Stabilization Time Select Register (OSTS)**

Address: FFFA3H After reset: 07H R/W

Symbol	7	6	5	4	3	2	1	0
OSTS	0	0	0	0	0	OSTS2	OSTS1	OSTS0

OSTS2	OSTS1	OSTS0	Oscillation stabilization time selection	Oscillation stabilization time selection	
				$f_x = 10 \text{ MHz}$	$f_x = 20 \text{ MHz}$
0	0	0	$2^8/f_x$	25.6 $\mu\text{s}$	12.8 $\mu\text{s}$
0	0	1	$2^9/f_x$	51.2 $\mu\text{s}$	25.6 $\mu\text{s}$
0	1	0	$2^{10}/f_x$	102.4 $\mu\text{s}$	51.2 $\mu\text{s}$
0	1	1	$2^{11}/f_x$	204.8 $\mu\text{s}$	102.4 $\mu\text{s}$
1	0	0	$2^{13}/f_x$	819.2 $\mu\text{s}$	409.6 $\mu\text{s}$
1	0	1	$2^{15}/f_x$	3.27 ms	1.64 ms
1	1	0	$2^{17}/f_x$	13.11 ms	6.55 ms
1	1	1	$2^{18}/f_x$	26.21 ms	13.11 ms

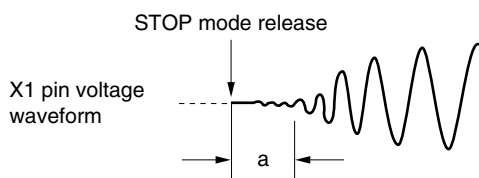
<R>

- Cautions**
1. To set the STOP mode when the X1 clock is used as the CPU clock, set the OSTS register before executing the STOP instruction.
  2. Change the setting of the OSTS register before setting the MSTOP bit of the clock operation status control register (CSC) to 0.
  3. Do not change the value of the OSTS register during the X1 clock oscillation stabilization time.
  4. The oscillation stabilization time counter counts up to the oscillation stabilization time set by the OSTS register.

In the following cases, set the oscillation stabilization time of the OSTS register to the value greater than the count value which is to be checked by the OSTC register after the oscillation starts.

- If the X1 clock starts oscillation while the high-speed on-chip oscillator clock or subsystem clock is being used as the CPU clock.
- If the STOP mode is entered and then released while the high-speed on-chip oscillator clock is being used as the CPU clock with the X1 clock oscillating. (Note, therefore, that only the status up to the oscillation stabilization time set by the OSTS register is set to the OSTC register after the STOP mode is released.)

5. The X1 clock oscillation stabilization wait time does not include the time until clock oscillation starts (“a” below).



**Remark**  $f_x$ : X1 clock oscillation frequency

**(6) Peripheral enable register 0 (PER0)**

These registers are used to enable or disable supplying the clock to the peripheral hardware. Clock supply to the hardware that is not used is also stopped so as to decrease the power consumption and noise.

To use the peripheral functions below, which are controlled by this register, set (1) the bit corresponding to each function before specifying the initial settings of the peripheral functions.

- Real-time clock, interval timer
- Serial interface IICA1
- A/D converter
- Serial interface IICA0
- Serial array unit 1
- Serial array unit 0
- Timer array unit 1
- Timer array unit 0

The PER0 register can be set by a 1-bit or 8-bit memory manipulation instruction.

Reset signal generation clears these registers to 00H.

**Figure 5-7. Format of Peripheral Enable Register 0 (PER0) (1/3)**

Address: F00F0H After reset: 00H R/W

Symbol	<7>	<6>	<5>	<4>	<3>	<2>	<1>	<0>
PER0	RTCEN	IICA1EN <small>Note 1</small>	ADCEN	IICA0EN <small>Note 2</small>	SAU1EN <small>Note 3</small>	SAU0EN	TAU1EN <small>Note 1</small>	TAU0EN

<R>

RTCEN	Control of real-time clock (RTC) and interval timer input clock supply
0	Stops input clock supply. • SFR used by the real-time clock (RTC) and interval timer cannot be written. • The real-time clock (RTC) and interval timer are in the reset status.
1	Enables input clock supply. • SFR used by the real-time clock (RTC) and interval timer can be read and written.
IICA1EN	Control of serial interface IICA1 input clock supply
0	Stops input clock supply. • SFR used by the serial interface IICA1 cannot be written. • The serial interface IICA1 is in the reset status.
1	Enables input clock supply. • SFR used by the serial interface IICA1 can be read and written.

- Notes 1.** 80, 100, and 128-pin products only.
- 2.** This is not provided in the 20-pin products.
- 3.** This is not provided in the 20, 24, and 25-pin products.

**Caution** Be sure to clear the following bits to 0.

**20-pin products: bits 1, 3, 4, 6**

**24, 25-pin products: bits 1, 3, 6**

**30, 32, 36, 40, 44, 48, 52, 64-pin products: bits 1, 6**

**Figure 5-7. Format of Peripheral Enable Register 0 (PER0) (2/3)**

Address: F00F0H After reset: 00H R/W

Symbol	<7>	<6>	<5>	<4>	<3>	<2>	<1>	<0>
PER0	RTCEN	IICA1EN <small>Note 1</small>	ADCEN	IICA0EN <small>Note 2</small>	SAU1EN <small>Note 3</small>	SAU0EN	TAU1EN <small>Note 1</small>	TAU0EN

ADCEN	Control of A/D converter input clock supply
0	Stops input clock supply. <ul style="list-style-type: none"> <li>• SFR used by the A/D converter cannot be written.</li> <li>• The A/D converter is in the reset status.</li> </ul>
1	Enables input clock supply. <ul style="list-style-type: none"> <li>• SFR used by the A/D converter can be read and written.</li> </ul>

IICA0EN	Control of serial interface IICA0 input clock supply
0	Stops input clock supply. <ul style="list-style-type: none"> <li>• SFR used by the serial interface IICA0 cannot be written.</li> <li>• The serial interface IICA0 is in the reset status.</li> </ul>
1	Enables input clock supply. <ul style="list-style-type: none"> <li>• SFR used by the serial interface IICA0 can be read and written.</li> </ul>

SAU1EN	Control of serial array unit 1 input clock supply
0	Stops input clock supply. <ul style="list-style-type: none"> <li>• SFR used by the serial array unit 1 cannot be written.</li> <li>• The serial array unit 1 is in the reset status.</li> </ul>
1	Enables input clock supply. <ul style="list-style-type: none"> <li>• SFR used by the serial array unit 1 can be read and written.</li> </ul>

SAU0EN	Control of serial array unit 0 input clock supply
0	Stops input clock supply. <ul style="list-style-type: none"> <li>• SFR used by the serial array unit 0 cannot be written.</li> <li>• The serial array unit 0 is in the reset status.</li> </ul>
1	Enables input clock supply. <ul style="list-style-type: none"> <li>• SFR used by the serial array unit 0 can be read and written.</li> </ul>

- Notes 1.** 80, 100, and 128-pin products only.  
**2.** This is not provided in the 20-pin products.  
**3.** This is not provided in the 20, 24, and 25-pin products.

**Caution** Be sure to clear the following bits to 0.  
**20-pin products: bits 1, 3, 4, 6**  
**24, 25-pin products: bits 1, 3, 6**  
**30, 32, 36, 40, 44, 48, 52, 64-pin products: bits 1, 6**

**Figure 5-7. Format of Peripheral Enable Register 0 (PER0) (3/3)**

Address: F00F0H After reset: 00H R/W

Symbol	<7>	<6>	<5>	<4>	<3>	<2>	<1>	<0>
PER0	RTCEN	IICA1EN <small>Note 1</small>	ADCEN	IICA0EN <small>Note 2</small>	SAU1EN <small>Note 3</small>	SAU0EN	TAU1EN <small>Note 1</small>	TAU0EN

TAU1EN	Control of timer array unit 1 input clock supply
0	Stops input clock supply. <ul style="list-style-type: none"> <li>• SFR used by timer array unit 1 cannot be written.</li> <li>• Timer array unit 1 is in the reset status.</li> </ul>
1	Enables input clock supply. <ul style="list-style-type: none"> <li>• SFR used by timer array unit 1 can be read and written.</li> </ul>

TAU0EN	Control of timer array unit 0 input clock supply
0	Stops input clock supply. <ul style="list-style-type: none"> <li>• SFR used by timer array unit 0 cannot be written.</li> <li>• Timer array unit 0 is in the reset status.</li> </ul>
1	Enables input clock supply. <ul style="list-style-type: none"> <li>• SFR used by timer array unit 0 can be read and written.</li> </ul>

- Notes**
1. 80, 100, and 128-pin products only.
  2. This is not provided in the 20-pin products.
  3. This is not provided in the 20, 24, and 25-pin products.

**Caution** Be sure to clear the following bits to 0.

- 20-pin products: bits 1, 3, 4, 6
- 24, 25-pin products: bits 1, 3, 6
- 30, 32, 36, 40, 44, 48, 52, 64-pin products: bits 1, 6

**(7) Operation speed mode control register (OSMC)**

This register is used to reduce power consumption by stopping unnecessary clock functions.

If the RTCLPC bit is set to 1, power consumption can be reduced, because clock supply to the peripheral functions, except the real-time clock and interval timer, is stopped in STOP mode or HALT mode while subsystem clock is selected as CPU clock. Set bit 7 (RTCEN) of peripheral enable registers 0 (PER0) to 1 before this setting.

<R>

In addition, the OSMC register can be used to select the operation clock of the real-time clock and interval timer.

The OSMC register can be set by an 8-bit memory manipulation instruction.

Reset signal generation clears this register to 00H.

**Figure 5-8. Format of Operation Speed Mode Control Register (OSMC)**

Address: F00F3H After reset: 00H R/W

Symbol	7	6	5	4	3	2	1	0
OSMC	RTCLPC	0	0	WUTMMCK0	0	0	0	0

RTCLPC	Setting in STOP mode or HALT mode while subsystem clock is selected as CPU clock
0	Enables supply of subsystem clock to peripheral functions (See Table 18-1 for peripheral functions whose operations are enabled.)
1	Stops supply of subsystem clock to peripheral functions other than real-time clock and interval timer.

WUTMMCK0	Selection of operation clock for real-time clock and interval timer.
0	Subsystem clock ( $f_{SUB}$ )
1	Low-speed on-chip oscillator clock ( $f_{L}$ )

**Caution** The STOP mode current or HALT mode current when the subsystem clock is used can be reduced by setting the RTCLPC bit to 1. However, no clock can be supplied to the peripheral functions other than the real-time clock and interval timer during HALT mode while subsystem clock is selected as CPU clock.

**(8) High-speed on-chip oscillator frequency select register (HOCODIV)**

The frequency of the high-speed on-chip oscillator which is set by an option byte (000C2H/0102CH) can be changed by using high-speed on-chip oscillator frequency select register (HOCODIV). However, the selectable frequency depends on the FRQSEL3 bit of the option byte (000C2H/0102CH).

The HOCODIV register can be set by an 8-bit memory manipulation instruction.

Reset signal generation clears this register to default value (undefined).

**Figure 5-9. Format of High-speed On-chip Oscillator Frequency Select Register (HOCODIV)**

Address: F00A8H After reset: undefined R/W

Symbol	7	6	5	4	3	2	1	0
HOCODIV	0	0	0	0	0	HOCODIV2	HOCODIV1	HOCODIV0

HOCODIV2	HOCODIV1	HOCODIV0	High-Speed On-Chip Oscillator Clock Frequency	
			FRQSEL3 Bit is 0	FRQSEL3 Bit of is 1
0	0	0	24 MHz	32 MHz
0	0	1	12 MHz	16 MHz
0	1	0	6 MHz	8 MHz
0	1	1	3 MHz	4 MHz
1	0	0	Setting prohibited	2 MHz
1	0	1	Setting prohibited	1 MHz
Other than aboves			Setting prohibited	

- Cautions**
1. Set the HOCODIV register within the operable voltage range both before and after changing the frequency.
  2. Use the device within the voltage of the flash operation mode set by the option byte (000C2H/010C2H) even after the frequency has been changed by using the HOCODIV register.

Option Byte (000C2H/010C2H) Value		Flash Operation Mode	Operating Frequency Range	Operating Voltage Range
CMODE1	CMODE2			
0	0	LV (low-voltage main) mode	1 to 4 MHz	1.6 to 5.5 V
1	0	LS (low-speed main) mode	1 to 8 MHz	1.8 to 5.5 V
1	1	HS (high-speed main) mode	1 to 16 MHz	2.4 to 5.5 V
			1 to 32 MHz	2.7 to 5.5 V

<R>

<R>

3. When setting of high-speed on-chip oscillator clock as system clock, the device operates at the old frequency for the duration of 3 clocks after the frequency value has been changed by using the HOCODIV register.
4. To change the frequency of the high-speed on-chip oscillator when X1 oscillation, external oscillation input or subclock is set for the system clock, stop the high-speed on-chip oscillator by setting bit 0 (HIOSTOP) of the CSC register to 1 and then change the frequency.

**(9) High-speed on-chip oscillator trimming register (HIOTRM)**

This register is used to adjust the accuracy of the high-speed on-chip oscillator.

<R> With self-measurement of the high-speed on-chip oscillator frequency via a timer using high-accuracy external clock input (timer array unit), and so on, the accuracy can be adjusted.  
 The HIOTRM register can be set by an 8-bit memory manipulation instruction.

<R> **Caution** The frequency will vary if the temperature and V<sub>DD</sub> pin voltage change after accuracy adjustment. When the temperature and V<sub>DD</sub> voltage change, accuracy adjustment must be executed regularly or before the frequency accuracy is required.

**Figure 5-10. Format of High-Speed On-Chip Oscillator Trimming Register (HIOTRM)**

Address: F00A0H After reset: **Note** R/W

Symbol	7	6	5	4	3	2	1	0
HIOTRM	0	0	HIOTRM5	HIOTRM4	HIOTRM3	HIOTRM2	HIOTRM1	HIOTRM0

HIOTRM5	HIOTRM4	HIOTRM3	HIOTRM2	HIOTRM1	HIOTRM0	High-speed on-chip oscillator
0	0	0	0	0	0	Minimum speed
0	0	0	0	0	1	↑ ↓
0	0	0	0	1	0	
0	0	0	0	1	1	
0	0	0	1	0	0	
• • •						
1	1	1	1	1	0	↓
1	1	1	1	1	1	

<R> **Note** The reset value differs for each chip.



## 5.4 System Clock Oscillator

### 5.4.1 X1 oscillator

The X1 oscillator oscillates with a crystal resonator or ceramic resonator (1 to 20 MHz) connected to the X1 and X2 pins.

An external clock can also be input. In this case, input the clock signal to the EXCLK pin.

To use the X1 oscillator, set bits 7 and 6 (EXCLK, OSCSEL) of the clock operation mode control register (CMC) as follows.

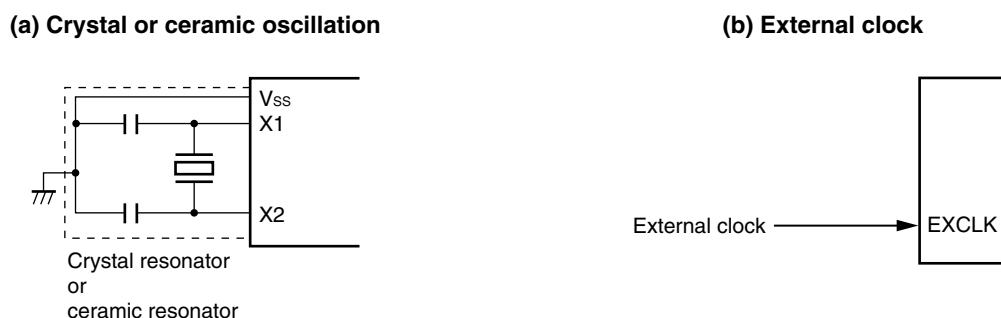
- Crystal or ceramic oscillation: EXCLK, OSCSEL = 0, 1
- External clock input: EXCLK, OSCSEL = 1, 1

When the X1 oscillator is not used, set the input port mode (EXCLK, OSCSEL = 0, 0).

When the pins are not used as input port pins, either, see **Table 2-3 Connection of Unused Pins**.

Figure 5-11 shows an example of the external circuit of the X1 oscillator.

**Figure 5-11. Example of External Circuit of X1 Oscillator**



Cautions are listed on the next page.

### 5.4.2 XT1 oscillator

The XT1 oscillator oscillates with a crystal resonator (standard: 32.768 kHz) connected to the XT1 and XT2 pins.

To use the XT1 oscillator, set bit 4 (OSCSELS) of the clock operation mode control register (CMC) to 1.

An external clock can also be input. In this case, input the clock signal to the EXCLKS pin.

To use the XT1 oscillator, set bits 5 and 4 (EXCLKS, OSCSELS) of the clock operation mode control register (CMC) as follows.

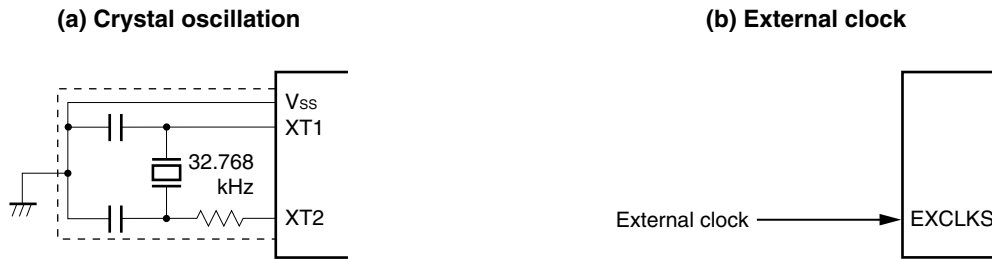
- Crystal or ceramic oscillation: EXCLKS, OSCSELS = 0, 1
- External clock input: EXCLKS, OSCSELS = 1, 1

When the XT1 oscillator is not used, set the input port mode (EXCLKS, OSCSELS = 0, 0).

When the pins are not used as input port pins, either, see **Table 2-3 Connection of Unused Pins**.

Figure 5-12 shows an example of the external circuit of the XT1 oscillator.

Figure 5-12. Example of External Circuit of XT1 Oscillator



**Caution 1.** When using the X1 oscillator and XT1 oscillator, wire as follows in the area enclosed by the broken lines in the Figures 5-10 and 5-11 to avoid an adverse effect from wiring capacitance.

- Keep the wiring length as short as possible.
- Do not cross the wiring with the other signal lines. Do not route the wiring near a signal line through which a high fluctuating current flows.
- Always make the ground point of the oscillator capacitor the same potential as  $V_{SS}$ . Do not ground the capacitor to a ground pattern through which a high current flows.
- Do not fetch signals from the oscillator.

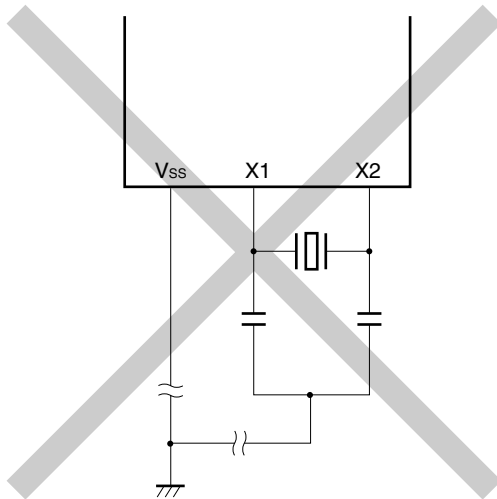
The XT1 oscillator is a circuit with low amplification in order to achieve low-power consumption. Note the following points when designing the circuit.

- Pins and circuit boards include parasitic capacitance. Therefore, perform oscillation evaluation using a circuit board to be actually used and confirm that there are no problems.
- When using the ultra-low power consumption oscillation (AMPHS1, AMPHS0 = 1, 0) as the mode of the XT1 oscillator, use the recommended resonators described in CHAPTER 29 ELECTRICAL SPECIFICATIONS.
- Make the wiring between the XT1 and XT2 pins and the resonators as short as possible, and minimize the parasitic capacitance and wiring resistance. Note this particularly when the ultra-low power consumption oscillation (AMPHS1, AMPHS0 = 1, 0) is selected.
- Configure the circuit of the circuit board, using material with little wiring resistance.
- Place a ground pattern that has the same potential as  $V_{SS}$  as much as possible near the XT1 oscillator.
- Be sure that the signal lines between the XT1 and XT2 pins, and the resonators do not cross with the other signal lines. Do not route the wiring near a signal line through which a high fluctuating current flows.
- The impedance between the XT1 and XT2 pins may drop and oscillation may be disturbed due to moisture absorption of the circuit board in a high-humidity environment or dew condensation on the board. When using the circuit board in such an environment, take measures to damp-proof the circuit board, such as by coating.
- When coating the circuit board, use material that does not cause capacitance or leakage between the XT1 and XT2 pins.

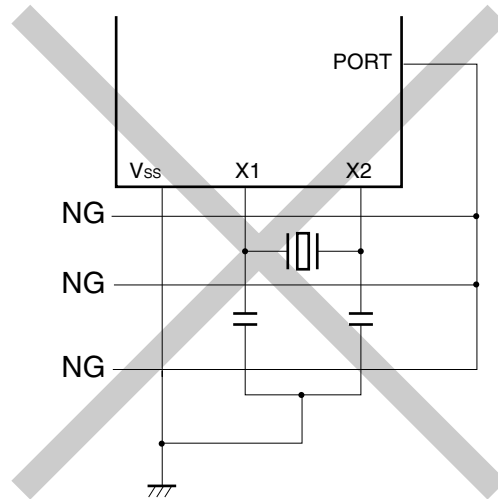
Figure 5-13 shows examples of incorrect resonator connection.

**Figure 5-13. Examples of Incorrect Resonator Connection (1/2)**

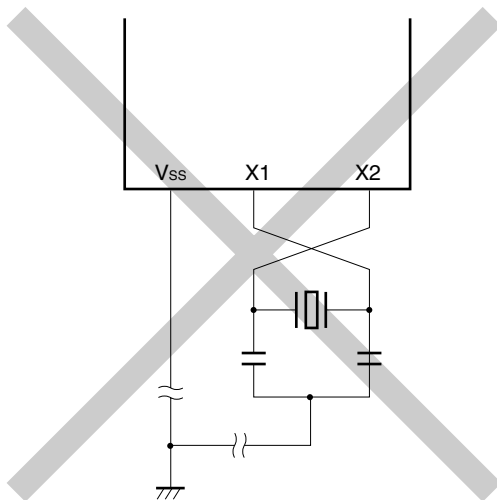
**(a) Too long wiring**



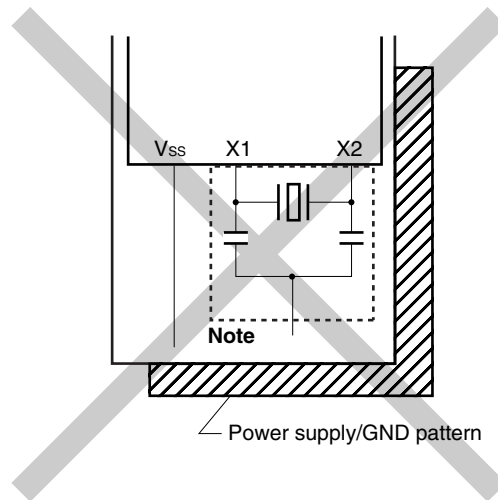
**(b) Crossed signal line**



**(c) The X1 and X2 signal line wires cross.**



**(d) A power supply/GND pattern exists under the X1 and X2 wires.**

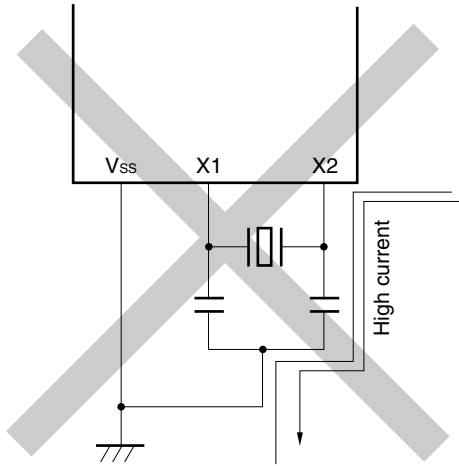


**Note** Do not place a power supply/GND pattern under the wiring section (section indicated by a broken line in the figure) of the X1 and X2 pins and the resonators in a multi-layer board or double-sided board. Do not configure a layout that will cause capacitance elements and affect the oscillation characteristics.

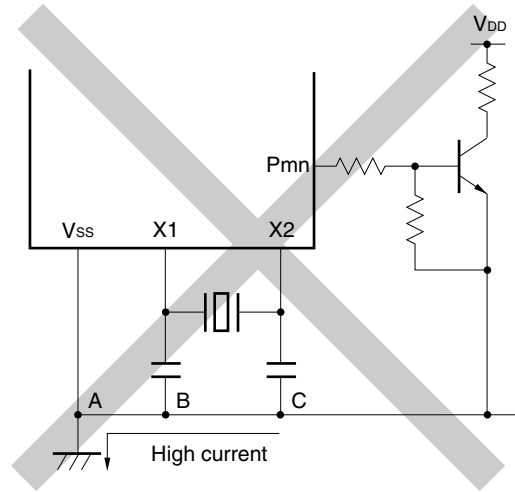
**Remark** When using the subsystem clock, replace X1 and X2 with XT1 and XT2, respectively. Also, insert resistors in series on the XT2 side.

Figure 5-13. Examples of Incorrect Resonator Connection (2/2)

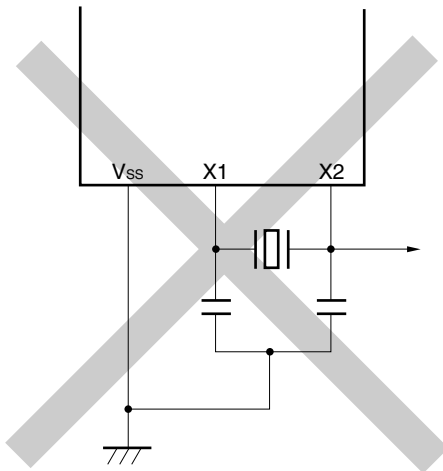
(e) Wiring near high alternating current



(f) Current flowing through ground line of oscillator (potential at points A, B, and C fluctuates)



(g) Signals are fetched



**Caution** When X2 and XT1 are wired in parallel, the crosstalk noise of X2 may increase with XT1, resulting in malfunctioning.

**Remark** When using the subsystem clock, replace X1 and X2 with XT1 and XT2, respectively. Also, insert resistors in series on the XT2 side.

### 5.4.3 High-speed on-chip oscillator

The high-speed on-chip oscillator is incorporated in the RL78/G13. The frequency can be selected from among 32, 24, 16, 12, 8, 4, or 1 MHz by using the option byte (000C2H). Oscillation can be controlled by bit 0 (HI0STOP) of the clock operation status control register (CSC). The high-speed on-chip oscillator automatically starts oscillating after reset release.

### 5.4.4 Low-speed on-chip oscillator

The low-speed on-chip oscillator is incorporated in the RL78/G13.

The low-speed on-chip oscillator clock is used only as the watchdog timer, real-time clock, and interval timer clock. The low-speed on-chip oscillator clock cannot be used as the CPU clock.

This clock operates when bit 4 (WDT0N) of the option byte (000C0H), bit 4 (WUTMMCK0) of the operation speed mode control register (OSMC), or both are set to 1.

Unless the watchdog timer is stopped and WUTMMCK0 is a value other than zero, oscillation of the low-speed on-chip oscillator continues. While the watchdog timer operates, the low-speed on-chip oscillator clock does not stop even if the program freezes.

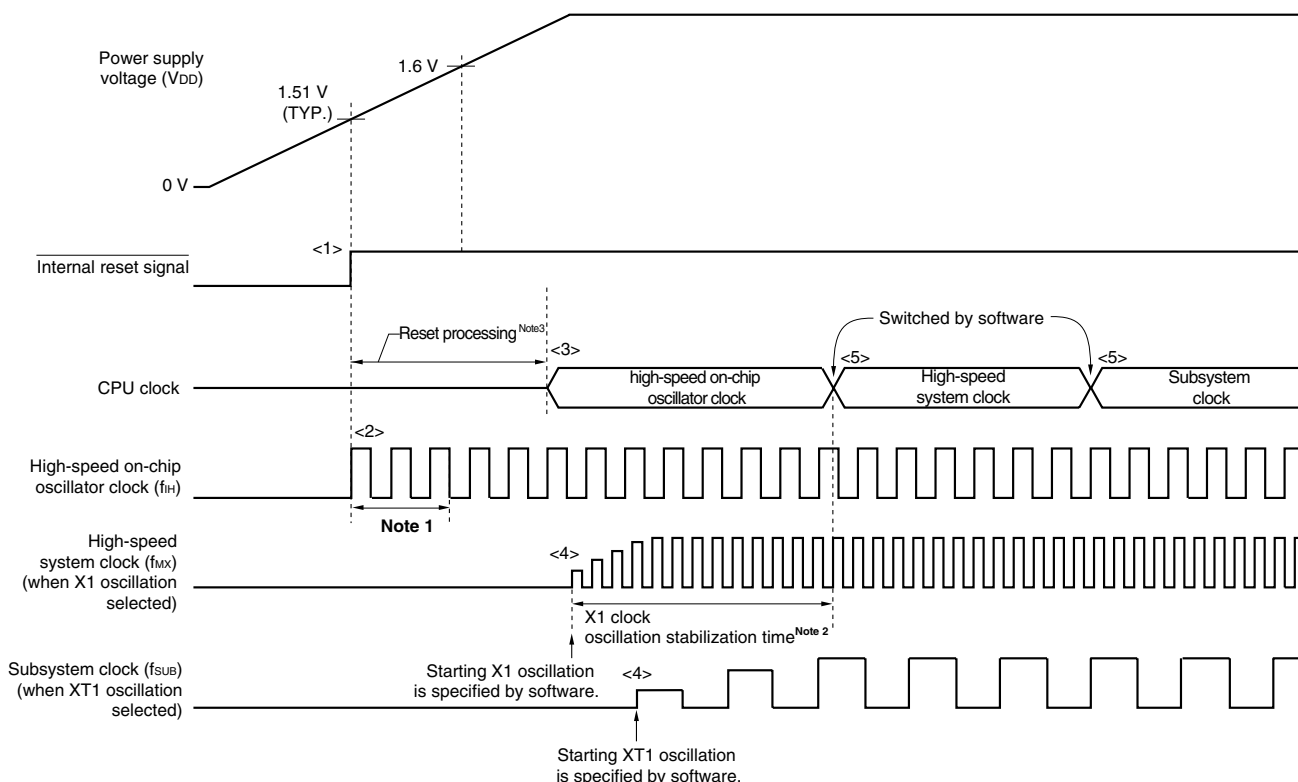
## 5.5 Clock Generator Operation

The clock generator generates the following clocks and controls the operation modes of the CPU, such as standby mode (see **Figure 5-1**).

- Main system clock  $f_{MAIN}$ 
  - High-speed system clock  $f_{MX}$ 
    - X1 clock  $f_X$
    - External main system clock  $f_{EX}$
  - High-speed on-chip oscillator clock  $f_{IH}$
- Subsystem clock  $f_{SUB}$ 
  - XT1 clock  $f_{XT}$
  - External subsystem clock  $f_{EXS}$
- Low-speed on-chip oscillator clock  $f_{IL}$
- CPU/peripheral hardware clock  $f_{CLK}$

The CPU starts operation when the high-speed on-chip oscillator starts outputting after a reset release in the RL78/G13. When the power supply voltage is turned on, the clock generator operation is shown in Figure 5-14.

Figure 5-14. Clock Generator Operation When Power Supply Voltage Is Turned On



- <1> When the power is turned on, an internal reset signal is generated by the power-on-reset (POR) circuit.
- <2> When the power supply voltage exceeds 1.51 V (TYP.), the reset is released and the high-speed on-chip oscillator automatically starts oscillation.
- <3> The CPU starts operation on the high-speed on-chip oscillator clock after a reset processing such as waiting for the voltage of the power supply or regulator to stabilize has been performed after reset release.
- <4> Set the start of oscillation of the X1 or XT1 clock via software (see 5.6.2 Example of setting X1 oscillation clock and 5.6.3 Example of setting XT1 oscillation clock).
- <5> When switching the CPU clock to the X1 or XT1 clock, wait for the clock oscillation to stabilize, and then set switching via software (see 5.6.2 Example of setting X1 oscillation clock and 5.6.3 Example of setting XT1 oscillation clock).

**Notes** 1. The internal reset processing time includes the oscillation accuracy stabilization time of the high-speed on-chip oscillator clock.

2. When releasing a reset, confirm the oscillation stabilization time for the X1 clock using the oscillation stabilization time counter status register (OSTC).

<R> 3. Reset processing time: 387 to 720  $\mu$ s (When LVD is used)  
155 to 407  $\mu$ s (When LVD off)

**Caution** It is not necessary to wait for the oscillation stabilization time when an external clock input from the EXCLK pin is used.

### 5.6 Controlling Clock

#### 5.6.1 Example of setting high-speed on-chip oscillator

After a reset release, the CPU/peripheral hardware clock ( $f_{CLK}$ ) always starts operating with the high-speed on-chip oscillator clock. The frequency of the high-speed on-chip oscillator can be selected from 32, 24, 16, 12, 8, 4, and 1 MHz by using FRQSEL0 to FRQSEL3 of the option byte (000C2H).

[Option byte setting]

Address: 000C2H

Option byte (000C2H)	7	6	5	4	3	2	1	0
	CMODE1	CMODE0			FRQSEL3	FRQSEL2	FRQSEL1	FRQSEL0
	0/1	0/1	1	0	0/1	0/1	0/1	0/1

<R>  
<R>  
<R>

CMODE1	CMODE0	Setting of flash operation mode	
0	0	LV (low voltage main) mode	$V_{DD} = 1.6\text{ V to }5.5\text{ V @ }1\text{ MHz to }4\text{ MHz}$
1	0	LS (low speed main) mode	$V_{DD} = 1.8\text{ V to }5.5\text{ V @ }1\text{ MHz to }8\text{ MHz}$
1	1	HS (high speed main) mode	$V_{DD} = 2.4\text{ V to }5.5\text{ V @ }1\text{ MHz to }16\text{ MHz}$ $V_{DD} = 2.7\text{ V to }5.5\text{ V @ }1\text{ MHz to }32\text{ MHz}$

FRQSEL3	FRQSEL2	FRQSEL1	FRQSEL0	Frequency of the high-speed on-chip oscillator
1	0	0	0	32 MHz
0	0	0	0	24 MHz
1	0	0	1	16 MHz
0	0	0	1	12 MHz
1	0	1	0	8 MHz
1	0	1	1	4 MHz
1	1	0	1	1 MHz
Other than above				Setting prohibited

[High-speed on-chip oscillator frequency select register (HOCODIV) setting]

Address: F00A8H

HOCODIV	7	6	5	4	3	2	1	0
	0	0	0	0	0	HOCODIV2	HOCODIV1	HOCODIV0

HOCODIV2	HOCODIV1	HOCODIV0	Selection of high-speed on-chip oscillator clock frequency	
			FRQSEL3 Bit is 0	FRQSEL3 Bit of is 1
0	0	0	24 MHz	32 MHz
0	0	1	12 MHz	16 MHz
0	1	0	6 MHz	8 MHz
0	1	1	3 MHz	4 MHz
1	0	0	Setting prohibited	2 MHz
1	0	1	Setting prohibited	1 MHz
Other than aboves			Setting prohibited	



### 5.6.2 Example of setting X1 oscillation clock

After a reset release, the CPU/peripheral hardware clock ( $f_{CLK}$ ) always starts operating with the high-speed on-chip oscillator clock. To subsequently change the clock to the X1 oscillation clock, set the oscillator and start oscillation by using the oscillation stabilization time select register (OSTS) and clock operation mode control register (CMC) and clock operation status register (CSC) and wait for oscillation to stabilize by using the oscillation stabilization time counter status register (OSTC). After the oscillation stabilizes, set the X1 oscillation clock to  $f_{CLK}$  by using the system clock control register (CKC).

[Register settings] Set the register in the order of <1> to <5> below.

- <R> <1> Set (1) the OSCSEL bit of the CMC register, except for the cases where the frequency is equal or more than 10MHz, in such cases set (1) the AMPH bit, to operate the X1 oscillator.

	7	6	5	4	3	2	1	0
CMC	EXCLK	OSCSEL	EXCLKS	OSCSELS		AMPHS1	AMPHS0	AMPH
	0	1	0	0	0	0	0	1

AMPH bit: Set this bit to 0 if the X1 oscillation clock is 10 MHz or less.

- <2> Using the OSTS register, select the oscillation stabilization time of the X1 oscillator at releasing of the STOP mode.

Example: Setting values when a wait of at least 102.4  $\mu$ s is set based on a 10 MHz resonator.

	7	6	5	4	3	2	1	0
OSTS						OSTS2	OSTS1	OSTS0
	0	0	0	0	0	0	1	0

- <3> Clear (0) the MSTOP bit of the CSC register to start oscillating the X1 oscillator.

	7	6	5	4	3	2	1	0
CSC	MSTOP	XTSTOP						HIOSTOP
	0	1	0	0	0	0	0	0

- <4> Use the OSTC register to wait for oscillation of the X1 oscillator to stabilize.

Example: Wait until the bits reach the following values when a wait of at least 102.4  $\mu$ s is set based on a 10 MHz resonator.

	7	6	5	4	3	2	1	0
OSTC	MOST8	MOST9	MOST10	MOST11	MOST13	MOST15	MOST17	MOST18
	1	1	1	0	0	0	0	0

- <5> Use the MCM0 bit of the CKC register to specify the X1 oscillation clock as the CPU/peripheral hardware clock.

	7	6	5	4	3	2	1	0
CKC	CLS	CSS	MCS	MCM0				
	0	0	0	1	0	0	0	0

### 5.6.3 Example of setting XT1 oscillation clock

After a reset release, the CPU/peripheral hardware clock ( $f_{CLK}$ ) always starts operating with the high-speed on-chip oscillator clock. To subsequently change the clock to the XT1 oscillation clock, set the oscillator and start oscillation by using the operation speed mode control register (OSMC), clock operation mode control register (CMC), and clock operation status control register (CSC), set the XT1 oscillation clock to  $f_{CLK}$  by using the system clock control register (CKC).

[Register settings] Set the register in the order of <1> to <5> below.

<1> To run only the real-time clock and interval timer on the subsystem clock (ultra-low current consumption) when in the STOP mode or sub-HALT mode, set the RTCLPC bit to 1.

	7	6	5	4	3	2	1	0
OSMC	RTCLPC			WUTMMCK0				
	0/1	0	0	0	0	0	0	0

<2> Set (1) the OSCSELS bit of the CMC register to operate the XT1 oscillator.

	7	6	5	4	3	2	1	0
CMC	EXCLK	OSCSEL	EXCLKS	OSCSELS		AMPHS1	AMPHS0	AMPH
	0	0	0	1	0	0/1	0/1	0

AMPHS0 and AMPHS1 bits: These bits are used to specify the oscillation mode of the XT1 oscillator.

<3> Clear (0) the XTSTOP bit of the CSC register to start oscillating the XT1 oscillator.

	7	6	5	4	3	2	1	0
CSC	MSTOP	XTSTOP						HIOSTOP
	1	0	0	0	0	0	0	0

<4> Use the timer function or another function to wait for oscillation of the subsystem clock to stabilize by using software.

<5> Use the CSS bit of the CKC register to specify the XT1 oscillation clock as the CPU/peripheral hardware clock.

	7	6	5	4	3	2	1	0
CKC	CLS	CSS	MCS	MCM0				
	0	1	0	0	0	0	0	0

5.6.4 CPU clock status transition diagram

Figure 5-15 shows the CPU clock status transition diagram of this product.

Figure 5-15. CPU Clock Status Transition Diagram

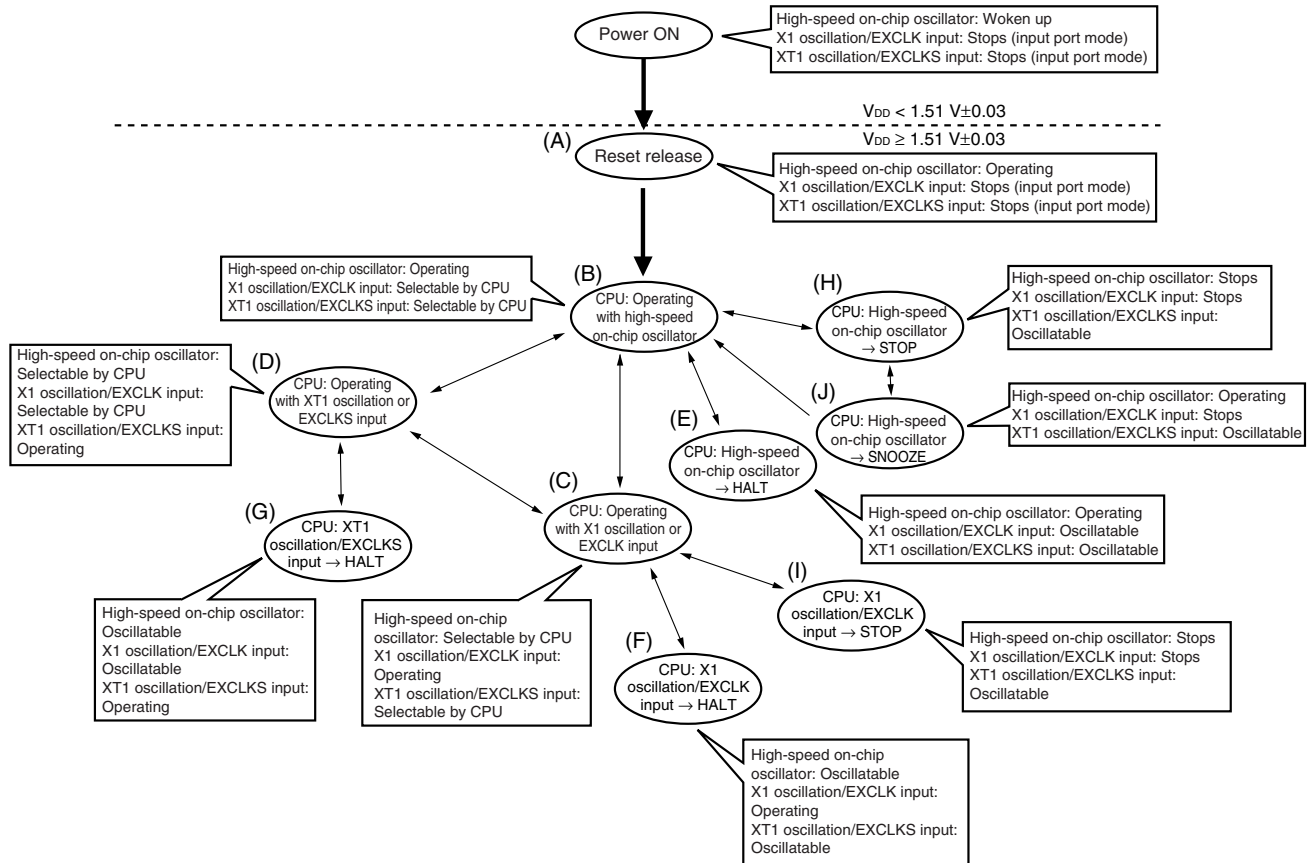


Table 5-3 shows transition of the CPU clock and examples of setting the SFR registers.

**Table 5-3. CPU Clock Transition and SFR Register Setting Examples (1/5)**

**(1) CPU operating with high-speed on-chip oscillator clock (B) after reset release (A)**

Status Transition	SFR Register Setting
(A) → (B)	SFR registers do not have to be set (default status after reset release).

**(2) CPU operating with high-speed system clock (C) after reset release (A)**

(The CPU operates with the high-speed on-chip oscillator clock immediately after a reset release (B).)

(Setting sequence of SFR registers) →

Setting Flag of SFR Register Status Transition	CMC Register <sup>Note</sup>			CSC Register	OSTC Register	CKC Register
	EXCLK	OSCSEL	AMPH	MSTOP		MCM0
(A) → (B) → (C) (X1 clock: 1 MHz ≤ f <sub>x</sub> ≤ 10 MHz)	0	1	0	0	Must be checked	1
(A) → (B) → (C) (X1 clock: 10 MHz < f <sub>x</sub> ≤ 20 MHz)	0	1	1	0	Must be checked	1
(A) → (B) → (C) (external main clock)	1	1	×	0	Must not be checked	1

**Note** The clock operation mode control register (CMC) can be written only once by an 8-bit memory manipulation instruction after reset release.

**Caution** Set the clock after the supply voltage has reached the operable voltage of the clock to be set (see CHAPTER 29 ELECTRICAL SPECIFICATIONS).

**(3) CPU operating with subsystem clock (D) after reset release (A)**

(The CPU operates with the high-speed on-chip oscillator clock immediately after a reset release (B).)

(Setting sequence of SFR registers) →

Setting Flag of SFR Register Status Transition	CMC Register <sup>Note</sup>				CSC Register	Waiting for Oscillation Stabilization	CKC Register
	EXCLKS	OSCSELS	AMPHS1	AMPHS0	XTSTOP		CSS
(A) → (B) → (D) (XT1 clock)	0	1	0/1	0/1	0	Necessary	1
(A) → (B) → (D) (external sub clock)	1	1	×	×	0	Necessary	1

**Note** The clock operation mode control register (CMC) can be written only once by an 8-bit memory manipulation instruction after reset release.

**Remarks** 1. ×: don't care  
2. (A) to (J) in Table 5-3 correspond to (A) to (J) in Figure 5-15.

**Table 5-3. CPU Clock Transition and SFR Register Setting Examples (2/5)**

**(4) CPU clock changing from high-speed on-chip oscillator clock (B) to high-speed system clock (C)**

(Setting sequence of SFR registers) →

Setting Flag of SFR Register Status Transition	CMC Register <sup>Note 1</sup>			OSTS Register	CSC Register	OSTC Register	CKC Register
	EXCLK	OSCSEL	AMPH		MSTOP		
(B) → (C) (X1 clock: 1 MHz ≤ fX ≤ 10 MHz)	0	1	0	<b>Note 2</b>	0	Must be checked	1
(B) → (C) (X1 clock: 10 MHz < fX ≤ 20 MHz)	0	1	1	<b>Note 2</b>	0	Must be checked	1
(B) → (C) (external main clock)	1	1	×	<b>Note 2</b>	0	Must not be checked	1

Unnecessary if these registers are already set
 Unnecessary if the CPU is operating with the high-speed system clock

- Notes**
1. The clock operation mode control register (CMC) can be changed only once after reset release. This setting is not necessary if it has already been set.
  2. Set the oscillation stabilization time as follows.
    - Desired the oscillation stabilization time counter status register (OSTC) oscillation stabilization time ≤ Oscillation stabilization time set by the oscillation stabilization time select register (OSTS)

**Caution** Set the clock after the supply voltage has reached the operable voltage of the clock to be set (see CHAPTER 29 ELECTRICAL SPECIFICATIONS).

**(5) CPU clock changing from high-speed on-chip oscillator clock (B) to subsystem clock (D)**

(Setting sequence of SFR registers) →

Setting Flag of SFR Register Status Transition	CMC Register <sup>Note</sup>		CSC Register	Waiting for Oscillation Stabilization	CKC Register
	EXCLKS	OSCSELS	XTSTOP		CSS
(B) → (D) (XT1 clock)	0	1	0	Necessary	1
(B) → (D) (external sub clock)	1	1	0	Necessary	1

Unnecessary if the CPU is operating with the subsystem clock

**Note** The clock operation mode control register (CMC) can be written only once by an 8-bit memory manipulation instruction after reset release.

- Remarks**
1. ×: don't care
  2. (A) to (J) in Table 5-3 correspond to (A) to (J) in Figure 5-15.

Table 5-3. CPU Clock Transition and SFR Register Setting Examples (3/5)

(6) CPU clock changing from high-speed system clock (C) to high-speed on-chip oscillator clock (B)

(Setting sequence of SFR registers) ▶

Setting Flag of SFR Register	CSC Register	Oscillation accuracy stabilization time	CKC Register
	HIOSTOP		MCM0
Status Transition			
(C) → (B)	0	30 μs	0

<R> } Unnecessary if the CPU is operating with the high-speed on-chip oscillator clock

(7) CPU clock changing from high-speed system clock (C) to subsystem clock (D)

(Setting sequence of SFR registers) ▶

Setting Flag of SFR Register	CSC Register	Waiting for Oscillation Stabilization	CKC Register
	XTSTOP		CSS
Status Transition			
(C) → (D)	0	Necessary	1

} Unnecessary if the CPU is operating with the subsystem clock

(8) CPU clock changing from subsystem clock (D) to high-speed on-chip oscillator clock (B)

(Setting sequence of SFR registers) ▶

Setting Flag of SFR Register	CSC Register	CKC Register	
	HIOSTOP	CSS	MCM0
Status Transition			
(D) → (B)	0	0	0

<R> } Unnecessary if the CPU is operating with the high-speed on-chip oscillator clock } Unnecessary if this register is already set

**Remark** (A) to (J) in Table 5-3 correspond to (A) to (J) in Figure 5-15.

Table 5-3. CPU Clock Transition and SFR Register Setting Examples (4/5)

(9) CPU clock changing from subsystem clock (D) to high-speed system clock (C)

(Setting sequence of SFR registers) →

Setting Flag of SFR Register Status Transition	OSTS Register	CSC Register	OSTC Register	CKC Register	
		MSTOP		CSS	MCM0
(D) → (C) (X1 clock: 1 MHz ≤ f <sub>x</sub> ≤ 10 MHz)	<b>Note</b>	0	Must be checked	0	1
(D) → (C) (X1 clock: 10 MHz < f <sub>x</sub> ≤ 20 MHz)	<b>Note</b>	0	Must be checked	0	1
(D) → (C) (external main clock)	<b>Note</b>	0	Must not be checked	0	1

Unnecessary if the CPU is operating with the high-speed system clock
Unnecessary if these registers are already set

**Note** Set the oscillation stabilization time as follows.

- Desired the oscillation stabilization time counter status register (OSTC) oscillation stabilization time ≤ Oscillation stabilization time set by the oscillation stabilization time select register (OSTS)

**Caution** Set the clock after the supply voltage has reached the operable voltage of the clock to be set (see CHAPTER 29 ELECTRICAL SPECIFICATIONS).

(10) • HALT mode (E) set while CPU is operating with high-speed on-chip oscillator clock (B)

- HALT mode (F) set while CPU is operating with high-speed system clock (C)
- HALT mode (G) set while CPU is operating with subsystem clock (D)

Status Transition	Setting
(B) → (E) (C) → (F) (D) → (G)	Executing HALT instruction

**Remark** (A) to (J) in Table 5-3 correspond to (A) to (J) in Figure 5-15.

Table 5-3. CPU Clock Transition and SFR Register Setting Examples (5/5)

- (11) • STOP mode (H) set while CPU is operating with high-speed on-chip oscillator clock (B)  
 • STOP mode (I) set while CPU is operating with high-speed system clock (C)

(Setting sequence) →

Status Transition		Setting		
(B) → (H)		Stopping peripheral functions that cannot operate in STOP mode	–	Executing STOP instruction
(C) → (I)	In X1 oscillation		Sets the OSTS register	
	External main system clock		–	

(12) CPU changing from STOP mode (H) to SNOOZE mode (J)

For details about the setting for switching from the STOP mode to the SNOOZE mode, see **11.8 SNOOZE Mode Function**, **12.5.7 SNOOZE mode function** and **12.6.3 SNOOZE mode function**.

**Remark** (A) to (J) in Table 5-3 correspond to (A) to (J) in Figure 5-15.



### 5.6.5 Condition before changing CPU clock and processing after changing CPU clock

Condition before changing the CPU clock and processing after changing the CPU clock are shown below.

**Table 5-4. Changing CPU Clock (1/2)**

CPU Clock		Condition Before Change	Processing After Change
Before Change	After Change		
High-speed on-chip oscillator clock	X1 clock	Stabilization of X1 oscillation • OSCSEL = 1, EXCLK = 0, MSTOP = 0 • After elapse of oscillation stabilization time	Operating current can be reduced by stopping high-speed on-chip oscillator (HIOSTOP = 1).
	External main system clock	Enabling input of external clock from the EXCLK pin • OSCSEL = 1, EXCLK = 1, MSTOP = 0	
	XT1 clock	Stabilization of XT1 oscillation • OSCSELS = 1, EXCLKS = 0, XTSTOP = 0 • After elapse of oscillation stabilization time	
	External subsystem clock	Enabling input of external clock from the EXCLKS pin • OSCSELS = 1, EXCLKS = 1, XTSTOP = 0	
X1 clock	High-speed on-chip oscillator clock	Oscillation of high-speed on-chip oscillator • HIOSTOP = 0	X1 oscillation can be stopped (MSTOP = 1).
	External main system clock	Transition not possible (To change the clock, set it again after executing reset once.)	–
	XT1 clock	Stabilization of XT1 oscillation • OSCSELS = 1, EXCLKS = 0, XTSTOP = 0 • After elapse of oscillation stabilization time	X1 oscillation can be stopped (MSTOP = 1).
	External subsystem clock	Enabling input of external clock from the EXCLKS pin • OSCSELS = 1, EXCLKS = 1, XTSTOP = 0	X1 oscillation can be stopped (MSTOP = 1).
External main system clock	High-speed on-chip oscillator clock	Oscillation of high-speed on-chip oscillator • HIOSTOP = 0	External main system clock input can be disabled (MSTOP = 1).
	X1 clock	Transition not possible (To change the clock, set it again after executing reset once.)	–
	XT1 clock	Stabilization of XT1 oscillation • OSCSELS = 1, EXCLKS = 0, XTSTOP = 0 • After elapse of oscillation stabilization time	External main system clock input can be disabled (MSTOP = 1).
	External subsystem clock	Enabling input of external clock from the EXCLKS pin • OSCSELS = 1, EXCLKS = 1, XTSTOP = 0	External main system clock input can be disabled (MSTOP = 1).

Table 5-5. Changing CPU Clock (2/2)

CPU Clock		Condition Before Change	Processing After Change
Before Change	After Change		
XT1 clock	High-speed on-chip oscillator clock	Oscillation of high-speed on-chip oscillator and selection of high-speed on-chip oscillator clock as main system clock • HIOSTOP = 0, MCS = 0	XT1 oscillation can be stopped (XTSTOP = 1)
	X1 clock	Stabilization of X1 oscillation and selection of high-speed system clock as main system clock • OSCSEL = 1, EXCLK = 0, MSTOP = 0 • After elapse of oscillation stabilization time • MCS = 1	
	External main system clock	Enabling input of external clock from the EXCLK pin and selection of high-speed system clock as main system clock • OSCSEL = 1, EXCLK = 1, MSTOP = 0 • MCS = 1	
	External subsystem clock	Transition not possible (To change the clock, set it again after executing reset once.)	–
External subsystem clock	High-speed on-chip oscillator clock	Oscillation of high-speed on-chip oscillator and selection of high-speed on-chip oscillator clock as main system clock • HIOSTOP = 0, MCS = 0	External subsystem clock input can be disabled (XTSTOP = 1).
	X1 clock	Stabilization of X1 oscillation and selection of high-speed system clock as main system clock • OSCSEL = 1, EXCLK = 0, MSTOP = 0 • After elapse of oscillation stabilization time • MCS = 1	
	External main system clock	Enabling input of external clock from the EXCLK pin and selection of high-speed system clock as main system clock • OSCSEL = 1, EXCLK = 1, MSTOP = 0 • MCS = 1	
	XT1 clock	Transition not possible (To change the clock, set it again after executing reset once.)	–

**5.6.6 Time required for switchover of CPU clock and main system clock**

By setting bits 4 and 6 (MCM0, CSS) of the system clock control register (CKC), the CPU clock can be switched (between the main system clock and the subsystem clock), and main system clock can be switched (between the high-speed on-chip oscillator clock and the high-speed system clock).

The actual switchover operation is not performed immediately after rewriting to the CKC register; operation continues on the pre-switchover clock for several clocks (see Table 5-5 to Table 5-7).

Whether the CPU is operating on the main system clock or the subsystem clock can be ascertained using bit 7 (CLS) of the CKC register. Whether the main system clock is operating on the high-speed system clock or high-speed on-chip oscillator clock can be ascertained using bit 5 (MCS) of the CKC register.

When the CPU clock is switched, the peripheral hardware clock is also switched.

**Table 5-5. Maximum Time Required for Main System Clock Switchover**

Clock A	Switching directions	Clock B	Remark
f <sub>IH</sub>	↔	f <sub>MX</sub>	See Table 5-6
f <sub>MAIN</sub>	↔	f <sub>SUB</sub>	See Table 5-7

**Table 5-6. Maximum Number of Clocks Required for f<sub>IH</sub> ↔ f<sub>MX</sub>**

<R>

Set Value Before Switchover		Set Value After Switchover	
MCM0		MCM0	
		0 (f <sub>MAIN</sub> = f <sub>IH</sub> )	1 (f <sub>MAIN</sub> = f <sub>MX</sub> )
0 (f <sub>MAIN</sub> = f <sub>IH</sub> )	f <sub>MX</sub> ≥ f <sub>IH</sub>		2 clock
	f <sub>MX</sub> < f <sub>IH</sub>		2f <sub>IH</sub> /f <sub>MX</sub> clock
1 (f <sub>MAIN</sub> = f <sub>MX</sub> )	f <sub>MX</sub> ≥ f <sub>IH</sub>	2f <sub>MX</sub> /f <sub>IH</sub> clock	
	f <sub>MX</sub> < f <sub>IH</sub>	2 clock	

**Table 5-7. Maximum Number of Clocks Required for f<sub>MAIN</sub> ↔ f<sub>SUB</sub>**

<R>

Set Value Before Switchover		Set Value After Switchover	
CSS		CSS	
		0 (f <sub>CLK</sub> = f <sub>MAIN</sub> )	1 (f <sub>CLK</sub> = f <sub>SUB</sub> )
0 (f <sub>CLK</sub> = f <sub>MAIN</sub> )			1 + 2f <sub>MAIN</sub> /f <sub>SUB</sub> clock
1 (f <sub>CLK</sub> = f <sub>SUB</sub> )		3 clock	

- Remarks 1.** The number of clocks listed in Table 5-6 and Table 5-7 is the number of CPU clocks before switchover.  
**2.** Calculate the number of clocks in **Table 5-6** and **Table 5-7** by removing the decimal portion.

**Example** When switching the main system clock from the high-speed on-chip oscillator clock (when 8 MHz selected) to the high-speed system clock (@ oscillation with f<sub>IH</sub> = 8 MHz, f<sub>MX</sub> = 10 MHz)  
 1 + f<sub>IH</sub>/f<sub>MX</sub> = 1 + 8/10 = 1 + 0.8 = 1.8 → 2 clocks

### 5.6.7 Conditions before clock oscillation is stopped

The following lists the register flag settings for stopping the clock oscillation (disabling external clock input) and conditions before the clock oscillation is stopped.

**Table 5-7. Conditions Before the Clock Oscillation Is Stopped and Flag Settings**

Clock	Conditions Before Clock Oscillation Is Stopped (External Clock Input Disabled)	Flag Settings of SFR Register
High-speed on-chip oscillator clock	MCS = 1 or CLS = 1 (The CPU is operating on a clock other than the high-speed on-chip oscillator clock.)	HIOSTOP = 1
X1 clock	MCS = 0 or CLS = 1 (The CPU is operating on a clock other than the high-speed system clock.)	MSTOP = 1
External main system clock		
XT1 clock	CLS = 0 (The CPU is operating on a clock other than the subsystem clock.)	XTSTOP = 1
External subsystem clock		

## CHAPTER 6 TIMER ARRAY UNIT

The number of units or channels of the timer array unit differs, depending on the product.

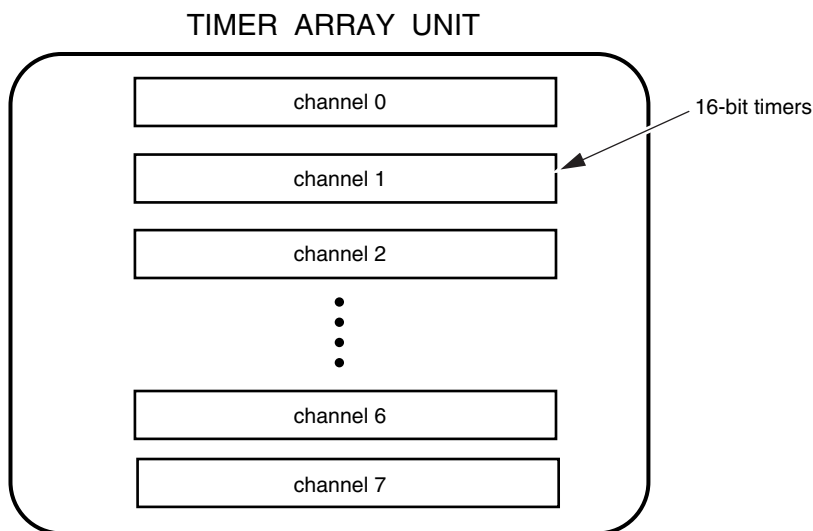
Units	Channels	20, 24, 25, 30, 32, 36, 40, 44, 48, 52, 64-pin	80, 100-pin	128-pin
Unit 0	Channel 0	√	√	√
	Channel 1	√	√	√
	Channel 2	√	√	√
	Channel 3	√	√	√
	Channel 4	√	√	√
	Channel 5	√	√	√
	Channel 6	√	√	√
	Channel 7	√	√	√
Unit 1	Channel 0	–	√	√
	Channel 1	–	√	√
	Channel 2	–	√	√
	Channel 3	–	√	√
	Channel 4	–	–	√
	Channel 5	–	–	√
	Channel 6	–	–	√
	Channel 7	–	–	√

**Cautions 1.** The presence or absence of timer I/O pins depends on the product. See Table 6-2 Timer I/O Pins provided in Each Product for details.

**2.** Most of the following descriptions in this chapter use the 128-pin products as an example.

The timer array unit has eight 16-bit timers.

Each 16-bit timer is called a channel and can be used as an independent timer. In addition, two or more “channels” can be used to create a high-accuracy timer.



For details about each function, see the table below.

Independent channel operation function	Simultaneous channel operation function
<ul style="list-style-type: none"> <li>• Interval timer (→ refer to 6.7.1)</li> <li>• Square wave output (→ refer to 6.7.1)</li> <li>• External event counter (→ refer to 6.7.2)</li> <li>• Divider function <sup>Note</sup> (→ refer to 6.7.3)</li> <li>• Input pulse interval measurement (→ refer to 6.7.4)</li> <li>• Measurement of high-/low-level width of input signal (→ refer to 6.7.5)</li> <li>• Delay counter (→ refer to 6.7.6)</li> </ul>	<ul style="list-style-type: none"> <li>• One-shot pulse output(→ refer to 6.8.1)</li> <li>• PWM output(→ refer to 6.8.2)</li> <li>• Multiple PWM output(→ refer to 6.8.3)</li> </ul>

**Note** Only channel 0 of unit 0.

It is possible to use the 16-bit timer of channels 1 and 3 of the units 0 and 1 as two 8-bit timers (higher and lower). The functions that can use channels 1 and 3 as 8-bit timers are as follows:

- Interval timer
- External event counter (lower 8-bit timer only)
- Delay counter (lower 8-bit timer only)

Channel 7 of unit 0 can be used to realize LIN-bus communication operating in combination with UART2 of the serial array unit (30, 32, 36, 40, 44, 48, 52, 64, 80, 100, and 128-pin products only).

### 6.1 Functions of Timer Array Unit

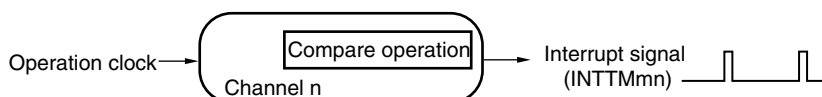
Timer array unit has the following functions.

#### 6.1.1 Independent channel operation function

By operating a channel independently, it can be used for the following purposes without being affected by the operation mode of other channels.

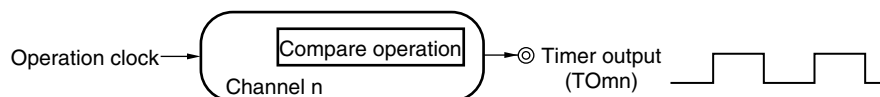
##### (1) Interval timer

Each timer of a unit can be used as a reference timer that generates an interrupt (INTTMmn) at fixed intervals.



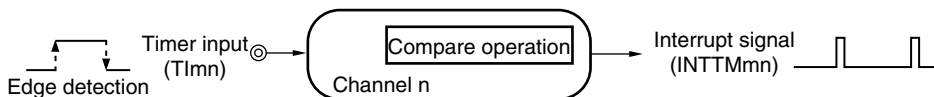
##### (2) Square wave output

A toggle operation is performed each time INTTMmn interrupt is generated and a square wave with a duty factor of 50% is output from a timer output pin (TOMn).



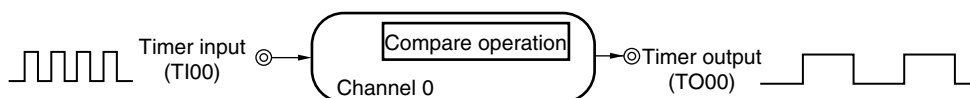
##### (3) External event counter

Each timer of a unit can be used as an event counter that generates an interrupt when the number of the valid edges of a signal input to the timer input pin (TIMn) has reached a specific value.



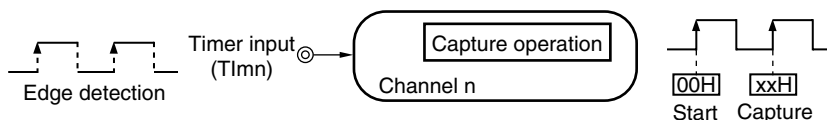
##### (4) Divider function (channel 0 only)

A clock input from a timer input pin (TI00) is divided and output from an output pin (TOM0).



##### (5) Input pulse interval measurement

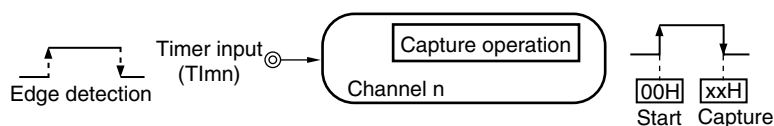
Counting is started by the valid edge of a pulse signal input to a timer input pin (TIMn). The count value of the timer is captured at the valid edge of the next pulse. In this way, the interval of the input pulse can be measured.



(Note, Caution, and Remark are listed on the next page.)

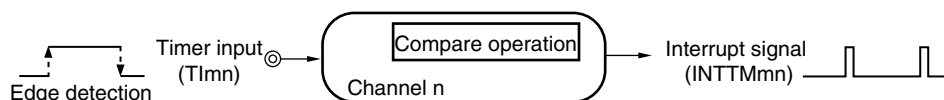
**(6) Measurement of high-/low-level width of input signal**

Counting is started by a single edge of the signal input to the timer input pin (TImn), and the count value is captured at the other edge. In this way, the high-level or low-level width of the input signal can be measured.



**(7) Delay counter**

Counting is started at the valid edge of the signal input to the timer input pin (TImn), and an interrupt is generated after any delay period.



**Remarks 1** n: Channel number (n = 0 to 7)

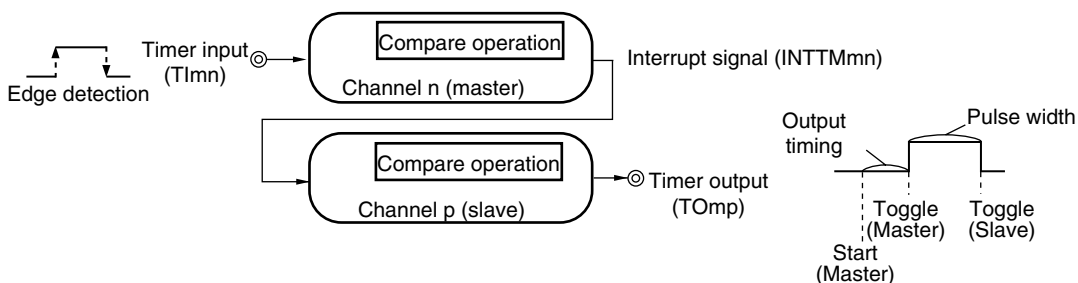
**2.** The presence or absence of timer I/O pins of channel 0 to 7 depends on the product. See **Table 6-2 Timer I/O Pins provided in Each Product** for details.

**6.1.2 Simultaneous channel operation function**

By using the combination of a master channel (a reference timer mainly controlling the cycle) and slave channels (timers operating according to the master channel), channels can be used for the following purposes.

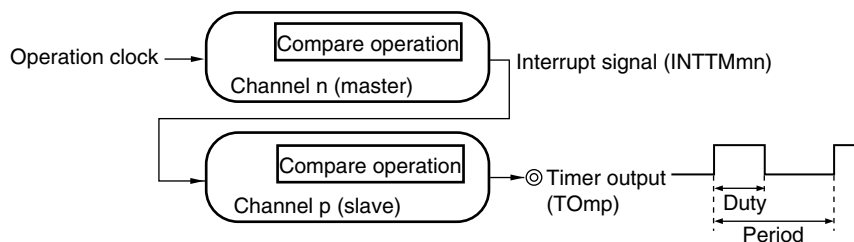
**(1) One-shot pulse output**

Two channels are used as a set to generate a one-shot pulse with a specified output timing and a specified pulse width.



**(2) PWM (Pulse Width Modulation) output**

Two channels are used as a set to generate a pulse with a specified period and a specified duty factor.

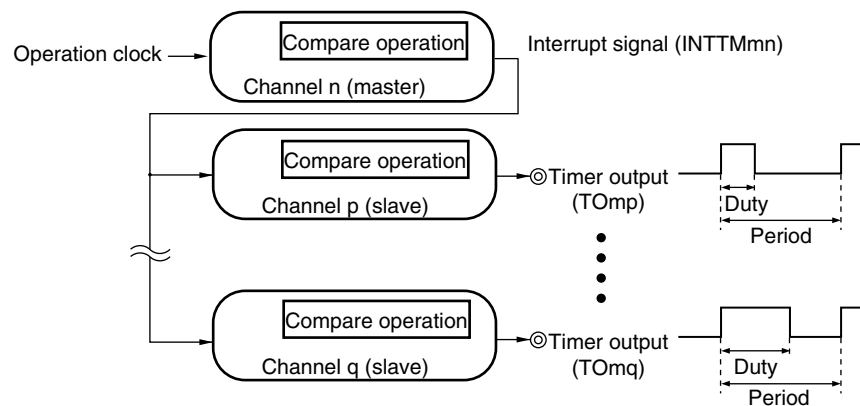


(Caution is listed on the next page.)



### (3) Multiple PWM (Pulse Width Modulation) output

By extending the PWM function and using one master channel and two or more slave channels, up to seven types of PWM signals that have a specific period and a specified duty factor can be generated.



**Caution** The following rules apply when using multiple channels simultaneously.

- Only an even-numbered channel (channel 0, 2, 4, ...) can be specified as the master channel.
- Only channels with lower channel numbers than the master channel can be specified as slave channels (multiple slave channels can be set).

For details about the rules of simultaneous channel operation function, see 6.4.1 Basic rules of simultaneous channel operation function.

**Remark** m: Unit number ( $m = 0, 1$ ), n: Channel number ( $n = 0$  to 7),  
p, q: Slave channel number ( $n < p < q \leq 7$ )

#### 6.1.3 8-bit timer operation function (channels 1 and 3 only)

The 8-bit timer operation function makes it possible to use a 16-bit timer channel in a configuration consisting of two 8-bit timer channels. This function can only be used for channels 1 and 3.

**Caution** There are several rules for using 8-bit timer operation function.

For details, see 6.4.2 Basic rules of 8-bit timer operation function (channels 1 and 3 only).

#### 6.1.4 LIN-bus supporting function (channel 7 of unit 0 only)

Timer array unit is used to check whether signals received in LIN-bus communication match the LIN-bus communication format.

##### (1) Detection of wakeup signal

The timer starts counting at the falling edge of a signal input to the serial data input pin (RxD2) of UART2 and the count value of the timer is captured at the rising edge. In this way, a low-level width can be measured. If the low-level width is greater than a specific value, it is recognized as a wakeup signal.

##### (2) Detection of sync break field

The timer starts counting at the falling edge of a signal input to the serial data input pin (RxD2) of UART2 after a wakeup signal is detected, and the count value of the timer is captured at the rising edge. In this way, a low-level width is measured. If the low-level width is greater than a specific value, it is recognized as a sync break field.

##### (3) Measurement of pulse width of sync field

After a sync break field is detected, the low-level width and high-level width of the signal input to the serial data input pin (RxD2) of UART2 are measured. From the bit interval of the sync field measured in this way, a baud rate is calculated.

**Remark** For details about setting up the operations used to implement the LIN-bus, see **6.3 (13) Input switch control register (ISC)** and **6.7.5 Operation as input signal high-/low-level width measurement**.

## 6.2 Configuration of Timer Array Unit

Timer array unit includes the following hardware.

**Table 6-1. Configuration of Timer Array Unit**

Item	Configuration
Timer/counter	Timer count register mn (TCRmn)
Register	Timer data register mn (TDRmn)
Timer input	TI00 to TI07, TI10 to TI17 <sup>Note 1</sup> , RxD2 pin (for LIN-bus)
Timer output	TO00 to TO07, TO10 to TO17 pins <sup>Note 1</sup> , output controller
Control registers	<p>&lt;Registers of unit setting block&gt;</p> <ul style="list-style-type: none"> <li>• Peripheral enable register 0 (PER0)</li> <li>• Timer clock select register m (TPSm)</li> <li>• Timer channel enable status register m (TEm)</li> <li>• Timer channel start register m (TSm)</li> <li>• Timer channel stop register m (TTm)</li> <li>• Timer input select register 0 (TIS0)</li> <li>• Timer output enable register m (TOEm)</li> <li>• Timer output register m (TOm)</li> <li>• Timer output level register m (TOLm)</li> <li>• Timer output mode register m (TOMm)</li> </ul> <hr/> <p>&lt;Registers of each channel&gt;</p> <ul style="list-style-type: none"> <li>• Timer mode register mn (TMRmn)</li> <li>• Timer status register mn (TSRmn)</li> <li>• Input switch control register (ISC)</li> <li>• Noise filter enable registers 1, 2 (NFEN1, NFEN2)</li> <li>• Port mode register (PMxx)<sup>Note 2</sup></li> <li>• Port register (Pxx)<sup>Note 2</sup></li> </ul>

**Notes** 1. The presence or absence of timer I/O pins of channel 0 to 7 depends on the product. See **Table 6-2 Timer I/O Pins provided in Each Product** for details.

2. The port mode registers (PMxx) and port registers (Pxx) to be set differ depending on the product. for details, see **6.3 (15) Port mode registers 0, 1, 3, 4, 6, 10, 14 (PM0, PM1, PM3, PM4, PM6, PM10, PM14)**.

**Remark** m: Unit number (m = 0, 1), n: Channel number (n = 0 to 7)

The presence or absence of timer I/O pins in each timer array unit channel depends on the product.

<R>

**Table 6-2. Timer I/O Pins provided in Each Product**

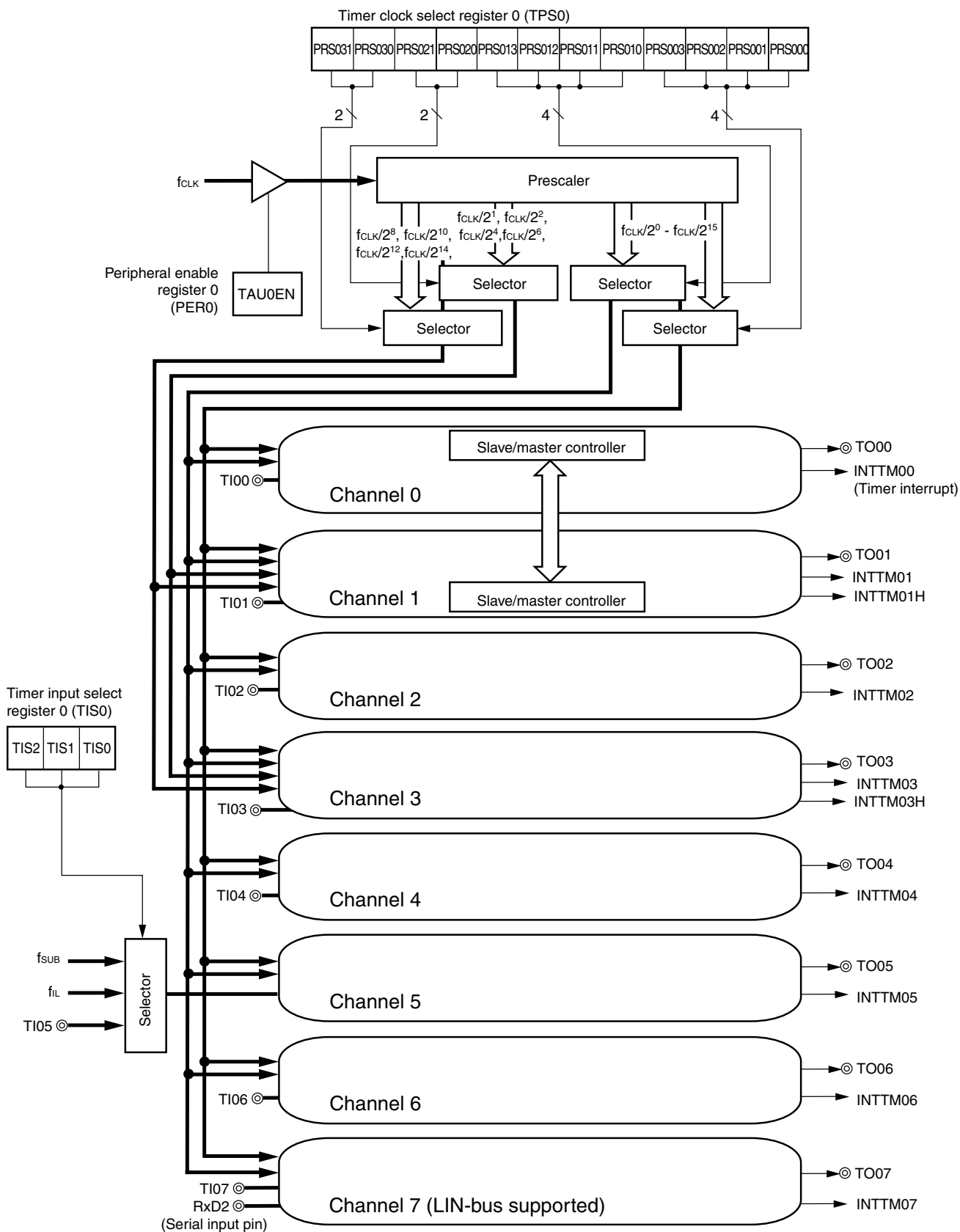
Timer array unit channels		I/O Pins of Each Product									
		128-pin	100-pin	80-pin	64-pin	52-pin	44, 48-pin	40-pin	30, 32, 36-pin	24, 25-pin	20-pin
Unit 0	Channel 0	P00/TI00, P01/TO00									
	Channel 1	P16/TI01/TO01									
	Channel 2	P17/TI02/TO02 <sup>Note</sup>									
	Channel 3	P31/TI03/TO03 <sup>Note</sup>								–	
	Channel 4	P42/TI04/TO04 (P13)			(P13)	(P13)	(P13)	(P13)	–	–	
	Channel 5	P46/TI05/TO05 (P12)		P05/TI05/TO05 (P12)		(P12)	(P12)	(P12)	(P12)	–	–
	Channel 6	P102/TI06/TO06 (P11)		P06/TI06/TO06 (P11)		(P11)	(P11)	(P11)	(P11)	–	–
	Channel 7	P145/TI07/TO07 (P10)		P41/TI07/TO07 (P10)			(P10)	(P10)	–	–	
Unit 1	Channel 0	P64/TI10/TO10		x	x	x	x	x	x	x	
	Channel 1	P65/TI11/TO11		x	x	x	x	x	x	x	
	Channel 2	P66/TI12/TO12		x	x	x	x	x	x	x	
	Channel 3	P67/TI13/TO13		x	x	x	x	x	x	x	
	Channel 4	P103/TI14/TO14	x	x	x	x	x	x	x	x	
	Channel 5	P104/TI15/TO15	x	x	x	x	x	x	x	x	
	Channel 6	P105/TI16/TO16	x	x	x	x	x	x	x	x	
	Channel 7	P106/TI17/TO17		x	x	x	x	x	x	x	

**Note** For 30- to 128-pin products, channel 2 and 3 can be set P15 and P14 with setting the bit 0 of the peripheral I/O redirection register (PIOR) to “1”.

- Remarks**
1. When timer input and timer output are shared by the same pin, either only timer input or only timer output can be used.
  2. –: There is no timer I/O pin, but the channel is available. (However, the channel can only be used as an interval timer.)  
x: The channel is not available.
  3. “(P1x)” indicates an alternate port when the bit 0 of the peripheral I/O redirection register (PIOR) is set to “1”.

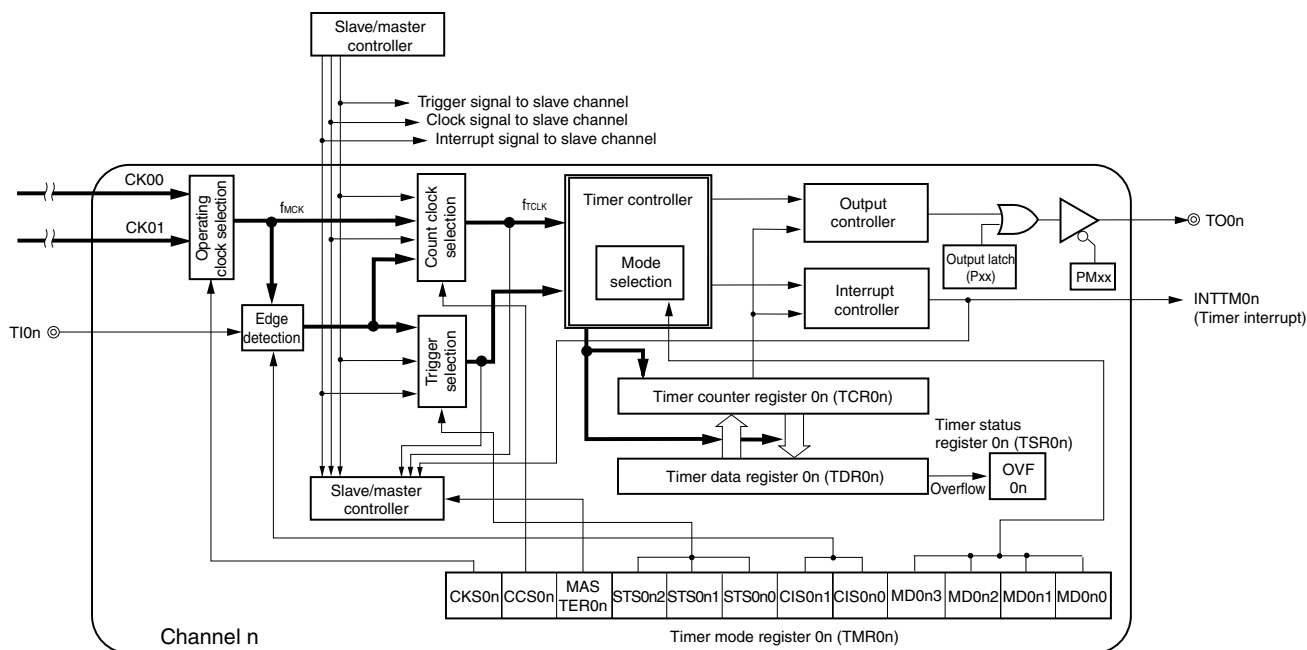
Figures 6-1 and 6-2 show the block diagrams of the timer array unit.

Figure 6-1. Entire Configuration of Timer Array Unit 0 (Example: 64-pin products)



**Remark** f<sub>SUB</sub>: Subsystem clock frequency  
 f<sub>L</sub>: Low-speed on-chip oscillator clock frequency

Figure 6-2. Internal Block Diagram of Channel of Timer Array Unit 0



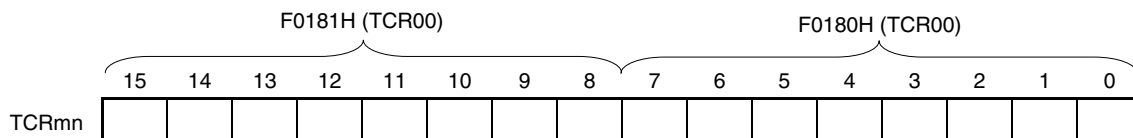
Remark n = 0, 2, 4, 6

(1) Timer count register mn (TCRmn)

The TCRmn register is a 16-bit read-only register and is used to count clocks. The value of this counter is incremented or decremented in synchronization with the rising edge of a count clock. Whether the counter is incremented or decremented depends on the operation mode that is selected by the MDmn3 to MDmn0 bits of timer mode register mn (TMRmn) (refer to 6.3 (3) Timer mode register mn (TMRmn)).

Figure 6-3. Format of Timer Count Register mn (TCRmn)

Address: F0180H, F0181H (TCR00) to F018EH, F018FH (TCR07), After reset: FFFFH R  
 F01C0H, F01C1H (TCR10) to F01CEH, F01CFH (TCR17)



Remark m: Unit number (m = 0, 1), n: Channel number (n = 0 to 7)

The count value can be read by reading timer count register mn (TCRmn).

The count value is set to FFFFH in the following cases.

- When the reset signal is generated
- When the TAUmEN bit of peripheral enable register 0 (PER0) is cleared
- When counting of the slave channel has been completed in the PWM output mode
- When counting of the slave channel has been completed in the delay count mode
- When counting of the master/slave channel has been completed in the one-shot pulse output mode
- When counting of the slave channel has been completed in the multiple PWM output mode

<R>

The count value is cleared to 0000H in the following cases.

- When the start trigger is input in the capture mode
- When capturing has been completed in the capture mode

**Caution** The count value is not captured to timer data register mn (TDRmn) even when the TCRmn register is read.

The TCRmn register read value differs as follows according to operation mode changes and the operating status.

**Table 6-3. Timer Count Register mn (TCRmn) Read Value in Various Operation Modes**

Operation Mode	Count Mode	Timer count register mn (TCRmn) Read Value <sup>Note</sup>			
		Value if the operation mode was changed after releasing reset	Value if the operation mode was changed after count operation paused (TTmn = 1)	Value if the Operation was restarted after count operation paused (TTmn = 1)	Value when waiting for a start trigger after one count
Interval timer mode	Count down	FFFFH	Undefined	Stop value	–
Capture mode	Count up	0000H	Undefined	Stop value	–
Event counter mode	Count down	FFFFH	Undefined	Stop value	–
One-count mode	Count down	FFFFH	Undefined	Stop value	FFFFH
Capture & one-count mode	Count up	0000H	Undefined	Stop value	Capture value of TDRmn register + 1

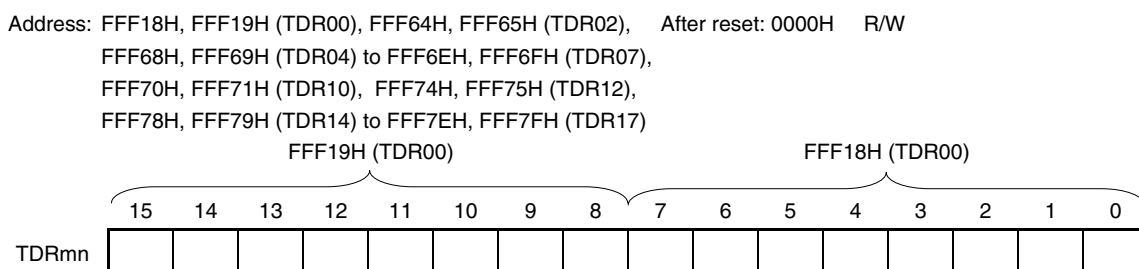
**Note** This indicates the value read from the TCRmn register when channel n has stopped operating as a timer (TEmn = 0) and has been enabled to operate as a counter (TSmn = 1). The read value is held in the TCRmn register until the count operation starts.

**Remark** m: Unit number (m = 0, 1), n: Channel number (n = 0 to 7)

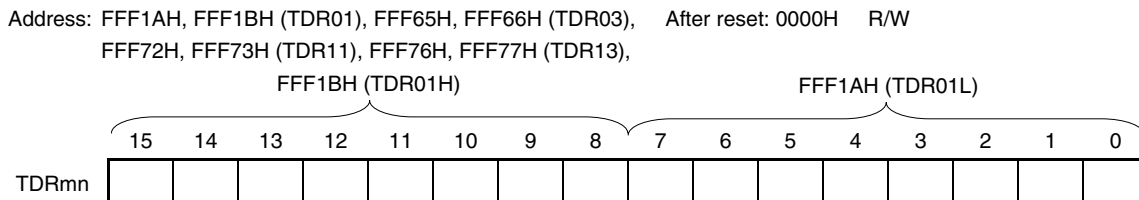
**(2) Timer data register mn (TDRmn)**

This is a 16-bit register from which a capture function and a compare function can be selected. The capture or compare function can be switched by selecting an operation mode by using the MDmn3 to MDmn0 bits of timer mode register mn (TMRmn). The value of the TDRmn register can be changed at any time. This register can be read or written in 16-bit units. In addition, for the TDRm1 and TDRm3 registers, while in the 8-bit timer mode (when the SPLIT bits of timer mode registers 01 and 03 (TMRm1, TMRm3) are 1), it is possible to rewrite the data in 8-bit units, with TDRm1H and TDRm3H used as the higher 8 bits, and TDRm1L and TDRm3L used as the lower 8 bits. However, reading is only possible in 16-bit units. Reset signal generation clears this register to 0000H.

**Figure 6-4. Format of Timer Data Register mn (TDRmn) (n = 0, 2, 4 to 7)**



**Figure 6-5. Format of Timer Data Register mn (TDRmn) (n = 1, 3)**



**(i) When timer data register mn (TDRmn) is used as compare register**

Counting down is started from the value set to the TDRmn register. When the count value reaches 0000H, an interrupt signal (INTTMmn) is generated. The TDRmn register holds its value until it is rewritten.

**Caution** The TDRmn register does not perform a capture operation even if a capture trigger is input, when it is set to the compare function.

**(ii) When timer data register mn (TDRmn) is used as capture register**

The count value of timer count register mn (TCRmn) is captured to the TDRmn register when the capture trigger is input. A valid edge of the TImn pin can be selected as the capture trigger. This selection is made by timer mode register mn (TMRmn).

**Remark** m: Unit number (m = 0, 1), n: Channel number (n = 0 to 7)



### 6.3 Registers Controlling Timer Array Unit

Timer array unit is controlled by the following registers.

- Peripheral enable register 0 (PER0)
- Timer clock select register m (TPSm)
- Timer mode register mn (TMRmn)
- Timer status register mn (TSRmn)
- Timer channel enable status register m (TEm)
- Timer channel start register m (TSm)
- Timer channel stop register m (TTm)
- Timer input select register 0 (TIS0)
- Timer output enable register m (TOEm)
- Timer output register m (TOM)
- Timer output level register m (TOLm)
- Timer output mode register m (TOMm)
- Input switch control register (ISC)
- Noise filter enable registers 1, 2 (NFEN1, NFEN2)
- Port mode register (PMxx)<sup>Note</sup>
- Port register (Pxx)<sup>Note</sup>

**Note** The port mode registers (PMxx) and port registers (Pxx) to be set differ depending on the product. For details, see 6.3 (15) Port mode registers 0, 1, 3, 4, 6, 10, 14 (PM0, PM1, PM3, PM4, PM6, PM10, PM14).

**Remark** m: Unit number (m = 0, 1), n: Channel number (n = 0 to 7)

**(1) Peripheral enable register 0 (PER0)**

This registers is used to enable or disable supplying the clock to the peripheral hardware. Clock supply to a hardware macro that is not used is stopped in order to reduce the power consumption and noise.

When the timer array unit 0 is used, be sure to set bit 0 (TAU0EN) of this register to 1.

When the timer array unit 1 is used, be sure to set bit 1 (TAU1EN) of this register to 1.

The PER0 register can be set by a 1-bit or 8-bit memory manipulation instruction.

Reset signal generation clears this register to 00H.

**Figure 6-6. Format of Peripheral Enable Register 0 (PER0)**

Address: F00F0H After reset: 00H R/W

Symbol	<7>	<6>	<5>	<4>	<3>	<2>	<1>	<0>
PER0	RTCEN	IICA1EN <sup>Note 1</sup>	ADCEN	IICA0EN <sup>Note 2</sup>	SAU1EN <sup>Note 3</sup>	SAU0EN	TAU1EN <sup>Note 1</sup>	TAU0EN

TAU1EN	Control of timer array unit 1 input clock
0	Stops supply of input clock. <ul style="list-style-type: none"> <li>• SFR used by the timer array unit 1 cannot be written.</li> <li>• The timer array unit 1 is in the reset status.</li> </ul>
1	Supplies input clock. <ul style="list-style-type: none"> <li>• SFR used by the timer array unit 1 can be read/written.</li> </ul>

TAU0EN	Control of timer array 0 unit input clock
0	Stops supply of input clock. <ul style="list-style-type: none"> <li>• SFR used by the timer array unit 0 cannot be written.</li> <li>• The timer array unit 0 is in the reset status.</li> </ul>
1	Supplies input clock. <ul style="list-style-type: none"> <li>• SFR used by the timer array unit 0 can be read/written.</li> </ul>

- Notes 1.** 80, 100, and 128-pin products only.
- 2.** This is not provided in the 20-pin products.
- 3.** This is not provided in the 20, 24, and 25-pin products.

- Cautions 1.** When setting the timer array unit, be sure to set the TAUmEN bit to 1 first. If TAUmEN = 0, writing to a control register of timer array unit is ignored, and all read values are default values (except for the timer input select register 0 (TIS0), input switch control register (ISC), noise filter enable register 1, 2 (NFEN1, NFEN2), port mode registers 0, 1, 3, 4, 6, 10, 14 (PM0, PM1, PM3, PM4, PM6, PM10, PM14), and port registers 0, 1, 3, 4, 6, 10, 14 (P0, P1, P3, P4, P6, P10, P14)).
- 2.** Be sure to clear the following bits to 0.
- 20-pin products:** bits 1, 3, 4, 6
- 24, 25-pin products:** bits 1, 3, 6
- 30, 32, 36, 40, 44, 48, 52, 64-pin products:** bits 1, 6

**(2) Timer clock select register m (TPSm)**

<R> The TPSm register is a 16-bit register that is used to select two types or four types of operation clocks (CKm0, CKm1) that are commonly supplied to each channel from external prescaler. CKm1 is selected by using bits 7 to 4 of the TPSm register, and CKm0 is selected by using bits 3 to 0. In addition, for channel 1 and 3, CKm2 is selected by using bits 9 and 8 of the TPSm register, and CKm3 is selected by using bits 13 and 12. Rewriting of the TPSm register during timer operation is possible only in the following cases.

If the PRSm00 to PRSm03 bits can be rewritten (n = 0 to 7):

All channels for which CKm0 is selected as the operation clock (CKSmn1, CKSmn0 = 0, 0) are stopped (TEmn = 0).

If the PRSm10 to PRSm13 bits can be rewritten (n = 0 to 7):

All channels for which CKm1 is selected as the operation clock (CKSmn1, CKSmn0 = 0, 1) are stopped (TEmn = 0).

If the PRSm20 and PRSm21 bits can be rewritten (n = 1, 3):

All channels for which CKm2 is selected as the operation clock (CKSmn1, CKSmn0 = 1, 0) are stopped (TEmn = 0).

If the PRSm30 and PRSm31 bits can be rewritten (n = 1, 3):

All channels for which CKm3 is selected as the operation clock (CKSmn1, CKSmn0 = 1, 1) are stopped (TEmn = 0).

The TPSm register can be set by a 16-bit memory manipulation instruction.

Reset signal generation clears this register to 0000H.

Figure 6-7. Format of Timer Clock Select register m (TPSm) (1/2)

Address: F01B6H, F01B7H (TPS0), F01F6H, F01F7H (TPS1) After reset: 0000H R/W

Symbol	15	14	13	12	11	10	9	8	7	6	5	4	3	2	1	0
TPSm	0	0	PRS m31	PRS m30	0	0	PRS m21	PRS m20	PRS m13	PRS m12	PRS m11	PRS m10	PRS m03	PRS m02	PRS m01	PRS m00

PRS mk3	PRS mk2	PRS mk1	PRS mk0	Selection of operation clock (CKmk) <sup>Note</sup> (k = 0, 1)	Selection of operation clock (CKmk) <sup>Note</sup> (k = 0, 1)				
					f <sub>CLK</sub> = 2 MHz	f <sub>CLK</sub> = 5 MHz	f <sub>CLK</sub> = 10 MHz	f <sub>CLK</sub> = 20 MHz	f <sub>CLK</sub> = 32 MHz
0	0	0	0	f <sub>CLK</sub>	2 MHz	5 MHz	10 MHz	20 MHz	32 MHz
0	0	0	1	f <sub>CLK</sub> /2	1 MHz	2.5 MHz	5 MHz	10 MHz	16 MHz
0	0	1	0	f <sub>CLK</sub> /2 <sup>2</sup>	500 kHz	1.25 MHz	2.5 MHz	5 MHz	8 MHz
0	0	1	1	f <sub>CLK</sub> /2 <sup>3</sup>	250 kHz	625 kHz	1.25 MHz	2.5 MHz	4 MHz
0	1	0	0	f <sub>CLK</sub> /2 <sup>4</sup>	125 kHz	312.5 kHz	625 kHz	1.25 MHz	2 MHz
0	1	0	1	f <sub>CLK</sub> /2 <sup>5</sup>	62.5 kHz	156.2 kHz	312.5 kHz	625 kHz	1 MHz
0	1	1	0	f <sub>CLK</sub> /2 <sup>6</sup>	31.25 kHz	78.1 kHz	156.2 kHz	312.5 kHz	500 kHz
0	1	1	1	f <sub>CLK</sub> /2 <sup>7</sup>	15.62 kHz	39.1 kHz	78.1 kHz	156.2 kHz	250 kHz
1	0	0	0	f <sub>CLK</sub> /2 <sup>8</sup>	7.81 kHz	19.5 kHz	39.1 kHz	78.1 kHz	125 kHz
1	0	0	1	f <sub>CLK</sub> /2 <sup>9</sup>	3.91 kHz	9.76 kHz	19.5 kHz	39.1 kHz	62.5 kHz
1	0	1	0	f <sub>CLK</sub> /2 <sup>10</sup>	1.95 kHz	4.88 kHz	9.76 kHz	19.5 kHz	31.25 kHz
1	0	1	1	f <sub>CLK</sub> /2 <sup>11</sup>	976 Hz	2.44 kHz	4.88 kHz	9.76 kHz	15.63 kHz
1	1	0	0	f <sub>CLK</sub> /2 <sup>12</sup>	488 Hz	1.22 kHz	2.44 kHz	4.88 kHz	7.81 kHz
1	1	0	1	f <sub>CLK</sub> /2 <sup>13</sup>	244 Hz	610 Hz	1.22 kHz	2.44 kHz	3.91 kHz
1	1	1	0	f <sub>CLK</sub> /2 <sup>14</sup>	122 Hz	305 Hz	610 Hz	1.22 kHz	1.95 kHz
1	1	1	1	f <sub>CLK</sub> /2 <sup>15</sup>	61 Hz	153 Hz	305 Hz	610 Hz	976 Hz

**Note** When changing the clock selected for f<sub>CLK</sub> (by changing the system clock control register (CKC) value), stop timer array unit (TTm = 00FFH).

The timer array unit must also be stopped if the operating clock (f<sub>MCK</sub>) specified by using the CKSmn0 and CKSmn1 bits or the valid edge of the signal input from the TImn pin is selected as the count clock (f<sub>TCLK</sub>).

**Caution** Be sure to clear bits 15, 14, 11, 10 to “0”.

- Remarks**
- f<sub>CLK</sub>: CPU/peripheral hardware clock frequency
  - The above f<sub>CLK</sub>/2<sup>m</sup> is not a signal which is simply divided f<sub>CLK</sub> by 2<sup>m</sup>, but a signal which becomes high level for one period of f<sub>CLK</sub> from its rising edge (m = 1 to 15). For details, see 6.5.1 Count clock (f<sub>TCLK</sub>).

Figure 6-7. Format of Timer Clock Select register m (TPSm) (2/2)

Address: F01B6H, F01B7H (TPS0), F01F6H, F01F7H (TPS1) After reset: 0000H R/W

Symbol	15	14	13	12	11	10	9	8	7	6	5	4	3	2	1	0
TPSm	0	0	PRS m31	PRS m30	0	0	PRS m21	PRS m20	PRS m13	PRS m12	PRS m11	PRS m10	PRS m03	PRS m02	PRS m01	PRS m00

PRS m21	PRS m20	Selection of operation clock (CKm2) <sup>Note</sup>					
		$f_{CLK} = 2 \text{ MHz}$	$f_{CLK} = 5 \text{ MHz}$	$f_{CLK} = 10 \text{ MHz}$	$f_{CLK} = 20 \text{ MHz}$	$f_{CLK} = 32 \text{ MHz}$	
0	0	$f_{CLK}/2$	1 MHz	2.5 MHz	5 MHz	10 MHz	16 MHz
0	1	$f_{CLK}/2^2$	500 kHz	1.25 MHz	2.5 MHz	5 MHz	8 MHz
1	0	$f_{CLK}/2^4$	125 kHz	312.5 kHz	625 MHz	1.25 MHz	2 MHz
1	1	$f_{CLK}/2^6$	31.25 kHz	78.1 kHz	156.2 kHz	312.5 kHz	500 kHz

PRS m31	PRS m30	Selection of operation clock (CKm3) <sup>Note</sup>					
		$f_{CLK} = 2 \text{ MHz}$	$f_{CLK} = 5 \text{ MHz}$	$f_{CLK} = 10 \text{ MHz}$	$f_{CLK} = 20 \text{ MHz}$	$f_{CLK} = 32 \text{ MHz}$	
0	0	$f_{CLK}/2^8$	7.81 kHz	19.5 kHz	39.1 kHz	78.1 kHz	125 kHz
0	1	$f_{CLK}/2^{10}$	1.95 kHz	4.88 kHz	9.76 kHz	19.5 kHz	31.25 kHz
1	0	$f_{CLK}/2^{12}$	488 Hz	1.22 kHz	2.44 kHz	4.88 kHz	7.81 kHz
1	1	$f_{CLK}/2^{14}$	122 Hz	305 Hz	610 Hz	1.22 kHz	1.95 kHz

**Note** When changing the clock selected for  $f_{CLK}$  (by changing the system clock control register (CKC) value), stop timer array unit (TTm = 00FFH).  
 The timer array unit must also be stopped if the operating clock ( $f_{mCK}$ ) specified by using the CKSmn0, and CKSmn1 bits or the valid edge of the signal input from the TImn pin is selected as the count clock ( $f_{TCLK}$ ).

**Caution** Be sure to clear bits 15, 14, 11, 10 to “0”.

By using channels 1 and 3 in the 8-bit timer mode and specifying CKm2 or CKm3 as the operation clock, the interval times shown in Table 6-4 can be achieved by using the interval timer function.

Table 6-4. Interval Times Available for Operation Clock CKSm2 or CKSm3

Clock		Interval time ( $f_{CLK} = 32 \text{ MHz}$ )			
		$10 \mu\text{s}$ <sup>Note</sup>	$100 \mu\text{s}$ <sup>Note</sup>	$1 \text{ ms}$ <sup>Note</sup>	$10 \text{ ms}$ <sup>Note</sup>
CKm2	$f_{CLK}/2$	√	–	–	–
	$f_{CLK}/2^2$	√	–	–	–
	$f_{CLK}/2^4$	√	√	–	–
	$f_{CLK}/2^6$	√	√	–	–
CKm3	$f_{CLK}/2^8$	–	√	√	–
	$f_{CLK}/2^{10}$	–	√	√	–
	$f_{CLK}/2^{12}$	–	–	√	√
	$f_{CLK}/2^{14}$	–	–	√	√

<R> **Note** The margin is within 5 %.

- Remarks 1.**  $f_{CLK}$ : CPU/peripheral hardware clock frequency  
 2. For details of asignal of  $f_{CLK}/2^m$  selected with the TPSm register, see 6.5.1 Count clock ( $f_{TCLK}$ ).

**(3) Timer mode register mn (TMRmn)**

The TMRmn register sets an operation mode of channel n. This register is used to select the operation clock ( $f_{MCK}$ ), select the count clock, select the master/slave, select the 16 or 8-bit timer (only for channels 1 and 3), specify the start trigger and capture trigger, select the valid edge of the timer input, and specify the operation mode (interval, capture, event counter, one-count, or capture and one-count).

Rewriting the TMRmn register is prohibited when the register is in operation (when  $TE_{mn} = 1$ ). However, bits 7 and 6 ( $CIS_{mn1}$ ,  $CIS_{mn0}$ ) can be rewritten even while the register is operating with some functions (when  $TE_{mn} = 1$ ) (for details, see **6.7 Independent Channel Operation Function of Timer Array Unit** and **6.8 Simultaneous Channel Operation Function of Timer Array Unit**).

The TMRmn register can be set by a 16-bit memory manipulation instruction.

Reset signal generation clears this register to 0000H.

&lt;R&gt;

**Caution** The bits mounted depend on the channels in the bit 11 of TMRmn register.

**TMRm2, TMRm4, TMRm6: MASTERmn bit (n = 2, 4, 6)**

**TMRm1, TMRm3: SPLITmn bit (n = 1, 3)**

**TMRm0, TMRm5, TMRm7: Fixed to 0**

<R>

**Figure 6-8. Format of Timer Mode Register mn (TMRmn) (1/4)**

Address: F0190H, F0191H (TMR00) to F019EH, F019FH (TMR07) After reset: 0000H R/W  
 F01D0H, F01D1H (TMR10) to F01DEH, F01DFH (TMR17)

Symbol	15	14	13	12	11	10	9	8	7	6	5	4	3	2	1	0
TMRmn (n = 2, 4, 6)	CKS mn1	CKS mn0	0	CCS mn	MAST ERmn	STS mn2	STS mn1	STS mn0	CIS mn1	CIS mn0	0	0	MD mn3	MD mn2	MD mn1	MD mn0

Symbol	15	14	13	12	11	10	9	8	7	6	5	4	3	2	1	0
TMRmn (n = 1, 3)	CKS mn1	CKS mn0	0	CCS mn	SPLIT mn	STS mn2	STS mn1	STS mn0	CIS mn1	CIS mn0	0	0	MD mn3	MD mn2	MD mn1	MD mn0

Symbol	15	14	13	12	11	10	9	8	7	6	5	4	3	2	1	0
TMRmn (n = 0, 5, 7)	CKS mn1	CKS mn0	0	CCS mn	0	STS mn2	STS mn1	STS mn0	CIS mn1	CIS mn0	0	0	MD mn3	MD mn2	MD mn1	MD mn0

CKS mn1	CKS mn0	Selection of operation clock ( $f_{MCK}$ ) of channel n
0	0	Operation clock CKm0 set by timer clock select register m (TPSm)
0	1	Operation clock CKm2 set by timer clock select register m (TPSm)
1	0	Operation clock CKm1 set by timer clock select register m (TPSm)
1	1	Operation clock CKm3 set by timer clock select register m (TPSm)
Operation clock ( $f_{MCK}$ ) is used by the edge detector. A count clock ( $f_{TCLK}$ ) and a sampling clock are generated depending on the setting of the CCSmn bit.		
The operation clocks CKm2 and CKm3 can only be selected for channels 1 and 3.		

CCS mn	Selection of count clock ( $f_{TCLK}$ ) of channel n
0	Operation clock ( $f_{MCK}$ ) specified by the CKSmn0 and CKSmn1 bits
1	Valid edge of input signal input from the TImn pin
Count clock ( $f_{TCLK}$ ) is used for the timer/counter, output controller, and interrupt controller.	

- Cautions**
1. Be sure to clear bits 13, 5, and 4 to “0”.
  2. The timer array unit must be stopped (TTm = 00FFH) if the clock selected for  $f_{CLK}$  is changed (by changing the value of the system clock control register (CKC)), even if the operating clock specified by using the CKSmn0 and CKSmn1 bits ( $f_{MCK}$ ) or the valid edge of the signal input from the TImn pin is selected as the count clock ( $f_{TCLK}$ ).

**Remark** m: Unit number (m = 0, 1), n: Channel number (n = 0 to 7)

<R>

**Figure 6-8. Format of Timer Mode Register mn (TMRmn) (2/4)**

Address: F0190H, F0191H (TMR00) to F019EH, F019FH (TMR07) After reset: 0000H R/W  
 F01D0H, F01D1H (TMR10) to F01DEH, F01DFH (TMR17)

Symbol	15	14	13	12	11	10	9	8	7	6	5	4	3	2	1	0
TMRmn (n = 2, 4, 6)	CKS mn1	CKS mn0	0	CCS mn	MAST ERmn	STS mn2	STS mn1	STS mn0	CIS mn1	CIS mn0	0	0	MD mn3	MD mn2	MD mn1	MD mn0

Symbol	15	14	13	12	11	10	9	8	7	6	5	4	3	2	1	0
TMRmn (n = 1, 3)	CKS mn1	CKS mn0	0	CCS mn	SPLIT mn	STS mn2	STS mn1	STS mn0	CIS mn1	CIS mn0	0	0	MD mn3	MD mn2	MD mn1	MD mn0

Symbol	15	14	13	12	11	10	9	8	7	6	5	4	3	2	1	0
TMRmn (n = 0, 5, 7)	CKS mn1	CKS mn0	0	CCS mn	0	STS mn2	STS mn1	STS mn0	CIS mn1	CIS mn0	0	0	MD mn3	MD mn2	MD mn1	MD mn0

(Bit 11 of TMRmn (n = 2, 4, 6))

MAS TER mn	Selection between using channel n independently or simultaneously with another channel(as a slave or master)	
0	Operates in independent channel operation function or as slave channel in simultaneous channel operation function.	
1	Operates as master channel in simultaneous channel operation function.	

Only the channel 2, 4, 6 can be set as a master channel (MASTERmn = 1).  
 Be sure to use channel 0, 5, 7 are fixed to 0 (Regardless of the bit setting, channel 0 operates as master, because it is the highest channel).  
 Clear the MASTERmn bit to 0 for a channel that is used with the independent channel operation function.

<R>

(Bit 11 of TMRmn (n = 1, 3))

SPLI Tmn	Selection of 8 or 16-bit timer operation for channels 1 and 3	
0	Operates as 16-bit timer. (Operates in independent channel operation function or as slave channel in simultaneous channel operation function.)	
1	Operates as 8-bit timer.	

STS mn2	STS mn1	STS mn0	Setting of start trigger or capture trigger of channel n
0	0	0	Only software trigger start is valid (other trigger sources are unselected).
0	0	1	Valid edge of the TImn pin input is used as both the start trigger and capture trigger.
0	1	0	Both the edges of the TImn pin input are used as a start trigger and a capture trigger.
1	0	0	Interrupt signal of the master channel is used (when the channel is used as a slave channel with the simultaneous channel operation function).
Other than above			Setting prohibited

**Remark** m: Unit number (m = 0, 1), n: Channel number (n = 0 to 7)



<R>

**Figure 6-8. Format of Timer Mode Register mn (TMRmn) (3/4)**

Address: F0190H, F0191H (TMR00) to F019EH, F019FH (TMR07) After reset: 0000H R/W  
 F01D0H, F01D1H (TMR10) to F01DEH, F01DFH (TMR17)

Symbol	15	14	13	12	11	10	9	8	7	6	5	4	3	2	1	0
TMRmn (n = 2, 4, 6)	CKS mn1	CKS mn0	0	CCS mn	MAST ERmn	STS mn2	STS mn1	STS mn0	CIS mn1	CIS mn0	0	0	MD mn3	MD mn2	MD mn1	MD mn0

Symbol	15	14	13	12	11	10	9	8	7	6	5	4	3	2	1	0
TMRmn (n = 1, 3)	CKS mn1	CKS mn0	0	CCS mn	SPLIT mn	STS mn2	STS mn1	STS mn0	CIS mn1	CIS mn0	0	0	MD mn3	MD mn2	MD mn1	MD mn0

Symbol	15	14	13	12	11	10	9	8	7	6	5	4	3	2	1	0
TMRmn (n = 0, 5, 7)	CKS mn1	CKS mn0	0	CCS mn	0	STS mn2	STS mn1	STS mn0	CIS mn1	CIS mn0	0	0	MD mn3	MD mn2	MD mn1	MD mn0

CIS mn1	CIS mn0	Selection of TImn pin input valid edge
0	0	Falling edge
0	1	Rising edge
1	0	Both edges (when low-level width is measured) Start trigger: Falling edge, Capture trigger: Rising edge
1	1	Both edges (when high-level width is measured) Start trigger: Rising edge, Capture trigger: Falling edge
If both the edges are specified when the value of the STSmn2 to STSmn0 bits is other than 010B, set the CISmn1 to CISmn0 bits to 10B.		

MD mn3	MD mn2	MD mn1	MD mn0	Operation mode of channel n	Corresponding function	Count operation of TCR
0	0	0	1/0	Interval timer mode	Interval timer / Square wave output / Divider function / PWM output (master)	Counting down
0	1	0	1/0	Capture mode	Input pulse interval measurement	Counting up
0	1	1	0	Event counter mode	External event counter	Counting down
1	0	0	1/0	One-count mode	Delay counter / One-shot pulse output / PWM output (slave)	Counting down
1	1	0	0	Capture & one-count mode	Measurement of high-/low-level width of input signal	Counting up
Other than above				Setting prohibited		
The operation of the MDmn0 bit varies depending on each operation mode (see table below).						

**Remark** m: Unit number (m = 0, 1), n: Channel number (n = 0 to 7)

<R>

**Figure 6-8. Format of Timer Mode Register mn (TMRmn) (4/4)**

Address: F0190H, F0191H (TMR00) to F019EH, F019FH (TMR07) After reset: 0000H R/W  
 F01D0H, F01D1H (TMR10) to F01DEH, F01DFH (TMR17)

Symbol	15	14	13	12	11	10	9	8	7	6	5	4	3	2	1	0
TMRmn (n = 2, 4, 6)	CKS mn1	CKS mn0	0	CCS mn	MAST ERmn	STS mn2	STS mn1	STS mn0	CIS mn1	CIS mn0	0	0	MD mn3	MD mn2	MD mn1	MD mn0

Symbol	15	14	13	12	11	10	9	8	7	6	5	4	3	2	1	0
TMRmn (n = 1, 3)	CKS mn1	CKS mn0	0	CCS mn	SPLIT mn	STS mn2	STS mn1	STS mn0	CIS mn1	CIS mn0	0	0	MD mn3	MD mn2	MD mn1	MD mn0

Symbol	15	14	13	12	11	10	9	8	7	6	5	4	3	2	1	0
TMRmn (n = 0, 5, 7)	CKS mn1	CKS mn0	0	CCS mn	0	STS mn2	STS mn1	STS mn0	CIS mn1	CIS mn0	0	0	MD mn3	MD mn2	MD mn1	MD mn0

Operation mode (Value set by the MDmn3 to MDmn1 bits (see table above))	MD mn0	Setting of starting counting and interrupt
<ul style="list-style-type: none"> <li>Interval timer mode (0, 0, 0)</li> <li>Capture mode (0, 1, 0)</li> </ul>	0	Timer interrupt is not generated when counting is started (timer output does not change, either).
	1	Timer interrupt is generated when counting is started (timer output also changes).
<ul style="list-style-type: none"> <li>Event counter mode (0, 1, 1)</li> </ul>	0	Timer interrupt is not generated when counting is started (timer output does not change, either).
<ul style="list-style-type: none"> <li>One-count mode <sup>Note 1</sup> (1, 0, 0)</li> </ul>	0	Start trigger is invalid during counting operation. At that time, interrupt is not generated, either.
	1	Start trigger is valid during counting operation <sup>Note 2</sup> . At that time, interrupt is also generated.
<ul style="list-style-type: none"> <li>Capture &amp; one-count mode (1, 1, 0)</li> </ul>	0	Timer interrupt is not generated when counting is started (timer output does not change, either). Start trigger is invalid during counting operation. At that time interrupt is not generated, either.
Other than above		Setting prohibited

**Notes 1.** In one-count mode, interrupt output (INTTMmn) when starting a count operation and TOMn output are not controlled.

<R>

**2.** If the start trigger (TSmn = 1) is issued during operation, the counter is initialized, an interrupt is generated, **and** recounting is started.

**Remark** m: Unit number (m = 0, 1), n: Channel number (n = 0 to 7)

**(4) Timer status register mn (TSRmn)**

The TSRmn register indicates the overflow status of the counter of channel n.

The TSRmn register is valid only in the capture mode (MDmn3 to MDmn1 = 010B) and capture & one-count mode (MDmn3 to MDmn1 = 110B). See Table 6-5 for the operation of the OVF bit in each operation mode and set/clear conditions.

The TSRmn register can be read by a 16-bit memory manipulation instruction.

The lower 8 bits of the TSRmn register can be set with an 8-bit memory manipulation instruction with TSRmnL.

Reset signal generation clears this register to 0000H.

**Figure 6-9. Format of Timer Status Register mn (TSRmn)**

Address: F01A0H, F01A1H (TSR00) to F01AEH, F01AFH (TSR07), After reset: 0000H R  
 F01E0H, F01E1H (TSR10) to F01EEH, F01EFH (TSR17)

Symbol	15	14	13	12	11	10	9	8	7	6	5	4	3	2	1	0
TSRmn	0	0	0	0	0	0	0	0	0	0	0	0	0	0	0	OVF

OVF	Counter overflow status of channel n
0	Overflow does not occur.
1	Overflow occurs.
When OVF = 1, this flag is cleared (OVF = 0) when the next value is captured without overflow.	

**Remark** m: Unit number (m = 0, 1), n: Channel number (n = 0 to 7)

**Table 6-5. OVF Bit Operation and Set/Clear Conditions in Each Operation Mode**

Timer operation mode	OVF bit	Set/clear conditions
• Capture mode	clear	When no overflow has occurred upon capturing
• Capture & one-count mode	set	When an overflow has occurred upon capturing
• Interval timer mode	clear	-
• Event counter mode	set	
• One-count mode		

**Remark** The OVF bit does not change immediately after the counter has overflowed, but changes upon the subsequent capture.

**(5) Timer channel enable status register m (TE<sub>m</sub>)**

The TE<sub>m</sub> register is used to enable or stop the timer operation of each channel.

<R> Each bit of the TE<sub>m</sub> register corresponds to each bit of the timer channel start register m (T<sub>Sm</sub>) and the timer channel stop register m (T<sub>Tm</sub>). When a bit of the T<sub>Sm</sub> register is set to 1, the corresponding bit of this register is set to 1. When a bit of the T<sub>Tm</sub> register is set to 1, the corresponding bit of this register is cleared to 0.

The TE<sub>m</sub> register can be read by a 16-bit memory manipulation instruction.

The lower 8 bits of the TE<sub>m</sub> register can be set with a 1-bit or 8-bit memory manipulation instruction with TE<sub>m</sub>L.

Reset signal generation clears this register to 0000H.

**Figure 6-10. Format of Timer Channel Enable Status register m (TE<sub>m</sub>)**

Address: F01B0H, F01B1H (TE<sub>0</sub>), F01F0H, F01F1H (TE<sub>1</sub>) After reset: 0000H R

Symbol	15	14	13	12	11	10	9	8	7	6	5	4	3	2	1	0
TE <sub>m</sub>	0	0	0	0	TEH <sub>m</sub> 3	0	TEH <sub>m</sub> 1	0	TE <sub>m</sub> 7	TE <sub>m</sub> 6	TE <sub>m</sub> 5	TE <sub>m</sub> 4	TE <sub>m</sub> 3	TE <sub>m</sub> 2	TE <sub>m</sub> 1	TE <sub>m</sub> 0

TEH 03	Indication of whether operation of the higher 8-bit timer is enabled or stopped when channel 3 is in the 8-bit timer mode
0	Operation is stopped.
1	Operation is enabled.

TEH 01	Indication of whether operation of the higher 8-bit timer is enabled or stopped when channel 1 is in the 8-bit timer mode
0	Operation is stopped.
1	Operation is enabled.

TE <sub>m</sub> <sub>n</sub>	Indication of operation enable/stop status of channel n
0	Operation is stopped.
1	Operation is enabled.
This bit displays whether operation of the lower 8-bit timer for TE <sub>m</sub> 1 and TE <sub>m</sub> 3 is enabled or stopped when channel 1 or 3 is in the 8-bit timer mode.	

**Remark** m: Unit number (m = 0, 1), n: Channel number (n = 0 to 7)

**(6) Timer channel start register m (TSm)**

<R> The TSm register is a trigger register that is used to initialize timer count register mn (TCRmn) and start the counting operation of each channel.

When a bit of this register is set to 1, the corresponding bit of timer channel enable status register m (TEm) is set to 1. The TSmn, TSHm1, TSHm3 bits are immediately cleared when operation is enabled (TEmn, TEHm1, TEHm3 = 1), because they are trigger bits.

The TSm register can be set by a 16-bit memory manipulation instruction.

The lower 8 bits of the TSm register can be set with a 1-bit or 8-bit memory manipulation instruction with TSmL.

Reset signal generation clears this register to 0000H.

**Figure 6-11. Format of Timer Channel Start register m (TSm)**

Address: F01B2H, F01B3H (TS0), F01F2H, F01F3H (TS1) After reset: 0000H R/W

Symbol	15	14	13	12	11	10	9	8	7	6	5	4	3	2	1	0
TSm	0	0	0	0	TSHm3	0	TSHm1	0	TSm7	TSm6	TSm5	TSm4	TSm3	TSm2	TSm1	TSm0

TSHm3	Trigger to enable operation (start operation) of the higher 8-bit timer when channel 3 is in the 8-bit timer mode
0	No trigger operation
1	The TEHm3 bit is set to 1 and the count operation becomes enabled. The TCRm3 register count operation start in the interval timer mode in the count operation enabled state (see Table 6-6 in <b>6.5.2 Start timing of counter</b> ).

TSHm1	Trigger to enable operation (start operation) of the higher 8-bit timer when channel 1 is in the 8-bit timer mode
0	No trigger operation
1	The TEHm1 bit is set to 1 and the count operation becomes enabled. The TCRm1 register count operation start in the interval timer mode in the count operation enabled state (see Table 6-6 in <b>6.5.2 Start timing of counter</b> ).

TSmn	Operation enable (start) trigger of channel n
0	No trigger operation
1	The TEMn bit is set to 1 and the count operation becomes enabled. The TCRmn register count operation start in the count operation enabled state varies depending on each operation mode (see Table 6-6 in <b>6.5.2 Start timing of counter</b> ). This bit is the trigger to enable operation (start operation) of the lower 8-bit timer for TSm1 and TSm3 when channel 1 or 3 is in the 8-bit timer mode.

- Cautions**
1. Be sure to clear bits 15 to 12, 10, 8 to "0"
  2. When switching from a function that does not use TImn pin input to one that does, the following wait period is required from when timer mode register mn (TMRmn) is set until the TSmn (TSHm1, TSHm3) bit is set to 1.  
 When the TImn pin noise filter is enabled (TNFEN = 1): Four cycles of the operation clock (fMCK)  
 When the TImn pin noise filter is disabled (TNFEN = 0): Two cycles of the operation clock (fMCK)

- Remarks**
1. When the TSm register is read, 0 is always read.
  2. m: Unit number (m = 0, 1), n: Channel number (n = 0 to 7)

**(7) Timer channel stop register m (TTm)**

The TTm register is a trigger register that is used to stop the counting operation of each channel.  
 When a bit of this register is set to 1, the corresponding bit of timer channel enable status register m (TEm) is cleared to 0. The TTmn, TTHm1, TTHm3 bits are immediately cleared when operation is stopped (TEmn, TTHm1, TTHm3 = 0), because they are trigger bits.  
 The TTm register can be set by a 16-bit memory manipulation instruction.  
 The lower 8 bits of the TTm register can be set with a 1-bit or 8-bit memory manipulation instruction with TTmL.  
 Reset signal generation clears this register to 0000H.

**Figure 6-12. Format of Timer Channel Stop register m (TTm)**

Address: F01B4H, F01B5H After reset: 0000H R/W

Symbol	15	14	13	12	11	10	9	8	7	6	5	4	3	2	1	0
TTm	0	0	0	0	TTHm 3	0	TTHm 1	0	TTm 7	TTm 6	TTm 5	TTm 4	TTm 3	TTm 2	TTm 1	TTm 0

TTHm3	Trigger to stop operation of the higher 8-bit timer when channel 3 is in the 8-bit timer mode
0	No trigger operation
1	Operation is stopped (stop trigger is generated).

TTHm1	Trigger to stop operation of the higher 8-bit timer when channel 1 is in the 8-bit timer mode
0	No trigger operation
1	Operation is stopped (stop trigger is generated).

TTm n	Operation stop trigger of channel n
0	No trigger operation
1	Operation is stopped (stop trigger is generated). This bit is the trigger to stop operation of the lower 8-bit timer for TTm1 and TTm3 when channel 1 or 3 is in the 8-bit timer mode.

**Caution** Be sure to clear bits 15 to 12, 10, 8 of the TTm register to “0”.

- Remarks 1.** When the TTm register is read, 0 is always read.  
**2.** m: Unit number (m = 0, 1), n: Channel number (n = 0 to 7)

**(8) Timer input select register 0 (TIS0)**

The TIS0 register is used to select the channel 5 of unit 0 timer input..

The TIS0 register can be set by an 8-bit memory manipulation instruction.

Reset signal generation clears this register to 00H.

**Figure 6-13. Format of Timer Input Select register 0 (TIS0)**

Address: F0074H    After reset: 00H    R/W

Symbol	7	6	5	4	3	2	1	0
TIS0	0	0	0	0	0	TIS02	TIS01	TIS00

TIS02	TIS01	TIS00	Selection of timer input used with channel 5
0	0	0	Input signal of timer input pin (TI05)
0	0	1	
0	1	0	
0	1	1	
1	0	0	Low-speed on-chip oscillator clock ( $f_{IL}$ )
1	0	1	Subsystem clock ( $f_{SUB}$ )
Other than above			Setting prohibited

**(9) Timer output enable register m (TOEm)**

The TOEm register is used to enable or disable timer output of each channel.

Channel n for which timer output has been enabled becomes unable to rewrite the value of the TOMn bit of timer output register m (TOM) described later by software, and the value reflecting the setting of the timer output function through the count operation is output from the timer output pin (TOMn).

The TOEm register can be set by a 16-bit memory manipulation instruction.

The lower 8 bits of the TOEm register can be set with a 1-bit or 8-bit memory manipulation instruction with TOEmL. Reset signal generation clears this register to 0000H.

**Figure 6-14. Format of Timer Output Enable register m (TOEm)**

Address: F01BAH, F01BBH (TOE0), F01FAH, F01FBH (TOE1) After reset: 0000H R/W

Symbol	15	14	13	12	11	10	9	8	7	6	5	4	3	2	1	0
TOEm	0	0	0	0	0	0	0	0	TOE m7	TOE m6	TOE m5	TOE m4	TOE m3	TOE m2	TOE m1	TOE m0

TOE mn	Timer output enable/disable of channel n
0	The TOMn operation stopped by count operation (timer channel output bit). Writing to the TOMn bit is enabled. The TOMn pin functions as data output, and it outputs the level set to the TOMn bit. The output level of the TOMn pin can be manipulated by software.
1	The TOMn operation enabled by count operation (timer channel output bit). Writing to the TOMn bit is disabled (writing is ignored). The TOMn pin functions as timer output, and the TOEmn bit is set or reset depending on the timer operation. The TOMn pin outputs the square-wave or PWM depending on the timer operation.

**Caution** Be sure to clear bits 15 to 8 to “0”.

**Remark** m: Unit number (m = 0, 1), n: Channel number (n = 0 to 7)



**(10) Timer output register m (TOM)**

The TOM register is a buffer register of timer output of each channel.

The value of each bit in this register is output from the timer output pin (TOMn) of each channel.

The TOMn bit of this register can be rewritten by software only when timer output is disabled (TOEmn = 0). When timer output is enabled (TOEmn = 1), rewriting this register by software is ignored, and the value is changed only by the timer operation.

To use the P00/TI00, P01/TO00, P16/TI01/TO01, P17/TI02/TO02, P31/TI03/TO03, P42/TI04/TO04, P46/TI05/TO05, P102/TI06/TO06, P145/TI07/TO07, P64/TI10/TO10, P65/TI11/TO11, P66/TI12/TO12, P67/TI13/TO13, P103/TI14/TO14, P104/TI15/TO15, P105/TI16/TO16, or P106/TI17/TO17 pin as a port function pin, set the corresponding TOMn bit to "0".

The TOM register can be set by a 16-bit memory manipulation instruction.

The lower 8 bits of the TOM register can be set with an 8-bit memory manipulation instruction with TOML.

Reset signal generation clears this register to 0000H.

**Figure 6-15. Format of Timer Output register m (TOM)**

Address: F01B8H, F01B9H (TO0), F01F8H, F01F9H (TO1) After reset: 0000H R/W

Symbol	15	14	13	12	11	10	9	8	7	6	5	4	3	2	1	0
TOM	0	0	0	0	0	0	0	0	TOM 7	TOM 6	TOM 5	TOM 4	TOM 3	TOM 2	TOM 1	TOM 0

TOM n	Timer output of channel n
0	Timer output value is "0".
1	Timer output value is "1".

**Caution** Be sure to clear bits 15 to 8 to "0".

**Remark** m: Unit number (m = 0, 1), n: Channel number (n = 0 to 7)

**(11) Timer output level register m (TOLm)**

The TOLm register is a register that controls the timer output level of each channel.

The setting of the inverted output of channel n by this register is reflected at the timing of set or reset of the timer output signal while the timer output is enabled ( $TOEmn = 1$ ) in the Slave channel output mode ( $TOMmn = 1$ ). In the master channel output mode ( $TOMmn = 0$ ), this register setting is invalid.

The TOLm register can be set by a 16-bit memory manipulation instruction.

The lower 8 bits of the TOLm register can be set with an 8-bit memory manipulation instruction with TOLmL.

Reset signal generation clears this register to 0000H.

**Figure 6-16. Format of Timer Output Level register m (TOLm)**

Address: F01BCH, F01BDH (TOL0), F01FCH, F01FDH (TOL1) After reset: 0000H R/W

Symbol	15	14	13	12	11	10	9	8	7	6	5	4	3	2	1	0
TOLm	0	0	0	0	0	0	0	0	TOL m7	TOL m6	TOL m5	TOL m4	TOL m3	TOL m2	TOL m1	0

TOL mn	Control of timer output level of channel n														
0	Positive logic output (active-high)														
1	Negative logic output (active-low)														

**Caution** Be sure to clear bits 15 to 8, and 0 to “0”.

- Remarks 1.** If the value of this register is rewritten during timer operation, the timer output logic is inverted when the timer output signal changes next, instead of immediately after the register value is rewritten.
- 2.** m: Unit number (m = 0, 1), n: Channel number (n = 0 to 7)

**(12) Timer output mode register m (TOMm)**

The TOMm register is used to control the timer output mode of each channel.

When a channel is used for the independent channel operation function, set the corresponding bit of the channel to be used to 0.

When a channel is used for the simultaneous channel operation function (PWM output, one-shot pulse output, or multiple PWM output), set the corresponding bit of the master channel to 0 and the corresponding bit of the slave channel to 1.

The setting of each channel n by this register is reflected at the timing when the timer output signal is set or reset while the timer output is enabled (TOEmn = 1).

The TOMm register can be set by a 16-bit memory manipulation instruction.

The lower 8 bits of the TOMm register can be set with an 8-bit memory manipulation instruction with TOMmL.

Reset signal generation clears this register to 0000H.

**Figure 6-17. Format of Timer Output Mode register m (TOMm)**

Address: F01BEH, F01BFH (TOM0), F01FEH, F01FFH (TOM1) After reset: 0000H R/W

Symbol	15	14	13	12	11	10	9	8	7	6	5	4	3	2	1	0
TOMm	0	0	0	0	0	0	0	0	TOM m7	TOM m6	TOM m5	TOM m4	TOM m3	TOM m2	TOM m1	0

TOM mn	Control of timer output mode of channel n
0	Master channel output mode (to produce toggle output by timer interrupt request signal (INTTMmn))
1	Slave channel output mode (output is set by the timer interrupt request signal (INTTMmn) of the master channel, and reset by the timer interrupt request signal (INTTM0p) of the slave channel)

**Caution** Be sure to clear bits 15 to 8, and 0 to “0”.

**Remark** m: Unit number (m = 0, 1)

n: Channel number

n = 0 to 7 (n = 0, 2, 4, 6 for master channel)

p: Slave channel number

n < p ≤ 7

(For details of the relation between the master channel and slave channel, refer to **6.4.1 Basic rules of simultaneous channel operation function.**)

**(13) Input switch control register (ISC)**

The ISC1 and ISC0 bits of the ISC register are used to implement LIN-bus communication operation by using channel 7 in association with the serial array unit. When the ISC1 bit is set to 1, the input signal of the serial data input pin (RxD2) is selected as a timer input signal.

The ISC register can be set by a 1-bit or 8-bit memory manipulation instruction.

Reset signal generation clears this register to 00H.

**Figure 6-18. Format of Input Switch Control Register (ISC)**

Address: F0073H After reset: 00H R/W

Symbol	7	6	5	4	3	2	1	0
ISC	0	0	0	0	0	0	ISC1	ISC0

<R>

ISC1	Switching channel 7 input of timer array unit
0	30, 32, 36, 40, 44, 48, 52, 64, 80, 100, and 128-pin products: Uses the input signal of the TI07 pin as a timer input (normal operation). 20, 24, 25-pin products: Do not use a timer input signal for channel 7.
1	Input signal of the RxD2 pin is used as timer input (detects the wakeup signal and measures the low width of the sync break field and the pulse width of the sync field). Setting is prohibited in the 20, 24, and 25-pin products.

ISC0	Switching external interrupt (INTP0) input
0	Uses the input signal of the INTP0 pin as an external interrupt (normal operation).
1	Uses the input signal of the RxD2 pin as an external interrupt (wakeup signal detection).

**Caution** Be sure to clear bits 7 to 2 to “0”.

**Remark** When the LIN-bus communication function is used, select the input signal of the RxD2 pin by setting ISC1 to 1.

**(14) Noise filter enable registers 1, 2 (NFEN1, NFEN2)**

The NFEN1, NFEN2 registers is used to set whether the noise filter can be used for the timer input signal to each channel.

Enable the noise filter by setting the corresponding bits to 1 on the pins in need of noise removal.

When the noise filter is ON, match detection and synchronization of the 2 clocks is performed with the CPU/peripheral hardware clock ( $f_{MCK}$ ). When the noise filter is OFF, only synchronization is performed with the CPU/peripheral hardware clock ( $f_{MCK}$ )<sup>Note</sup>.

The NFEN1, NFEN2 registers can be set by a 1-bit or 8-bit memory manipulation instruction.

Reset signal generation clears this register to 00H.

**Note** For details, see **6.5.1 (2) When valid edge of input signal input from the TImn pin is selected (CCSmn = 1)** and **6.5.2 Start timing of counter**.

Figure 6-19. Format of Noise Filter Enable Registers 1, 2 (NFEN1, NFEN2) (1/2)

Address: F0071H After reset: 00H R/W

Symbol	7	6	5	4	3	2	1	0
NFEN1	TNFEN07	TNFEN06	TNFEN05	TNFEN04	TNFEN03	TNFEN02	TNFEN01	TNFEN00

Address: F0072H After reset: 00H R/W

Symbol	7	6	5	4	3	2	1	0
NFEN2	TNFEN17	TNFEN16	TNFEN15	TNFEN14	TNFEN13	TNFEN12	TNFEN11	TNFEN10

TNFEN07	Enable/disable using noise filter of TI07/TO07/P145 pin or RxD2/P14 pin input signal <sup>Note</sup>
0	Noise filter OFF
1	Noise filter ON

TNFEN06	Enable/disable using noise filter of TI06/TO06/P102 pin input signal
0	Noise filter OFF
1	Noise filter ON

TNFEN05	Enable/disable using noise filter of TI05/TO05/P46 pin input signal
0	Noise filter OFF
1	Noise filter ON

TNFEN04	Enable/disable using noise filter of TI04/TO04/P04 pin input signal
0	Noise filter OFF
1	Noise filter ON

TNFEN03	Enable/disable using noise filter of TI03/TO03/P31 pin input signal
0	Noise filter OFF
1	Noise filter ON

TNFEN02	Enable/disable using noise filter of TI02/TO02/P17 pin input signal
0	Noise filter OFF
1	Noise filter ON

TNFEN01	Enable/disable using noise filter of TI01/P01/P16 pin input signal
0	Noise filter OFF
1	Noise filter ON

TNFEN00	Enable/disable using noise filter of TI00/P00 pin input signal
0	Noise filter OFF
1	Noise filter ON

**Note** The applicable pin can be switched by setting the ISC1 bit of the ISC register.

ISC1 = 0: Whether or not to use the noise filter of the TI07 pin can be selected.

ISC1 = 1: Whether or not to use the noise filter of the RxD2 pin can be selected.

**Remark** The presence or absence of timer I/O pins of channel 0 to 7 depends on the product. See **Table 6-2 Timer I/O Pins provided in Each Product** for details.

**Figure 6-19. Format of Noise Filter Enable Registers 1, 2 (NFEN1, NFEN2) (2/2)**

Address: F0071H    After reset: 00H    R/W

Symbol	7	6	5	4	3	2	1	0
NFEN1	TNFEN07	TNFEN06	TNFEN05	TNFEN04	TNFEN03	TNFEN02	TNFEN01	TNFEN00

Address: F0072H    After reset: 00H    R/W

Symbol	7	6	5	4	3	2	1	0
NFEN2	TNFEN17	TNFEN16	TNFEN15	TNFEN14	TNFEN13	TNFEN12	TNFEN11	TNFEN10

TNFEN17	Enable/disable using noise filter of T117/TO17/P106 pin input signal
0	Noise filter OFF
1	Noise filter ON

TNFEN16	Enable/disable using noise filter of T116/TO16/P105 pin input signal
0	Noise filter OFF
1	Noise filter ON

TNFEN15	Enable/disable using noise filter of T115/TO15/P104 pin input signal
0	Noise filter OFF
1	Noise filter ON

TNFEN14	Enable/disable using noise filter of T114/TO14/P103 pin input signal
0	Noise filter OFF
1	Noise filter ON

TNFEN13	Enable/disable using noise filter of T113/TO13/P67 pin input signal
0	Noise filter OFF
1	Noise filter ON

TNFEN12	Enable/disable using noise filter of T112/TO12/P66 pin input signal
0	Noise filter OFF
1	Noise filter ON

TNFEN11	Enable/disable using noise filter of T111/P11/P65 pin input signal
0	Noise filter OFF
1	Noise filter ON

TNFEN10	Enable/disable using noise filter of T100/P64 pin input signal
0	Noise filter OFF
1	Noise filter ON

**Remark** The presence or absence of timer I/O pins of channel 0 to 7 depends on the product. See **Table 6-2 Timer I/O Pins provided in Each Product** for details.

**(15) Port mode registers 0, 1, 3, 4, 6, 10, 14 (PM0, PM1, PM3, PM4, PM6, PM10, PM14)**

These registers set input/output of ports 0, 1, 3, 4, 6, 10, 14 in 1-bit units.

The presence or absence of timer I/O pins depends on the product. When using the timer array unit, set the following port mode registers according to the product used.

20, 24, 25, 30, 32, 36, and 40-pin products: PM0, PM1, PM3

44, 48, 52, and 64-pin products: PM0, PM1, PM3, PM4

80-pin products: PM0, PM1, PM3, PM4, PM6

100 and 128-pin products: PM0, PM1, PM3, PM4, PM6, PM10, PM14

When using the ports (such as P01/TO00 and P17/TO02/TI02) to be shared with the timer output pin for timer output, set the port mode register (PMxx) bit and port register (Pxx) bit corresponding to each port to 0.

Example: When using P17/TO02/TI02 for timer output

Set the PM17 bit of port mode register 1 to 0.

Set the P17 bit of port register 1 to 0.

When using the ports (such as P00/TI00 and P17/TO02/TI02) to be shared with the timer input pin for timer input, set the port mode register (PMxx) bit corresponding to each port to 1. At this time, the port register (Pxx) bit may be 0 or 1.

Example: When using P17/TO02/TI02 for timer input

Set the PM17 bit of port mode register 1 to 1.

Set the P17 bit of port register 1 to 0 or 1.

The PM0, PM1, PM3, PM4, PM6, PM10, PM14 registers can be set by a 1-bit or 8-bit memory manipulation instruction.

Reset signal generation sets these registers to FFH.

<R> **Remark** In the 20- to 30-pin products, TI00 (P00) and TO00 (P01) pins alternate analog input pins. When using the timer I/O function, the corresponding bit of the PMC0 register for switching digital I/O or analog input is sure to set to "0".



**Figure 6-20. Format of Port Mode Registers 0, 1, 3, 4, 6, 10, 14 (PM0, PM1, PM3, PM4, PM6, PM10, PM14)  
(128-pin products)**

Address: FFF20H After reset: FFH R/W

Symbol	7	6	5	4	3	2	1	0
PM0	1	PM06	PM05	PM04	PM03	PM02	PM01	PM00

Address: FFF21H After reset: FFH R/W

Symbol	7	6	5	4	3	2	1	0
PM1	PM17	PM16	PM15	PM14	PM13	PM12	PM11	PM10

Address: FFF23H After reset: FFH R/W

Symbol	7	6	5	4	3	2	1	0
PM3	1	1	1	1	1	1	PM31	PM30

Address: FFF24H After reset: FFH R/W

Symbol	7	6	5	4	3	2	1	0
PM4	1	1	1	1	PM43	PM42	PM41	PM40

Address: FFF26H After reset: FFH R/W

Symbol	7	6	5	4	3	2	1	0
PM6	PM67	PM66	PM65	PM64	PM63	PM62	PM61	PM60

Address: FFF2AH After reset: FFH R/W

Symbol	7	6	5	4	3	2	1	0
PM10	1	PM106	PM105	PM104	PM103	PM102	PM101	PM100

Address: FFF2EH After reset: FFH R/W

Symbol	7	6	5	4	3	2	1	0
PM14	PM147	PM146	PM145	PM144	PM143	PM142	PM141	PM140

PMmn	Pmn pin I/O mode selection (m = 0, 1, 3, 4, 6, 10, 14; n = 0 to 7)
0	Output mode (output buffer on)
1	Input mode (output buffer off)

**Remark** The figure shown above presents the format of port mode registers 0, 1, 3, 4, 6, 10, and 14 of the 128-pin products. The format of the port mode register of other products, see **4.3 (1) Port mode registers (PMxx)**.

## 6.4 Basic Rules of Timer Array Unit

### 6.4.1 Basic rules of simultaneous channel operation function

When simultaneously using multiple channels, namely, a combination of a master channel (a reference timer mainly counting the cycle) and slave channels (timers operating according to the master channel), the following rules apply.

- (1) Only an even channel (channel 0, 2, 4, etc.) can be set as a master channel.
- (2) Any channel, except channel 0, can be set as a slave channel.
- (3) The slave channel must be lower than the master channel.

Example: If channel 2 is set as a master channel, channel 3 or those that follow (channels 3, 4, 5, etc.) can be set as a slave channel.

- (4) Two or more slave channels can be set for one master channel.
- (5) When two or more master channels are to be used, slave channels with a master channel between them may not be set.

Example: If channels 0 and 4 are set as master channels, channels 1 to 3 can be set as the slave channels of master channel 0. Channels 5 to 7 cannot be set as the slave channels of master channel 0.

- (6) The operating clock for a slave channel in combination with a master channel must be the same as that of the master channel. The CKSmn0, CKSmn1 bits (bit 15, 14 of timer mode register mn (TMRmn)) of the slave channel that operates in combination with the master channel must be the same value as that of the master channel.
- (7) A master channel can transmit INTTMmn (interrupt), start software trigger, and count clock to the lower channels.
- (8) A slave channel can use INTTMmn (interrupt), a start software trigger, or the count clock of the master channel as a source clock, but cannot transmit its own INTTMmn (interrupt), start software trigger, or count clock to channels with lower channel numbers.
- (9) A master channel cannot use INTTMmn (interrupt), a start software trigger, or the count clock from the other higher master channel as a source clock.
- (10) To simultaneously start channels that operate in combination, the channel start trigger bit (TSMn) of the channels in combination must be set at the same time.

<R> (11) During the counting operation, a TSMn bit of a master channel or TSMn bits of all channels which are operating simultaneously can be set. It cannot be applied to TSMn bits of slave channels alone.

- (12) To stop the channels in combination simultaneously, the channel stop trigger bit (TTmn) of the channels in combination must be set at the same time.

<R> (13) CKm2/CKm3 cannot be selected while channels are operating simultaneously, because the operating clocks of master channels and slave channels have to be synchronized.

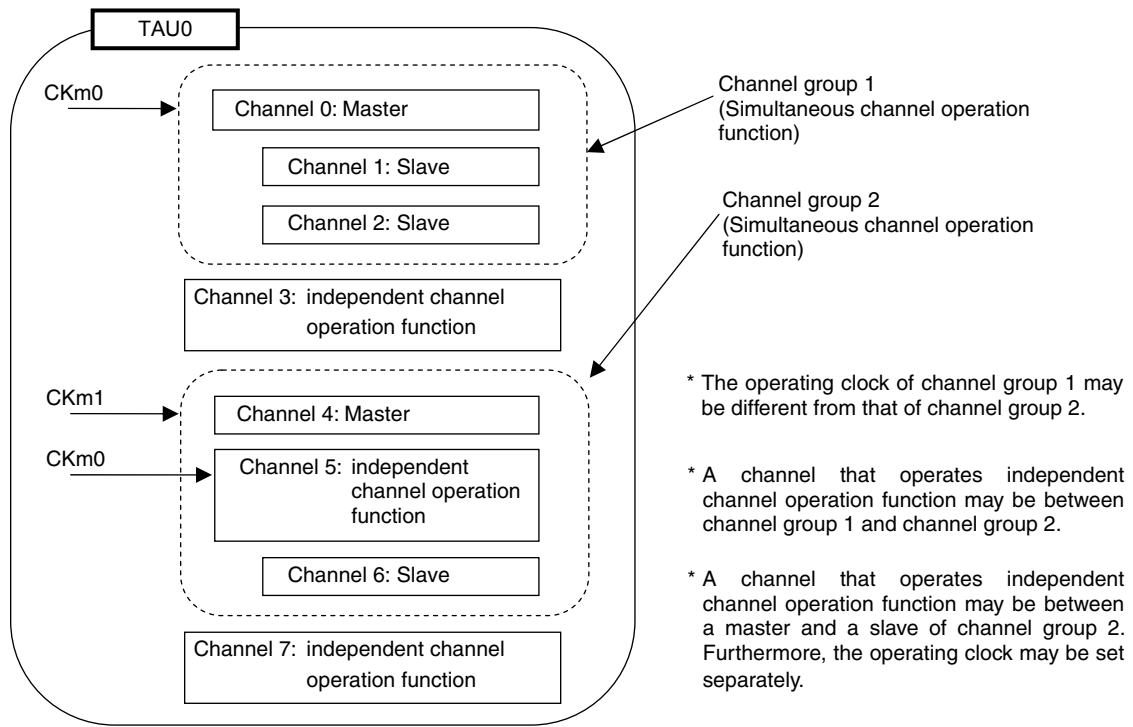
<R> (14) Timer mode register m0 (TMRm0) has no master bit (it is fixed as "0"). However, as channel 0 is the highest channel, it can be used as a master channel during simultaneous operation.

The rules of the simultaneous channel operation function are applied in a channel group (a master channel and slave channels forming one simultaneous channel operation function).

If two or more channel groups that do not operate in combination are specified, the basic rules of the simultaneous channel operation function in 6.4.1 **Basic rules of simultaneous channel operation function** do not apply to the channel groups.

**Remark** m: Unit number (m = 0, 1), n: Channel number (n = 0 to 7)

Example



- \* The operating clock of channel group 1 may be different from that of channel group 2.
- \* A channel that operates independent channel operation function may be between channel group 1 and channel group 2.
- \* A channel that operates independent channel operation function may be between a master and a slave of channel group 2. Furthermore, the operating clock may be set separately.

### 6.4.2 Basic rules of 8-bit timer operation function (channels 1 and 3 only)

The 8-bit timer operation function makes it possible to use a 16-bit timer channel in a configuration consisting of two 8-bit timer channels.

This function can only be used for channels 1 and 3, and there are several rules for using it.

The basic rules for this function are as follows:

- (1) The 8-bit timer operation function applies only to channels 1 and 3.
- (2) When using 8-bit timers, set the SPLIT bit of timer mode register mn (TMRmn) to 1.
- (3) The higher 8 bits can be operated as the interval timer function.
- (4) At the start of operation, the higher 8 bits output INTTm1H/INTTm3H (an interrupt) (which is the same operation performed when MDmn0 is set to 1).
- (5) The operation clock of the higher 8 bits is selected according to the CKSmn1 and CKSmn0 bits of the lower-bit TMRmn register.
- (6) For the higher 8 bits, the TSHm1/TSHm3 bit is manipulated to start channel operation and the TTHm1/TTHm3 bit is manipulated to stop channel operation. The channel status can be checked using the TEHm1/TEHm3 bit.
- (7) The lower 8 bits operate according to the TMRmn register settings. The following three functions support operation of the lower 8 bits:
  - Interval timer function
  - External event counter function
  - Delay count function
- (8) For the lower 8 bits, the TSm1/TSm3 bit is manipulated to start channel operation and the TTm1/TTm3 bit is manipulated to stop channel operation. The channel status can be checked using the TEM1/TEm3 bit.
- (9) During 16-bit operation, manipulating the TSHm1, TSHm3, TTHm1, and TTHm3 bits is invalid. The TSm1, TSm3, TTm1, and TTm3 bits are manipulated to operate channels 1 and 3. The TEHm3 and TEHm1 bits are not changed.
- (10) For the 8-bit timer function, the simultaneous operation functions (one-shot pulse, PWM, and multiple PWM) cannot be used.

**Remark** m: Unit number (m = 0, 1), n: Channel number (n = 1, 3)

### 6.5 Operation Timing of Counter

#### 6.5.1 Count clock (f<sub>TCLK</sub>)

The count clock (f<sub>TCLK</sub>) of the timer array unit can be selected between following by CCS<sub>mn</sub> bit of timer mode register mn (TMR<sub>mn</sub>). .

- Operation clock (f<sub>MCK</sub>) specified by the CKS<sub>mn0</sub> and CKS<sub>mn1</sub> bits
- Valid edge of input signal input from the TImn pin

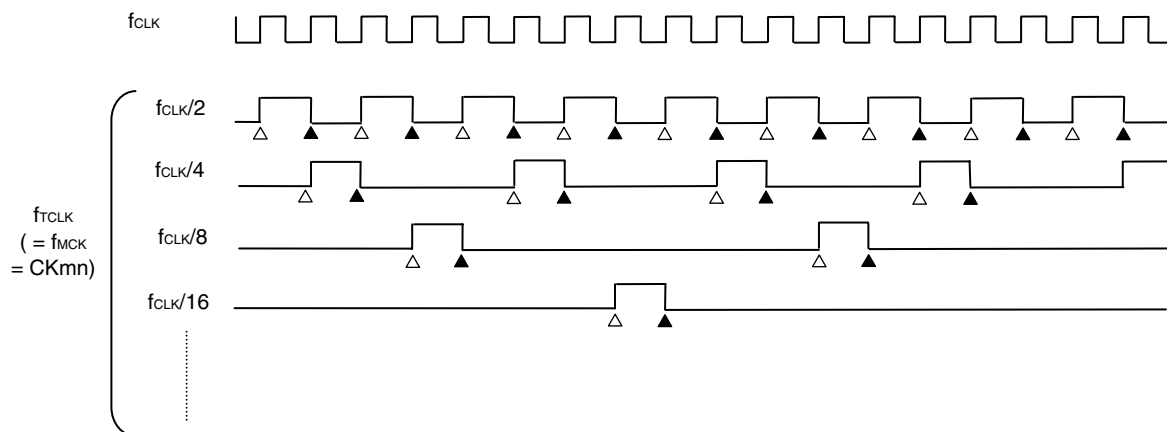
Because the timer array unit is designed to operate in synchronization with f<sub>CLK</sub>, the timings of the count clock (f<sub>TCLK</sub>) are shown below.

#### (1) When operation clock (f<sub>MCK</sub>) specified by the CKS<sub>mn0</sub> and CKS<sub>mn1</sub> bits is selected (CCS<sub>mn</sub> = 0)

The count clock (f<sub>TCLK</sub>) is between f<sub>CLK</sub> to f<sub>CLK</sub> / 2<sup>15</sup> by setting of timer clock select register m (TPS<sub>m</sub>). When a divided f<sub>CLK</sub> is selected, however, the count clock is not a signal which is simply divided f<sub>CLK</sub> by 2<sup>m</sup>, but a signal which becomes high level for one period of f<sub>CLK</sub> from its rising edge (m = 1 to 15).

Counting of timer count register mn (TCR<sub>mn</sub>) delayed by one period of f<sub>CLK</sub> from rising edge of the count clock, because of synchronization with f<sub>CLK</sub>. But, this is described as “counting at rising edge of the count clock”, as a matter of convenience.

**Figure 6-21. Timing of f<sub>CLK</sub> and count clock (f<sub>TCLK</sub>) (When CCS<sub>mn</sub> = 0)**



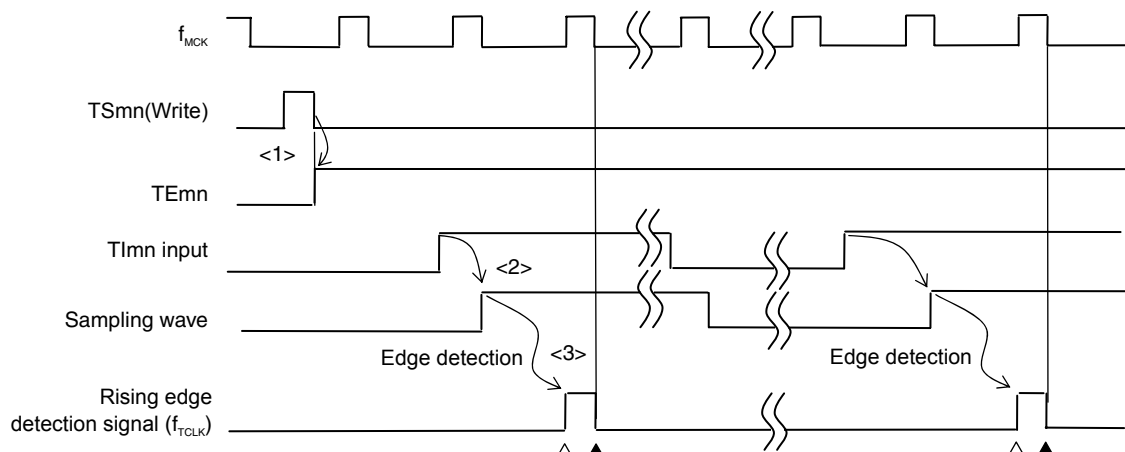
- Remarks 1.** Δ : Rising edge of the count clock  
 ▲ : Synchronization, increment/decrement of counter
- 2.** f<sub>CLK</sub>: CPU/peripheral hardware clock

**(2) When valid edge of input signal via the TImn pin is selected (CCSmn = 1)**

The count clock ( $f_{TCLK}$ ) becomes the signal that detects valid edge of input signal via the TImn pin and synchronizes next rising  $f_{MCK}$ . The count clock ( $f_{TCLK}$ ) is delayed for 1 to 2 period of  $f_{MCK}$  from the input signal via the TImn pin (when a noise filter is used, the delay becomes 3 to 4 clock).

Counting of timer count register mn (TCRmn) delayed by one period of  $f_{CLK}$  from rising edge of the count clock, because of synchronization with  $f_{CLK}$ . But, this is described as “counting at valid edge of input signal via the TImn pin”, as a matter of convenience.

**Figure 6-22. Timing of  $f_{CLK}$  and count clock ( $f_{TCLK}$ ) (When CCSmn = 1, noise filter unused)**



<1> Setting TSmn bit to 1 enables the timer to be started and to become wait state for valid edge of input signal via the TImn pin.

<2> The rise of input signal via the TImn pin is sampled by  $f_{MCK}$ .

<3> The edge is detected by the rising of the sampled signal and the detection signal (count clock) is output.

**Remarks 1.** △ : Rising edge of the count clock

▲ : Synchronization, increment/decrement of counter

**2.**  $f_{CLK}$ : CPU/peripheral hardware clock

$f_{MCK}$ : Operation clock of channel n

**3.** The waveform of the input signal via TImn pin of the input pulse interval measurement, the measurement of high/low width of input signal, and the delay counter, the one-shot pulse output are the same as that shown in Figure 6-22.

### 6.5.2 Start timing of counter

Timer count register mn (TCRmn) becomes enabled to operation by setting of TSmn bit of timer channel start register m (TSM).

Operations from count operation enabled state to timer count Register mn (TCRmn) count start is shown in Table 6-6.

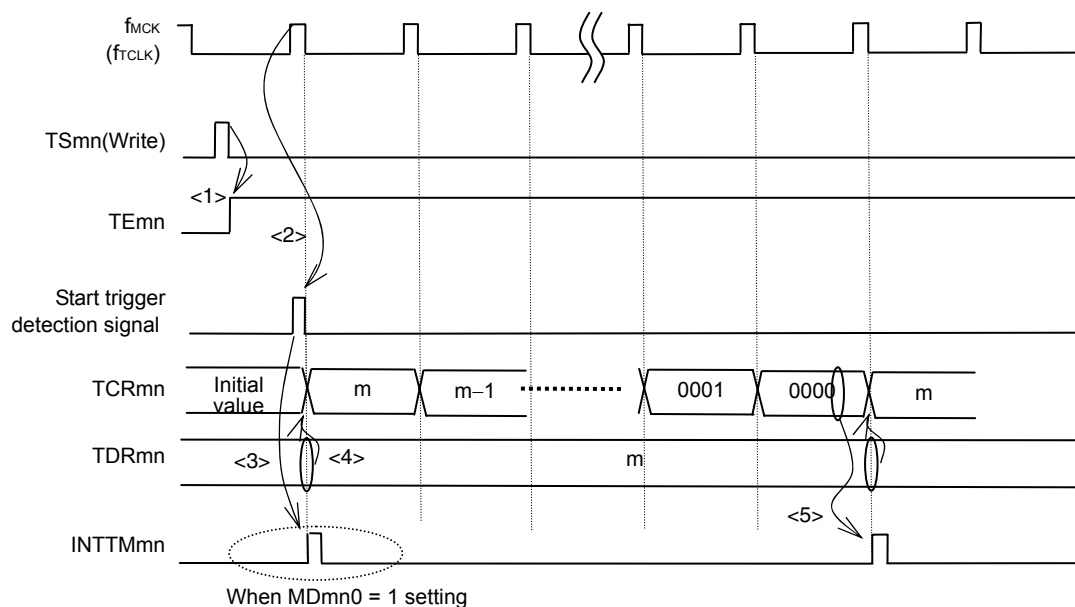
**Table 6-6. Operations from Count Operation Enabled State to Timer count Register mn (TCRmn) Count Start**

Timer operation mode	Operation when TSmn = 1 is set
<ul style="list-style-type: none"> <li>Interval timer mode</li> </ul>	<p>No operation is carried out from start trigger detection (TSmn=1) until count clock generation.</p> <p>The first count clock loads the value of the TDRmn register to the TCRmn register and the subsequent count clock performs count down operation (see <b>6.5.2 (a) Start timing in interval timer mode</b>).</p>
<ul style="list-style-type: none"> <li>Event counter mode</li> </ul>	<p>Writing 1 to the TSmn bit loads the value of the TDRmn register to the TCRmn register.</p> <p>The subsequent count clock performs count down operation.</p> <p>The external trigger detection selected by the STSmn2 to STSmn0 bits in the TMRmn register does not start count operation (see <b>6.5.2 (b) Start timing in event counter mode</b>).</p>
<ul style="list-style-type: none"> <li>Capture mode</li> </ul>	<p>No operation is carried out from start trigger detection until count clock generation.</p> <p>The first count clock loads 0000H to the TCRmn register and the subsequent count clock performs count up operation (see <b>6.5.2 (c) Start timing in capture mode</b>).</p>
<ul style="list-style-type: none"> <li>One-count mode</li> </ul>	<p>The waiting-for-start-trigger state is entered by writing 1 to the TSmn bit while the timer is stopped (TEmn = 0).</p> <p>No operation is carried out from start trigger detection until count clock generation.</p> <p>The first count clock loads the value of the TDRmn register to the TCRmn register and the subsequent count clock performs count down operation (see <b>6.5.2 (d) Start timing in one-count mode</b>).</p>
<ul style="list-style-type: none"> <li>Capture &amp; one-count mode</li> </ul>	<p>The waiting-for-start-trigger state is entered by writing 1 to the TSmn bit while the timer is stopped (TEmn = 0).</p> <p>No operation is carried out from start trigger detection until count clock generation.</p> <p>The first count clock loads 0000H to the TCRmn register and the subsequent count clock performs count up operation (see <b>6.5.2 (e) Start timing in capture &amp; one-count mode</b>).</p>

(a) Start timing in interval timer mode

- <1> Operation is enabled (TE<sub>mn</sub> = 1) by writing 1 to the TS<sub>mn</sub> bit. Timer count register mn (TCR<sub>mn</sub>) holds the initial value until count clock generation.
- <2> A start trigger is generated at the first count clock after operation is enabled.
- <3> When the MD<sub>mn0</sub> bit is set to 1, INTT<sub>mn</sub> is generated by the start trigger.
- <4> By the first count clock after the operation enable, the value of timer data register mn (TDR<sub>mn</sub>) is loaded to the TCR<sub>mn</sub> register and counting starts in the interval timer mode.
- <5> When the TCR<sub>mn</sub> register counts down and its count value is 0000H, INTT<sub>mn</sub> is generated and the value of timer data register mn (TDR<sub>mn</sub>) is loaded to the TCR<sub>mn</sub> register and counting keeps on.

Figure 6-23. Start Timing (In Interval Timer Mode)



**Remark**  $f_{MCK}$ , the start trigger detection signal, and  $INTT_{mn}$  become active between one clock in synchronization with  $f_{CLK}$ .

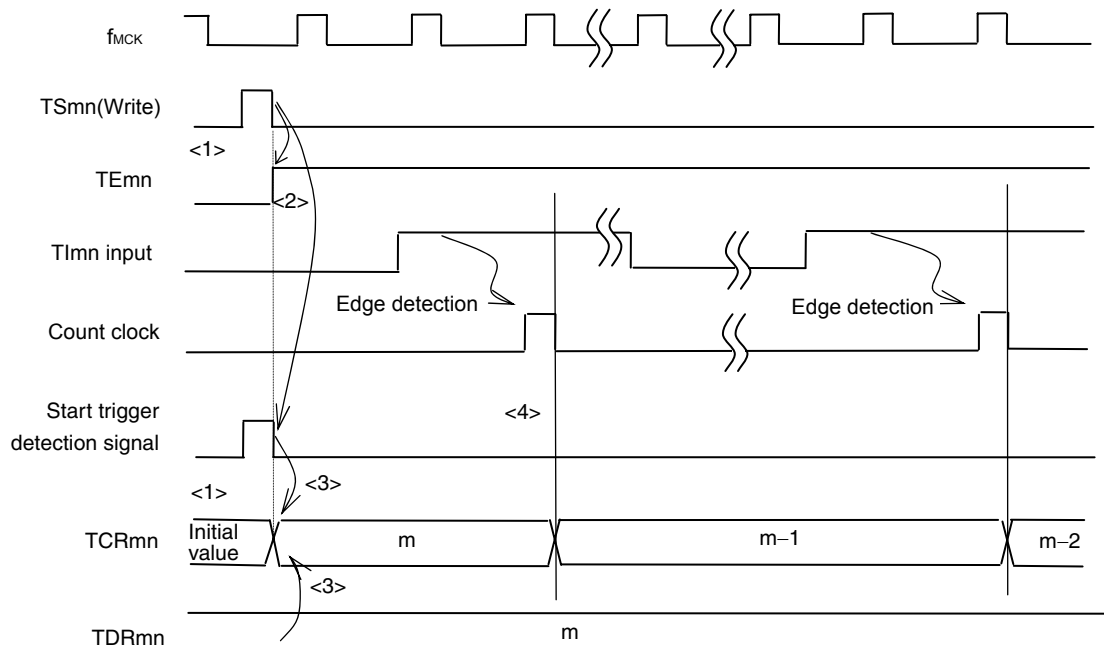
**Caution** In the first cycle operation of count clock after writing the  $TS_{mn}$  bit, an error at a maximum of one clock is generated since count start delays until count clock has been generated. When the information on count start timing is necessary, an interrupt can be generated at count start by setting  $MD_{mn0} = 1$ .



**(b) Start timing in event counter mode**

- <1> Timer count register mn (TCRmn) holds its initial value while operation is stopped (TEmn = 0).
- <2> Operation is enabled (TEmn = 1) by writing 1 to the TSmn bit.
- <3> As soon as 1 has been written to the TSmn bit and 1 has been set to the TEMn bit, the value of timer data register mn (TDRmn) is loaded to the TCRmn register to start counting.
- <4> After that, the TCRmn register value is counted down according to the count clock of the valid edge of the TImn input .

**Figure 6-24. Start Timing (In Event Counter Mode)**

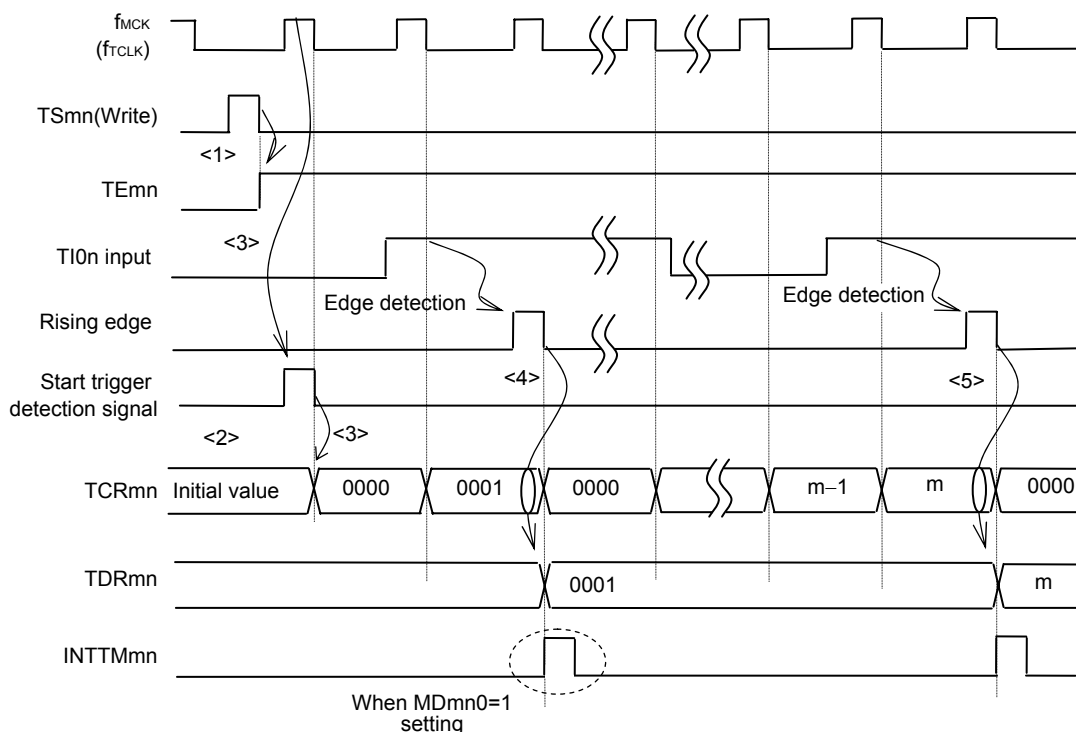


**Remark** The timing is shown in Figure 6-24 indicates while the noise filter is not used. By making the noise filter on-state, the edge detection becomes 2 f<sub>MCK</sub> cycles (it sums up to 3 to 4 cycles) later than the normal cycle of TImn input.

(c) Start timing in capture mode

- <1> Operation is enabled ( $TE_{mn} = 1$ ) by writing 1 to the  $TS_{mn}$  bit.
- <2> Timer count register  $mn$  ( $TCR_{mn}$ ) holds the initial value until count clock generation.
- <3> A start trigger is generated at the first count clock after operation is enabled. And the value of 0000H is loaded to the  $TCR_{mn}$  register and counting starts in the capture mode. (When the  $MD_{mn0}$  bit is set to 1,  $INTTM_{mn}$  is generated by the start trigger.)
- <4> On detection of the valid edge of the  $TI_{mn}$  input, the value of the  $TCR_{mn}$  register is captured to timer data register  $mn$  ( $TDR_{mn}$ ) and  $INTTM_{mn}$  is generated. However, this capture value is no meaning. The  $TCR_{mn}$  register keeps on counting from 0000H.
- <5> On next detection of the valid edge of the  $TI_{mn}$  input, the value of the  $TCR_{mn}$  register is captured to timer data register  $mn$  ( $TDR_{mn}$ ) and  $INTTM_{mn}$  is generated.

Figure 6-25. Start Timing (In Capture Mode)



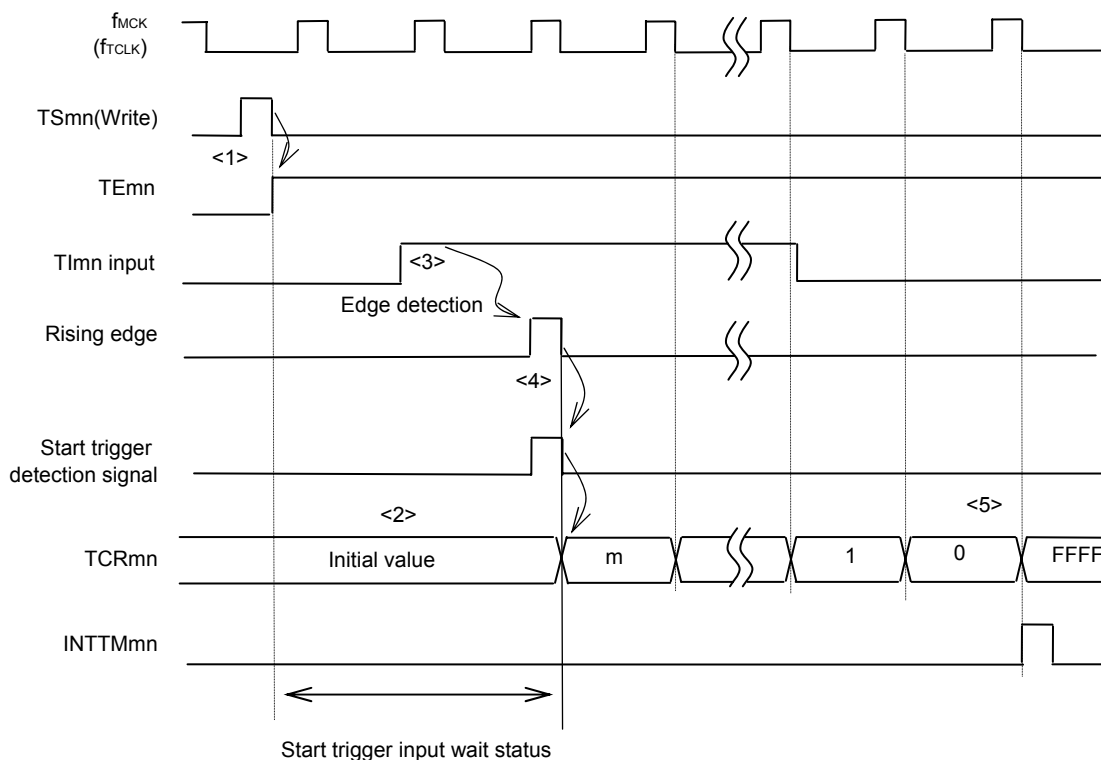
**Remark** The timing is shown in Figure 6-25 indicates while the noise filter is not used. By making the noise filter on-state, the edge detection becomes 2  $f_{MCK}$  cycles (it sums up to 3 to 4 cycles) later than the normal cycle of  $TI_{mn}$  input.

Since the start of the count and the timing of  $TI_{mn}$  input are asynchronous, the first capture value (<4> in Figure 6-24) has absolutely no connection with the pulse interval. Therefore, ignore the first capture value.

**Caution** In the first cycle operation of count clock after writing the  $TS_{mn}$  bit, an error at a maximum of one clock is generated since count start delays until count clock has been generated. When the information on count start timing is necessary, an interrupt can be generated at count start by setting  $MD_{mn0} = 1$ .

**(d) Start timing in one-count mode**

- <1> Operation is enabled ( $TE_{mn} = 1$ ) by writing 1 to the  $TS_{mn}$  bit.
- <2> Timer count register  $mn$  ( $TCR_{mn}$ ) holds the initial value until start trigger generation.
- <3> Rising edge of the  $TI_{mn}$  input is detected.
- <4> On start trigger detection, the value of timer data register  $mn$  ( $TDR_{mn}$ ) is loaded to the  $TCR_{mn}$  register and count starts.
- <5> When the  $TCR_{mn}$  register counts down and its count value is 0000H,  $INTTM_{mn}$  is generated and the value of the  $TCR_{mn}$  register becomes FFFFH and counting stops

**Figure 6-26. Start Timing (In One-count Mode)**

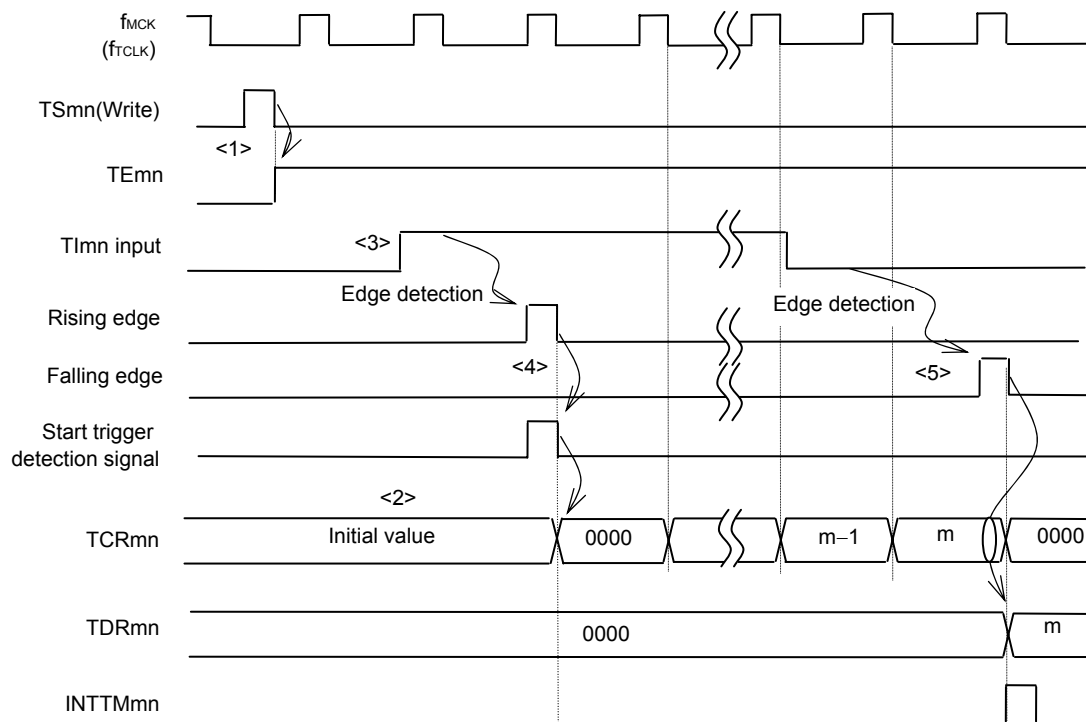
**Remark** The timing is shown in Figure 6-26 indicates while the noise filter is not used. By making the noise filter on-state, the edge detection becomes  $2 f_{MCK}$  cycles (it sums up to 3 to 4 cycles) later than the normal cycle of  $TI_{mn}$  input. The error per one period occurs because of the asynchronous between the period of the  $TI_{mn}$  input and that of the count clock ( $f_{MCK}$ ).

(e) Start timing in capture & one-count mode (when high-level width is measured)

- <1> Operation is enabled ( $TE_{mn} = 1$ ) by writing 1 to the  $TS_{mn}$  bit of timer channel start register  $m$  ( $TS_m$ ).
- <2> Timer count register  $mn$  ( $TCR_{mn}$ ) holds the initial value until start trigger generation.
- <3> Rising edge of the  $Tl_{mn}$  input is detected.
- <4> On start trigger detection, the value of 0000H is loaded to the  $TCR_{mn}$  register and count starts.
- <5> On detection of the falling edge of the  $Tl_{mn}$  input, the value of the  $TCR_{mn}$  register is captured to timer data register  $mn$  ( $TDR_{mn}$ ) and  $INTT_{mn}$  is generated.

<R>

Figure 6-27. Start Timing (In Capture & One-count Mode)



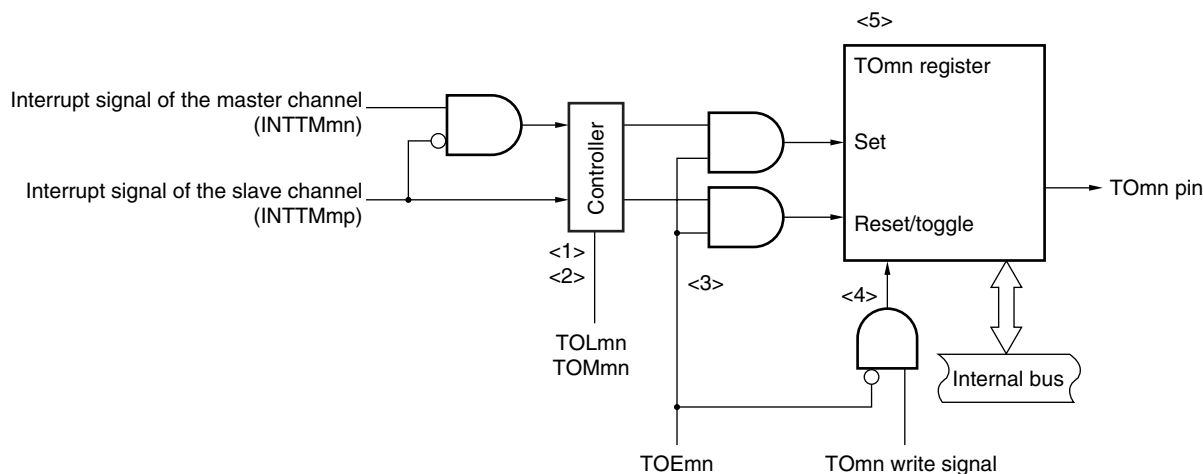
<R>

**Remark** The timing is shown in Figure 6-27 indicates while the noise filter is not used. By making the noise filter on-state, the edge detection becomes 2  $f_{MCK}$  cycles (it sums up to 3 to 4 cycles) later than the normal cycle of  $Tl_{mn}$  input.

## 6.6 Channel Output (TOMn pin) Control

### 6.6.1 TOMn pin output circuit configuration

Figure 6-28. Output Circuit Configuration



The following describes the TOMn pin output circuit.

- <1> When  $TOMmn = 0$  (master channel output mode), the set value of timer output level register  $m$  ( $TOLm$ ) is ignored and only  $INTTM0p$  (slave channel timer interrupt) is transmitted to timer output register  $m$  ( $TOM$ ).
- <2> When  $TOMmn = 1$  (slave channel output mode), both  $INTTMmn$  (master channel timer interrupt) and  $INTTM0p$  (slave channel timer interrupt) are transmitted to the  $TOM$  register. At this time, the  $TOLm$  register becomes valid and the signals are controlled as follows:

When $TOLmn = 0$ :	Forward operation ( $INTTMmn \rightarrow \text{set}$ , $INTTM0p \rightarrow \text{reset}$ )
When $TOLmn = 1$ :	Reverse operation ( $INTTMmn \rightarrow \text{reset}$ , $INTTM0p \rightarrow \text{set}$ )

When  $INTTMmn$  and  $INTTM0p$  are simultaneously generated, (0% output of PWM),  $INTTM0p$  (reset signal) takes priority, and  $INTTMmn$  (set signal) is masked.

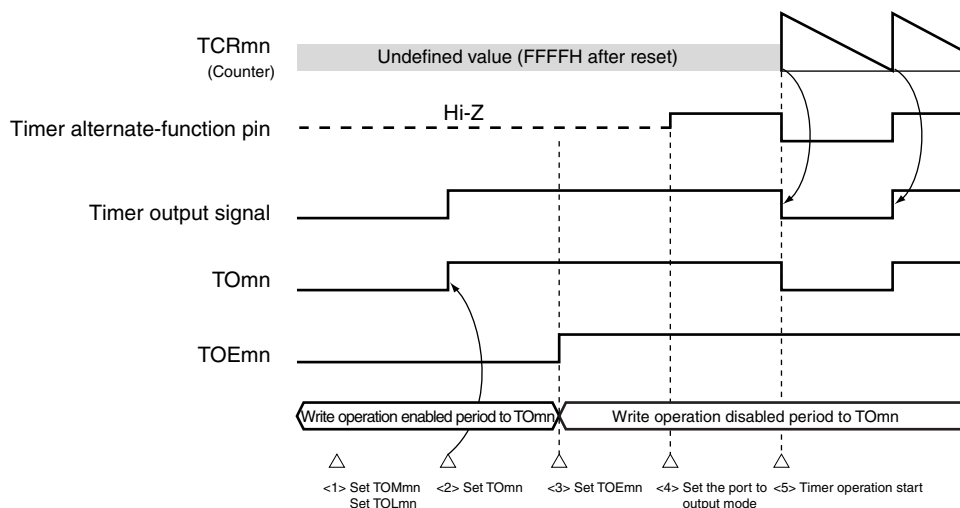
- <3> While timer output is enabled ( $TOEmn = 1$ ),  $INTTMmn$  (master channel timer interrupt) and  $INTTM0p$  (slave channel timer interrupt) are transmitted to the  $TOM$  register. Writing to the  $TOM$  register ( $TOMn$  write signal) becomes invalid. When  $TOEmn = 1$ , the  $TOMn$  pin output never changes with signals other than interrupt signals. To initialize the  $TOMn$  pin output level, it is necessary to set timer operation is stopeed ( $TOEmn = 0$ ) and to write a value to the  $TOM$  register.
- <4> While timer output is disabled ( $TOEmn = 0$ ), writing to the  $TOMn$  bit to the target channel ( $TOMn$  write signal) becomes valid. When timer output is disabled ( $TOEmn = 0$ ), neither  $INTTMmn$  (master channel timer interrupt) nor  $INTTM0p$  (slave channel timer interrupt) is transmitted to the  $TOM$  register.
- <5> The  $TOM$  register can always be read, and the  $TOMn$  pin output level can be checked.

**Remark**  $m$ : Unit number ( $m = 0, 1$ )  
 $n$ : Channel number  
 $n = 0$  to  $7$  ( $n = 0, 2, 4, 6$  for master channel)  
 $p$ : Slave channel number  
 $n < p \leq 7$

### 6.6.2 TOmn Pin Output Setting

The following figure shows the procedure and status transition of the TOmn output pin from initial setting to timer operation start.

**Figure 6-29. Status Transition from Timer Output Setting to Operation Start**



<1> The operation mode of timer output is set.

- TOMmn bit (0: Master channel output mode, 1: Slave channel output mode)
- TOLmn bit (0: Positive logic output, 1: Negative logic output)

<2> The timer output signal is set to the initial status by setting timer output register m (TOmn).

<3> The timer output operation is enabled by writing 1 to the TOEmn bit (writing to the TOm register is disabled).

<4> The port I/O setting is set to output (see **6.3 (15) Port mode registers 0, 1, 3, 4, 6, 10, 14 (PM0, PM1, PM3, PM4, PM6, PM10, PM14)**).

<5> The timer operation is enabled (TSmn = 1).

**Remark** m: Unit number (m = 0, 1), n: Channel number (n = 0 to 7)

### 6.6.3 Cautions on Channel Output Operation

#### (1) Changing values set in the registers TOM, TOEm, TOLm, and TOMm during timer operation

Since the timer operations (operations of timer count register mn (TCRmn) and timer data register mn (TDRmn)) are independent of the TOMn output circuit and changing the values set in timer output register m (TOM), timer output enable register m (TOEm), timer output level register m (TOLm), and timer output mode register m (TOMm) does not affect the timer operation, the values can be changed during timer operation. To output an expected waveform from the TOMn pin by timer operation, however, set the TOM, TOEm, TOLm, and TOMm registers to the values stated in the register setting example of each operation shown by 6.7 and 6.8.

When the values set to the TOEm, TOLm, and TOMm registers (but not the TOM register) are changed close to the occurrence of the timer interrupt (INTTMmn) of each channel, the waveform output to the TOMn pin might differ, depending on whether the values are changed immediately before or immediately after the timer interrupt (INTTMmn) occurs.

**Remark** m: Unit number (m = 0, 1), n: Channel number (n = 0 to 7)

**(2) Default level of TOMn pin and output level after timer operation start**

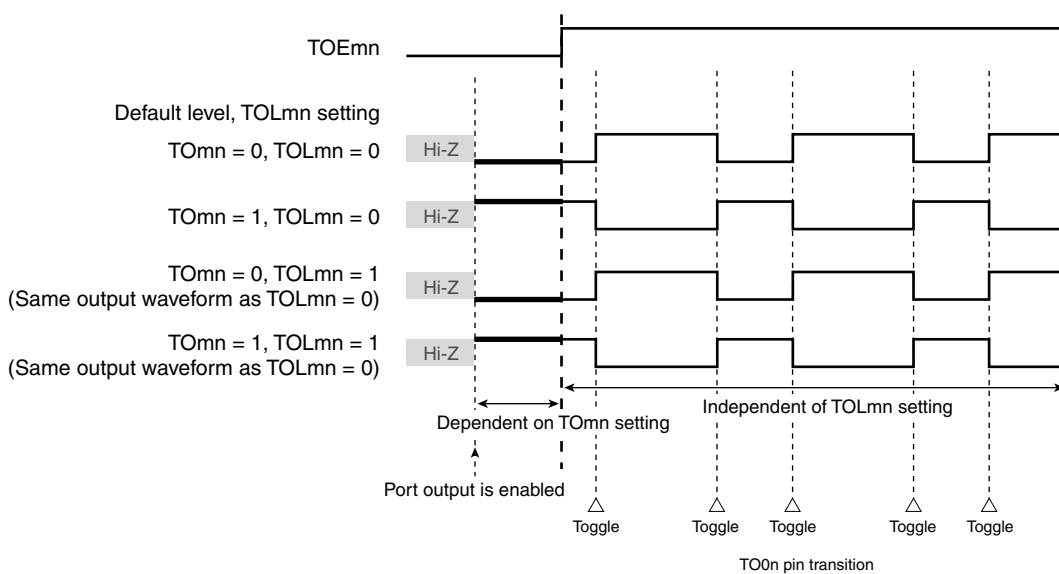
The change in the output level of the TOMn pin when timer output register m (TOM) is written while timer output is disabled (TOEmn = 0), the initial level is changed, and then timer output is enabled (TOEmn = 1) before port output is enabled, is shown below.

**(a) When operation starts with master channel output mode (TOMmn = 0) setting**

The setting of timer output level register m (TOLm) is invalid when master channel output mode (TOMmn = 0). When the timer operation starts after setting the default level, the toggle signal is generated and the output level of the TOMn pin is reversed.

<R>

**Figure 6-30. TOMn Pin Output Status at Toggle Output (TOMmn = 0)**



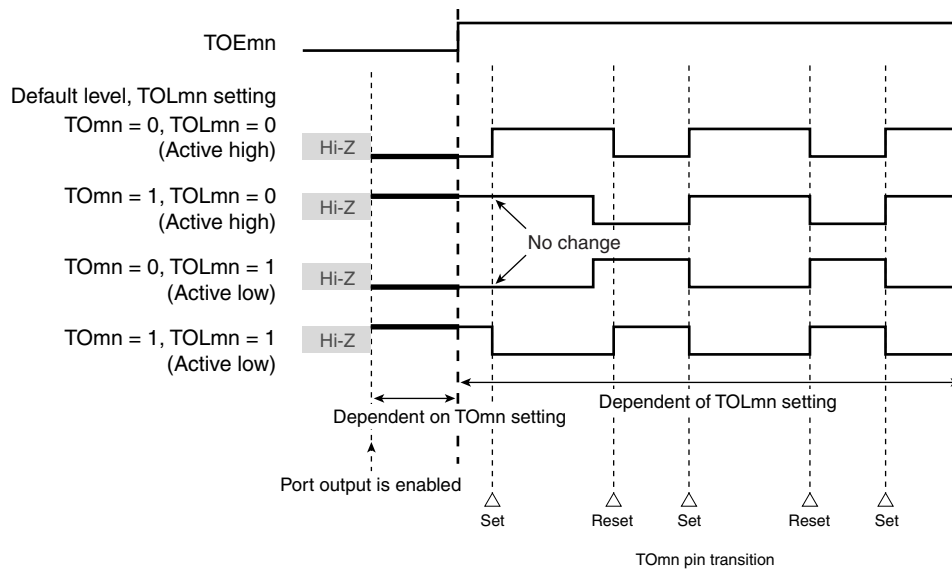
- Remarks 1.** Toggle: Reverse TOMn pin output status
- 2.** m: Unit number (m = 0, 1), n: Channel number (n = 0 to 7)



**(b) When operation starts with slave channel output mode (TOMmn = 1) setting (PWM output)**

When slave channel output mode (TOMmn = 1), the active level is determined by timer output level register m (TOLm) setting.

**Figure 6-31. TOMn Pin Output Status at PWM Output (TOMmn = 1)**



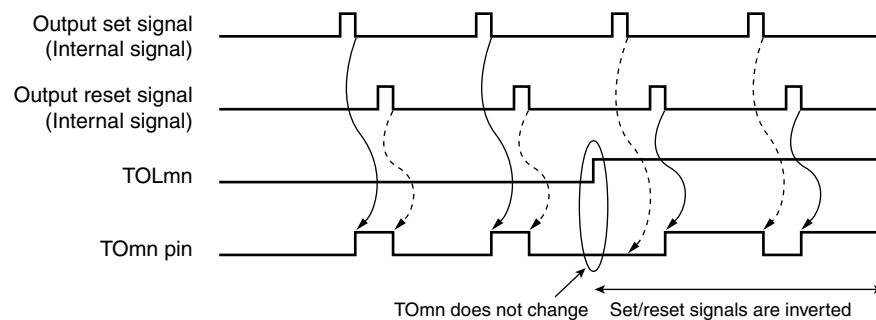
- Remarks 1.** Set: The output signal of the TOMn pin changes from inactive level to active level.  
 Reset: The output signal of the TOMn pin changes from active level to inactive level.
- 2.** m: Unit number (m = 0, 1), n: Channel number (n = 0 to 7)

**(3) Operation of TOMn pin in slave channel output mode (TOMmn = 1)****(a) When timer output level register m (TOLm) setting has been changed during timer operation**

When the TOLm register setting has been changed during timer operation, the setting becomes valid at the generation timing of the TOMn pin change condition. Rewriting the TOLm register does not change the output level of the TOMn pin.

The operation when TOMmn is set to 1 and the value of the TOLm register is changed while the timer is operating (TEMn = 1) is shown below.

**Figure 6-32. Operation when TOLm Register Has Been Changed during Timer Operation**



- Remarks 1.** Set: The output signal of the TOMn pin changes from inactive level to active level.  
 Reset: The output signal of the TOMn pin changes from active level to inactive level.
- 2.** m: Unit number (m = 0, 1), n: Channel number (n = 0 to 7)

**(b) Set/reset timing**

To realize 0%/100% output at PWM output, the TOMn pin/TOMn bit set timing at master channel timer interrupt (INTTMmn) generation is delayed by 1 count clock by the slave channel.

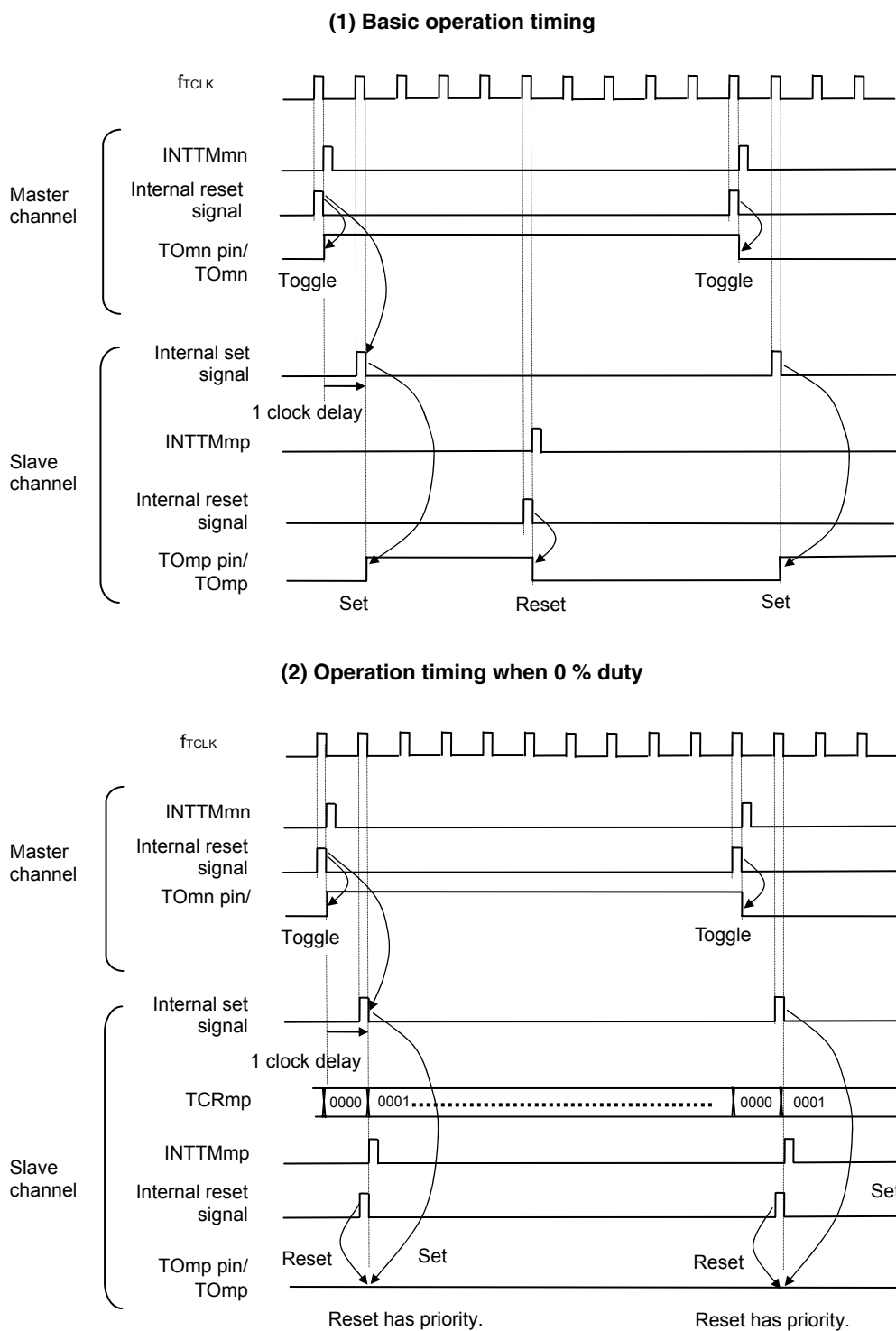
If the set condition and reset condition are generated at the same time, a higher priority is given to the latter.

Figure 6-33 shows the set/reset operating statuses where the master/slave channels are set as follows.

Master channel: TOEmn = 1, TOMmn = 0, TOLmn = 0

Slave channel: TOEmp = 1, TOMmp = 1, TOLmp = 0

Figure 6-33. Set/Reset Timing Operating Statuses



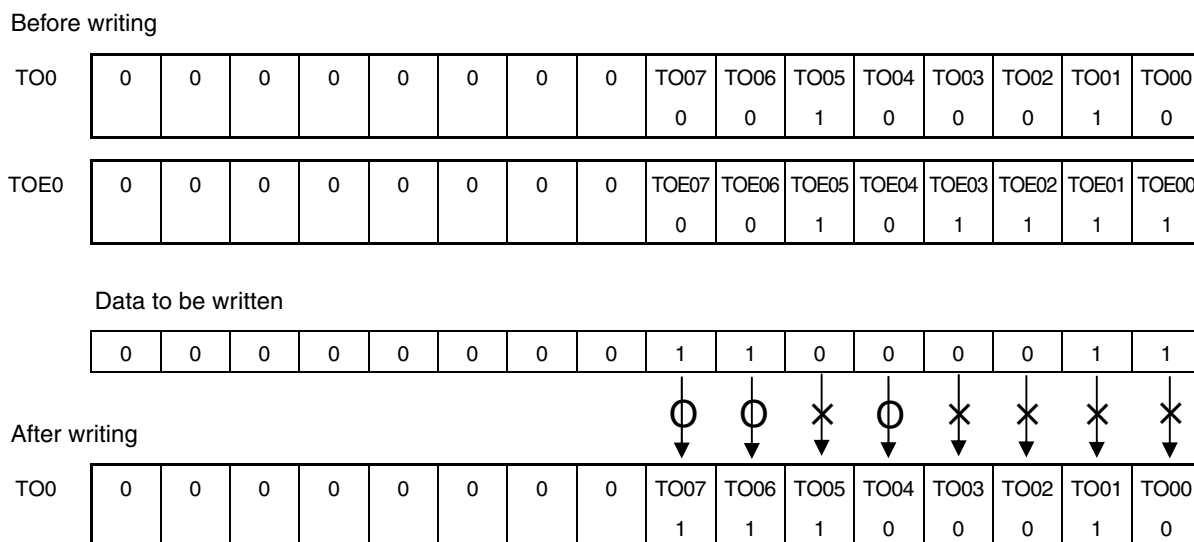
- Remarks 1.** Internal reset signal: TOmn pin reset/toggle signal  
 Internal set signal: TOmn pin set signal
- 2.** m: Unit number (m = 0, 1)  
 n: Channel number (n = 0 to 7)  
 n = 0 to 7 (n = 0, 2, 4, 6 for master channel)  
 p: Slave channel number  
 n < p ≤ 7

**6.6.4 Collective manipulation of TOMn bit**

In timer output register m (TOM), the setting bits for all the channels are located in one register in the same way as timer channel start register m (TSM). Therefore, the TOMn bit of all the channels can be manipulated collectively.

Only the desired bits can also be manipulated by enabling writing only to the TOMn bits (TOEmn = 0) that correspond to the relevant bits of the channel used to perform output (TOMn).

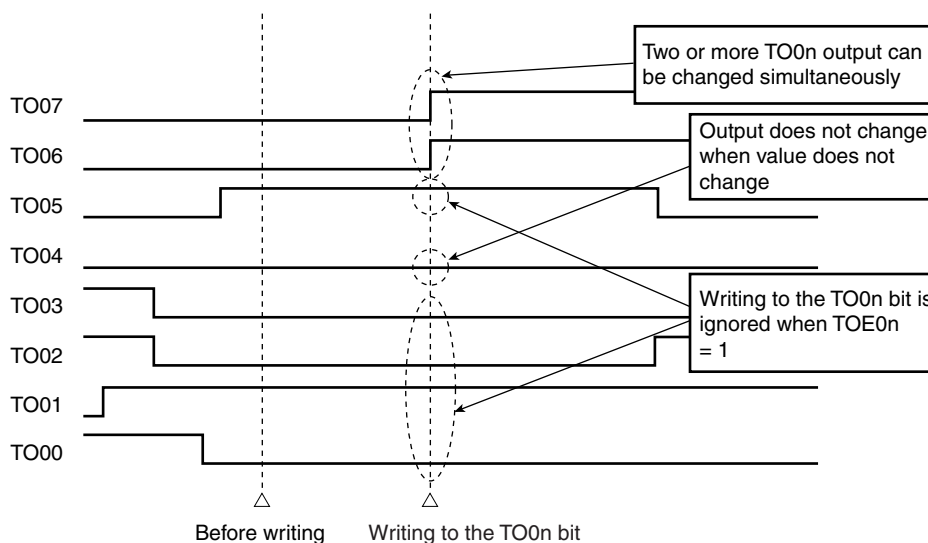
**Figure 6-34 Example of TO0n Bit Collective Manipulation**



Writing is done only to the TOMn bit with TOEmn = 0, and writing to the TOMn bit with TOEmn = 1 is ignored.

TOMn (channel output) to which TOEmn = 1 is set is not affected by the write operation. Even if the write operation is done to the TOMn bit, it is ignored and the output change by timer operation is normally done.

**Figure 6-35. TO0n Pin Statuses by Collective Manipulation of TO0n Bit**



(Caution and Remark are given on the next page.)

**Caution** While timer output is enabled ( $TOEmn = 1$ ), even if the output by timer interrupt of each timer ( $INTTMmn$ ) contends with writing to the  $TOmn$  bit, output is normally done to the  $TOmn$  pin.

**Remark** m: Unit number ( $m = 0, 1$ ), n: Channel number ( $n = 0$  to 7)

### 6.6.5 Timer Interrupt and $TOmn$ Pin Output at Operation Start

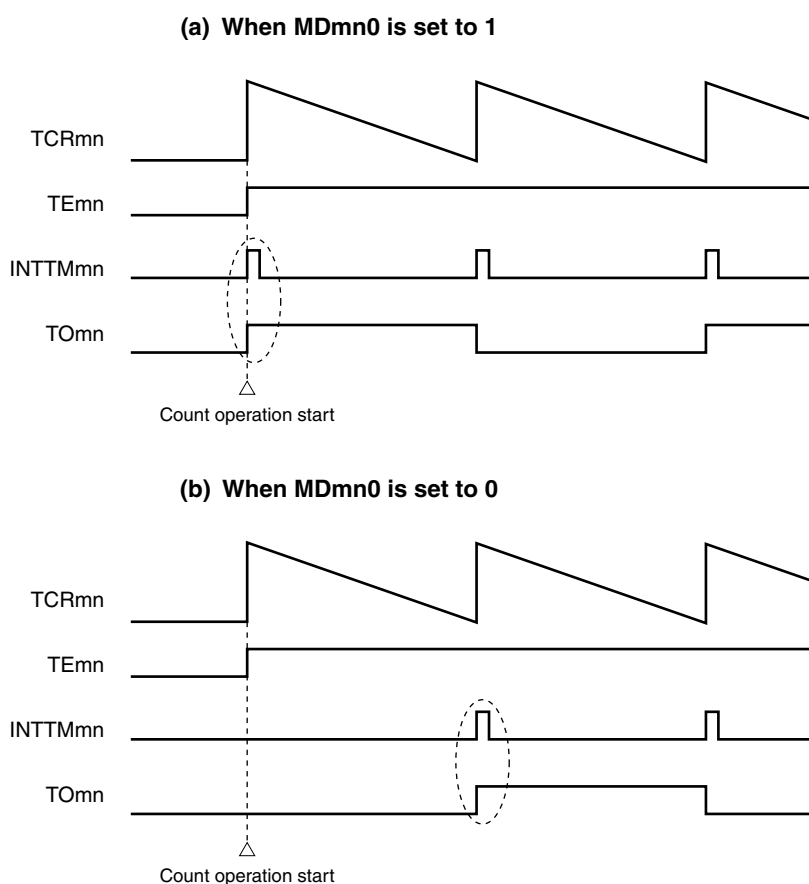
In the interval timer mode or capture mode, the  $MDmn0$  bit in timer mode register mn ( $TMRmn$ ) sets whether or not to generate a timer interrupt at count start.

When  $MDmn0$  is set to 1, the count operation start timing can be known by the timer interrupt ( $INTTMmn$ ) generation.

In the other modes, neither timer interrupt at count operation start nor  $TOmn$  output is controlled.

Figure 6-36 shows operation examples when the interval timer mode ( $TOEmn = 1$ ,  $TOMmn = 0$ ) is set.

**Figure 6-36. Operation examples of timer interrupt at count operation start and  $TOmn$  output**



When  $MDmn0$  is set to 1, a timer interrupt ( $INTTMmn$ ) is output at count operation start, and  $TOmn$  performs a toggle operation.

When  $MDmn0$  is set to 0, a timer interrupt ( $INTTMmn$ ) is not output at count operation start, and  $TOmn$  does not change either. After counting one cycle,  $INTTMmn$  is output and  $TOmn$  performs a toggle operation.

**Remark** m: Unit number ( $m = 0, 1$ ), n: Channel number ( $n = 0$  to 7)

## 6.7 Independent Channel Operation Function of Timer Array Unit

### 6.7.1 Operation as interval timer/square wave output

#### (1) Interval timer

The timer array unit can be used as a reference timer that generates INTTMmn (timer interrupt) at fixed intervals. The interrupt generation period can be calculated by the following expression.

$$\text{Generation period of INTTMmn (timer interrupt)} = \text{Period of count clock} \times (\text{Set value of TDRmn} + 1)$$

#### (2) Operation as square wave output

TOMn performs a toggle operation as soon as INTTMmn has been generated, and outputs a square wave with a duty factor of 50%.

The period and frequency for outputting a square wave from TOMn can be calculated by the following expressions.

$$\bullet \text{ Period of square wave output from TOMn} = \text{Period of count clock} \times (\text{Set value of TDRmn} + 1) \times 2$$

$$\bullet \text{ Frequency of square wave output from TOMn} = \text{Frequency of count clock} / \{(\text{Set value of TDRmn} + 1) \times 2\}$$

Timer count register mn (TCRmn) operates as a down counter in the interval timer mode.

The TCRmn register loads the value of timer data register mn (TDRmn) at the first count clock after the channel start trigger bit (TSmn, TSHm1, TSHm3) of timer channel start register m (TSm) is set to 1. If the MDmn0 bit of timer mode register mn (TMRmn) is 0 at this time, INTTMmn is not output and TOMn is not toggled. If the MDmn0 bit of the TMRmn register is 1, INTTMmn is output and TOMn is toggled.

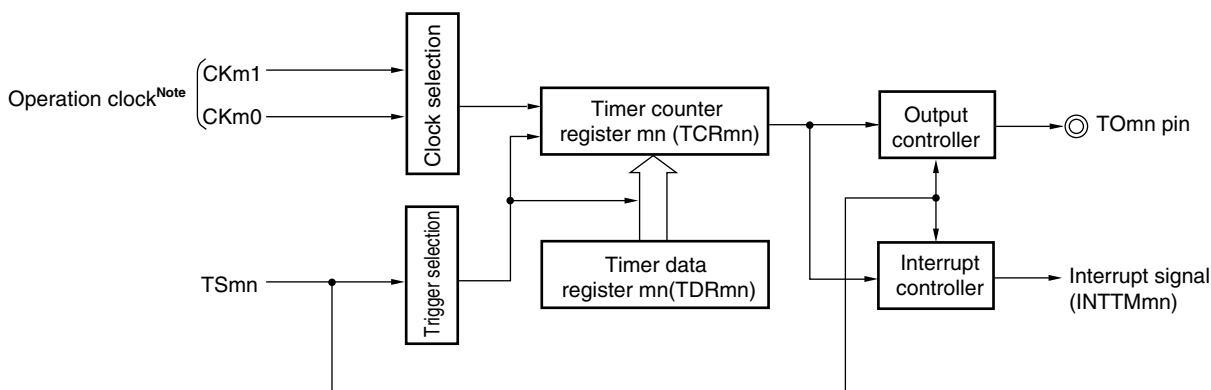
After that, the TCRmn register count down in synchronization with the count clock.

When TCRmn = 0000H, INTTMmn is output and TOMn is toggled at the next count clock. At the same time, the TCRmn register loads the value of the TDRmn register again. After that, the same operation is repeated.

The TDRmn register can be rewritten at any time. The new value of the TDRmn register becomes valid from the next period.

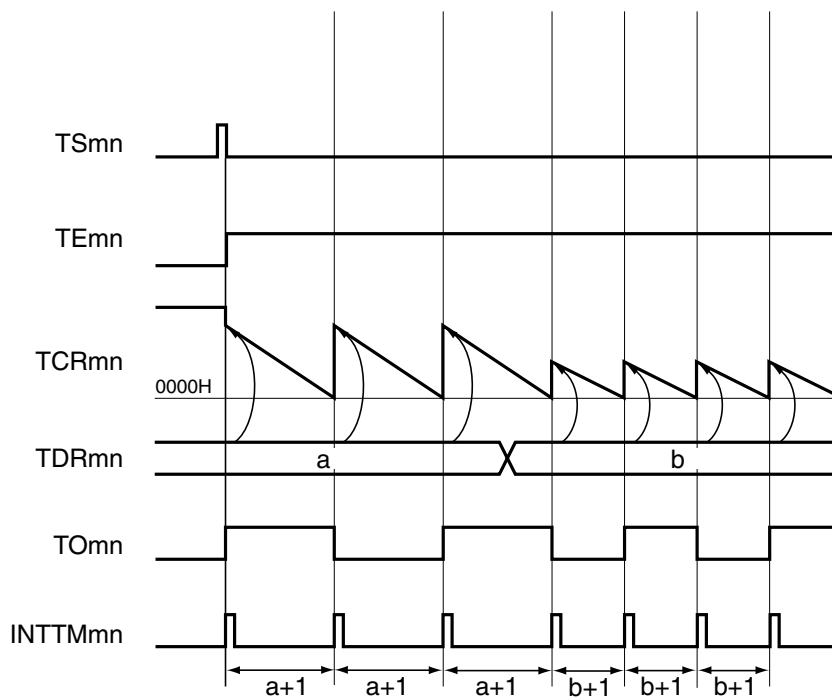
**Remark** m: Unit number (m = 0, 1), n: Channel number (n = 0 to 7)

Figure 6-37. Block Diagram of Operation as Interval Timer/Square Wave Output



<R> **Note** When channels 1 and 3, the clock can be selected from CKm0, CKm1, CKm2 and CKm3.

Figure 6-38. Example of Basic Timing of Operation as Interval Timer/Square Wave Output (MDmn0 = 1)

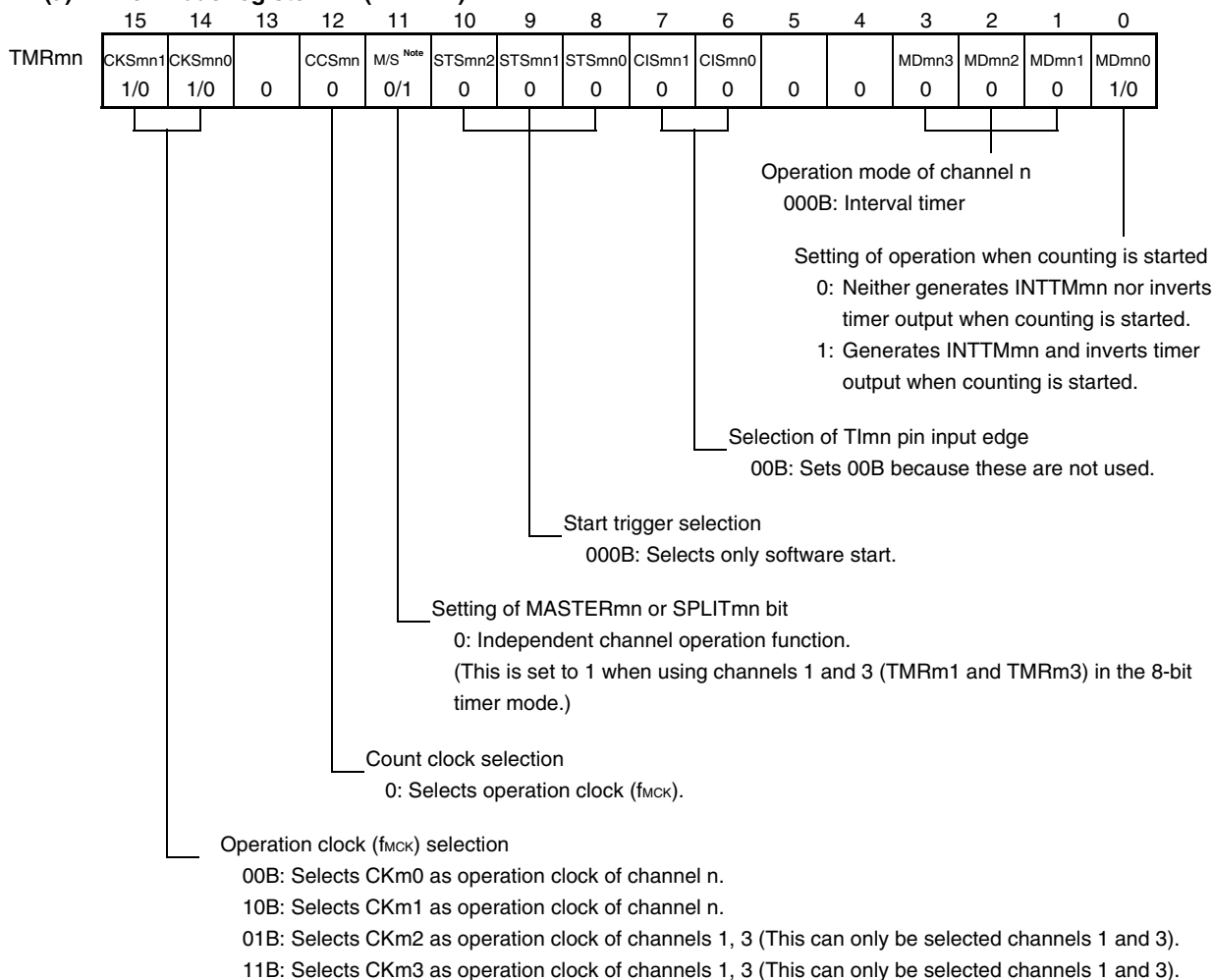


- Remarks**
1. m: Unit number (m = 0, 1), n: Channel number (n = 0 to 7)
  2. TSmn: Bit n of timer channel start register m (TSm)
  - TEmn: Bit n of timer channel enable status register m (TEm)
  - TCRmn: Timer count register mn (TCRmn)
  - TDRmn: Timer data register mn (TDRmn)
  - TOn: TOn pin output signal

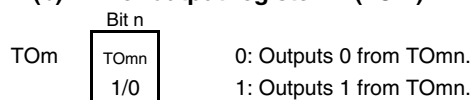


Figure 6-39. Example of Set Contents of Registers During Operation as Interval Timer/Square Wave Output (1/2)

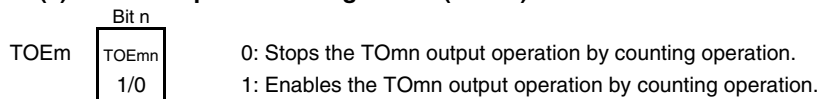
(a) Timer mode register mn (TMRmn)



(b) Timer output register m (TOM)



(c) Timer output enable register m (TOEm)



**Note** TMRm2, TMRm4, TMRm6: MASTERmn bit  
 TMRm1, TMRm3: SPLITmn bit  
 TMRm0, TMRm5, TMRm7: Fixed to 0

**Remark** m: Unit number (m = 0, 1), n: Channel number (n = 0 to 7)

**Figure 6-39. Example of Set Contents of Registers During Operation as Interval Timer/Square Wave Output (2/2)****(d) Timer output level register m (TOLm)**

TOLm 

Bit n
TOLmn
0

 0: Cleared to 0 when TOMmn = 0 (master channel output mode)

**(e) Timer output mode register m (TOMm)**

TOMm 

Bit n
TOMmn
0

 0: Sets master channel output mode.

**Remark** m: Unit number (m = 0, 1), n: Channel number (n = 0 to 7)

Figure 6-40. Operation Procedure of Interval Timer/Square Wave Output Function (1/2)

	Software Operation	Hardware Status
TAU default setting		Power-off status (Clock supply is stopped and writing to each register is disabled.)
	Sets the TAUmEN bit of peripheral enable register 0 (PER0) to 1.	Power-on status. Each channel stops operating. (Clock supply is started and writing to each register is enabled.)
	Sets timer clock select register m (TPSm). Determines clock frequencies of CKm0 and CKm1 (or CKm2 and CKm3 when using the 8-bit timer mode).	
Channel default setting	Sets timer mode register mn (TMRmn) (determines operation mode of channel). Sets interval (period) value to timer data register mn (TDRmn).	Channel stops operating. (Clock is supplied and some power is consumed.)
	To use the TOMn output Clears the TOMmn bit of timer output mode register m (TOMm) to 0 (master channel output mode). Clears the TOLmn bit to 0. Sets the TOMn bit and determines default level of the TOMn output.	The TOMn pin goes into Hi-Z output state.  The TOMn default setting level is output when the port mode register is in the output mode and the port register is 0.
	Sets the TOEmn bit to 1 and enables operation of TOMn. Clears the port register and port mode register to 0.	TOMn does not change because channel stops operating. The TOMn pin outputs the TOMn set level.
Operation start	(Sets the TOEmn bit to 1 only if using TOMn output and resuming operation.) Sets the TSmn (TSHm1, TSHm3) bit to 1. The TSmn (TSHm1, TSHm3) bit automatically returns to 0 because it is a trigger bit.	TEmn (TEHm1, TEHm3) = 1, and count operation starts. Value of the TDRmn register is loaded to timer count register mn (TCRmn) at the count clock input. INTTMmn is generated and TOMn performs toggle operation if the MDmn0 bit of the TMRmn register is 1.
During operation	Set values of the TMRmn register, TOMmn, and TOLmn bits cannot be changed. Set value of the TDRmn register can be changed. The TCRmn register can always be read. The TSRmn register is not used. Set values of the TOM and TOEm registers can be changed.	Counter (TCRmn) counts down. When count value reaches 0000H, the value of the TDRmn register is loaded to the TCRmn register again and the count operation is continued. By detecting TCRmn = 0000H, INTTMmn is generated and TOMn performs toggle operation. After that, the above operation is repeated.
Operation stop	The TTmn (TTHm1, TTHm3) bit is set to 1. The TTmn (TTHm1, TTHm3) bit automatically returns to 0 because it is a trigger bit.	TEmn (TEHm1, TEHm3), and count operation stops. The TCRmn register holds count value and stops. The TOMn output is not initialized but holds current status.
	The TOEmn bit is cleared to 0 and value is set to the TOMn bit.	The TOMn pin outputs the TOMn bit set level.

Operation is resumed.

(Remark is listed on the next page.)

Figure 6-40. Operation Procedure of Interval Timer/Square Wave Output Function (2/2)

	Software Operation	Hardware Status
TAU stop	To hold the TOMn pin output level Clears the TOMn bit to 0 after the value to be held is set to the port register. →	The TOMn pin output level is held by port function.
	When holding the TOMn pin output level is not necessary Setting not required. ----- The TAUmEN bit of the PER0 register is cleared to 0. →	Power-off status All circuits are initialized and SFR of each channel is also initialized. (The TOMn bit is cleared to 0 and the TOMn pin is set to port mode.)

**Remark** m: Unit number (m = 0, 1), n: Channel number (n = 0 to 7)

### 6.7.2 Operation as external event counter

The timer array unit can be used as an external event counter that counts the number of times the valid input edge (external event) is detected in the TImn pin. When a specified count value is reached, the event counter generates an interrupt. The specified number of counts can be calculated by the following expression.

$$\text{Specified number of counts} = \text{Set value of TDRmn} + 1$$

Timer count register mn (TCRmn) operates as a down counter in the event counter mode.

The TCRmn register loads the value of timer data register mn (TDRmn) by setting any channel start trigger bit (TSMn, TSHm1, TSHm3) of timer channel start register m (TSM) to 1.

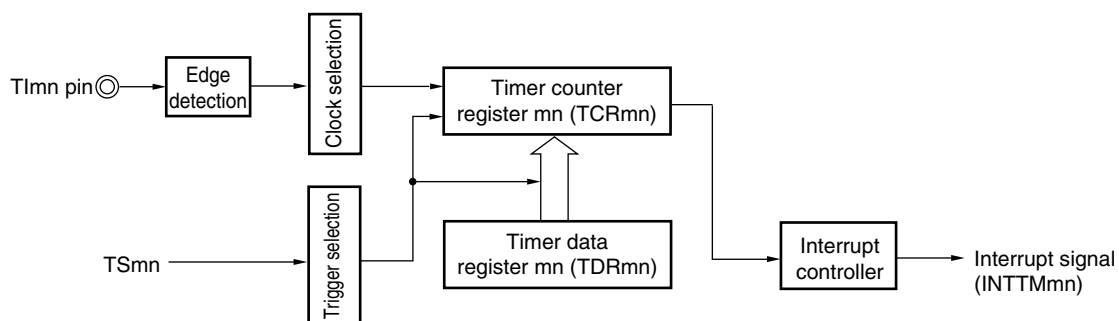
The TCRmn register counts down each time the valid input edge of the TImn pin has been detected. When TCRmn = 0000H, the TCRmn register loads the value of the TDRmn register again, and outputs INTTMmn.

After that, the above operation is repeated.

An irregular waveform that depends on external events is output from the TOmn pin. Stop the output by setting the TOEmn bit of timer output enable register m (TOEm) to 0.

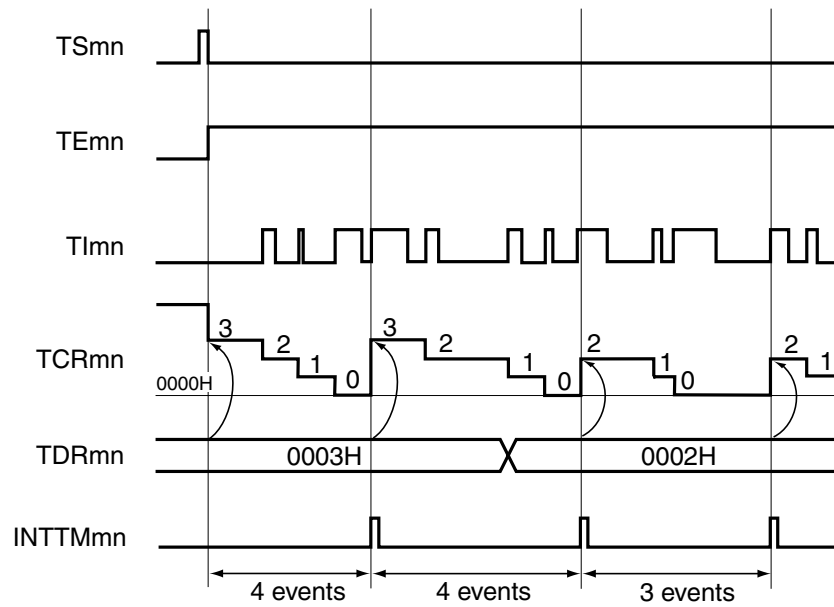
The TDRmn register can be rewritten at any time. The new value of the TDRmn register becomes valid during the next count period.

**Figure 6-41. Block Diagram of Operation as External Event Counter**



**Remark** m: Unit number (m = 0, 1), n: Channel number (n = 0 to 7)

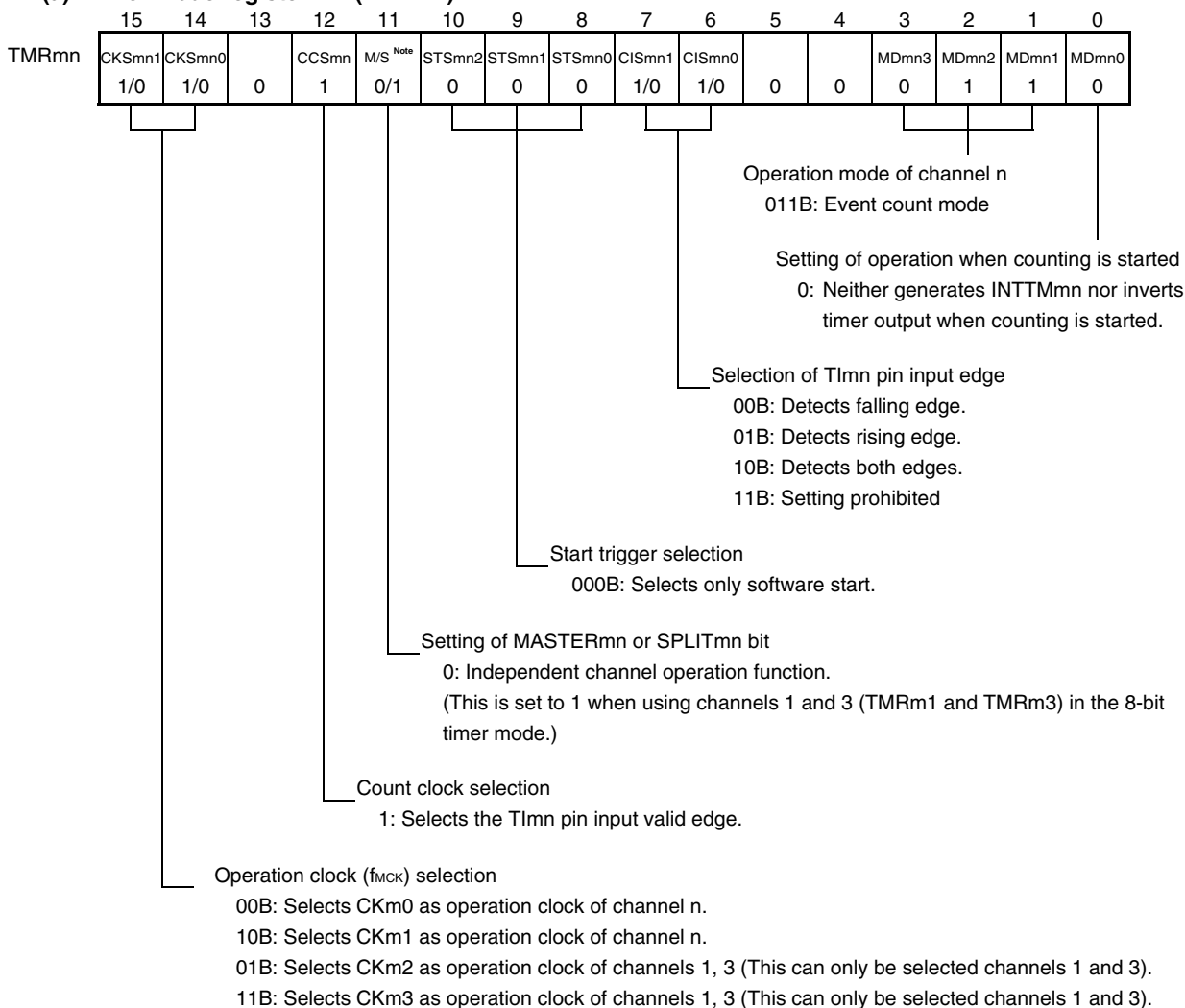
Figure 6-42. Example of Basic Timing of Operation as External Event Counter



- Remarks**
1. m: Unit number (m = 0, 1), n: Channel number (n = 0 to 7)
  2. TSmn: Bit n of timer channel start register m (TSm)
  - TEmn: Bit n of timer channel enable status register m (TEm)
  - TImn: TImn pin input signal
  - TCRmn: Timer count register mn (TCRmn)
  - TDRmn: Timer data register mn (TDRmn)

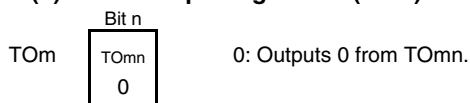
Figure 6-43. Example of Set Contents of Registers in External Event Counter Mode (1/2)

(a) Timer mode register mn (TMRmn)

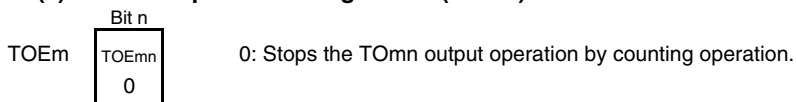


<R>

(b) Timer output register m (TOM)



(c) Timer output enable register m (TOEm)



**Note** TMRm2, TMRm4, TMRm6: MASTERmn bit  
 TMRm1, TMRm3: SPLITmn bit  
 TMRm0, TMRm5, TMRm7: Fixed to 0

<R>

**Remark** m: Unit number (m = 0, 1), n: Channel number (n = 0 to 7)

**Figure 6-43. Example of Set Contents of Registers in External Event Counter Mode (2/2)****(d) Timer output level register m (TOLm)**

TOLm 

Bit n
TOLmn
0

 0: Cleared to 0 when TOMmn = 0 (master channel output mode).

**(e) Timer output mode register m (TOMm)**

TOMm 

Bit n
TOMmn
0

 0: Sets master channel output mode.

**Remark** m: Unit number (m = 0, 1), n: Channel number (n = 0 to 7)



Figure 6-44. Operation Procedure When External Event Counter Function Is Used

	Software Operation	Hardware Status
TAU default setting		Power-off status (Clock supply is stopped and writing to each register is disabled.)
	Sets the TAUmEN bit of peripheral enable register 0 (PER0) to 1.	Power-on status. Each channel stops operating. (Clock supply is started and writing to each register is enabled.)
	Sets timer clock select register m (TPSm). Determines clock frequencies of CKm0 and CKm1 (or CKm2 and CKm3 when using the 8-bit timer mode).	
Channel default setting	Sets timer mode register mn (TMRmn) (determines operation mode of channel). Sets number of counts to timer data register mn (TDRmn). Clears the TOEmn bit of timer output enable register m (TOEm) to 0.	Channel stops operating. (Clock is supplied and some power is consumed.)
Operation start	Sets the TSmn bit to 1. The TSmn bit automatically returns to 0 because it is a trigger bit.	TEmn = 1, and count operation starts. Value of the TDRmn register is loaded to timer count register mn (TCRmn) and detection of the TImn pin input edge is awaited.
During operation	Set value of the TDRmn register can be changed. The TCRmn register can always be read. The TSRmn register is not used. Set values of the TMRmn register, TOMmn, TOLmn, TOmn, and TOEmn bits cannot be changed.	Counter (TCRmn) counts down each time input edge of the TImn pin has been detected. When count value reaches 0000H, the value of the TDRmn register is loaded to the TCRmn register again, and the count operation is continued. By detecting TCRmn = 0000H, the INTTMmn output is generated. After that, the above operation is repeated.
Operation stop	The TTmn bit is set to 1. The TTmn bit automatically returns to 0 because it is a trigger bit.	TEmn = 0, and count operation stops. The TCRmn register holds count value and stops.
TAU stop	The TAUmEN bit of the PER0 register is cleared to 0.	Power-off status All circuits are initialized and SFR of each channel is also initialized.

Operation is resumed.

**Remark** m: Unit number (m = 0, 1), n: Channel number (n = 0 to 7)

### 6.7.3 Operation as frequency divider (channel 0 of unit 0 only)

The timer array unit can be used as a frequency divider that divides a clock input to the TI00 pin and outputs the result from the TO00 pin.

The divided clock frequency output from TO00 can be calculated by the following expression.

- When rising edge/falling edge is selected:  
Divided clock frequency = Input clock frequency / {(Set value of TDR00 + 1) × 2}
- When both edges are selected:  
Divided clock frequency ≅ Input clock frequency / (Set value of TDR00 + 1)

Timer count register 00 (TCR00) operates as a down counter in the interval timer mode.

After the channel start trigger bit (TS00) of timer channel start register 0 (TS0) is set to 1, the TCR00 register loads the value of timer data register 00 (TDR00) when the TI00 valid edge is detected.

If the MD000 bit of timer mode register 00 (TMR00) is 0 at this time, INTTM00 is not output and TO00 is not toggled. If the MD000 bit of timer mode register 00 (TMR00) is 1, INTTM00 is output and TO00 is toggled.

After that, the TCR00 register counts down at the valid edge of the TI00 pin. When TCR00 = 0000H, it toggles TO00. At the same time, the TCR00 register loads the value of the TDR00 register again, and continues counting.

If detection of both the edges of the TI00 pin is selected, the duty factor error of the input clock affects the divided clock period of the TO00 output.

The period of the TO00 output clock includes a sampling error of one period of the operation clock.

$$\text{Clock period of TO00 output} = \text{Ideal TO00 output clock period} \pm \text{Operation clock period (error)}$$

The TDR00 register can be rewritten at any time. The new value of the TDR00 register becomes valid during the next count period.

**Figure 6-45. Block Diagram of Operation as Frequency Divider**

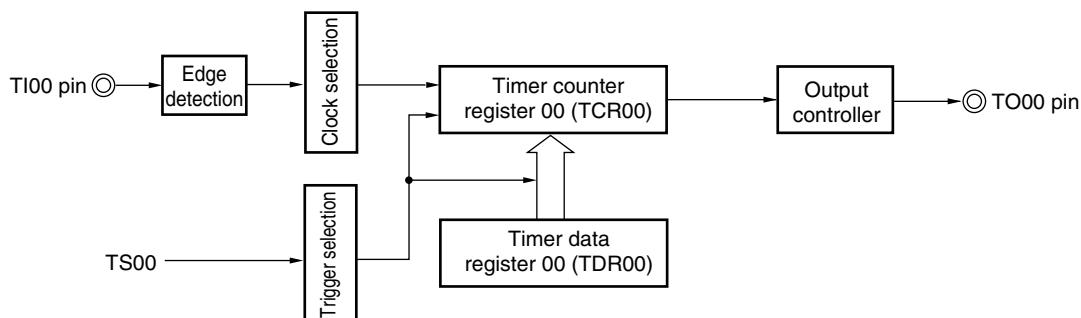
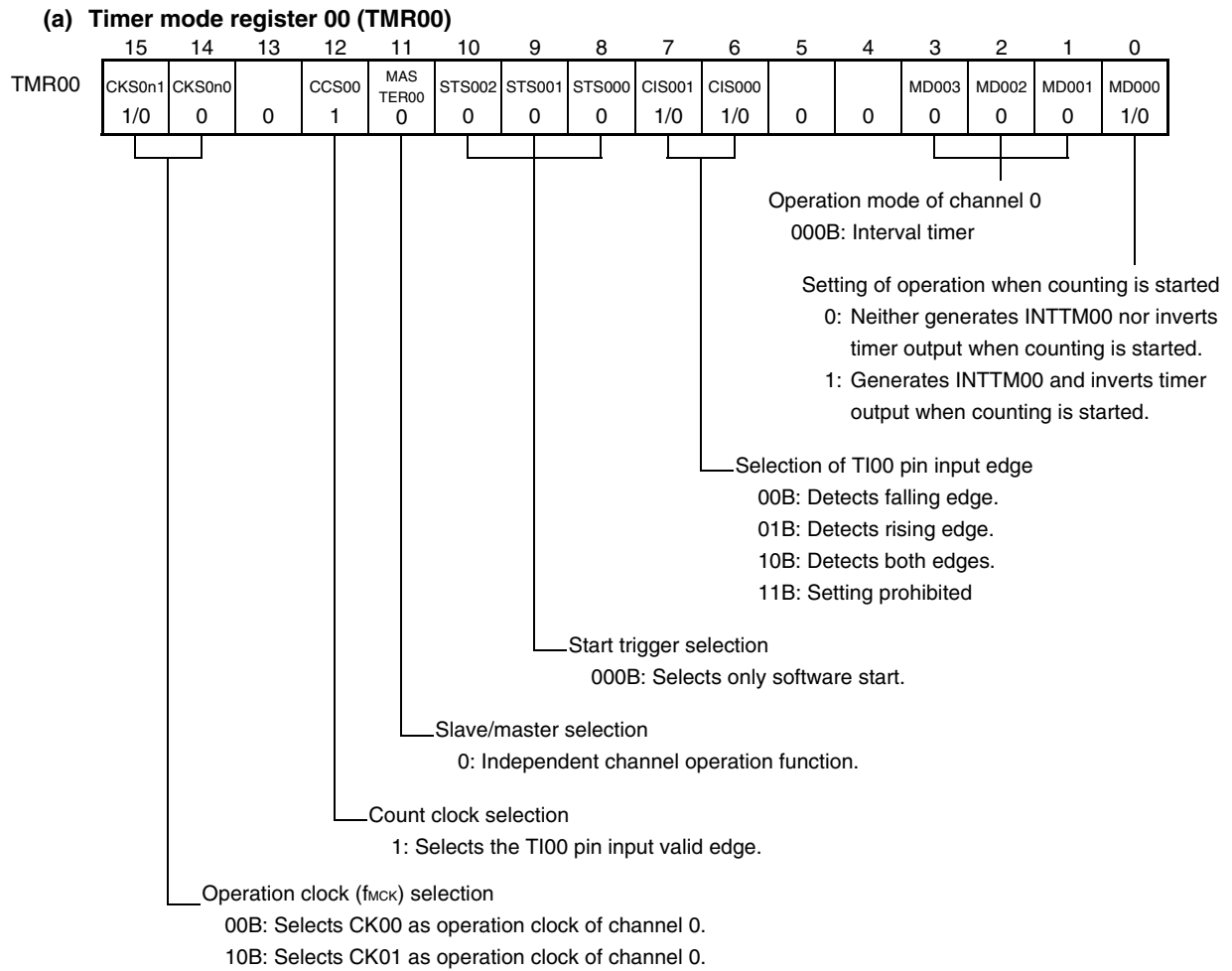




Figure 6-47. Example of Set Contents of Registers During Operation as Frequency Divider



**(b) Timer output register 0 (TO0)**

	Bit 0	
TO0	TO00	0: Outputs 0 from TO00.
	1/0	1: Outputs 1 from TO00.

**(c) Timer output enable register 0 (TOE0)**

	Bit 0	
TOE0	TOE00	0: Stops the TO00 output operation by counting operation.
	1/0	1: Enables the TO00 output operation by counting operation.

**(d) Timer output level register 0 (TOL0)**

	Bit 0	
TOL0	TOL00	0: Cleared to 0 when TOM00 = 0 (master channel output mode)
	0	

**(e) Timer output mode register 0 (TOM0)**

	Bit 0	
TOM0	TOM00	0: Sets master channel output mode.
	0	

Figure 6-48. Operation Procedure When Frequency Divider Function Is Used

	Software Operation	Hardware Status
TAU default setting		Power-off status (Clock supply is stopped and writing to each register is disabled.)
	Sets the TAU0EN bit of peripheral enable register 0 (PER0) to 1.	Power-on status. Each channel stops operating. (Clock supply is started and writing to each register is enabled.)
	Sets timer clock select register 0 (TPS0). Determines clock frequencies of CK00 and CK01.	
Channel default setting	Sets timer mode register 0n (TMR0n) (determines operation mode of channel and selects the detection edge). Sets interval (period) value to timer data register 00 (TDR00).	Channel stops operating. (Clock is supplied and some power is consumed.)
	Clears the TOM00 bit of timer output mode register 0 (TOM0) to 0 (master channel output mode). Clears the TOL00 bit to 0. Sets the TO00 bit and determines default level of the TO00 output.	The TO00 pin goes into Hi-Z output state.  The TO00 default setting level is output when the port mode register is in output mode and the port register is 0.
	Sets the TOE00 bit to 1 and enables operation of TO00. Clears the port register and port mode register to 0.	TO00 does not change because channel stops operating. The TO00 pin outputs the TO00 set level.
Operation start	Sets the TOE00 bit to 1 (only when operation is resumed). Sets the TS00 bit to 1. The TS00 bit automatically returns to 0 because it is a trigger bit.	TE00 = 1, and count operation starts. Value of the TDR00 register is loaded to timer count register 00 (TCR00) at the count clock input. INTTM00 is generated and TO00 performs toggle operation if the MD000 bit of the TMR00 register is 1.
During operation	Set value of the TDR00 register can be changed. The TCR00 register can always be read. The TSR00 register is not used. Set values of the TO0 and TOE0 registers can be changed. Set values of the TMR00 register, TOM00, and TOL00 bits cannot be changed.	Counter (TCR00) counts down. When count value reaches 0000H, the value of the TDR00 register is loaded to the TCR00 register again, and the count operation is continued. By detecting TCR00 = 0000H, INTTM00 is generated and TO00 performs toggle operation. After that, the above operation is repeated.
Operation stop	The TT00 bit is set to 1. The TT00 bit automatically returns to 0 because it is a trigger bit.	TE00 = 0, and count operation stops. The TCR00 register holds count value and stops. The TO00 output is not initialized but holds current status.
	The TOE00 bit is cleared to 0 and value is set to the TO00 bit.	The TO00 pin outputs the TO00 set level.
TAU stop	To hold the TO00 pin output level Clears the TO00 bit to 0 after the value to be held is set to the port register. When holding the TO00 pin output level is not necessary Setting not required.	The TO00 pin output level is held by port function.
	The TAU0EN bit of the PER0 register is cleared to 0.	Power-off status All circuits are initialized and SFR of each channel is also initialized. (The TO00 bit is cleared to 0 and the TO00 pin is set to port mode).

Operation is resumed.

**6.7.4 Operation as input pulse interval measurement**

The count value can be captured at the Tl<sub>mn</sub> valid edge and the interval of the pulse input to Tl<sub>mn</sub> can be measured. The pulse interval can be calculated by the following expression.

$$\text{Tl}_{mn} \text{ input pulse interval} = \text{Period of count clock} \times ((10000\text{H} \times \text{TSR}_{mn}:\text{OVF}) + (\text{Capture value of TDR}_{mn} + 1))$$

**Caution** The Tl<sub>mn</sub> pin input is sampled using the operating clock selected with the CKS<sub>mn</sub> bit of timer mode register mn (TMR<sub>mn</sub>), so an error of up to one operating clock cycle occurs.

Timer count register mn (TCR<sub>mn</sub>) operates as an up counter in the capture mode.

When the channel start trigger bit (TS<sub>mn</sub>) of timer channel start register m (TSM) is set to 1, the TCR<sub>mn</sub> register counts up from 0000H in synchronization with the count clock.

When the Tl<sub>mn</sub> pin input valid edge is detected, the count value of the TCR<sub>mn</sub> register is transferred (captured) to timer data register mn (TDR<sub>mn</sub>) and, at the same time, the TCR<sub>mn</sub> register is cleared to 0000H, and the INTTM<sub>mn</sub> output. If the counter overflows at this time, the OVF bit of timer status register mn (TSR<sub>mn</sub>) is set to 1. If the counter does not overflow, the OVF bit is cleared. After that, the above operation is repeated.

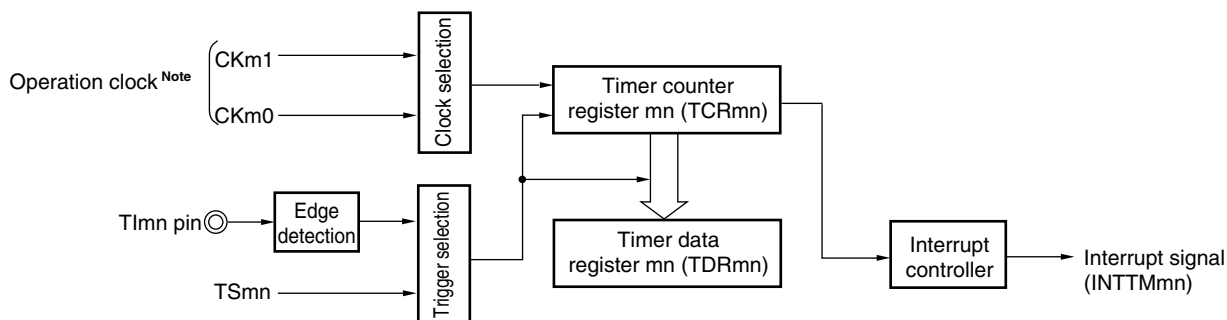
As soon as the count value has been captured to the TDR<sub>mn</sub> register, the OVF bit of the TSR<sub>mn</sub> register is updated depending on whether the counter overflows during the measurement period. Therefore, the overflow status of the captured value can be checked.

If the counter reaches a full count for two or more periods, it is judged to be an overflow occurrence, and the OVF bit of the TSR<sub>mn</sub> register is set to 1. However, a normal interval value cannot be measured for the OVF bit, if two or more overflows occur.

Set the STS<sub>mn</sub>2 to STS<sub>mn</sub>0 bits of the TMR<sub>mn</sub> register to 001B to use the valid edges of Tl<sub>mn</sub> as a start trigger and a capture trigger.

When TE<sub>mn</sub> = 1, a software operation (TS<sub>mn</sub> = 1) can be used as a capture trigger, instead of using the Tl<sub>mn</sub> pin input.

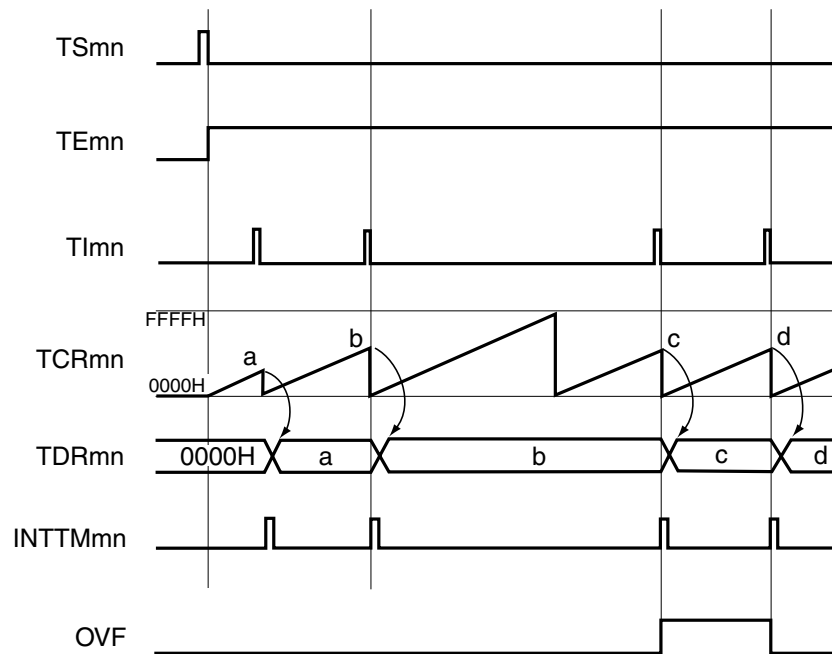
**Figure 6-49. Block Diagram of Operation as Input Pulse Interval Measurement**



<R> **Note** When channels 1 and 3, the clock can be selected from CK<sub>m</sub>0, CK<sub>m</sub>1, CK<sub>m</sub>2 and CK<sub>m</sub>3.

**Remark** m: Unit number (m = 0, 1), n: Channel number (n = 0 to 7)

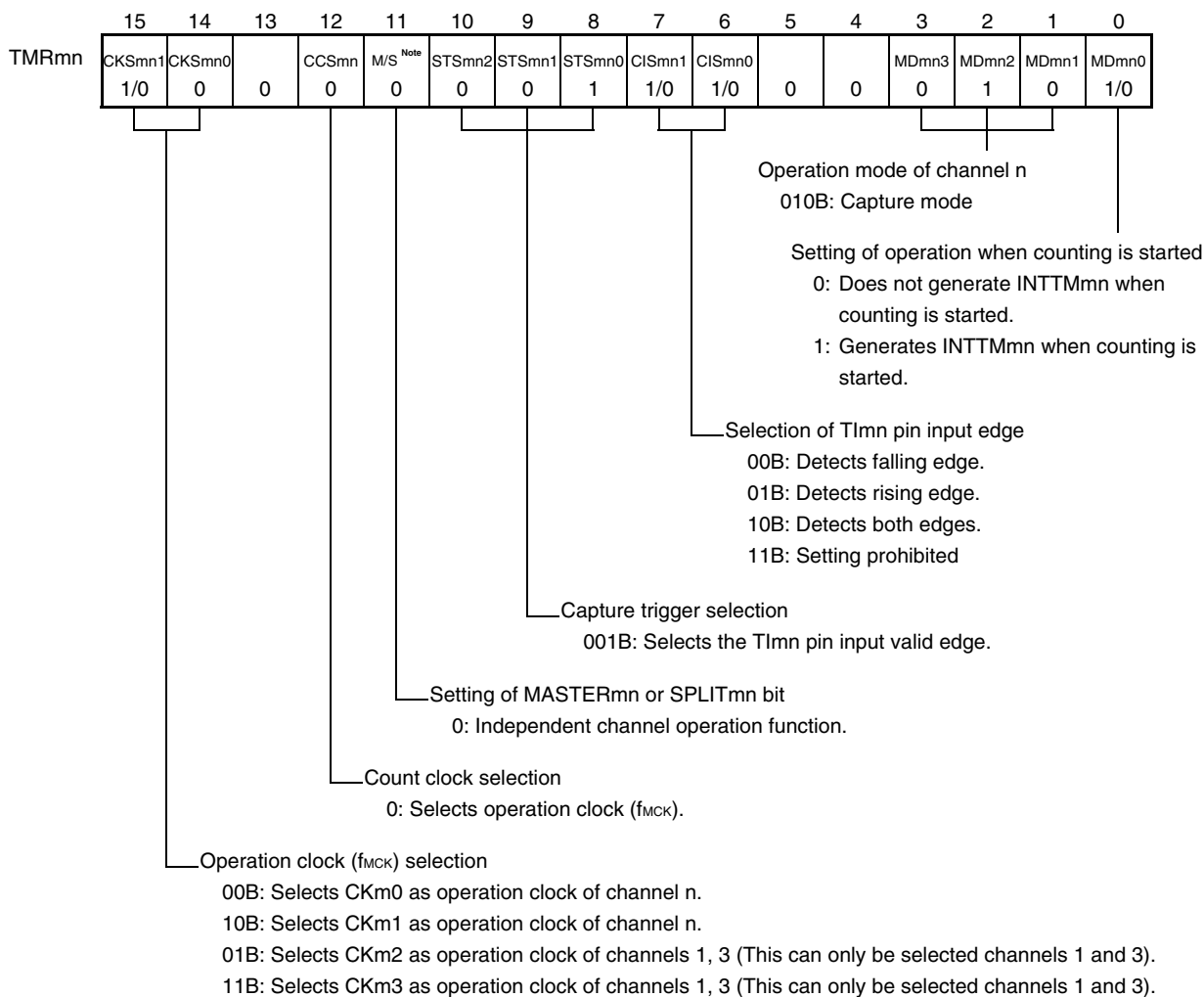
Figure 6-50. Example of Basic Timing of Operation as Input Pulse Interval Measurement (MDmn0 = 0)



- Remarks**
1. m: Unit number (m = 0, 1)n: Channel number (n = 0 to 7)
  2. TSmn: Bit n of timer channel start register m (TSm)  
 TE mn: Bit n of timer channel enable status register m (TEm)  
 TImn: TImn pin input signal  
 TCRmn: Timer count register mn (TCRmn)  
 TDRmn: Timer data register mn (TDRmn)  
 OVF: Bit 0 of timer status register mn (TSRmn)

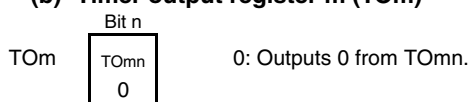
Figure 6-51. Example of Set Contents of Registers to Measure Input Pulse Interval

(a) Timer mode register mn (TMRmn)

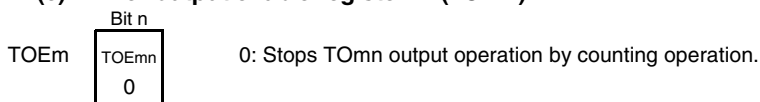


<R>

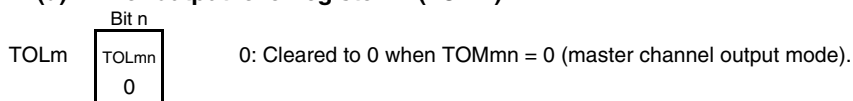
(b) Timer output register m (TOM)



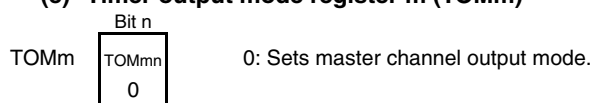
(c) Timer output enable register m (TOEm)



(d) Timer output level register m (TOLm)



(e) Timer output mode register m (TOMm)



**Note** TMRm2, TMRm4, TMRm6: MASTERmn bit  
 TMRm1, TMRm3: SPLITmn bit  
 TMRm0, TMRm5, TMRm7: Fixed to 0

<R>

**Remark** m: Unit number (m = 0, 1), n: Channel number (n = 0 to 7)



Figure 6-52. Operation Procedure When Input Pulse Interval Measurement Function Is Used

	Software Operation	Hardware Status
TAU default setting		Power-off status (Clock supply is stopped and writing to each register is disabled.)
	Sets the TAUmEN bit of peripheral enable register 0 (PER0) to 1.	Power-on status. Each channel stops operating. (Clock supply is started and writing to each register is enabled.)
	Sets timer clock select register m (TPSm). Determines clock frequencies of CKm0 and CKm1.	
Channel default setting	Sets timer mode register mn (TMRmn) (determines operation mode of channel).	Channel stops operating. (Clock is supplied and some power is consumed.)
Operation start	Sets TSmn bit to 1. The TSmn bit automatically returns to 0 because it is a trigger bit.	TEmn = 1, and count operation starts. Timer count register mn (TCRmn) is cleared to 0000H at the count clock input. When the MDmn0 bit of the TMRmn register is 1, INTTMmn is generated.
During operation	Set values of only the CISmn1 and CISmn0 bits of the TMRmn register can be changed. The TDRmn register can always be read. The TCRmn register can always be read. The TSRmn register can always be read. Set values of the TOMmn, TOLmn, TOMn, and TOEmn bits cannot be changed.	Counter (TCRmn) counts up from 0000H. When the TImn pin input valid edge is detected, the count value is transferred (captured) to timer data register mn (TDRmn). At the same time, the TCRmn register is cleared to 0000H, and the INTTMmn signal is generated. If an overflow occurs at this time, the OVF bit of timer status register mn (TSRmn) is set; if an overflow does not occur, the OVF bit is cleared. After that, the above operation is repeated.
Operation stop	The TTmn bit is set to 1. The TTmn bit automatically returns to 0 because it is a trigger bit.	TEmn = 0, and count operation stops. The TCRmn register holds count value and stops. The OVF bit of the TSRmn register is also held.
TAU stop	The TAUmEN bit of the PER0 register is cleared to 0.	Power-off status All circuits are initialized and SFR of each channel is also initialized.

Operation is resumed.

**Remark** m: Unit number (m = 0, 1), n: Channel number (n = 0 to 7)

### 6.7.5 Operation as input signal high-/low-level width measurement

**Caution** When using a channel to implement the LIN-bus, set bit 1 (ISC1) of the input switch control register (ISC) to 1. In the following descriptions, read TImn as RxD2.

By starting counting at one edge of the TImn pin input and capturing the number of counts at another edge, the signal width (high-level width/low-level width) of TImn can be measured. The signal width of TImn can be calculated by the following expression.

$$\text{Signal width of TImn input} = \text{Period of count clock} \times ((10000\text{H} \times \text{TSRmn: OVF}) + (\text{Capture value of TDRmn} + 1))$$

**Caution** The TImn pin input is sampled using the operating clock selected with the CKSmn bit of timer mode register mn (TMRmn), so an error equivalent to one operation clock occurs.

Timer count register mn (TCRmn) operates as an up counter in the capture & one-count mode.

When the channel start trigger bit (TSmn) of timer channel start register m (TSM) is set to 1, the TEmn bit is set to 1 and the TImn pin start edge detection wait status is set.

When the TImn pin input start edge (rising edge of the TImn pin input when the high-level width is to be measured) is detected, the counter counts up from 0000H in synchronization with the count clock. When the valid capture edge (falling edge of the TImn pin input when the high-level width is to be measured) is detected later, the count value is transferred to timer data register mn (TDRmn) and, at the same time, INTTMmn is output. If the counter overflows at this time, the OVF bit of timer status register mn (TSRmn) is set to 1. If the counter does not overflow, the OVF bit is cleared. The TCRmn register stops at the value "value transferred to the TDRmn register + 1", and the TImn pin start edge detection wait status is set. After that, the above operation is repeated.

As soon as the count value has been captured to the TDRmn register, the OVF bit of the TSRmn register is updated depending on whether the counter overflows during the measurement period. Therefore, the overflow status of the captured value can be checked.

If the counter reaches a full count for two or more periods, it is judged to be an overflow occurrence, and the OVF bit of the TSRmn register is set to 1. However, a normal interval value cannot be measured for the OVF bit, if two or more overflows occur.

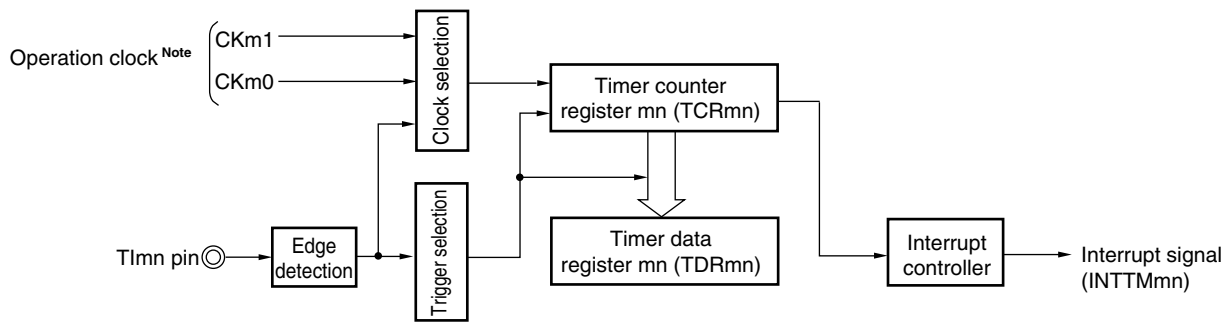
Whether the high-level width or low-level width of the TImn pin is to be measured can be selected by using the CISmn1 and CISmn0 bits of the TMRmn register.

Because this function is used to measure the signal width of the TImn pin input, the TSmn bit cannot be set to 1 while the TEmn bit is 1.

CISmn1, CISmn0 of TMRmn register = 10B: Low-level width is measured.

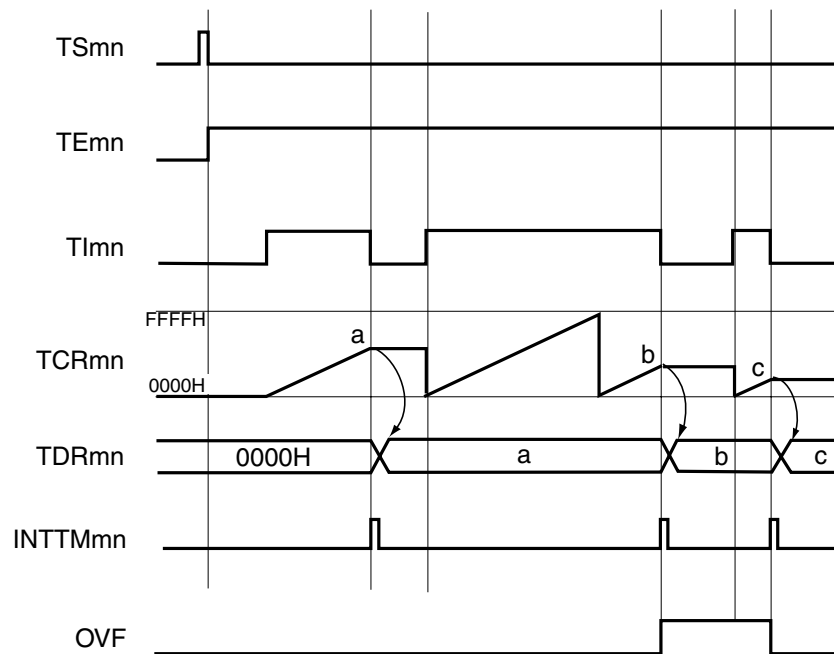
CISmn1, CISmn0 of TMRmn register = 11B: High-level width is measured.

**Figure 6-53. Block Diagram of Operation as Input Signal High-/Low-Level Width Measurement**



<R> **Note** For channels 1 and 3, the clock can be selected from CKm0, CKm1, CKm2 and CKm3.

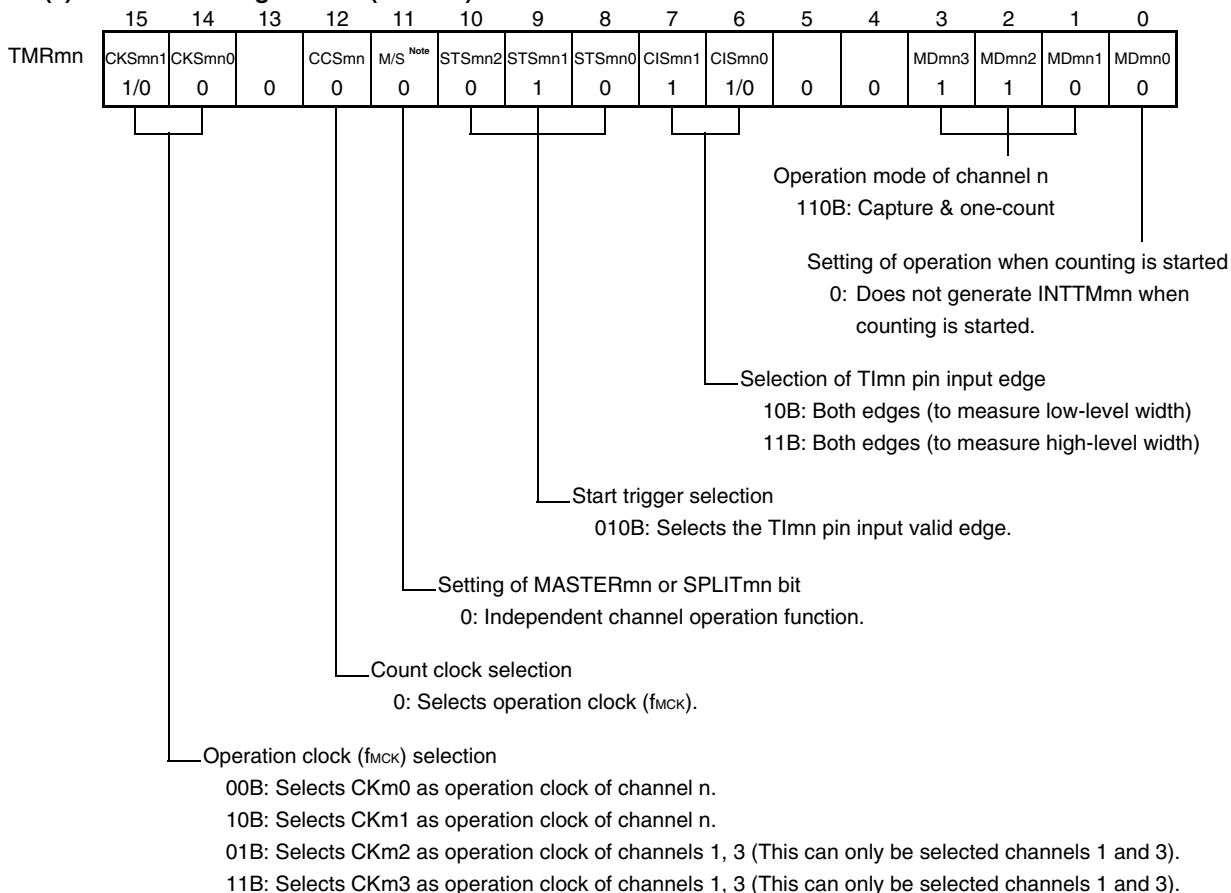
**Figure 6-54. Example of Basic Timing of Operation as Input Signal High-/Low-Level Width Measurement**



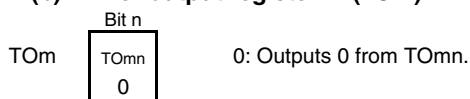
- Remarks**
1. m: Unit number (m = 0, 1), n: Channel number (n = 0 to 7)
  2. TSmn: Bit n of timer channel start register m (TSm)
  - TE mn: Bit n of timer channel enable status register m (TEm)
  - TImn: TImn pin input signal
  - TCRmn: Timer count register mn (TCRmn)
  - TDRmn: Timer data register mn (TDRmn)
  - OVF: Bit 0 of timer status register mn (TSRmn)

Figure 6-55. Example of Set Contents of Registers to Measure Input Signal High-/Low-Level Width

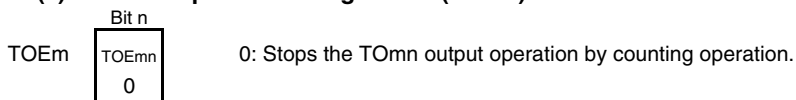
(a) Timer mode register mn (TMRmn)



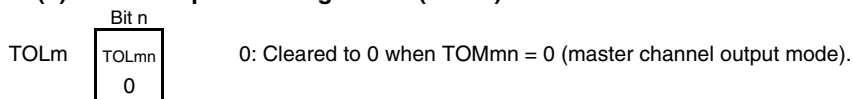
(b) Timer output register m (TOM)



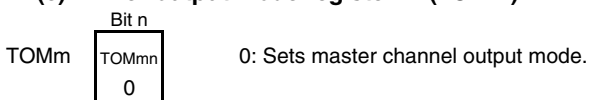
(c) Timer output enable register m (TOEm)



(d) Timer output level register m (TOLm)



(e) Timer output mode register m (TOMm)



**Note** TMRm2, TMRm4, TMRm6: MASTERmn bit  
 TMRm1, TMRm3: SPLITmn bit  
 TMRm0, TMRm5, TMRm7: Fixed to 0

**Remark** m: Unit number (m = 0, 1), n: Channel number (n = 0 to 7)

Figure 6-56. Operation Procedure When Input Signal High-/Low-Level Width Measurement Function Is Used

	Software Operation	Hardware Status
TAU default setting		Power-off status (Clock supply is stopped and writing to each register is disabled.)
	Sets the TAUmEN bit of peripheral enable register 0 (PER0) to 1.	Power-on status. Each channel stops operating. (Clock supply is started and writing to each register is enabled.)
	Sets timer clock select register m (TPSm). Determines clock frequencies of CKm0 and CKm1.	
Channel default setting	Sets timer mode register mn (TMRmn) (determines operation mode of channel). Clears the TOEmn bit to 0 and stops operation of TOMn.	Channel stops operating. (Clock is supplied and some power is consumed.)
Operation start	Sets the TSmn bit to 1. The TSmn bit automatically returns to 0 because it is a trigger bit.	TEmn = 1, and the TImn pin start edge detection wait status is set.
	Detects the TImn pin input count start valid edge.	Clears timer count register mn (TCRmn) to 0000H and starts counting up.
During operation	Set value of the TDRmn register can be changed. The TCRmn register can always be read. The TSRmn register is not used. Set values of the TMRmn register, TOMmn, TOLmn, TOMn, and TOEmn bits cannot be changed.	When the TImn pin start edge is detected, the counter (TCRmn) counts up from 0000H. If a capture edge of the TImn pin is detected, the count value is transferred to timer data register mn (TDRmn) and INTTMmn is generated. If an overflow occurs at this time, the OVF bit of timer status register mn (TSRmn) is set; if an overflow does not occur, the OVF bit is cleared. The TCRmn register stops the count operation until the next TImn pin start edge is detected.
Operation stop	The TTmn bit is set to 1. The TTmn bit automatically returns to 0 because it is a trigger bit.	TEmn = 0, and count operation stops. The TCRmn register holds count value and stops. The OVF bit of the TSRmn register is also held.
TAU stop	The TAUmEN bit of the PER0 register is cleared to 0.	Power-off status All circuits are initialized and SFR of each channel is also initialized.

Operation is resumed.

**Remark** m: Unit number (m = 0, 1), n: Channel number (n = 0 to 7)

**6.7.6 Operation as delay counter**

It is possible to start counting down when the valid edge of the TImn pin input is detected (an external event), and then generate INTTMmn (a timer interrupt) after any specified interval.

<R> It can also generate INTTMmn (timer interrupt) at any interval by making a software set TSmn = 1 and the count down start during the period of TEMn = 1.

The interrupt generation period can be calculated by the following expression.

$$\text{Generation period of INTTMmn (timer interrupt)} = \text{Period of count clock} \times (\text{Set value of TDRmn} + 1)$$

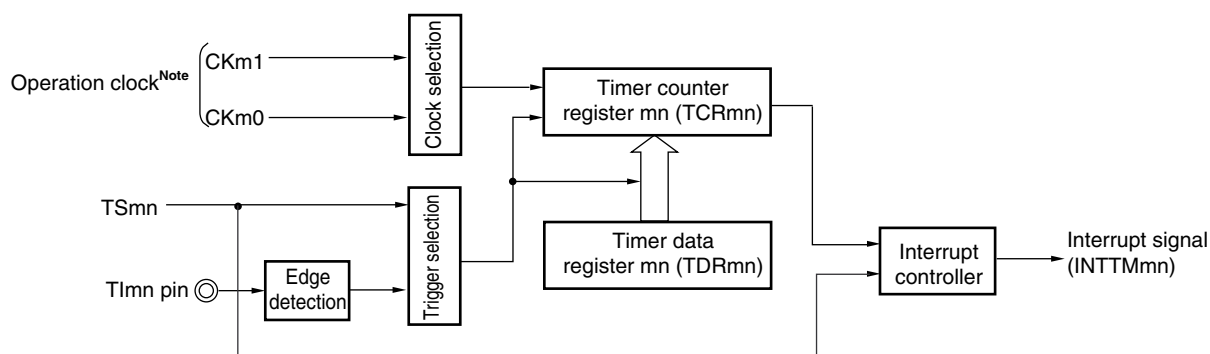
Timer count register mn (TCRmn) operates as a down counter in the one-count mode.

When the channel start trigger bit (TSmn, TSHm1, TSHm3) of timer channel start register m (TSM) is set to 1, the TEMn, TEHm1, TEHm3 bits are set to 1 and the TImn pin input valid edge detection wait status is set.

Timer count register mn (TCRmn) starts operating upon TImn pin input valid edge detection and loads the value of timer data register mn (TDRmn). The TCRmn register counts down from the value of the TDRmn register it has loaded, in synchronization with the count clock. When TCRmn = 0000H, it outputs INTTMmn and stops counting until the next TImn pin input valid edge is detected.

The TDRmn register can be rewritten at any time. The new value of the TDRmn register becomes valid from the next period.

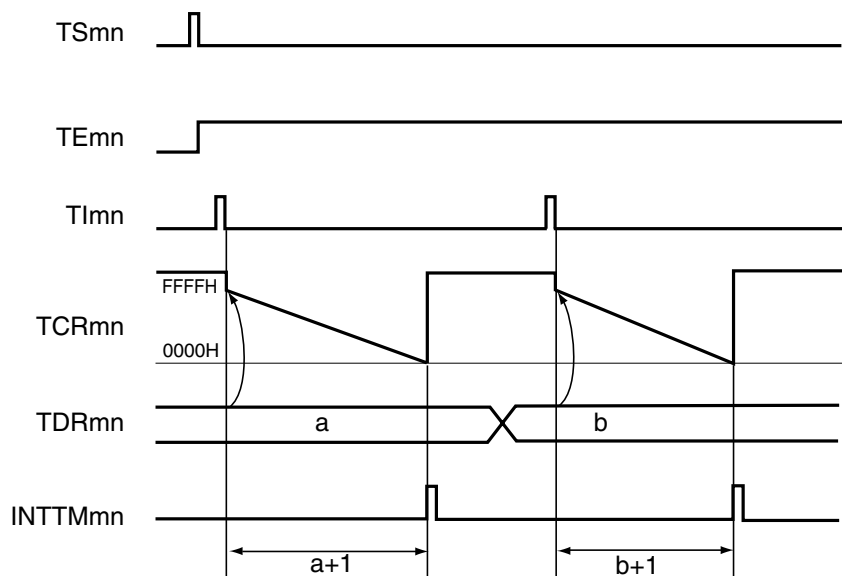
**Figure 6-57. Block Diagram of Operation as Delay Counter**



<R> **Note** For using channels 1 and 3, the clock can be selected from CKm0, CKm1, CKm2 and CKm3.

**Remark** m: Unit number (m = 0, 1), n: Channel number (n = 0 to 7)

Figure 6-58. Example of Basic Timing of Operation as Delay Counter

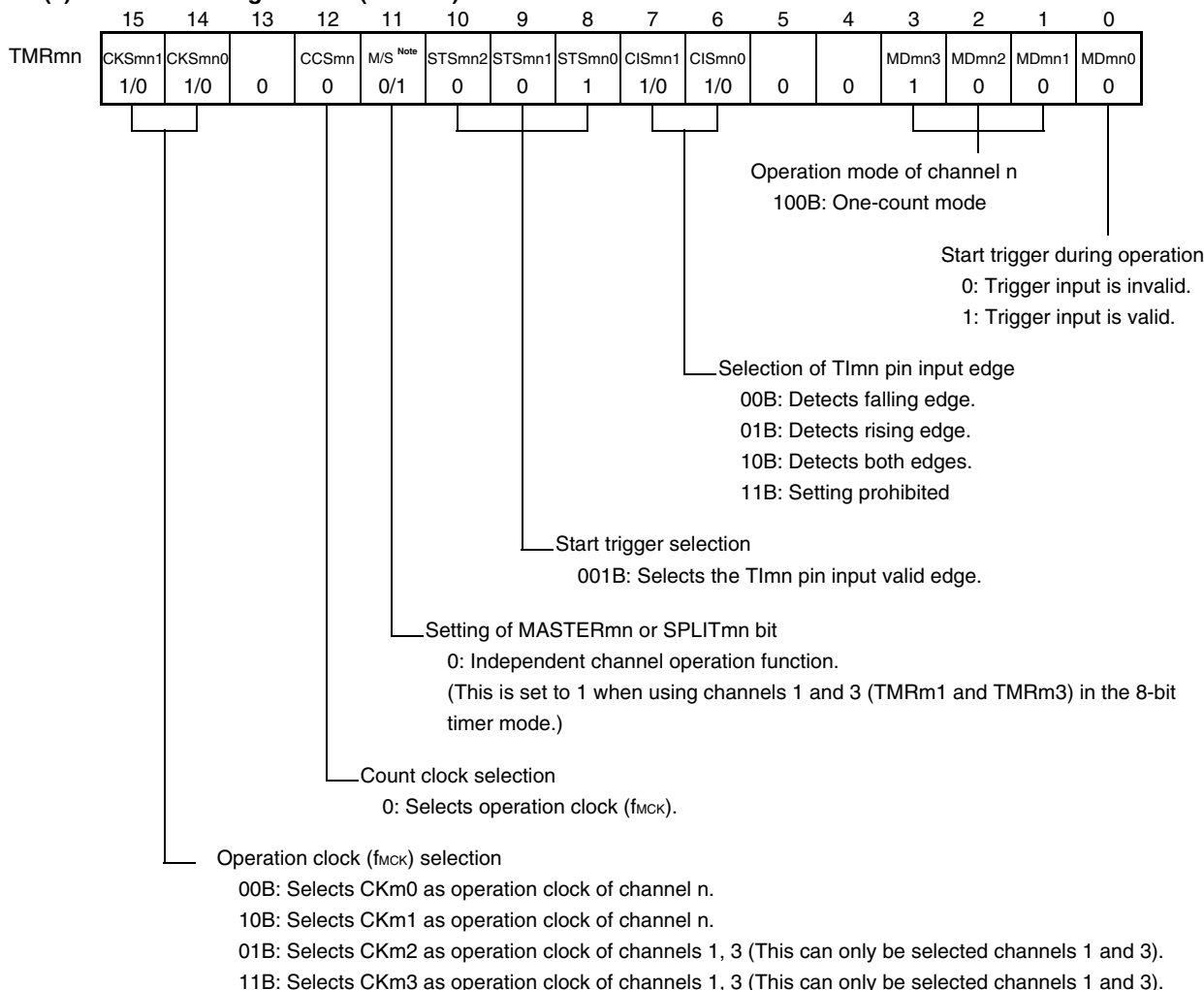


**Remarks 1.** m: Unit number (m = 0, 1), n: Channel number (n = 0 to 7)

2. TSmn: Bit n of timer channel start register m (TSm)
- TE<sub>mn</sub>: Bit n of timer channel enable status register m (TE<sub>m</sub>)
- TI<sub>mn</sub>: TI<sub>mn</sub> pin input signal
- TCR<sub>mn</sub>: Timer count register mn (TCR<sub>mn</sub>)
- TDR<sub>mn</sub>: Timer data register mn (TDR<sub>mn</sub>)

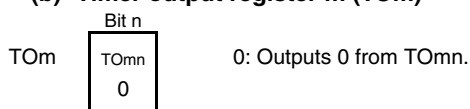
Figure 6-59. Example of Set Contents of Registers to Delay Counter (1/2)

(a) Timer mode register mn (TMRmn)

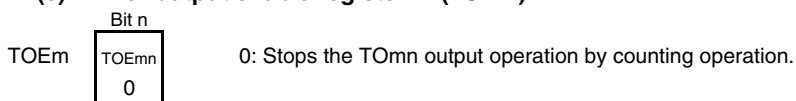


<R>

(b) Timer output register m (TOM)



(c) Timer output enable register m (TOEm)



**Note** TMRm2, TMRm4, TMRm6: MASTERmn bit  
 TMRm1, TMRm3: SPLITmn bit  
 TMRm0, TMRm5, TMRm7: Fixed to 0

<R>

**Remark** m: Unit number (m = 0, 1), n: Channel number (n = 0 to 7)



Figure 6-59. Example of Set Contents of Registers to Delay Counter (2/2)

**(d) Timer output level register m (TOLm)**

TOLm 

Bit n
TOLmn
0

 0: Cleared to 0 when TOMmn = 0 (master channel output mode).

**(e) Timer output mode register m (TOMm)**

TOMm 

Bit n
TOMmn
0

 0: Sets master channel output mode.

**Remark** m: Unit number (m = 0, 1), n: Channel number (n = 0 to 7)

Figure 6-60. Operation Procedure When Delay Counter Function Is Used

	Software Operation	Hardware Status
TAU default setting		Power-off status (Clock supply is stopped and writing to each register is disabled.)
	Sets the TAUmEN bit of peripheral enable register 0 (PER0) to 1.	Power-on status. Each channel stops operating. (Clock supply is started and writing to each register is enabled.)
	Sets timer clock select register m (TPSm). Determines clock frequencies of CKm0 and CKm1 (or CKm2 and CKm3 when using the 8-bit timer mode).	
Channel default setting	Sets timer mode register mn (TMRmn) (determines operation mode of channel). INTTMmn output delay is set to timer data register mn (TDRmn). Clears the TOEmn bit to 0 and stops operation of TOmn.	Channel stops operating. (Clock is supplied and some power is consumed.)
Operation start	Sets the TSmn bit to 1. The TSmn bit automatically returns to 0 because it is a trigger bit.	TEmn = 1, and the TI <sub>mn</sub> pin input valid edge detection wait status is set.
	Detects the TI <sub>mn</sub> pin input valid edge.	Value of the TDRmn register is loaded to the timer count register mn (TCRmn).
During operation	Set value of the TDRmn register can be changed. The TCRmn register can always be read. The TSRmn register is not used.	The counter (TCRmn) counts down. When TCRmn counts down to 0000H, INTTMmn is output, and counting stops (which leaves TCRmn at 0000H) until the next TI <sub>mn</sub> pin input.
Operation stop	The TTmn bit is set to 1. The TTmn bit automatically returns to 0 because it is a trigger bit.	TEmn = 0, and count operation stops. The TCRmn register holds count value and stops.
TAU stop	The TAUmEN bit of the PER0 register is cleared to 0.	Power-off status All circuits are initialized and SFR of each channel is also initialized.

Operation is resumed.

**Remark** m: Unit number (m = 0, 1), n: Channel number (n = 0 to 7)

## 6.8 Simultaneous Channel Operation Function of Timer Array Unit

### 6.8.1 Operation as one-shot pulse output function

By using two channels as a set, a one-shot pulse having any delay pulse width can be generated from the signal input to the TImn pin.

The delay time and pulse width can be calculated by the following expressions.

$\text{Delay time} = \{\text{Set value of TDRmn (master)} + 2\} \times \text{Count clock period}$ $\text{Pulse width} = \{\text{Set value of TDRmp (slave)}\} \times \text{Count clock period}$
---

The master channel operates in the one-count mode and counts the delays. Timer count register mn (TCRmn) of the master channel starts operating upon start trigger detection and loads the value of timer data register mn (TDRmn).

The TCRmn register counts down from the value of the TDRmn register it has loaded, in synchronization with the count clock. When TCRmn = 0000H, it outputs INTTMmn and stops counting until the next start trigger is detected.

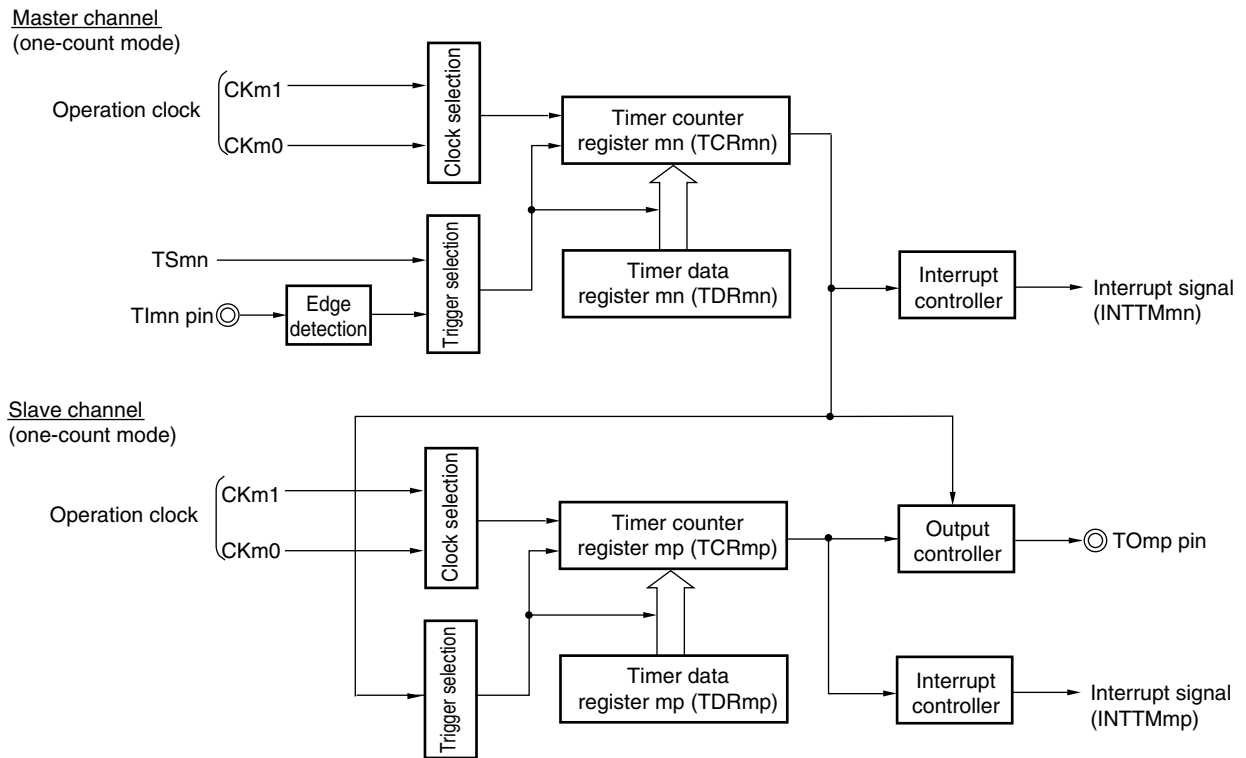
The slave channel operates in the one-count mode and counts the pulse width. The TCRmp register of the slave channel starts operation using INTTMmn of the master channel as a start trigger, and loads the value of the TDRmp register. The TCRmp register counts down from the value of the TDRmp register it has loaded, in synchronization with the count value. When count value = 0000H, it outputs INTTMmp and stops counting until the next start trigger (INTTMmn of the master channel) is detected. The output level of TOmp becomes active one count clock after generation of INTTMmn from the master channel, and inactive when TCRmp = 0000H.

Instead of using the TImn pin input, a one-shot pulse can also be output using the software operation (TSmn = 1) as a start trigger.

**Caution** The timing of loading of timer data register mn (TDRmn) of the master channel is different from that of the TDRmp register of the slave channel. If the TDRmn and TDRmp registers are rewritten during operation, therefore, an illegal waveform is output. Rewrite the TDRmn register after INTTMmn is generated and the TDRmp register after INTTMmp is generated.

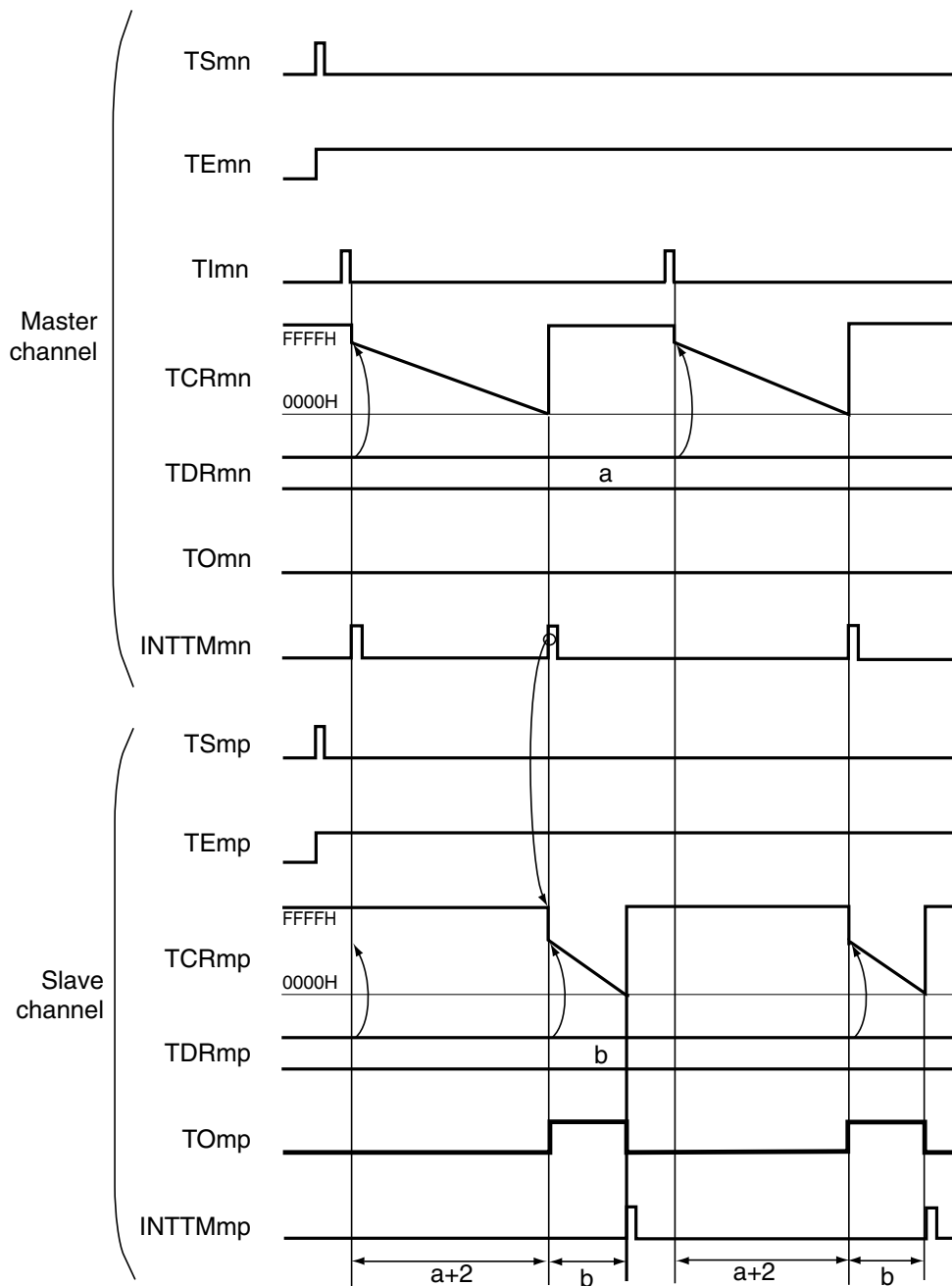
**Remark** m: Unit number (m = 0, 1), n: Channel number (n = 0, 2, 4, 6)  
p: Slave channel number (n < p ≤ 7)

**Figure 6-61. Block Diagram of Operation as One-Shot Pulse Output Function**



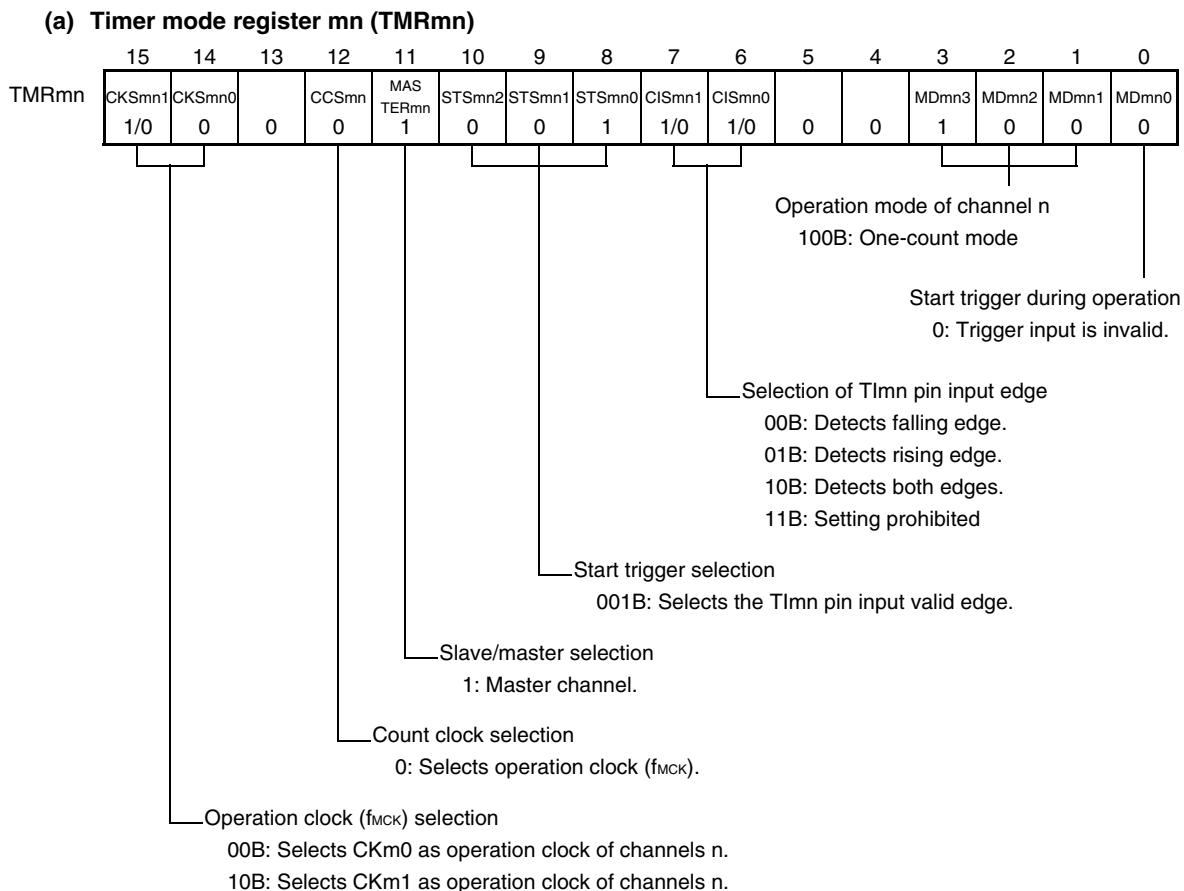
**Remark** m: Unit number (m = 0, 1), n: Channel number (n = 0, 2, 4, 6)  
 p: Slave channel number (n < p ≤ 7)

Figure 6-62. Example of Basic Timing of Operation as One-Shot Pulse Output Function

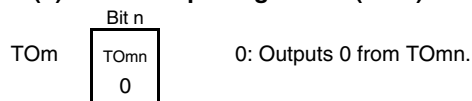


- Remarks**
1. m: Unit number (m = 0, 1), n: Channel number (n = 0, 2, 4, 6)  
 p: Slave channel number (n < p ≤ 7)
  2. TSmn, TSmp: Bit n, p of timer channel start register m (TSM)  
 TEmn, TEmp: Bit n, p of timer channel enable status register m (TEM)  
 TImn, TImp: TImn and TImp pins input signal  
 TCRmn, TCRmp: Timer count registers mn, mp (TCRmn, TCRmp)  
 TDRmn, TDRmp: Timer data registers mn, mp (TDRmn, TDRmp)  
 TOmn, TOmp: TOmn and TOmp pins output signal

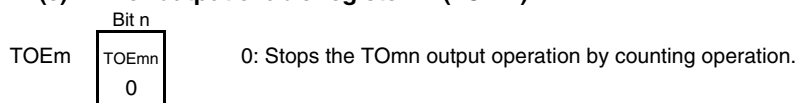
Figure 6-63. Example of Set Contents of Registers When One-Shot Pulse Output Function Is Used (Master Channel)



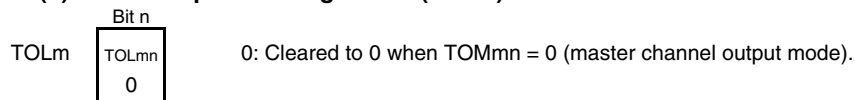
(b) Timer output register m (TOM)



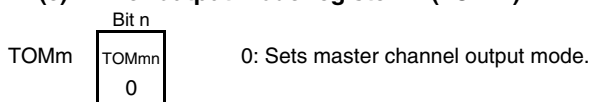
(c) Timer output enable register m (TOEm)



(d) Timer output level register m (TOLm)

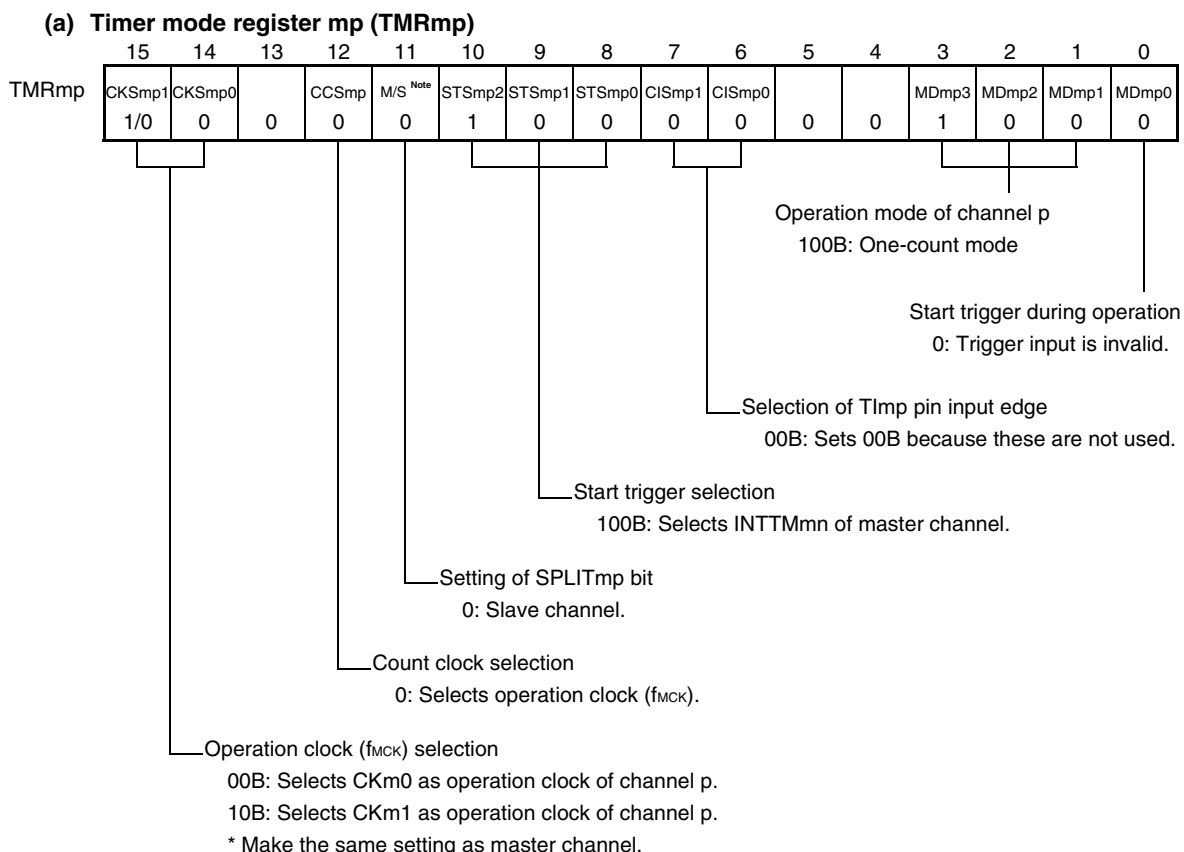


(e) Timer output mode register m (TOMm)



**Remark** m: Unit number (m = 0, 1), n: Channel number (n = 0, 2, 4, 6)

Figure 6-64. Example of Set Contents of Registers When One-Shot Pulse Output Function Is Used (Slave Channel)



(b) Timer output register m (TOM)

TOM	Bit p	0: Outputs 0 from TOmp. 1: Outputs 1 from TOmp.
	TOmp 1/0	

(c) Timer output enable register m (TOEm)

TOEm	Bit p	0: Stops the TOmp output operation by counting operation. 1: Enables the TOmp output operation by counting operation.
	TOEmp 1/0	

(d) Timer output level register m (TOLm)

TOLm	Bit p	0: Positive logic output (active-high) 1: Negative logic output (active-low)
	TOLmp 1/0	

(e) Timer output mode register m (TOMm)

TOMm	Bit p	1: Sets the slave channel output mode.
	TOMmp 1	

<R> **Note** TMRm5, TMRm7: Fixed to 0  
TMRm1, TMRm3: SPLITmp bit

**Remark** m: Unit number (m = 0, 1), n: Channel number (n = 0, 2, 4, 6)  
p: Slave channel number (n < p ≤ 7)

Figure 6-65. Operation Procedure of One-Shot Pulse Output Function (1/2)

	Software Operation	Hardware Status
TAU default setting		Power-off status (Clock supply is stopped and writing to each register is disabled.)
	Sets the TAUmEN bit of peripheral enable registers 0 (PER0) to 1.	Power-on status. Each channel stops operating. (Clock supply is started and writing to each register is enabled.)
	Sets timer clock select register m (TPSm). Determines clock frequencies of CKm0 and CKm1.	
Channel default setting	Sets timer mode register mn, mp (TMRmn, TMRmp) of two channels to be used (determines operation mode of channels). An output delay is set to timer data register mn (TDRmn) of the master channel, and a pulse width is set to the TDRmp register of the slave channel.	Channel stops operating. (Clock is supplied and some power is consumed.)
	Sets slave channel. The TOMmp bit of timer output mode register m (TOMm) is set to 1 (slave channel output mode). Sets the TOLmp bit. Sets the TOmp bit and determines default level of the TOmp output.	The TOmp pin goes into Hi-Z output state.
	Sets the TOEmp bit to 1 and enables operation of TOmp. Clears the port register and port mode register to 0.	The TOmp default setting level is output when the port mode register is in output mode and the port register is 0. TOmp does not change because channel stops operating. The TOmp pin outputs the TOmp set level.

(Note and Remark are listed on the next page.)



Figure 6-65. Operation Procedure of One-Shot Pulse Output Function (2/2)

	Software Operation	Hardware Status
Operation start	<p>Sets the TOEmp bit (slave) to 1 (only when operation is resumed).</p> <p>The TSmn (master) and TSmp (slave) bits of timer channel start register m (TSM) are set to 1 at the same time.</p> <p>The TSmn and TSmp bits automatically return to 0 because they are trigger bits.</p>	<p>The TEMn and TEmP bits are set to 1 and the master channel enters the TImn input edge detection wait status. Counter stops operating.</p>
	<p>Detects the TImn pin input valid edge of master channel.</p>	<p>Master channel starts counting.</p>
During operation	<p>Set values of only the CISmn1 and CISmn0 bits of the TMRmn register can be changed.</p> <p>Set values of the TMRmp, TDRmn, TDRmp registers, TOMmn, TOMmp, TOLmn, and TOLmp bits cannot be changed.</p> <p>The TCRmn and TCRmp registers can always be read.</p> <p>The TSRmn and TSRmp registers are not used.</p> <p>Set values of the TOm and TOEm registers can be changed.</p>	<p>Master channel loads the value of the TDRmn register to timer count register mn (TCRmn) when the TImn pin valid input edge is detected, and the counter starts counting down. When the count value reaches TCRmn = 0000H, the INTTMmn output is generated, and the counter stops until the next valid edge is input to the TImn pin.</p> <p>The slave channel, triggered by INTTMmn of the master channel, loads the value of the TDRmp register to the TCRmp register, and the counter starts counting down. The output level of TOmp becomes active one count clock after generation of INTTMmn from the master channel. It becomes inactive when TCRmp = 0000H, and the counting operation is stopped.</p> <p>After that, the above operation is repeated.</p>
Operation stop	<p>The TTmn (master) and TTmp (slave) bits are set to 1 at the same time.</p> <p>The TTmn and TTmp bits automatically return to 0 because they are trigger bits.</p>	<p>TEMn, TEmP = 0, and count operation stops.</p> <p>The TCRmn and TCRmp registers hold count value and stop.</p> <p>The TOmp output is not initialized but holds current status.</p>
	<p>The TOEmp bit of slave channel is cleared to 0 and value is set to the TOmp bit.</p>	<p>The TOmp pin outputs the TOmp set level.</p>
TAU stop	<p>To hold the TOmp pin output level</p> <p>Clears the TOmp bit to 0 after the value to be held is set to the port register.</p> <p>When holding the TOmp pin output level is not necessary</p> <p>Setting not required.</p>	<p>The TOmp pin output level is held by port function.</p>
	<p>The TAUmEN bit of the PER0 register is cleared to 0.</p>	<p>Power-off status</p> <p>All circuits are initialized and SFR of each channel is also initialized.</p> <p>(The TOmp bit is cleared to 0 and the TOmp pin is set to port mode.)</p>

Operation is resumed.

**Remark** m: Unit number (m = 0, 1), n: Channel number (n = 0, 2, 4, 6)  
 p: Slave channel number (n < p ≤ 7)

### 6.8.2 Operation as PWM function

Two channels can be used as a set to generate a pulse of any period and duty factor.

The period and duty factor of the output pulse can be calculated by the following expressions.

$$\begin{aligned} \text{Pulse period} &= \{\text{Set value of TDRmn (master)} + 1\} \times \text{Count clock period} \\ \text{Duty factor [\%]} &= \{\text{Set value of TDRmp (slave)}\} / \{\text{Set value of TDRmn (master)} + 1\} \times 100 \\ \text{0\% output:} & \quad \text{Set value of TDRmp (slave)} = 0000\text{H} \\ \text{100\% output:} & \quad \text{Set value of TDRmp (slave)} \geq \{\text{Set value of TDRmn (master)} + 1\} \end{aligned}$$

**Remark** The duty factor exceeds 100% if the set value of TDRmp (slave) > (set value of TDRmn (master) + 1), it summarizes to 100% output.

The master channel operates in the interval timer mode. If the channel start trigger bit (TSmn) of timer channel start register m (TSm) is set to 1, an interrupt (INTTMmn) is output, the value set to timer data register mn (TDRmn) is loaded to timer count register mn (TCRmn), and the counter counts down in synchronization with the count clock. When the counter reaches 0000H, INTTMmn is output, the value of the TDRmn register is loaded again to the TCRmn register, and the counter counts down. This operation is repeated until the channel stop trigger bit (TTmn) of timer channel stop register m (TTm) is set to 1.

If two channels are used to output a PWM waveform, the period until the master channel counts down to 0000H is the PWM output (TOmp) cycle.

The slave channel operates in one-count mode. By using INTTMmn from the master channel as a start trigger, the TCRmp register loads the value of the TDRmp register and the counter counts down to 0000H. When the counter reaches 0000H, it outputs INTTMmp and waits until the next start trigger (INTTMmn from the master channel) is generated.

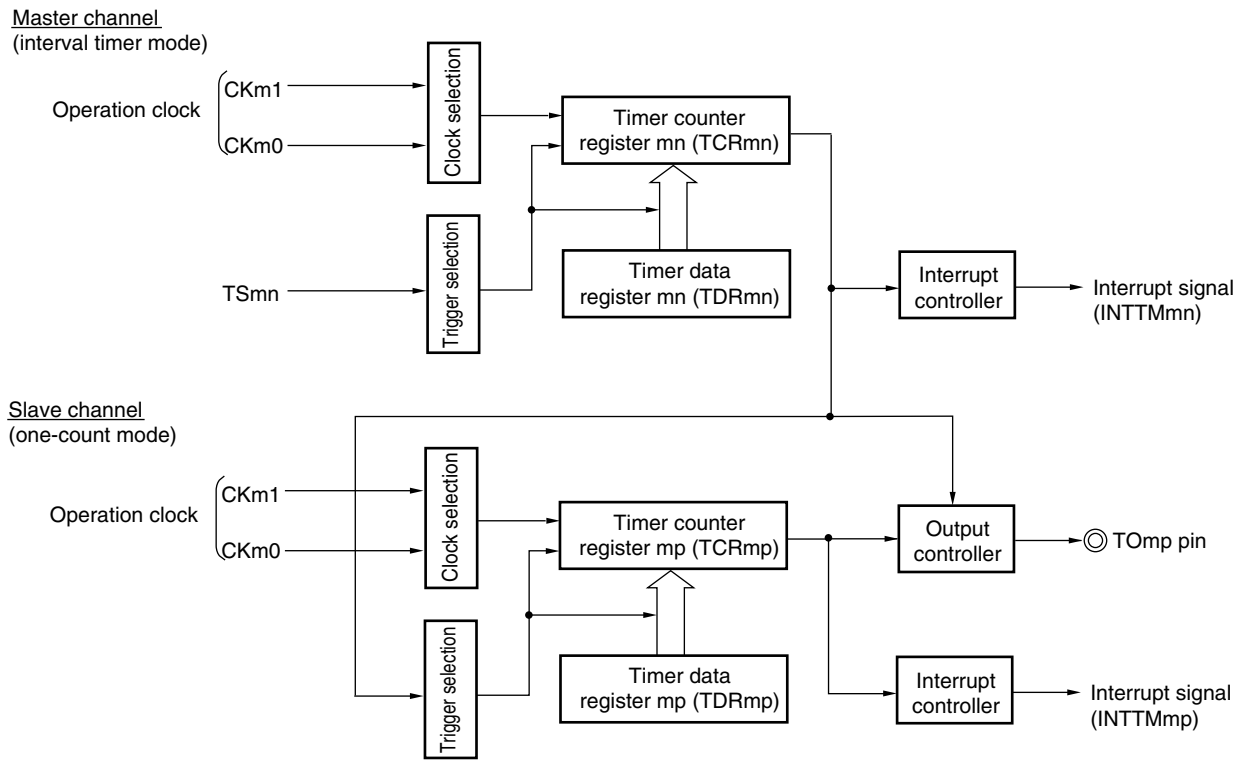
If two channels are used to output a PWM waveform, the period until the slave channel counts down to 0000H is the PWM output (TOmp) duty.

PWM output (TOmp) goes to the active level one clock after the master channel generates INTTMmn and goes to the inactive level when the TCRmp register of the slave channel becomes 0000H.

**Caution** To rewrite both timer data register mn (TDRmn) of the master channel and the TDRmp register of the slave channel, a write access is necessary two times. The timing at which the values of the TDRmn and TDRmp registers are loaded to the TCRmn and TCRmp registers is upon occurrence of INTTMmn of the master channel. Thus, when rewriting is performed split before and after occurrence of INTTMmn of the master channel, the TOmp pin cannot output the expected waveform. To rewrite both the TDRmn register of the master and the TDRmp register of the slave, therefore, be sure to rewrite both the registers immediately after INTTMmn is generated from the master channel.

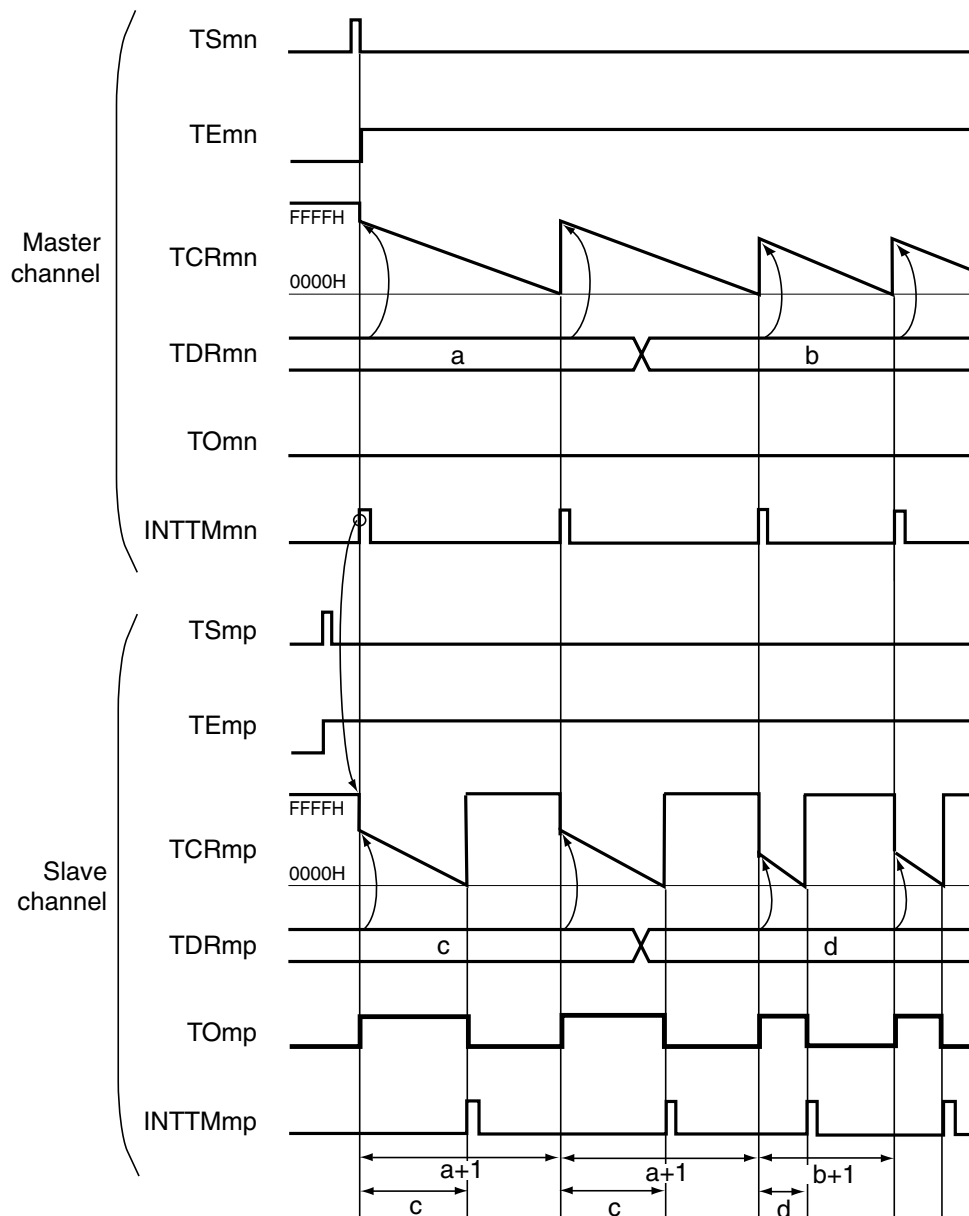
**Remark** m: Unit number (m = 0, 1), n: Channel number (n = 0, 2, 4, 6)  
p: Slave channel number (n < p ≤ 7)

Figure 6-66. Block Diagram of Operation as PWM Function



**Remark** m: Unit number (m = 0, 1), n: Channel number (n = 0, 2, 4, 6)  
 p: Slave channel number (n < p ≤ 7)

Figure 6-67. Example of Basic Timing of Operation as PWM Function

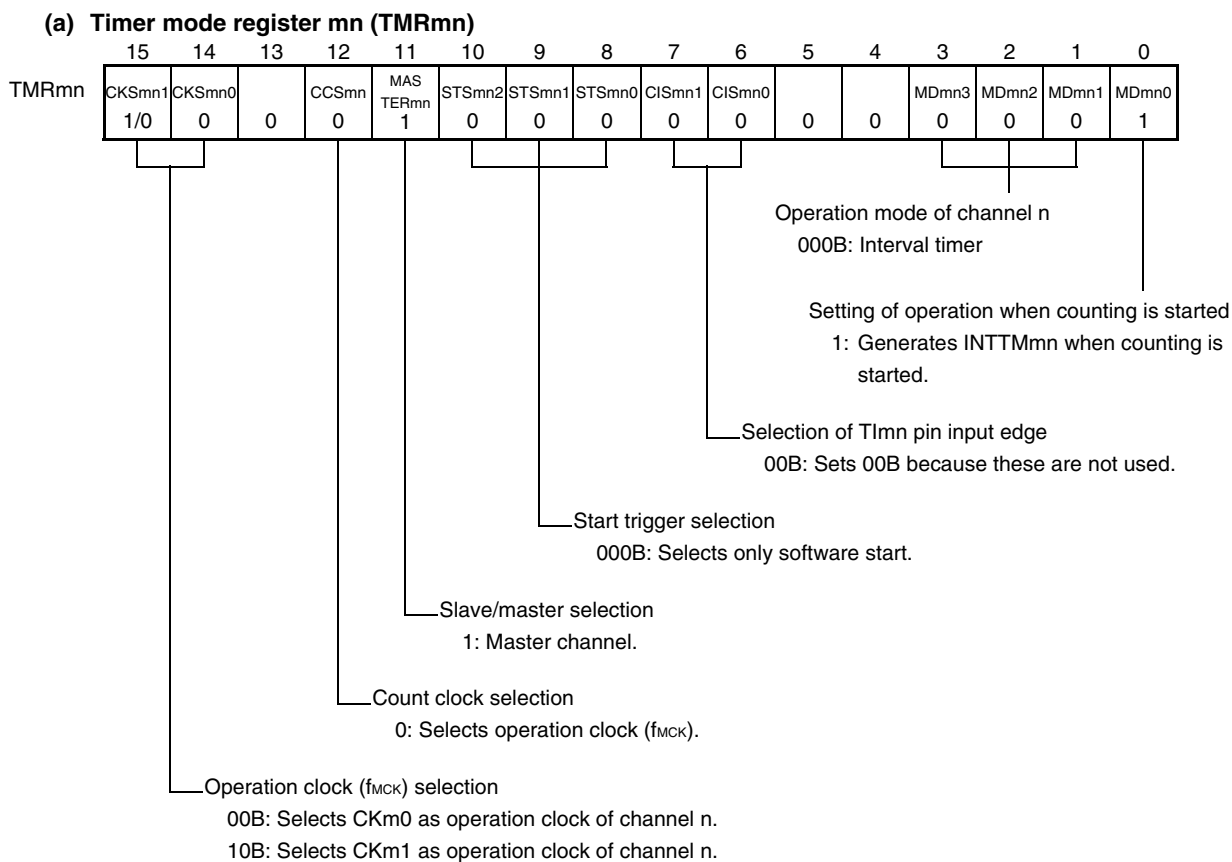


**Remark 1.** m: Unit number (m = 0, 1), n: Channel number (n = 0, 2, 4, 6)

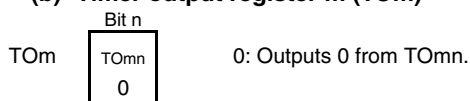
p: Slave channel number (n < p ≤ 7)

2. TSmn, TSmp: Bit n, p of timer channel start register m (TSm)
- TEmn, TEmp: Bit n, p of timer channel enable status register m (TEm)
- TCRmn, TCRmp: Timer count registers mn, mp (TCRmn, TCRmp)
- TDRmn, TDRmp: Timer data registers mn, mp (TDRmn, TDRmp)
- TOmn, TOmp: TOmn and TOmp pins output signal

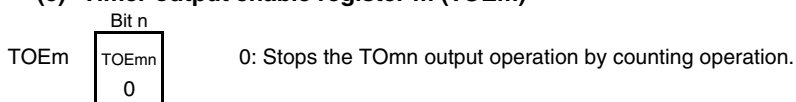
Figure 6-68. Example of Set Contents of Registers When PWM Function (Master Channel) Is Used



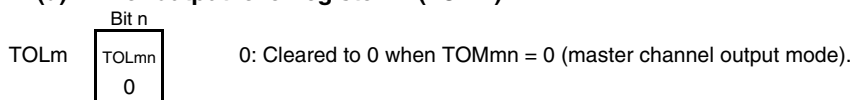
(b) Timer output register m (TOM)



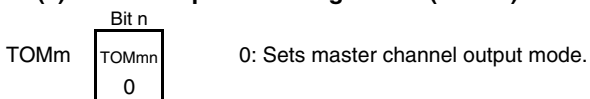
(c) Timer output enable register m (TOEm)



(d) Timer output level register m (TOLm)

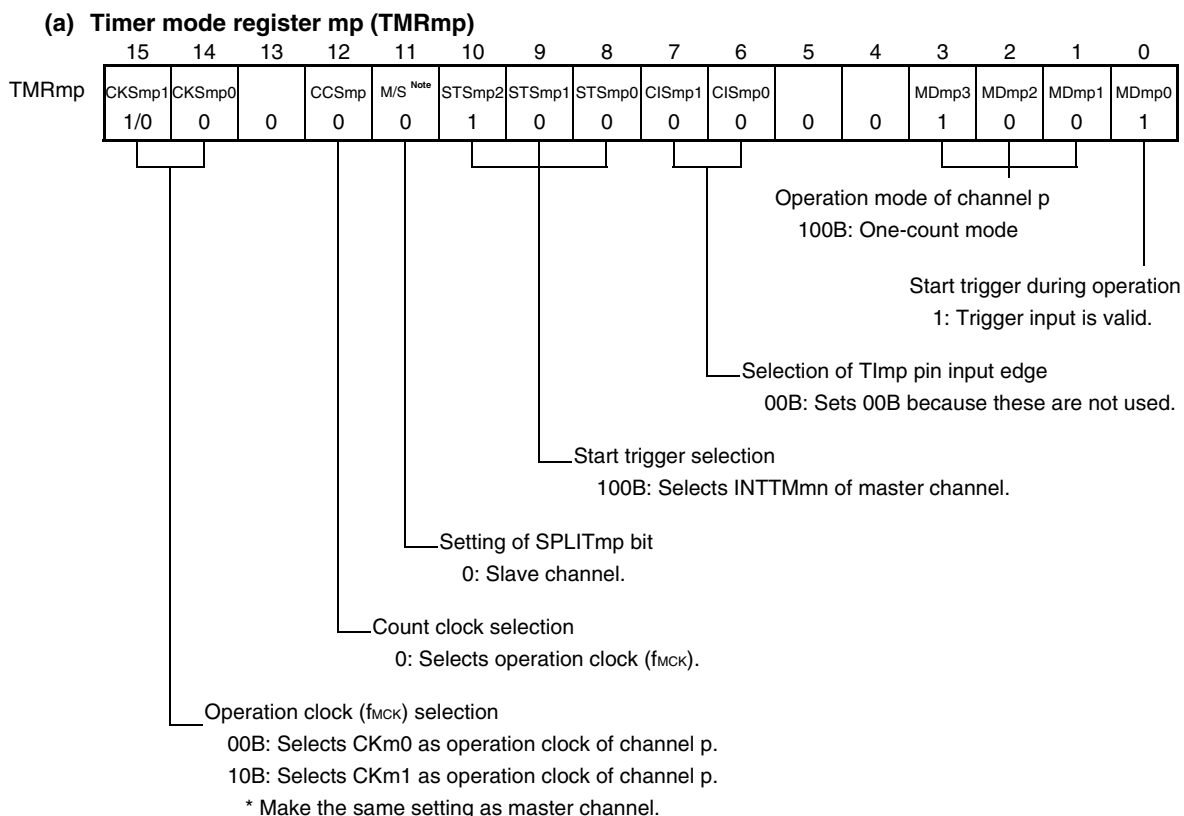


(e) Timer output mode register m (TOMm)

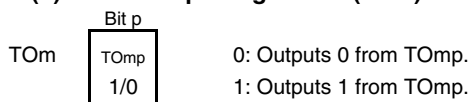


**Remark** m: Unit number (m = 0, 1), n: Channel number (n = 0, 2, 4, 6)

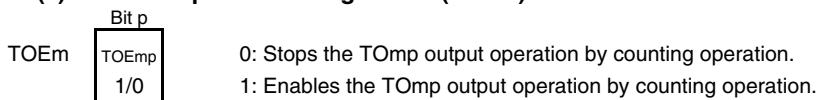
Figure 6-69. Example of Set Contents of Registers When PWM Function (Slave Channel) Is Used



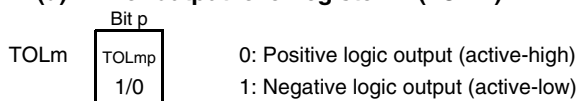
(b) Timer output register m (TOM)



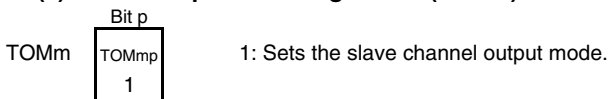
(c) Timer output enable register m (TOEm)



(d) Timer output level register m (TOLm)



(e) Timer output mode register m (TOMm)



<R> **Note** TMRm5, TMRm7: Fixed to 0  
TMRm1, TMRm3: SPLITmp bit

**Remark** m: Unit number (m = 0, 1), n: Channel number (n = 0, 2, 4, 6)  
p: Slave channel number (n < p ≤ 7)

Figure 6-70. Operation Procedure When PWM Function Is Used (1/2)

	Software Operation	Hardware Status
TAU default setting		Power-off status (Clock supply is stopped and writing to each register is disabled.)
	Sets the TAUmEN bit of peripheral enable register 0 (PER0) to 1. →	Power-on status. Each channel stops operating. (Clock supply is started and writing to each register is enabled.)
	Sets timer clock select register m (TPSm). Determines clock frequencies of CKm0 and CKm1.	
Channel default setting	Sets timer mode registers mn, mp (TMRmn, TMRmp) of two channels to be used (determines operation mode of channels). An interval (period) value is set to timer data register mn (TDRmn) of the master channel, and a duty factor is set to the TDRmp register of the slave channel.	Channel stops operating. (Clock is supplied and some power is consumed.)
	Sets slave channel. The TOMmp bit of timer output mode register m (TOMm) is set to 1 (slave channel output mode). Sets the TOLmp bit. Sets the TOmp bit and determines default level of the TOmp output. →  Sets the TOEmp bit to 1 and enables operation of TOmp. → Clears the port register and port mode register to 0. →	The TOmp pin goes into Hi-Z output state.    The TOmp default setting level is output when the port mode register is in output mode and the port register is 0. TOmp does not change because channel stops operating. The TOmp pin outputs the TOmp set level.

(Note and Remark are listed on the next page.)

Figure 6-70. Operation Procedure When PWM Function Is Used (2/2)

	Software Operation	Hardware Status
Operation is resumed.	Operation start Sets the TOEmp bit (slave) to 1 (only when operation is resumed). The TSmn (master) and TSmp (slave) bits of timer channel start register m (TSM) are set to 1 at the same time. The TSmn and TSmp bits automatically return to 0 because they are trigger bits.	TEMn = 1, TEmP = 1 When the master channel starts counting, INTTMmn is generated. Triggered by this interrupt, the slave channel also starts counting.
	During operation Set values of the TMRmn and TMRmp registers, TOMmn, TOMmp, TOLmn, and TOLmp bits cannot be changed. Set values of the TDRmn and TDRmp registers can be changed after INTTMmn of the master channel is generated. The TCRmn and TCRmp registers can always be read. The TSRmn and TSRmp registers are not used.	The counter of the master channel loads the TDRmn register value to timer count register mn (TCRmn), and counts down. When the count value reaches TCRmn = 0000H, INTTMmn output is generated. At the same time, the value of the TDRmn register is loaded to the TCRmn register, and the counter starts counting down again. At the slave channel, the value of the TDRmp register is loaded to the TCRmp register, triggered by INTTMmn of the master channel, and the counter starts counting down. The output level of TOmp becomes active one count clock after generation of the INTTMmn output from the master channel. It becomes inactive when TCRmp = 0000H, and the counting operation is stopped. After that, the above operation is repeated.
	Operation stop The TTmn (master) and TTmp (slave) bits are set to 1 at the same time. The TTmn and TTmp bits automatically return to 0 because they are trigger bits.	TEMn, TEmP = 0, and count operation stops. The TCRmn and TCRmp registers hold count value and stop. The TOmp output is not initialized but holds current status.
	The TOEmp bit of slave channel is cleared to 0 and value is set to the TOmp bit.	The TOmp pin outputs the TOmp set level.
TAU stop To hold the TOmp pin output level Clears the TOmp bit to 0 after the value to be held is set to the port register. When holding the TOmp pin output level is not necessary Setting not required.	The TOmp pin output level is held by port function.	
The TAUmEN bit of the PER0 register is cleared to 0.	Power-off status All circuits are initialized and SFR of each channel is also initialized. (The TOmp bit is cleared to 0 and the TOmp pin is set to port mode.)	

**Remark** m: Unit number (m = 0, 1), n: Channel number (n = 0, 2, 4, 6)  
 p: Slave channel number (n < p ≤ 7)



### 6.8.3 Operation as multiple PWM output function

By extending the PWM function and using multiple slave channels, many PWM waveforms with different duty values can be output.

For example, when using two slave channels, the period and duty factor of an output pulse can be calculated by the following expressions.

$$\begin{aligned} \text{Pulse period} &= \{\text{Set value of TDRmn (master)} + 1\} \times \text{Count clock period} \\ \text{Duty factor 1 [\%]} &= \{\text{Set value of TDRmp (slave 1)}\} / \{\text{Set value of TDRmn (master)} + 1\} \times 100 \\ \text{Duty factor 2 [\%]} &= \{\text{Set value of TDRmq (slave 2)}\} / \{\text{Set value of TDRmn (master)} + 1\} \times 100 \end{aligned}$$

**Remark** Although the duty factor exceeds 100% if the set value of TDRmp (slave 1) > {set value of TDRmn (master) + 1} or if the {set value of TDRmq (slave 2)} > {set value of TDRmn (master) + 1}, it is summarized into 100% output.

Timer count register mn (TCRmn) of the master channel operates in the interval timer mode and counts the periods.

The TCRmp register of the slave channel 1 operates in one-count mode, counts the duty factor, and outputs a PWM waveform from the TOmp pin. The TCRmp register loads the value of timer data register mp (TDRmp), using INTTMmn of the master channel as a start trigger, and starts counting down. When TCRmp = 0000H, TCRmp outputs INTTMmp and stops counting until the next start trigger (INTTMmn of the master channel) has been input. The output level of TOmp becomes active one count clock after generation of INTTMmn from the master channel, and inactive when TCRmp = 0000H.

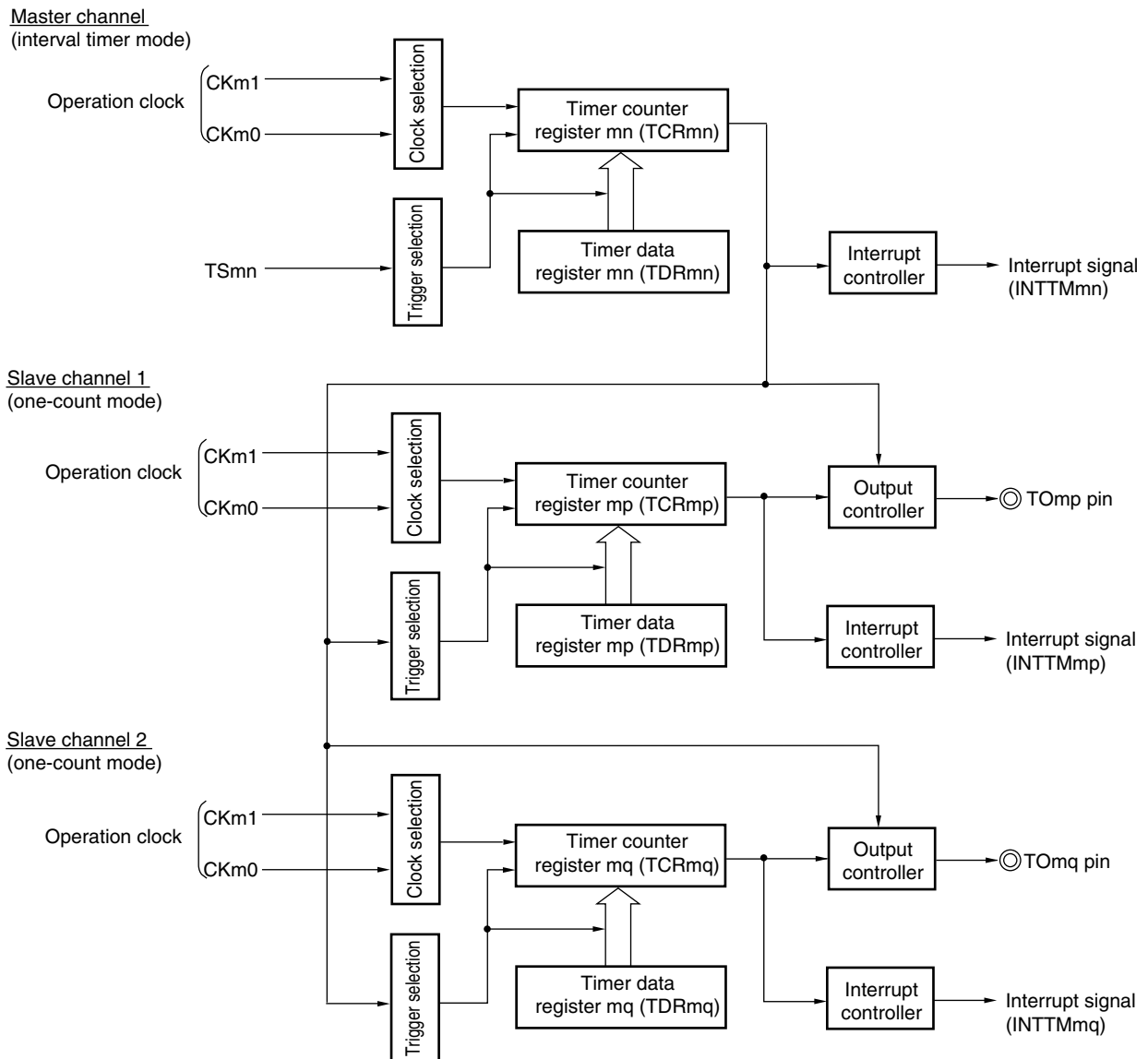
In the same way as the TCRmp register of the slave channel 1, the TCRmq register of the slave channel 2 operates in one-count mode, counts the duty factor, and outputs a PWM waveform from the TOMq pin. The TCRmq register loads the value of the TDRmq register, using INTTMmn of the master channel as a start trigger, and starts counting down. When TCRmq = 0000H, the TCRmq register outputs INTTMmq and stops counting until the next start trigger (INTTMmn of the master channel) has been input. The output level of TOMq becomes active one count clock after generation of INTTMmn from the master channel, and inactive when TCRmq = 0000H.

When channel 0 is used as the master channel as above, up to seven types of PWM signals can be output at the same time.

**Caution** To rewrite both timer data register mn (TDRmn) of the master channel and the TDRmp register of the slave channel 1, write access is necessary at least twice. Since the values of the TDRmn and TDRmp registers are loaded to the TCRmn and TCRmp registers after INTTMmn is generated from the master channel, if rewriting is performed separately before and after generation of INTTMmn from the master channel, the TOmp pin cannot output the expected waveform. To rewrite both the TDRmn register of the master and the TDRmp register of the slave, be sure to rewrite both the registers immediately after INTTMmn is generated from the master channel (This applies also to the TDRmq register of the slave channel 2).

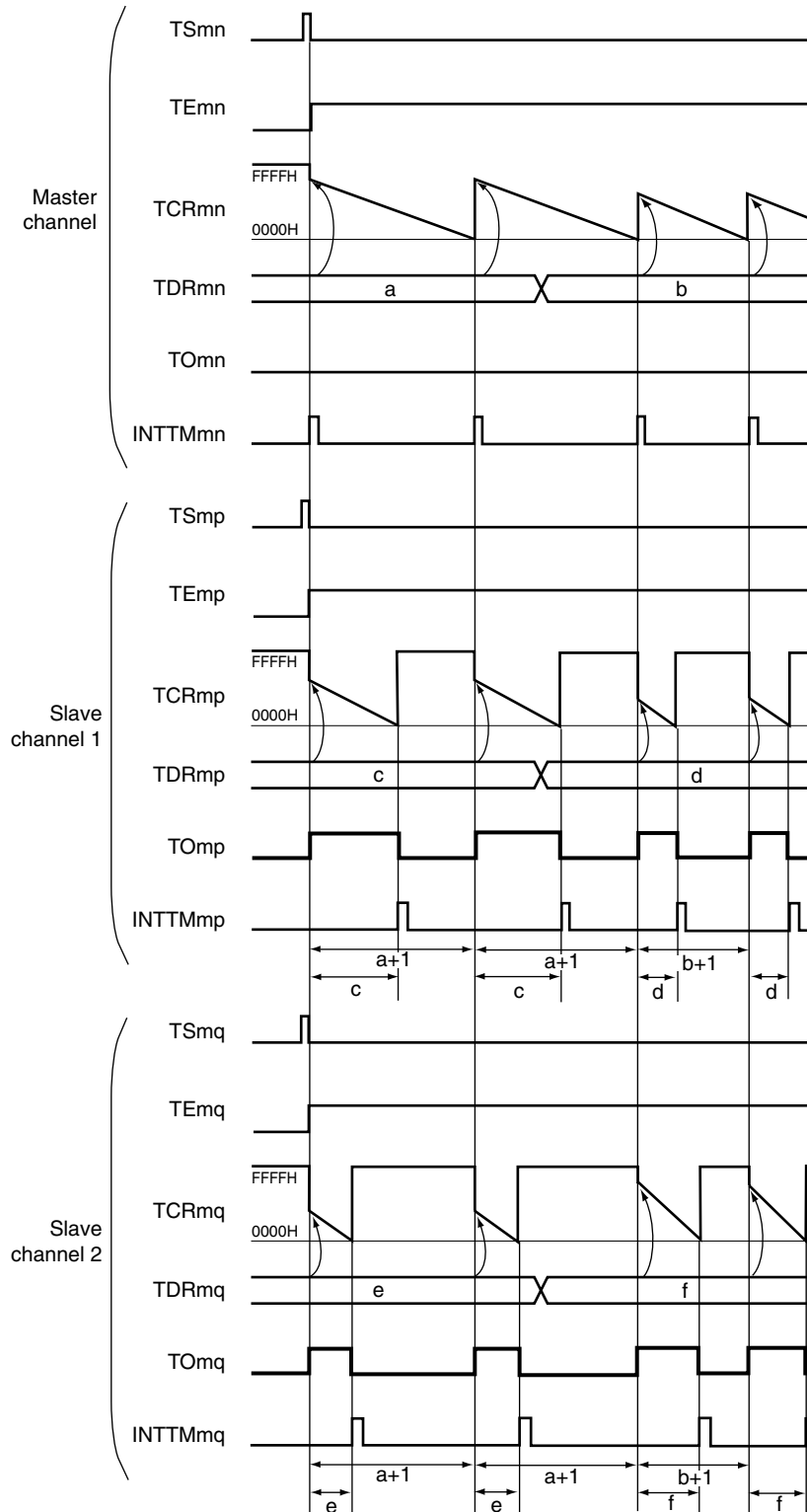
**Remark** m: Unit number (m = 0, 1), n: Channel number (n = 0, 2, 4)  
 p: Slave channel number 1, q: Slave channel number 2  
 n < p < q ≤ 7 (Where p and q are consecutive integers greater than n)

Figure 6-71. Block Diagram of Operation as Multiple PWM Output Function (output two types of PWMs)



**Remark** m: Unit number (m = 0, 1), n: Channel number (n = 0, 2, 4)  
 p: Slave channel number 1, q: Slave channel number 2  
 n < p < q ≤ 7 (Where p and q are consecutive integers greater than n)

**Figure 6-72. Example of Basic Timing of Operation as Multiple PWM Output Function (Output two types of PWMs) (1/2)**

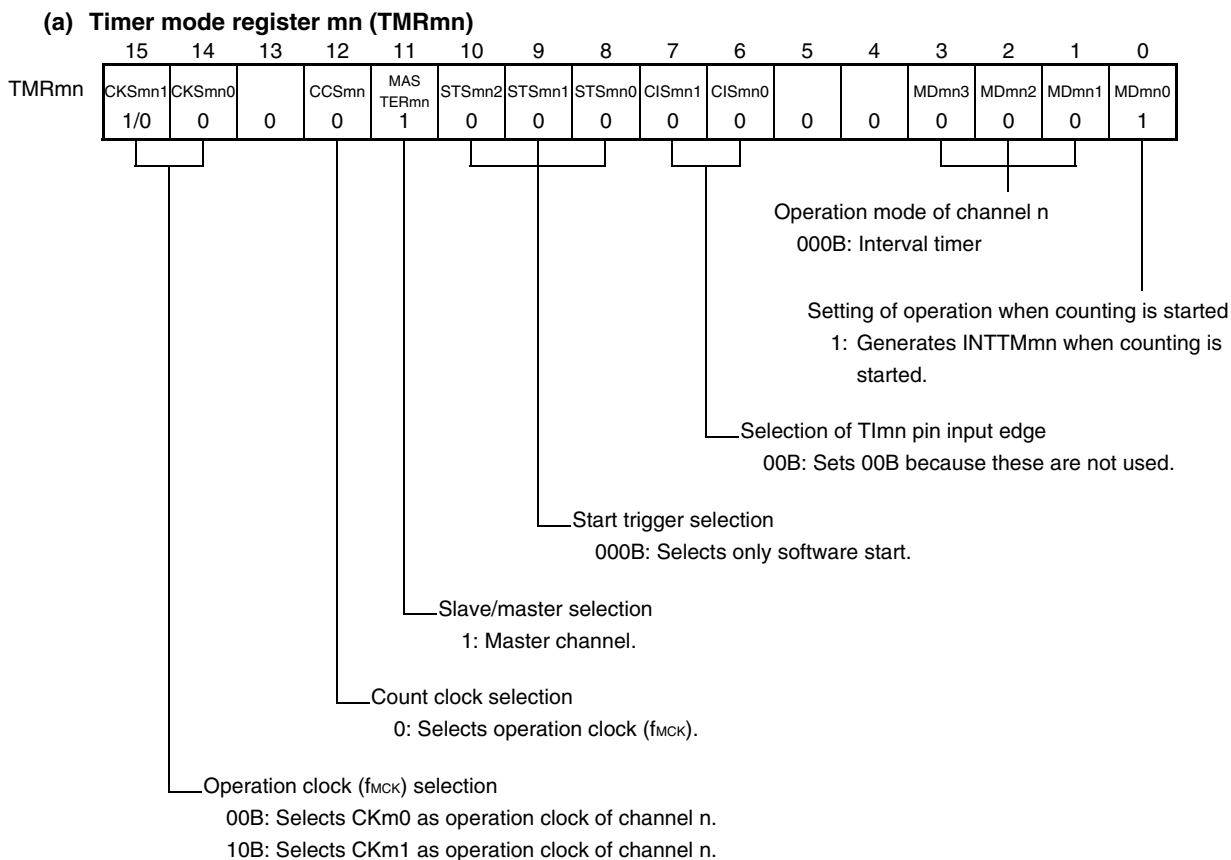


(Remark is listed on the next page.)

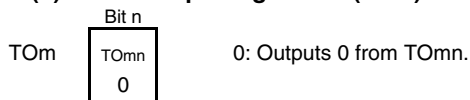
**Figure 6-72. Example of Basic Timing of Operation as Multiple PWM Output Function  
(Output two types of PWMs) (2/2)**

- Remark 1.** m: Unit number (m = 0, 1), n: Channel number (n = 0, 2, 4)  
p: Slave channel number 1, q: Slave channel number 2  
n < p < q ≤ 7 (Where p and q are consecutive integers greater than n)
- 2.** TSmn, TSmp, TSmq: Bit n, p, q of timer channel start register m (TSM)  
TEmn, TEmq, TEMq: Bit n, p, q of timer channel enable status register m (TEM)  
TCRmn, TCRmp, TCRmq: Timer count registers mn, mp, mq (TCRmn, TCRmp, TCRmq)  
TDRmn, TDRmp, TDRmq: Timer data registers mn, mp, mq (TDRmn, TDRmp, TDRmq)  
TOMn, TOMp, TOMq: TOMn, TOMp, and TOMq pins output signal

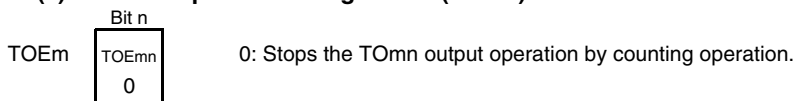
**Figure 6-73. Example of Set Contents of Registers  
When Multiple PWM Output Function (Master Channel) Is Used**



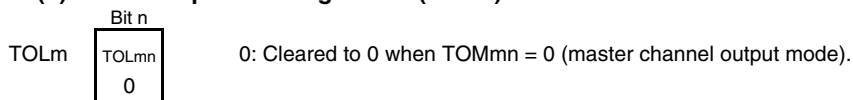
**(b) Timer output register m (TOM)**



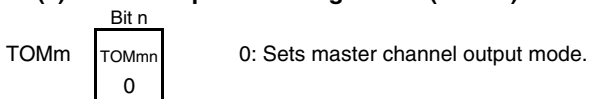
**(c) Timer output enable register m (TOEm)**



**(d) Timer output level register m (TOLm)**



**(e) Timer output mode register m (TOMm)**

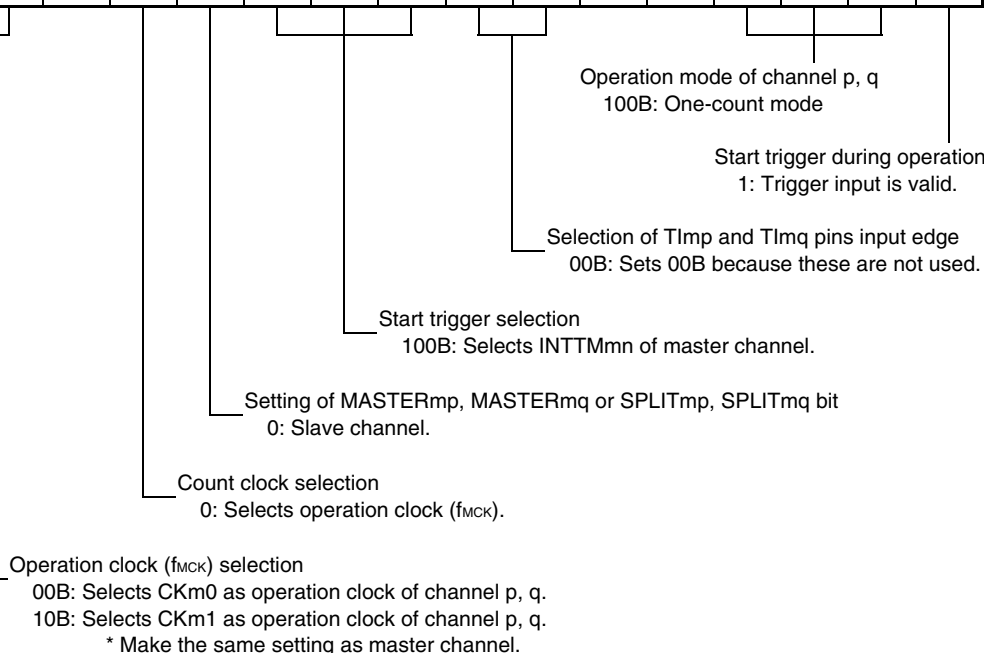


**Remark** m: Unit number (m = 0, 1), n: Channel number (n = 0, 2, 4)

**Figure 6-74. Example of Set Contents of Registers**  
**When Multiple PWM Output Function (Slave Channel) Is Used (output two types of PWMs)**

**(a) Timer mode register mp, mq (TMRmp, TMRmq)**

	15	14	13	12	11	10	9	8	7	6	5	4	3	2	1	0
TMRmp	CKSmq1	CKSmq0		CCSmq	M/S <sup>Note</sup>	STSmq2	STSmq1	STSmq0	CISmq1	CISmq0			MDmp3	MDmp2	MDmp1	MDmp0
	1/0	0	0	0	0	1	0	0	0	0	0	0	1	0	0	1
TMRmq	CKSmq1	CKSmq0		CCSmq	M/S <sup>Note</sup>	STSmq2	STSmq1	STSmq0	CISmq1	CISmq0			MDmq3	MDmq2	MDmq1	MDmq0
	1/0	0	0	0	0	1	0	0	0	0	0	0	1	0	0	1



**(b) Timer output register m (TOM)**

	Bit q	Bit p	
TOM	TOmq	TOmp	0: Outputs 0 from TOMp or TOMq. 1: Outputs 1 from TOMp or TOMq.
	1/0	1/0	

**(c) Timer output enable register m (TOEm)**

	Bit q	Bit p	
TOEm	TOEmq	TOEmp	0: Stops the TOMp or TOMq output operation by counting operation. 1: Enables the TOMp or TOMq output operation by counting operation.
	1/0	1/0	

**(d) Timer output level register m (TOLm)**

	Bit q	Bit p	
TOLm	TOLmq	TOLmp	0: Positive logic output (active-high) 1: Negative logic output (active-low)
	1/0	1/0	

**(e) Timer output mode register m (TOMm)**

	Bit q	Bit p	
TOMm	TOMmq	TOMmp	1: Sets the slave channel output mode.
	1	1	

**Note** TMRm5, TMRm7: Fixed to 0  
 TMRm1, TMRm3: SPLITmp, SPLIT0q bit  
 TMRm2, TMRm4, TMRm6: MASTERmp, MASTERmq bit

<R>

**Remark** m: Unit number (m = 0, 1), n: Channel number (n = 0, 2, 4)  
 p: Slave channel number 1, q: Slave channel number 2  
 n < p < q ≤ 7 (Where p and q are consecutive integers greater than n)

**Figure 6-75. Operation Procedure When Multiple PWM Output Function Is Used (1/2)**

	Software Operation	Hardware Status
TAU default setting		Power-off status (Clock supply is stopped and writing to each register is disabled.)
	Sets the TAUmEN bit of peripheral enable register 0 (PER0) to 1. →	Power-on status. Each channel stops operating. (Clock supply is started and writing to each register is enabled.)
	Sets timer clock select register m (TPSm). Determines clock frequencies of CKm0 and CKm1.	
Channel default setting	Sets timer mode registers mn, mp, 0q (TMRmn, TMRmp, TMRmq) of each channel to be used (determines operation mode of channels). An interval (period) value is set to timer data register mn (TDRmn) of the master channel, and a duty factor is set to the TDRmp and TDRmq registers of the slave channels.	Channel stops operating. (Clock is supplied and some power is consumed.)
	Sets slave channels. The TOMmp and TOMmq bits of timer output mode register m (TOMm) are set to 1 (slave channel output mode). Clears the TOLmp and TOLmq bits to 0. Sets the TOmp and TOMq bits and determines default level of the TOmp and TOMq outputs. →	The TOmp and TOMq pins go into Hi-Z output state.  The TOmp and TOMq default setting levels are output when the port mode register is in output mode and the port register is 0.
	Sets the TOEmp and TOEmq bits to 1 and enables operation of TOmp and TOMq. →	TOmp and TOMq do not change because channels stop operating.
	Clears the port register and port mode register to 0. →	The TOmp and TOMq pins output the TOmp and TOMq set levels.

(Note and Remark are listed on the next page.)

Figure 6-75. Operation Procedure When Multiple PWM Output Function Is Used (2/2)

	Software Operation	Hardware Status
Operation is resumed.	<p>Operation start</p> <p>(Sets the TOEmp and TOEmq (slave) bits to 1 only when resuming operation.)                      The TSmn bit (master), and TSmp and TSmq (slave) bits of timer channel start register m (TSM) are set to 1 at the same time.                      The TSmn, TSmp, and TSmq bits automatically return to 0 because they are trigger bits.</p>	<p>TEmn = 1, TEmq = 1</p> <p>When the master channel starts counting, INTTMmn is generated. Triggered by this interrupt, the slave channel also starts counting.</p>
	<p>During operation</p> <p>Set values of the TMRmn, TMRmp, TMRmq registers, TOMmn, TOMmp, TOMmq, TOLmn, TOLmp, and TOLmq bits cannot be changed.                      Set values of the TDRmn, TDRmp, and TDRmq registers can be changed after INTTMmn of the master channel is generated.                      The TCRmn, TCRmp, and TCRmq registers can always be read.                      The TSRmn, TSRmp, and TSR0q registers are not used.</p>	<p>The counter of the master channel loads the TDRmn register value to timer count register mn (TCRmn) and counts down. When the count value reaches TCRmn = 0000H, INTTMmn output is generated. At the same time, the value of the TDRmn register is loaded to the TCRmn register, and the counter starts counting down again.                      At the slave channel 1, the values of the TDRmp register are transferred to the TCRmp register, triggered by INTTMmn of the master channel, and the counter starts counting down. The output levels of TOmp become active one count clock after generation of the INTTMmn output from the master channel. It becomes inactive when TCRmp = 0000H, and the counting operation is stopped.                      At the slave channel 2, the values of the TDRmq register are transferred to TCRmq register, triggered by INTTMmn of the master channel, and the counter starts counting down. The output levels of TOMq become active one count clock after generation of the INTTMmn output from the master channel. It becomes inactive when TCRmq = 0000H, and the counting operation is stopped.                      After that, the above operation is repeated.</p>
	<p>Operation stop</p> <p>The TTmn bit (master), TTmp, and TTmq (slave) bits are set to 1 at the same time.                      The TTmn, TTmp, and TTmq bits automatically return to 0 because they are trigger bits.</p>	<p>TEmn, TEmq = 0, and count operation stops.                      The TCRmn, TCRmp, and TCRmq registers hold count value and stop.                      The TOmp and TOMq output are not initialized but hold current status.</p>
	<p>The TOEmp and TOEmq bits of slave channels are cleared to 0 and value is set to the TOmp and TOMq bits.</p>	<p>The TOmp and TOMq pins output the TOmp and TOMq set levels.</p>
<p>TAU stop</p> <p>To hold the TOmp and TOMq pin output levels                      Clears the TOmp and TOMq bits to 0 after the value to be held is set to the port register.                      When holding the TOmp and TOMq pin output levels are not necessary                      Setting not required</p>	<p>The TOmp and TOMq pin output levels are held by port function.</p>	
<p>The TAUmEN bit of the PER0 register is cleared to 0.</p>	<p>Power-off status                      All circuits are initialized and SFR of each channel is also initialized.                      (The TOmp and TOMq bits are cleared to 0 and the TOmp and TOMq pins are set to port mode.)</p>	

**Remark** m: Unit number (m = 0, 1), n: Channel number (n = 0, 2, 4)  
 p: Slave channel number 1, q: Slave channel number 2  
 n < p < q ≤ 7 (Where p and q are a consecutive integer greater than n)



## <R> 6.9 Cautions When Using Timer Array Unit

### 6.9.1 Cautions When Using Timer output

Depends on products, a pin is assigned a timer output and other alternate functions. In this case, outputs of the other alternate functions must be set in initial status.

#### (1) Using TO01 output assigned to the P16 for 20-pin products

So that the alternated SO11 output becomes 1, not only set the port mode register (the PM16 bit) and the port register (the P16 bit) to 0, but also use the serial channel enable status register 0 (SE0), serial output register 0 (SO0), and serial output enable register 0 (SOE0) with the same setting as the initial status.

#### (2) Using TO02 output assigned to the P17 for 24- and 25-pin products

So that the alternated SO11 output becomes 1, not only set the port mode register (the PM17 bit) and the port register (the P17 bit) to 0, but also use the serial channel enable status register 0 (SE0), serial output register 0 (SO0), and serial output enable register 0 (SOE0) with the same setting as the initial status.

#### (3) Using TO02 output assigned to the P17 for 20-pin products

So that the alternated SDA11 output becomes 1, not only set the port mode register (the PM17 bit) and the port register (the P17 bit) to 0, but also use the serial channel enable status register 0 (SE0), serial output register 0 (SO0), and serial output enable register 0 (SOE0) with the same setting as the initial status.

#### (4) Using TO03 output assigned to the P31 for 24- to 44-pin products

So that the alternated PCLBUZ0 output becomes 0, not only set the port mode register (the PM31 bit) and the port register (the P31 bit) to 0, but also use the bit 7 of the clock output select register 0 (CKS0) with the same setting as the initial status.

## CHAPTER 7 REAL-TIME CLOCK

### 7.1 Functions of Real-time Clock

The real-time clock has the following features.

- Having counters of year, month, week, day, hour, minute, and second, and can count up to 99 years.
- Constant-period interrupt function (period: 0.5 seconds, 1 second, 1 minute, 1 hour, 1 day, 1 month)
- Alarm interrupt function (alarm: week, hour, minute)
- Pin output function of 1 Hz (40, 44, 48, 52, 64, 80, 100, and 128-pin products only)

<R> **Caution** The count of year, month, week, day, hour, minutes and second can only be performed when a subsystem clock ( $f_{SUB} = 32.768$  kHz) is selected as the operation clock of the real-time clock. When the low-speed oscillation clock ( $f_{IL}$ ) is selected, only the constant-period interrupt function is available. The 20- to 36-pin products have the constant-period interrupt function only, because these products have no subsystem clock. However, the constant-period interrupt interval when  $f_{IL}$  is selected will be calculated with the constant-period (the value selected with RTCC0 register)  $\times f_{SUB}/f_{IL}$ .

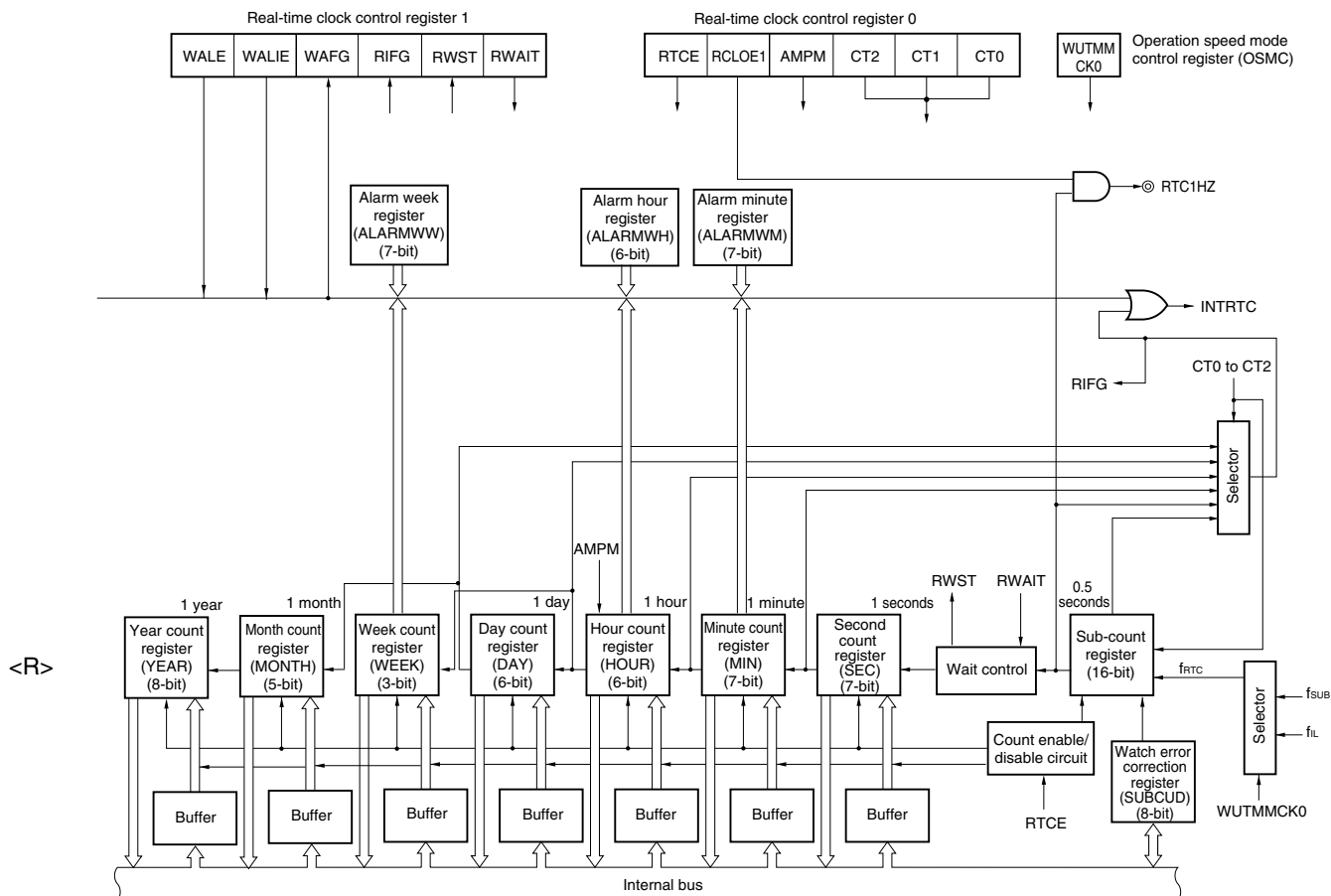
### 7.2 Configuration of Real-time Clock

The real-time clock includes the following hardware.

**Table 7-1. Configuration of Real-time Clock**

Item	Configuration
Counter	Sub-count register
Control registers	Peripheral enable register 0 (PER0)
	Operation speed mode control register (OSMC)
	Real-time clock control register 0 (RTCC0)
	Real-time clock control register 1 (RTCC1)
	Second count register (SEC)
	Minute count register (MIN)
	Hour count register (HOUR)
	Day count register (DAY)
	Week count register (WEEK)
	Month count register (MONTH)
	Year count register (YEAR)
	Watch error correction register (SUBCUD)
	Alarm minute register (ALARMWMM)
	Alarm hour register (ALARMWH)
	Alarm week register (ALARMWW)

Figure 7-1. Block Diagram of Real-time Clock



<R> **Caution** The count of year, month, week, day, hour, minutes and second can only be performed when a subsystem clock ( $f_{SUB} = 32.768 \text{ kHz}$ ) is selected as the operation clock of the real-time clock. When the low-speed oscillation clock ( $f_{IL}$ ) is selected, only the constant-period interrupt function is available. The 20- to 36-pin products have the constant-period interrupt function only, because these products have no subsystem clock. However, the constant-period interrupt interval when  $f_{IL}$  is selected will be calculated with the constant-period (the value selected with RTCC0 register)  $\times f_{SUB}/f_{IL}$ .

### 7.3 Registers Controlling Real-time Clock

The real-time clock is controlled by the following registers.

- Peripheral enable register 0 (PER0)
- Operation speed mode control register (OSMC)
- Real-time clock control register 0 (RTCC0)
- Real-time clock control register 1 (RTCC1)
- Second count register (SEC)
- Minute count register (MIN)
- Hour count register (HOUR)
- Day count register (DAY)
- Week count register (WEEK)
- Month count register (MONTH)
- Year count register (YEAR)
- Watch error correction register (SUBCUD)
- Alarm minute register (ALARMWM)
- Alarm hour register (ALARMWH)
- Alarm week register (ALARMWW)

**(1) Peripheral enable register 0 (PER0)**

This register is used to enable or disable supplying the clock to the peripheral hardware. Clock supply to a hardware macro that is not used is stopped in order to reduce the power consumption and noise.

When the real-time clock is used, be sure to set bit 7 (RTCEN) of this register to 1.

The PER0 register can be set by a 1-bit or 8-bit memory manipulation instruction.

Reset signal generation clears this register to 00H.

**Figure 7-2. Format of Peripheral Enable Register 0 (PER0)**

Address: F00F0H After reset: 00H R/W

Symbol	<7>	<6>	<5>	<4>	<3>	<2>	<1>	<0>
PER0	RTCEN	IICA1EN <small>Note 1</small>	ADCEN	IICA0EN <small>Note 2</small>	SAU1EN <small>Note 3</small>	SAU0EN	TAU1EN <small>Note 1</small>	TAU0EN

<R>

RTCEN	Control of real-time clock (RTC) and interval timer input clock supply
0	Stops input clock supply. <ul style="list-style-type: none"> <li>• SFR used by the real-time clock (RTC) and interval timer cannot be written.</li> <li>• The real-time clock (RTC) and interval timer are in the reset status.</li> </ul>
1	Enables input clock supply. <ul style="list-style-type: none"> <li>• SFR used by the real-time clock (RTC) and interval timer can be read and written.</li> </ul>

- Notes**
1. 80, 100, and 128-pin products only.
  2. This is not provided in the 20-pin products.
  3. This is not provided in the 20, 24, and 25-pin products.

- Cautions**
1. When using the real-time clock, first set the RTCEN bit to 1, while oscillation of the input clock ( $f_{RTC}$ ) is stable. If RTCEN = 0, writing to a control register of the real-time clock or interval timer is ignored, and, even if the register is read, only the default value is read.
  2. The subsystem clock supply to peripheral functions other than the real-time clock and interval timer can be stopped in STOP mode or HALT mode when the subsystem clock is used, by setting the RTCLPC bit of the operation speed mode control register (OSMC) to 1. In this case, set the RTCEN bit of the PER0 register to 1 and the other bits (bits 0 to 6) to 0.
  3. Be sure to clear the following bits to 0.
    - 20-pin products: bits 1, 3, 4, 6
    - 24, 25-pin products: bits 1, 3, 6
    - 30, 32, 36, 40, 44, 48, 52, 64-pin products: bits 1, 6

**(2) Operation speed mode control register (OSMC)**

The WUTMMCK0 bit can be used to select the real-time clock operation clock ( $f_{RTC}$ ). In addition, by stopping clock functions that are unnecessary, the RTCLPC bit can be used to reduce power consumption. For details about setting the RTCLPC bit, see **CHAPTER 5 CLOCK GENERATOR**. The OSMC register can be set by an 8-bit memory manipulation instruction. Reset signal generation clears this register to 00H.

**Figure 7-3. Format of Operation Speed Mode Control Register (OSMC)**

Address: F00F3H After reset: 00H R/W

Symbol	7	6	5	4	3	2	1	0
OSMC	RTCLPC	0	0	WUTMMCK0	0	0	0	0

WUTMMCK0	Selection of operation clock ( $f_{RTC}$ ) for real-time clock and interval timer.
0	Subsystem clock ( $f_{SUB}$ )
1	Low-speed on-chip oscillator clock ( $f_{IL}$ )

<R> **Caution** The count of year, month, week, day, hour, minutes and second can only be performed when a subsystem clock ( $f_{SUB} = 32.768 \text{ kHz}$ ) is selected as the operation clock of the real-time clock. When the low-speed oscillation clock ( $f_{IL}$ ) is selected, only the constant-period interrupt function is available. The 20- to 36-pin products have the constant-period interrupt function only, because these products have no subsystem clock. However, the constant-period interrupt interval when  $f_{IL}$  is selected will be calculated with the constant-period (the value selected with RTCC0 register)  $\times f_{SUB}/f_{IL}$ .

**(3) Real-time clock control register 0 (RTCC0)**

The RTCC0 register is an 8-bit register that is used to start or stop the real-time clock operation, control the RTC1HZ pin, and set a 12- or 24-hour system and the constant-period interrupt function.

The RTCC0 register can be set by a 1-bit or 8-bit memory manipulation instruction.

Reset signal generation clears this register to 00H.

**Figure 7-4. Format of Real-time Clock Control Register 0 (RTCC0)**

Address: FFF9DH After reset: 00H R/W

Symbol	<7>	6	<5>	4	3	2	1	0
RTCC0	RTCE	0	RCLOE1	0	AMPM	CT2	CT1	CT0

RTCE	Real-time clock operation control
0	Stops counter operation.
1	Starts counter operation.

RCLOE1	RTC1HZ pin output control
0	Disables output of the RTC1HZ pin (1 Hz).
1	Enables output of the RTC1HZ pin (1 Hz).

AMPM	Selection of 12-/24-hour system
0	12-hour system (a.m. and p.m. are displayed.)
1	24-hour system
<ul style="list-style-type: none"> <li>• Rewrite the AMPM bit value after setting the RWAIT bit (bit 0 of real-time clock control register 1 (RTCC1)) to 1. If the AMPM bit value is changed, the values of the hour count register (HOUR) change according to the specified time system.</li> <li>• Table 7-2 shows the displayed time digits that are displayed.</li> </ul>	

CT2	CT1	CT0	Constant-period interrupt (INTRTC) selection
0	0	0	Does not use constant-period interrupt function.
0	0	1	Once per 0.5 s (synchronized with second count up)
0	1	0	Once per 1 s (same time as second count up)
0	1	1	Once per 1 m (second 00 of every minute)
1	0	0	Once per 1 hour (minute 00 and second 00 of every hour)
1	0	1	Once per 1 day (hour 00, minute 00, and second 00 of every day)
1	1	×	Once per 1 month (Day 1, hour 00 a.m., minute 00, and second 00 of every month)

When changing the values of the CT2 to CT0 bits while the counter operates (RTCE = 1), rewrite the values of the CT2 to CT0 bits after disabling interrupt servicing INTRTC by using the interrupt mask flag register. Furthermore, after rewriting the values of the CT2 to CT0 bits, enable interrupt servicing after clearing the RIFG and RTCIF flags.

**Caution** Do not change the value of the RTCLOE1 bit when RTCE = 1.

**Remark** ×: don't care

**(4) Real-time clock control register 1 (RTCC1)**

The RTCC1 register is an 8-bit register that is used to control the alarm interrupt function and the wait time of the counter.

The RTCC1 register can be set by a 1-bit or 8-bit memory manipulation instruction.

Reset signal generation clears this register to 00H.

**Figure 7-5. Format of Real-time Clock Control Register 1 (RTCC1) (1/2)**

Address: FFF9EH After reset: 00H R/W

Symbol	<7>	<6>	5	<4>	<3>	2	<1>	<0>
RTCC1	WALE	WALIE	0	WAFG	RIFG	0	RWST	RWAIT

WALE	Alarm operation control
0	Match operation is invalid.
1	Match operation is valid.
When setting a value to the WALE bit while the counter operates (RTCE = 1) and WALIE = 1, rewrite the WALE bit after disabling interrupt servicing INTRTC by using the interrupt mask flag register. Furthermore, clear the WAFG and RTCIF flags after rewriting the WALE bit. When setting each alarm register (WALIE flag of real-time clock control register 1 (RTCC1), the alarm minute register (ALARMWM), the alarm hour register (ALARMWH), and the alarm week register (ALARMWW)), set match operation to be invalid ("0") for the WALE bit.	

WALIE	Control of alarm interrupt (INTRTC) function operation
0	Does not generate interrupt on matching of alarm.
1	Generates interrupt on matching of alarm.

WAFG	Alarm detection status flag
0	Alarm mismatch
1	Detection of matching of alarm
This is a status flag that indicates detection of matching with the alarm. It is valid only when WALE = 1 and is set to "1" one clock (32.768 kHz) after matching of the alarm is detected. This flag is cleared when "0" is written to it. Writing "1" to it is invalid.	



**Figure 7-5. Format of Real-time Clock Control Register 1 (RTCC1) (2/2)**

RIFG	Constant-period interrupt status flag
0	Constant-period interrupt is not generated.
1	Constant-period interrupt is generated.
<p>This flag indicates the status of generation of the constant-period interrupt. When the constant-period interrupt is generated, it is set to "1".</p> <p>This flag is cleared when "0" is written to it. Writing "1" to it is invalid.</p>	
RWST	Wait status flag of real-time clock
0	Counter is operating.
1	Mode to read or write counter value
<p>This status flag indicates whether the setting of the RWAIT bit is valid.</p> <p>Before reading or writing the counter value, confirm that the value of this flag is 1.</p>	
RWAIT	Wait control of real-time clock
0	Sets counter operation.
1	Stops SEC to YEAR counters. Mode to read or write counter value
<p>This bit controls the operation of the counter.</p> <p>Be sure to write "1" to it to read or write the counter value.</p> <p>As the sub-count register is continuing to run, complete reading or writing within one second and turn back to 0.</p> <p>When RWAIT = 1, it takes up to 1 clock (<math>f_{RTC}</math>) until the counter value can be read or written (RWST = 1).</p> <p>When the sub-count register overflowed while RWAIT = 1, it keeps the event of overflow until RWAIT = 0, then counts up.</p> <p>However, when it wrote a value to second count register, it will not keep the overflow event.</p>	

&lt;R&gt;

**Caution** If writing is performed to the RTCC1 register with a 1-bit manipulation instruction, the RIFG flag and WAFG flag may be cleared. Therefore, to perform writing to the RTCC1 register, be sure to use an 8-bit manipulation instruction. To prevent the RIFG flag and WAFG flag from being cleared during writing, disable writing by setting 1 to the corresponding bit. If the RIFG flag and WAFG flag are not used and the value may be changed, the RTCC1 register may be written by using a 1-bit manipulation instruction.

**Remark** Fixed-cycle interrupts and alarm match interrupts use the same interrupt source (INTRTC). When using these two types of interrupts at the same time, which interrupt occurred can be judged by checking the fixed-cycle interrupt status flag (RIFG) and the alarm detection status flag (WAFG) upon INTRTC occurrence.

**(5) Second count register (SEC)**

The SEC register is an 8-bit register that takes a value of 0 to 59 (decimal) and indicates the count value of seconds.

It counts up when the sub-count register overflows.

<R> When data is written to this register, it is written to a buffer and then to the counter up to 2 clocks ( $f_{RTC}$ ) later. Set a decimal value of 00 to 59 to this register in BCD code. If a value outside the range is set, the register value returns to the normal value after 1 period.

The SEC register can be set by an 8-bit memory manipulation instruction.

Reset signal generation clears this register to 00H.

**Figure 7-6. Format of Second Count Register (SEC)**

Address: FFF92H After reset: 00H R/W

Symbol	7	6	5	4	3	2	1	0
SEC	0	SEC40	SEC20	SEC10	SEC8	SEC4	SEC2	SEC1

<R> **Caution** When it reads or writes from/to the register while the counter is in operation (RTCE = 1), follow the procedures described in the section 7.4.3 Reading/writing real-time clock.

**(6) Minute count register (MIN)**

The MIN register is an 8-bit register that takes a value of 0 to 59 (decimal) and indicates the count value of minutes. It counts up when the second counter overflows.

<R> When data is written to this register, it is written to a buffer and then to the counter up to 2 clocks ( $f_{RTC}$ ) later. Even if the second count register overflows while this register is being written, this register ignores the overflow and is set to the value written. Set a decimal value of 00 to 59 to this register in BCD code. If a value outside the range is set, the register value returns to the normal value after 1 period.

The MIN register can be set by an 8-bit memory manipulation instruction.

Reset signal generation clears this register to 00H.

**Figure 7-7. Format of Minute Count Register (MIN)**

Address: FFF93H After reset: 00H R/W

Symbol	7	6	5	4	3	2	1	0
MIN	0	MIN40	MIN20	MIN10	MIN8	MIN4	MIN2	MIN1

<R> **Caution** When it reads or writes from/to the register while the counter is in operation (RTCE = 1), follow the procedures described in the section 7.4.3 Reading/writing real-time clock.

**(7) Hour count register (HOUR)**

The HOUR register is an 8-bit register that takes a value of 00 to 23 or 01 to 12 and 21 to 32 (decimal) and indicates the count value of hours.

It counts up when the minute counter overflows.

<R> When data is written to this register, it is written to a buffer and then to the counter up to 2 clocks ( $f_{RTC}$ ) later. Even if the minute count register overflows while this register is being written, this register ignores the overflow and is set to the value written. Specify a decimal value of 00 to 23, 01 to 12, or 21 to 32 by using BCD code according to the time system specified using bit 3 (AMP<sub>PM</sub>) of real-time clock control register 0 (RTCC0).

If the AMP<sub>PM</sub> bit value is changed, the values of the HOUR register change according to the specified time system.

If a value outside the range is set, the register value returns to the normal value after 1 period.

The HOUR register can be set by an 8-bit memory manipulation instruction.

Reset signal generation clears this register to 12H.

However, the value of this register is 00H if the AMP<sub>PM</sub> bit (bit 3 of the RTCC0 register) is set to 1 after reset.

**Figure 7-8. Format of Hour Count Register (HOUR)**

Address: FFF94H    After reset: 12H    R/W

Symbol	7	6	5	4	3	2	1	0
HOUR	0	0	HOUR20	HOUR10	HOUR8	HOUR4	HOUR2	HOUR1

**Cautions** 1. Bit 5 (HOUR20) of the HOUR register indicates AM(0)/PM(1) if AMP<sub>PM</sub> = 0 (if the 12-hour system is selected).

<R> 2. When it reads or writes from/to the register while the counter is in operation (RTCE = 1), follow the procedures described in the section 7.4.3 Reading/writing real-time clock.

Table 7-2 shows the relationship between the setting value of the AMPM bit, the hour count register (HOUR) value, and time.

**Table 7-2. Displayed Time Digits**

24-Hour Display (AMPM = 1)		12-Hour Display (AMPM = 1)	
Time	HOUR Register	Time	HOUR Register
0	00H	12 a.m.	12H
1	01H	1 a.m.	01H
2	02H	2 a.m.	02H
3	03H	3 a.m.	03H
4	04H	4 a.m.	04H
5	05H	5 a.m.	05H
6	06H	6 a.m.	06H
7	07H	7 a.m.	07H
8	08H	8 a.m.	08H
9	09H	9 a.m.	09H
10	10H	10 a.m.	10H
11	11H	11 a.m.	11H
12	12H	12 p.m.	32H
13	13H	1 p.m.	21H
14	14H	2 p.m.	22H
15	15H	3 p.m.	23H
16	16H	4 p.m.	24H
17	17H	5 p.m.	25H
18	18H	6 p.m.	26H
19	19H	7 p.m.	27H
20	20H	8 p.m.	28H
21	21H	9 p.m.	29H
22	22H	10 p.m.	30H
23	23H	11 p.m.	31H

The HOUR register value is set to 12-hour display when the AMPM bit is "0" and to 24-hour display when the AMPM bit is "1".

In 12-hour display, the fifth bit of the HOUR register displays 0 for AM and 1 for PM.

**(8) Day count register (DAY)**

The DAY register is an 8-bit register that takes a value of 1 to 31 (decimal) and indicates the count value of days. It counts up when the hour counter overflows.

This counter counts as follows.

- 01 to 31 (January, March, May, July, August, October, December)
- 01 to 30 (April, June, September, November)
- 01 to 29 (February, leap year)
- 01 to 28 (February, normal year)

<R> When data is written to this register, it is written to a buffer and then to the counter up to 2 clocks ( $f_{RTC}$ ) later. Even if the hour count register overflows while this register is being written, this register ignores the overflow and is set to the value written. Set a decimal value of 01 to 31 to this register in BCD code. If a value outside the range is set, the register value returns to the normal value after 1 period.

The DAY register can be set by an 8-bit memory manipulation instruction.

Reset signal generation clears this register to 01H.

**Figure 7-9. Format of Day Count Register (DAY)**

Address: FFF96H    After reset: 01H    R/W

Symbol	7	6	5	4	3	2	1	0
DAY	0	0	DAY20	DAY10	DAY8	DAY4	DAY2	DAY1

<R> **Caution** When it reads or writes from/to the register while the counter is in operation ( $RTCE = 1$ ), follow the procedures described in the section 7.4.3 Reading/writing real-time clock.

**(9) Week count register (WEEK)**

The WEEK register is an 8-bit register that takes a value of 0 to 6 (decimal) and indicates the count value of weekdays.

It counts up in synchronization with the day counter.

<R> When data is written to this register, it is written to a buffer and then to the counter up to 2 clocks ( $f_{RTC}$ ) later. Set a decimal value of 00 to 06 to this register in BCD code. If a value outside the range is set, the register value returns to the normal value after 1 period.

The WEEK register can be set by an 8-bit memory manipulation instruction.

Reset signal generation clears this register to 00H.

**Figure 7-10. Format of Week Count Register (WEEK)**

Address: FFF95H After reset: 00H R/W

Symbol	7	6	5	4	3	2	1	0
WEEK	0	0	0	0	0	WEEK4	WEEK2	WEEK1

**Cautions 1. The value corresponding to the month count register (MONTH) or the day count register (DAY) is not stored in the week count register (WEEK) automatically. After reset release, set the week count register as follow.**

Day	WEEK
Sunday	00H
Monday	01H
Tuesday	02H
Wednesday	03H
Thursday	04H
Friday	05H
Saturday	06H

<R> **2. When it reads or writes from/to the register while the counter is in operation (RTCE = 1), follow the procedures described in the section 7.4.3 Reading/writing real-time clock.**

**(10) Month count register (MONTH)**

The MONTH register is an 8-bit register that takes a value of 1 to 12 (decimal) and indicates the count value of months.

It counts up when the day counter overflows.

<R> When data is written to this register, it is written to a buffer and then to the counter up to 2 clocks (f<sub>RTC</sub>) later. Even if the day count register overflows while this register is being written, this register ignores the overflow and is set to the value written. Set a decimal value of 01 to 12 to this register in BCD code. If a value outside the range is set, the register value returns to the normal value after 1 period.

The MONTH register can be set by an 8-bit memory manipulation instruction.

Reset signal generation clears this register to 01H.

**Figure 7-11. Format of Month Count Register (MONTH)**

Address: FFF97H    After reset: 01H    R/W

Symbol	7	6	5	4	3	2	1	0
MONTH	0	0	0	MONTH10	MONTH8	MONTH4	MONTH2	MONTH1

<R> **Caution** When it reads or writes from/to the register while the counter is in operation (RTCE = 1), follow the procedures described in the section 7.4.3 Reading/writing real-time clock.

**(11) Year count register (YEAR)**

The YEAR register is an 8-bit register that takes a value of 0 to 99 (decimal) and indicates the count value of years. It counts up when the month count register (MONTH) overflows.

Values 00, 04, 08, ..., 92, and 96 indicate a leap year.

<R> When data is written to this register, it is written to a buffer and then to the counter up to 2 clocks (f<sub>RTC</sub>) later. Even if the MONTH register overflows while this register is being written, this register ignores the overflow and is set to the value written. Set a decimal value of 00 to 99 to this register in BCD code. If a value outside the range is set, the register value returns to the normal value after 1 period.

The YEAR register can be set by an 8-bit memory manipulation instruction.

Reset signal generation clears this register to 00H.

**Figure 7-12. Format of Year Count Register (YEAR)**

Address: FFF98H    After reset: 00H    R/W

Symbol	7	6	5	4	3	2	1	0
YEAR	YEAR80	YEAR40	YEAR20	YEAR10	YEAR8	YEAR4	YEAR2	YEAR1

<R> **Caution** When it reads or writes from/to the register while the counter is in operation (RTCE = 1), follow the procedures described in the section 7.4.3 Reading/writing real-time clock.

**(12) Watch error correction register (SUBCUD)**

This register is used to correct the watch with high accuracy when it is slow or fast by changing the value that overflows from the sub-count register to the second count register (SEC) (reference value: 7FFFH).

The SUBCUD register can be set by an 8-bit memory manipulation instruction.

Reset signal generation clears this register to 00H.

**Figure 7-13. Format of Watch Error Correction Register (SUBCUD)**

Address: FFF99H After reset: 00H R/W

Symbol	7	6	5	4	3	2	1	0
SUBCUD	DEV	F6	F5	F4	F3	F2	F1	F0

DEV	Setting of watch error correction timing
0	Corrects watch error when the second digits are at 00, 20, or 40 (every 20 seconds).
1	Corrects watch error only when the second digits are at 00 (every 60 seconds).
Writing to the SUBCUD register at the following timing is prohibited.	
<ul style="list-style-type: none"> <li>• When DEV = 0 is set: For a period of SEC = 00H, 20H, 40H</li> <li>• When DEV = 1 is set: For a period of SEC = 00H</li> </ul>	

F6	Setting of watch error correction value
0	Increases by $\{(F5, F4, F3, F2, F1, F0) - 1\} \times 2$ .
1	Decreases by $\{(\overline{F5}, \overline{F4}, \overline{F3}, \overline{F2}, \overline{F1}, \overline{F0}) + 1\} \times 2$ .
When (F6, F5, F4, F3, F2, F1, F0) = (*, 0, 0, 0, 0, 0, *), the watch error is not corrected. * is 0 or 1.	
/F5 to /F0 are the inverted values of the corresponding bits (000011 when 111100).	
Range of correction value: (when F6 = 0) 2, 4, 6, 8, ..., 120, 122, 124	
(when F6 = 1) -2, -4, -6, -8, ..., -120, -122, -124	

The range of value that can be corrected by using the watch error correction register (SUBCUD) is shown below.

	DEV = 0 (correction every 20 seconds)	DEV = 1 (correction every 60 seconds)
Correctable range	-189.2 ppm to 189.2 ppm	-63.1 ppm to 63.1 ppm
Maximum excludes quantization error	± 1.53 ppm	± 0.51 ppm
Minimum resolution	± 3.05 ppm	± 1.02 ppm

**Remark** If a correctable range is - 63.1 ppm or lower and 63.1 ppm or higher, set 0 to DEV.



**(13) Alarm minute register (ALARMWWM)**

This register is used to set minutes of alarm.

The ALARMWWM register can be set by an 8-bit memory manipulation instruction.

Reset signal generation clears this register to 00H.

**Caution** Set a decimal value of 00 to 59 to this register in BCD code. If a value outside the range is set, the alarm is not detected.

**Figure 7-14. Format of Alarm Minute Register (ALARMWWM)**

Address: FFF9AH After reset: 00H R/W

Symbol	7	6	5	4	3	2	1	0
ALARMWWM	0	WM40	WM20	WM10	WM8	WM4	WM2	WM1

**(14) Alarm hour register (ALARMWH)**

This register is used to set hours of alarm.

The ALARMWH register can be set by an 8-bit memory manipulation instruction.

Reset signal generation clears this register to 12H.

However, the value of this register is 00H if the AMPM bit (bit 3 of the RTCC0 register) is set to 1 after reset.

**Caution** Set a decimal value of 00 to 23, 01 to 12, or 21 to 32 to this register in BCD code. If a value outside the range is set, the alarm is not detected.

**Figure 7-15. Format of Alarm Hour Register (ALARMWH)**

Address: FFF9BH After reset: 12H R/W

Symbol	7	6	5	4	3	2	1	0
ALARMWH	0	0	WH20	WH10	WH8	WH4	WH2	WH1

**Caution** Bit 5 (WH20) of the ALARMWH register indicates AM(0)/PM(1) if AMPM = 0 (if the 12-hour system is selected).

**(15) Alarm week register (ALARMWW)**

This register is used to set date of alarm.

The ALARMWW register can be set by an 8-bit memory manipulation instruction.

Reset signal generation clears this register to 00H.

**Figure 7-16. Format of Alarm Week Register (ALARMWW)**

Address: FFF9CH After reset: 00H R/W

Symbol	7	6	5	4	3	2	1	0
ALARMWW	0	WW6	WW5	WW4	WW3	WW2	WW1	WW0

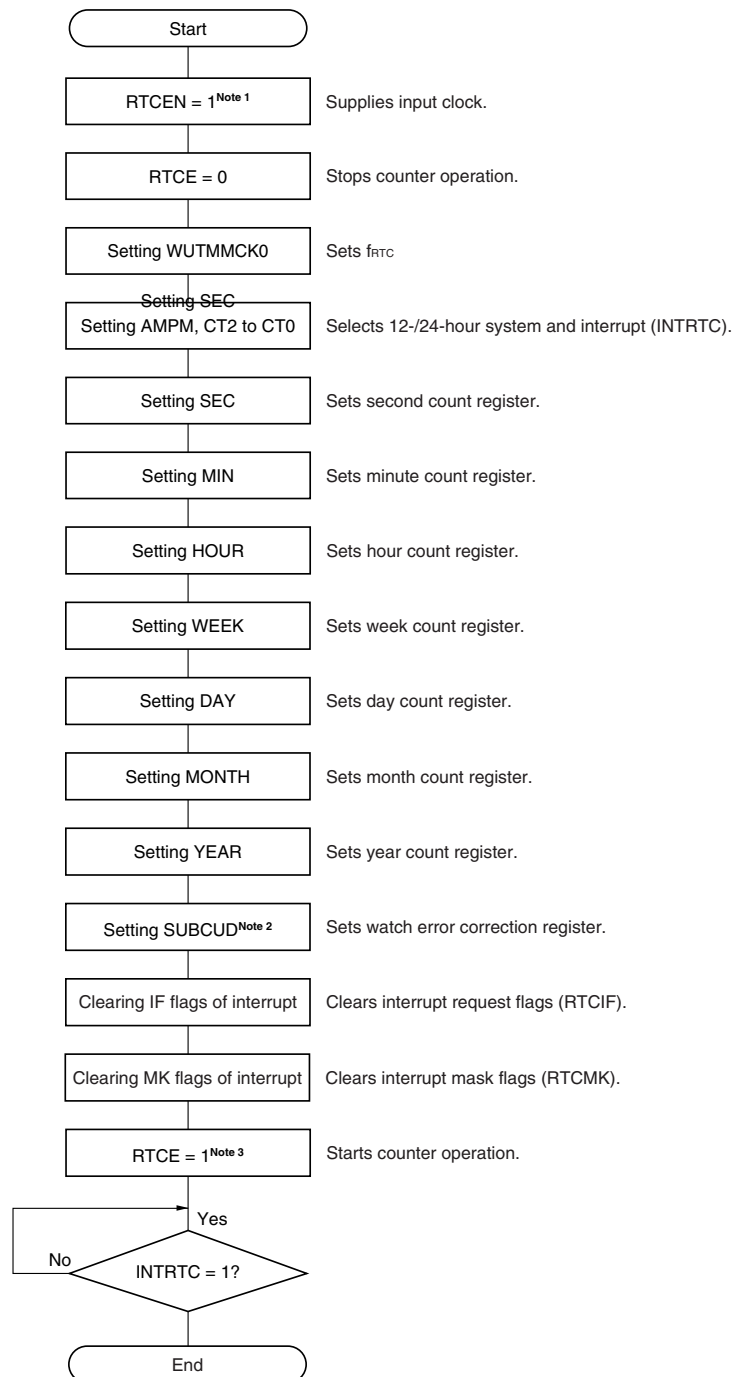
Here is an example of setting the alarm.

Time of Alarm	Day							12-Hour Display				24-Hour Display			
	Sunday	Monday	Tuesday	Wednesday	Thursday	Friday	Saturday	Hour 10	Hour 1	Minute 10	Minute 1	Hour 10	Hour 1	Minute 10	Minute 1
	W 0	W 1	W 2	W 3	W 4	W 5	W 6								
Every day, 0:00 a.m.	1	1	1	1	1	1	1	1	2	0	0	0	0	0	0
Every day, 1:30 a.m.	1	1	1	1	1	1	1	0	1	3	0	0	1	3	0
Every day, 11:59 a.m.	1	1	1	1	1	1	1	1	1	5	9	1	1	5	9
Monday through Friday, 0:00 p.m.	0	1	1	1	1	1	0	3	2	0	0	1	2	0	0
Sunday, 1:30 p.m.	1	0	0	0	0	0	0	2	1	3	0	1	3	3	0
Monday, Wednesday, Friday, 11:59 p.m.	0	1	0	1	0	1	0	3	1	5	9	2	3	5	9

## 7.4 Real-time Clock Operation

### 7.4.1 Starting operation of real-time clock

Figure 7-17. Procedure for Starting Operation of Real-time Clock



- Notes**
1. First set the RTCEN bit to 1, while oscillation of the input clock ( $f_{RTC}$ ) is stable.
  2. Set up the SUBCUD register only if the watch error must be corrected. For details about how to calculate the correction value, see **7.4.6 Example of watch error correction of real-time clock**.
  3. Confirm the procedure described in **7.4.2 Shifting to STOP mode after starting operation** when shifting to STOP mode without waiting for INTRTC = 1 after RTCE = 1.

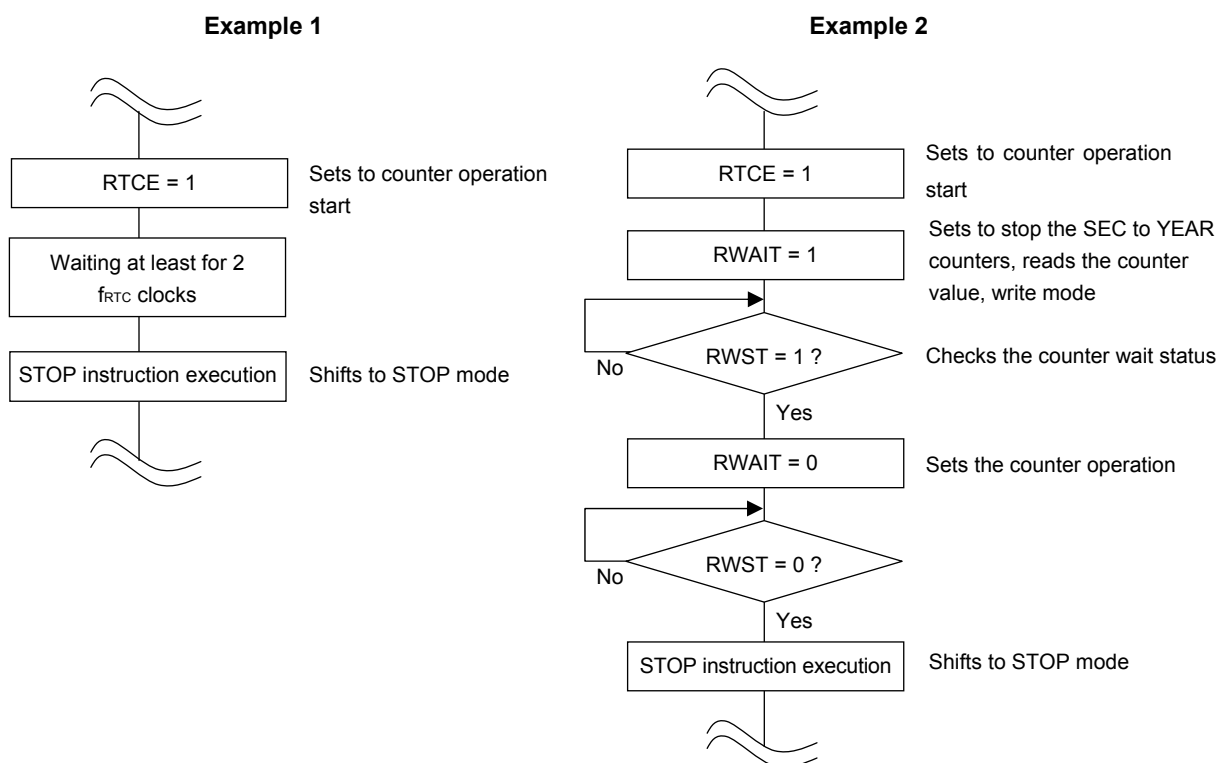
**7.4.2 Shifting to STOP mode after starting operation**

Perform one of the following processing when shifting to STOP mode immediately after setting the RTCE bit to 1.

However, after setting the RTCE bit to 1, this processing is not required when shifting to STOP mode after the INTRTC interrupt has occurred.

- Shifting to STOP mode when at least two input clocks ( $f_{RTC}$ ) have elapsed after setting the RTCE bit to 1 (see **Figure 7-18, Example 1**).
- Checking by polling the RWST bit to become 1, after setting the RTCE bit to 1 and then setting the RWAIT bit to 1. Afterward, setting the RWAIT bit to 0 and shifting to STOP mode after checking again by polling that the RWST bit has become 0 (see **Figure 7-18, Example 2**).

**Figure 7-18. Procedure for Shifting to STOP Mode After Setting RTCE bit to 1**

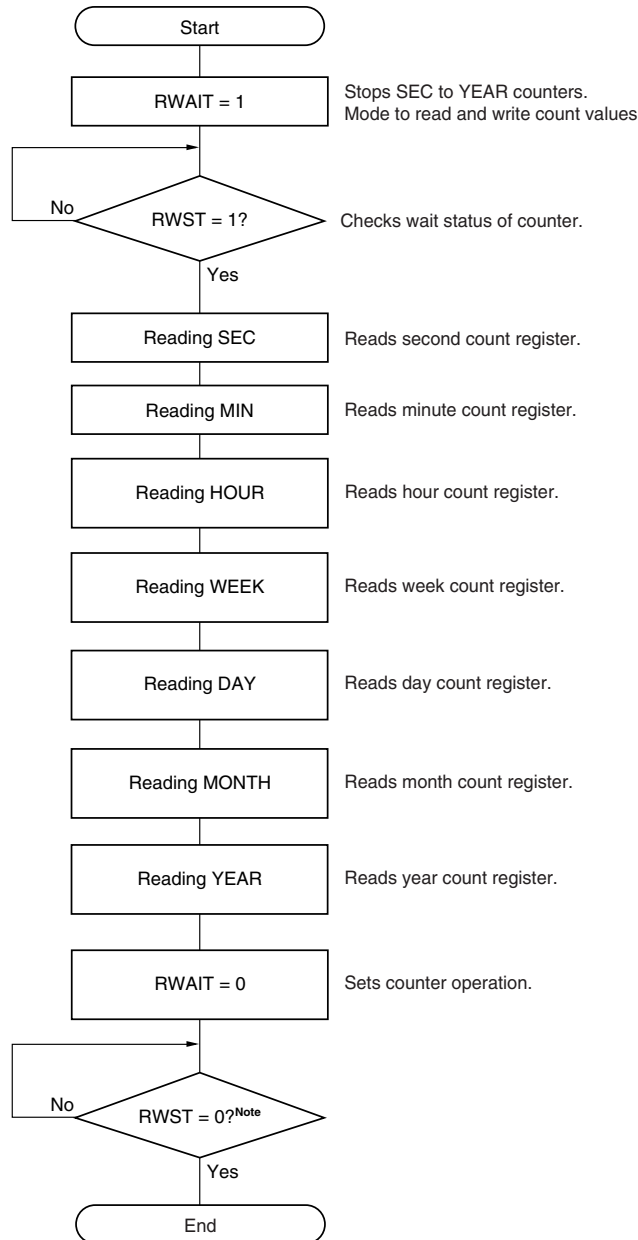


**7.4.3 Reading/writing real-time clock**

Read or write the counter after setting 1 to RWAIT first.

<R> Set RWAIT to 0 after completion of reading or writing the counter.

**Figure 7-19. Procedure for Reading Real-time Clock**



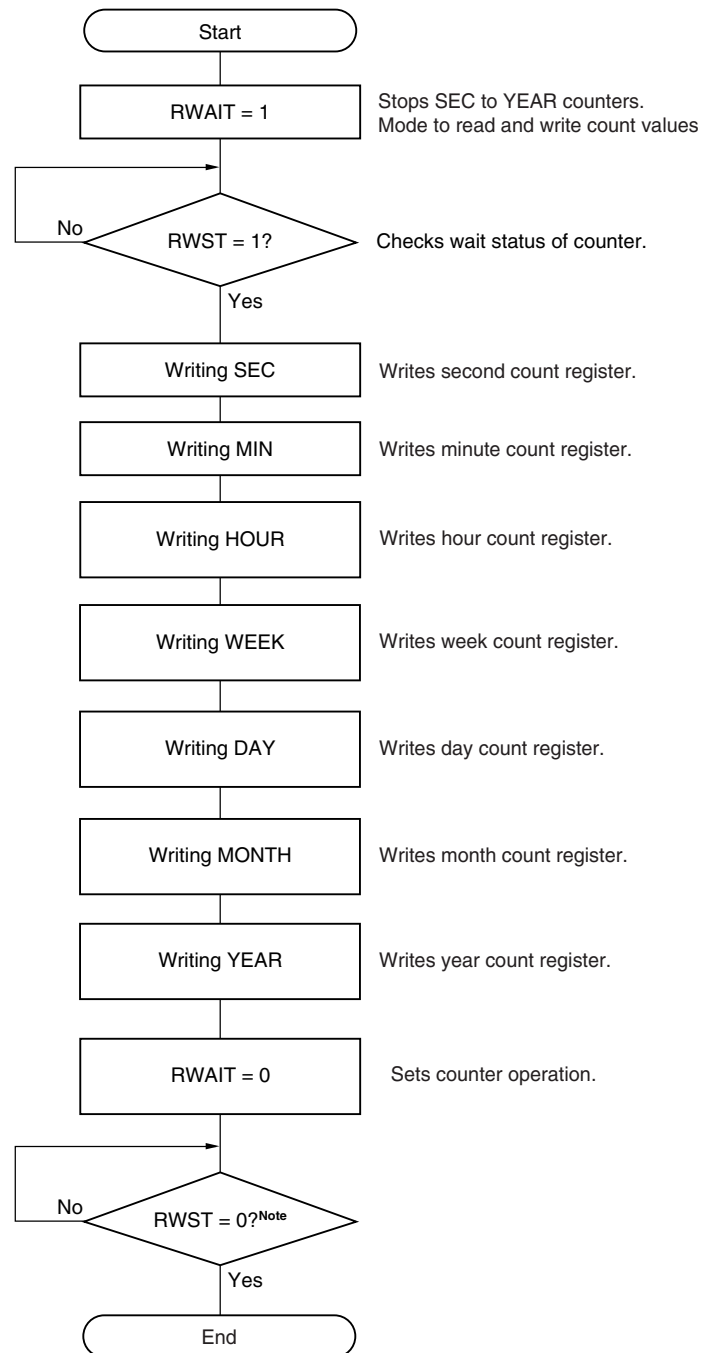
**Note** Be sure to confirm that RWST = 0 before setting STOP mode.

**Caution** Complete the series of process of setting the RWAIT bit to 1 to clearing the RWAIT bit to 0 within 1 second.

**Remark** The second count register (SEC), minute count register (MIN), hour count register (HOUR), week count register (WEEK), day count register (DAY), month count register (MONTH), and year count register (YEAR) may be read in any sequence.

All the registers do not have to read and only some registers may be read.

Figure 7-20. Procedure for Writing Real-time Clock



**Note** Be sure to confirm that RWST = 0 before setting STOP mode.

- <R> **Cautions**
1. Complete the series of operations of setting the RWAIT bit to 1 to clearing the RWAIT bit to 0 within 1 second.
  2. When changing the values of the SEC, MIN, HOUR, WEEK, DAY, MONTH, and YEAR register while the counter operates (RTCE = 1), rewrite the values of the MIN register after disabling interrupt servicing INTRTC by using the interrupt mask flag register. Furthermore, clear the WAFG, RIFG and RTCIF flags after rewriting the MIN register.

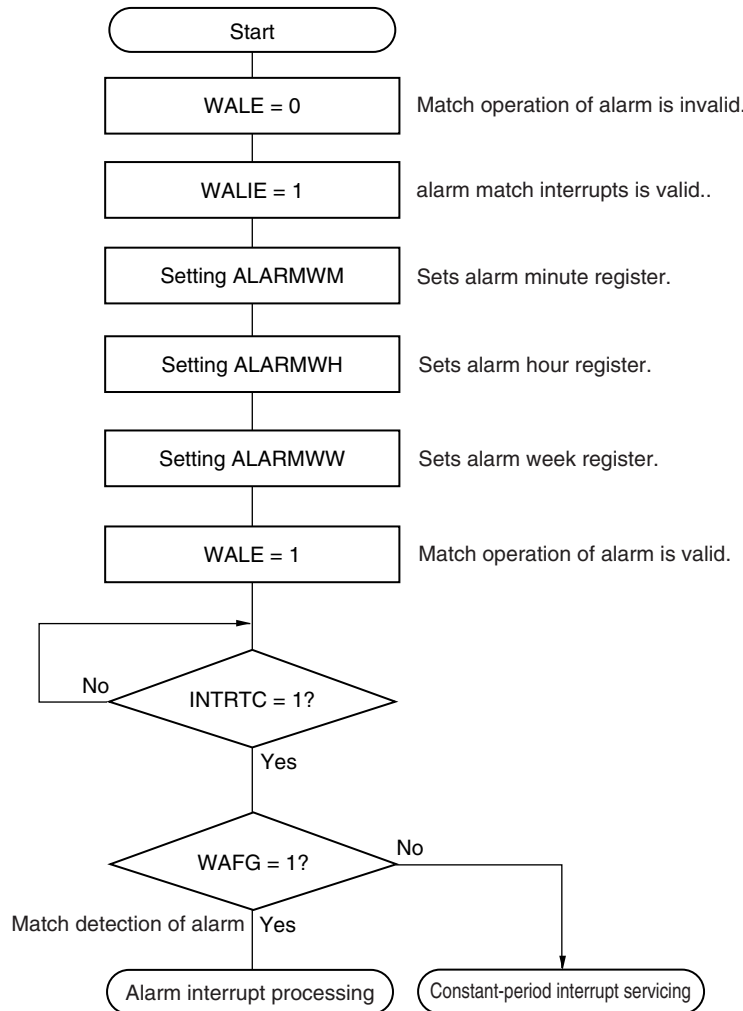
**Remark** The second count register (SEC), minute count register (MIN), hour count register (HOUR), week count register (WEEK), day count register (DAY), month count register (MONTH), and year count register (YEAR) may be written in any sequence.

All the registers do not have to be set and only some registers may be written.

7.4.4 Setting alarm of real-time clock

Set time of alarm after setting 0 to WALE (alarm operation invalid.) first.

Figure 7-21. Alarm processing Procedure

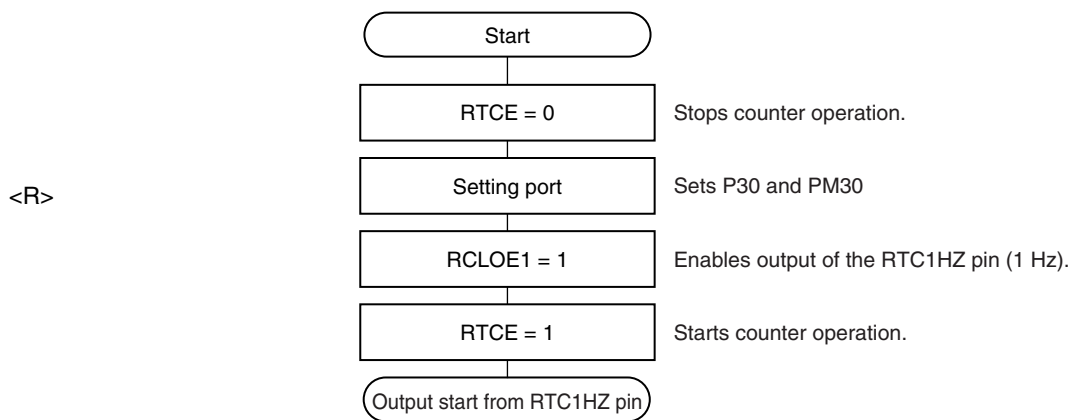


**Remarks 1.** The alarm week register (ALARMWW), alarm hour register (ALARMWH), and alarm week register (ALARMWW) may be written in any sequence.

**2.** Fixed-cycle interrupts and alarm match interrupts use the same interrupt source (INTRTC). When using these two types of interrupts at the same time, which interrupt occurred can be judged by checking the fixed-cycle interrupt status flag (RIFG) and the alarm detection status flag (WAFG) upon INTRTC occurrence.

## 7.4.5 1 Hz output of real-time clock

Figure 7-22. 1 Hz Output Setting Procedure



**Caution** First set the RTCEN bit to 1, while oscillation of the input clock ( $f_{SUB}$ ) is stable.



### 7.4.6 Example of watch error correction of real-time clock

The watch can be corrected with high accuracy when it is slow or fast, by setting a value to the watch error correction register.

#### Example of calculating the correction value

The correction value used when correcting the count value of the sub-count register is calculated by using the following expression.

Set the DEV bit to 0 when the correction range is  $-63.1$  ppm or less, or  $63.1$  ppm or more.

(When DEV = 0)

$$\text{Correction value}^{\text{Note}} = \text{Number of correction counts in 1 minute} \div 3 = (\text{Oscillation frequency} \div \text{Target frequency} - 1) \times 32768 \times 60 \div 3$$

(When DEV = 1)

$$\text{Correction value}^{\text{Note}} = \text{Number of correction counts in 1 minute} = (\text{Oscillation frequency} \div \text{Target frequency} - 1) \times 32768 \times 60$$

**Note** The correction value is the watch error correction value calculated by using bits 6 to 0 of the watch error correction register (SUBCUD).

$$(\text{When } F6 = 0) \text{ Correction value} = \{(F5, F4, F3, F2, F1, F0) - 1\} \times 2$$

$$(\text{When } F6 = 1) \text{ Correction value} = -\{(/F5, /F4, /F3, /F2, /F1, /F0) + 1\} \times 2$$

When (F6, F5, F4, F3, F2, F1, F0) is (\*, 0, 0, 0, 0, 0, \*), watch error correction is not performed. "\*" is 0 or 1. /F5 to /F0 are bit-inverted values (000011 when 111100).

- Remarks**
1. The correction value is 2, 4, 6, 8, ... 120, 122, 124 or  $-2, -4, -6, -8, \dots -120, -122, -124$ .
  2. The oscillation frequency is the input clock ( $f_{\text{RTC}}$ ).  
It can be calculated from the output frequency of the RTC1HZ pin  $\times 32768$  when the watch error correction register is set to its initial value (00H).
  3. The target frequency is the frequency resulting after correction performed by using the watch error correction register.

**Correction example**

Example of correcting from 32767.4 Hz to 32768 Hz (32767.4 Hz + 18.3 ppm)

[Measuring the oscillation frequency]

The oscillation frequency<sup>Note</sup> of each product is measured by outputting about 1 Hz from the RTC1HZ pin when the watch error correction register (SUBCUD) is set to its initial value (00H).

**Note** See 7.4.5 1 Hz output of real-time clock for the setting procedure of outputting about 1 Hz from the RTC1HZ pin.

[Calculating the correction value]

(When the output frequency from the RTCCL pin is 0.9999817 Hz)

Oscillation frequency =  $32768 \times 0.9999817 \approx 32767.4$  Hz

Assume the target frequency to be 32768 Hz (32767.4 Hz + 18.3 ppm) and DEV to be 1.

The expression for calculating the correction value when DEV is 1 is applied.

$$\begin{aligned} \text{Correction value} &= \text{Number of correction counts in 1 minute} \\ &= (\text{Oscillation frequency} \div \text{Target frequency} - 1) \times 32768 \times 60 \\ &= (32767.4 \div 32768 - 1) \times 32768 \times 60 \\ &= -36 \end{aligned}$$

[Calculating the values to be set to (F6 to F0)]

(When the correction value is -36)

If the correction value is 0 or less (when quickening), assume F6 to be 1.

Calculate (F5, F4, F3, F2, F1, F0) from the correction value.

$$\begin{aligned} - \{ (/F5, /F4, /F3, /F2, /F1, /F0) - 1 \} \times 2 &= -36 \\ (/F5, /F4, /F3, /F2, /F1, /F0) &= 17 \\ (/F5, /F4, /F3, /F2, /F1, /F0) &= (0, 1, 0, 0, 0, 1) \\ (F5, F4, F3, F2, F1, F0) &= (1, 0, 1, 1, 1, 0) \end{aligned}$$

Consequently, when correcting from 32767.4 Hz to 32768 Hz (32767.4 Hz + 18.3 ppm), setting the correction register such that DEV is 1 and the correction value is -36 (bits 6 to 0 of the SUBCUD register: 1101110) results in 32768 Hz (0 ppm).

Figure 7-23 shows the operation when (DEV, F6, F5, F4, F3, F2, F1, F0) is (1, 1, 1, 0, 1, 1, 1, 0).



CHAPTER 8 INTERVAL TIMER

8.1 Functions of Interval Timer

<R> An interrupt (INTIT) is generated at any previously specified time interval. It can be utilized for wakeup from STOP mode and triggering an A/D converter’s SNOOZE mode.

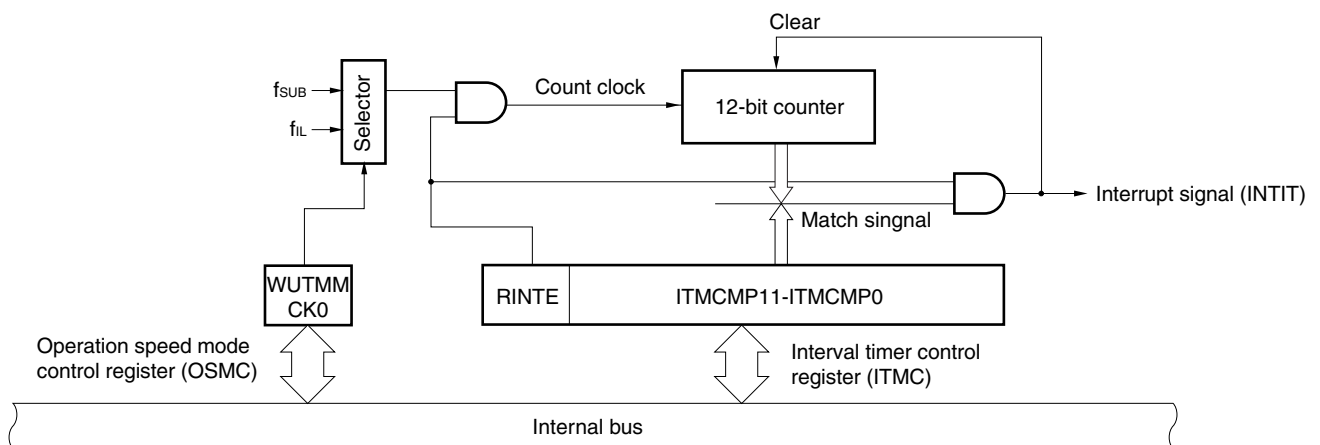
8.2 Configuration of Interval Timer

The interval timer includes the following hardware.

Table 8-1. Configuration of Interval Timer

Item	Configuration
Counter	12-bit counter
Control registers	Peripheral enable register 0 (PER0)
	Operation speed mode control register (OSMC)
	Interval timer control register (ITMC)

Figure 8-1. Block Diagram of Interval Timer



### 8.3 Registers Controlling Interval Timer

The interval timer is controlled by the following registers.

- Peripheral enable register 0 (PER0)
- Operation speed mode control register (OSMC)
- Interval timer control register (ITMC)

#### (1) Peripheral enable register 0 (PER0)

This register is used to enable or disable supplying the clock to the peripheral hardware. Clock supply to a hardware macro that is not used is stopped in order to reduce the power consumption and noise.

When the interval timer is used, be sure to set bit 7 (RTCEN) of this register to 1.

The PER0 register can be set by a 1-bit or 8-bit memory manipulation instruction.

Reset signal generation clears this register to 00H.

**Figure 8-2. Format of Peripheral Enable Register 0 (PER0)**

Address: F00F0H After reset: 00H R/W

Symbol	<7>	<6>	<5>	<4>	<3>	<2>	<1>	<0>
PER0	RTCEN	IICA1EN <small>Note 1</small>	ADCEN	IICA0EN <small>Note 2</small>	SAU1EN <small>Note 3</small>	SAU0EN	TAU1EN <small>Note 1</small>	TAU0EN

RTCEN	Control of real-time clock (RTC) and interval timer input clock supply
0	Stops input clock supply. <ul style="list-style-type: none"> <li>• SFR used by the real-time clock (RTC) and interval timer cannot be written.</li> <li>• The real-time clock (RTC) and interval timer are in the reset status.</li> </ul>
1	Enables input clock supply. <ul style="list-style-type: none"> <li>• SFR used by the real-time clock (RTC) and interval timer can be read and written.</li> </ul>

- Notes**
1. 80, 100, and 128-pin products only.
  2. This is not provided in the 20-pin products.
  3. This is not provided in the 20, 24, and 25-pin products.

- Cautions**
1. When using the interval timer, first set the RTCEN bit to 1, while oscillation of the input clock ( $f_{RTC}$ ) is stable. If RTCEN = 0, writing to a control register of the real-time clock or interval timer is ignored, and, even if the register is read, only the default value is read.
  2. Clock supply to peripheral functions other than the real-time clock and interval timer can be stopped in STOP mode or HALT mode when the subsystem clock is used, by setting the RTCLPC bit of the operation speed mode control register (OSMC) to 1. In this case, set the RTCEN bit of the PER0 register to 1 and the other bits (bits 0 to 6) to 0.
  3. Be sure to clear the following bits to 0.
    - 20-pin products: bits 1, 3, 4, 6
    - 24, 25-pin products: bits 1, 3, 6
    - 30, 32, 36, 40, 44, 48, 52, 64-pin products: bits 1, 6

**(2) Operation speed mode control register (OSMC)**

The WUTMMCK0 bit can be used to select the interval timer operation clock.

In addition, by stopping clock functions that are unnecessary, the RTCLPC bit can be used to reduce power consumption. For details about setting the RTCLPC bit, see **CHAPTER 5 CLOCK GENERATOR**.

The OSMC register can be set by an 8-bit memory manipulation instruction.

Reset signal generation clears this register to 00H.

**Figure 8-3. Format of Operation Speed Mode Control Register (OSMC)**

Address: F00F3H After reset: 00H R/W

Symbol	7	6	5	4	3	2	1	0
OSMC	RTCLPC	0	0	WUTMMCK0	0	0	0	0

WUTMMCK0	Selection of operation clock for real-time clock and interval timer.
0	Subsystem clock ( $f_{SUB}$ )
1	Low-speed on-chip oscillator clock ( $f_{L}$ )

**(3) Interval timer control register (ITMC)**

This register is used to set up the starting and stopping of the interval timer operation and to specify the timer compare value.

The ITMC register can be set by a 16-bit memory manipulation instruction.

Reset signal generation clears this register to 0FFFH.

**Figure 8-4. Format of Interval Timer Control Register (ITMC)**

Address: FFF90H After reset: 0FFFH R/W

Symbol	15	14	13	12	11 to 0
ITMC	RINTE	0	0	0	ITCMP11 to ITCMP0

RINTE	Interval timer operation control
0	Count operation stopped (count clear)
1	Count operation started

ITCMP11 to ITCMP0	Specification of the interval timer compare value
001H	These bits generate an interrupt at the fixed cycle (count clock cycles x (ITCMP setting + 1)).
•	
•	
FFFH	
000H	Setting prohibit

Example interrupt cycles when 001H or FFFH is specified for ITCMP11 to ITCMP0

- ITCMP11 to ITCMP0 = 001H, count clock: when  $f_{SUB} = 32.768 \text{ kHz}$   
 $1/32.768 \text{ [kHz]} \times (1 + 1) = 0.06103515625 \text{ [ms]} \cong 61.03 \text{ [}\mu\text{s]}$
- ITCMP11 to ITCMP0 = FFFH, count clock: when  $f_{SUB} = 32.768 \text{ kHz}$   
 $1/32.768 \text{ [kHz]} \times (4095 + 1) = 125 \text{ [ms]}$

<R>

- Cautions**
1. Before changing the RINTE bit from 1 to 0, use the interrupt mask flag register to disable the INTIT interrupt servicing. When the operation starts (from 0 to 1) again, clear the ITIF flag, and then enable the interrupt servicing.
  2. The value read from the RINTE bit is applied one count clock cycle after setting the RINTE bit.
  3. Only change the setting of the ITCMP11 to ITCMP0 bits when RINTE = 0.  
 However, it is possible to change the settings of the ITCMP11 to ITCMP0 bits at the same time as when changing RINTE from 0 to 1 or 1 to 0.

### 8.4 Interval Timer Operation

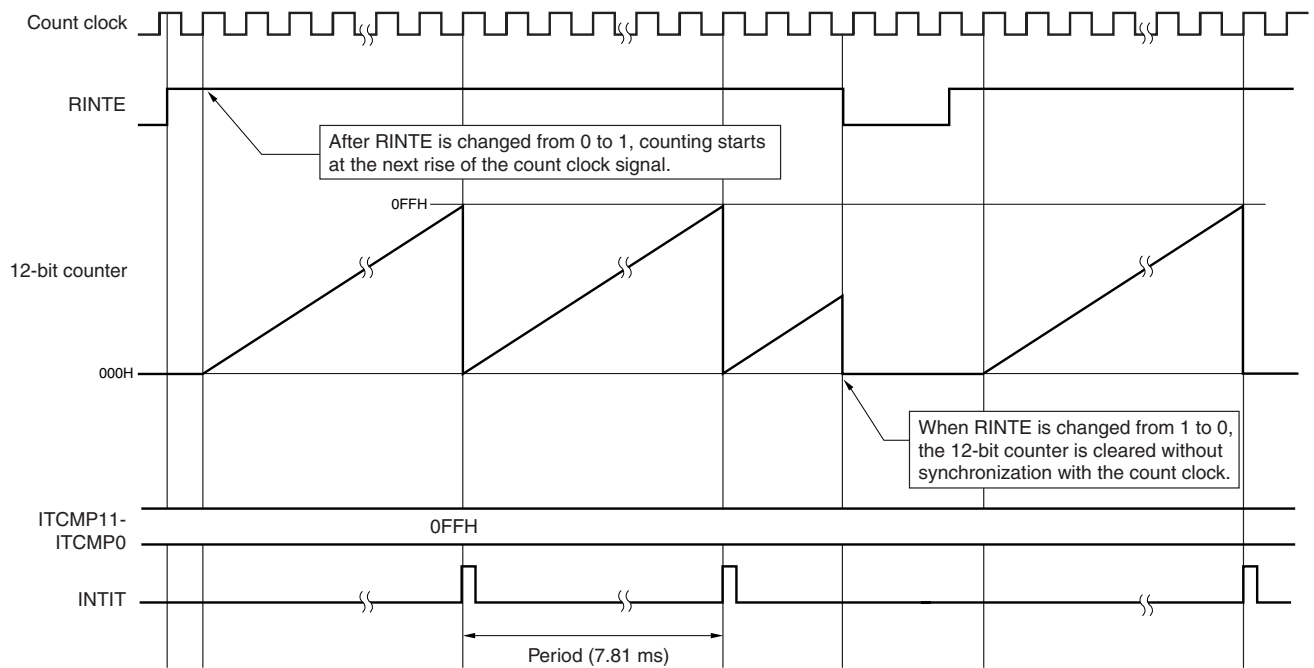
The count value specified for the ITCMP11 to ITCMP0 bits is used as an interval to operate an interval timer that repeatedly generates interrupt requests (INTIT).

When the RINTE bit is set to 1, the 12-bit counter starts counting.

When the 12-bit counter value matches the value specified for the ITCMP11 to ITCMP0 bits, the 12-bit counter value is cleared to 0, counting continues, and an interrupt request signal (INTIT) is generated at the same time.

The basic operation of the interval timer is as follows.

**Figure 8-5. Interval Timer Operation Timing (ITCMP11 to ITCMP0 = 0FFH, count clock:  $f_{SUB} = 32.768$  kHz)**





## CHAPTER 9 CLOCK OUTPUT/BUZZER OUTPUT CONTROLLER

The number of output pins of the clock output and buzzer output controllers differs, depending on the product.

Output pin	20-pin	24, 25-pin	30, 32, 36, 40, 44, 48, 52, 64, 80, 100, 128-pin
PCLBUZ0	–	√	√
PCLBUZ1	–	–	√

**Caution** Most of the following descriptions in this chapter use the 64-pin as an example.

### 9.1 Functions of Clock Output/Buzzer Output Controller

The clock output controller is intended for carrier output during remote controlled transmission and clock output for supply to peripheral ICs.

Buzzer output is a function to output a square wave of buzzer frequency.

One pin can be used to output a clock or buzzer sound.

Two output pins, PCLBUZ0 and PCLBUZ1, are available.

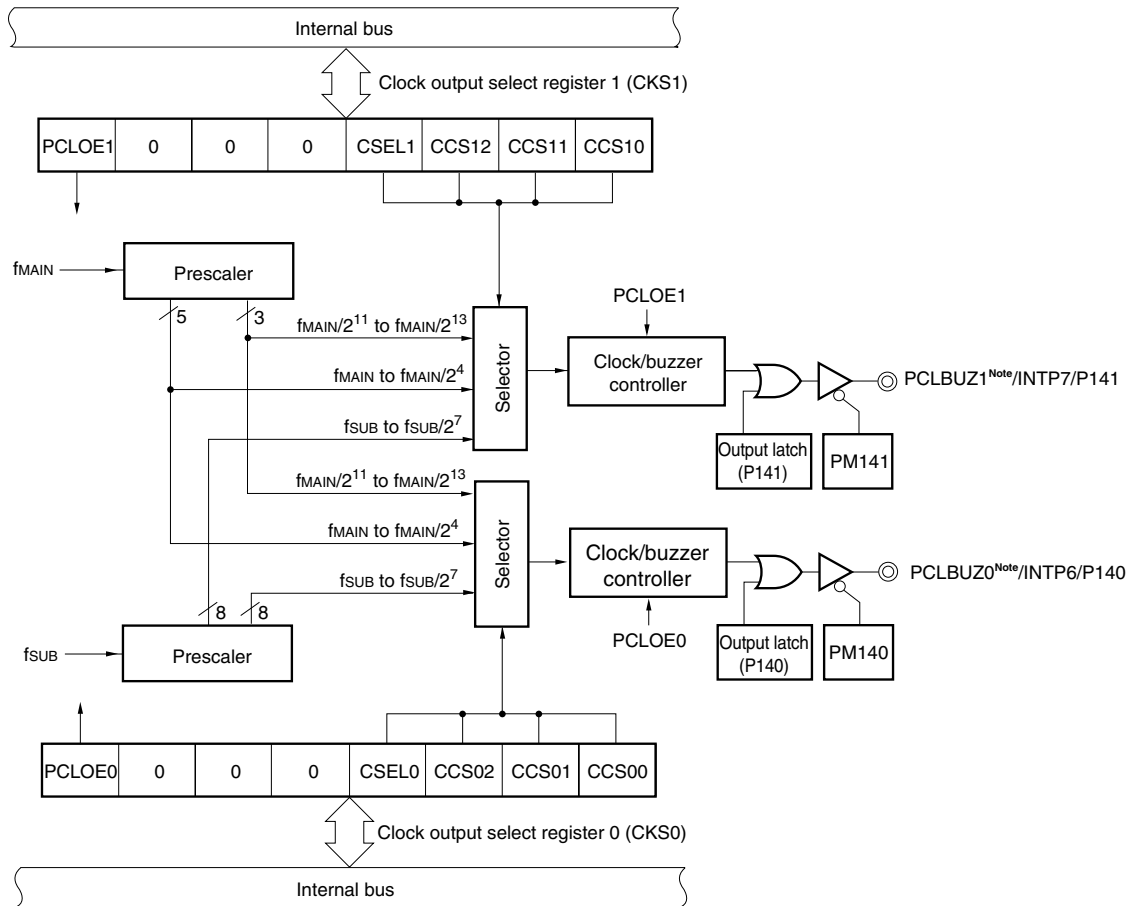
The PCLBUZn pin outputs a clock selected by clock output select register n (CKSn).

Figure 9-1 shows the block diagram of clock output/buzzer output controller.

**Caution** In the low-consumption RTC mode (when the RTCLPC bit of the operation speed mode control register (OSMC) = 1), it is not possible to output the subsystem clock ( $f_{SUB}$ ) from the PCLBUZn pin.

**Remark** n = 0, 1

Figure 9-1. Block Diagram of Clock Output/Buzzer Output Controller



<R> **Note** For output frequencies available from PCLBUZ0 and PCLBUZ1, refer 29.5 AC Characteristics.

<R> **Remark** The clock output/buzzer output pins in above diagram shows the information of 64- to 128-pins products with PIOR3 = 0 and PIOR4 = 0.  
 In other cases, the name of pins, output latches (Pxx) and PMxx should be read differently (xx = 15, 31, 55, 140 or 141).

## 9.2 Configuration of Clock Output/Buzzer Output Controller

The clock output/buzzer output controller includes the following hardware.

**Table 9-1. Configuration of Clock Output/Buzzer Output Controller**

Item	Configuration
Control registers	Clock output select registers n (CKSn) Port mode register 1, 3, 5, 14 (PM1, PM3, PM5, PM14) Port register 1, 3, 5, 14 (P1, P3, P5, P14)

## 9.3 Registers Controlling Clock Output/Buzzer Output Controller

The following two registers are used to control the clock output/buzzer output controller.

- Clock output select registers n (CKSn)
- Port mode register 1, 3, 5, 14 (PM1, PM3, PM5, PM14)

### (1) Clock output select registers n (CKSn)

These registers set output enable/disable for clock output or for the buzzer frequency output pin (PCLBUZn), and set the output clock.

Select the clock to be output from the PCLBUZn pin by using the CKSn register.

The CKSn register are set by a 1-bit or 8-bit memory manipulation instruction.

Reset signal generation clears these registers to 00H.

Figure 9-2. Format of Clock Output Select Register n (CKSn)

Address: FFFA5H (CKS0), FFFA6H (CKS1) After reset: 00H R/W

Symbol	<7>	6	5	4	3	2	1	0
CKSn	PCLOEn	0	0	0	CSELn	CCSn2	CCSn1	CCSn0

PCLOEn	PCLBUZn pin output enable/disable specification
0	Output disable (default)
1	Output enable

CSELn	CCSn2	CCSn1	CCSn0	PCLBUZn pin output clock selection				
				f <sub>MAIN</sub> = 5 MHz	f <sub>MAIN</sub> = 10 MHz	f <sub>MAIN</sub> = 20 MHz	f <sub>MAIN</sub> = 32 MHz	
0	0	0	0	f <sub>MAIN</sub>	5 MHz	10 MHz <sup>Note</sup>	Setting prohibited <sup>Note</sup>	Setting prohibited <sup>Note</sup>
0	0	0	1	f <sub>MAIN</sub> /2	2.5 MHz	5 MHz	10 MHz <sup>Note</sup>	16 MHz <sup>Note</sup>
0	0	1	0	f <sub>MAIN</sub> /2 <sup>2</sup>	1.25 MHz	2.5 MHz	5 MHz	8 MHz <sup>Note</sup>
0	0	1	1	f <sub>MAIN</sub> /2 <sup>3</sup>	625 kHz	1.25 MHz	2.5 MHz	4 MHz
0	1	0	0	f <sub>MAIN</sub> /2 <sup>4</sup>	312.5 kHz	625 kHz	1.25 MHz	2 MHz
0	1	0	1	f <sub>MAIN</sub> /2 <sup>11</sup>	2.44 kHz	4.88 kHz	9.76 kHz	15.63 kHz
0	1	1	0	f <sub>MAIN</sub> /2 <sup>12</sup>	1.22 kHz	2.44 kHz	4.88 kHz	7.81 kHz
0	1	1	1	f <sub>MAIN</sub> /2 <sup>13</sup>	610 Hz	1.22 kHz	2.44 kHz	3.91 kHz
1	0	0	0	f <sub>SUB</sub>	32.768 kHz			
1	0	0	1	f <sub>SUB</sub> /2	16.384 kHz			
1	0	1	0	f <sub>SUB</sub> /2 <sup>2</sup>	8.192 kHz			
1	0	1	1	f <sub>SUB</sub> /2 <sup>3</sup>	4.096 kHz			
1	1	0	0	f <sub>SUB</sub> /2 <sup>4</sup>	2.048 kHz			
1	1	0	1	f <sub>SUB</sub> /2 <sup>5</sup>	1.024 kHz			
1	1	1	0	f <sub>SUB</sub> /2 <sup>6</sup>	512 Hz			
1	1	1	1	f <sub>SUB</sub> /2 <sup>7</sup>	256 Hz			

<R> **Note** Use the output clock within a range of 16 MHz. Furthermore, when using the output clock at  $2.7\text{ V} \leq V_{DD} < 4.0\text{ V}$ , can be use it within 8 MHz only. See **29.5 AC Characteristics** for details.

- Cautions**
1. Change the output clock after disabling clock output (PCLOEn = 0).
  2. To shift to STOP mode when the main system clock is selected (CSELn = 0), set PCLOEn = 0 before executing the STOP instruction. When the subsystem clock is selected (CSELn = 1), PCLOEn = 1 can be set because the clock can be output in STOP mode.
  3. In the low-consumption RTC mode (when the RTCLPC bit of the operation speed mode control register (OSMC) = 1), it is not possible to output the subsystem clock (f<sub>SUB</sub>) from the PCLBUZn pin.

- Remarks**
1. n = 0, 1
  2. f<sub>MAIN</sub>: Main system clock frequency  
f<sub>SUB</sub>: Subsystem clock frequency

<R> **(2) Port mode register 1, 3, 5, 14 (PM1, PM3, PM5, PM14)**

These registers set input/output of port in 1-bit units.

For example in 64-pin products, when using the P140/INTP6/PCLBUZ0 and P141/INTP7/PCLBUZ1 pins for clock output and buzzer output clear PM140 and PM141 bits and the output latches of P140 and P141 to 0.

The PM1, PM3, PM5, PM14 registers can be set by a 1-bit or 8-bit memory manipulation instruction.

Reset signal generation sets these registers to FFH.

**Figure 9-3. Format of Port Mode Register 14 (PM14) (64-pin products)**

Address: FFF2EH After reset: FFH R/W

Symbol	7	6	5	4	3	2	1	0
PM14	PM147	PM146	1	1	1	1	PM141	PM140

PMmn	Pmn pin I/O mode selection (mn = 140, 141, 146, 147)
0	Output mode (output buffer on)
1	Input mode (output buffer off)

**Remark** For details of the port mode register other than 64-pin products, see **4.3 Registers Controlling Port Function**.

## 9.4 Operations of Clock Output/Buzzer Output Controller

One pin can be used to output a clock or buzzer sound.

The PCLBUZ0 pin outputs a clock/buzzer selected by the clock output select register 0 (CKS0).

The PCLBUZ1 pin outputs a clock/buzzer selected by the clock output select register 1 (CKS1).

### 9.4.1 Operation as output pin

The PCLBUZn pin is output as the following procedure.

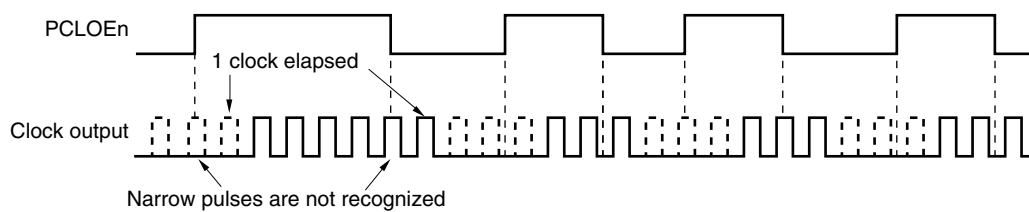
- <1> Select the output frequency with bits 0 to 3 (CCSn0 to CCSn2, CSELn) of the clock output select register (CKSn) of the PCLBUZn pin (output in disabled status).
- <2> Set bit 7 (PCLOEn) of the CKSn register to 1 to enable clock/buzzer output.

**Remarks 1.** The controller used for outputting the clock starts or stops outputting the clock one clock after enabling or disabling clock output (PCLOEn bit) is switched. At this time, pulses with a narrow width are not output.

Figure 9-4 shows enabling or stopping output using the PCLOEn bit and the timing of outputting the clock.

2. n = 0, 1

**Figure 9-4. Remote Control Output Application Example**



## CHAPTER 10 WATCHDOG TIMER

### 10.1 Functions of Watchdog Timer

The watchdog timer operates on the low-speed on-chip oscillator clock.

The watchdog timer is used to detect an inadvertent program loop. If a program loop is detected, an internal reset signal is generated.

Program loop is detected in the following cases.

- If the watchdog timer counter overflows
- If a 1-bit manipulation instruction is executed on the watchdog timer enable register (WDTE)
- If data other than "ACH" is written to the WDTE register
- If data is written to the WDTE register during a window close period

When a reset occurs due to the watchdog timer, bit 4 (WDTRF) of the reset control flag register (RESF) is set to 1. For details of the RESF register, see **CHAPTER 19 RESET FUNCTION**.

When 75% of the overflow time is reached, an interval interrupt can be generated.

### 10.2 Configuration of Watchdog Timer

The watchdog timer includes the following hardware.

**Table 10-1. Configuration of Watchdog Timer**

Item	Configuration
Control register	Watchdog timer enable register (WDTE)

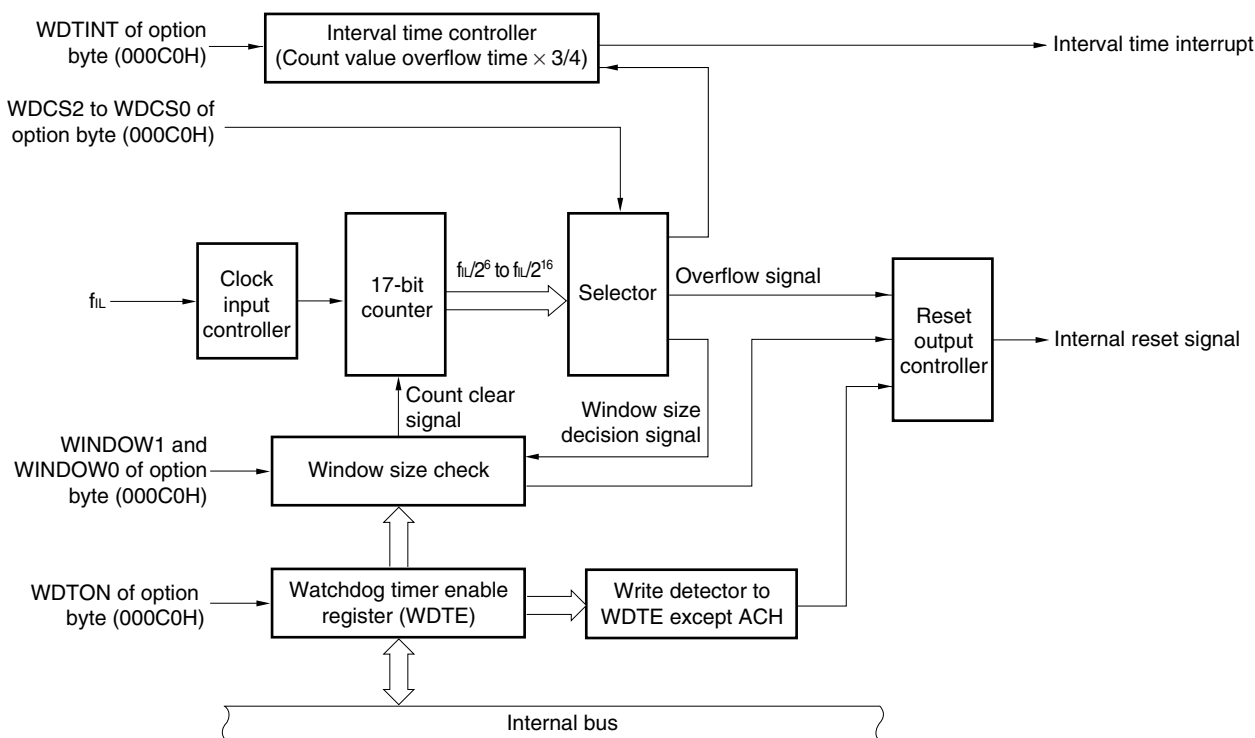
How the counter operation is controlled, overflow time, window open period, and interval interrupt are set by the option byte.

**Table 10-2. Setting of Option Bytes and Watchdog Timer**

Setting of Watchdog Timer	Option Byte (000C0H)
Watchdog timer interval interrupt	Bit 7 (WDTINT)
Window open period	Bits 6 and 5 (WINDOW1, WINDOW0)
Controlling counter operation of watchdog timer	Bit 4 (WDTON)
Overflow time of watchdog timer	Bits 3 to 1 (WDCS2 to WDCS0)
Controlling counter operation of watchdog timer (in HALT/STOP mode)	Bit 0 (WDSTBYON)

**Remark** For the option byte, see **CHAPTER 24 OPTION BYTE**.

**Figure 10-1. Block Diagram of Watchdog Timer**





### 10.3 Register Controlling Watchdog Timer

The watchdog timer is controlled by the watchdog timer enable register (WDTE).

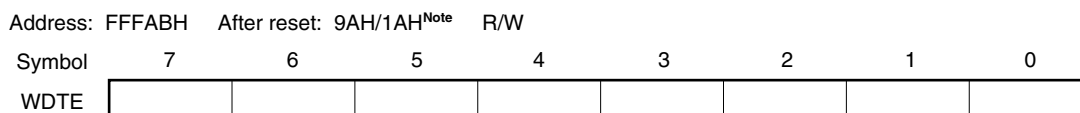
#### (1) Watchdog timer enable register (WDTE)

Writing “ACH” to the WDTE register clears the watchdog timer counter and starts counting again.

This register can be set by an 8-bit memory manipulation instruction.

Reset signal generation sets this register to 9AH or 1AH<sup>Note</sup>.

**Figure 10-2. Format of Watchdog Timer Enable Register (WDTE)**



**Note** The WDTE register reset value differs depending on the WDTON bit setting value of the option byte (000C0H). To operate watchdog timer, set the WDTON bit to 1.

WDTON Bit Setting Value	WDTE Register Reset Value
0 (watchdog timer count operation disabled)	1AH
1 (watchdog timer count operation enabled)	9AH

- Cautions**
1. If a value other than “ACH” is written to the WDTE register, an internal reset signal is generated.
  2. If a 1-bit memory manipulation instruction is executed for the WDTE register, an internal reset signal is generated.
  3. The value read from the WDTE register is 9AH/1AH (this differs from the written value (ACH)).

## 10.4 Operation of Watchdog Timer

### 10.4.1 Controlling operation of watchdog timer

1. When the watchdog timer is used, its operation is specified by the option byte (000C0H).
  - Enable counting operation of the watchdog timer by setting bit 4 (WDTON) of the option byte (000C0H) to 1 (the counter starts operating after a reset release) (for details, see **CHAPTER 24**).

WDTON	Watchdog Timer Counter
0	Counter operation disabled (counting stopped after reset)
1	Counter operation enabled (counting started after reset)

- Set an overflow time by using bits 3 to 1 (WDCS2 to WDCS0) of the option byte (000C0H) (for details, see **10.4.2** and **CHAPTER 24**).
  - Set a window open period by using bits 6 and 5 (WINDOW1 and WINDOW0) of the option byte (000C0H) (for details, see **10.4.3** and **CHAPTER 24**).
2. After a reset release, the watchdog timer starts counting.
  3. By writing “ACH” to the watchdog timer enable register (WDTE) after the watchdog timer starts counting and before the overflow time set by the option byte, the watchdog timer is cleared and starts counting again.
  4. After that, write the WDTE register the second time or later after a reset release during the window open period. If the WDTE register is written during a window close period, an internal reset signal is generated.
  5. If the overflow time expires without “ACH” written to the WDTE register, an internal reset signal is generated. An internal reset signal is generated in the following cases.
    - If a 1-bit manipulation instruction is executed on the WDTE register
    - If data other than “ACH” is written to the WDTE register

- Cautions**
1. When data is written to the watchdog timer enable register (WDTE) for the first time after reset release, the watchdog timer is cleared in any timing regardless of the window open time, as long as the register is written before the overflow time, and the watchdog timer starts counting again.
  2. If the watchdog timer is cleared by writing “ACH” to the WDTE register, the actual overflow time may be different from the overflow time set by the option byte by up to 2/f<sub>IL</sub> seconds.
  3. The watchdog timer can be cleared immediately before the count value overflows.

<R> **Cautions 4. The operation of the watchdog timer in the HALT and STOP and SNOOZE modes differs as follows depending on the set value of bit 0 (WDSTBYON) of the option byte (000C0H).**

	WDSTBYON = 0	WDSTBYON = 1
In HALT mode	Watchdog timer operation stops.	Watchdog timer operation continues.
In STOP mode		
In SNOOZE mode		

If **WDSTBYON = 0**, the watchdog timer resumes counting after the HALT or STOP mode is released. At this time, the counter is cleared to 0 and counting starts.

When operating with the X1 oscillation clock after releasing the STOP mode, the CPU starts operating after the oscillation stabilization time has elapsed.

Therefore, if the period between the STOP mode release and the watchdog timer overflow is short, an overflow occurs during the oscillation stabilization time, causing a reset.

Consequently, set the overflow time in consideration of the oscillation stabilization time when operating with the X1 oscillation clock and when the watchdog timer is to be cleared after the STOP mode release by an interval interrupt.

**10.4.2 Setting overflow time of watchdog timer**

Set the overflow time of the watchdog timer by using bits 3 to 1 (WDCS2 to WDCS0) of the option byte (000C0H).

If an overflow occurs, an internal reset signal is generated. The present count is cleared and the watchdog timer starts counting again by writing “ACH” to the watchdog timer enable register (WDTE) during the window open period before the overflow time.

The following overflow times can be set.

<R>

**Table 10-3. Setting of Overflow Time of Watchdog Timer**

WDCS2	WDCS1	WDCS0	Overflow Time of Watchdog Timer (f <sub>IL</sub> = 17.25 kHz (MAX.))
0	0	0	2 <sup>6</sup> /f <sub>IL</sub> (3.71 ms)
0	0	1	2 <sup>7</sup> /f <sub>IL</sub> (7.42 ms)
0	1	0	2 <sup>8</sup> /f <sub>IL</sub> (14.84 ms)
0	1	1	2 <sup>9</sup> /f <sub>IL</sub> (29.68 ms)
1	0	0	2 <sup>11</sup> /f <sub>IL</sub> (118.72 ms)
1	0	1	2 <sup>13</sup> /f <sub>IL</sub> (474.90 ms)
1	1	0	2 <sup>14</sup> /f <sub>IL</sub> (949.80 ms)
1	1	1	2 <sup>16</sup> /f <sub>IL</sub> (3799.19 ms)

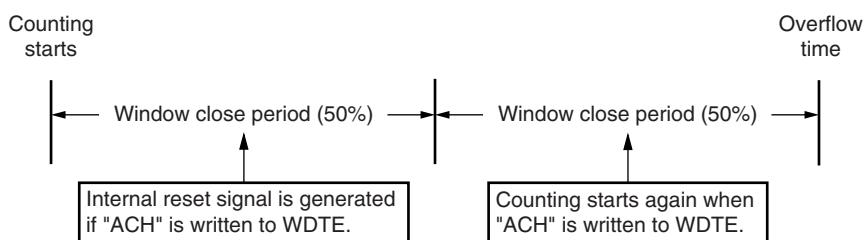
**Remark** f<sub>IL</sub>: Low-speed on-chip oscillator clock frequency

### 10.4.3 Setting window open period of watchdog timer

Set the window open period of the watchdog timer by using bits 6 and 5 (WINDOW1, WINDOW0) of the option byte (000C0H). The outline of the window is as follows.

- If "ACH" is written to the watchdog timer enable register (WDTE) during the window open period, the watchdog timer is cleared and starts counting again.
- Even if "ACH" is written to the WDTE register during the window close period, an abnormality is detected and an internal reset signal is generated.

**Example:** If the window open period is 50%



**Caution** When data is written to the WDTE register for the first time after reset release, the watchdog timer is cleared in any timing regardless of the window open time, as long as the register is written before the overflow time, and the watchdog timer starts counting again.

The window open period can be set is as follows.

**Table 10-4. Setting Window Open Period of Watchdog Timer**

WINDOW1	WINDOW0	Window Open Period of Watchdog Timer
0	0	Setting prohibited
0	1	50%
1	0	75%
1	1	100%

<R> **Caution** When bit 0 (WDSTBYON) of the option byte (000C0H) = 0, the window open period is 100% regardless of the values of the WINDOW1 and WINDOW0 bits.

**Remark** If the overflow time is set to  $2^9/f_{IL}$ , the window close time and open time are as follows.

	Setting of Window Open Period		
	50%	75%	100%
Window close time	0 to 20.08 ms	0 to 10.04 ms	None
Window open time	20.08 to 29.68 ms	10.04 to 29.68 ms	0 to 29.68 ms

<When window open period is 50%>

- Overflow time:  
 $2^9/f_{IL} \text{ (MAX.)} = 2^9/17.25 \text{ kHz} = 29.68 \text{ ms}$

<R> Window close time:  
 $0 \text{ to } 2^9/f_{IL} \text{ (MIN.)} \times (1 - 0.5) = 0 \text{ to } 2^9/12.75 \text{ kHz} \times 0.5 = 0 \text{ to } 20.08 \text{ ms}$

- Window open time:  
 $2^9/f_{IL} \text{ (MIN.)} \times (1 - 0.5) \text{ to } 2^9/f_{IL} \text{ (MAX.)} = 2^9/12.75 \text{ kHz} \times 0.5 \text{ to } 2^9/17.25 \text{ kHz} = 20.08 \text{ to } 29.68 \text{ ms}$

#### 10.4.4 Setting watchdog timer interval interrupt

Depending on the setting of bit 7 (WDTINT) of an option byte (000C0H), an interval interrupt (INTWDTI) can be generated when 75% of the overflow time is reached.

**Table 10-5. Setting of Watchdog Timer Interval Interrupt**

WDTINT	Use of Watchdog Timer Interval Interrupt
0	Interval interrupt is used.
1	Interval interrupt is generated when 75% of overflow time is reached.

**Caution** When operating with the X1 oscillation clock after releasing the STOP mode, the CPU starts operating after the oscillation stabilization time has elapsed. Therefore, if the period between the STOP mode release and the watchdog timer overflow is short, an overflow occurs during the oscillation stabilization time, causing a reset. Consequently, set the overflow time in consideration of the oscillation stabilization time when operating with the X1 oscillation clock and when the watchdog timer is to be cleared after the STOP mode release by an interval interrupt.

**Remark** The watchdog timer continues counting even after INTWDTI is generated (until ACH is written to the watchdog timer enable register (WDTE)). If ACH is not written to the WDTE register before the overflow time, an internal reset signal is generated.

**CHAPTER 11 A/D CONVERTER**

The number of analog input channels of the A/D converter differs, depending on the product.

	20, 24, 25-pin	30, 32-pin	36-pin	40-pin	44, 48-pin	52, 64-pin	80-pin	100-pin	128-pin
Analog input channels	6 ch (ANI0 to ANI2, ANI16 to ANI18)	8 ch (ANI0 to ANI3, ANI16 to ANI19)	8 ch (ANI0 to ANI5, ANI18, ANI19)	9 ch (ANI0 to ANI6, ANI18, ANI19)	10 ch (ANI0 to ANI7, ANI18, ANI19)	12 ch (ANI0 to ANI7, ANI16 to ANI19)	17 ch (ANI0 to ANI11, ANI16 to ANI20)	20 ch (ANI0 to ANI14, ANI16 to ANI20)	26 ch (ANI0 to ANI14, ANI16 to ANI26)

**11.1 Function of A/D Converter**

<R> The A/D converter is a 10-bit resolution<sup>Note</sup> converter that converts analog input signals into digital values, and is configured to control analog inputs, including up to 26 channels of A/D converter analog inputs (ANI0 to ANI14 and ANI16 to ANI26).

The A/D converter has the following function.

• **10-bit resolution A/D conversion<sup>Note</sup>**

10-bit resolution A/D conversion is carried out repeatedly for one analog input channel selected from ANI0 to ANI14 and ANI16 to ANI26. Each time an A/D conversion operation ends, an interrupt request (INTAD) is generated (when in the select mode).

**Note** 8-bit resolution can also be selected by using the ADTYP bit of A/D converter mode register 2 (ADM2).

Various A/D conversion modes can be specified by using the mode combinations below.

Trigger Mode	Channel Selection Mode	Conversion Operation Mode
<ul style="list-style-type: none"> <li>• Software trigger Conversion is started by specifying a software trigger.</li> <li>• Hardware trigger no-wait mode Conversion is started by detecting a hardware trigger.</li> <li>• Hardware trigger wait mode The power is turned on by detecting a hardware trigger while the system is off and in the conversion standby state, and conversion is then started automatically after the stabilization wait time passes.</li> </ul>	<ul style="list-style-type: none"> <li>• Select mode A/D conversion is performed on the analog input of one channel.</li> <li>• Scan mode A/D conversion is performed on the analog input of four channels in order.</li> </ul>	<ul style="list-style-type: none"> <li>• One-shot conversion mode A/D conversion is performed on the selected channel once.</li> <li>• Sequential conversion mode A/D conversion is sequentially performed on the selected channels until it is stopped by software.</li> </ul>



## 11.2 Configuration of A/D Converter

The A/D converter includes the following hardware.

### <R> (1) ANI0 to ANI14 and ANI16 to ANI26 pins

These are the analog input pins of the 26 channels of the A/D converter. They input analog signals to be converted into digital signals. Pins other than the one selected as the analog input pin can be used as I/O port pins.

### (2) Sample & hold circuit

The sample & hold circuit samples each of the analog input voltages sequentially sent from the input circuit, and sends them to the A/D voltage comparator. This circuit also holds the sampled analog input voltage during A/D conversion.

### (3) A/D voltage comparator

This A/D voltage comparator compares the voltage generated from the voltage tap of the comparison voltage generator with the analog input voltage. If the analog input voltage is found to be greater than the reference voltage ( $1/2 AV_{REF}$ ) as a result of the comparison, the most significant bit (MSB) of the successive approximation register (SAR) is set. If the analog input voltage is less than the reference voltage ( $1/2 AV_{REF}$ ), the MSB bit of the SAR is reset.

After that, bit 8 of the SAR register is automatically set, and the next comparison is made. The voltage tap of the comparison voltage generator is selected by the value of bit 9, to which the result has been already set.

Bit 9 = 0: ( $1/4 AV_{REF}$ )

Bit 9 = 1: ( $3/4 AV_{REF}$ )

The voltage tap of the comparison voltage generator and the analog input voltage are compared and bit 8 of the SAR register is manipulated according to the result of the comparison.

Analog input voltage  $\geq$  Voltage tap of comparison voltage generator: Bit 8 = 1

Analog input voltage  $\leq$  Voltage tap of comparison voltage generator: Bit 8 = 0

Comparison is continued like this to bit 0 of the SAR register.

When performing A/D conversion at a resolution of 8 bits, the comparison continues until bit 2 of the SAR register.

<R> **Remark**  $AV_{REF}$ : The + side reference voltage of the A/D converter. This can be selected from  $AV_{REFP}$ , the internal reference voltage (1.45 V), and  $V_{DD}$ .

### (4) Comparison voltage generator

The comparison voltage generator generates the comparison voltage input from an analog input pin.



**(5) Successive approximation register (SAR)**

<R> The SAR register is a register that sets voltage tap data whose values from the comparison voltage generator match the voltage values of the analog input pins, 1 bit at a time starting from the most significant bit (MSB).

If data is set in the SAR register all the way to the least significant bit (LSB) (end of A/D conversion), the contents of the SAR register (conversion results) are held in the A/D conversion result register (ADCR). When all the specified A/D conversion operations have ended, an A/D conversion end interrupt request signal (INTAD) is generated.

**(6) 10-bit A/D conversion result register (ADCR)**

The A/D conversion result is loaded from the successive approximation register to this register each time A/D conversion is completed, and the ADCR register holds the A/D conversion result in its higher 10 bits (the lower 6 bits are fixed to 0).

**(7) 8-bit A/D conversion result register (ADCRH)**

The A/D conversion result is loaded from the successive approximation register to this register each time A/D conversion is completed, and the ADCRH register stores the higher 8 bits of the A/D conversion result.

**(8) Controller**

This circuit controls the conversion time of an input analog signal that is to be converted into a digital signal, as well as starting and stopping of the conversion operation. When A/D conversion has been completed, this controller generates INTAD.

**(9) AV<sub>REFP</sub> pin**

This pin inputs an external reference voltage (AV<sub>REFP</sub>).

If using AV<sub>REFP</sub> as the + side reference voltage of the A/D converter, set the ADREFP1 and ADREFP0 bits of A/D converter mode register 2 (ADM2) to 1.

<R> The analog signals input to ANI0 to ANI14 and ANI16 to ANI26 are converted to digital signals based on the voltage applied between AV<sub>REFP</sub> and the – side reference voltage (AV<sub>REFM</sub>/V<sub>SS</sub>).

In addition to AV<sub>REFP</sub>, it is possible to select V<sub>DD</sub> or the internal reference voltage (1.45 V) as the + side reference voltage of the A/D converter.

**(10) AV<sub>REFM</sub> pin**

This pin inputs an external reference voltage (AV<sub>REFM</sub>). If using AV<sub>REFM</sub> as the – side reference voltage of the A/D converter, set the ADREFM bit of the ADM2 register to 1.

In addition to AV<sub>REFM</sub>, it is possible to select V<sub>SS</sub> as the – side reference voltage of the A/D converter.

### 11.3 Registers Used in A/D Converter

The A/D converter uses the following registers.

- Peripheral enable register 0 (PER0)
- A/D converter mode register 0 (ADM0)
- A/D converter mode register 1 (ADM1)
- A/D converter mode register 2 (ADM2)
- 10-bit A/D conversion result register (ADCR)
- 8-bit A/D conversion result register (ADCRH)
- Analog input channel specification register (ADS)
- Conversion result comparison upper limit setting register (ADUL)
- Conversion result comparison lower limit setting register (ADLL)
- A/D test register (ADTES)
- A/D port configuration register (ADPC)
- <R> • Port mode control registers 0, 3, 10, 11, 12, and 14 (PMC0, PMC3, PMC10, PMC11, PMC12, PMC14)
- <R> • Port mode registers 0, 2, 3, 10, 11, 12, 14, and 15 (PM0, PM2, PM3, PM10, PM11, PM12, PM14, PM15)

**(1) Peripheral enable register 0 (PER0)**

This register is used to enable or disable supplying the clock to the peripheral hardware. Clock supply to a hardware macro that is not used is stopped in order to reduce the power consumption and noise.

When the A/D converter is used, be sure to set bit 5 (ADCEN) of this register to 1.

The PER0 register can be set by a 1-bit or 8-bit memory manipulation instruction.

Reset signal generation clears this register to 00H.

**Figure 11-2. Format of Peripheral Enable Register 0 (PER0)**

Address: F00F0H After reset: 00H R/W

Symbol	<7>	<6>	<5>	<4>	<3>	<2>	<1>	<0>
PER0	RTCEN	IICA1EN <sup>Note 1</sup>	ADCEN	IICA0EN <sup>Note 2</sup>	SAU1EN <sup>Note 3</sup>	SAU0EN	TAU1EN <sup>Note 1</sup>	TAU0EN

ADCEN	Control of A/D converter input clock supply
0	Stops input clock supply. <ul style="list-style-type: none"> <li>• SFR used by the A/D converter cannot be written.</li> <li>• The A/D converter is in the reset status.</li> </ul>
1	Enables input clock supply. <ul style="list-style-type: none"> <li>• SFR used by the A/D converter can be read/written.</li> </ul>

- Notes**
1. 80, 100, and 128-pin products only.
  2. This is not provided in the 20-pin products.
  3. This is not provided in the 20, 24, and 25-pin products.

**Cautions**

1. When setting the A/D converter, be sure to set the ADCEN bit to 1 first. If ADCEN = 0, writing to a control register of the A/D converter is ignored, and, even if the register is read, only the default value is read (except for port mode registers 0, 2, 12, and 14 (PM0, PM2, PM12, PM14), port mode control registers 0, 12, and 14 (PMC0, PMC12, PMC14), and A/D port configuration register (ADPC)).

2. Be sure to clear the following bits to 0.
 

20-pin products:	bits 1, 3, 4, 6
24, 25-pin products:	bits 1, 3, 6
30, 32, 36, 40, 44, 48, 52, 64-pin products:	bits 1, 6

**(2) A/D converter mode register 0 (ADM0)**

This register sets the conversion time for analog input to be A/D converted, and starts/stops conversion. The ADM0 register can be set by a 1-bit or 8-bit memory manipulation instruction. Reset signal generation clears this register to 00H.

**Figure 11-3. Format of A/D Converter Mode Register 0 (ADM0)**

Address: FFF30H After reset: 00H R/W

Symbol <7> 6 5 4 3 2 1 <0>

ADM0	ADCS	ADMD	FR2 <sup>Note 1</sup>	FR1 <sup>Note 1</sup>	FR0 <sup>Note 1</sup>	LV1 <sup>Note 1</sup>	LV0 <sup>Note 1</sup>	ADCE
------	------	------	-----------------------	-----------------------	-----------------------	-----------------------	-----------------------	------

ADCS	A/D conversion operation control
0	Stops conversion operation [When read] Conversion stopped/standby status
1	Enables conversion operation [When read <sup>Note 2</sup> ] While in the software trigger mode: Conversion operation status While in the hardware trigger wait mode: Stabilization wait status + conversion operation status

ADMD	Specification of the A/D conversion channel selection mode
0	Select mode
1	Scan mode

ADCE	A/D voltage comparator operation control <sup>Note 3</sup>
0	Stops A/D voltage comparator operation
1	Enables A/D voltage comparator operation

- Notes**
1. For details of the FR2 to FR0, LV1, LV0 bits, and A/D conversion, see **Table 11-3 A/D Conversion Time Selection**.
  2. While in the software trigger mode or hardware trigger wait mode, the ADCS bit can be used as a status flag for the conversion operation status. However, while in the hardware trigger no-wait mode, this bit cannot be used as a status flag.
  3. While in the software trigger mode or hardware trigger no-wait mode, the operation of the A/D voltage comparator is controlled by the ADCS and ADCE bits, and it takes 1  $\mu$ s from the start of operation for the operation to stabilize. Therefore, when the ADCS bit is set to 1 after 1  $\mu$ s or more has elapsed from the time ADCE bit is set to 1, the conversion result at that time has priority over the first conversion result. Otherwise, ignore data of the first conversion.

**Table 11-1. Settings of ADCS and ADCE Bits**

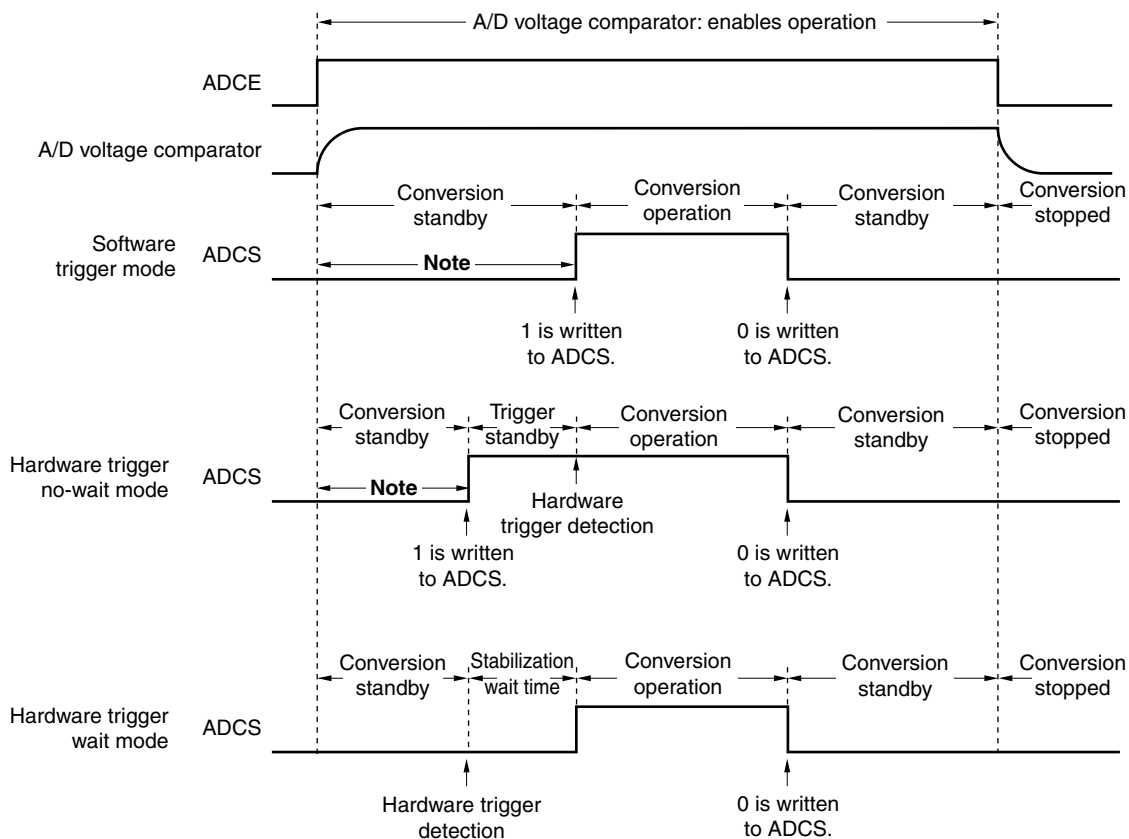
ADCS	ADCE	A/D Conversion Operation
0	0	Stop status (DC power consumption path does not exist)
0	1	Conversion standby mode (only A/D voltage comparator consumes power <sup>Note</sup> )
1	0	Setting prohibited
1	1	Conversion mode (A/D voltage comparator: enables operation)

<R> **Note** In hardware trigger wait mode, there is no DC power consumption path even during conversion standby mode.

**Table 11-2. Setting and Clearing Conditions for ADCS Bit**

A/D Conversion Mode			Set Conditions	Clear Conditions
Software trigger	Select mode	Sequential conversion mode	When 1 is written to ADCS	When 0 is written to ADCS
		One-shot conversion mode		<ul style="list-style-type: none"> <li>When 0 is written to ADCS</li> <li>The bit is automatically cleared to 0 when A/D conversion ends.</li> </ul>
	Scan mode	Sequential conversion mode		When 0 is written to ADCS
		One-shot conversion mode		<ul style="list-style-type: none"> <li>When 0 is written to ADCS</li> <li>The bit is automatically cleared to 0 when conversion ends on the specified four channels.</li> </ul>
Hardware trigger no-wait mode	Select mode	Sequential conversion mode	When a hardware trigger is input	When 0 is written to ADCS
		One-shot conversion mode		When 0 is written to ADCS
	Scan mode	Sequential conversion mode		When 0 is written to ADCS
		One-shot conversion mode		When 0 is written to ADCS
Hardware trigger wait mode	Select mode	Sequential conversion mode	When a hardware trigger is input	When 0 is written to ADCS
		One-shot conversion mode		<ul style="list-style-type: none"> <li>When 0 is written to ADCS</li> <li>The bit is automatically cleared to 0 when A/D conversion ends.</li> </ul>
	Scan mode	Sequential conversion mode		When 0 is written to ADCS
		One-shot conversion mode		<ul style="list-style-type: none"> <li>When 0 is written to ADCS</li> <li>The bit is automatically cleared to 0 when conversion ends on the specified four channels.</li> </ul>

Figure 11-4. Timing Chart When A/D Voltage Comparator Is Used



**Note** While in the software trigger mode or hardware trigger no-wait mode, the time from the rising of the ADCE bit to the falling of the ADCS bit must be 1  $\mu$ s or longer to stabilize the internal circuit.

- Cautions**
1. If using the hardware trigger wait mode, setting the ADCS bit to 1 is prohibited (but the bit is automatically switched to 1 when the hardware trigger signal is detected). However, it is possible to clear the ADCS bit to 0 to specify the A/D conversion standby status.
  2. While in the one-shot conversion mode of the hardware trigger no-wait mode, the ADCS flag is not automatically cleared to 0 when A/D conversion ends. Instead, 1 is retained.
  3. Only rewrite the value of the ADCE bit when ADCS = 0 (while in the conversion stopped/conversion standby status).

Table 11-3. A/D Conversion Time Selection (1/8)

(1) 3.6 V ≤ V<sub>DD</sub> ≤ 5.5 V

When there is no stabilization wait time (software trigger mode/hardware trigger no-wait mode)

A/D Converter Mode Register 0 (ADM0)					Mode	Conversion Time Selection						Conversion Clock (f <sub>AD</sub> )				
FR2	FR1	FR0	LV1	LV0		f <sub>CLK</sub> = 1 MHz	f <sub>CLK</sub> = 2 MHz	f <sub>CLK</sub> = 4 MHz	f <sub>CLK</sub> = 8 MHz	f <sub>CLK</sub> = 16 MHz	f <sub>CLK</sub> = 32 MHz					
0	0	0	0	0	Normal 1	Setting prohibited	Setting prohibited	Setting prohibited	Setting prohibited	Setting prohibited	38 μs	f <sub>CLK</sub> /64				
0	0	1									38 μs	19 μs	f <sub>CLK</sub> /32			
0	1	0									38 μs	19 μs	9.5 μs	f <sub>CLK</sub> /16		
0	1	1									38 μs	19 μs	9.5 μs	4.75 μs	f <sub>CLK</sub> /8	
1	0	0									28.5 μs	14.25 μs	7.125 μs	3.5625 μs	f <sub>CLK</sub> /6	
1	0	1									23.75 μs	11.875 μs	5.938 μs	2.9688 μs	f <sub>CLK</sub> /5	
1	1	0									38 μs	19 μs	9.5 μs	4.75 μs	2.375 μs	f <sub>CLK</sub> /4
1	1	1									38 μs	19 μs	9.5 μs	4.75 μs	2.375 μs	Setting prohibited
0	0	0			0	1	Normal 2	Setting prohibited	Setting prohibited	Setting prohibited	Setting prohibited	Setting prohibited	34 μs	f <sub>CLK</sub> /64		
0	0	1			34 μs	17 μs							f <sub>CLK</sub> /32			
0	1	0			34 μs	17 μs							8.5 μs	f <sub>CLK</sub> /16		
0	1	1			34 μs	17 μs							8.5 μs	4.25 μs	f <sub>CLK</sub> /8	
1	0	0			25.5 μs	12.75 μs							6.375 μs	3.1875 μs	f <sub>CLK</sub> /6	
1	0	1			21.25 μs	10.625 μs							5.3125 μs	2.6563 μs	f <sub>CLK</sub> /5	
1	1	0			34 μs	17 μs							8.5 μs	4.25 μs	2.125 μs	f <sub>CLK</sub> /4
1	1	1			34 μs	17 μs							8.5 μs	4.25 μs	2.125 μs	Setting prohibited
×	×	×			1	0	Low-voltage 1	Setting prohibited						–		
×	×	×	1	1	Low-voltage 2	Setting prohibited						–				

- Cautions**
1. When rewriting the FR2 to FR0, LV1, and LV0 bits to other than the same data, stop A/D conversion once (ADCS = 0) beforehand.
  2. The above conversion time does not include clock frequency errors. Select conversion time, taking clock frequency errors into consideration.

**Remark** f<sub>CLK</sub>: CPU/peripheral hardware clock frequency

**Table 11-3. A/D Conversion Time Selection (2/8)**

**(2) 2.7 V ≤ V<sub>DD</sub> < 3.6 V when there is no stabilization wait time (software trigger mode/hardware trigger no-wait mode)**

A/D Converter Mode Register 0 (ADM0)					Mode	Conversion Time Selection						Conversion Clock (f <sub>AD</sub> )		
FR2	FR1	FR0	LV1	LV0		f <sub>CLK</sub> = 1 MHz	f <sub>CLK</sub> = 2 MHz	f <sub>CLK</sub> = 4 MHz	f <sub>CLK</sub> = 8 MHz	f <sub>CLK</sub> = 16 MHz	f <sub>CLK</sub> = 32 MHz			
0	0	0	0	0	Normal 1	Setting prohibited	Setting prohibited	Setting prohibited	Setting prohibited	Setting prohibited	38 μs	f <sub>CLK</sub> /64		
0	0	1								38 μs	19 μs	f <sub>CLK</sub> /32		
0	1	0								38 μs	19 μs	9.5 μs	f <sub>CLK</sub> /16	
0	1	1								38 μs	19 μs	9.5 μs	4.75 μs	f <sub>CLK</sub> /8
1	0	0								28.5 μs	14.25 μs	7.125 μs	3.5625 μs	f <sub>CLK</sub> /6
1	0	1								23.75 μs	11.875 μs	5.938 μs	Setting prohibited	f <sub>CLK</sub> /5
1	1	0								38 μs	19 μs	9.5 μs		4.75 μs
1	1	1								38 μs	19 μs	9.5 μs	4.75 μs	Setting prohibited
0	0	0			0	1	Normal 2	Setting prohibited	Setting prohibited	Setting prohibited	Setting prohibited	34 μs	f <sub>CLK</sub> /64	
0	0	1			34 μs	17 μs					f <sub>CLK</sub> /32			
0	1	0			34 μs	17 μs					8.5 μs	f <sub>CLK</sub> /16		
0	1	1			34 μs	17 μs					8.5 μs	4.25 μs	f <sub>CLK</sub> /8	
1	0	0			25.5 μs	12.75 μs					6.375 μs	3.1875 μs	f <sub>CLK</sub> /6	
1	0	1			21.25 μs	10.625 μs					5.3125 μs	Setting prohibited	f <sub>CLK</sub> /5	
1	1	0			34 μs	17 μs					8.5 μs		4.25 μs	f <sub>CLK</sub> /4
1	1	1			34 μs	17 μs					8.5 μs	4.25 μs	Setting prohibited	f <sub>CLK</sub> /2
0	0	0			1	0	Low-voltage 1	Setting prohibited	Setting prohibited	Setting prohibited	Setting prohibited	38 μs	f <sub>CLK</sub> /64	
0	0	1			38 μs	19 μs					f <sub>CLK</sub> /32			
0	1	0			38 μs	19 μs					Setting prohibited	Setting prohibited	f <sub>CLK</sub> /16	
0	1	1			38 μs	19 μs							f <sub>CLK</sub> /8	
1	0	0			28.5 μs	14.25 μs					Setting prohibited	Setting prohibited	f <sub>CLK</sub> /6	
1	0	1			23.75 μs	11.875 μs							f <sub>CLK</sub> /5	
1	1	0			38 μs	19 μs					f <sub>CLK</sub> /4			
1	1	1			38 μs	19 μs					Setting prohibited	f <sub>CLK</sub> /2		
0	0	0			1	1	Low-voltage 2	Setting prohibited	Setting prohibited	Setting prohibited	Setting prohibited	34 μs	f <sub>CLK</sub> /64	
0	0	1			34 μs	17 μs					f <sub>CLK</sub> /32			
0	1	0			34 μs	17 μs					Setting prohibited	Setting prohibited	Setting prohibited	f <sub>CLK</sub> /16
0	1	1			34 μs	17 μs								f <sub>CLK</sub> /8
1	0	0			25.5 μs	12.75 μs					Setting prohibited	Setting prohibited	f <sub>CLK</sub> /6	
1	0	1			21.25 μs	10.625 μs							f <sub>CLK</sub> /5	
1	1	0			34 μs	17 μs					f <sub>CLK</sub> /4			
1	1	1			34 μs	17 μs					Setting prohibited	f <sub>CLK</sub> /2		

**Note** This value is prohibited when using the temperature sensor

- Cautions**
1. When rewriting the FR2 to FR0, LV1, and LV0 bits to other than the same data, stop A/D conversion once (ADCS = 0) beforehand.
  2. The above conversion time does not include clock frequency errors. Select conversion time, taking clock frequency errors into consideration.

**Remark** f<sub>CLK</sub>: CPU/peripheral hardware clock frequency



<R>

**Table 11-3. A/D Conversion Time Selection (3/8)**

**(3) 1.8 V ≤ V<sub>DD</sub> < 2.7 V when there is no stabilization wait time (software trigger mode/hardware trigger no-wait mode)**

A/D Converter Mode Register 0 (ADM0)					Mode	Conversion Time Selection						Conversion Clock (f <sub>AD</sub> )				
FR2	FR1	FR0	LV1	LV0		f <sub>CLK</sub> = 1 MHz	f <sub>CLK</sub> = 2 MHz	f <sub>CLK</sub> = 4 MHz	f <sub>CLK</sub> = 8 MHz	f <sub>CLK</sub> = 16 MHz <sup>Note</sup>	f <sub>CLK</sub> = 32 MHz					
0	0	0	0	0	Normal 1	Setting prohibited	Setting prohibited	Setting prohibited	Setting prohibited	Setting prohibited	Setting prohibited	f <sub>CLK</sub> /64				
0	0	1										f <sub>CLK</sub> /32				
0	1	0										f <sub>CLK</sub> /16				
0	1	1										f <sub>CLK</sub> /8				
1	0	0										f <sub>CLK</sub> /6				
1	0	1										f <sub>CLK</sub> /5				
1	1	0										f <sub>CLK</sub> /4				
1	1	1										f <sub>CLK</sub> /2				
0	0	0	0	1	Normal 2	Setting prohibited	Setting prohibited	Setting prohibited	Setting prohibited	Setting prohibited	Setting prohibited	f <sub>CLK</sub> /64				
0	0	1										f <sub>CLK</sub> /32				
0	1	0										f <sub>CLK</sub> /16				
0	1	1										f <sub>CLK</sub> /8				
1	0	0										f <sub>CLK</sub> /6				
1	0	1										f <sub>CLK</sub> /5				
1	1	0										f <sub>CLK</sub> /4				
1	1	1										f <sub>CLK</sub> /2				
0	0	0	1	0	Low-voltage 1	Setting prohibited	Setting prohibited	Setting prohibited	Setting prohibited	Setting prohibited	38 μs	f <sub>CLK</sub> /64				
0	0	1										38 μs	19 μs	f <sub>CLK</sub> /32		
0	1	0										38 μs	19 μs	Setting prohibited	Setting prohibited	f <sub>CLK</sub> /16
0	1	1										38 μs	19 μs	Setting prohibited		f <sub>CLK</sub> /8
1	0	0										28.5 μs	Setting prohibited	19 μs	Setting prohibited	f <sub>CLK</sub> /6
1	0	1										23.75 μs				f <sub>CLK</sub> /5
1	1	0										38 μs	19 μs	Setting prohibited	f <sub>CLK</sub> /4	
1	1	1										38 μs	19 μs	Setting prohibited	f <sub>CLK</sub> /2	
0	0	0	1	1	Low-voltage 2	Setting prohibited	Setting prohibited	Setting prohibited	Setting prohibited	Setting prohibited	34 μs	f <sub>CLK</sub> /64				
0	0	1										34 μs	17 μs	f <sub>CLK</sub> /32		
0	1	0										34 μs	17 μs	Setting prohibited	Setting prohibited	f <sub>CLK</sub> /16
0	1	1										34 μs	17 μs	Setting prohibited		f <sub>CLK</sub> /8
1	0	0										25.5 μs	Setting prohibited	17 μs	Setting prohibited	f <sub>CLK</sub> /6
1	0	1										21.25 μs				f <sub>CLK</sub> /5
1	1	0										34 μs	17 μs	Setting prohibited	f <sub>CLK</sub> /4	
1	1	1										34 μs	17 μs	Setting prohibited	f <sub>CLK</sub> /2	

**Note** Setting is prohibited when V<sub>DD</sub> < 2.4 V.

**Cautions 1.** When rewriting the FR2 to FR0, LV1, and LV0 bits to other than the same data, stop A/D conversion once (ADCS = 0) beforehand.

**2.** The above conversion time does not include clock frequency errors. Select conversion time, taking clock frequency errors into consideration.

**Remark** f<sub>CLK</sub>: CPU/peripheral hardware clock frequency

<R>

**Table 11-3. A/D Conversion Time Selection (4/8)**

**(4) 1.6 V ≤ V<sub>DD</sub> < 2.7 V when there is no stabilization wait time (software trigger mode/hardware trigger no-wait mode)**

A/D Converter Mode Register 0 (ADM0)					Mode	Conversion Time Selection						Conversion Clock (f <sub>AD</sub> )
FR2	FR1	FR0	LV1	LV0		f <sub>CLK</sub> = 1 MHz	f <sub>CLK</sub> = 2 MHz	f <sub>CLK</sub> = 4 MHz	f <sub>CLK</sub> = 8 MHz <sup>Note 1</sup>	f <sub>CLK</sub> = 16 MHz <sup>Note 2</sup>	f <sub>CLK</sub> = 32 MHz	
0	0	0	0	0	Normal 1	Setting prohibited	Setting prohibited	Setting prohibited	Setting prohibited	Setting prohibited	Setting prohibited	f <sub>CLK</sub> /64
0	0	1										f <sub>CLK</sub> /32
0	1	0										f <sub>CLK</sub> /16
0	1	1										f <sub>CLK</sub> /8
1	0	0										f <sub>CLK</sub> /6
1	0	1										f <sub>CLK</sub> /5
1	1	0										f <sub>CLK</sub> /4
1	1	1										f <sub>CLK</sub> /2
0	0	0	0	1	Normal 2	Setting prohibited	Setting prohibited	Setting prohibited	Setting prohibited	Setting prohibited	Setting prohibited	f <sub>CLK</sub> /64
0	0	1										f <sub>CLK</sub> /32
0	1	0										f <sub>CLK</sub> /16
0	1	1										f <sub>CLK</sub> /8
1	0	0										f <sub>CLK</sub> /6
1	0	1										f <sub>CLK</sub> /5
1	1	0										f <sub>CLK</sub> /4
1	1	1										f <sub>CLK</sub> /2
0	0	0	1	0	Low-voltage 1	Setting prohibited	Setting prohibited	Setting prohibited	Setting prohibited	76 μs	Setting prohibited	f <sub>CLK</sub> /64
0	0	1										f <sub>CLK</sub> /32
0	1	0										f <sub>CLK</sub> /16
0	1	1										f <sub>CLK</sub> /8
1	0	0										f <sub>CLK</sub> /6
1	0	1										f <sub>CLK</sub> /5
1	1	0										f <sub>CLK</sub> /4
1	1	1										f <sub>CLK</sub> /2
0	0	0	1	1	Low-voltage 2	Setting prohibited	Setting prohibited	Setting prohibited	Setting prohibited	68 μs	Setting prohibited	f <sub>CLK</sub> /64
0	0	1										f <sub>CLK</sub> /32
0	1	0										f <sub>CLK</sub> /16
0	1	1										f <sub>CLK</sub> /8
1	0	0										f <sub>CLK</sub> /6
1	0	1										f <sub>CLK</sub> /5
1	1	0										f <sub>CLK</sub> /4
1	1	1										f <sub>CLK</sub> /2

- Notes 1.** Setting is prohibited when V<sub>DD</sub> < 1.8 V.  
**2.** Setting is prohibited when V<sub>DD</sub> < 2.4 V.

- Cautions 1.** When rewriting the FR2 to FR0, LV1, and LV0 bits to other than the same data, stop A/D conversion once (ADCS = 0) beforehand.  
**2.** The above conversion time does not include clock frequency errors. Select conversion time, taking clock frequency errors into consideration.

**Remark** f<sub>CLK</sub>: CPU/peripheral hardware clock frequency

Table 11-3. A/D Conversion Time Selection (5/8)

(5)  $3.6\text{ V} \leq V_{DD} \leq 5.5\text{ V}$  when there is stabilization wait time (hardware trigger wait mode)

A/D Converter Mode Register 0 (ADM0)					Mode	Conversion Time Selection						Conversion Clock ( $f_{AD}$ )			
FR2	FR1	FR0	LV1	LV0		$f_{CLK} = 1$ MHz	$f_{CLK} = 2$ MHz	$f_{CLK} = 4$ MHz	$f_{CLK} = 8$ MHz	$f_{CLK} = 16$ MHz	$f_{CLK} = 32$ MHz				
0	0	0	0	0	Normal 1	Setting prohibited	Setting prohibited	Setting prohibited	Setting prohibited	Setting prohibited	54 $\mu\text{s}$	$f_{CLK}/64$			
0	0	1									54 $\mu\text{s}$	27 $\mu\text{s}$	13.5 $\mu\text{s}$	6.75 $\mu\text{s}$	$f_{CLK}/32$
0	1	0									54 $\mu\text{s}$	27 $\mu\text{s}$	13.5 $\mu\text{s}$	6.75 $\mu\text{s}$	$f_{CLK}/16$
0	1	1									54 $\mu\text{s}$	27 $\mu\text{s}$	13.5 $\mu\text{s}$	6.75 $\mu\text{s}$	$f_{CLK}/8$
1	0	0									40.5 $\mu\text{s}$	20.25 $\mu\text{s}$	10.125 $\mu\text{s}$	5.0625 $\mu\text{s}$	$f_{CLK}/6$
1	0	1									33.75 $\mu\text{s}$	16.875 $\mu\text{s}$	8.4375 $\mu\text{s}$	4.2188 $\mu\text{s}$	$f_{CLK}/5$
1	1	0									54 $\mu\text{s}$	27 $\mu\text{s}$	13.5 $\mu\text{s}$	6.75 $\mu\text{s}$	$f_{CLK}/4$
1	1	1									54 $\mu\text{s}$	27 $\mu\text{s}$	13.5 $\mu\text{s}$	6.75 $\mu\text{s}$	3.375 $\mu\text{s}$
0	0	0	0	1	Normal 2	Setting prohibited	Setting prohibited	Setting prohibited	Setting prohibited	Setting prohibited	50 $\mu\text{s}$	$f_{CLK}/64$			
0	0	1									50 $\mu\text{s}$	25 $\mu\text{s}$	12.5 $\mu\text{s}$	6.25 $\mu\text{s}$	$f_{CLK}/32$
0	1	0									50 $\mu\text{s}$	25 $\mu\text{s}$	12.5 $\mu\text{s}$	6.25 $\mu\text{s}$	$f_{CLK}/16$
0	1	1									50 $\mu\text{s}$	25 $\mu\text{s}$	12.5 $\mu\text{s}$	6.25 $\mu\text{s}$	$f_{CLK}/8$
1	0	0									37.5 $\mu\text{s}$	18.75 $\mu\text{s}$	9.375 $\mu\text{s}$	4.6875 $\mu\text{s}$	$f_{CLK}/6$
1	0	1									31.25 $\mu\text{s}$	15.625 $\mu\text{s}$	7.8125 $\mu\text{s}$	3.90625 $\mu\text{s}$	$f_{CLK}/5$
1	1	0									50 $\mu\text{s}$	25 $\mu\text{s}$	12.5 $\mu\text{s}$	6.25 $\mu\text{s}$	$f_{CLK}/4$
1	1	1									50 $\mu\text{s}$	25 $\mu\text{s}$	12.5 $\mu\text{s}$	6.25 $\mu\text{s}$	3.125 $\mu\text{s}$
×	×	×	1	0	Low-voltage 1	Setting prohibited						–			
×	×	×	1	1	Low-voltage 2	Setting prohibited						–			

- Cautions**
1. When rewriting the FR2 to FR0, LV1, and LV0 bits to other than the same data, stop A/D conversion once (ADCS = 0) beforehand.
  2. The above conversion time does not include clock frequency errors. Select conversion time, taking clock frequency errors into consideration.
  3. While in the hardware trigger wait mode, the conversion time includes the time spent waiting for stabilization after the hardware trigger is detected.

**Remark**  $f_{CLK}$ : CPU/peripheral hardware clock frequency

**Table 11-3. A/D Conversion Time Selection (6/8)**  
**(6) 2.7 V ≤ V<sub>DD</sub> < 3.6 V when there is stabilization wait time (hardware trigger wait mode)**

A/D Converter Mode Register 0 (ADM0)					Mode	Conversion Time Selection						Conversion Clock (f <sub>AD</sub> )		
FR2	FR1	FR0	LV1	LV0		f <sub>CLK</sub> = 1 MHz	f <sub>CLK</sub> = 2 MHz	f <sub>CLK</sub> = 4 MHz	f <sub>CLK</sub> = 8 MHz	f <sub>CLK</sub> = 16 MHz	f <sub>CLK</sub> = 32 MHz			
0	0	0	0	0	Normal 1	Setting prohibited	Setting prohibited	Setting prohibited	Setting prohibited	Setting prohibited	54 μs	f <sub>CLK</sub> /64		
0	0	1								54 μs	27 μs	f <sub>CLK</sub> /32		
0	1	0								54 μs	27 μs	13.5 μs	f <sub>CLK</sub> /16	
0	1	1								54 μs	27 μs	13.5 μs	6.75 μs	f <sub>CLK</sub> /8
1	0	0								40.5 μs	20.25 μs	10.125 μs	5.0625 μs	f <sub>CLK</sub> /6
1	0	1								33.75 μs	16.875 μs	8.4375 μs	Setting prohibited	f <sub>CLK</sub> /5
1	1	0								54 μs	27 μs	13.5 μs		6.75 μs
1	1	1								54 μs	27 μs	13.5 μs	6.75 μs	Setting prohibited
0	0	0	0	1	Normal 2	Setting prohibited	Setting prohibited	Setting prohibited	Setting prohibited	Setting prohibited	50 μs	f <sub>CLK</sub> /64		
0	0	1								50 μs	25 μs	f <sub>CLK</sub> /32		
0	1	0								50 μs	25 μs	12.5 μs	f <sub>CLK</sub> /16	
0	1	1								50 μs	25 μs	12.5 μs	6.25 μs	f <sub>CLK</sub> /8
1	0	0								37.5 μs	18.75 μs	9.375 μs	4.6875 μs	f <sub>CLK</sub> /6
1	0	1								31.25 μs	15.625 μs	7.8125 μs	Setting prohibited	f <sub>CLK</sub> /5
1	1	0								50 μs	25 μs	12.5 μs		6.25 μs
1	1	1								50 μs	25 μs	12.5 μs	6.25 μs	Setting prohibited
0	0	0	1	0	Low-voltage 1	Setting prohibited	Setting prohibited	Setting prohibited	Setting prohibited	Setting prohibited	54 μs	f <sub>CLK</sub> /64		
0	0	1								54 μs	27 μs	f <sub>CLK</sub> /32		
0	1	0								54 μs	27 μs	Setting prohibited	Setting prohibited	f <sub>CLK</sub> /16
0	1	1								54 μs	27 μs			f <sub>CLK</sub> /8
1	0	0								40.5 μs	Setting prohibited	Setting prohibited	f <sub>CLK</sub> /6	
1	0	1								33.75 μs			f <sub>CLK</sub> /5	
1	1	0								54 μs	27 μs	f <sub>CLK</sub> /4		
1	1	1								54 μs	27 μs	Setting prohibited	f <sub>CLK</sub> /2	
0	0	0	1	1	Low-voltage 2	Setting prohibited	Setting prohibited	Setting prohibited	Setting prohibited	Setting prohibited	50 μs	f <sub>CLK</sub> /64		
0	0	1								50 μs	25 μs	f <sub>CLK</sub> /32		
0	1	0								50 μs	25 μs	Setting prohibited	Setting prohibited	f <sub>CLK</sub> /16
0	1	1								50 μs	25 μs			f <sub>CLK</sub> /8
1	0	0								37.5 μs	Setting prohibited	Setting prohibited	f <sub>CLK</sub> /6	
1	0	1								31.25 μs			f <sub>CLK</sub> /5	
1	1	0								50 μs	25 μs	f <sub>CLK</sub> /4		
1	1	1								50 μs	25 μs	Setting prohibited	f <sub>CLK</sub> /2	

- Cautions 1.** When rewriting the FR2 to FR0, LV1, and LV0 bits to other than the same data, stop A/D conversion once (ADCS = 0) beforehand.
- 2.** The above conversion time does not include clock frequency errors. Select conversion time, taking clock frequency errors into consideration.
- 3.** While in the hardware trigger wait mode, the conversion time includes the time spent waiting for stabilization after the hardware trigger is detected.

**Remark** f<sub>CLK</sub>: CPU/peripheral hardware clock frequency

<R>

**Table 11-3. A/D Conversion Time Selection (7/8)**  
**(7) 1.8 V ≤ V<sub>DD</sub> < 2.7 V when there is stabilization wait time (hardware trigger wait mode)**

A/D Converter Mode Register 0 (ADM0)					Mode	Conversion Time Selection						Conversion Clock (f <sub>AD</sub> )				
FR2	FR1	FR0	LV1	LV0		f <sub>CLK</sub> = 1 MHz	f <sub>CLK</sub> = 2 MHz	f <sub>CLK</sub> = 4 MHz	f <sub>CLK</sub> = 8 MHz	f <sub>CLK</sub> = 16 MHz	f <sub>CLK</sub> = 32 MHz					
0	0	0	0	0	Normal 1	Setting prohibited	Setting prohibited	Setting prohibited	Setting prohibited	Setting prohibited	Setting prohibited	f <sub>CLK</sub> /64				
0	0	1										f <sub>CLK</sub> /32				
0	1	0										f <sub>CLK</sub> /16				
0	1	1										f <sub>CLK</sub> /8				
1	0	0										f <sub>CLK</sub> /6				
1	0	1										f <sub>CLK</sub> /5				
1	1	0										f <sub>CLK</sub> /4				
1	1	1										f <sub>CLK</sub> /2				
0	0	0	0	1	Normal 2	Setting prohibited	Setting prohibited	Setting prohibited	Setting prohibited	Setting prohibited	Setting prohibited	f <sub>CLK</sub> /64				
0	0	1										f <sub>CLK</sub> /32				
0	1	0										f <sub>CLK</sub> /16				
0	1	1										f <sub>CLK</sub> /8				
1	0	0										f <sub>CLK</sub> /6				
1	0	1										f <sub>CLK</sub> /5				
1	1	0										f <sub>CLK</sub> /4				
1	1	1										f <sub>CLK</sub> /2				
0	0	0	1	0	Low-voltage 1	Setting prohibited	Setting prohibited	Setting prohibited	Setting prohibited	Setting prohibited	54 μs	f <sub>CLK</sub> /64				
0	0	1										54 μs	27 μs	f <sub>CLK</sub> /32		
0	1	0										54 μs	27 μs	Setting prohibited	Setting prohibited	f <sub>CLK</sub> /16
0	1	1										54 μs	27 μs			f <sub>CLK</sub> /8
1	0	0										40.5 μs	27 μs	Setting prohibited	Setting prohibited	f <sub>CLK</sub> /6
1	0	1										33.75 μs	27 μs			f <sub>CLK</sub> /5
1	1	0										54 μs	27 μs	Setting prohibited	Setting prohibited	f <sub>CLK</sub> /4
1	1	1										54 μs	27 μs			f <sub>CLK</sub> /2
0	0	0	1	1	Low-voltage 2	Setting prohibited	Setting prohibited	Setting prohibited	Setting prohibited	Setting prohibited	50 μs	f <sub>CLK</sub> /64				
0	0	1										50 μs	25 μs	f <sub>CLK</sub> /32		
0	1	0										50 μs	25 μs	Setting prohibited	Setting prohibited	f <sub>CLK</sub> /16
0	1	1										50 μs	25 μs			f <sub>CLK</sub> /8
1	0	0										37.5 μs	25 μs	Setting prohibited	Setting prohibited	f <sub>CLK</sub> /6
1	0	1										31.25 μs	25 μs			f <sub>CLK</sub> /5
1	1	0										50 μs	25 μs	Setting prohibited	Setting prohibited	f <sub>CLK</sub> /4
1	1	1										50 μs	25 μs			f <sub>CLK</sub> /2

**Note** Setting is prohibited when V<sub>DD</sub> < 2.4 V.

- Cautions**
1. When rewriting the FR2 to FR0, LV1, and LV0 bits to other than the same data, stop A/D conversion once (ADCS = 0) beforehand.
  2. The above conversion time does not include clock frequency errors. Select conversion time, taking clock frequency errors into consideration.
  3. While in the hardware trigger wait mode, the conversion time includes the time spent waiting for stabilization after the hardware trigger is detected.

**Remark** f<sub>CLK</sub>: CPU/peripheral hardware clock frequency

<R>

**Table 11-3. A/D Conversion Time Selection (8/8)**  
**(8) 1.6 V ≤ V<sub>DD</sub> < 1.8 V When there is stabilization wait time (hardware trigger wait mode)**

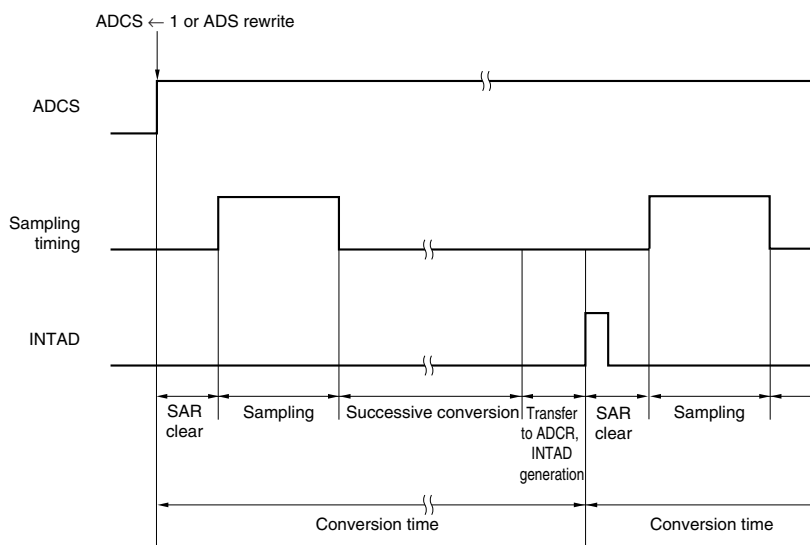
A/D Converter Mode Register 0 (ADM0)					Mode	Conversion Time Selection						Conversion Clock (f <sub>AD</sub> )
FR2	FR1	FR0	LV1	LV0		f <sub>CLK</sub> = 1 MHz	f <sub>CLK</sub> = 2 MHz	f <sub>CLK</sub> = 4 MHz	f <sub>CLK</sub> = 8 MHz	f <sub>CLK</sub> = 16 MHz	f <sub>CLK</sub> = 32 MHz	
0	0	0	0	0	Normal 1	Setting prohibited	Setting prohibited	Setting prohibited	Setting prohibited	Setting prohibited	Setting prohibited	f <sub>CLK</sub> /64
0	0	1				f <sub>CLK</sub> /32						
0	1	0				f <sub>CLK</sub> /16						
0	1	1				f <sub>CLK</sub> /8						
1	0	0				f <sub>CLK</sub> /6						
1	0	1				f <sub>CLK</sub> /5						
1	1	0				f <sub>CLK</sub> /4						
1	1	1				f <sub>CLK</sub> /2						
0	0	0	0	1	Normal 2	Setting prohibited	Setting prohibited	Setting prohibited	Setting prohibited	Setting prohibited	Setting prohibited	f <sub>CLK</sub> /64
0	0	1				f <sub>CLK</sub> /32						
0	1	0				f <sub>CLK</sub> /16						
0	1	1				f <sub>CLK</sub> /8						
1	0	0				f <sub>CLK</sub> /6						
1	0	1				f <sub>CLK</sub> /5						
1	1	0				f <sub>CLK</sub> /4						
1	1	1				f <sub>CLK</sub> /2						
0	0	0	1	0	Low-voltage 1	Setting prohibited	Setting prohibited	Setting prohibited	Setting prohibited	108 μs	Setting prohibited	f <sub>CLK</sub> /64
0	0	1				f <sub>CLK</sub> /32						
0	1	0				108 μs	Setting prohibited	f <sub>CLK</sub> /16				
0	1	1				108 μs	Setting prohibited	f <sub>CLK</sub> /8				
1	0	0				81 μs	Setting prohibited	f <sub>CLK</sub> /6				
1	0	1				135 μs	Setting prohibited	f <sub>CLK</sub> /5				
1	1	0				108 μs	Setting prohibited	f <sub>CLK</sub> /4				
1	1	1				Setting prohibited	Setting prohibited	f <sub>CLK</sub> /2				
0	0	0	1	1	Low-voltage 2	Setting prohibited	Setting prohibited	Setting prohibited	Setting prohibited	100 μs	Setting prohibited	f <sub>CLK</sub> /64
0	0	1				f <sub>CLK</sub> /32						
0	1	0				100 μs	Setting prohibited	f <sub>CLK</sub> /16				
0	1	1				100 μs	Setting prohibited	f <sub>CLK</sub> /8				
1	0	0				Setting prohibited	Setting prohibited	f <sub>CLK</sub> /6				
1	0	1				125 μs	Setting prohibited	f <sub>CLK</sub> /5				
1	1	0				100 μs	Setting prohibited	f <sub>CLK</sub> /4				
1	1	1				Setting prohibited	Setting prohibited	f <sub>CLK</sub> /2				

- Notes**
- Setting is prohibited when V<sub>DD</sub> < 1.8 V.
  - Setting is prohibited when V<sub>DD</sub> < 2.4 V.

- Cautions**
- When rewriting the FR2 to FR0, LV1, and LV0 bits to other than the same data, stop A/D conversion once (ADCS = 0) beforehand.
  - The above conversion time does not include clock frequency errors. Select conversion time, taking clock frequency errors into consideration.
  - While in the hardware trigger wait mode, the conversion time includes the time spent waiting for stabilization after the hardware trigger is detected.

**Remark** f<sub>CLK</sub>: CPU/peripheral hardware clock frequency

Figure 11-5. A/D Converter Sampling and A/D Conversion Timing (Example for Software Trigger Mode)



(3) A/D converter mode register 1 (ADM1)

This register is used to specify the A/D conversion trigger, conversion mode, and hardware trigger signal. The ADM1 register can be set by a 1-bit or 8-bit memory manipulation instruction. Reset signal generation clears this register to 00H.

Figure 11-6. Format of A/D Converter Mode Register 1 (ADM1)

Address: FFF32H After reset: 00H R/W

Symbol	7	6	5	4	3	2	1	0
ADM1	ADTMD1	ADTMD0	ADSCM	0	0	0	ADTRS1	ADTRS0

ADTMD1	ADTMD0	Selection of the A/D conversion trigger mode
0	–	Software trigger mode
1	0	Hardware trigger no-wait mode
1	1	Hardware trigger wait mode

ADSCM	Specification of the A/D conversion mode
0	Sequential conversion mode
1	One-shot conversion mode

ADTRS1	ADTRS0	Selection of the hardware trigger signal
0	0	End of timer channel 1 count or capture interrupt signal (INTTM01)
0	1	Setting prohibited
1	0	Real-time clock interrupt signal (INTRTC)
1	1	Interval timer interrupt signal (INTIT)

- Cautions**
1. Only rewrite the value of the ADM1 register while conversion operation is stopped (which is indicated by the ADCS bit of A/D converter mode register 0 (ADM0) being 0).
  2. For the trigger interval in the hardware trigger wait mode, specify at least “A/D Conversion Time, When there is stabilization wait time” described in Table 11-3.

**(4) A/D converter mode register 2 (ADM2)**

This register is used to select the A/D converter reference voltage, check the upper limit and lower limit A/D conversion result values, select the resolution, and specify whether to use the SNOOZE mode.

The ADM2 register can be set by a 1-bit or 8-bit memory manipulation instruction.

Reset signal generation clears this register to 00H.

**Figure 11-7. Format of A/D Converter Mode Register 2 (ADM2) (1/2)**

Address: F0010H After reset: 00H R/W

Symbol	7	6	5	4	<3>	<2>	1	<0>
<R> ADM2	ADREFP1	ADREFP0	ADREFM	0	ADRCK	AWC	0	ADTYP

ADREFP1	ADREFP0	Selection of the + side reference voltage source of the A/D converter
0	0	Supplied from V <sub>DD</sub>
0	1	Supplied from P20/AV <sub>REFP</sub> /ANI0
1	0	Supplied from the internal reference voltage (1.45 V)
1	1	Setting prohibited

<R>

- When ADREFP1 or ADREFP0 bit is rewritten, this must be configured in accordance with the following procedures.
  - Set ADCE = 0
  - Change the values of ADREFP1 and ADREFP0
  - Stabilization wait time (A)
  - Set ADCE = 1
  - Stabilization wait time (B)
 When ADREFP1 and ADREFP0 are set to 1 and 0, the setting is changed to A = 1 μs, B = 5 μs.  
 When ADREFP1 and ADREFP0 are set to 0 and 0 or 0 and 1, A needs no wait and B = 1 μs.
- When ADREFP1 and ADREFP0 are set to 1 and 0, respectively, A/D conversion cannot be performed on the temperature sensor output.  
 Be sure to perform A/D conversion while ADISS = 0.

ADREFM	Selection of the – side reference voltage source of the A/D converter
0	Supplied from V <sub>SS</sub>
1	Supplied from P21/AV <sub>REFM</sub> /ANI1

<R>

ADRCK	Checking the upper limit and lower limit conversion result values
0	The interrupt signal (INTAD) is output when the ADLL register ≤ the ADCR register ≤ the ADUL register (<1>).
1	The interrupt signal (INTAD) is output when the ADCR register < the ADLL register (<2>) or the ADUL register < the ADCR register (<3>).

Figure 11-8 shows the generation range of the interrupt signal (INTAD) for <1> to <3>.

**Caution** Only rewrite the value of the ADM2 register while conversion operation is stopped (which is indicated by the ADCS bit of A/D converter mode register 0 (ADM0) being 0).



Figure 11-7. Format of A/D Converter Mode Register 2 (ADM2) (2/2)

Address: F0010H After reset: 00H R/W

Symbol	7	6	5	4	<3>	<2>	1	<0>
ADM2	ADREFP1	ADREFP0	ADREFM	0	ADRCK	AWC	0	ADTYP

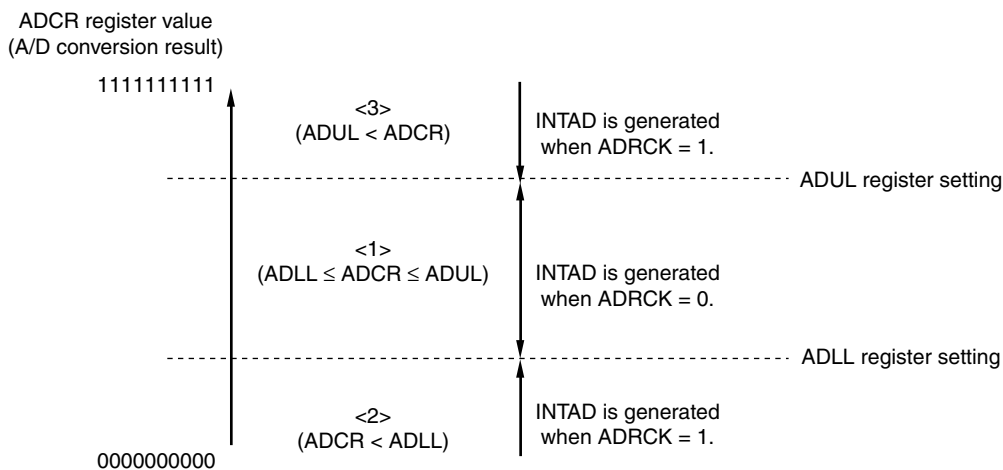
AWC	Specification of the SNOOZE mode
0	Do not use the SNOOZE mode function.
1	Use the SNOOZE mode function.
<p>When there is a hardware trigger signal in the STOP mode, the STOP mode is exited, and A/D conversion is performed without operating the CPU (the SNOOZE mode).</p> <ul style="list-style-type: none"> <li>The SNOOZE mode function can only be specified when the high-speed on-chip oscillator clock is selected for the CPU/peripheral hardware clock (<math>f_{CLK}</math>). If any other clock is selected, specifying this mode is prohibited.</li> <li>Using the SNOOZE mode function in the software trigger mode or hardware trigger no-wait mode is prohibited.</li> <li>Using the SNOOZE mode function in the sequential conversion mode is prohibited.</li> <li>When using the SNOOZE mode function, specify a hardware trigger interval of at least "A/D conversion time with stabilization wait time" listed for Table 11-3.</li> </ul>	

ADTYP	Selection of the A/D conversion resolution
0	10-bit resolution
1	8-bit resolution

**Caution** Only rewrite the value of the ADM2 register while conversion operation is stopped (which is indicated by the ADCS bit of A/D converter mode register 0 (ADM0) being 0).

<R>

Figure 11-8. ADRCK Bit Interrupt Signal Generation Range



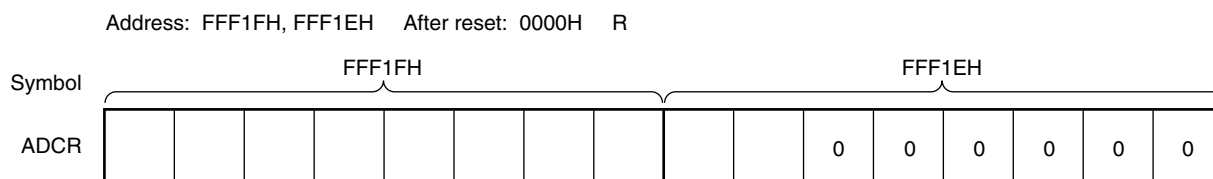
**(5) 10-bit A/D conversion result register (ADCR)**

This register is a 16-bit register that stores the A/D conversion result in the select mode. The lower 6 bits are fixed to 0. Each time A/D conversion ends, the conversion result is loaded from the successive approximation register (SAR). The higher 8 bits of the conversion result are stored in FFF1FH and the lower 2 bits are stored in the higher 2 bits of FFF1EH.

The ADCR register can be read by a 16-bit memory manipulation instruction.

Reset signal generation clears this register to 0000H.

**Figure 11-9. Format of 10-bit A/D Conversion Result Register (ADCR)**



- Cautions**
1. When writing to the A/D converter mode register 0 (ADM0), analog input channel specification register (ADS), and A/D port configuration register (ADPC), the contents of the ADCR register may become undefined. Read the conversion result following conversion completion before writing to the ADM0, ADS, and ADPC registers. Using timing other than the above may cause an incorrect conversion result to be read.
  2. When 8-bit resolution A/D conversion is selected (when the ADTYP bit of A/D converter mode register 2 (ADM2) is 1) and the ADCR register is read, 0 is read from the lower two bits (ADCR1 and ADCR0).
  3. When the ADCR register is accessed in 16-bit units, the higher 10 bits of the conversion result are read in order starting at bit 15.

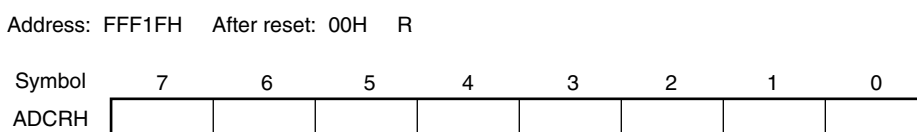
**(6) 8-bit A/D conversion result register (ADCRH)**

This register is an 8-bit register that stores the A/D conversion result. The higher 8 bits of 10-bit resolution are stored.

The ADCRH register can be read by an 8-bit memory manipulation instruction.

Reset signal generation clears this register to 00H.

**Figure 11-10. Format of 8-bit A/D Conversion Result Register (ADCRH)**



**Caution** When writing to the A/D converter mode register 0 (ADM0), analog input channel specification register (ADS), and A/D port configuration register (ADPC), the contents of the ADCRH register may become undefined. Read the conversion result following conversion completion before writing to the ADM0, ADS, and ADPC registers. Using timing other than the above may cause an incorrect conversion result to be read.

**(7) Analog input channel specification register (ADS)**

This register specifies the input channel of the analog voltage to be A/D converted.

The ADS register can be set by a 1-bit or 8-bit memory manipulation instruction.

Reset signal generation clears this register to 00H.

&lt;R&gt;

**Figure 11-11. Format of Analog Input Channel Specification Register (ADS) (1/2)**

Address: FFF31H After reset: 00H R/W

Symbol	7	6	5	4	3	2	1	0
ADS	ADISS	0	0	ADS4	ADS3	ADS2	ADS1	ADS0

○ Select mode (ADMD = 0)

ADISS	ADS4	ADS3	ADS2	ADS1	ADS0	Analog input channel	Input source
0	0	0	0	0	0	ANI0	P20/ANI0/AV <sub>REFP</sub> pin
0	0	0	0	0	1	ANI1	P21/ANI1/AV <sub>REFM</sub> pin
0	0	0	0	1	0	ANI2	P22/ANI2 pin
0	0	0	0	1	1	ANI3	P23/ANI3 pin
0	0	0	1	0	0	ANI4	P24/ANI4 pin
0	0	0	1	0	1	ANI5	P25/ANI5 pin
0	0	0	1	1	0	ANI6	P26/ANI6 pin
0	0	0	1	1	1	ANI7	P27/ANI7 pin
0	0	1	0	0	0	ANI8	P150/ANI8 pin
0	0	1	0	0	1	ANI9	P151/ANI9 pin
0	0	1	0	1	0	ANI10	P152/ANI10 pin
0	0	1	0	1	1	ANI11	P153/ANI11 pin
0	0	1	1	0	0	ANI12	P154/ANI12 pin
0	0	1	1	0	1	ANI13	P155/ANI13 pin
0	0	1	1	1	0	ANI14	P156/ANI14 pin
0	0	1	1	1	1	Setting prohibited	
0	1	0	0	0	0	ANI16	P03/ANI16 pin <sup>Note 1</sup>
0	1	0	0	0	1	ANI17	P02/ANI17 pin <sup>Note 2</sup>
0	1	0	0	1	0	ANI18	P147/ANI18 pin
0	1	0	0	1	1	ANI19	P120/ANI19 pin
0	1	0	1	0	0	ANI20	P100/ANI20 pin
0	1	0	1	0	1	ANI21	P37/ANI21 pin
0	1	0	1	1	0	ANI22	P36/ANI22 pin
0	1	0	1	1	1	ANI23	P35/ANI23 pin
0	1	1	0	0	0	ANI24	P117/ANI24 pin
0	1	1	0	0	1	ANI25	P116/ANI25 pin
0	1	1	0	1	0	ANI26	P115/ANI26 pin
0	1	1	0	1	1	Setting prohibited	
1	0	0	0	0	0	–	Temperature sensor output
1	0	0	0	0	1	–	Internal reference voltage output (1.45 V)
Other than the above						Setting prohibited	

**Notes 1.** 20-, 24-, 25-, 30-, 32-pin products: P01/ANI16 pin

**2.** 20-, 24-, 25-, 30-, 32-pin products: P00/ANI17 pin

<R>

**Figure 11-11. Format of Analog Input Channel Specification Register (ADS) (2/2)**

Address: FFF31H After reset: 00H R/W

Symbol	7	6	5	4	3	2	1	0
ADS	ADISS	0	0	ADS4	ADS3	ADS2	ADS1	ADS0

○ Scan mode (ADMD = 1)

ADISS	ADS4	ADS3	ADS2	ADS1	ADS0	Analog input channel			
						Scan 0	Scan 1	Scan 2	Scan 3
0	0	0	0	0	0	ANI0	ANI1	ANI2	ANI3
0	0	0	0	0	1	ANI1	ANI2	ANI3	ANI4
0	0	0	0	1	0	ANI2	ANI3	ANI4	ANI5
0	0	0	0	1	1	ANI3	ANI4	ANI5	ANI6
0	0	0	1	0	0	ANI4	ANI5	ANI6	ANI7
0	0	0	0	0	0	ANI5	ANI6	ANI7	ANI8
0	0	0	0	0	1	ANI6	ANI7	ANI8	ANI9
0	0	0	0	1	0	ANI7	ANI8	ANI9	ANI10
0	0	0	0	1	1	ANI8	ANI9	ANI10	ANI11
0	0	0	0	1	0	ANI9	ANI10	ANI11	ANI12
0	0	0	0	1	1	ANI10	ANI11	ANI12	ANI13
0	0	0	1	0	0	ANI11	ANI12	ANI13	ANI14
Other than the above						Setting prohibited			

- Cautions**
1. Be sure to clear bits 5 and 6 to 0.
  2. Set a channel to be used for A/D conversion in the input mode by using port mode registers 0, 2, 3, 10 to 12, 14, or 15 (PM0, PM2, PM3, PM10 to PM12, PM14, PM15).
  3. Do not set the pin that is set by the A/D port configuration register (ADPC) as digital I/O by the ADS register.
  4. Do not set the pin that is set by port mode control register 0, 3, 10 to 12, or 14 (PMC0, PMC3, PMC10 to PMC12, PMC14) as digital I/O by the ADS register.
  5. Only rewrite the value of the ADISS bit while conversion operation is stopped (which is indicated by the ADCE bit of A/D voltage cooperator mode register 0 (ADM0) being 0).
  6. If using AV<sub>REFP</sub> as the + side reference voltage source of the A/D converter, do not select ANI0 as an A/D conversion channel.
  7. If using AV<sub>REFM</sub> as the – side reference voltage source of the A/D converter, do not select ANI1 as an A/D conversion channel.
  8. If ADISS is set to 1, the internal reference voltage (1.45 V) cannot be used for the + side reference voltage source.

<R>

**Remark** x: don't care

**(8) Conversion result comparison upper limit setting register (ADUL)**

This register is used to specify the setting for checking the upper limit of the A/D conversion results.

The A/D conversion results and ADUL register value are compared, and interrupt signal (INTAD) generation is controlled in the range specified for the ADRCK bit of A/D converter mode register 2 (ADM2) (shown in **Figure 11-8**).

The ADUL register can be set by an 8-bit memory manipulation instruction.

Reset signal generation sets this register to FFH.

**Caution** When 10-bit resolution A/D conversion is selected, the higher eight bits of the 10-bit A/D conversion result register (ADCR) are compared with the ADUL register.

**Figure 11-12. Format of Conversion Result Comparison Upper Limit Setting Register (ADUL)**

Address: F0011H After reset: FFH R/W

Symbol	7	6	5	4	3	2	1	0
ADUL	ADUL7	ADUL6	ADUL5	ADUL4	ADUL3	ADUL2	ADUL1	ADUL0

**(9) Conversion result comparison lower limit setting register (ADLL)**

This register is used to specify the setting for checking the lower limit of the A/D conversion results.

The A/D conversion results and ADLL register value are compared, and interrupt signal (INTAD) generation is controlled in the range specified for the ADRCK bit of A/D converter mode register 2 (ADM2) (shown in **Figure 11-8**).

The ADLL register can be set by an 8-bit memory manipulation instruction.

Reset signal generation clears this register to 00H.

**Figure 11-13. Format of Conversion Result Comparison Lower Limit Setting Register (ADLL)**

Address: F0012H After reset: 00H R/W

Symbol	7	6	5	4	3	2	1	0
ADLL	ADLL7	ADLL6	ADLL5	ADLL4	ADLL3	ADLL2	ADLL1	ADLL0

**Caution** When 10-bit resolution A/D conversion is selected, the higher eight bits of the 10-bit A/D conversion result register (ADCR) are compared with the ADLL register.

**(10) A/D test register (ADTES)**

This register is used to select the + side reference voltage ( $AV_{REFP}$ ) or - side reference voltage ( $AV_{REFM}$ ) of the A/D converter, or the analog input channel ( $ANlxx$ ) as the A/D conversion target for the A/D test function.

The ADTES register can be set by an 8-bit memory manipulation instruction.

Reset signal generation clears this register to 00H.

&lt;R&gt;

**Figure 11-14. Format of A/D Test Register (ADTES)**

Address: F0013H After reset: 00H R/W

Symbol	7	6	5	4	3	2	1	0
ADTES	0	0	0	0	0	0	ADTES1	ADTES0

ADTES1	ADTES0	A/D conversion target
0	0	$ANlxx$ (This is specified using the analog input channel specification register (ADS).)
1	0	$AV_{REFM}$
1	1	$AV_{REFP}$
Other than the above		Setting prohibited

**(11) A/D port configuration register (ADPC)**

<R> This register switches the ANI0/P20 to ANI7/P27 and ANI8/P150 to ANI14/P156 pins to analog input of A/D converter or digital I/O of port.

The ADPC register can be set by an 8-bit memory manipulation instruction.

Reset signal generation clears this register to 00H.

**Figure 11-15. Format of A/D Port Configuration Register (ADPC)**

Address: F0076H After reset: 00H R/W

Symbol	7	6	5	4	3	2	1	0
ADPC	0	0	0	0	ADPC3	ADPC2	ADPC1	ADPC0

ADPC3	ADPC2	ADPC1	ADPC0	Analog input (A)/digital I/O (D) switching															
				ANI14/P156	ANI13/P155	ANI12/P154	ANI11/P153	ANI10/P152	ANI9/P151	ANI8/P150	ANI7/P27	ANI6/P26	ANI5/P25	ANI4/P24	ANI3/P23	ANI2/P22	ANI1/P21	ANI0/P20	
0	0	0	0	A	A	A	A	A	A	A	A	A	A	A	A	A	A	A	
0	0	0	1	D	D	D	D	D	D	D	D	D	D	D	D	D	D	D	
0	0	1	0	D	D	D	D	D	D	D	D	D	D	D	D	D	D	A	
0	0	1	1	D	D	D	D	D	D	D	D	D	D	D	D	D	A	A	
0	1	0	0	D	D	D	D	D	D	D	D	D	D	D	D	A	A	A	
0	1	0	1	D	D	D	D	D	D	D	D	D	D	D	A	A	A	A	
0	1	1	0	D	D	D	D	D	D	D	D	D	D	A	A	A	A	A	
0	1	1	1	D	D	D	D	D	D	D	D	D	A	A	A	A	A	A	
1	0	0	0	D	D	D	D	D	D	D	D	A	A	A	A	A	A	A	
1	0	0	1	D	D	D	D	D	D	D	D	A	A	A	A	A	A	A	
1	0	1	0	D	D	D	D	D	D	A	A	A	A	A	A	A	A	A	
1	0	1	1	D	D	D	D	D	A	A	A	A	A	A	A	A	A	A	
1	1	0	0	D	D	D	D	A	A	A	A	A	A	A	A	A	A	A	
1	1	0	1	D	D	D	A	A	A	A	A	A	A	A	A	A	A	A	
1	1	1	0	D	D	A	A	A	A	A	A	A	A	A	A	A	A	A	
1	1	1	1	D	A	A	A	A	A	A	A	A	A	A	A	A	A	A	

- Cautions**
1. Set the channel used for A/D conversion to the input mode by using port mode registers 2, 15 (PM2, PM15).
  2. Do not set the pin set by the ADPC register as digital I/O by the analog input channel specification register (ADS).

<R> (12) Port mode control registers 0, 3, 10, 11, 12, 14 (PMC0, PMC3, PMC10, PMC11, PMC12, PMC14)

This register switches the ANI16 to ANI26 pins to digital I/O of port or analog input of A/D converter. These registers can be set by a 1-bit or 8-bit memory manipulation instruction. Reset signal generation clears these registers to FFH.

Figure 11-16. Format of Port Mode Control Register

Symbol	7	6	5	4	3	2	1	0	Address	After reset	R/W
PMC0	1	1	1	1	PMC03 Note 2	PMC02 Note 2	PMC01 Note 1	PMC00 Note 1	F0060H	FFH	R/W
PMC3	PMC37 Note 3	PMC36 Note 3	PMC35 Note 3	1	1	1	1	1	F0063H	FFH	R/W
PMC10	1	1	1	1	1	1	1	PMC100 Note 4	F006AH	FFH	R/W
PMC11	PMC117 Note 3	PMC116 Note 3	PMC115 Note 3	1	1	1	1	1	F006BH	FFH	R/W
PMC12	1	1	1	1	1	1	1	PMC120 Note 5	F006CH	FFH	R/W
PMC14	PMC147 Note 6	1	1	1	1	1	1	1	F006EH	FFH	R/W

PMCmn	Pmn pin digital I/O/analog input selection (m = 0, 3, 10 to 12, 14; n = 0 to 3, 5 to 7)
0	Digital I/O (alternate function other than analog input)
1	Analog input

- Notes**
- 20-, 24-, 25-, 30-, 32-pin products only
  - 52-, 64-, 80-, 100-, 128-pin products only
  - 128-pin products only
  - 80-, 100-, 128-pin products only
  - 30-, 32-, 36-, 40-, 44-, 48-, 52-, 64-, 80-, 100-, 128-pin products only
  - All products



<R> (13) Port mode register 0, 2, 3, 10, 11, 12, 14, 15 (PM0, PM2, PM3, PM10, PM11, PM12, PM14, PM15)

When using the ANI0 to ANI14 or ANI16 to ANI26 pin for an analog input port, set the PMmn bit to 1. The output latches of Pnm at this time may be 0 or 1.

If the PMmn bits are set to 0, they cannot be used as analog input port pins.

The PMmn registers can be set by a 1-bit or 8-bit memory manipulation instruction.

Reset signal generation sets these registers to FFH.

**Caution** If a pin is set as an analog input port, not the pin level but “0” is always read.

**Remark** m = 0, 2, 3, 10, 11, 12, 14, 15, n = 0 to 7

**Figure 11-17. Formats of Port Mode Registers 0, 2, 12, and 14 (PM0, PM2, PM12, PM14) (64-pin products)**

Address: FFF20H After reset: FFH R/W

Symbol	7	6	5	4	3	2	1	0
PM0	PM07	PM06	PM05	PM04	PM03	PM02	PM01	PM00

Address: FFF22H After reset: FFH R/W

Symbol	7	6	5	4	3	2	1	0
PM2	PM27	PM26	PM25	PM24	PM23	PM22	PM21	PM20

Address: FFF2CH After reset: FFH R/W

Symbol	7	6	5	4	3	2	1	0
PM12	1	1	1	1	1	1	1	PM120

Address: FFF2EH After reset: FFH R/W

Symbol	7	6	5	4	3	2	1	0
PM14	1	1	1	1	1	1	PM141	PM140

PMmn	Pmn pin I/O mode selection (mn = 00 to 07, 20 to 27, 120, 140, 141)
0	Output mode (output buffer on)
1	Input mode (output buffer off)

**Remark** For details of the port mode register other than 64-pin products, see 4.3 Registers Controlling Port Function.

<R> The ANI0/P20 to ANI7/P27 and ANI8/P150 to ANI14/P156 pins are as shown below depending on the settings of the A/D port configuration register (ADPC), analog input channel specification register (ADS), PM2 and PM15 registers.

**Table 11-4. Setting Functions of ANI0/P20 to ANI7/P27, ANI8/P150 to ANI14/P156 Pins**

ADPC	PM2, PM15	ADS	ANI0/P20 to ANI7/P27, ANI8/P150 to ANI14/P156 Pins
Digital I/O selection	Input mode	–	Digital input
	Output mode	–	Digital output
Analog input selection	Input mode	Selects ANI.	Analog input (to be converted)
		Does not select ANI.	Analog input (not to be converted)
	Output mode	Selects ANI.	Setting prohibited
		Does not select ANI.	

The ANI16 to ANI26 pins are as shown below depending on the settings of port mode control registers 0, 3, 10, 11, 12, and 14 (PMC0, PMC3, PMC10, PMC11, PMC12, PMC14), analog input channel specification register (ADS), PM0, PM3, PM10, PM11, PM12, and PM14 registers.

**Table 11-5. Setting Functions of ANI16 to ANI26 Pins**

PMC0, PMC3, PMC10, PMC11, PMC12, and PMC14	PM0, PM3, PM10, PM11, PM12, and PM14	ADS	ANI16 to ANI26 Pins
Digital I/O selection	Input mode	–	Digital input
	Output mode	–	Digital output
Analog input selection	Input mode	Selects ANI.	Analog input (to be converted)
		Does not select ANI.	Analog input (not to be converted)
	Output mode	Selects ANI.	Setting prohibited
		Does not select ANI.	

## 11.4 A/D Converter Conversion Operations

The A/D converter conversion operations are described below.

- <1> The voltage input to the selected analog input channel is sampled by the sample & hold circuit.
- <2> When sampling has been done for a certain time, the sample & hold circuit is placed in the hold state and the sampled voltage is held until the A/D conversion operation has ended.
- <3> Bit 9 of the successive approximation register (SAR) is set. The series resistor string voltage tap is set to  $(1/2) AV_{REF}$  by the tap selector.
- <4> The voltage difference between the series resistor string voltage tap and sampled voltage is compared by the voltage comparator. If the analog input is greater than  $(1/2) AV_{REF}$ , the MSB bit of the SAR register remains set to 1. If the analog input is smaller than  $(1/2) AV_{REF}$ , the MSB bit is reset to 0.
- <5> Next, bit 8 of the SAR register is automatically set to 1, and the operation proceeds to the next comparison. The series resistor string voltage tap is selected according to the preset value of bit 9, as described below.
  - Bit 9 = 1:  $(3/4) AV_{REF}$
  - Bit 9 = 0:  $(1/4) AV_{REF}$

The voltage tap and sampled voltage are compared and bit 8 of the SAR register is manipulated as follows.

  - Sampled voltage  $\geq$  Voltage tap: Bit 8 = 1
  - Sampled voltage  $<$  Voltage tap: Bit 8 = 0
- <6> Comparison is continued in this way up to bit 0 of the SAR register.
- <7> Upon completion of the comparison of 10 bits, an effective digital result value remains in the SAR register, and the result value is transferred to the A/D conversion result register (ADCR, ADCRH) and then latched. At the same time, the A/D conversion end interrupt request (INTAD) can also be generated.
- <8> Repeat steps <1> to <7>, until the ADCS bit is cleared to 0<sup>Note</sup>.  
To stop the A/D converter, clear the ADCS bit to 0.

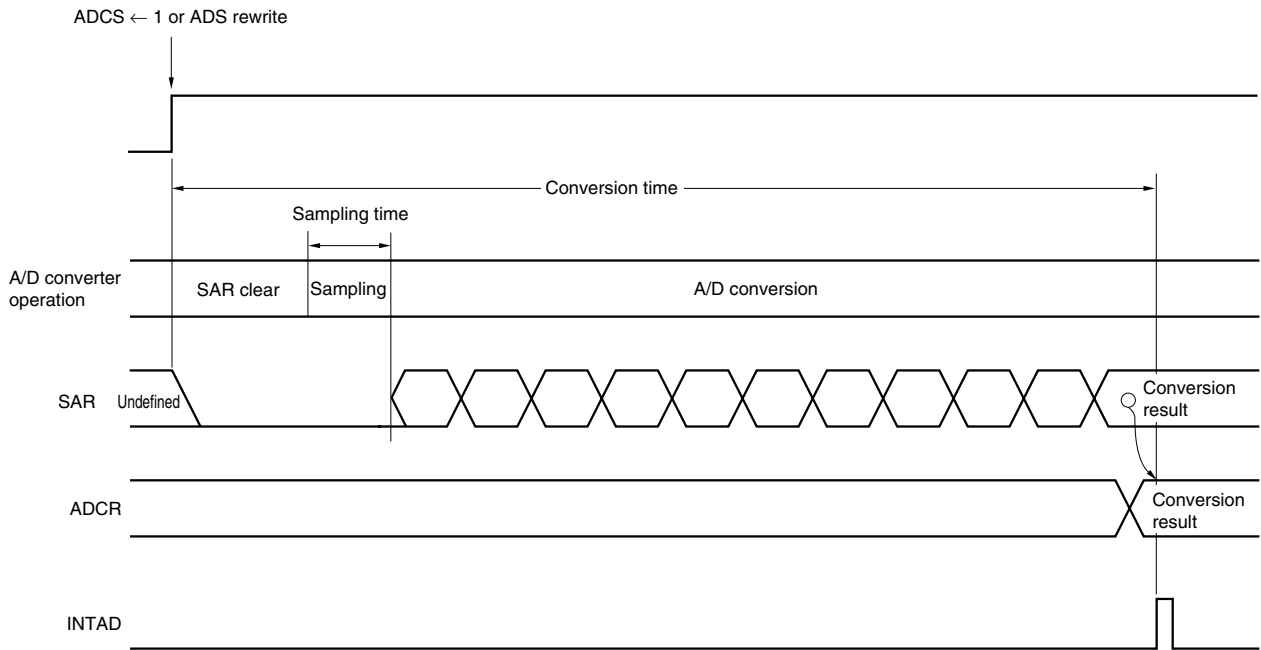
**Note** While in the sequential conversion mode, the ADCS flag is not automatically cleared to 0. This flag is not automatically cleared to 0 while in the one-shot conversion mode of the hardware trigger no-wait mode, either. Instead, 1 is retained.

**Remarks 1.** Two types of the A/D conversion result registers are available.

- ADCR register (16 bits): Store 10-bit A/D conversion value
- ADCRH register (8 bits): Store 8-bit A/D conversion value

**2.**  $AV_{REF}$ : The + side reference voltage of the A/D converter. This can be selected from  $AV_{REFP}$ , the internal reference voltage (1.45 V), and  $V_{DD}$ .

**Figure 11-18. Conversion Operation of A/D Converter (Software Trigger Mode)**



A/D conversion operations are performed continuously until bit 7 (ADCS) of the A/D converter mode register (ADM) is reset (0) by software.

If a write operation is performed to the analog input channel specification register (ADS) during an A/D conversion operation, the conversion operation is initialized, and if the ADCS bit is set (1), conversion starts again from the beginning.

Reset signal generation clears the A/D conversion result register (ADCR, ADCRH) to 0000H or 00H.

### 11.5 Input Voltage and Conversion Results

The relationship between the analog input voltage input to the analog input pins (ANI0 to ANI14, ANI16 to ANI26) and the theoretical A/D conversion result (stored in the 10-bit A/D conversion result register (ADCR)) is shown by the following expression.

$$SAR = \text{INT} \left( \frac{V_{AIN}}{AV_{REF}} \times 1024 + 0.5 \right)$$

$$ADCR = SAR \times 64$$

or

$$\left( \frac{ADCR}{64} - 0.5 \right) \times \frac{AV_{REF}}{1024} \leq V_{AIN} < \left( \frac{ADCR}{64} + 0.5 \right) \times \frac{AV_{REF}}{1024}$$

where, INT( ): Function which returns integer part of value in parentheses

V<sub>AIN</sub>: Analog input voltage

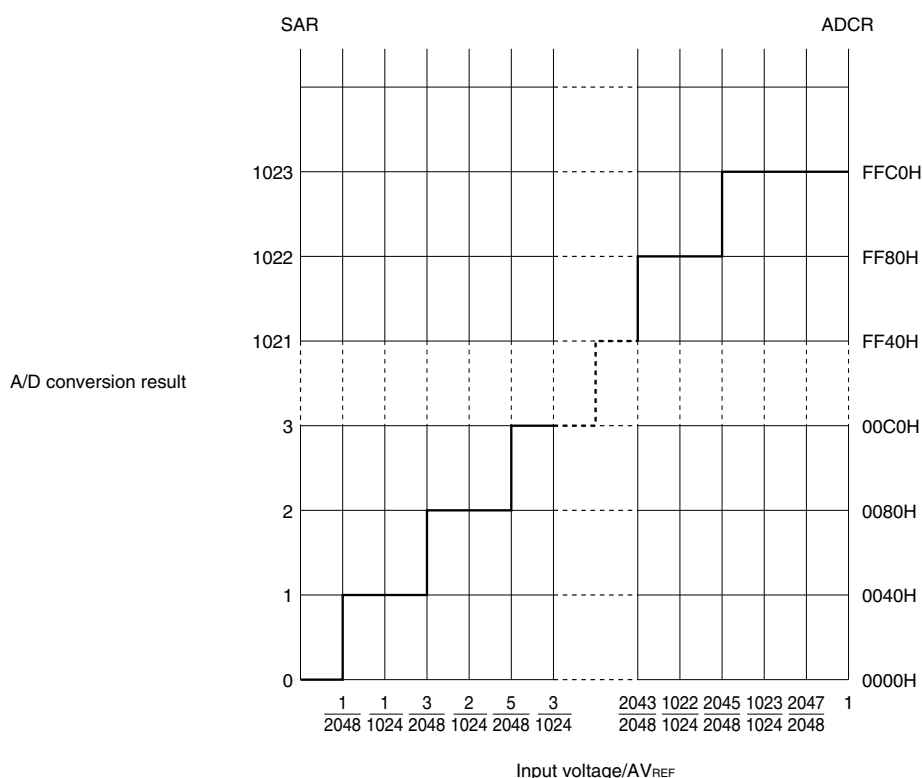
AV<sub>REF</sub>: AV<sub>REF</sub> pin voltage

ADCR: A/D conversion result register (ADCR) value

SAR: Successive approximation register

Figure 11-19 shows the relationship between the analog input voltage and the A/D conversion result.

**Figure 11-19. Relationship Between Analog Input Voltage and A/D Conversion Result**



**Remark** AV<sub>REF</sub>: The + side reference voltage of the A/D converter. This can be selected from AV<sub>REFP</sub>, the internal reference voltage (1.45 V), and V<sub>DD</sub>.

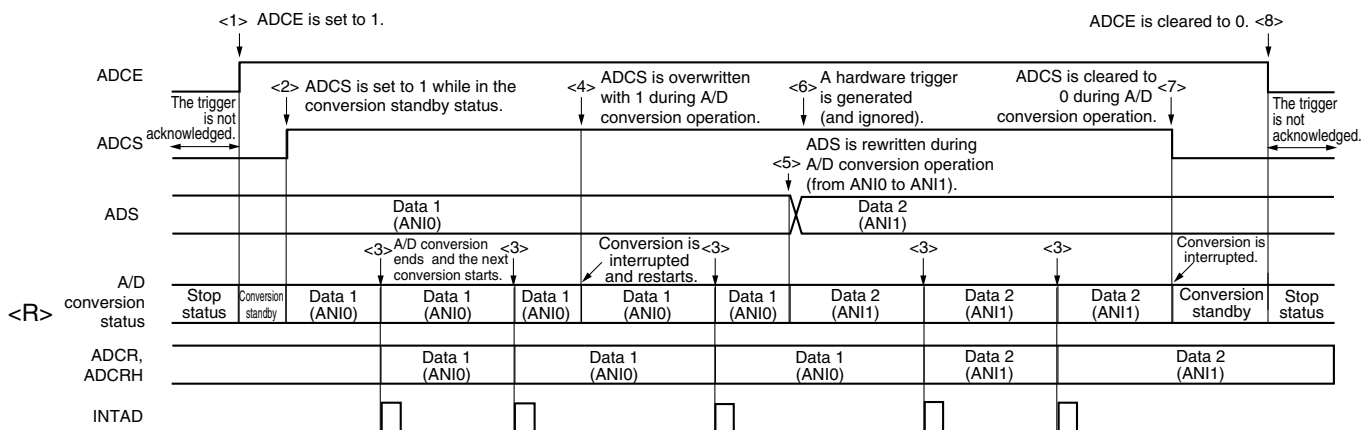
### 11.6 A/D Converter Operation Modes

The operation of each A/D converter mode is described below. In addition, the procedure for specifying each mode is described in 11.7 A/D Converter Setup Flowchart.

#### 11.6.1 Software trigger mode (select mode, sequential conversion mode)

- <R> <1> In the stop status, the ADCE bit of A/D converter mode register 0 (ADM0) is set to 1, and the system enters the A/D conversion standby status.
- <2> After the software counts up to the stabilization wait time (1  $\mu$ S), the ADCS bit of the ADM0 register is set to 1 to perform the A/D conversion of the analog input specified by the analog input channel specification register (ADS).
- <3> When A/D conversion ends, the conversion result is stored in the A/D conversion result register (ADCR, ADCRH), and the A/D conversion end interrupt request signal (INTAD) is generated. After A/D conversion ends, the next A/D conversion immediately starts.
- <4> When ADCS is overwritten with 1 during conversion operation, the current A/D conversion is interrupted, and conversion restarts. The partially converted data is discarded.
- <5> When the value of the ADS register is rewritten or overwritten during conversion operation, the current A/D conversion is interrupted, and A/D conversion is performed on the analog input respecified by the ADS register. The partially converted data is discarded.
- <6> Even if a hardware trigger is input during conversion operation, A/D conversion does not start.
- <7> When ADCS is cleared to 0 during conversion operation, the current A/D conversion is interrupted, and the system enters the A/D conversion standby status.
- <R> <8> When ADCE is cleared to 0 while in the A/D conversion standby status, the A/D converter enters the stop status. When ADCE = 0, specifying 1 for ADCS is ignored and A/D conversion does not start.

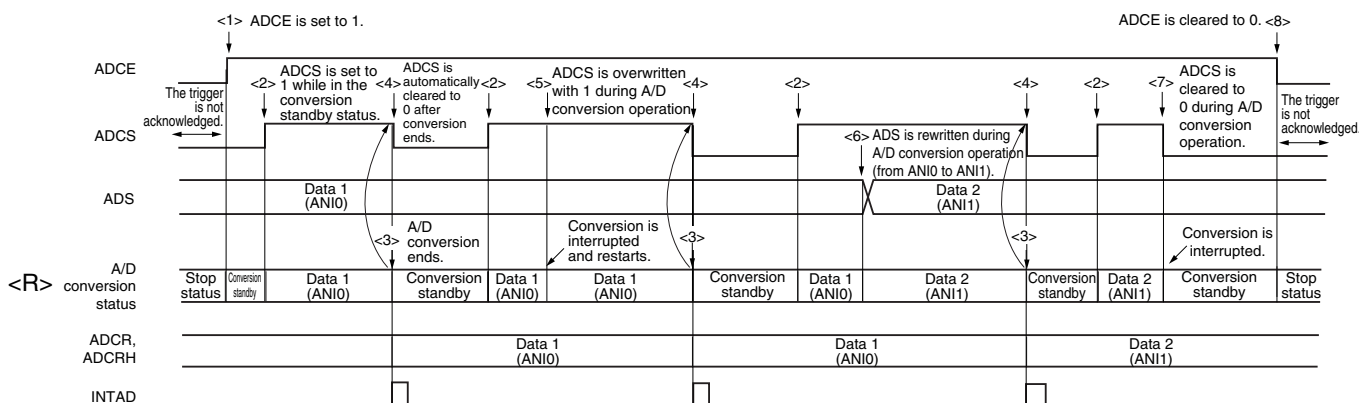
Figure 11-20. Example of Software Trigger Mode (Select Mode, Sequential Conversion Mode) Operation Timing



11.6.2 Software trigger mode (select mode, one-shot conversion mode)

- <R> <1> In the stop status, the ADCE bit of A/D converter mode register 0 (ADM0) is set to 1, and the system enters the A/D conversion standby status.
- <2> After the software counts up to the stabilization wait time (1  $\mu$ s), the ADCS bit of the ADM0 register is set to 1 to perform the A/D conversion of the analog input specified by the analog input channel specification register (ADS).
- <3> When A/D conversion ends, the conversion result is stored in the A/D conversion result register (ADCR, ADCRH), and the A/D conversion end interrupt request signal (INTAD) is generated.
- <4> After A/D conversion ends, the ADCS bit is automatically cleared to 0, and the system enters the A/D conversion standby status.
- <5> When ADCS is overwritten with 1 during conversion operation, the current A/D conversion is interrupted, and conversion restarts. The partially converted data is discarded.
- <6> When the value of the ADS register is rewritten or overwritten during conversion operation, the current A/D conversion is interrupted, and A/D conversion is performed on the analog input respecified by the ADS register. The partially converted data is discarded.
- <7> When ADCS is cleared to 0 during conversion operation, the current A/D conversion is interrupted, and the system enters the A/D conversion standby status.
- <R> <8> When ADCE is cleared to 0 while in the A/D conversion standby status, the A/D converter enters the stop status. When ADCE = 0, specifying 1 for ADCS is ignored and A/D conversion does not start. In addition, A/D conversion does not start even if a hardware trigger is input while in the A/D conversion standby status.

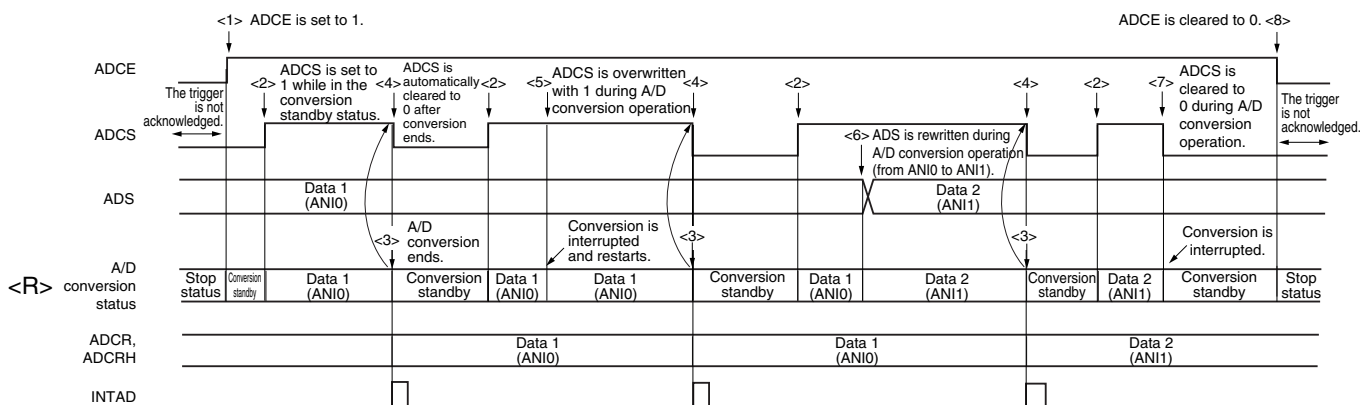
Figure 11-21. Example of Software Trigger Mode (Select Mode, One-Shot Conversion Mode) Operation Timing



11.6.3 Software trigger mode (scan mode, sequential conversion mode)

- <R> <1> In the stop status, the ADCE bit of A/D converter mode register 0 (ADM0) is set to 1, and the system enters the A/D conversion standby status.
- <2> After the software counts up to the stabilization wait time (1  $\mu$ s), the ADCS bit of the ADM0 register is set to 1 to perform A/D conversion on the four analog input channels specified by scan 0 to scan 3, which are specified by the analog input channel specification register (ADS). A/D conversion is performed on the analog input channels in order, starting with that specified by scan 0.
- <3> A/D conversion is sequentially performed on the four analog input channels, the conversion results are stored in the A/D conversion result register (ADCR, ADCRH) each time conversion ends, and the A/D conversion end interrupt request signal (INTAD) is generated. After A/D conversion of the four channels ends, the A/D conversion of the channel following the specified channel automatically starts (until all four channels are finished).
- <4> When ADCS is overwritten with 1 during conversion operation, the current A/D conversion is interrupted, and conversion restarts at the first channel. The partially converted data is discarded.
- <5> When the value of the ADS register is rewritten or overwritten during conversion operation, the current A/D conversion is interrupted, and A/D conversion is performed on the first channel respecified by the ADS register. The partially converted data is discarded.
- <6> Even if a hardware trigger is input during conversion operation, A/D conversion does not start.
- <7> When ADCS is cleared to 0 during conversion operation, the current A/D conversion is interrupted, and the system enters the A/D conversion standby status.
- <R> <8> When ADCE is cleared to 0 while in the A/D conversion standby status, the A/D converter enters the stop status. When ADCE = 0, specifying 1 for ADCS is ignored and A/D conversion does not start.

Figure 11-22. Example of Software Trigger Mode (Scan Mode, Sequential Conversion Mode) Operation Timing

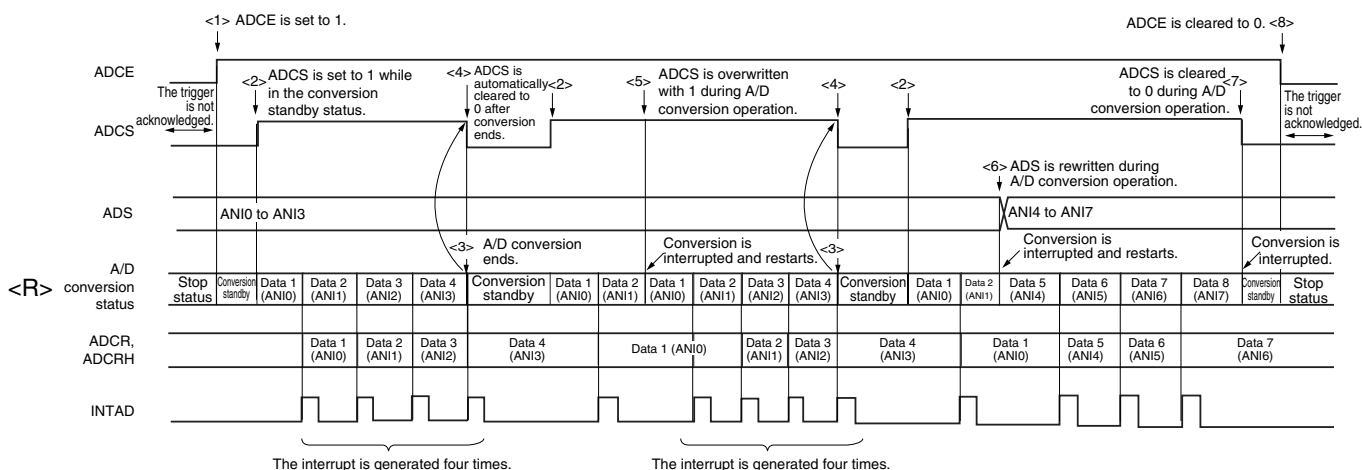




11.6.4 Software trigger mode (scan mode, one-shot conversion mode)

- <R> <1> In the stop status, the ADCE bit of A/D converter mode register 0 (ADM0) is set to 1, and the system enters the A/D conversion standby status.
- <2> After the software counts up to the stabilization wait time (1  $\mu$ s), the ADCS bit of the ADM0 register is set to 1 to perform A/D conversion on the four analog input channels specified by scan 0 to scan 3, which are specified by the analog input channel specification register (ADS). A/D conversion is performed on the analog input channels in order, starting with that specified by scan 0.
- <3> A/D conversion is sequentially performed on the four analog input channels, the conversion results are stored in the A/D conversion result register (ADCR, ADCRH) each time conversion ends, and the A/D conversion end interrupt request signal (INTAD) is generated.
- <4> After A/D conversion of the four channels ends, the ADCS bit is automatically cleared to 0, and the system enters the A/D conversion standby status.
- <5> When ADCS is overwritten with 1 during conversion operation, the current A/D conversion is interrupted, and conversion restarts at the first channel. The partially converted data is discarded.
- <6> When the value of the ADS register is rewritten or overwritten during conversion operation, the current A/D conversion is interrupted, and A/D conversion is performed on the first channel respecified by the ADS register. The partially converted data is discarded.
- <7> When ADCS is cleared to 0 during conversion operation, the current A/D conversion is interrupted, and the system enters the A/D conversion standby status.
- <R> <8> When ADCE is cleared to 0 while in the A/D conversion standby status, the A/D converter enters the stop status. When ADCE = 0, specifying 1 for ADCS is ignored and A/D conversion does not start. In addition, A/D conversion does not start even if a hardware trigger is input while in the A/D conversion standby status.

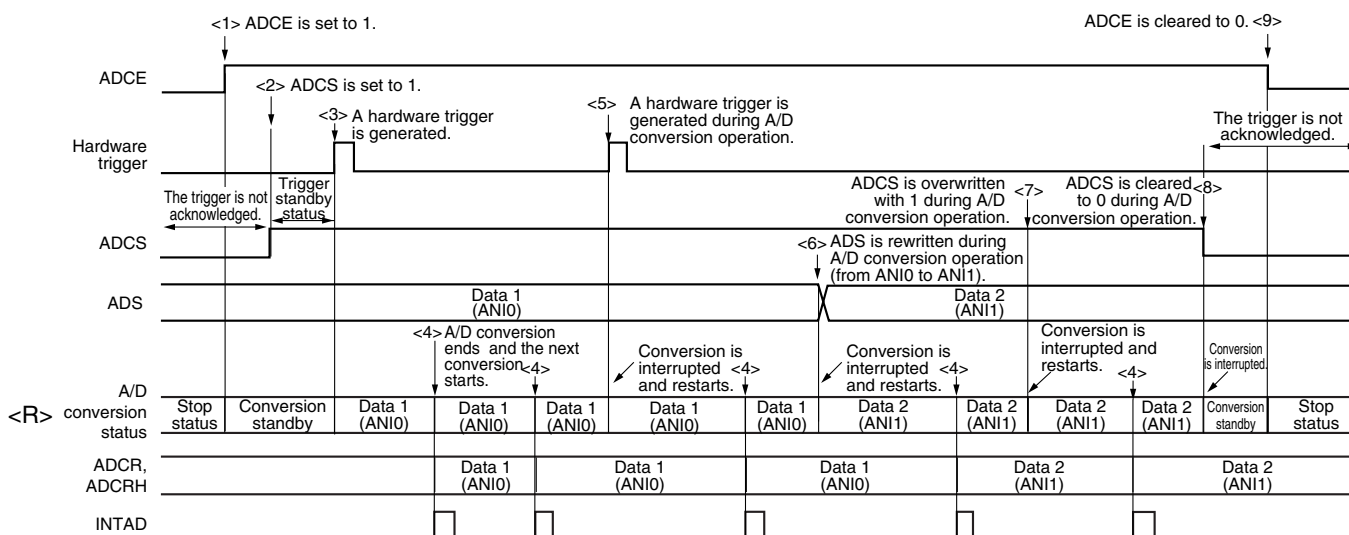
Figure 11-23. Example of Software Trigger Mode (Scan Mode, One-Shot Conversion Mode) Operation Timing



11.6.5 Hardware trigger no-wait mode (select mode, sequential conversion mode)

- <R> <1> In the stop status, the ADCE bit of A/D converter mode register 0 (ADM0) is set to 1, and the system enters the A/D conversion standby status.
- <2> After the software counts up to the stabilization wait time (1  $\mu$ s), the ADCS bit of the ADM0 register is set to 1 to place the system in the hardware trigger standby status (and conversion does not start at this stage). Note that, while in this status, A/D conversion does not start even if ADCS is set to 1.
- <3> If a hardware trigger is input while ADCS = 1, A/D conversion is performed on the analog input specified by the analog input channel specification register (ADS).
- <4> When A/D conversion ends, the conversion result is stored in the A/D conversion result register (ADCR, ADCRH), and the A/D conversion end interrupt request signal (INTAD) is generated. After A/D conversion ends, the next A/D conversion immediately starts.
- <5> If a hardware trigger is input during conversion operation, the current A/D conversion is interrupted, and conversion restarts. The partially converted data is discarded.
- <6> When the value of the ADS register is rewritten or overwritten during conversion operation, the current A/D conversion is interrupted, and A/D conversion is performed on the analog input respecified by the ADS register. The partially converted data is discarded.
- <7> When ADCS is overwritten with 1 during conversion operation, the current A/D conversion is interrupted, and conversion restarts. The partially converted data is discarded.
- <8> When ADCS is cleared to 0 during conversion operation, the current A/D conversion is interrupted, and the system enters the A/D conversion standby status. However, the A/D converter does not stop in this status.
- <R> <9> When ADCE is cleared to 0 while in the A/D conversion standby status, the A/D converter enters the stop status. When ADCS = 0, inputting a hardware trigger is ignored and A/D conversion does not start.

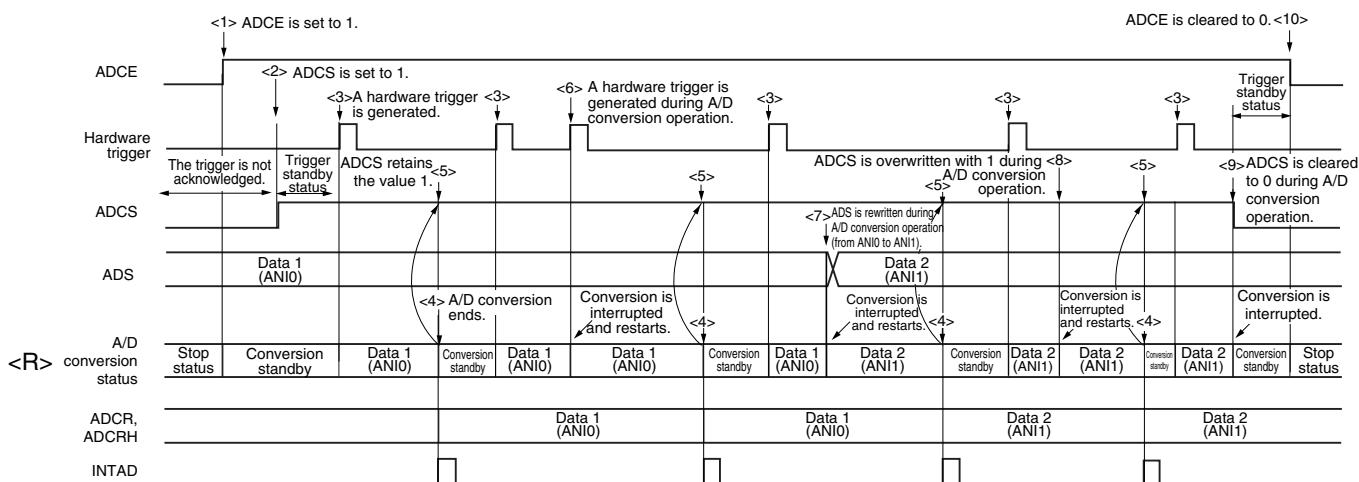
Figure 11-24. Example of Hardware Trigger No-Wait Mode (Select Mode, Sequential Conversion Mode) Operation Timing



11.6.6 Hardware trigger no-wait mode (select mode, one-shot conversion mode)

- <R> <1> In the stop status, the ADCE bit of A/D converter mode register 0 (ADM0) is set to 1, and the system enters the A/D conversion standby status.
- <2> After the software counts up to the stabilization wait time (1  $\mu$ s), the ADCS bit of the ADM0 register is set to 1 to place the system in the hardware trigger standby status (and conversion does not start at this stage). Note that, while in this status, A/D conversion does not start even if ADCS is set to 1.
- <3> If a hardware trigger is input while ADCS = 1, A/D conversion is performed on the analog input specified by the analog input channel specification register (ADS).
- <4> When A/D conversion ends, the conversion result is stored in the A/D conversion result register (ADCR, ADCRH), and the A/D conversion end interrupt request signal (INTAD) is generated.
- <5> After A/D conversion ends, the ADCS bit remains set to 1, and the system enters the A/D conversion standby status.
- <6> If a hardware trigger is input during conversion operation, the current A/D conversion is interrupted, and conversion restarts. The partially converted data is discarded.
- <7> When the value of the ADS register is rewritten or overwritten during conversion operation, the current A/D conversion is interrupted, and A/D conversion is performed on the analog input respecified by the ADS register. The partially converted data is discarded.
- <8> When ADCS is overwritten with 1 during conversion operation, the current A/D conversion is interrupted, and conversion restarts. The partially converted data is discarded.
- <9> When ADCS is cleared to 0 during conversion operation, the current A/D conversion is interrupted, and the system enters the A/D conversion standby status. However, the A/D converter does not stop in this status.
- <R> <10> When ADCE is cleared to 0 while in the A/D conversion standby status, the A/D converter enters the stop status. When ADCS = 0, inputting a hardware trigger is ignored and A/D conversion does not start.

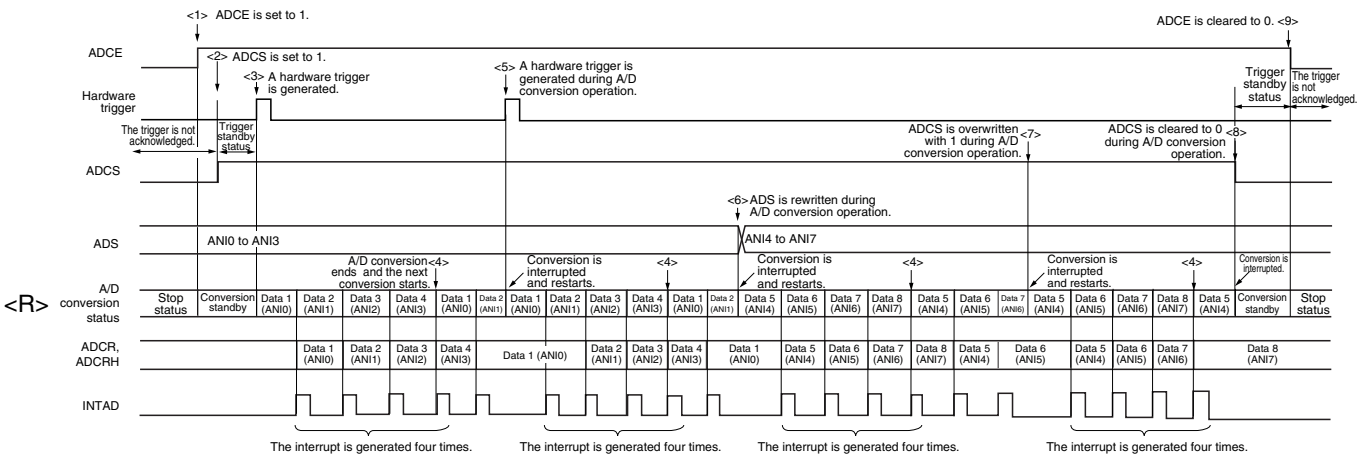
Figure 11-25. Example of Hardware Trigger No-Wait Mode (Select Mode, One-Shot Conversion Mode) Operation Timing



11.6.7 Hardware trigger no-wait mode (scan mode, sequential conversion mode)

- <R> <1> In the stop status, the ADCE bit of A/D converter mode register 0 (ADM0) is set to 1, and the system enters the A/D conversion standby status.
- <2> After the software counts up to the stabilization wait time (1  $\mu$ s), the ADCS bit of the ADM0 register is set to 1 to place the system in the hardware trigger standby status (and conversion does not start at this stage). Note that, while in this status, A/D conversion does not start even if ADCS is set to 1.
- <3> If a hardware trigger is input while ADCS = 1, A/D conversion is performed on the four analog input channels specified by scan 0 to scan 3, which are specified by the analog input channel specification register (ADS). A/D conversion is performed on the analog input channels in order, starting with that specified by scan 0.
- <4> A/D conversion is sequentially performed on the four analog input channels, the conversion results are stored in the A/D conversion result register (ADCR, ADCRH) each time conversion ends, and the A/D conversion end interrupt request signal (INTAD) is generated. After A/D conversion of the four channels ends, the A/D conversion of the channel following the specified channel automatically starts.
- <5> If a hardware trigger is input during conversion operation, the current A/D conversion is interrupted, and conversion restarts at the first channel. The partially converted data is discarded.
- <6> When the value of the ADS register is rewritten or overwritten during conversion operation, the current A/D conversion is interrupted, and A/D conversion is performed on the first channel respecified by the ADS register. The partially converted data is discarded.
- <7> When ADCS is overwritten with 1 during conversion operation, the current A/D conversion is interrupted, and conversion restarts. The partially converted data is discarded.
- <8> When ADCS is cleared to 0 during conversion operation, the current A/D conversion is interrupted, and the system enters the A/D conversion standby status. However, the A/D converter does not stop in this status.
- <R> <9> When ADCE is cleared to 0 while in the A/D conversion standby status, the A/D converter enters the stop status. When ADCE = 0, specifying 1 for ADCS is ignored and A/D conversion does not start.

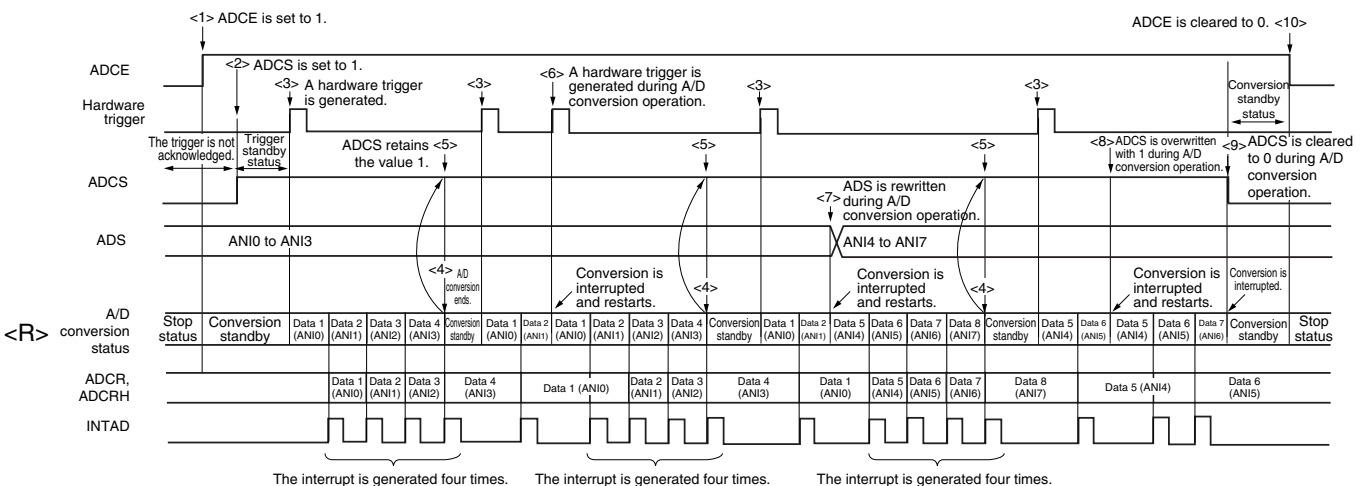
Figure 11-26. Example of Hardware Trigger No-Wait Mode (Scan Mode, Sequential Conversion Mode) Operation Timing



11.6.8 Hardware trigger no-wait mode (scan mode, one-shot conversion mode)

- <R> <1> In the stop status, the ADCE bit of A/D converter mode register 0 (ADM0) is set to 1, and the system enters the A/D conversion standby status.
- <2> After the software counts up to the stabilization wait time (1  $\mu$ s), the ADCS bit of the ADM0 register is set to 1 to place the system in the hardware trigger standby status (and conversion does not start at this stage). Note that, while in this status, A/D conversion does not start even if ADCS is set to 1.
- <3> If a hardware trigger is input while ADCS = 1, A/D conversion is performed on the four analog input channels specified by scan 0 to scan 3, which are specified by the analog input channel specification register (ADS). A/D conversion is performed on the analog input channels in order, starting with that specified by scan 0.
- <4> A/D conversion is sequentially performed on the four analog input channels, the conversion results are stored in the A/D conversion result register (ADCR, ADCRH) each time conversion ends, and the A/D conversion end interrupt request signal (INTAD) is generated.
- <5> After A/D conversion of the four channels ends, the ADCS bit remains set to 1, and the system enters the A/D conversion standby status.
- <6> If a hardware trigger is input during conversion operation, the current A/D conversion is interrupted, and conversion restarts at the first channel. The partially converted data is discarded.
- <7> When the value of the ADS register is rewritten or overwritten during conversion operation, the current A/D conversion is interrupted, and A/D conversion is performed on the first channel respecified by the ADS register. The partially converted data is discarded.
- <8> When ADCS is overwritten with 1 during conversion operation, the current A/D conversion is interrupted, and conversion restarts at the first channel. The partially converted data is discarded.
- <9> When ADCS is cleared to 0 during conversion operation, the current A/D conversion is interrupted, and the system enters the A/D conversion standby status. However, the A/D converter does not stop in this status.
- <R> <R> <10> When ADCE is cleared to 0 while in the A/D conversion standby status, the A/D converter enters the stop status. When ADCS = 0, inputting a hardware trigger is ignored and A/D conversion does not start.

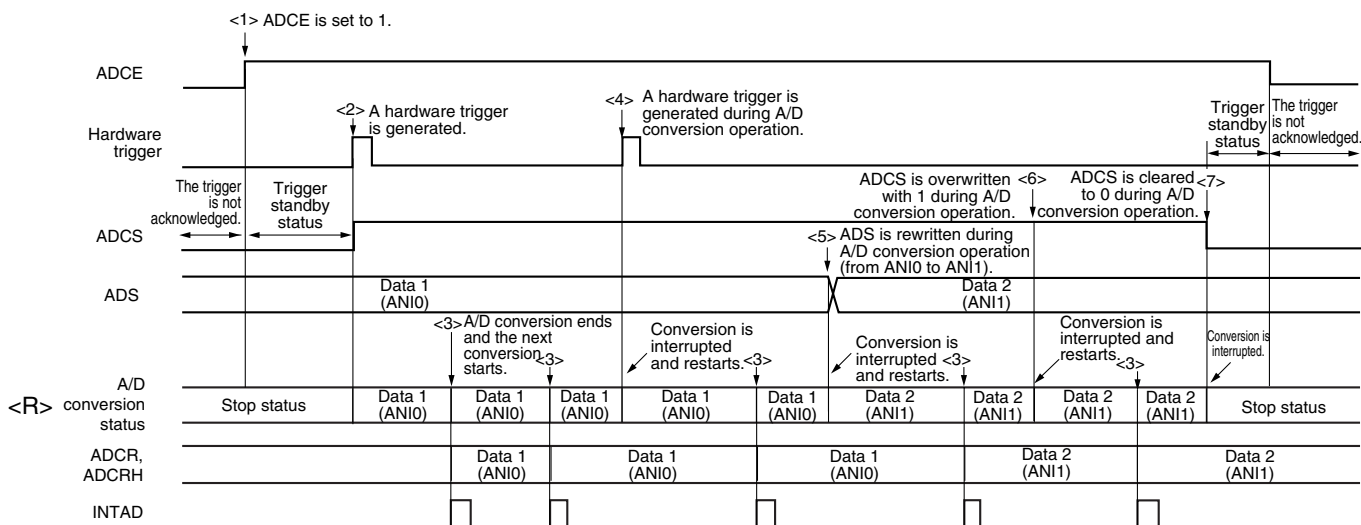
Figure 11-27. Example of Hardware Trigger No-Wait Mode (Scan Mode, One-Shot Conversion Mode) Operation Timing



11.6.9 Hardware trigger wait mode (select mode, sequential conversion mode)

- <R> <1> In the stop status, the ADCE bit of A/D converter mode register 0 (ADM0) is set to 1, and the system enters the hardware trigger standby status.
- <2> If a hardware trigger is input while in the hardware trigger standby status, A/D conversion is performed on the analog input specified by the analog input channel specification register (ADS). The ADCS bit of the ADM0 register is automatically set to 1 according to the hardware trigger input.
- <3> When A/D conversion ends, the conversion result is stored in the A/D conversion result register (ADCR, ADCRH), and the A/D conversion end interrupt request signal (INTAD) is generated. After A/D conversion ends, the next A/D conversion immediately starts. (At this time, no hardware trigger is necessary.)
- <4> If a hardware trigger is input during conversion operation, the current A/D conversion is interrupted, and conversion restarts. The partially converted data is discarded.
- <5> When the value of the ADS register is rewritten or overwritten during conversion operation, the current A/D conversion is interrupted, and A/D conversion is performed on the analog input respecified by the ADS register. The partially converted data is discarded.
- <6> When ADCS is overwritten with 1 during conversion operation, the current A/D conversion is interrupted, and conversion restarts. The partially converted data is discarded.
- <7> When ADCS is cleared to 0 during conversion operation, the current A/D conversion is interrupted, the system enters the hardware trigger standby status, and the A/D converter enters the stop status. When ADCE = 0, inputting a hardware trigger is ignored and A/D conversion does not start.

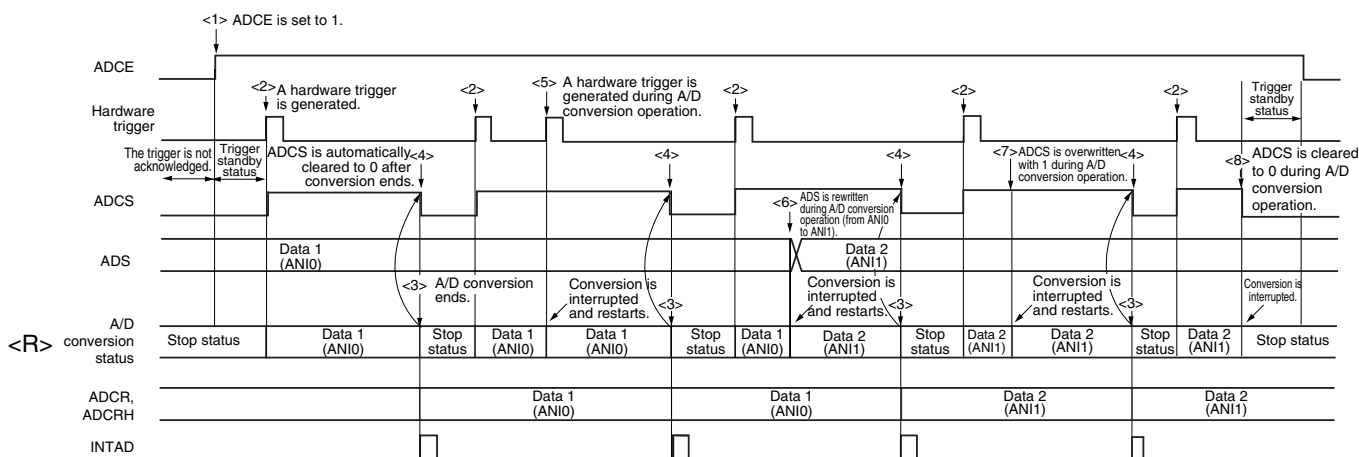
Figure 11-28. Example of Hardware Trigger Wait Mode (Select Mode, Sequential Conversion Mode) Operation Timing



11.6.10 Hardware trigger wait mode (select mode, one-shot conversion mode)

- <R> <1> In the stop status, the ADCE bit of A/D converter mode register 0 (ADM0) is set to 1, and the system enters the hardware trigger standby status.
- <2> If a hardware trigger is input while in the hardware trigger standby status, A/D conversion is performed on the analog input specified by the analog input channel specification register (ADS). The ADCS bit of the ADM0 register is automatically set to 1 according to the hardware trigger input.
- <3> When A/D conversion ends, the conversion result is stored in the A/D conversion result register (ADCR, ADCRH), and the A/D conversion end interrupt request signal (INTAD) is generated.
- <4> After A/D conversion ends, the ADCS bit is automatically cleared to 0, and the A/D converter enters the stop status.
- <5> If a hardware trigger is input during conversion operation, the current A/D conversion is interrupted, and conversion restarts. The partially converted data is discarded.
- <6> When the value of the ADS register is rewritten or overwritten during conversion operation, the current A/D conversion is interrupted, and A/D conversion is performed on the analog input respecified by the ADS register. The partially converted data is discarded.
- <7> When ADCS is overwritten with 1 during conversion operation, the current A/D conversion is interrupted, and conversion restarts. The partially converted data is initialized.
- <8> When ADCS is cleared to 0 during conversion operation, the current A/D conversion is interrupted, the system enters the hardware trigger standby status, and the A/D converter enters the stop status. When ADCE = 0, inputting a hardware trigger is ignored and A/D conversion does not start.

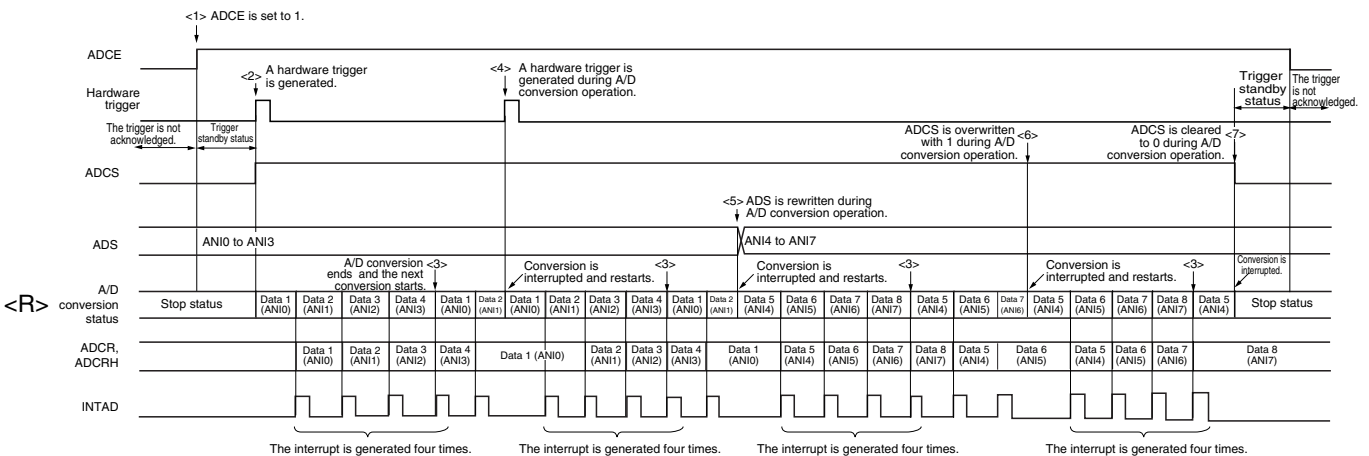
Figure 11-29. Example of Hardware Trigger Wait Mode (Select Mode, One-Shot Conversion Mode) Operation Timing



11.6.11 Hardware trigger wait mode (scan mode, sequential conversion mode)

- <R> <1> In the stop status, the ADCE bit of A/D converter mode register 0 (ADM0) is set to 1, and the system enters the A/D conversion standby status.
- <2> If a hardware trigger is input while in the hardware trigger standby status, A/D conversion is performed on the four analog input channels specified by scan 0 to scan 3, which are specified by the analog input channel specification register (ADS). The ADCS bit of the ADM0 register is automatically set to 1 according to the hardware trigger input. A/D conversion is performed on the analog input channels in order, starting with that specified by scan 0.
- <3> A/D conversion is sequentially performed on the four analog input channels, the conversion results are stored in the A/D conversion result register (ADCR, ADCRH) each time conversion ends, and the A/D conversion end interrupt request signal (INTAD) is generated. After A/D conversion of the four channels ends, the A/D conversion of the channel following the specified channel automatically starts.
- <4> If a hardware trigger is input during conversion operation, the current A/D conversion is interrupted, and conversion restarts at the first channel. The partially converted data is discarded.
- <5> When the value of the ADS register is rewritten or overwritten during conversion operation, the current A/D conversion is interrupted, and A/D conversion is performed on the first channel respecified by the ADS register. The partially converted data is discarded.
- <6> When ADCS is overwritten with 1 during conversion operation, the current A/D conversion is interrupted, and conversion restarts. The partially converted data is discarded.
- <7> When ADCS is cleared to 0 during conversion operation, the current A/D conversion is interrupted, the system enters the hardware trigger standby status, and the A/D converter enters the stop status. When ADCE = 0, inputting a hardware trigger is ignored and A/D conversion does not start.

Figure 11-30. Example of Hardware Trigger Wait Mode (Scan Mode, Sequential Conversion Mode) Operation Timing

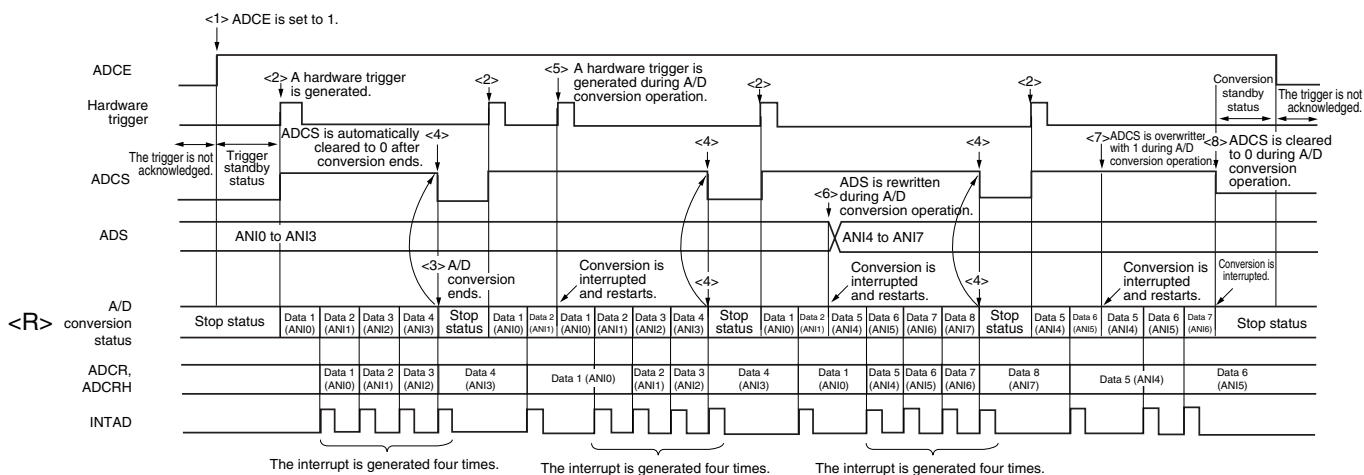




11.6.12 Hardware trigger wait mode (scan mode, one-shot conversion mode)

- <R> <1> In the stop status, the ADCE bit of A/D converter mode register 0 (ADM0) is set to 1, and the system enters the A/D conversion standby status.
- <2> If a hardware trigger is input while in the hardware trigger standby status, A/D conversion is performed on the four analog input channels specified by scan 0 to scan 3, which are specified by the analog input channel specification register (ADS). The ADCS bit of the ADM0 register is automatically set to 1 according to the hardware trigger input. A/D conversion is performed on the analog input channels in order, starting with that specified by scan 0.
- <3> A/D conversion is sequentially performed on the four analog input channels, the conversion results are stored in the A/D conversion result register (ADCR, ADCRH) each time conversion ends, and the A/D conversion end interrupt request signal (INTAD) is generated.
- <4> After A/D conversion ends, the ADCS bit is automatically cleared to 0, and the A/D converter enters the stop status.
- <5> If a hardware trigger is input during conversion operation, the current A/D conversion is interrupted, and conversion restarts at the first channel. The partially converted data is discarded.
- <6> When the value of the ADS register is rewritten or overwritten during conversion operation, the current A/D conversion is interrupted, and A/D conversion is performed on the first channel respecified by the ADS register. The partially converted data is discarded.
- <7> When ADCS is overwritten with 1 during conversion operation, the current A/D conversion is interrupted, and conversion restarts. The partially converted data is discarded.
- <8> When ADCS is cleared to 0 during conversion operation, the current A/D conversion is interrupted, the system enters the hardware trigger standby status, and the A/D converter enters the stop status. When ADCE = 0, inputting a hardware trigger is ignored and A/D conversion does not start.

Figure 11-31. Example of Hardware Trigger Wait Mode (Scan Mode, One-Shot Conversion Mode) Operation Timing

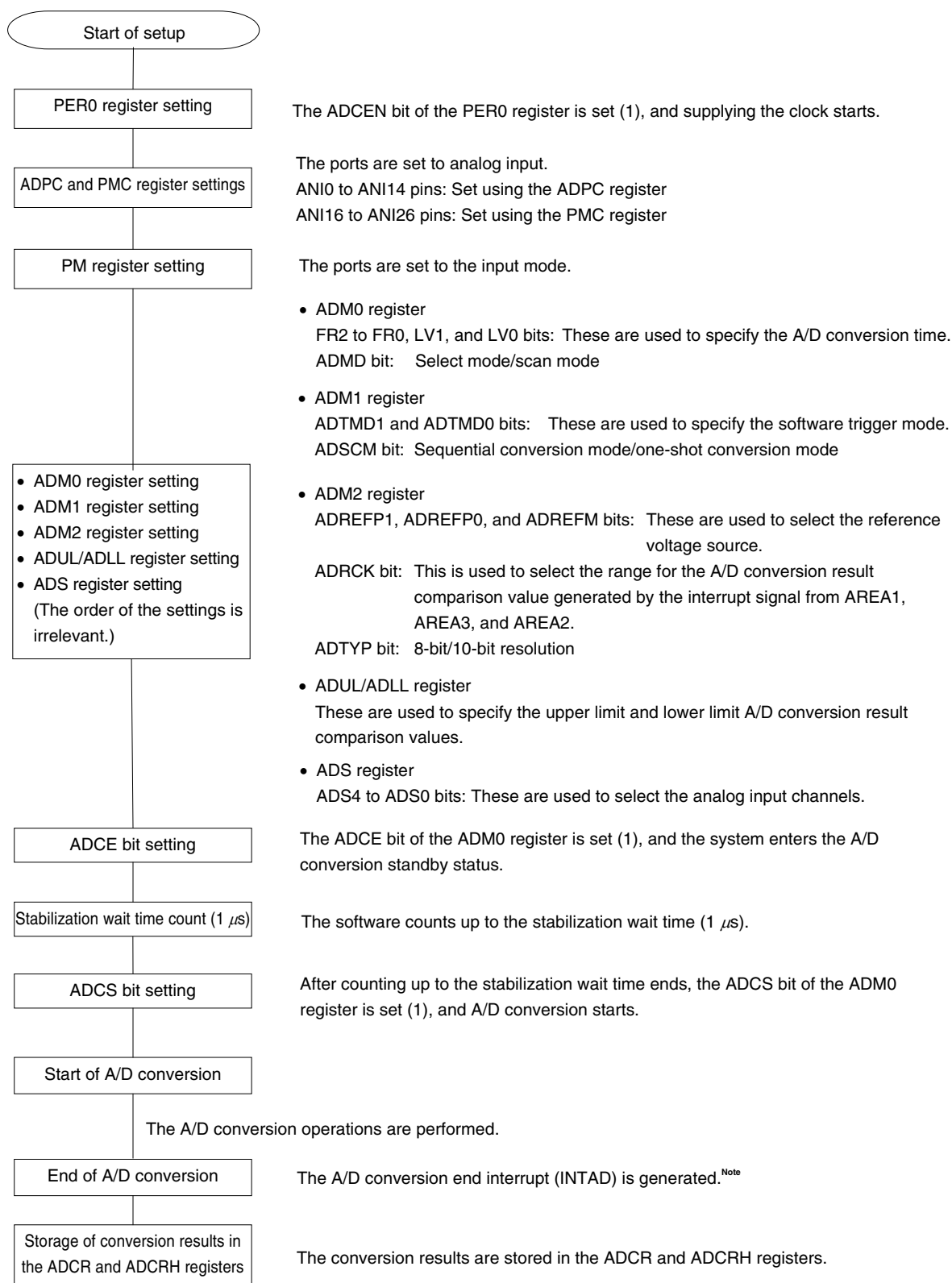


## 11.7 A/D Converter Setup Flowchart

The A/D converter setup flowchart in each operation mode is described below.

11.7.1 Setting up software trigger mode

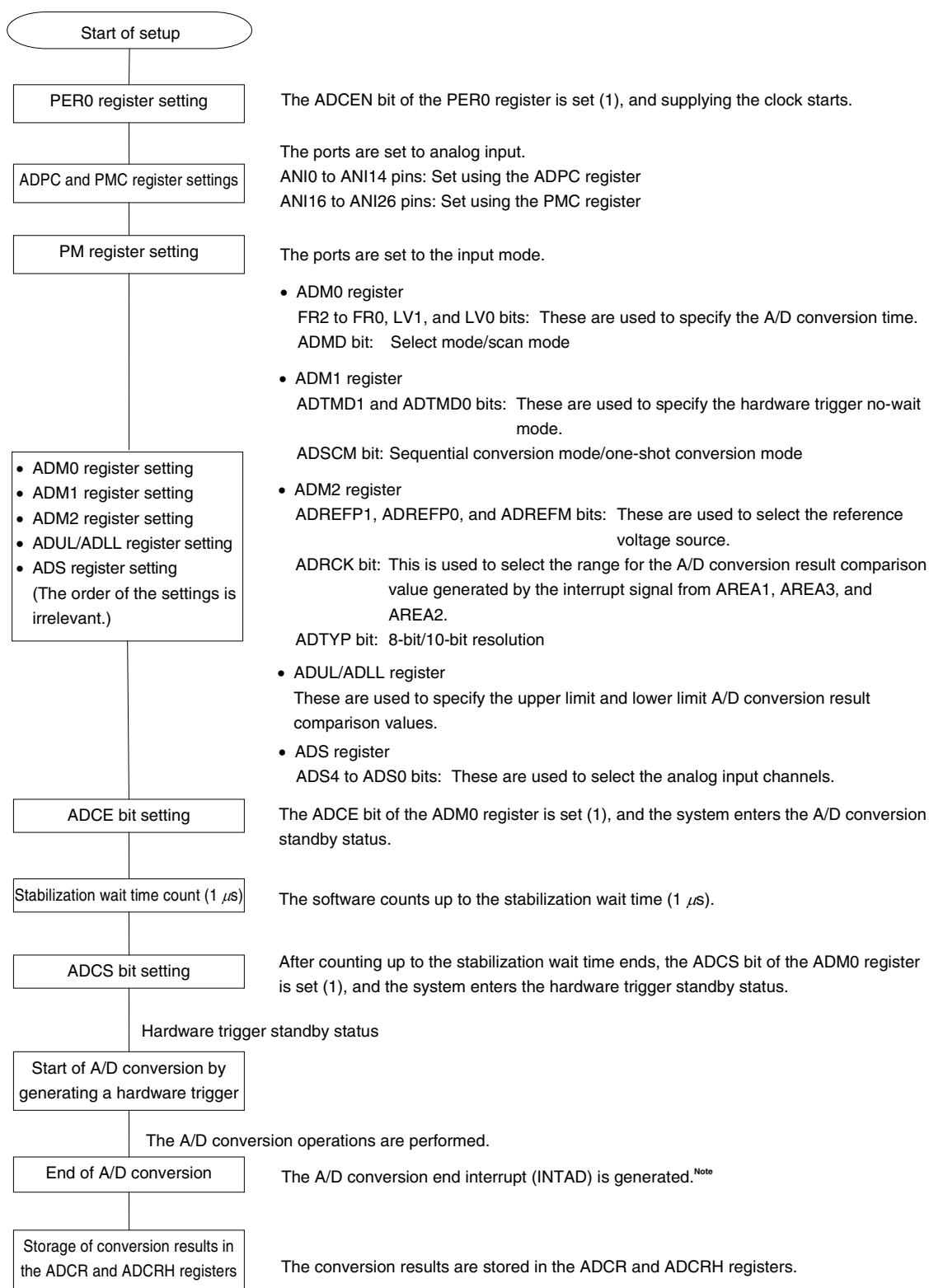
Figure 11-32. Setting up Software Trigger Mode



**Note** Depending on the settings of the ADRCK bit and ADUL/ADLL register, there is a possibility of no interrupt signal being generated. In this case, the results are not stored in the ADCR, ADCRH registers.

11.7.2 Setting up hardware trigger no-wait mode

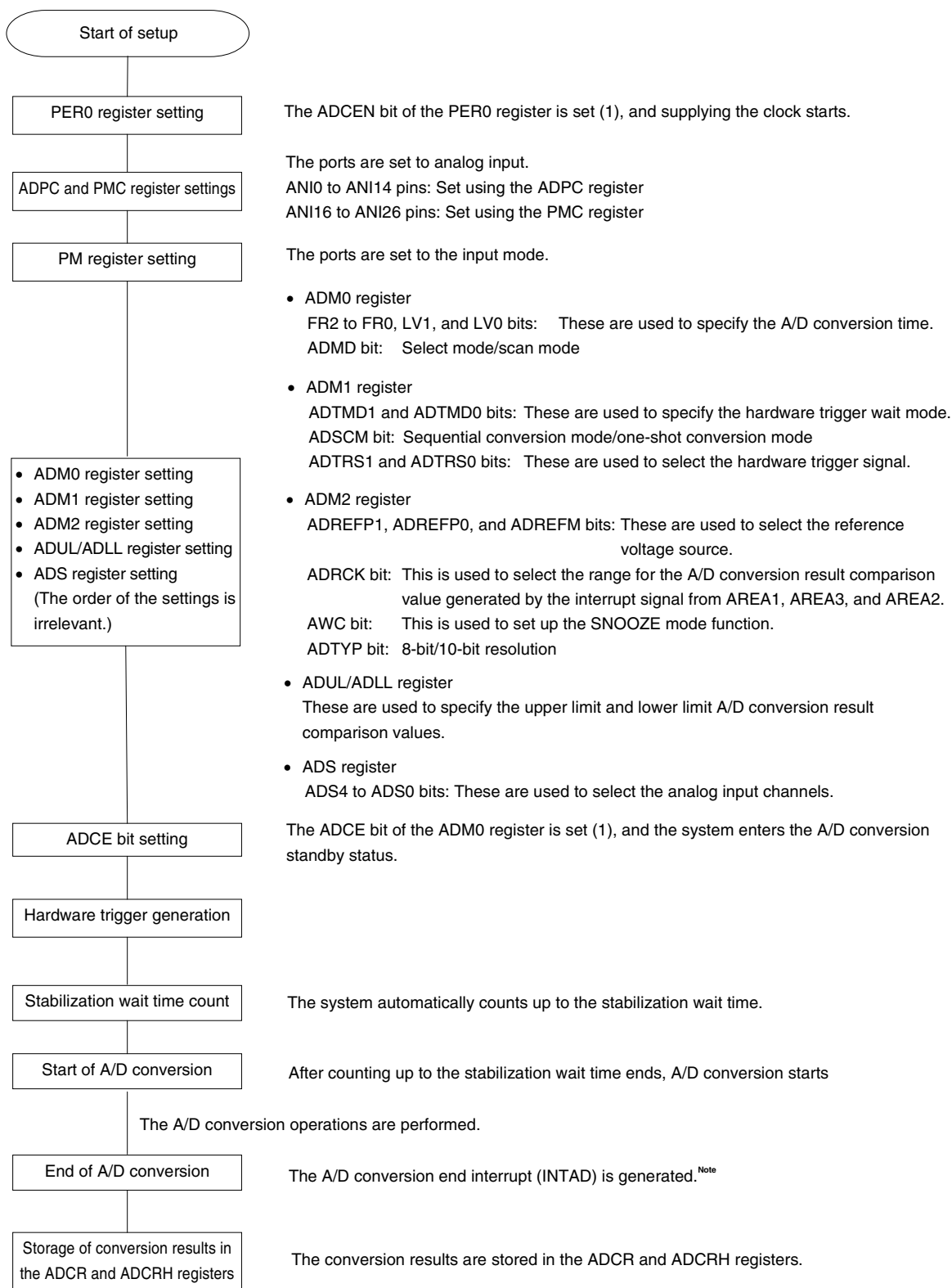
Figure 11-33. Setting up Hardware Trigger No-Wait Mode



**Note** Depending on the settings of the ADRCK bit and ADUL/ADLL register, there is a possibility of no interrupt signal being generated. In this case, the results are not stored in the ADCR, ADCRH registers.

11.7.3 Setting up hardware trigger wait mode

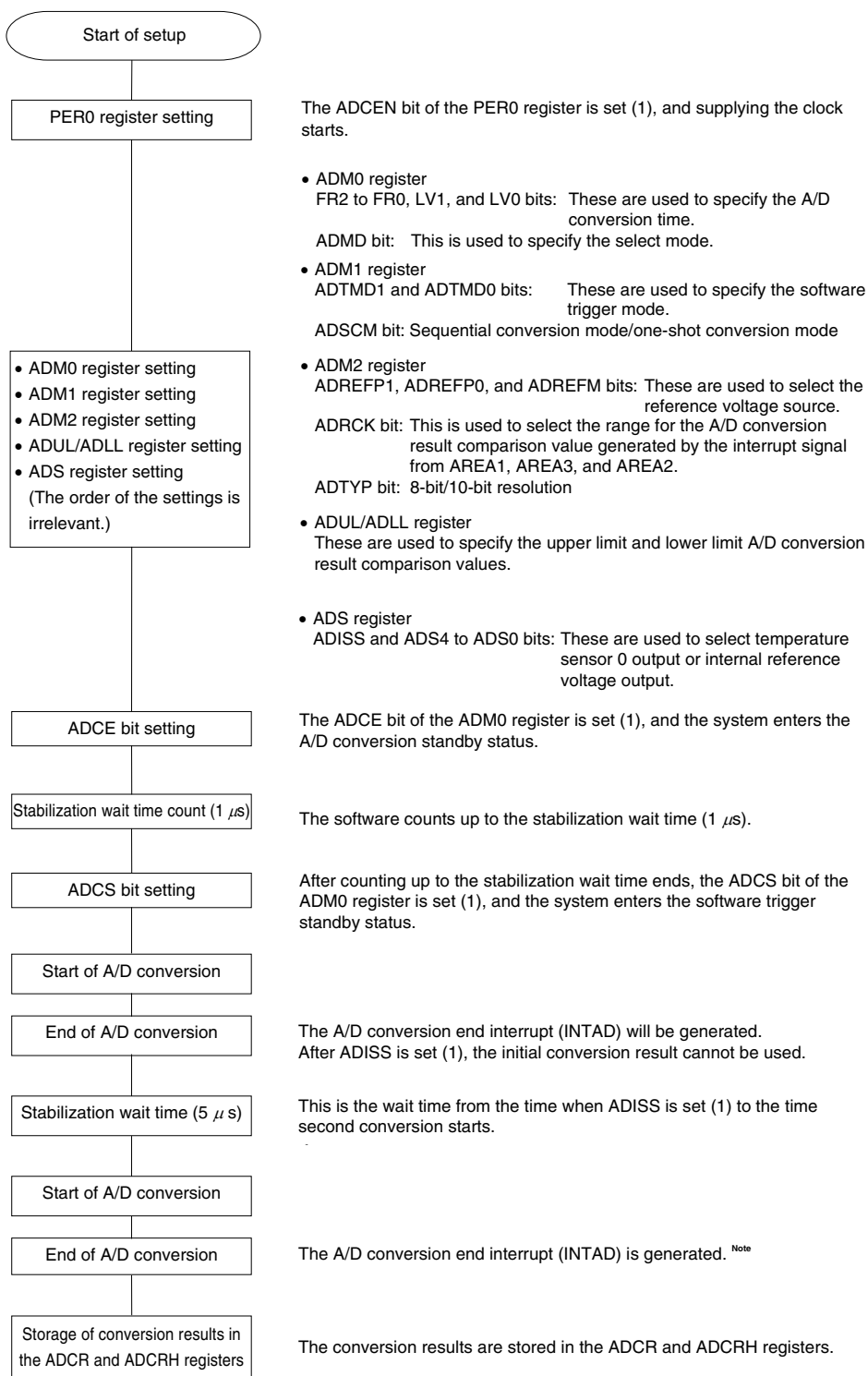
Figure 11-34. Setting up Hardware Trigger Wait Mode



**Note** Depending on the settings of the ADRCK bit and ADUL/ADLL register, there is a possibility of no interrupt signal being generated. In this case, the results are not stored in the ADCR, ADCRH registers.

<R> 11.7.4 Setup when using temperature sensor (example for software trigger mode and one-shot conversion mode)

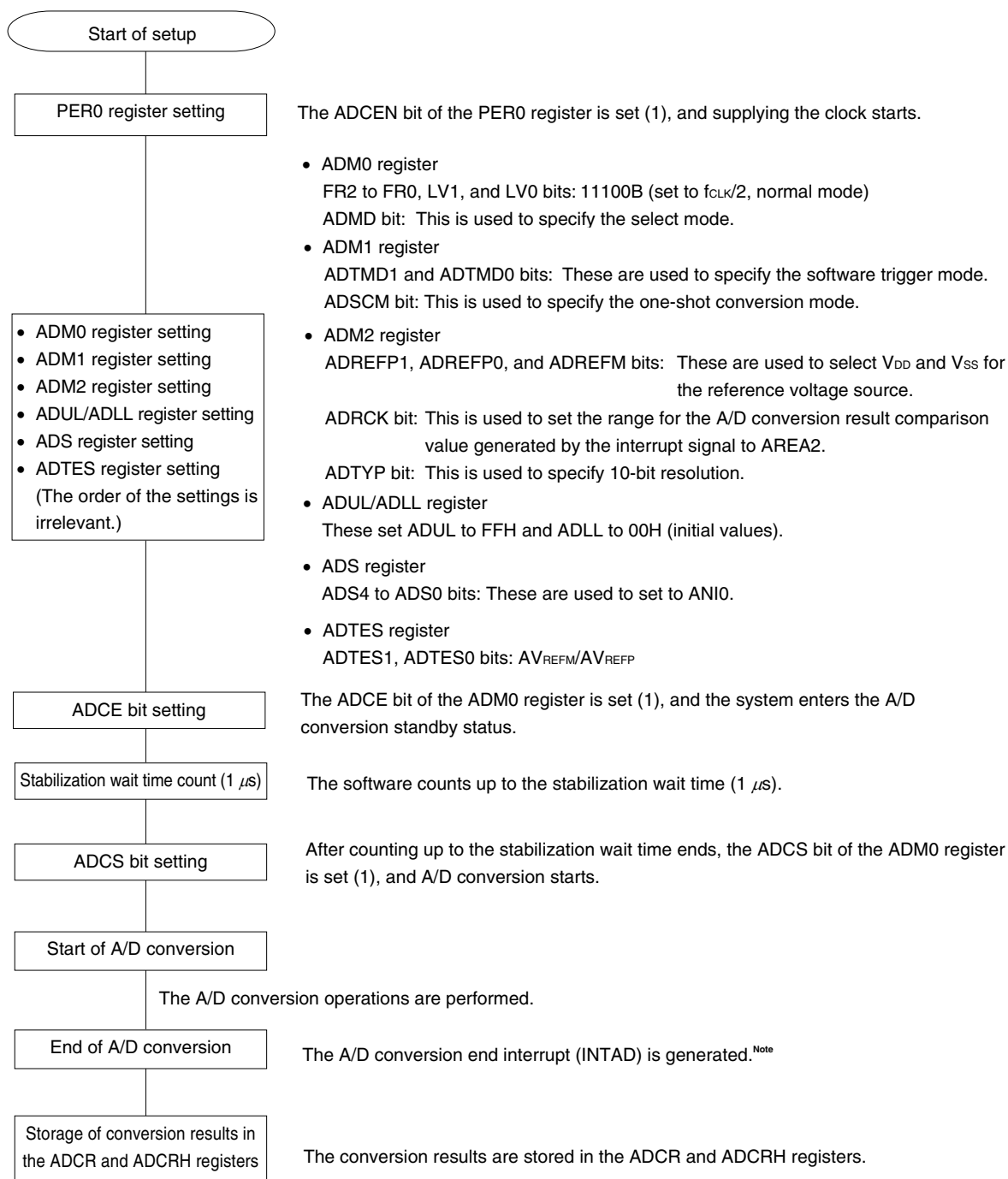
Figure 11-35. Setup When Using Temperature Sensor



**Note** Depending on the settings of the ADRCK bit and ADUL/ADLL register, there is a possibility of no interrupt signal being generated. In this case, the results are not stored in the ADCR, ADCRH registers.

11.7.5 Setting up test mode

Figure 11-36. Setting up Test Trigger Mode



**Note** Depending on the settings of the ADRCK bit and ADUL/ADLL register, there is a possibility of no interrupt signal being generated. In this case, the results are not stored in the ADCR, ADCRH registers.

## 11.8 SNOOZE Mode Function

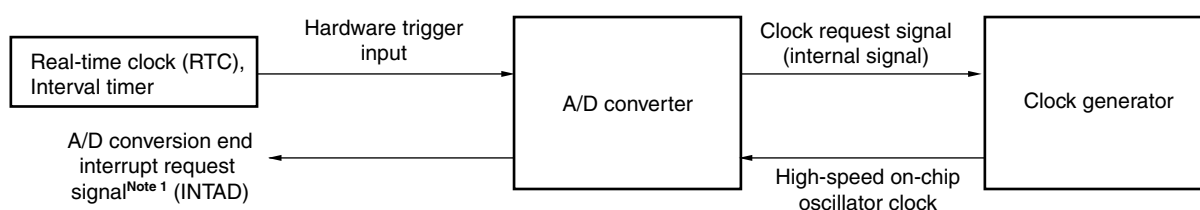
In the SNOOZE mode, A/D conversion is triggered by inputting a hardware trigger in the STOP mode. Normally, A/D conversion is stopped while in the STOP mode, but, by using the SNOOZE mode, A/D conversion can be performed without operating the CPU by inputting a hardware trigger. This is effective for reducing the operation current.

In the SNOOZE mode, only the following two conversion modes can be used:

- Hardware trigger wait mode (select mode, one-shot conversion mode)
- Hardware trigger wait mode (scan mode, one-shot conversion mode)

Note that the SNOOZE mode can only be specified when the high-speed on-chip oscillator clock is selected for  $f_{CLK}$ .

**Figure 11-37. Block Diagram When Using SNOOZE Mode Function**



When using the SNOOZE mode function, the initial setting of each register is specified before switching to the STOP mode. (For details about these settings, see **11.7.3 Setting up hardware trigger wait mode**<sup>Note 2.</sup>) At this time, bit 2 (AWC) of A/D converter mode register 2 (ADM2) is set to 1. After the initial settings are specified, bit 0 (ADCE) of A/D converter mode register 0 (ADM0) is set to 1.

If a hardware trigger is input after switching to the STOP mode, the high-speed on-chip oscillator clock is supplied to the A/D converter. After supplying this clock, the system automatically counts up to the stabilization wait time, and then A/D conversion starts.

The SNOOZE mode operation after A/D conversion ends differs depending on whether an interrupt signal is generated<sup>Note 1</sup>.

- Notes**
1. Depending on the setting of the A/D conversion result comparison function (ADRCK bit, ADUL/ADLL register), there is a possibility of no interrupt signal being generated.
  2. Be sure to set the ADM1 register to E2H or E3H.

**Remark** The hardware trigger is INTRTC or INTIT.

Specify the hardware trigger by using the A/D Converter Mode Register 1 (ADM1).



**(1) If an interrupt is generated after A/D conversion ends**

<R> If the A/D conversion result value is inside the range of values specified by the A/D conversion result comparison function (which is set up by using the ADRCK bit and ADUL/ADLL register), the A/D conversion end interrupt request signal (INTAD) is generated.

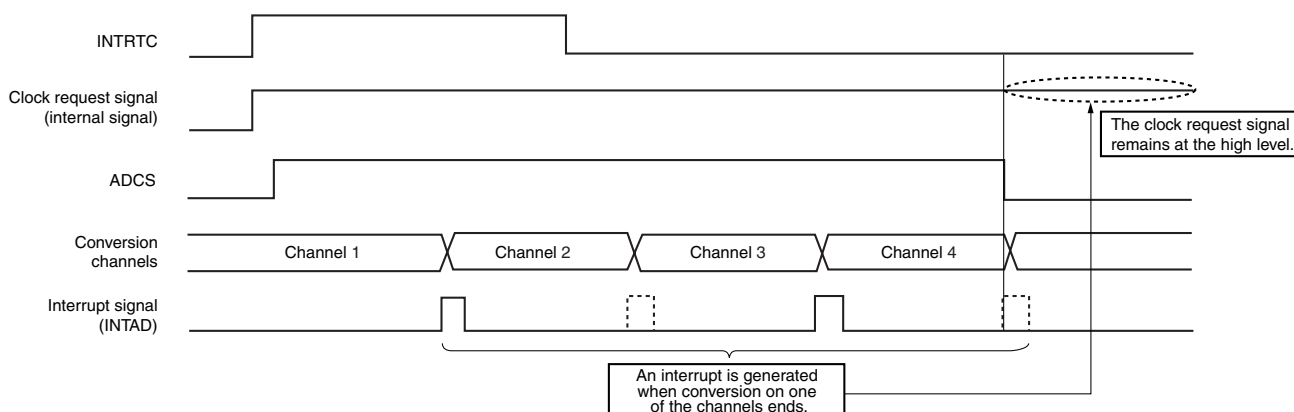
- While in the select mode

After A/D conversion ends and the A/D conversion end interrupt request signal (INTAD) is generated, the clock request signal remains at the high level, and the A/D converter switches from the SNOOZE mode to the normal operation mode. To stop the high-speed on-chip oscillator clock supplied while in the SNOOZE mode, clear bit 2 (AWC) of A/D converter mode register 2 (ADM2) to 0. Doing this sets the clock request signal (an internal signal) to the low level and stops the supply of the high-speed on-chip oscillator clock.

- While in the scan mode

If even one A/D conversion end interrupt request signal (INTAD) is generated during A/D conversion of the four channels, the clock request signal remains at the high level, and the A/D converter switches from the SNOOZE mode to the normal operation mode. To stop the high-speed on-chip oscillator clock supplied while in the SNOOZE mode, clear bit 2 (AWC) of A/D converter mode register 2 (ADM2) to 0. Doing this sets the clock request signal (an internal signal) to the low level and stops the supply of the high-speed on-chip oscillator clock.

**Figure 11-38. Operation Example When Interrupt Is Generated After A/D Conversion Ends (While in Scan Mode)**



**(2) If no interrupt is generated after A/D conversion ends**

If the A/D conversion result value is outside the range of values specified by the A/D conversion result comparison function (which is set up by using the ADRCK bit and ADUL/ADLL register), the A/D conversion end interrupt request signal (INTAD) is not generated.

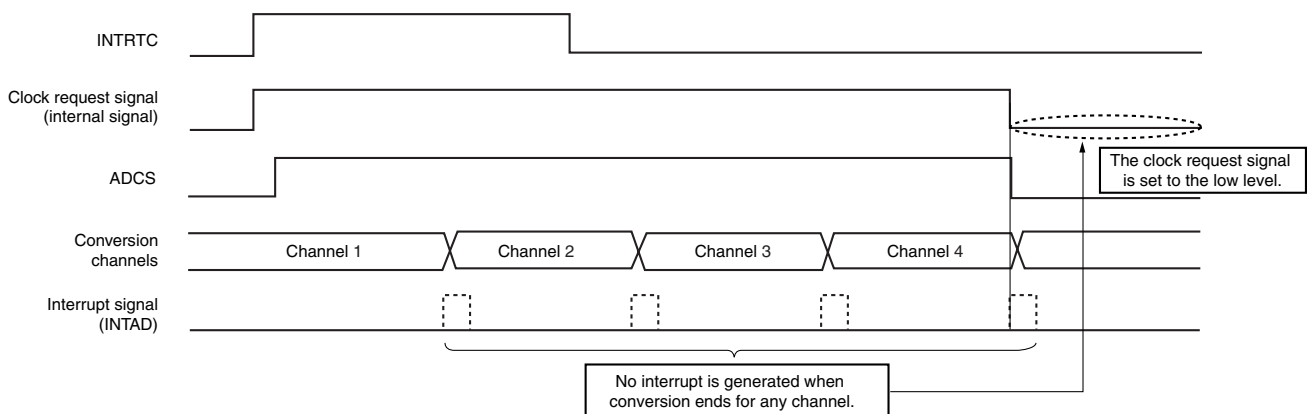
- While in the select mode

If the A/D conversion end interrupt request signal (INTAD) is not generated after A/D conversion ends, the clock request signal (an internal signal) is automatically set to the low level, and supplying the high-speed on-chip oscillator clock stops. If a hardware trigger is input later, A/D conversion work is again performed in the SNOOZE mode.

- While in the scan mode

If the A/D conversion end interrupt request signal (INTAD) is not generated even once during A/D conversion of the four channels, the clock request signal (an internal signal) is automatically set to the low level after A/D conversion of the four channels ends, and supplying the high-speed on-chip oscillator clock stops. If a hardware trigger is input later, A/D conversion work is again performed in the SNOOZE mode.

**Figure 11-39. Operation Example When No Interrupt Is Generated After A/D Conversion Ends (While in Scan Mode)**



### 11.9 How to Read A/D Converter Characteristics Table

Here, special terms unique to the A/D converter are explained.

#### (1) Resolution

This is the minimum analog input voltage that can be identified. That is, the percentage of the analog input voltage per bit of digital output is called 1LSB (Least Significant Bit). The percentage of 1LSB with respect to the full scale is expressed by %FSR (Full Scale Range).

1LSB is as follows when the resolution is 10 bits.

$$1\text{LSB} = 1/2^{10} = 1/1024$$

$$= 0.098\%\text{FSR}$$

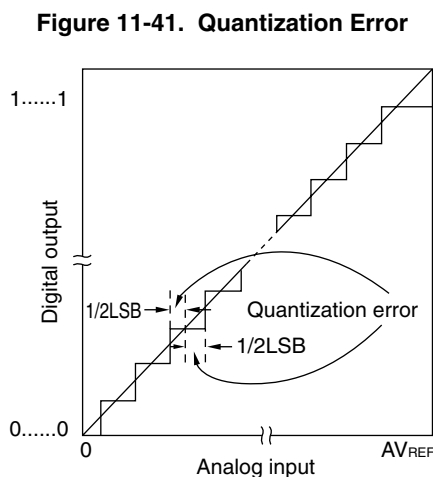
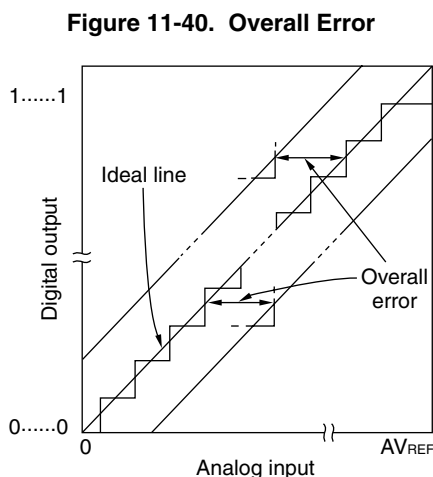
Accuracy has no relation to resolution, but is determined by overall error.

#### (2) Overall error

This shows the maximum error value between the actual measured value and the theoretical value. Zero-scale error, full-scale error, integral linearity error, and differential linearity errors that are combinations of these express the overall error. Note that the quantization error is not included in the overall error in the characteristics table.

#### (3) Quantization error

When analog values are converted to digital values, a  $\pm 1/2\text{LSB}$  error naturally occurs. In an A/D converter, an analog input voltage in a range of  $\pm 1/2\text{LSB}$  is converted to the same digital code, so a quantization error cannot be avoided. Note that the quantization error is not included in the overall error, zero-scale error, full-scale error, integral linearity error, and differential linearity error in the characteristics table.



#### (4) Zero-scale error

This shows the difference between the actual measurement value of the analog input voltage and the theoretical value ( $1/2\text{LSB}$ ) when the digital output changes from 0.....000 to 0.....001. If the actual measurement value is greater than the theoretical value, it shows the difference between the actual measurement value of the analog input voltage and the theoretical value ( $3/2\text{LSB}$ ) when the digital output changes from 0.....001 to 0.....010.

**(5) Full-scale error**

This shows the difference between the actual measurement value of the analog input voltage and the theoretical value (Full-scale - 3/2LSB) when the digital output changes from 1.....110 to 1.....111.

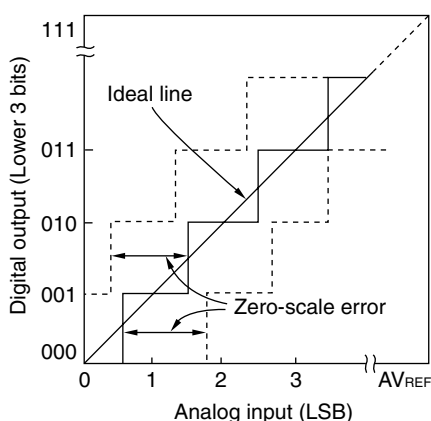
**(6) Integral linearity error**

This shows the degree to which the conversion characteristics deviate from the ideal linear relationship. It expresses the maximum value of the difference between the actual measurement value and the ideal straight line when the zero-scale error and full-scale error are 0.

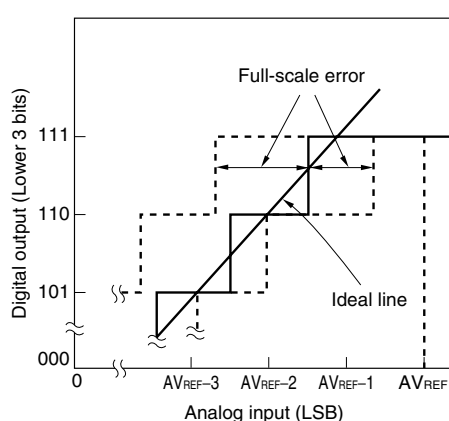
**(7) Differential linearity error**

While the ideal width of code output is 1LSB, this indicates the difference between the actual measurement value and the ideal value.

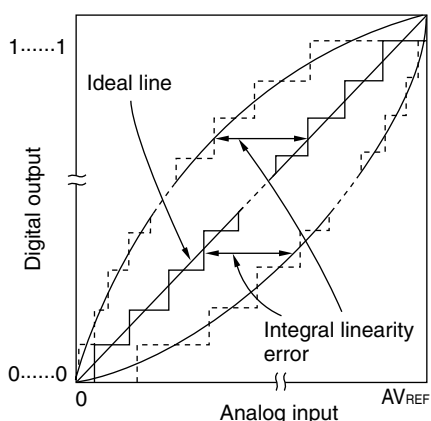
**Figure 11-42. Zero-Scale Error**



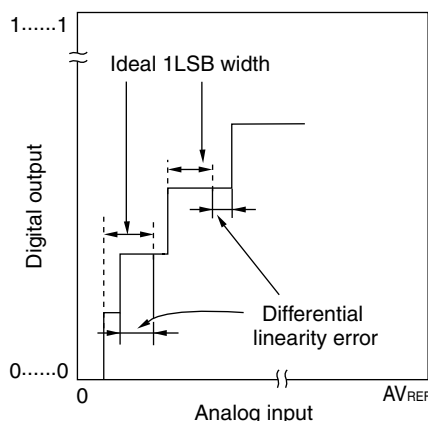
**Figure 11-43. Full-Scale Error**



**Figure 11-44. Integral Linearity Error**



**Figure 11-45. Differential Linearity Error**

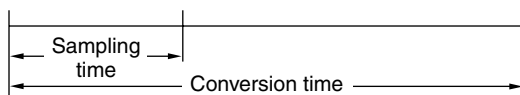


**(8) Conversion time**

This expresses the time from the start of sampling to when the digital output is obtained. The sampling time is included in the conversion time in the characteristics table.

**(9) Sampling time**

This is the time the analog switch is turned on for the analog voltage to be sampled by the sample & hold circuit.



### 11.10 Cautions for A/D Converter

#### (1) Operating current in STOP mode

Shift to STOP mode after stopping the A/D converter (by setting bit 7 (ADCS) of A/D converter mode register 0 (ADM0) to 0). The operating current can be reduced by setting bit 0 (ADCE) of the ADM0 register to 0 at the same time.

To restart from the standby status, clear bit 0 (ADIF) of interrupt request flag register 1H (IF1H) to 0 and start operation.

#### (2) Input range of ANI0 to ANI14 and ANI16 to ANI26 pins

Observe the rated range of the ANI0 to ANI14 and ANI16 to ANI26 pins input voltage. If a voltage of  $V_{DD}$  and  $AV_{REFP}$  or higher and  $V_{SS}$  and  $AV_{REFM}$  or lower (even in the range of absolute maximum ratings) is input to an analog input channel, the converted value of that channel becomes undefined. In addition, the converted values of the other channels may also be affected.

<R> When internal reference voltage (1.45 V) is selected reference voltage source for the + side of the A/D converter, do not input internal reference voltage or higher voltage to a pin selected by the ADS register. However, it is no problem that a pin not selected by the ADS register is inputted voltage greater than the internal reference voltage.

#### (3) Conflicting operations

<1> Conflict between the A/D conversion result register (ADCR, ADCRH) write and the ADCR or ADCRH register read by instruction upon the end of conversion

The ADCR or ADCRH register read has priority. After the read operation, the new conversion result is written to the ADCR or ADCRH registers.

<2> Conflict between the ADCR or ADCRH register write and the A/D converter mode register 0 (ADM0) write, the analog input channel specification register (ADS), or A/D port configuration register (ADPC) write upon the end of conversion

The ADM0, ADS, or ADPC registers write has priority. The ADCR or ADCRH register write is not performed, nor is the conversion end interrupt signal (INTAD) generated.

#### (4) Noise countermeasures

To maintain the 10-bit resolution, attention must be paid to noise input to the  $AV_{REFP}$ ,  $V_{DD}$ , ANI0 to ANI14, and ANI16 to ANI26 pins.

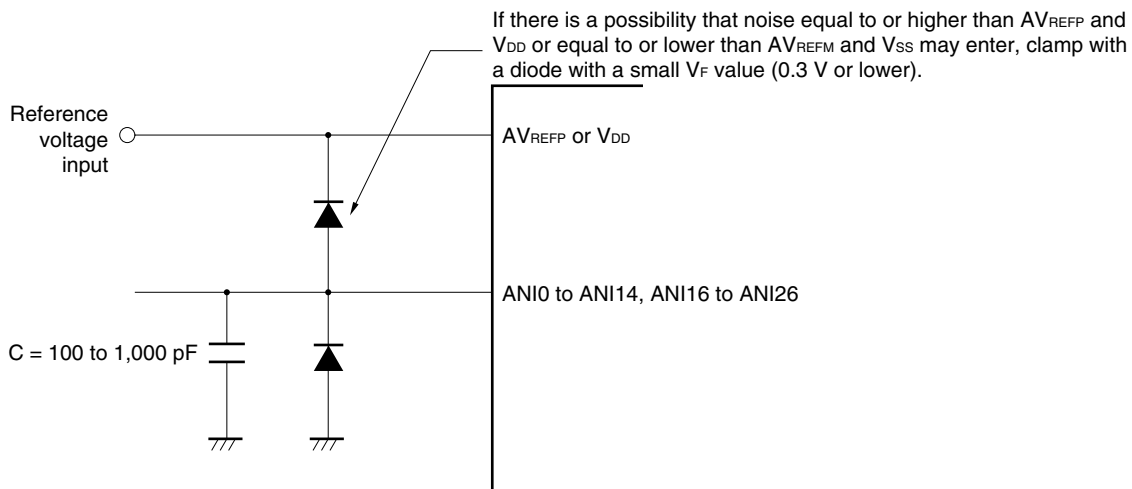
<1> Connect a capacitor with a low equivalent resistance and a good frequency response to the power supply.

<2> The higher the output impedance of the analog input source, the greater the influence. To reduce the noise, connecting external C as shown in Figure 11-46 is recommended.

<3> Do not switch these pins with other pins during conversion.

<4> The accuracy is improved if the HALT mode is set immediately after the start of conversion.

Figure 11-46. Analog Input Pin Connection



### (5) Analog input (ANIn) pins

<1> The analog input pins (ANI0 to ANI14, ANI16 to ANI26) are also used as input port pins (P20 to P27, P00 to P03, P35 to P37, P100, P115 to P117, P147, P120, P150 to P156).

When A/D conversion is performed with any of the ANI0 to ANI14 and ANI16 to ANI26 pins selected, do not access P20 to P27, P00 to P03, P35 to P37, P100, P115 to P117, P147, P120, P150 to P156 while conversion is in progress; otherwise the conversion resolution may be degraded.

<2> If a digital pulse is applied to the pins adjacent to the pins currently used for A/D conversion, the expected value of the A/D conversion may not be obtained due to coupling noise. Therefore, do not apply a pulse to the pins adjacent to the pin undergoing A/D conversion.

### (6) Input impedance of analog input (ANIn) pins

This A/D converter charges a sampling capacitor for sampling during sampling time.

Therefore, only a leakage current flows when sampling is not in progress, and a current that charges the capacitor flows during sampling. Consequently, the input impedance fluctuates depending on whether sampling is in progress, and on the other states.

To make sure that sampling is effective, however, it is recommended to keep the output impedance of the analog input source to within 1 k $\Omega$ , and to connect a capacitor of about 100 pF to the ANI0 to ANI14 and ANI16 to ANI26 pins (see Figure 11-46).

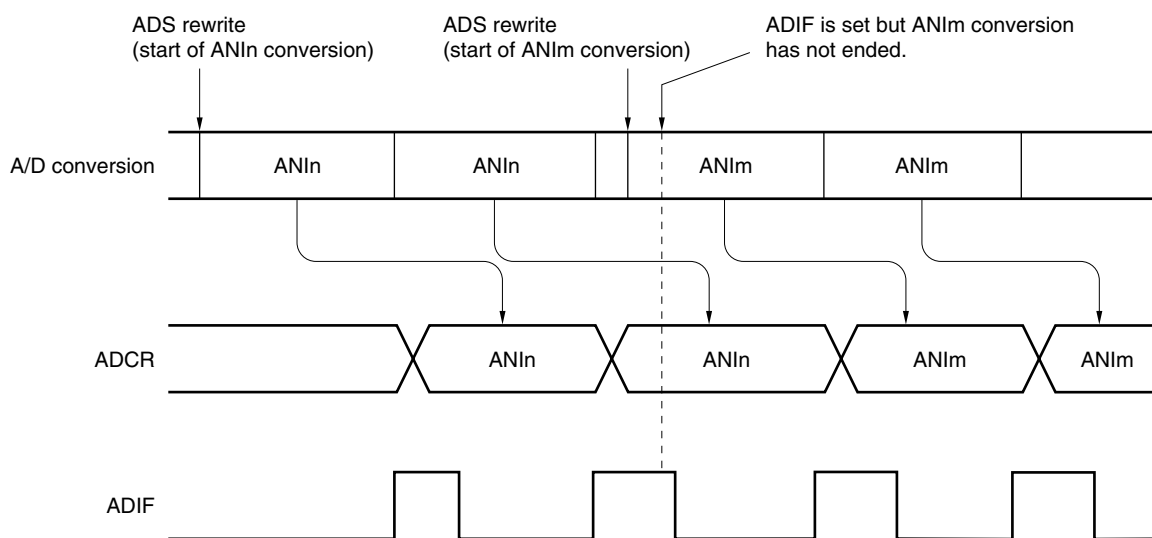
**(7) Interrupt request flag (ADIF)**

The interrupt request flag (ADIF) is not cleared even if the analog input channel specification register (ADS) is changed.

Therefore, if an analog input pin is changed during A/D conversion, the A/D conversion result and ADIF flag for the pre-change analog input may be set just before the ADS register rewrite. Caution is therefore required since, at this time, when ADIF flag is read immediately after the ADS register rewrite, ADIF flag is set despite the fact A/D conversion for the post-change analog input has not ended.

When A/D conversion is stopped and then resumed, clear ADIF flag before the A/D conversion operation is resumed.

**Figure 11-47. Timing of A/D Conversion End Interrupt Request Generation**



**(8) Conversion results just after A/D conversion start**

While in the software trigger mode or hardware trigger no-wait mode, the first A/D conversion value immediately after A/D conversion starts may not fall within the rating range if the ADCS bit is set to 1 within 1  $\mu$ s after the ADCE bit was set to 1. Take measures such as polling the A/D conversion end interrupt request (INTAD) and removing the first conversion result.

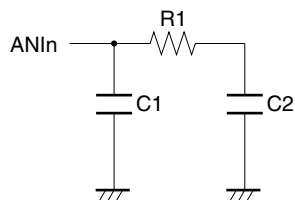
**(9) A/D conversion result register (ADCR, ADCRH) read operation**

When a write operation is performed to A/D converter mode register 0 (ADM0), analog input channel specification register (ADS), A/D port configuration register (ADPC), and port mode control register (PMC), the contents of the ADCR and ADCRH registers may become undefined. Read the conversion result following conversion completion before writing to the ADM0, ADS, ADPC, or PMC register. Using a timing other than the above may cause an incorrect conversion result to be read.

**(10) Internal equivalent circuit**

The equivalent circuit of the analog input block is shown below.

**Figure 11-47. Internal Equivalent Circuit of ANIn Pin**



<R>

**Table 11-6. Resistance and Capacitance Values of Equivalent Circuit (Reference Values)**

$AV_{REFP}, V_{DD}$	ANIn Pins	R1 [k $\Omega$ ]	C1 [pF]	C2 [pF]
$3.6\text{ V} \leq V_{DD} \leq 5.5\text{ V}$	ANI0 to ANI14	14	8	2.5
	ANI16 to ANI26	18	8	7.0
$1.6\text{ V} \leq V_{DD} < 3.6\text{ V}$	ANI0 to ANI14	632	8	2.5
	ANI16 to ANI26	902	8	7.0

**Remark** The resistance and capacitance values shown in Table 11-6 are not guaranteed values.

**(11) Starting the A/D converter**

Start the A/D converter after the  $AV_{REFP}$  and  $V_{DD}$  voltages stabilize.



## CHAPTER 12 SERIAL ARRAY UNIT

Serial array unit 0 has four serial channels, and serial array unit 1 has two. Each channel can achieve 3-wire serial (CSI), UART, and simplified I<sup>2</sup>C communication.

Function assignment of each channel supported by the RL78/G13 is as shown below.

- 20, 24, 25-pin products

Unit	Channel	Used as CSI	Used as UART	Used as Simplified I <sup>2</sup> C
0	0	CSI00	UART0	IIC00
	1	–		–
	2	–	UART1	–
	3	CSI11		IIC11
1	0	–	–	–
	1	–	–	–

- 30, 32-pin products

Unit	Channel	Used as CSI	Used as UART	Used as Simplified I <sup>2</sup> C
0	0	CSI00	UART0	IIC00
	1	–		–
	2	–	UART1	–
	3	CSI11		IIC11
1	0	CSI20	UART2 (supporting LIN-bus)	IIC20
	1	–		–

- 36, 40, 44-pin products

Unit	Channel	Used as CSI	Used as UART	Used as Simplified I <sup>2</sup> C
0	0	CSI00	UART0	IIC00
	1	–		–
	2	–	UART1	–
	3	CSI11		IIC11
1	0	CSI20	UART2 (supporting LIN-bus)	IIC20
	1	CSI21		IIC21

- 48, 52-pin products

Unit	Channel	Used as CSI	Used as UART	Used as Simplified I <sup>2</sup> C
0	0	CSI00	UART0	IIC00
	1	CSI01		IIC01
	2	–	UART1	–
	3	CSI11		IIC11
1	0	CSI20	UART2 (supporting LIN-bus)	IIC20
	1	CSI21		IIC21

- 64-pin products

Unit	Channel	Used as CSI	Used as UART	Used as Simplified I <sup>2</sup> C
0	0	CSI00	UART0	IIC00
	1	CSI01		IIC01
	2	CSI10	UART1	IIC10
	3	CSI11		IIC11
1	0	CSI20	UART2 (supporting LIN-bus)	IIC20
	1	CSI21		IIC21

- 80, 100, 128-pin products

Unit	Channel	Used as CSI	Used as UART	Used as Simplified I <sup>2</sup> C
0	0	CSI00	UART0	IIC00
	1	CSI01		IIC01
	2	CSI10	UART1	IIC10
	3	CSI11		IIC11
1	0	CSI20	UART2 (supporting LIN-bus)	IIC20
	1	CSI21		IIC21
	2	CSI30	UART3	IIC30
	3	CSI31		IIC31

When "UART0" is used for channels 0 and 1 of the unit 0, CSI00 and CSI01 cannot be used, but CSI10, UART1, or IIC10 can be used.

<R> **Caution** Most of the following descriptions in this chapter use the units and channels of the 128-pin products as an example.

## 12.1 Functions of Serial Array Unit

Each serial interface supported by the RL78/G13 has the following features.

### 12.1.1 3-wire serial I/O (CSI00, CSI01, CSI10, CSI11, CSI20, CSI21, CSI30, CSI31)

Data is transmitted or received in synchronization with the serial clock ( $\overline{\text{SCK}}$ ) output from the master channel.

3-wire serial communication is clocked communication performed by using three communication lines: one for the serial clock ( $\overline{\text{SCK}}$ ), one for transmitting serial data (SO), one for receiving serial data (SI).

For details about the settings, see **12.5 Operation of 3-Wire Serial I/O (CSI00, CSI01, CSI10, CSI11, CSI20, CSI21, CSI30, CSI31) Communication.**

[Data transmission/reception]

- Data length of 7 or 8 bits
- Phase control of transmit/receive data
- MSB/LSB first selectable
- Level setting of transmit/receive data

[Clock control]

- Master/slave selection
- Phase control of I/O clock
- Setting of transfer period by prescaler and internal counter of each channel
- Maximum transfer rate

During master communication (CSI00): Max.  $f_{\text{CLK}}/2$  <sup>Note</sup>

During master communication (other than CSI00): Max.  $f_{\text{CLK}}/4$  <sup>Note</sup>

During slave communication: Max.  $f_{\text{MCK}}/6$  <sup>Note</sup>

[Interrupt function]

- Transfer end interrupt/buffer empty interrupt

[Error detection flag]

- Overrun error

In addition, CSIs of following channels supports the SNOOZE mode. When  $\overline{\text{SCK}}$  input is detected while in the STOP mode, the SNOOZE mode makes data reception that does not require the CPU possible. Only following CSIs can be specified for asynchronous reception.

- <R>
- 20 to 64-pin products: CSI00
  - 80, 100, 128-pin products: CSI00 and CSI20

**Note** Use the clocks within a range satisfying the  $\overline{\text{SCK}}$  cycle time ( $t_{\text{KCY}}$ ) characteristics (see **CHAPTER 29 ELECTRICAL SPECIFICATIONS.**)

### 12.1.2 UART (UART0 to UART3)

This is a start-stop synchronization function using two lines: serial data transmission (TxD) and serial data reception (RxD) lines. By using these two communication lines, each data frame, which consist of a start bit, data, parity bit, and stop bit, is transferred asynchronously (using the internal baud rate) between the microcontroller and the other communication party. Full-duplex UART communication can be performed by using a channel dedicated to transmission (even-numbered channel) and a channel dedicated to reception (odd-numbered channel). The LIN-bus can be implemented by using timer array unit with an external interrupt (INTP0).

For details about the settings, see **12.6 Operation of UART (UART0 to UART3) Communication**.

[Data transmission/reception]

- Data length of 7, 8, or 9 bits
- Select the MSB/LSB first
- Level setting of transmit/receive data and select of reverse
- Parity bit appending and parity check functions
- Stop bit appending

[Interrupt function]

- Transfer end interrupt/buffer empty interrupt
- Error interrupt in case of framing error, parity error, or overrun error

[Error detection flag]

- Framing error, parity error, or overrun error

In addition, UARTs of following channels supports the SNOOZE mode. When RxD input is detected while in the STOP mode, the SNOOZE mode makes data reception that does not require the CPU possible. Only following UARTs can be specified for asynchronous reception.

- <R>
- 20 to 64-pin products:            UART0 only
  - 80, 100, 128-pin products:     UART0 and UART2 only

The LIN-bus is accepted in UART2 (0 and 1 channels of unit 1) (30, 32, 36, 40, 44, 48, 52, 64, 80, 100, and 128-pin products only).

[LIN-bus functions]

- Wakeup signal detection
- Sync break field (SBF) detection
- Sync field measurement, baud rate calculation

} Using the external interrupt (INTP0) and timer array unit

### 12.1.3 Simplified I<sup>2</sup>C (IIC00, IIC01, IIC10, IIC11, IIC20, IIC21, IIC30, IIC31)

This is a clocked communication function to communicate with two or more devices by using two lines: serial clock (SCL) and serial data (SDA). This simplified I<sup>2</sup>C is designed for single communication with a device such as EEPROM, flash memory, or A/D converter, and therefore, it functions only as a master.

Make sure by using software, as well as operating the control registers, that the AC specifications of the start and stop conditions are observed.

For details about the settings, see **12.8 Operation of Simplified I<sup>2</sup>C (IIC00, IIC01, IIC10, IIC11, IIC20, IIC21, IIC30, IIC31)**

[Data transmission/reception]

- Master transmission, master reception (only master function with a single master)
- ACK output function<sup>Note</sup> and ACK detection function
- Data length of 8 bits (When an address is transmitted, the address is specified by the higher 7 bits, and the least significant bit is used for R/W control.)
- Manual generation of start condition and stop condition

[Interrupt function]

- Transfer end interrupt

[Error detection flag]

- <R>
  - Parity error (ACK error), or overrun error

\* [Functions not supported by simplified I<sup>2</sup>C]

- Slave transmission, slave reception
- Arbitration loss detection function
- Wait detection functions

**Note** When receiving the last data, ACK will not be output if 0 is written to the SOEmn bit (serial output enable register m (SOEm)) and serial communication data output is stopped. See the processing flow in **12.8.3 (2)** for details.

**Remark** To use an I<sup>2</sup>C bus of full function, see **CHAPTER 13 SERIAL INTERFACE IICA**.

## 12.2 Configuration of Serial Array Unit

The serial array unit includes the following hardware.

**Table 12-1. Configuration of Serial Array Unit**

Item	Configuration
Shift register	8 bits or 9 bits <sup>Note 1</sup>
Buffer register	Lower 8 bits or 9 bits of serial data register mn (SDRmn) <sup>Notes 1, 2</sup>
Serial clock I/O	$\overline{SCK00}$ , $\overline{SCK01}$ , $\overline{SCK10}$ , $\overline{SCK11}$ , $\overline{SCK20}$ , $\overline{SCK21}$ , $\overline{SCK30}$ , $\overline{SCK31}$ pins (for 3-wire serial I/O), SCL00, SCL01, SCL10, SCL11, SCL20, SCL21, SCL30, SCL31 pins (for simplified I <sup>2</sup> C)
Serial data input	SI00, SI01, SI10, SI11, SI20, SI21, SI30, SI31 pins (for 3-wire serial I/O), RxD0, RxD1, RxD3 pins (for UART), RxD2 pin (for UART supporting LIN-bus)
Serial data output	SO00, SO01, SO10, SO11, SO20, SO21, SO30, SO31 pins (for 3-wire serial I/O), TxD0, TxD1, TxD3 pins (for UART), TxD2 pin (for UART supporting LIN-bus), output controller
Serial data I/O	SDA00, SDA01, SDA10, SDA11, SDA20, SDA21, SDA30, SDA31 pins (for simplified I <sup>2</sup> C)
Control registers	<Registers of unit setting block> <ul style="list-style-type: none"> <li>• Peripheral enable register 0 (PER0)</li> <li>• Serial clock select register m (SPSm)</li> <li>• Serial channel enable status register m (SEm)</li> <li>• Serial channel start register m (SSm)</li> <li>• Serial channel stop register m (STm)</li> <li>• Serial output enable register m (SOEm)</li> <li>• Serial output register m (SOM)</li> <li>• Serial output level register m (SOLm)</li> <li>• Serial standby control register m (SSCm)</li> <li>• Input switch control register (ISC)</li> <li>• Noise filter enable register 0 (NFEN0)</li> </ul>
	<Registers of each channel> <ul style="list-style-type: none"> <li>• Serial data register mn (SDRmn)</li> <li>• Serial mode register mn (SMRmn)</li> <li>• Serial communication operation setting register mn (SCRmn)</li> <li>• Serial status register mn (SSRmn)</li> <li>• Serial flag clear trigger register mn (SIRmn)</li> </ul>
	<ul style="list-style-type: none"> <li>• Port input mode registers 0, 1, 4, 5, 8, 14 (PIM0, PIM1, PIM4, PIM5, PIM8, PIM14)</li> <li>• Port output mode registers 0, 1, 4, 5, 7 to 9, 14 (POM0, POM1, POM4, POM5, POM7 to POM9, POM14)</li> <li>• Port mode registers 0, 1, 3 to 5, 7 to 9, 14 (PM0, PM1, PM3 to PM5, PM7 to PM9, PM14)</li> <li>• Port registers 0, 1, 3 to 5, 7 to 9, 14 (P0, P1, P3 to P5, P7 to P9, P14)</li> </ul>

- <R> **Notes** 1. The number of bits used as the shift register and buffer register differs depending on the unit and channel.
- 20 to 64-pin products and mn = 00, 01: lower 9 bits
  - 80, 100, 128-pin products and mn = 00, 01, 10, 11: lower 9 bits
  - Other than above: lower 8 bits
2. The lower 8 bits of serial data register mn (SDRmn) can be read or written as the following SFR, depending on the communication mode.
- CSIp communication ... SIOp (CSIp data register)
  - UARTq reception ... RXDq (UARTq receive data register)
  - UARTq transmission ... TXDq (UARTq transmit data register)
  - IICr communication ... SIOr (IICr data register)
- Remark** m: Unit number (m = 0, 1), n: Channel number (n = 0 to 3), p: CSI number (p = 00, 01, 10, 11, 20, 21, 30, 31), q: UART number (q = 0 to 3), r: IIC number (r = 00, 01, 10, 11, 20, 21, 30, 31)

Figure 12-1 shows the block diagram of the serial array unit 0.

Figure 12-1. Block Diagram of Serial Array Unit 0

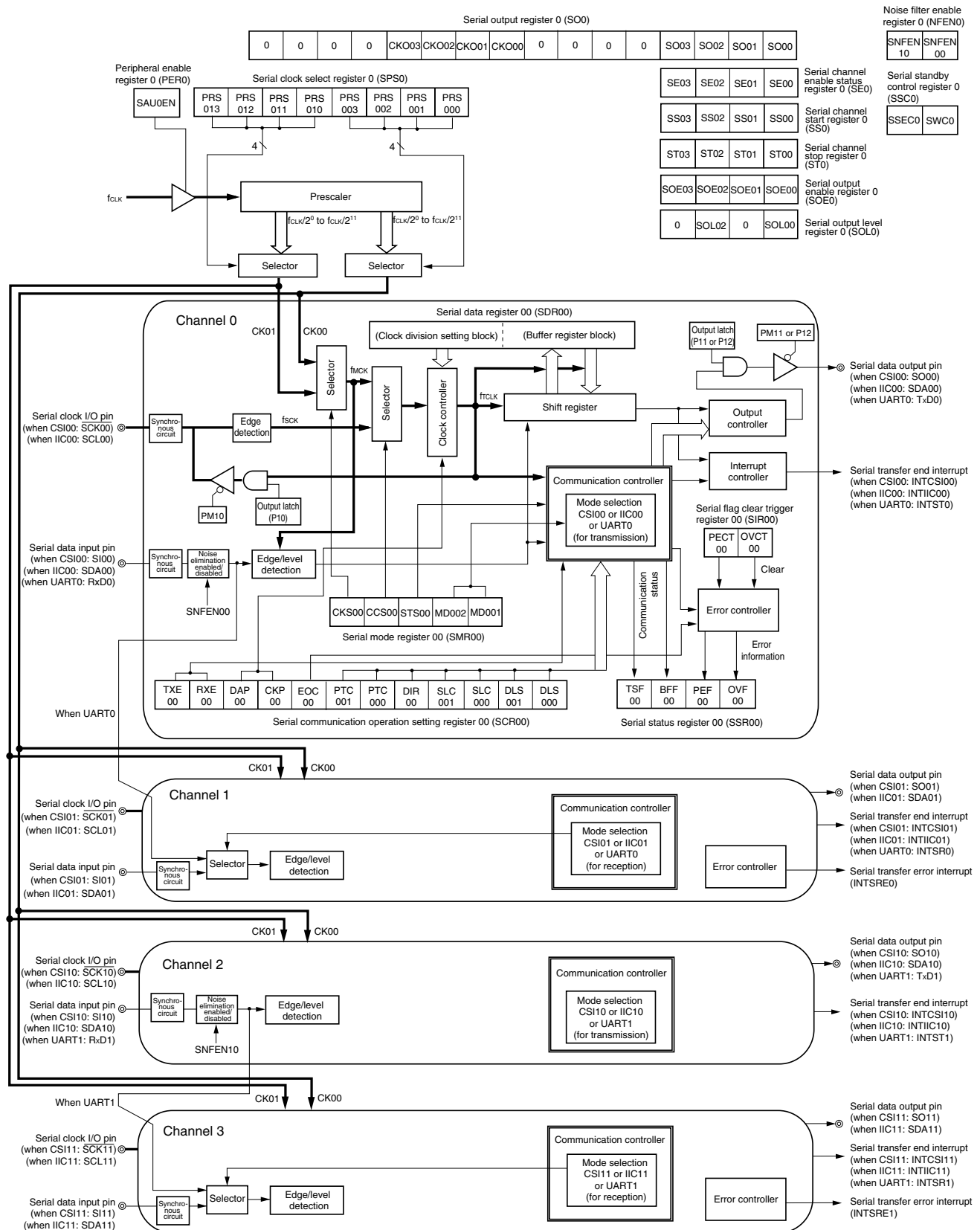
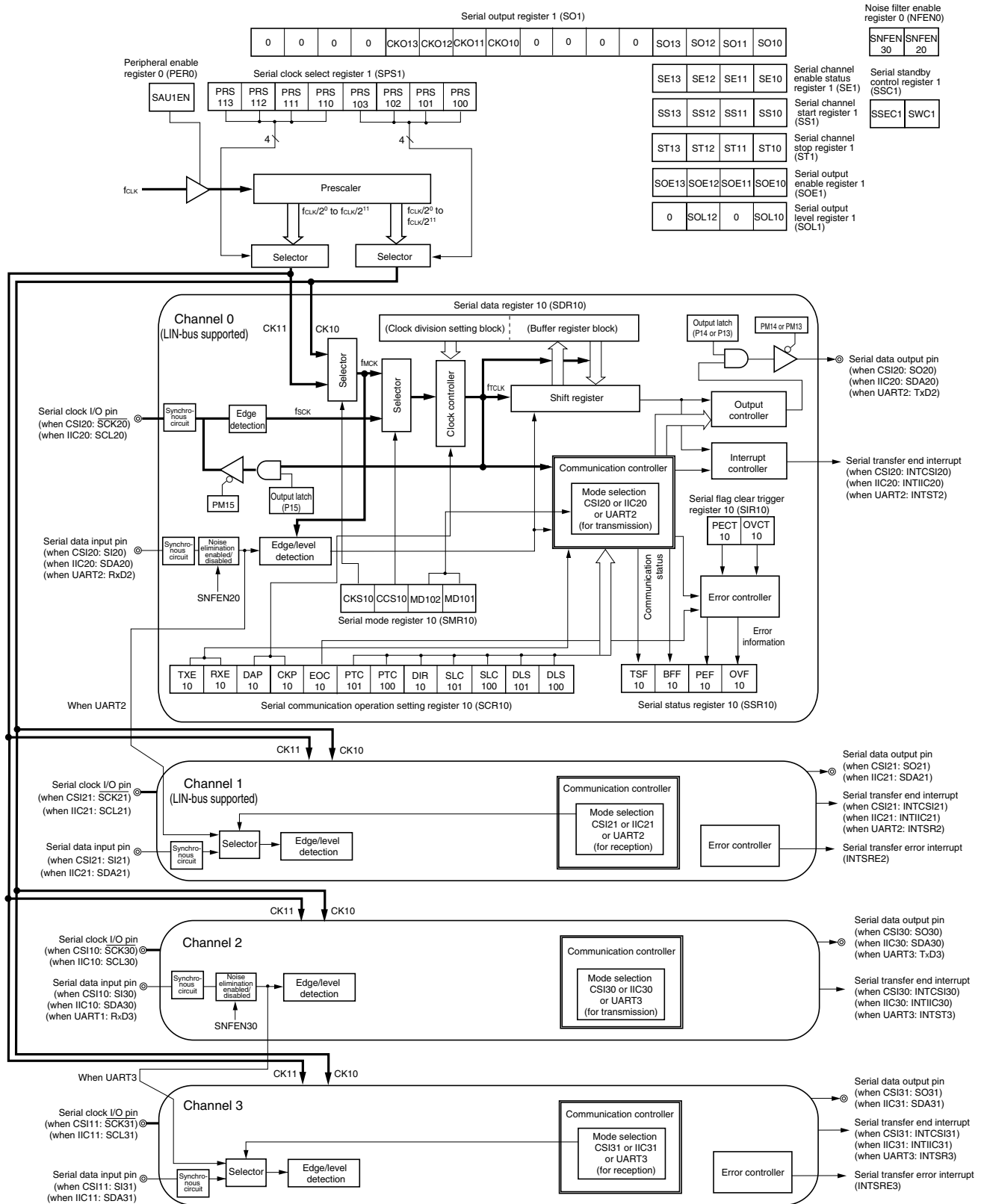




Figure 12-2 shows the block diagram of the serial array unit 1.

Figure 12-2. Block Diagram of Serial Array Unit 1

<R>



**(1) Shift register**

This is a 9-bit register that converts parallel data into serial data or vice versa.

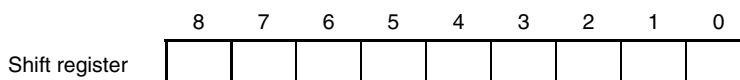
In case of the UART communication of nine bits of data, nine bits (bits 0 to 8) are used <sup>Note 1</sup>.

During reception, it converts data input to the serial pin into parallel data.

When data is transmitted, the value set to this register is output as serial data from the serial output pin.

The shift register cannot be directly manipulated by program.

To read or write the shift register, use the lower 8/9 bits of serial data register mn (SDRmn).

**(2) Lower 8/9 bits of the serial data register mn (SDRmn)**

The SDRmn register is the transmit/receive data register (16 bits) of channel n. Bits 8 to 0 (lower 9 bits) <sup>Note 1</sup> or bits 7 to 0 (lower 8 bits) function as a transmit/receive buffer register, and bits 15 to 9 are used as a register that sets the division ratio of the operation clock ( $f_{MCK}$ ).

When data is received, parallel data converted by the shift register is stored in the lower 8/9 bits. When data is to be transmitted, set transmit to be transferred to the shift register to the lower 8/9 bits.

The data stored in the lower 8/9 bits of this register is as follows, depending on the setting of bits 0 and 1 (DLSmn0, DLSmn1) of serial communication operation setting register mn (SCRmn), regardless of the output sequence of the data.

- 7-bit data length (stored in bits 0 to 6 of SDRmn register)
- 8-bit data length (stored in bits 0 to 7 of SDRmn register)
- 9-bit data length (stored in bits 0 to 8 of SDRmn register) <sup>Note 1</sup>

The SDRmn register can be read or written in 16-bit units.

The lower 8/9 bits of the SDRmn register can be read or written <sup>Note 2</sup> as the following SFR, depending on the communication mode.

- CSIp communication ... SIOp (CSIp data register)
- UARTq reception ... RXDq (UARTq receive data register)
- UARTq transmission ... TXDq (UARTq transmit data register)
- IICr communication ... SIOr (IICr data register)

Reset signal generation clears the SDRmn register to 0000H.

<R>

**Notes 1.** Only following UARTs can be specified for the 9-bit data length.

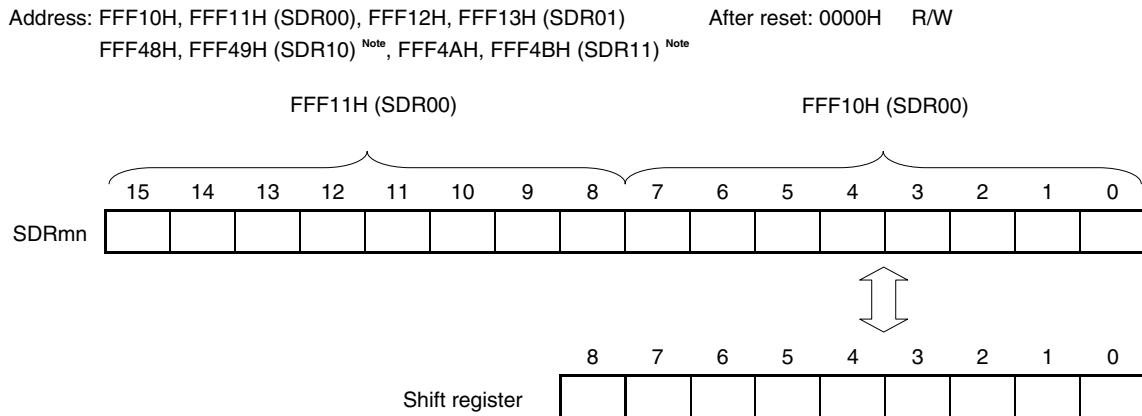
- 20 to 64-pin products: UART0
- 80, 100, 128-pin products: UART0, UART2

**2.** Writing in 8-bit units is prohibited when the operation is stopped (SEmn = 0).

**Remarks 1.** After data is received, "0" is stored in bits 0 to 8 in bit portions that exceed the data length.

- 2.** m: Unit number (m = 0, 1), n: Channel number (n = 0 to 3), p: CSI number (p = 00, 01, 10, 11, 20, 21, 30, 31), q: UART number (q = 0 to 3), r: IIC number (r = 00, 01, 10, 11, 20, 21, 30, 31)

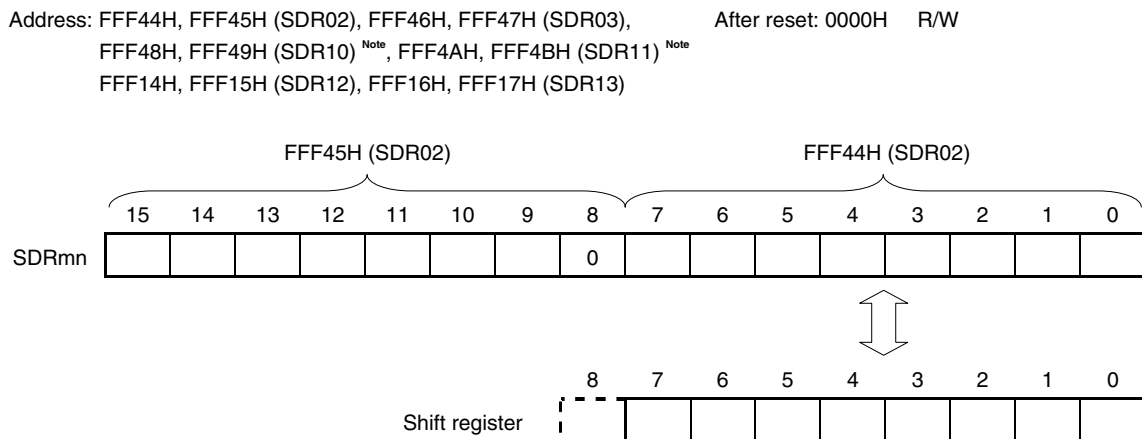
**Figure 12-3. Format of Serial Data Register mn (SDRmn) (mn = 00, 01, 10, 11)**



<R> **Note** 80, 100, 128-pin products

**Remark** For the function of the higher 7 bits of the SDRmn register, see **12.3 Registers Controlling Serial Array Unit**.

**Figure 12-4. Format of Serial Data Register mn (SDRmn) (mn = 02, 03, 10, 11, 12, 13)**



<R> **Note** 20 to 64-pin products

**Caution** Be sure to clear bit 8 to “0”.

**Remark** For the function of the higher 7 bits of the SDRmn register, see **12.3 Registers Controlling Serial Array Unit**.

### 12.3 Registers Controlling Serial Array Unit

Serial array unit is controlled by the following registers.

- Peripheral enable register 0 (PER0)
- Serial clock select register m (SPSm)
- Serial mode register mn (SMRmn)
- Serial communication operation setting register mn (SCRmn)
- Serial data register mn (SDRmn)
- Serial flag clear trigger register mn (SIRmn)
- Serial status register mn (SSRmn)
- Serial channel start register m (SSm)
- Serial channel stop register m (STm)
- Serial channel enable status register m (SEm)
- Serial output enable register m (SOEm)
- Serial output level register m (SOLm)
- Serial output register m (SOM)
- Serial standby control register m (SSCm)
- Input switch control register (ISC)
- Noise filter enable register 0 (NFEN0)
- Port input mode registers 0, 1, 4, 5, 8, 14 (PIM0, PIM1, PIM4, PIM5, PIM8, PIM14)
- Port output mode registers 0, 1, 4, 5, 7 to 9, 14 (POM0, POM1, POM4, POM5, POM7 to POM9, POM14)
- Port mode registers 0, 1, 3 to 5, 7 to 9, 14 (PM0, PM1, PM3 to PM5, PM7 to PM9, PM14)
- Port registers 0, 1, 3 to 5, 7 to 9, 14 (P0, P1, P3 to P5, P7 to P9, P14)

**Remark** m: Unit number (m = 0, 1), n: Channel number (n = 0 to 3)

**(1) Peripheral enable register 0 (PER0)**

PER0 is used to enable or disable supplying the clock to the peripheral hardware. Clock supply to a hardware macro that is not used is stopped in order to reduce the power consumption and noise.

When serial array unit 0 is used, be sure to set bit 2 (SAU0EN) of this register to 1.

When serial array unit 1 is used, be sure to set bit 3 (SAU1EN) of this register to 1.

The PER0 register can be set by a 1-bit or 8-bit memory manipulation instruction.

Reset signal generation clears the PER0 register to 00H.

**Figure 12-5. Format of Peripheral Enable Register 0 (PER0)**

Address: F00F0H After reset: 00H R/W

Symbol	<7>	<6>	<5>	<4>	<3>	<2>	<1>	<0>
PER0	RTCEN	IICA1EN <sup>Note 1</sup>	ADCEN	IICA0EN <sup>Note 2</sup>	SAU1EN <sup>Note 3</sup>	SAU0EN	TAU1EN <sup>Note 1</sup>	TAU0EN

SAUmEN	Control of serial array unit m input clock supply
0	Stops supply of input clock. <ul style="list-style-type: none"> <li>• SFR used by serial array unit m cannot be written.</li> <li>• Serial array unit m is in the reset status.</li> </ul>
1	Enables input clock supply. <ul style="list-style-type: none"> <li>• SFR used by serial array unit m can be read/written.</li> </ul>

- Notes**
1. 80, 100, and 128-pin products only.
  2. This is not provided in the 20-pin products.
  3. This is not provided in the 20, 24, and 25-pin products.

**Cautions**

1. When setting serial array unit m, be sure to set the SAUmEN bit to 1 first. If SAUmEN = 0, writing to a control register of serial array unit m is ignored, and, even if the register is read, only the default value is read (except for the input switch control register (ISC), noise filter enable register 0 (NFEN0), port input mode registers 0, 1, 4, 5, 8, 14 (PIM0, PIM1, PIM4, PIM5, PIM8, PIM14), port output mode registers 0, 1, 4, 5, 7 to 9, 14 (POM0, POM1, POM4, POM5, POM7 to POM9, POM14), port mode registers 0, 1, 3 to 5, 7 to 9, 14 (PM0, PM1, PM3 to PM5, PM7 to PM9, PM14), and port registers 0, 1, 3 to 5, 7 to 9, 14 (P0, P1, P3 to P5, P7 to P9, P14)).

2. Be sure to clear the following bits to 0.
  - 20-pin products: bits 1, 3, 4, 6
  - 24, 25-pin products: bits 1, 3, 6
  - 30, 32, 36, 40, 44, 48, 52, 64-pin products: bits 1, 6

<R>

**(2) Serial clock select register m (SPSm)**

The SPSm register is a 16-bit register that is used to select two types of operation clocks (CKm0, CKm1) that are commonly supplied to each channel. CKm1 is selected by bits 7 to 4 of the SPSm register, and CKm0 is selected by bits 3 to 0.

Rewriting the SPSm register is prohibited when the register is in operation (when SEMn = 1).

The SPSm register can be set by a 16-bit memory manipulation instruction.

The lower 8 bits of the SPSm register can be set with an 8-bit memory manipulation instruction with SPSmL.

Reset signal generation clears the SPSm register to 0000H.

**Figure 12-6. Format of Serial Clock Select Register m (SPSm)**

Address: F0126H, F0127H (SPS0), F0166H, F0167H (SPS1) After reset: 0000H R/W

Symbol	15	14	13	12	11	10	9	8	7	6	5	4	3	2	1	0
SPSm	0	0	0	0	0	0	0	0	PRS m13	PRS m12	PRS m11	PRS m10	PRS m03	PRS m02	PRS m01	PRS m00

PRS mk3	PRS mk2	PRS mk1	PRS mk0		Section of operation clock (CKmk) <sup>Note 1</sup>				
					f <sub>CLK</sub> = 2 MHz	f <sub>CLK</sub> = 5 MHz	f <sub>CLK</sub> = 10 MHz	f <sub>CLK</sub> = 20 MHz	f <sub>CLK</sub> = 32 MHz
0	0	0	0	f <sub>CLK</sub>	2 MHz	5 MHz	10 MHz	20 MHz	32 MHz
0	0	0	1	f <sub>CLK</sub> /2	1 MHz	2.5 MHz	5 MHz	10 MHz	16 MHz
0	0	1	0	f <sub>CLK</sub> /2 <sup>2</sup>	500 kHz	1.25 MHz	2.5 MHz	5 MHz	8 MHz
0	0	1	1	f <sub>CLK</sub> /2 <sup>3</sup>	250 kHz	625 kHz	1.25 MHz	2.5 MHz	4 MHz
0	1	0	0	f <sub>CLK</sub> /2 <sup>4</sup>	125 kHz	313 kHz	625 kHz	1.25 MHz	2 MHz
0	1	0	1	f <sub>CLK</sub> /2 <sup>5</sup>	62.5 kHz	156 kHz	313 kHz	625 kHz	1 MHz
0	1	1	0	f <sub>CLK</sub> /2 <sup>6</sup>	31.3 kHz	78.1 kHz	156 kHz	313 kHz	500 kHz
0	1	1	1	f <sub>CLK</sub> /2 <sup>7</sup>	15.6 kHz	39.1 kHz	78.1 kHz	156 kHz	250 kHz
1	0	0	0	f <sub>CLK</sub> /2 <sup>8</sup>	7.81 kHz	19.5 kHz	39.1 kHz	78.1 kHz	125 kHz
1	0	0	1	f <sub>CLK</sub> /2 <sup>9</sup>	3.91 kHz	9.77 kHz	19.5 kHz	39.1 kHz	62.5 kHz
1	0	1	0	f <sub>CLK</sub> /2 <sup>10</sup>	1.95 kHz	4.88 kHz	9.77 kHz	19.5 kHz	31.3 kHz
1	0	1	1	f <sub>CLK</sub> /2 <sup>11</sup>	977 Hz	2.44 kHz	4.88 kHz	9.77 kHz	15.6 kHz
1	1	0	0	f <sub>CLK</sub> /2 <sup>12</sup>	488 Hz	1.22 kHz	2.44 kHz	4.88 kHz	7.81 kHz
1	1	0	1	f <sub>CLK</sub> /2 <sup>13</sup>	244 Hz	610 Hz	1.22 kHz	2.44 kHz	3.91 kHz
1	1	1	0	f <sub>CLK</sub> /2 <sup>14</sup>	122 Hz	305 Hz	610 Hz	1.22 kHz	1.95 kHz
1	1	1	1	f <sub>CLK</sub> /2 <sup>15</sup>	61 Hz	153 kHz	305 Hz	610 Hz	977 Hz

<R>  
<R>  
<R>  
<R>

**Note** When changing the clock selected for f<sub>CLK</sub> (by changing the system clock control register (CKC) value), do so after having stopped (serial channel stop register m (STm) = 000FH) the operation of the serial array unit (SAU).

**Caution** Be sure to clear bits 15 to 8 to “0”.

- Remarks**
1. f<sub>CLK</sub>: CPU/peripheral hardware clock frequency  
f<sub>SUB</sub>: Subsystem clock frequency
  2. m: Unit number (m = 0, 1)
  3. k = 0, 1

**(3) Serial mode register mn (SMRmn)**

The SMRmn register is a register that sets an operation mode of channel n. It is also used to select an operation clock (fmck), specify whether the serial clock (fsck) may be input or not, set a start trigger, an operation mode (CSI, UART, or simplified I<sup>2</sup>C), and an interrupt source. This register is also used to invert the level of the receive data only in the UART mode.

Rewriting the SMRmn register is prohibited when the register is in operation (when SEMn = 1). However, the MDmn0 bit can be rewritten during operation.

The SMRmn register can be set by a 16-bit memory manipulation instruction.

Reset signal generation sets the SMRmn register to 0020H.

**Figure 12-7. Format of Serial Mode Register mn (SMRmn) (1/2)**

Address: F0110H, F0111H (SMR00) to F0116H, F0117H (SMR03), After reset: 0020H R/W  
 F0150H, F0151H (SMR10) to F0156H, F0157H (SMR13)

Symbol	15	14	13	12	11	10	9	8	7	6	5	4	3	2	1	0
SMRmn	CKS mn	CCS mn	0	0	0	0	0	STS mn <sup>Note</sup>	0	SIS mn0 <sup>Note</sup>	1	0	0	MD mn2	MD mn1	MD mn0

CKS mn	Selection of operation clock (fmck) of channel n
0	Operation clock CKm0 set by the SPSm register
1	Operation clock CKm1 set by the SPSm register
Operation clock (fmck) is used by the edge detector. In addition, depending on the setting of the CCSmn bit and the higher 7 bits of the SDRmn register, a transfer clock (ftclk) is generated.	

CCS mn	Selection of transfer clock (ftclk) of channel n
0	Divided operation clock fmck specified by the CKSmn bit
1	Clock input fsck from the SCKp pin (slave transfer in CSI mode)
Transfer clock ftclk is used for the shift register, communication controller, output controller, interrupt controller, and error controller. When CCSmn = 0, the division ratio of operation clock (fmck) is set by the higher 7 bits of the SDRmn register.	

STS mn	Selection of start trigger source
0	Only software trigger is valid (selected for CSI, UART transmission, and simplified I <sup>2</sup> C).
1	Valid edge of the RxDq pin (selected for UART reception)
Transfer is started when the above source is satisfied after 1 is set to the SSm register.	

**Note** The SMR01, SMR03, SMR11, and SMR13 registers only.

**Caution** Be sure to clear bits 13 to 9, 7, 4, and 3 (or bits 13 to 6, 4, and 3 for the SMR00, SMR02, SMR10, or SMR12 register) to “0”. Be sure to set bit 5 to “1”.

**Remark** m: Unit number (m = 0, 1), n: Channel number (n = 0 to 3), p: CSI number (p = 00, 01, 10, 11, 20, 21, 30, 31), q: UART number (q = 0 to 3), r: IIC number (r = 00, 01, 10, 11, 20, 21, 30, 31)



**Figure 12-7. Format of Serial Mode Register mn (SMRmn) (2/2)**

Address: F0110H, F0111H (SMR00) to F0116H, F0117H (SMR03), After reset: 0020H R/W  
 F0150H, F0151H (SMR10) to F0156H, F0157H (SMR13)

Symbol	15	14	13	12	11	10	9	8	7	6	5	4	3	2	1	0
SMRmn	CKS mn	CCS mn	0	0	0	0	0	STS mn <sup>Note</sup>	0	SIS mn0 <sup>Note</sup>	1	0	0	MD mn2	MD mn1	MD mn0

SIS mn0	Controls inversion of level of receive data of channel n in UART mode	
0	Falling edge is detected as the start bit. The input communication data is captured as is.	
1	Rising edge is detected as the start bit. The input communication data is inverted and captured.	

MD mn2	MD mn1	Setting of operation mode of channel n	
0	0	CSI mode	
0	1	UART mode	
1	0	Simplified I <sup>2</sup> C mode	
1	1	Setting prohibited	

MD mn0	Selection of interrupt source of channel n	
0	Transfer end interrupt	
1	Buffer empty interrupt (Occurs when data is transferred from the SDRmn register to the shift register.)	
For successive transmission, the next transmit data is written by setting the MDmn0 bit to 1 when SDRmn data has run out.		

**Note** The SMR01, SMR03, SMR11, and SMR13 registers only.

**Caution** Be sure to clear bits 13 to 9, 7, 4, and 3 (or bits 13 to 6, 4, and 3 for the SMR00, SMR02, SMR10, or SMR12 register) to “0”. Be sure to set bit 5 to “1”.

**Remark** m: Unit number (m = 0, 1), n: Channel number (n = 0 to 3), p: CSI number (p = 00, 01, 10, 11, 20, 21, 30, 31), q: UART number (q = 0 to 3), r: IIC number (r = 00, 01, 10, 11, 20, 21, 30, 31)

#### (4) Serial communication operation setting register mn (SCRmn)

The SCRmn register is a communication operation setting register of channel n. It is used to set a data transmission/reception mode, phase of data and clock, whether an error signal is to be masked or not, parity bit, start bit, stop bit, and data length.

Rewriting the SCRmn register is prohibited when the register is in operation (when SEMn = 1).

The SCRmn register can be set by a 16-bit memory manipulation instruction.

Reset signal generation sets the SCRmn register to 0087H.

**Figure 12-8. Format of Serial Communication Operation Setting Register mn (SCRmn) (1/2)**

Address: F0118H, F0119H (SCR00) to F011EH, F011FH (SCR03), After reset: 0087H R/W  
 F0158H, F0159H (SCR10) to F015EH, F015FH (SCR13)

Symbol	15	14	13	12	11	10	9	8	7	6	5	4	3	2	1	0
SCRmn	TXE mn	RXE mn	DAP mn	CKP mn	0	EOC mn	PTC mn1	PTC mn0	DIR mn	0	SLCm n1 <sup>Note 1</sup>	SLC mn0	0	1	DLSm n1 <sup>Note 2</sup>	DLS mn0

TXE mn	RXE mn	Setting of operation mode of channel n
0	0	Disable communication.
0	1	Reception only
1	0	Transmission only
1	1	Transmission/reception

DAP mn	CKP mn	Selection of data and clock phase in CSI mode	Type
0	0		1
0	1		2
1	0		3
1	1		4

Be sure to set DAPmn, CKPmn = 0, 0 in the UART mode and simplified I<sup>2</sup>C mode.

EOC mn	Selection of masking of error interrupt signal (INTSREx (x = 0 to 3))
0	Masks error interrupt INTSREx (INTSRx is not masked).
1	Enables generation of error interrupt INTSREx (INTSRx is masked if an error occurs).

Set EOCmn = 0 in the CSI mode, simplified I<sup>2</sup>C mode, and during UART transmission<sup>Note 3</sup>.  
 Set EOCmn = 1 during UART reception.

**Notes 1.** The SCR00, SCR02, SCR10, and SCR12 registers only.

- <R> **2.** The SCR00 and SCR01 registers and SCR10 and SCR11 registers for 80, 100 and 128-pins products only. Others are fixed to 1.
- 3.** When using CSI01 not with EOC01 = 0, error interrupt INTSRE0 may be generated.

<R> **Caution** Be sure to clear bits 3, 6, and 11 to “0”. (Also clear bit 5 of the SCR01, SCR03, SCR11, or SCR13 register to 0, as well as bit 1 of the SCR02, SCR03, SCR12, SCR13 registers, and SCR10, or SCR11 registers for 20 to 64-pin products.). Be sure to set bit 2 to “1”.

**Remark** m: Unit number (m = 0, 1), n: Channel number (n = 0 to 3), p: CSI number (p = 00, 01, 10, 11, 20, 21, 30, 31)

**Figure 12-8. Format of Serial Communication Operation Setting Register mn (SCRmn) (2/2)**

Address: F0118H, F0119H (SCR00) to F011EH, F011FH (SCR03), After reset: 0087H R/W  
 F0158H, F0159H (SCR10) to F015EH, F015FH (SCR13)

Symbol	15	14	13	12	11	10	9	8	7	6	5	4	3	2	1	0
SCRmn	TXE mn	RXE mn	DAP mn	CKP mn	0	EOC mn	PTC mn1	PTC mn0	DIR mn	0	SLCm n1 <sup>Note 1</sup>	SLC mn0	0	1	DLSm n1 <sup>Note 2</sup>	DLS mn0

PTC mn1	PTC mn0	Setting of parity bit in UART mode			
		Transmission		Reception	
0	0	Does not output the parity bit.		Receives without parity	
0	1	Outputs 0 parity <sup>Note 3</sup> .		No parity judgment	
1	0	Outputs even parity.		Judged as even parity.	
1	1	Outputs odd parity.		Judges as odd parity.	
Be sure to set PTCmn1, PTCmn0 = 0, 0 in the CSI mode and simplified I <sup>2</sup> C mode.					

DIR mn	Selection of data transfer sequence in CSI and UART modes			
	0	Inputs/outputs data with MSB first.		
	1	Inputs/outputs data with LSB first.		
Be sure to clear DIRmn = 0 in the simplified I <sup>2</sup> C mode.				

SLCm n1 <sup>Note 1</sup>	SLC mn0	Setting of stop bit in UART mode			
		0	0	No stop bit	
		0	1	Stop bit length = 1 bit	
		1	0	Stop bit length = 2 bits (mn = 00, 02, 10, 12 only)	
		1	1	Setting prohibited	
When the transfer end interrupt is selected, the interrupt is generated when all stop bits have been completely transferred. Set 1 bit (SLCmn1, SLCmn0 = 0, 1) during UART reception and in the simplified I <sup>2</sup> C mode. Set no stop bit (SLCmn1, SLCmn0 = 0, 0) in the CSI mode.					

DLSm n1 <sup>Note 2</sup>	DLS mn0	Setting of data length in CSI and UART modes			
		0	1	9-bit data length (stored in bits 0 to 8 of the SDRmn register) (settable in UART mode only)	
		1	0	7-bit data length (stored in bits 0 to 6 of the SDRmn register)	
		1	1	8-bit data length (stored in bits 0 to 7 of the SDRmn register)	
		Other than above		Setting prohibited	
Be sure to set DLSmn1, DLSmn0 = 1, 1 in the simplified I <sup>2</sup> C mode.					

**Notes 1.** The SCR00, SCR02, SCR10, and SCR12 registers only.

- <R> **2.** The SCR00 and SCR01 registers and SCR10 and SCR11 registers for 80, 100 and 128-pins products only. Others are fixed to 1.
- 3.** 0 is always added regardless of the data contents.

<R> **Caution** Be sure to clear bits 3, 6, and 11 to “0”. (Also clear bit 5 of the SCR01, SCR03, SCR11, or SCR13 register to 0, as well as bit 1 of the SCR02, SCR03, SCR12, SCR13 registers, and SCR10, or SCR11 registers for 20 to 64-pin products.). Be sure to set bit 2 to “1”.

**Remark** m: Unit number (m = 0, 1), n: Channel number (n = 0 to 3), p: CSI number (p = 00, 01, 10, 11, 20, 21, 30, 31)

**(5) Higher 7 bits of the serial data register mn (SDRmn)**

<R> The SDRmn register is the transmit/receive data register (16 bits) of channel n. Bits 8 to 0 (lower 9 bits) of SDR00, SDR01, SDR10<sup>Note 1</sup>, SDR11<sup>Note 1</sup> or bits 7 to 0 (lower 8 bits) of SDR02, SDR03, SDR10<sup>Note 2</sup>, SDR11<sup>Note 2</sup>, SDR12 and SDR13 function as a transmit/receive buffer register, and bits 15 to 9 are used as a register that sets the division ratio of the operation clock (f<sub>MCK</sub>).

If the CCSmn bit of serial mode register mn (SMRmn) is cleared to 0, the clock set by dividing the operating clock by the higher 7 bits of the SDRmn register is used as the transfer clock.

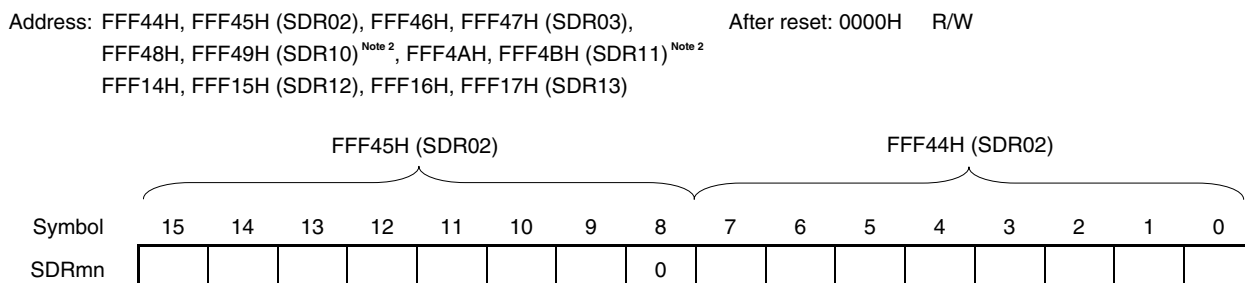
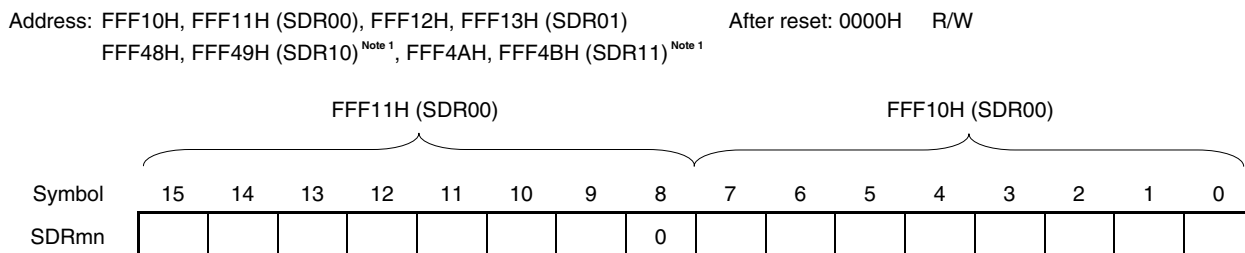
The lower 8/9 bits of the SDRmn register function as a transmit/receive buffer register. During reception, the parallel data converted by the shift register is stored in the lower 8/9 bits, and during transmission, the data to be transmitted to the shift register is set to the lower 8/9 bits.

The SDRmn register can be read or written in 16-bit units.

However, the higher 7 bits can be written or read only when the operation is stopped (SEmn = 0). During operation (SEmn = 1), a value is written only to the lower 8/9 bits of the SDRmn register. When the SDRmn register is read during operation, 0 is always read.

Reset signal generation clears the SDRmn register to 0000H.

**Figure 12-9. Format of Serial Data Register mn (SDRmn)**



SDRmn[15:9]							Transfer clock setting by dividing the operating clock (f <sub>MCK</sub> )
0	0	0	0	0	0	0	f <sub>MCK</sub> /2
0	0	0	0	0	0	1	f <sub>MCK</sub> /4
0	0	0	0	0	1	0	f <sub>MCK</sub> /6
0	0	0	0	0	1	1	f <sub>MCK</sub> /8
•	•	•	•	•	•	•	•
•	•	•	•	•	•	•	•
•	•	•	•	•	•	•	•
1	1	1	1	1	1	0	f <sub>MCK</sub> /254
1	1	1	1	1	1	1	f <sub>MCK</sub> /256

- Notes**
- 20, 100 and 128-pin products
  - 20 to 64-pin products

(Cautions and remarks are listed on the next page.)

- Cautions**
1. Be sure to clear bit 8 of the SDR02, SDR03, SDR12, SDR13, and SDR10, and SDR11 of 20 to 64-pin products to “0”.
  2. Setting SDRmn[15:9] = (0000000B, 0000001B) is prohibited when UART is used.
  3. Setting SDRmn[15:9] = 0000000B is prohibited when simplified I<sup>2</sup>C is used. Set SDRmn[15:9] to 0000001B or greater.
  4. Do not write eight bits to the lower eight bits if operation is stopped (SEmn = 0). (If these bits are written to, the higher seven bits are cleared to 0.)

- Remarks**
1. For the function of the lower 8/9 bits of the SDRmn register, see **12.2 Configuration of Serial Array Unit**.
  2. m: Unit number (m = 0, 1), n: Channel number (n = 0 to 3)

**(6) Serial flag clear trigger register mn (SIRmn)**

The SIRmn register is a trigger register that is used to clear each error flag of channel n.

When each bit (FECTmn, PECTmn, OVCTmn) of this register is set to 1, the corresponding bit (FEFmn, PEFmn, OVFmn) of serial status register mn is cleared to 0. Because the SIRmn register is a trigger register, it is cleared immediately when the corresponding bit of the SSRmn register is cleared.

The SIRmn register can be set by a 16-bit memory manipulation instruction.

The lower 8 bits of the SIRmn register can be set with an 8-bit memory manipulation instruction with SIRmnL.

Reset signal generation clears the SIRmn register to 0000H.

**Figure 12-10. Format of Serial Flag Clear Trigger Register mn (SIRmn)**

Address: F0108H, F0109H (SIR00) to F010EH, F010FH (SIR03), After reset: 0000H R/W  
 F0148H, F0149H (SIR10) to F014EH, F014FH (SIR13)

Symbol	15	14	13	12	11	10	9	8	7	6	5	4	3	2	1	0
SIRmn	0	0	0	0	0	0	0	0	0	0	0	0	0	FECT mn <sup>Note</sup>	PEC Tmn	OVC Tmn

FEC Tmn	Clear trigger of framing error of channel n
0	Not cleared
1	Clears the FEFmn bit of the SSRmn register to 0.

PEC Tmn	Clear trigger of parity error flag of channel n
0	Not cleared
1	Clears the PEFmn bit of the SSRmn register to 0.

OVC Tmn	Clear trigger of overrun error flag of channel n
0	Not cleared
1	Clears the OVFmn bit of the SSRmn register to 0.

**Note** The SIR01, SIR03, SIR11, and SIR13 registers only.

**Caution** Be sure to clear bits 15 to 3 (or bits 15 to 2 for the SIR00, SIR02, SIR10, or SIR12 register) to “0”.

- Remarks**
1. m: Unit number (m = 0, 1), n: Channel number (n = 0 to 3)
  2. When the SIRmn register is read, 0000H is always read.

**(7) Serial status register mn (SSRmn)**

The SSRmn register is a register that indicates the communication status and error occurrence status of channel n. The errors indicated by this register are a framing error, parity error, and overrun error.

The SSRmn register can be read by a 16-bit memory manipulation instruction.

The lower 8 bits of the SSRmn register can be set with an 8-bit memory manipulation instruction with SSRmnL. Reset signal generation clears the SSRmn register to 0000H.

**Figure 12-11. Format of Serial Status Register mn (SSRmn) (1/2)**

Address: F0100H, F0101H (SSR00) to F0106H, F0107H (SSR03), After reset: 0000H R  
 F0140H, F0141H (SSR10) to F0146H, F0147H (SSR13)

Symbol	15	14	13	12	11	10	9	8	7	6	5	4	3	2	1	0
SSRmn	0	0	0	0	0	0	0	0	0	TSF mn	BFF mn	0	0	FEFm n <sup>Note</sup>	PEF mn	OVF mn

TSF mn	Communication status indication flag of channel n
0	Communication is stopped or suspended.
1	Communication is in progress.
<Clear conditions> <ul style="list-style-type: none"> <li>• The STmn bit of the STm register is set to 1 (communication is stopped) or the SSmn bit of the SSm register is set to 1 (communication is suspended).</li> <li>• Communication ends.</li> </ul> <Set condition> <ul style="list-style-type: none"> <li>• Communication starts.</li> </ul>	

BFF mn	Buffer register status indication flag of channel n
0	Valid data is not stored in the SDRmn register.
1	Valid data is stored in the SDRmn register.
<Clear conditions> <ul style="list-style-type: none"> <li>• Transferring transmit data from the SDRmn register to the shift register ends during transmission.</li> <li>• Reading receive data from the SDRmn register ends during reception.</li> <li>• The STmn bit of the STm register is set to 1 (communication is stopped) or the SSmn bit of the SSm register is set to 1 (communication is enabled).</li> </ul> <Set conditions> <ul style="list-style-type: none"> <li>• Transmit data is written to the SDRmn register while the TXEmn bit of the SCRmn register is set to 1 (transmission or transmission and reception mode in each communication mode).</li> <li>• Receive data is stored in the SDRmn register while the RXEmn bit of the SCRmn register is set to 1 (reception or transmission and reception mode in each communication mode).</li> <li>• A reception error occurs.</li> </ul>	

**Note** The SSR01, SSR03, SSR11, and SSR13 registers only.

**Caution** If data is written to the SDRmn register when BFFmn = 1, the transmit/receive data stored in the register is discarded and an overrun error (OVEmn = 1) is detected.

**Remark** m: Unit number (m = 0, 1), n: Channel number (n = 0 to 3)

**Figure 12-11. Format of Serial Status Register mn (SSRmn) (2/2)**

Address: F0100H, F0101H (SSR00) to F0106H, F0107H (SSR03), After reset: 0000H R  
 F0140H, F0141H (SSR10) to F0146H, F0147H (SSR13)

Symbol	15	14	13	12	11	10	9	8	7	6	5	4	3	2	1	0
SSRmn	0	0	0	0	0	0	0	0	0	TSF mn	BFF mn	0	0	FEFm n <sup>Note</sup>	PEF mn	OVF mn

FEFm n <sup>Note</sup>	Framing error detection flag of channel n
0	No error occurs.
1	An error occurs (during UART reception).
<Clear condition> <ul style="list-style-type: none"> <li>• 1 is written to the FECTmn bit of the SIRmn register.</li> </ul> <Set condition> <ul style="list-style-type: none"> <li>• A stop bit is not detected when UART reception ends.</li> </ul>	

PEF mn	Parity error detection flag of channel n
0	No error occurs.
1	An error occurs (during UART reception) or ACK is not detected (during I <sup>2</sup> C transmission).
<Clear condition> <ul style="list-style-type: none"> <li>• 1 is written to the PECTmn bit of the SIRmn register.</li> </ul> <Set condition> <ul style="list-style-type: none"> <li>• The parity of the transmit data and the parity bit do not match when UART reception ends (parity error).</li> <li>• No ACK signal is returned from the slave channel at the ACK reception timing during I<sup>2</sup>C transmission (ACK is not detected).</li> </ul>	

OVF mn	Overrun error detection flag of channel n
0	No error occurs.
1	An error occurs
<Clear condition> <ul style="list-style-type: none"> <li>• 1 is written to the OVCTmn bit of the SIRmn register.</li> </ul> <Set condition> <ul style="list-style-type: none"> <li>• Even though receive data is stored in the SDRmn register, that data is not read and transmit data or the next receive data is written while the RXEmn bit of the SCRmn register is set to 1 (reception or transmission and reception mode in each communication mode).</li> <li>• Transmit data is not ready for slave transmission or transmission and reception in CSI mode.</li> </ul>	

**Note** The SSR01, SSR03, SSR11, and SSR13 registers only.

**Remark** m: Unit number (m = 0, 1), n: Channel number (n = 0 to 3)



**(8) Serial channel start register m (SSm)**

The SSm register is a trigger register that is used to enable starting communication/count by each channel. When 1 is written a bit of this register (SSmn), the corresponding bit (SEmn) of serial channel enable status register m (SEm) is set to 1 (Operation is enabled). Because the SSmn bit is a trigger bit, it is cleared immediately when SEmn = 1. The SSm register can be set by a 16-bit memory manipulation instruction. The lower 8 bits of the SSm register can be set with an 1-bit or 8-bit memory manipulation instruction with SSmL. Reset signal generation clears the SSm register to 0000H.

**Figure 12-12. Format of Serial Channel Start Register m (SSm)**

Address: F0122H, F0123H (SS0)    After reset: 0000H    R/W

Symbol	15	14	13	12	11	10	9	8	7	6	5	4	3	2	1	0
SS0	0	0	0	0	0	0	0	0	0	0	0	0	SS03	SS02	SS01	SS00

Address: F0162H, F0163H (SS1)    After reset: 0000H    R/W

Symbol	15	14	13	12	11	10	9	8	7	6	5	4	3	2	1	0
SS1	0	0	0	0	0	0	0	0	0	0	0	0	SS13	SS12	SS11	SS10

SSmn	Operation start trigger of channel n
0	No trigger operation
1	Sets the SEmn bit to 1 and enters the communication wait status <sup>Note</sup> .

**Note** If a communication operation is already under execution, the operation is stopped.

- Cautions**
1. Be sure to clear bits 15 to 4 of the SS0 register and bits 15 to 4 of the SS1 register to “0”.
  2. For the UART reception, set the RXEmn bit of SCRmn register to 1, and then be sure to set SSmn to 1 after 4 or more fCLK clocks have elapsed.

- Remarks**
1. m: Unit number (m = 0, 1), n: Channel number (n = 0 to 3)
  2. When the SSm register is read, 0000H is always read.

<R>

**(9) Serial channel stop register m (STm)**

The STm register is a trigger register that is used to enable stopping communication/count by each channel. When 1 is written a bit of this register (STmn), the corresponding bit (SEmn) of serial channel enable status register m (SEm) is cleared to 0 (operation is stopped). Because the STmn bit is a trigger bit, it is cleared immediately when SEmn = 0.

The STm register can set written by a 16-bit memory manipulation instruction.

The lower 8 bits of the STm register can be set with a 1-bit or 8-bit memory manipulation instruction with STmL. Reset signal generation clears the STm register to 0000H.

**Figure 12-13. Format of Serial Channel Stop Register m (STm)**

Address: F0124H, F0125H (ST0) After reset: 0000H R/W

Symbol	15	14	13	12	11	10	9	8	7	6	5	4	3	2	1	0
ST0	0	0	0	0	0	0	0	0	0	0	0	0	ST03	ST02	ST01	ST00

Address: F0164H, F0165H (ST1) After reset: 0000H R/W

Symbol	15	14	13	12	11	10	9	8	7	6	5	4	3	2	1	0
ST1	0	0	0	0	0	0	0	0	0	0	0	0	ST13	ST12	ST11	ST10

STm n	Operation stop trigger of channel n
0	No trigger operation
1	Clears the SEmn bit to 0 and stops the communication operation <sup>Note</sup> .

**Note** Communication stops while holding the value of the control register and shift register, and the status of the serial clock I/O pin, serial data output pin, and each error flag (FEFmn: framing error flag, PEFmn: parity error flag, OVFmn: overrun error flag).

**Caution** Be sure to clear bits 15 to 4 of the ST0 register and bits 15 to 4 of the ST1 register to “0”.

**Remarks** 1. m: Unit number (m = 0, 1), n: Channel number (n = 0 to 3)  
 2. When the STm register is read, 0000H is always read.

**(10)Serial channel enable status register m (SEm)**

The SEm register indicates whether data transmission/reception operation of each channel is enabled or stopped. When 1 is written a bit of serial channel start register m (SSm), the corresponding bit of this register is set to 1. When 1 is written a bit of serial channel stop register m (STm), the corresponding bit is cleared to 0. Channel n that is enabled to operate cannot rewrite by software the value of the CKOmn bit (serial clock output of channel n) of serial output register m (SOM) to be described below, and a value reflected by a communication operation is output from the serial clock pin. Channel n that stops operation can set the value of the CKOmn bit of the SOM register by software and output its value from the serial clock pin. In this way, any waveform, such as that of a start condition/stop condition, can be created by software. The SEm register can be read by a 16-bit memory manipulation instruction. The lower 8 bits of the SEm register can be set with a 1-bit or 8-bit memory manipulation instruction with SEmL. Reset signal generation clears the SEm register to 0000H.

**Figure 12-14. Format of Serial Channel Enable Status Register m (SEm)**

Address: F0120H, F0121H (SE0) After reset: 0000H R

Symbol	15	14	13	12	11	10	9	8	7	6	5	4	3	2	1	0
SE0	0	0	0	0	0	0	0	0	0	0	0	0	SE03	SE02	SE01	SE00

Address: F0160H, F0161H (SE1) After reset: 0000H R

Symbol	15	14	13	12	11	10	9	8	7	6	5	4	3	2	1	0
SE1	0	0	0	0	0	0	0	0	0	0	0	0	SE13	SE12	SE11	SE10

SEm n	Indication of operation enable/stop status of channel n															
0	Operation stops															
1	Operation is enabled.															

**Remark** m: Unit number (m = 0, 1), n: Channel number (n = 0 to 3)

**(11) Serial output enable register m (SOEm)**

The SOEm register is a register that is used to enable or stop output of the serial communication operation of each channel.

Channel n that enables serial output cannot rewrite by software the value of the SOMn bit of serial output register m (SOM) to be described below, and a value reflected by a communication operation is output from the serial data output pin.

For channel n, whose serial output is stopped, the SOMn bit value of the SOM register can be set by software, and that value can be output from the serial data output pin. In this way, any waveform of the start condition and stop condition can be created by software.

The SOEm register can be set by a 16-bit memory manipulation instruction.

The lower 8 bits of the SOEm register can be set with a 1-bit or 8-bit memory manipulation instruction with SOEmL. Reset signal generation clears the SOEm register to 0000H.

**Figure 12-15. Format of Serial Output Enable Register m (SOEm)**

Address: F012AH, F012BH After reset: 0000H R/W

Symbol	15	14	13	12	11	10	9	8	7	6	5	4	3	2	1	0
SOE0	0	0	0	0	0	0	0	0	0	0	0	0	SOE03	SOE02	SOE01	SOE00

Address: F016AH, F016BH After reset: 0000H R/W

Symbol	15	14	13	12	11	10	9	8	7	6	5	4	3	2	1	0
SOE1	0	0	0	0	0	0	0	0	0	0	0	0	SOE13	SOE12	SOE11	SOE10

SOEmn	Serial output enable/stop of channel n														
0	Stops output by serial communication operation.														
1	Enables output by serial communication operation.														

**Caution** Be sure to clear bits 15 to 4 of the SOE0 register, and bits 15 to 4 of the SOE1 register to “0”.

**Remark** m: Unit number (m = 0, 1), n: Channel number (n = 0 to 3)

**(12) Serial output register m (SOM)**

The SOM register is a buffer register for serial output of each channel.

The value of the SOMn bit of this register is output from the serial data output pin of channel n.

The value of the CKOm<sub>n</sub> bit of this register is output from the serial clock output pin of channel n.

The SOMn bit of this register can be rewritten by software only when serial output is disabled (SOEmn = 0). When serial output is enabled (SOEmn = 1), rewriting by software is ignored, and the value of the register can be changed only by a serial communication operation.

The CKOm<sub>n</sub> bit of this register can be rewritten by software only when the channel operation is stopped (SEmn = 0). While channel operation is enabled (SEmn = 1), rewriting by software is ignored, and the value of the CKOm<sub>n</sub> bit can be changed only by a serial communication operation.

To use the pin for serial interface as a port function pin, set the corresponding CKOm<sub>n</sub> and SOMn bits to “1”.

The SOM register can be set by a 16-bit memory manipulation instruction.

Reset signal generation clears the SOM register to 0F0FH.

**Figure 12-16. Format of Serial Output Register m (SOM)**

Address: F0128H, F0129H    After reset: 0F0FH    R/W

Symbol	15	14	13	12	11	10	9	8	7	6	5	4	3	2	1	0
SO0	0	0	0	0	CKO 03	CKO 02	CKO 01	CKO 00	0	0	0	0	SO 03	SO 02	SO 01	SO 00

Address: F0168H, F0169H    After reset: 0F0FH    R/W

Symbol	15	14	13	12	11	10	9	8	7	6	5	4	3	2	1	0
SO1	0	0	0	0	CKO 13	CKO 12	CKO 11	CKO 10	0	0	0	0	SO 13	SO 12	SO 11	SO 10

CKO mn	Serial clock output of channel n
0	Serial clock output value is “0”.
1	Serial clock output value is “1”.

SO mn	Serial data output of channel n
0	Serial data output value is “0”.
1	Serial data output value is “1”.

**Caution** Be sure to clear bits 15 to 12 and 7 to 4 of the SOM register to “0”.

**Remark** m: Unit number (m = 0, 1), n: Channel number (n = 0 to 3)

**(13) Serial output level register m (SOLm)**

The SOLm register is a register that is used to set inversion of the data output level of each channel.

<R> This register can be set only in the UART mode. Be sure to set 0 for corresponding bit in the CSI mode and simplifies I<sup>2</sup>C mode.

Inverting channel n by using this register is reflected on pin output only when serial output is enabled (SOEmn = 1). When serial output is disabled (SOEmn = 0), the value of the SOmn bit is output as is.

Rewriting the SOLm register is prohibited when the register is in operation (when SEMn = 1).

The SOLm register can be set by a 16-bit memory manipulation instruction.

The lower 8 bits of the SOLm register can be set with an 8-bit memory manipulation instruction with SOLmL.

Reset signal generation clears the SOLm register to 0000H.

**Figure 12-17. Format of Serial Output Level Register m (SOLm)**

Address: F0134H, F0135H (SOL0) After reset: 0000H R/W

Symbol	15	14	13	12	11	10	9	8	7	6	5	4	3	2	1	0
SOL0	0	0	0	0	0	0	0	0	0	0	0	0	0	SOL 02	0	SOL 00

Address: F0174H, F0175H (SOL1) After reset: 0000H R/W

Symbol	15	14	13	12	11	10	9	8	7	6	5	4	3	2	1	0
SOL1	0	0	0	0	0	0	0	0	0	0	0	0	0	SOL 12	0	SOL 10

SOL mn	Selects inversion of the level of the transmit data of channel n in UART mode
0	Communication data is output as is.
1	Communication data is inverted and output.

**Caution** Be sure to clear bits 15 to 3, and 1 of the SOL0 register and bits 15 to 3, and 1 of the SOL1 register to “0”.

**Remark** m: Unit number (m = 0, 1), n: Channel number (n = 0, 2)

**(14) Serial standby control register m (SSCm)**

The SSC0 register is used to control the startup of reception (the SNOOZE mode) while in the STOP mode when receiving CSI00 or UART0 serial data.

The SSC1<sup>Note</sup> register is used to control the startup of reception (the SNOOZE mode) while in the STOP mode when receiving CSI20 or UART2 serial data.

The SSCm register can be set by a 16-bit memory manipulation instruction.

The lower 8 bits of the SSCm register can be set with an 8-bit memory manipulation instruction with SSCmL.

Reset signal generation clears the SSCm register to 0000H.

<R> **Note** The SSC1 register is provided in the 80, 100, 128-pin products only.

**Caution** The maximum transfer rate in the SNOOZE mode is as follows.

- When using CSI00, CSI20 : 1 Mbps (target)
- When using UART0, UART2 : 9600 bps (target)

**Figure 12-18. Format of Serial Standby Control Register m (SSCm)**

Address: F0138H (SSC0), F0178H (SSC1) After reset: 0000H R/W

Symbol	15	14	13	12	11	10	9	8	7	6	5	4	3	2	1	0
SSCm	0	0	0	0	0	0	0	0	0	0	0	0	0	0	SS ECm	SWC m

SS ECm	Selection of whether to enable or stop the generation of transfer end interrupts
0	Enable the generation of error interrupts (INTSRE0/INTSRE2). In the following cases, the clock request signal (an internal signal) to the clock generator is also cleared: <ul style="list-style-type: none"> <li>• When the SWC bit is cleared to 0</li> <li>• When the UART reception start bit is mistakenly detected</li> </ul>
1	Stop the generation of error interrupts (INTSRE0/INTSRE2). In the following cases, the clock request signal (an internal signal) to the clock generator is also cleared: <ul style="list-style-type: none"> <li>• When the SWCm bit is cleared to 0</li> <li>• When the UART reception start bit is mistakenly detected</li> <li>• When the transfer end interrupt generation timing is based on a parity error or framing error</li> </ul>

SW Cm	Selection of whether to enable or stop the startup of CSI00/CSI20 or UART0/UART2 reception while in the STOP mode
0	Stop the startup of reception while in the STOP mode.
1	Enable the startup of reception while in the STOP mode. (During asynchronous CSI00/CSI20 reception or UART0/UART2 reception, the baud rate adjustment function is enabled.)

<R> **Caution** Setting SSECm, SWCm = 1, 0 is prohibited.

**(15) Input switch control register (ISC)**

The ISC1 and ISC0 bits of the ISC register are used to realize a LIN-bus communication operation by UART2 in coordination with an external interrupt and the timer array unit.

When bit 0 is set to 1, the input signal of the serial data input (RxD2) pin is selected as an external interrupt (INTP0) that can be used to detect a wakeup signal.

When bit 1 is set to 1, the input signal of the serial data input (RxD2) pin is selected as a timer input, so that wake up signal can be detected, the low width of the sync break field, and the pulse width of the sync field can be measured by the timer.

The ISC register can be set by a 1-bit or 8-bit memory manipulation instruction.

Reset signal generation clears the ISC register to 00H.

**Figure 12-19. Format of Input Switch Control Register (ISC)**

Address: F0073H    After reset: 00H    R/W

Symbol	7	6	5	4	3	2	1	0
ISC	0	0	0	0	0	0	ISC1	ISC0

ISC1	Switching channel 7 input of timer array unit
0	30, 32, 36, 40, 44, 48, 52, 64, 80, 100, and 128-pin products: Uses the input signal of the TI07 pin as a timer input (normal operation). 20, 24, and 25-pin products: Do not use a timer input signal for channel 7.
1	Input signal of the RxD2 pin is used as timer input (detects the wakeup signal and measures the low width of the sync break field and the pulse width of the sync field). Setting is prohibited in the 20, 24, and 25-pin products.

ISC0	Switching external interrupt (INTP0) input
0	Uses the input signal of the INTP0 pin as an external interrupt (normal operation).
1	Uses the input signal of the RxD2 pin as an external interrupt (wakeup signal detection).

**Caution** Be sure to clear bits 7 to 2 to “0”.



**(16) Noise filter enable register 0 (NFEN0)**

The NFEN0 register is used to set whether the noise filter can be used for the input signal from the serial data input pin to each channel.

Disable the noise filter of the pin used for CSI or simplified I<sup>2</sup>C communication, by clearing the corresponding bit of this register to 0.

Enable the noise filter of the pin used for UART communication, by setting the corresponding bit of this register to 1.

When the noise filter is enabled, CPU/peripheral hardware clock (f<sub>CLK</sub>) is synchronized with 2-clock match detection. When the noise filter is OFF, only synchronization is performed with the CPU/peripheral hardware clock (f<sub>MCK</sub>)<sup>Note</sup>.

The NFEN0 register can be set by a 1-bit or 8-bit memory manipulation instruction.

Reset signal generation clears the NFEN0 register to 00H.

**Note** For details, see 6.5.1 (2) When valid edge of input signal input from the TI0n pin is selected (CCS0n = 1) and 6.5.2 Start timing of counter.

**Figure 12-20. Format of Noise Filter Enable Register 0 (NFEN0)**

Address: F0070H    After reset: 00H    R/W

Symbol	7	6	5	4	3	2	1	0
NFEN0	0	SNFEN30	0	SNFEN20	0	SNFEN10	0	SNFEN00

SNFEN30	Use of noise filter of RxD2 pin (RxD2/SDA20/SI20/P14)
0	Noise filter OFF
1	Noise filter ON
Set SNFEN30 to 1 to use the RxD3 pin. Clear SNFEN30 to 0 to use the other than RxD3 pin.	

SNFEN20	Use of noise filter of RxD2 pin (RxD2/SDA20/SI20/P14)
0	Noise filter OFF
1	Noise filter ON
Set SNFEN20 to 1 to use the RxD2 pin. Clear SNFEN20 to 0 to use the other than RxD2 pin.	

SNFEN10	Use of noise filter of RxD1 pin (RXD1/ANI16/SI10/SDA10/P03)
0	Noise filter OFF
1	Noise filter ON
Set the SNFEN10 bit to 1 to use the RxD1 pin. Clear the SNFEN10 bit to 0 to use the other than RxD1 pin.	

SNFEN00	Use of noise filter of RxD0 pin (RXD0/TOOLRXD/SDA00/SI00/P11)
0	Noise filter OFF
1	Noise filter ON
Set the SNFEN00 bit to 1 to use the RxD0 pin. Clear the SNFEN00 bit to 0 to use the other than RxD0 pin.	

**Caution** Be sure to clear bits 7, 5, 3, and 1 to “0”.

**(17) Port input mode registers 0, 1, 4, 5, 8, 14 (PIM0, PIM1, PIM4, PIM5, PIM8, PIM14)**

These registers set the input buffer of ports 0, 1, 4, 5, 8, and 14 in 1-bit units.

The PIM0, PIM1, PIM4, PIM5, PIM8, and PIM14 registers can be set by a 1-bit or 8-bit memory manipulation instruction.

Reset signal generation clears the PIM0, PIM1, PIM4, PIM5, PIM8 and PIM14 registers to 00H.

**Figure 12-21. Format of Port Input Mode Registers 0, 1, 4, 5, 8 and 14 (PIM0, PIM1, PIM4, PIM5, PIM8, PIM14)**

Address F0040H    After reset: 00H    R/W

Symbol	7	6	5	4	3	2	1	0
PIM0	0	0	0	PIM04	PIM03	0	PIM01	0

Address F0041H    After reset: 00H    R/W

Symbol	7	6	5	4	3	2	1	0
PIM1	PIM17	PIM16	PIM15	PIM14	PIM13	0	PIM11	PIM10

Address F0044H    After reset: 00H    R/W

Symbol	7	6	5	4	3	2	1	0
PIM4	0	0	0	PIM44	PIM43	0	0	0

Address F0045H    After reset: 00H    R/W

Symbol	7	6	5	4	3	2	1	0
PIM5	0	0	PIM55	PIM54	PIM53	0	0	0

Address F0048H    After reset: 00H    R/W

Symbol	7	6	5	4	3	2	1	0
PIM8	0	0	0	0	0	0	PIM81	PIM80

Address F004EH    After reset: 00H    R/W

Symbol	7	6	5	4	3	2	1	0
PIM14	0	0	0	0	PIM143	PIM142	0	0

PIMmn	Pmn pin input buffer selection (m = 0, 1, 4, 5, 8, 14; n = 0 to 7)
0	Normal input buffer
1	TTL input buffer

**(18) Port output mode registers 0, 1, 4, 5, 7 to 9, 14 (POM0, POM1, POM4, POM5, POM7 to POM9, POM14)**

These registers set the output mode of ports 0, 1, 4, 5, 7 to 9, and 14 in 1-bit units.

The POM0, POM1, POM4, POM5, POM7 to POM9, and POM14 registers can be set by a 1-bit or 8-bit memory manipulation instruction.

Reset signal generation clears the POM0, POM1, POM4, POM5, POM7 to POM9, and POM14 registers to 00H.

**Figure 12-22. Format of Port Output Mode Registers 0, 1, 4, 5, 7 to 9, and 14 (POM0, POM1, POM4, POM5, POM7 to POM9, POM14) (128-pin products)**

Address F0050H    After reset: 00H    R/W

Symbol	7	6	5	4	3	2	1	0
POM0	0	0	0	POM04	POM03	POM02	0	POM00

Address F0051H    After reset: 00H    R/W

Symbol	7	6	5	4	3	2	1	0
POM1	POM17	0	POM15	POM14	POM13	POM12	POM11	POM10

Address F0054H    After reset: 00H    R/W

Symbol	7	6	5	4	3	2	1	0
POM4	0	0	POM45	POM44	POM43	0	0	0

Address F0055H    After reset: 00H    R/W

Symbol	7	6	5	4	3	2	1	0
POM5	0	0	POM	POM54	POM53	POM52	0	POM50

Address F0057H    After reset: 00H    R/W

Symbol	7	6	5	4	3	2	1	0
POM7	0	0	0	POM74	0	0	POM71	0

Address F0058H    After reset: 00H    R/W

Symbol	7	6	5	4	3	2	1	0
POM8	0	0	0	0	0	POM82	POM81	POM 80

Address F0059H    After reset: 00H    R/W

Symbol	7	6	5	4	3	2	1	0
POM9	0	POM 96	0	0	0	0	0	0

Address F005EH    After reset: 00H    R/W

Symbol	7	6	5	4	3	2	1	0
POM14	0	0	0	POM144	POM 143	POM142	0	0

POMmn	Pmn pin output buffer selection (m = 0, 1, 4, 5, 7 to 9, 14; n = 0 to 7)
0	Normal output mode
1	N-ch open-drain output (V <sub>DD</sub> tolerance) mode

**(19) Port mode registers 0, 1, 3 to 5, 7 to 9, and 14 (PM0, PM1, PM3 to PM5, PM7 to PM9, and PM14)**

These registers set input/output of ports 0, 1, 3 to 5, 7 to 9, and 14 in 1-bit units.

When using the ports (such as P02/ANI17/SO10/TXD1, P04/ $\overline{\text{SCK10}}$ /SCL10) to be shared with the serial data output pin or serial clock output pin for serial data output or serial clock output, set the port mode register (PMxx) bit corresponding to each port to 0. And set the port register (Pxx) bit corresponding to each port to 1

Example: When using P02/ANI17/SO10/TXD1 for serial data output

Set the PM02 bit of the port mode register 0 to 0.

Set the P02 bit of the port register 0 to 1.

When using the ports (such as P04/ $\overline{\text{SCK10}}$ /SCL10, P50/INTP1/SI11/SDA11) to be shared with the serial data input pin or serial clock input pin for serial data input or serial clock input, set the port mode register (PMxx) bit corresponding to each port to 1. At this time, the port register (Pxx) bit may be 0 or 1.

Example: When using P50/INTP1/SI11/SDA11 for serial data input

Set the PM50 bit of port mode register 5 to 1.

Set the P50 bit of port register 5 to 0 or 1.

The PM0, PM1, PM3 to PM5, PM7 to PM9, and PM14 registers can be set by a 1-bit or 8-bit memory manipulation instruction.

Reset signal generation sets the PM0, PM1, PM3 to PM5, PM7 to PM9, and PM14 registers to FFH.

**Figure 12-23. Format of Port Mode Registers 0, 1, 3 to 5, 7 to 9, and 14 (PM0, PM1, PM3 to PM5, PM7 to PM9, and 14)**

Address: FFF20H After reset: FFH R/W

Symbol	7	6	5	4	3	2	1	0
PM0	1	PM06	PM05	PM04	PM03	PM02	PM01	PM00

Address: FFF21H After reset: FFH R/W

Symbol	7	6	5	4	3	2	1	0
PM1	PM17	PM16	PM15	PM14	PM13	PM12	PM11	PM10

Address: FFF23H After reset: FFH R/W

Symbol	7	6	5	4	3	2	1	0
PM3	1	1	1	1	1	1	PM31	PM30

Address: FFF24H After reset: FFH R/W

Symbol	7	6	5	4	3	2	1	0
PM4	PM47	PM46	PM45	PM44	PM43	PM42	PM41	PM40

Address: FFF25H After reset: FFH R/W

Symbol	7	6	5	4	3	2	1	0
PM5	1	1	PM55	PM54	PM53	PM52	PM51	PM50

Address: FFF27H After reset: FFH R/W

Symbol	7	6	5	4	3	2	1	0
PM7	PM77	PM76	PM75	PM74	PM73	PM72	PM71	PM70

Address: FFF28H After reset: FFH R/W

Symbol	7	6	5	4	3	2	1	0
PM8	PM87	PM86	PM85	PM84	PM83	PM82	PM81	PM80

Address: FFF29H After reset: FFH R/W

Symbol	7	6	5	4	3	2	1	0
PM9	PM97	PM96	PM95	PM94	PM93	PM92	PM91	PM90

Address: FFF2EH After reset: FFH R/W

Symbol	7	6	5	4	3	2	1	0
PM14	PM147	PM146	PM145	PM144	PM143	PM142	PM141	PM140

PMmn	Pmn pin I/O mode selection (m = 0, 1, 3 to 5, 7 to 9, 14; n = 0 to 7)
0	Output mode (output buffer on)
1	Input mode (output buffer off)

## 12.4 Operation stop mode

Each serial interface of serial array unit has the operation stop mode.

In this mode, serial communication cannot be executed, thus reducing the power consumption.

In addition, the pin for serial interface can be used as port function pins in this mode.

### 12.4.1 Stopping the operation by units

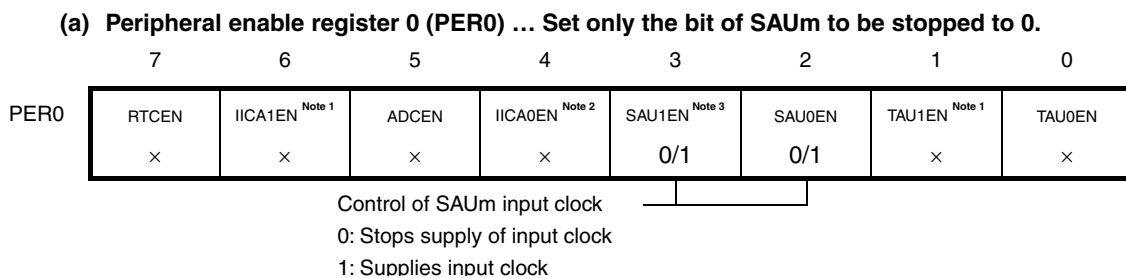
The stopping of the operation by units is set by using peripheral enable register 0 (PER0).

The PER0 register is used to enable or disable supplying the clock to the peripheral hardware. Clock supply to a hardware macro that is not used is stopped in order to reduce the power consumption and noise.

To stop the operation of serial array unit 0, set bit 2 (SAU0EN) to 0.

To stop the operation of serial array unit 1, set bit 3 (SAU1EN) to 0.

**Figure 12-24. Peripheral Enable Register 0 (PER0) Setting When Stopping the Operation by Units**



**Notes 1.** 80, 100, and 128-pin products only.

**2.** This is not provided in the 20-pin products.

**3.** This is not provided in the 20, 24, and 25-pin products.

**Cautions 1.** If SAUmEN = 0, writing to a control register of serial array unit m is ignored, and, even if the register is read, only the default value is read

Note that this does not apply to the following registers.

- Input switch control register (ISC)
- Noise filter enable register 0 (NFEN0)
- Serial standby control register 0 (SSC0)
- Port input mode registers 0, 1, 4, 5, 8, 14 (PIM0, PIM1, PIM4, PIM5, PIM8, PIM14)
- Port output mode registers 0, 1, 4, 5, 7 to 9, 14 (POM0, POM1, POM4, POM5, POM7 to POM9, POM14)
- Port mode registers 0, 1, 3 to 5, 7 to 9, 14 (PM0, PM1, PM3 to PM5, PM7 to PM9, PM14)
- Port registers 0, 1, 3 to 5, 7 to 9, 14 (P0, P1, P3 to P5, P7 to P9, P14)

**2.** Be sure to clear the following bits to 0.

20-pin products: bits 1, 3, 4, 6

24, 25-pin products: bits 1, 3, 6

30, 32, 36, 40, 44, 48, 52, 64-pin products: bits 1, 6

**Remark** ×: Bits not used with serial array units (depending on the settings of other peripheral functions)

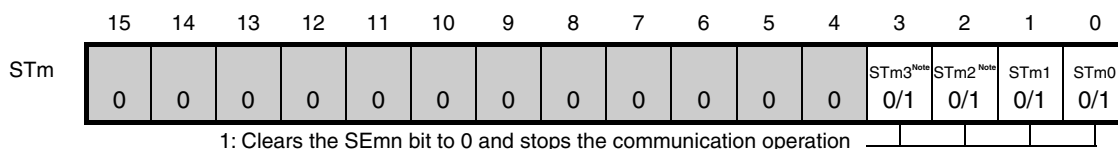
0/1: Set to 0 or 1 depending on the usage of the user

12.4.2 Stopping the operation by channels

The stopping of the operation by channels is set using each of the following registers.

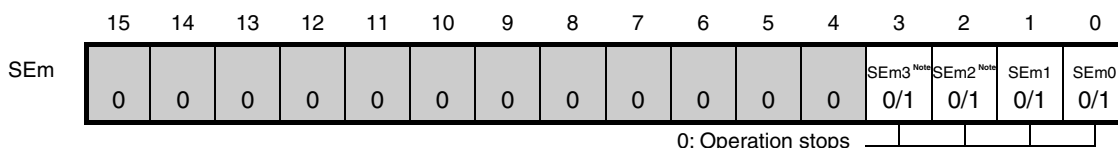
Figure 12-25. Each Register Setting When Stopping the Operation by Channels

(a) **Serial channel stop register m (STm) ... This register is a trigger register that is used to enable stopping communication/count by each channel.**



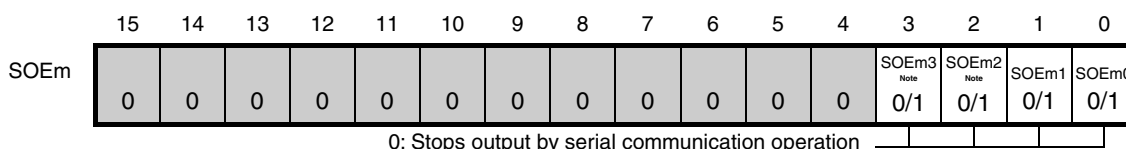
\* Because the ST<sub>m</sub>n bit is a trigger bit, it is cleared immediately when SE<sub>m</sub>n = 0.

(b) **Serial Channel Enable Status Register m (SEm) ... This register indicates whether data transmission/reception operation of each channel is enabled or stopped.**



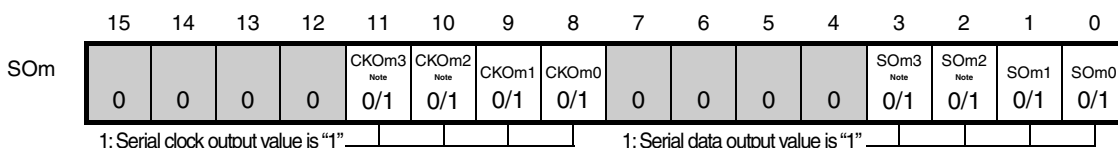
\* The SEm register is a read-only status register, whose operation is stopped by using the STm register. With a channel whose operation is stopped, the value of the CKOm<sub>n</sub> bit of the SOm register can be set by software.

(c) **Serial output enable register m (SOEm) ... This register is a register that is used to enable or stop output of the serial communication operation of each channel.**



\* For channel n, whose serial output is stopped, the SOm<sub>n</sub> bit value of the SOm register can be set by software.

(d) **Serial output register m (SOm) ... This register is a buffer register for serial output of each channel.**



\* When using pins corresponding to each channel as port function pins, set the corresponding CKOm<sub>n</sub>, SOm<sub>n</sub> bits to "1".

**Note** Serial array unit 0 only.

- Remarks 1.** m: Unit number (m = 0, 1), n: Channel number (n = 0 to 3)  
 2. : Setting disabled (fixed by hardware), 0/1: Set to 0 or 1 depending on the usage of the user



## 12.5 Operation of 3-Wire Serial I/O (CSI00, CSI01, CSI10, CSI11, CSI20, CSI21, CSI30, CSI31) Communication

This is a clocked communication function that uses three lines: serial clock ( $\overline{\text{SCK}}$ ) and serial data (SI and SO) lines.

[Data transmission/reception]

- Data length of 7 or 8 bits
- Phase control of transmit/receive data
- MSB/LSB first selectable
- Level setting of transmit/receive data

[Clock control]

- Master/slave selection
- Phase control of I/O clock
- Setting of transfer period by prescaler and internal counter of each channel
- Maximum transfer rate

During master communication (CSI00): Max.  $f_{\text{CLK}}/2$  <sup>Note</sup>

During master communication (other than CSI00): Max.  $f_{\text{CLK}}/4$  <sup>Note</sup>

During slave communication: Max.  $f_{\text{MCK}}/6$  <sup>Note</sup>

[Interrupt function]

- Transfer end interrupt/buffer empty interrupt

[Error detection flag]

- Overrun error

In addition, CSIs of following channels supports the SNOOZE mode. When  $\overline{\text{SCK}}$  input is detected while in the STOP mode, the SNOOZE mode makes data reception that does not require the CPU possible. Only following CSIs can be specified for asynchronous reception.

- <R>
- 24 to 64-pin products: CSI00 only
  - 80, 100, 128-pin products: CSI00 and CSI20 only

**Note** Use the clocks within a range satisfying the  $\overline{\text{SCK}}$  cycle time ( $t_{\text{CKCY}}$ ) characteristics (see **CHAPTER 29 ELECTRICAL SPECIFICATIONS**).

The channels supporting 3-wire serial I/O (CSI00, CSI01, CSI10, CSI11, CSI20, CSI21, CSI30, CSI31) are channels 0 to 3 of SAU0 and channels 0 to 3 of SAU1.

- 20, 24, 25-pin products

Unit	Channel	Used as CSI	Used as UART	Used as Simplified I <sup>2</sup> C
0	0	CSI00	UART0	IIC00
	1	–		–
	2	–	UART1	–
	3	CSI11		IIC11
1	0	–	–	–
	1	–	–	–

- 30, 32-pin products

Unit	Channel	Used as CSI	Used as UART	Used as Simplified I <sup>2</sup> C
0	0	CSI00	UART0	IIC00
	1	–		–
	2	–	UART1	–
	3	CSI11		IIC11
1	0	CSI20	UART2 (supporting LIN-bus)	IIC20
	1	–		–

- 36, 40, 44-pin products

Unit	Channel	Used as CSI	Used as UART	Used as Simplified I <sup>2</sup> C
0	0	CSI00	UART0	IIC00
	1	–		–
	2	–	UART1	–
	3	CSI11		IIC11
1	0	CSI20	UART2 (supporting LIN-bus)	IIC20
	1	CSI21		IIC21

- 48, 52-pin products

Unit	Channel	Used as CSI	Used as UART	Used as Simplified I <sup>2</sup> C
0	0	CSI00	UART0	IIC00
	1	CSI01		IIC01
	2	–	UART1	–
	3	CSI11		IIC11
1	0	CSI20	UART2 (supporting LIN-bus)	IIC20
	1	CSI21		IIC21

- 64-pin products

Unit	Channel	Used as CSI	Used as UART	Used as Simplified I <sup>2</sup> C
0	0	CSI00	UART0	IIC00
	1	CSI01		IIC01
	2	CSI10	UART1	IIC10
	3	CSI11		IIC11
1	0	CSI20	UART2 (supporting LIN-bus)	IIC20
	1	CSI21		IIC21

- 80, 100, 128-pin products

Unit	Channel	Used as CSI	Used as UART	Used as Simplified I <sup>2</sup> C
0	0	CSI00	UART0	IIC00
	1	CSI01		IIC01
	2	CSI10	UART1	IIC10
	3	CSI11		IIC11
1	0	CSI20	UART2 (supporting LIN-bus)	IIC20
	1	CSI21		IIC21
	2	CSI30	UART3	IIC30
	3	CSI31		IIC31

3-wire serial I/O (CSI00, CSI01, CSI10, CSI11, CSI20, CSI21, CSI30, CSI31) performs the following seven types of communication operations.

- Master transmission (See 12.5.1.)
- Master reception (See 12.5.2.)
- Master transmission/reception (See 12.5.3.)
- Slave transmission (See 12.5.4.)
- Slave reception (See 12.5.5.)
- Slave transmission/reception (See 12.5.6.)
- SNOOZE mode function (See 12.5.7.)

### 12.5.1 Master transmission

Master transmission is that the RL78/G13 outputs a transfer clock and transmits data to another device.

3-Wire Serial I/O	CSI00	CSI01	CSI10	CSI11	CSI20	CSI21	CSI30	CSI31
Target channel	Channel 0 of SAU0	Channel 1 of SAU0	Channel 2 of SAU0	Channel 3 of SAU0	Channel 0 of SAU1	Channel 1 of SAU1	Channel 2 of SAU1	Channel 3 of SAU1
Pins used	$\overline{\text{SCK00}}$ , SO00	$\overline{\text{SCK01}}$ , SO01	$\overline{\text{SCK10}}$ , SO10	$\overline{\text{SCK11}}$ , SO11	$\overline{\text{SCK20}}$ , SO20	$\overline{\text{SCK21}}$ , SO21	$\overline{\text{SCK30}}$ , SO30	$\overline{\text{SCK31}}$ , SO31
Interrupt	INTCSI00	INTCSI01	INTCSI10	INTCSI11	INTCSI20	INTCSI21	INTCSI30	INTCSI31
	Transfer end interrupt (in single-transfer mode) or buffer empty interrupt (in continuous transfer mode) can be selected.							
Error detection flag	None							
Transfer data length	7 or 8 bits							
Transfer rate	Max. $f_{\text{CLK}}/2$ [Hz] (CSI00), $f_{\text{CLK}}/4$ [Hz] (other than CSI00) Min. $f_{\text{CLK}}/(2 \times 2^{15} \times 128)$ [Hz] <sup>Note</sup> $f_{\text{CLK}}$ : System clock frequency							
Data phase	Selectable by the DAPmn bit of the SCRmn register <ul style="list-style-type: none"> <li>DAPmn = 0: Data output starts from the start of the operation of the serial clock.</li> <li>DAPmn = 1: Data output starts half a clock before the start of the serial clock operation.</li> </ul>							
Clock phase	Selectable by the CKPmn bit of the SCRmn register <ul style="list-style-type: none"> <li>CKPmn = 0: Forward</li> <li>CKPmn = 1: Reverse</li> </ul>							
Data direction	MSB or LSB first							

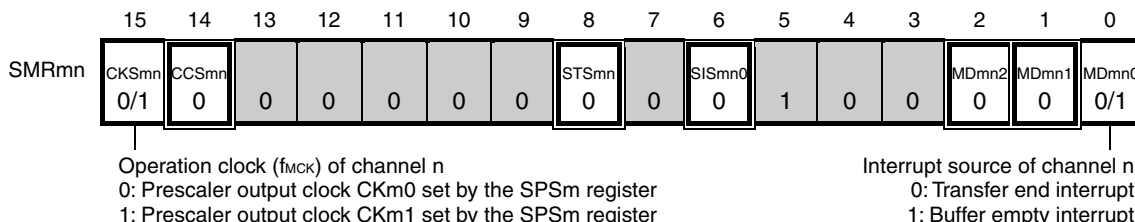
**Note** Use this operation within a range that satisfies the conditions above and the AC characteristics in the electrical specifications (see **CHAPTER 29 ELECTRICAL SPECIFICATIONS**).

**Remark** m: Unit number (m = 0, 1), n: Channel number (n = 0 to 3), mn = 00 to 03, 10 to 13

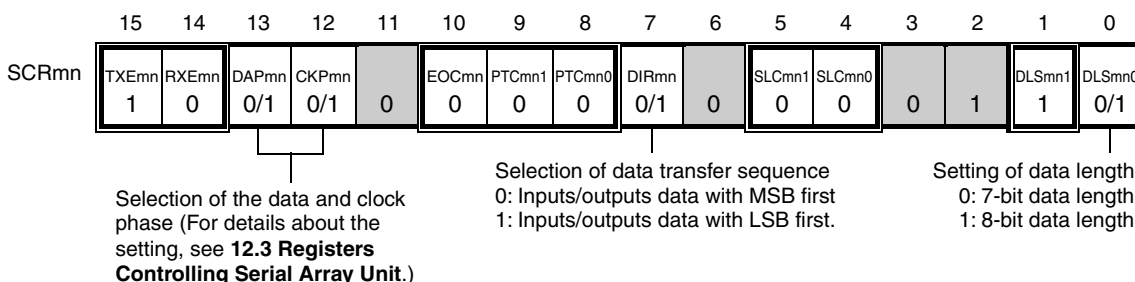
(1) Register setting

Figure 12-26. Example of Contents of Registers for Master Transmission of 3-Wire Serial I/O (CSI00, CSI01, CSI10, CSI11, CSI20, CSI21, CSI30, CSI31) (1/2)

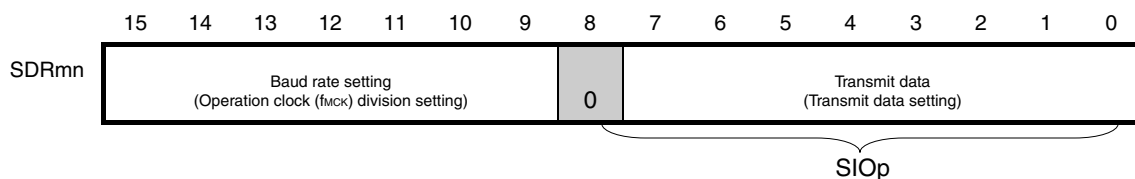
(a) Serial mode register mn (SMRmn)



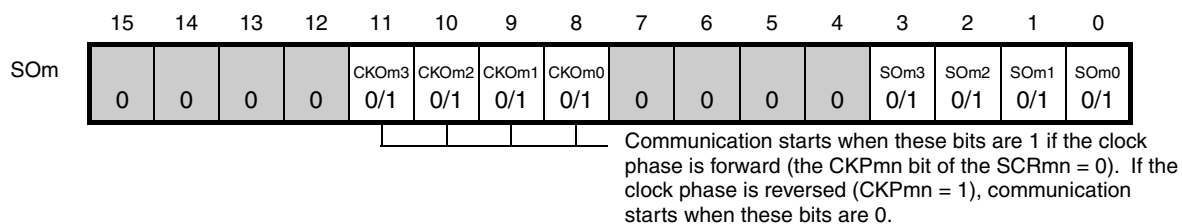
(b) Serial communication operation setting register mn (SCRmn)



(c) Serial data register mn (SDRmn) (lower 8 bits: SIOp)



(d) Serial output register m (SOM) ... Sets only the bits of the target channel.



- Remarks 1.** m: Unit number (m = 0, 1), n: Channel number (n = 0 to 3), p: CSI number (p = 00, 01, 10, 11, 20, 21, 30, 31), mn = 00 to 03, 10 to 13
- 2.** □: Setting is fixed in the CSI master transmission mode, ■: Setting disabled (set to the initial value)  
 0/1: Set to 0 or 1 depending on the usage of the user

**Figure 12-26. Example of Contents of Registers for Master Transmission of 3-Wire Serial I/O (CSI00, CSI01, CSI10, CSI11, CSI20, CSI21) (2/2)**

**(e) Serial output enable register m (SOEm) ... Sets only the bits of the target channel to 1.**

	15	14	13	12	11	10	9	8	7	6	5	4	3	2	1	0
SOEm	0	0	0	0	0	0	0	0	0	0	0	0	SOEm3 0/1	SOEm2 0/1	SOEm1 0/1	SOEm0 0/1

**(f) Serial channel start register m (SSm) ... Sets only the bits of the target channel to 1.**

	15	14	13	12	11	10	9	8	7	6	5	4	3	2	1	0
SSm	0	0	0	0	0	0	0	0	0	0	0	0	SSm3 0/1	SSm2 0/1	SSm1 0/1	SSm0 0/1

**Remarks 1.** m: Unit number (m = 0, 1), n: Channel number (n = 0 to 3), p: CSI number (p = 00, 01, 10, 11, 20, 21, 30, 31), mn = 00 to 03, 10 to 13

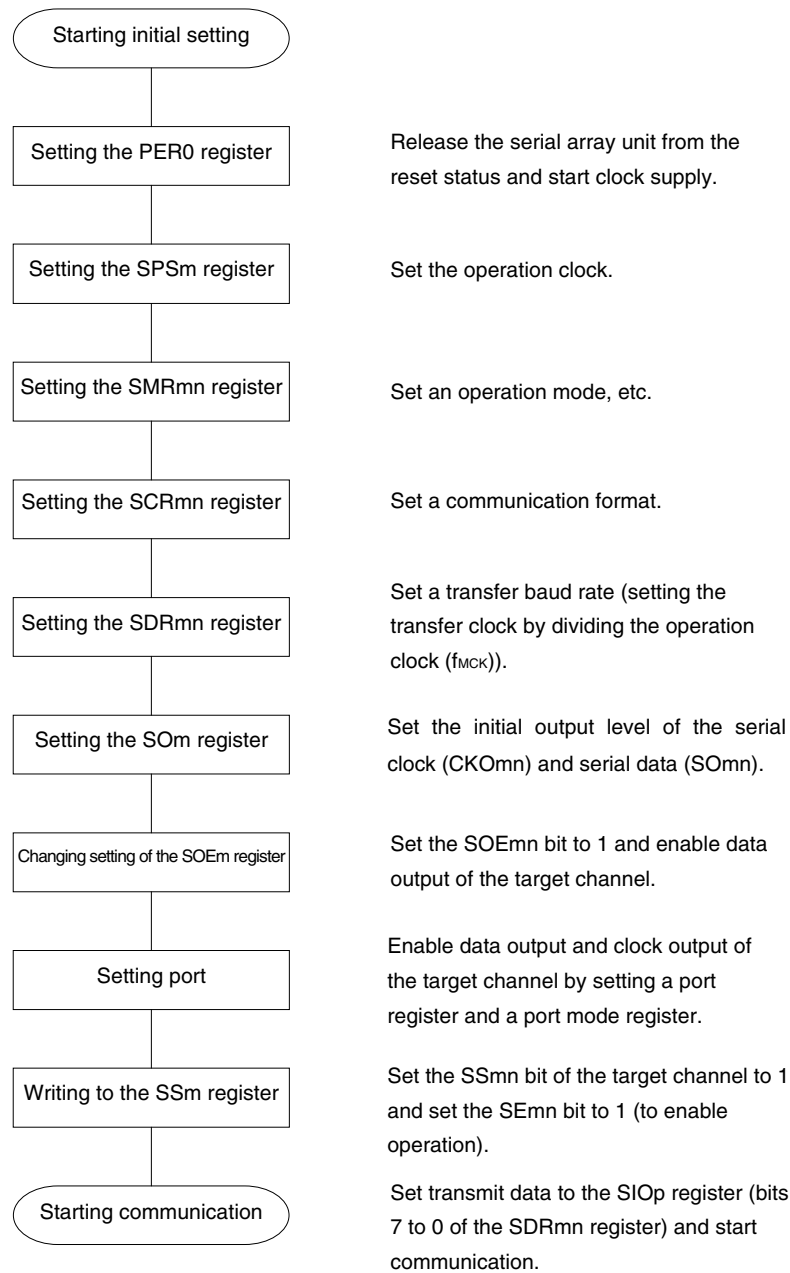
**2.** □: Setting disabled (set to the initial value)

×: Bit that cannot be used in this mode (set to the initial value when not used in any mode)

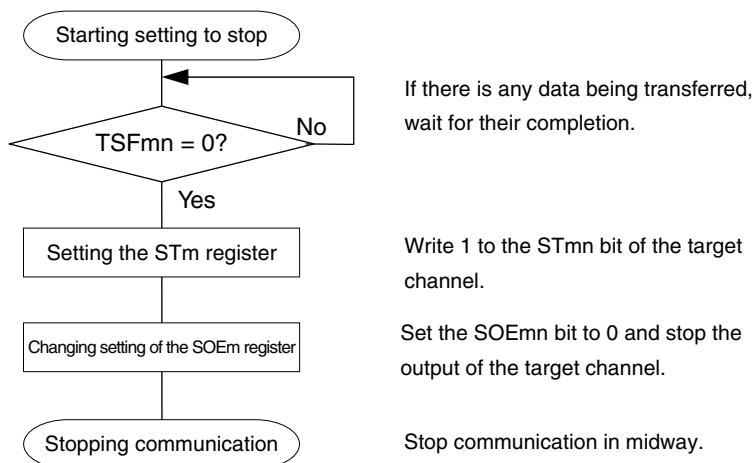
0/1: Set to 0 or 1 depending on the usage of the user

## (2) Operation procedure

Figure 12-27. Initial Setting Procedure for Master Transmission

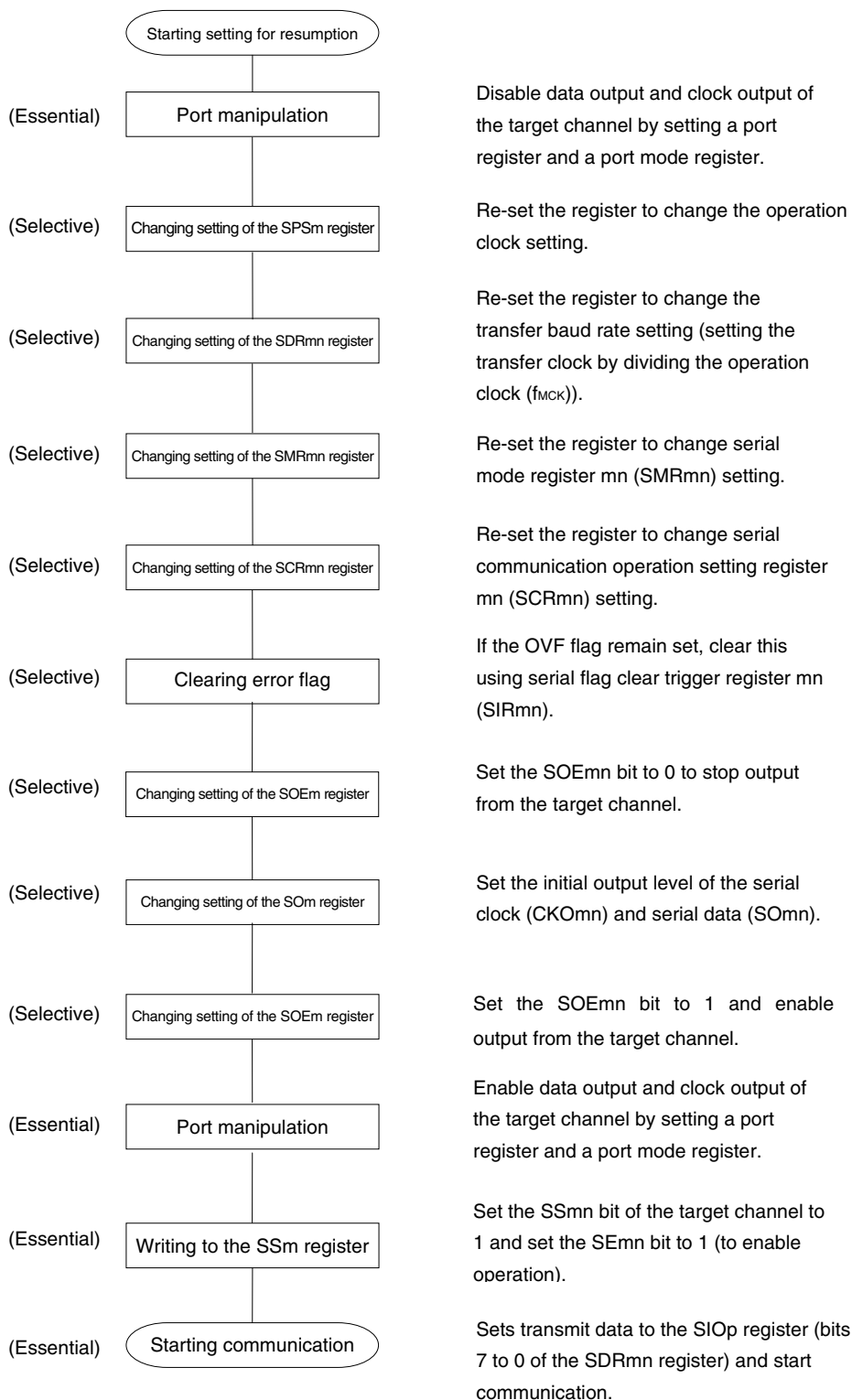


**Figure 12-28. Procedure for Stopping Master Transmission**



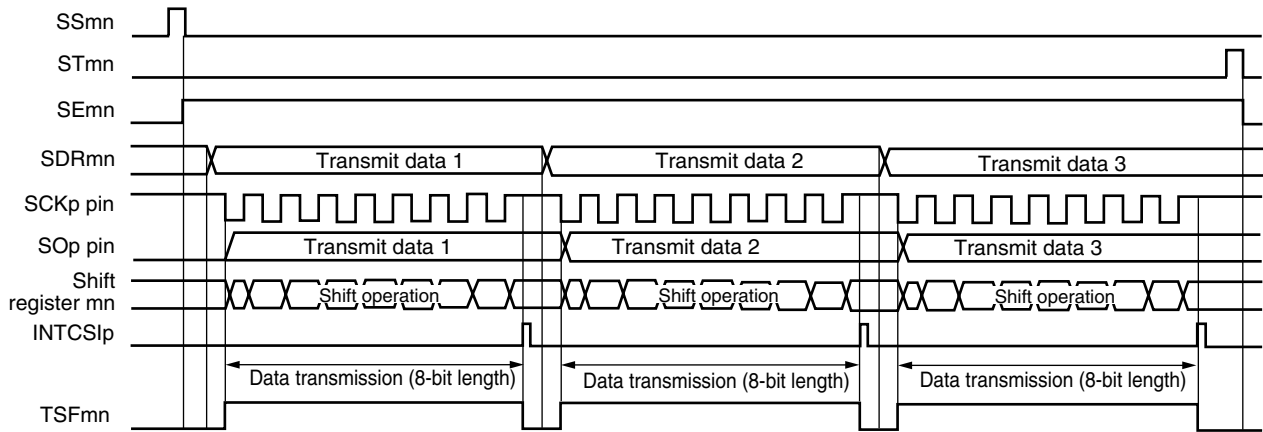


**Figure 12-29. Procedure for Resuming Master Transmission**



(3) Processing flow (in single-transmission mode)

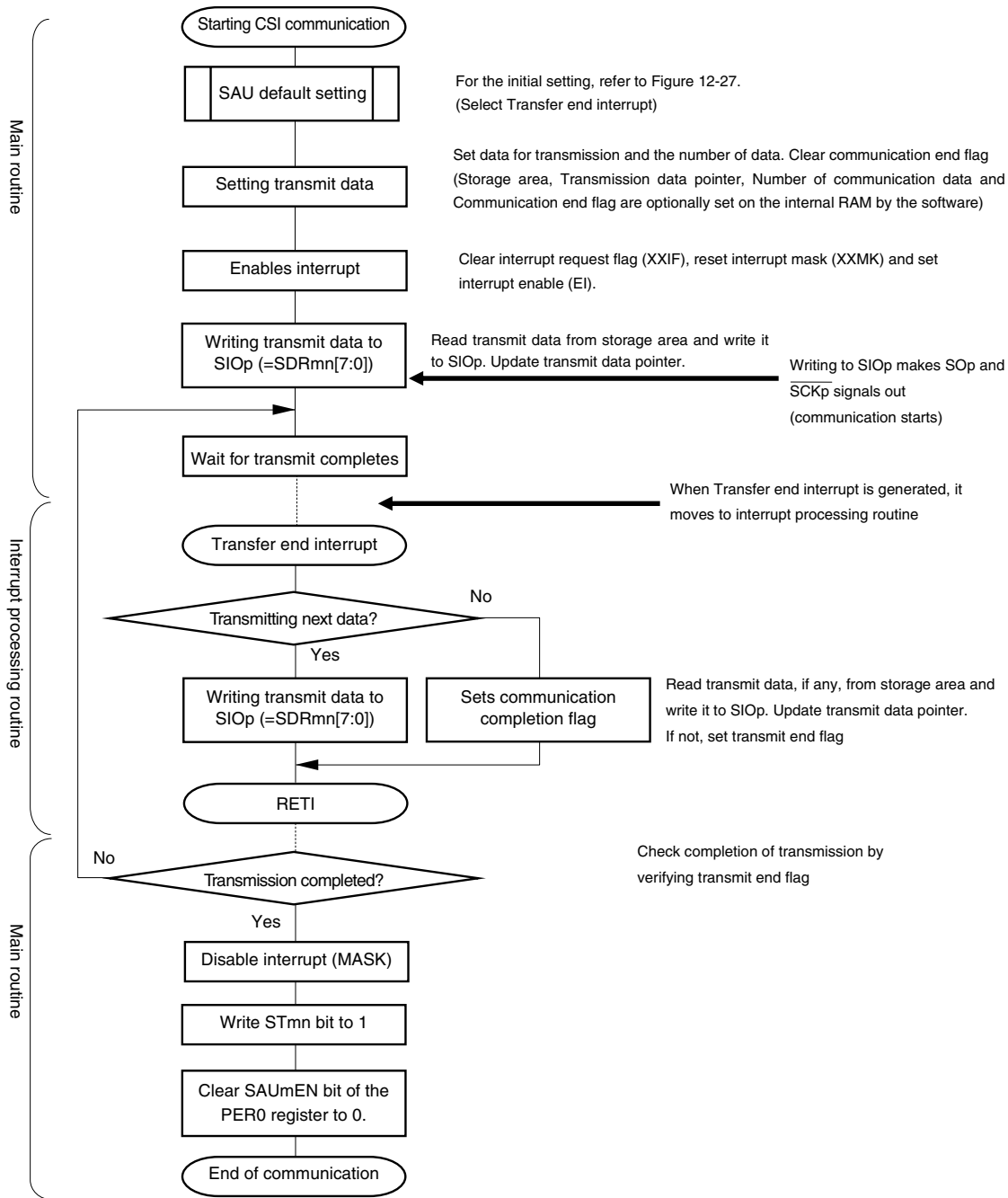
**Figure 12-30. Timing Chart of Master Transmission (in Single-Transmission Mode)**  
 (Type 1: DAPmn = 0, CKPmn = 0)



**Remark** m: Unit number (m = 0, 1), n: Channel number (n = 0 to 3), p: CSI number (p = 00, 01, 10, 11, 20, 21, 30, 31), mn = 00 to 03, 10 to 13

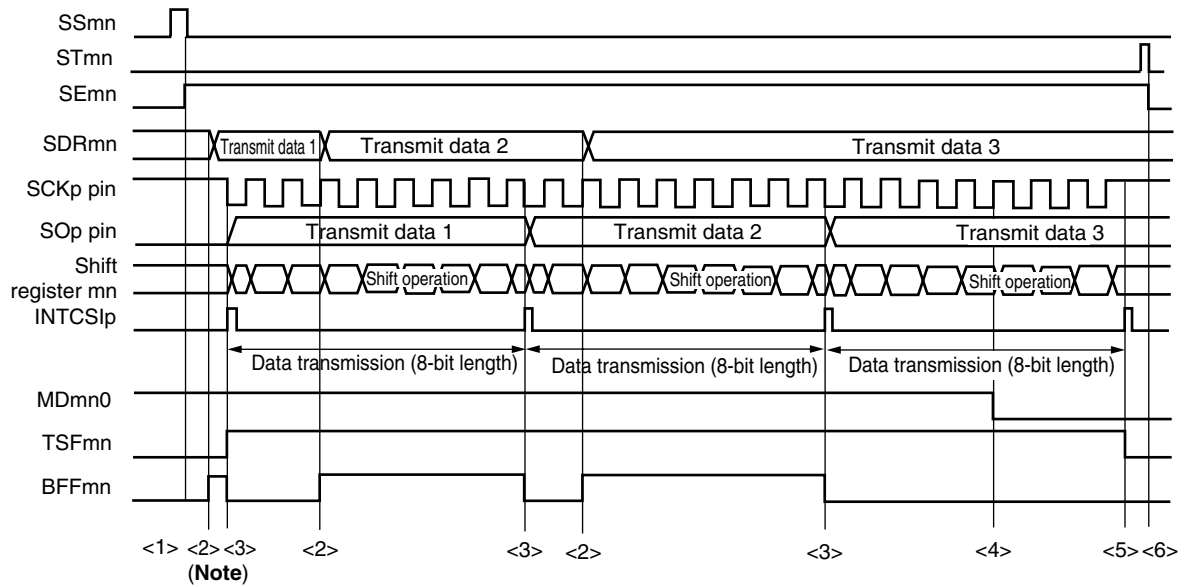
<R>

Figure 12-31. Flowchart of Master Transmission (in Single-Transmission Mode)



(4) Processing flow (in continuous transmission mode)

**Figure 12-32. Timing Chart of Master Transmission (in Continuous Transmission Mode)**  
 (Type 1: DAPmn = 0, CKPmn = 0)



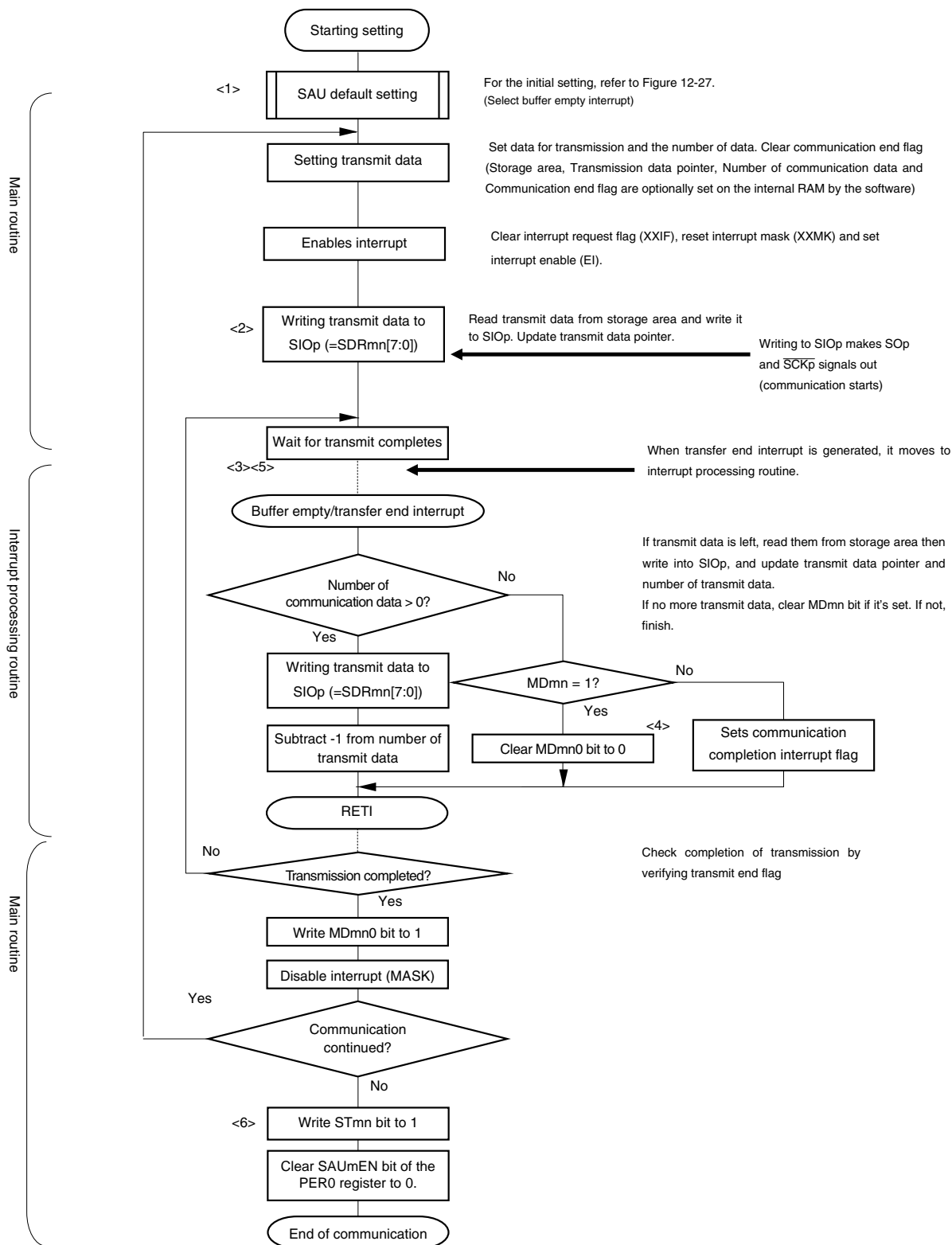
**Note** If transmit data is written to the SDRmn register while the BFFmn bit of serial status register mn (SSRmn) is 1 (valid data is stored in serial data register mn (SDRmn)), the transmit data is overwritten.

**Caution** The MDmn0 bit of serial mode register mn (SMRmn) can be rewritten even during operation. However, rewrite it before transfer of the last bit is started, so that it will be rewritten before the transfer end interrupt of the last transmit data.

**Remark** m: Unit number (m = 0, 1), n: Channel number (n = 0 to 3), p: CSI number (p = 00, 01, 10, 11, 20, 21, 30, 31), mn = 00 to 03, 10 to 13

<R>

Figure 12-33. Flowchart of Master Transmission (in Continuous Transmission Mode)



**Remark** <1> to <6> in the figure correspond to <1> to <6> in **Figure 12-32 Timing Chart of Master Transmission (in Continuous Transmission Mode)**.

### 12.5.2 Master reception

Master reception is that the RL78/G13 outputs a transfer clock and receives data from other device.

3-Wire Serial I/O	CSI00	CSI01	CSI10	CSI11	CSI20	CSI21	CSI30	CSI31
Target channel	Channel 0 of SAU0	Channel 1 of SAU0	Channel 2 of SAU0	Channel 3 of SAU0	Channel 0 of SAU1	Channel 1 of SAU1	Channel 2 of SAU1	Channel 3 of SAU1
Pins used	$\overline{\text{SCK00}}$ , SI00	$\overline{\text{SCK01}}$ , SI01	$\overline{\text{SCK10}}$ , SI10	$\overline{\text{SCK11}}$ , SI11	$\overline{\text{SCK20}}$ , SI20	$\overline{\text{SCK21}}$ , SI21	$\overline{\text{SCK30}}$ , SI30	$\overline{\text{SCK31}}$ , SI31
Interrupt	INTCSI00	INTCSI01	INTCSI10	INTCSI11	INTCSI20	INTCSI21	INTCSI30	INTCSI31
	Transfer end interrupt (in single-transfer mode) or buffer empty interrupt (in continuous transfer mode) can be selected.							
Error detection flag	Overrun error detection flag (OVFmn) only							
Transfer data length	7 or 8 bits							
Transfer rate	Max. $f_{\text{CLK}}/2$ [Hz] (CSI00), $f_{\text{CLK}}/4$ [Hz] (other than CSI00) Min. $f_{\text{CLK}}/(2 \times 2^{15} \times 128)$ [Hz] <sup>Note</sup> $f_{\text{CLK}}$ : System clock frequency							
Data phase	Selectable by the DAPmn bit of the SCRmn register <ul style="list-style-type: none"> <li>• DAPmn = 0: Data input starts from the start of the operation of the serial clock.</li> <li>• DAPmn = 1: Data input starts half a clock before the start of the serial clock operation.</li> </ul>							
Clock phase	Selectable by the CKPmn bit of the SCRmn register <ul style="list-style-type: none"> <li>• CKPmn = 0: Forward</li> <li>• CKPmn = 1: Reverse</li> </ul>							
Data direction	MSB or LSB first							

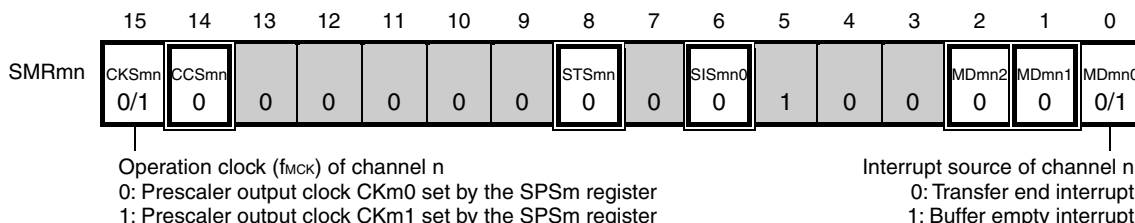
**Note** Use this operation within a range that satisfies the conditions above and the AC characteristics in the electrical specifications (see **CHAPTER 29 ELECTRICAL SPECIFICATIONS**).

**Remark** m: Unit number (m = 0, 1), n: Channel number (n = 0 to 3), mn = 00 to 03, 10 to 13

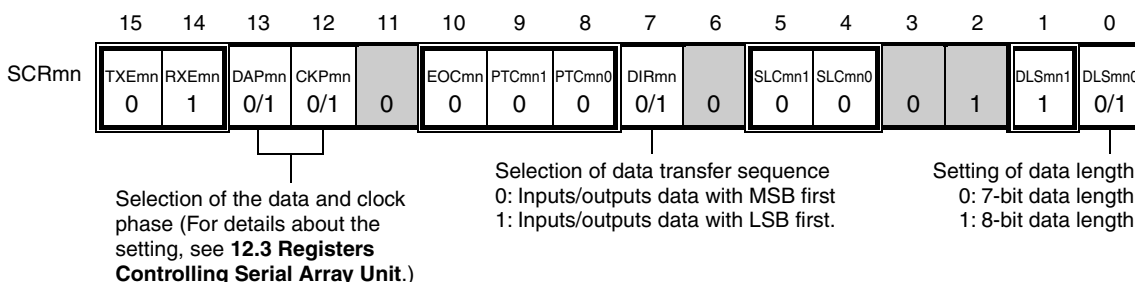
(1) Register setting

Figure 12-34. Example of Contents of Registers for Master Reception of 3-Wire Serial I/O (CSI00, CSI01, CSI10, CSI11, CSI20, CSI21, CSI30, CSI31) (1/2)

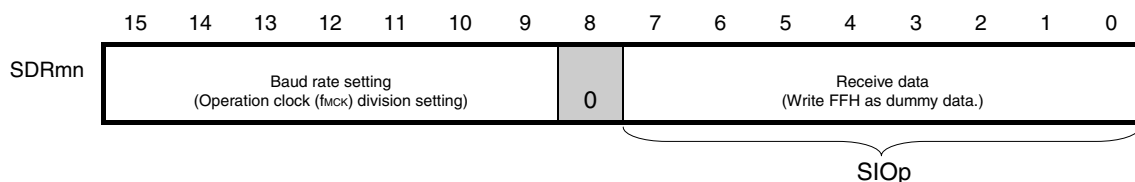
(a) Serial mode register mn (SMRmn)



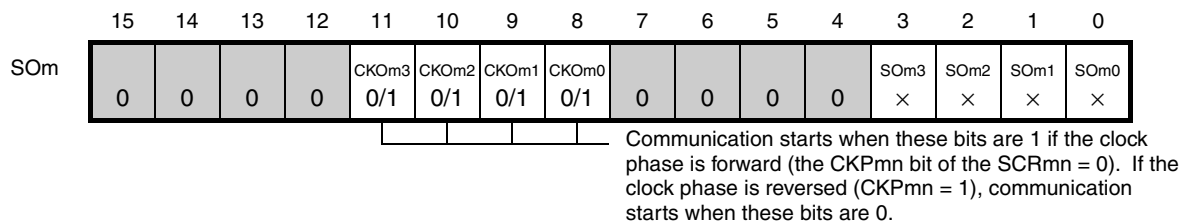
(b) Serial communication operation setting register mn (SCRmn)



(c) Serial data register mn (SDRmn) (lower 8 bits: SIOp)



(d) Serial output register m (SOM) ... Sets only the bits of the target channel.



- Remarks**
- m: Unit number (m = 0, 1), n: Channel number (n = 0 to 3), p: CSI number (p = 00, 01, 10, 11, 20, 21, 30, 31), mn = 00 to 03, 10 to 13
  - : Setting is fixed in the CSI master reception mode, ■: Setting disabled (set to the initial value)  
 ×: Bit that cannot be used in this mode (set to the initial value when not used in any mode)  
 0/1: Set to 0 or 1 depending on the usage of the user

**Figure 12-34. Example of Contents of Registers for Master Reception of 3-Wire Serial I/O (CSI00, CSI01, CSI10, CSI11, CSI20, CSI21, CSI30, CSI31) (2/2)**

**(e) Serial output enable register m (SOEm) ...The register that not used in this mode.**

	15	14	13	12	11	10	9	8	7	6	5	4	3	2	1	0
SOEm	0	0	0	0	0	0	0	0	0	0	0	0	SOEm3	SOEm2	SOEm1	SOEm0
													×	×	×	×

**(f) Serial channel start register m (SSm) ... Sets only the bits of the target channel to 1.**

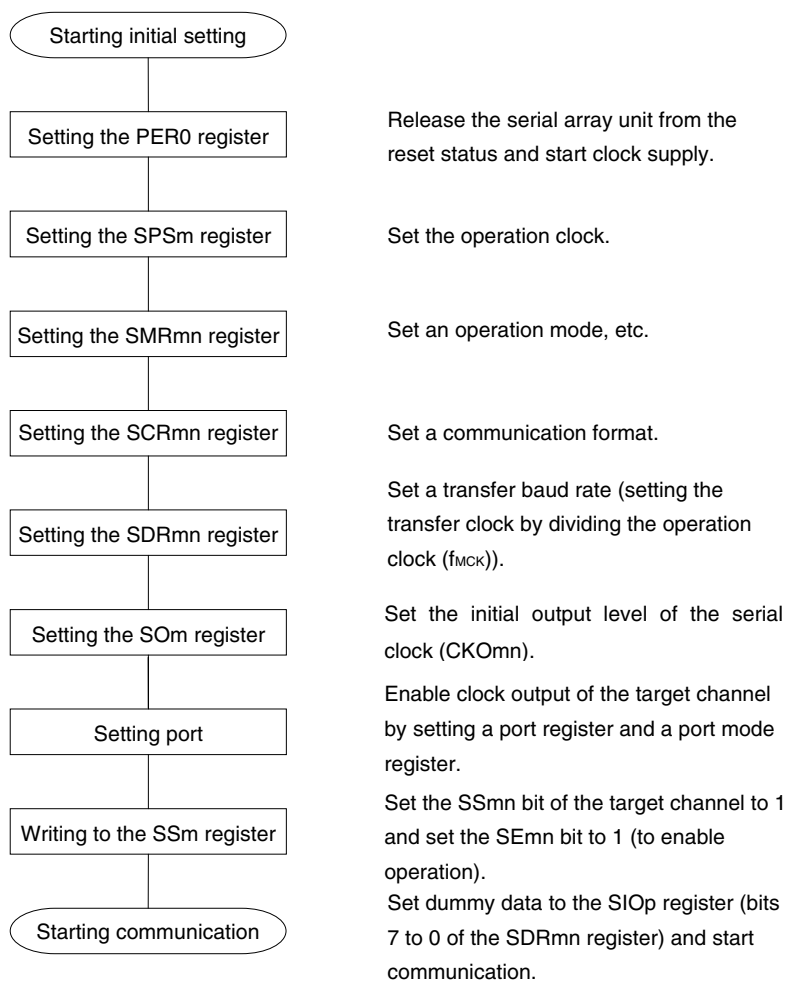
	15	14	13	12	11	10	9	8	7	6	5	4	3	2	1	0
SSm	0	0	0	0	0	0	0	0	0	0	0	0	SSm3	SSm2	SSm1	SSm0
													0/1	0/1	0/1	0/1

- Remarks**
- m: Unit number (m = 0, 1), n: Channel number (n = 0 to 3), p: CSI number (p = 00, 01, 10, 11, 20, 21, 30, 31)
  - : Setting disabled (set to the initial value)
    - ×: Bit that cannot be used in this mode (set to the initial value when not used in any mode)
    - 0/1: Set to 0 or 1 depending on the usage of the user

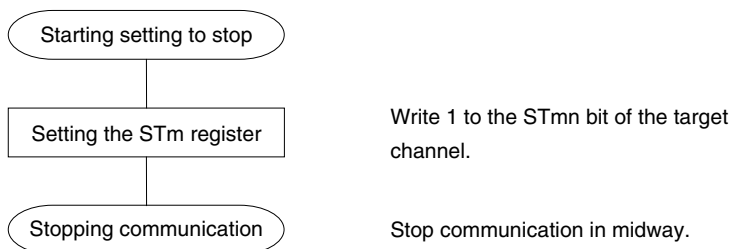


(2) Operation procedure

**Figure 12-35. Initial Setting Procedure for Master Reception**

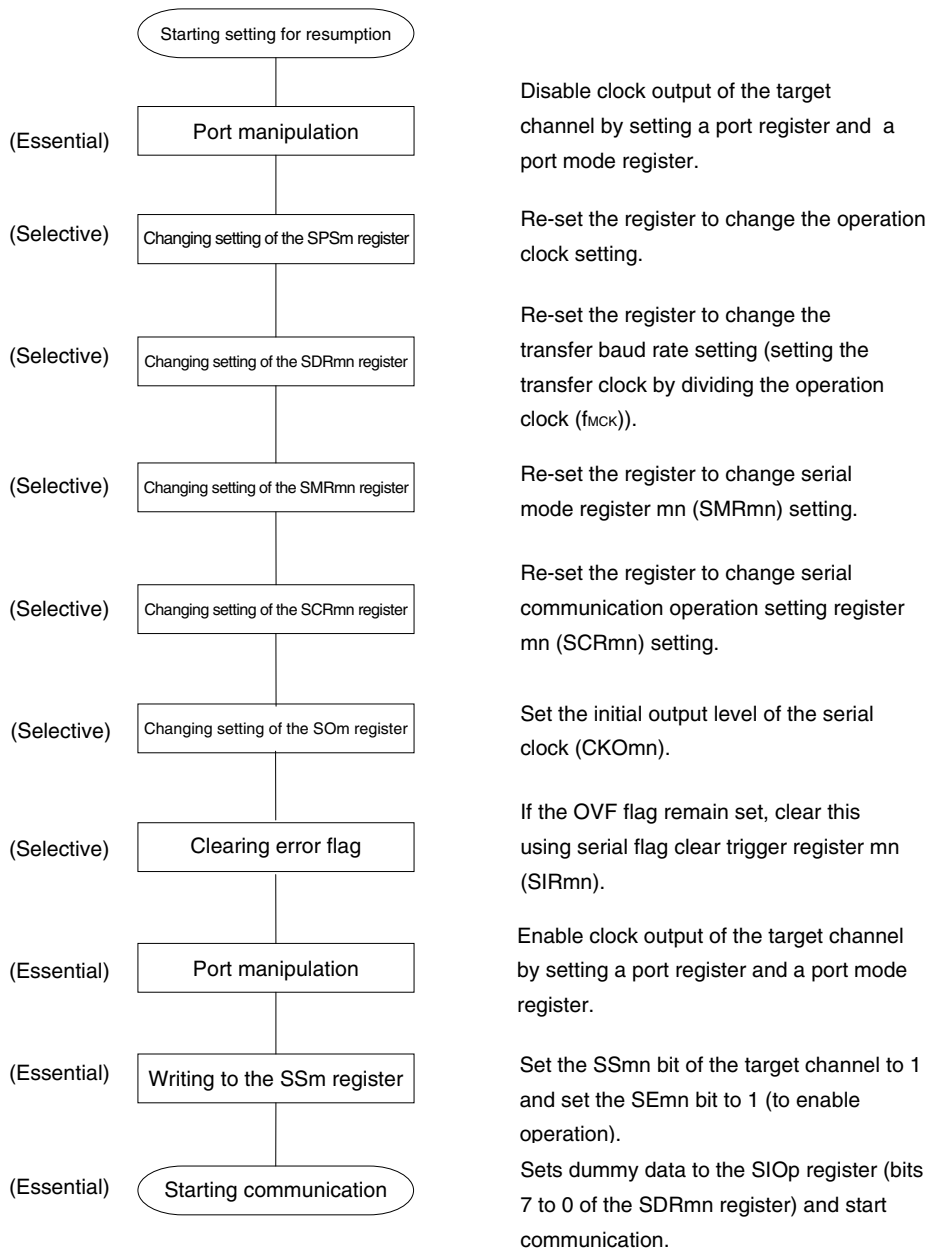


**Figure 12-36. Procedure for Stopping Master Reception**



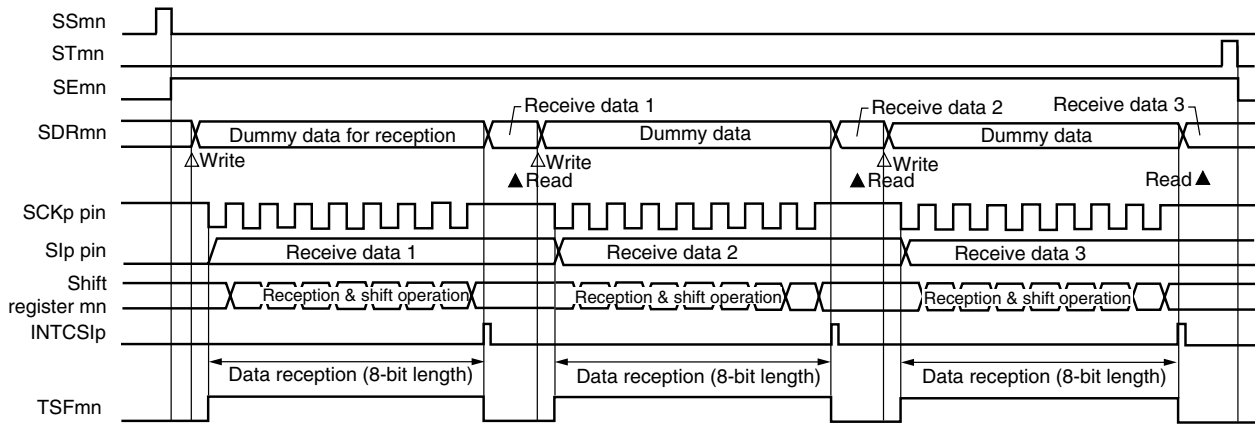
**Remark** Even after communication is stopped, the pin level is retained. To resume the operation, re-set serial output register m (SOm) (see **Figure 12-37 Procedure for Resuming Master Reception**).

**Figure 12-37. Procedure for Resuming Master Reception**



(3) Processing flow (in single-reception mode)

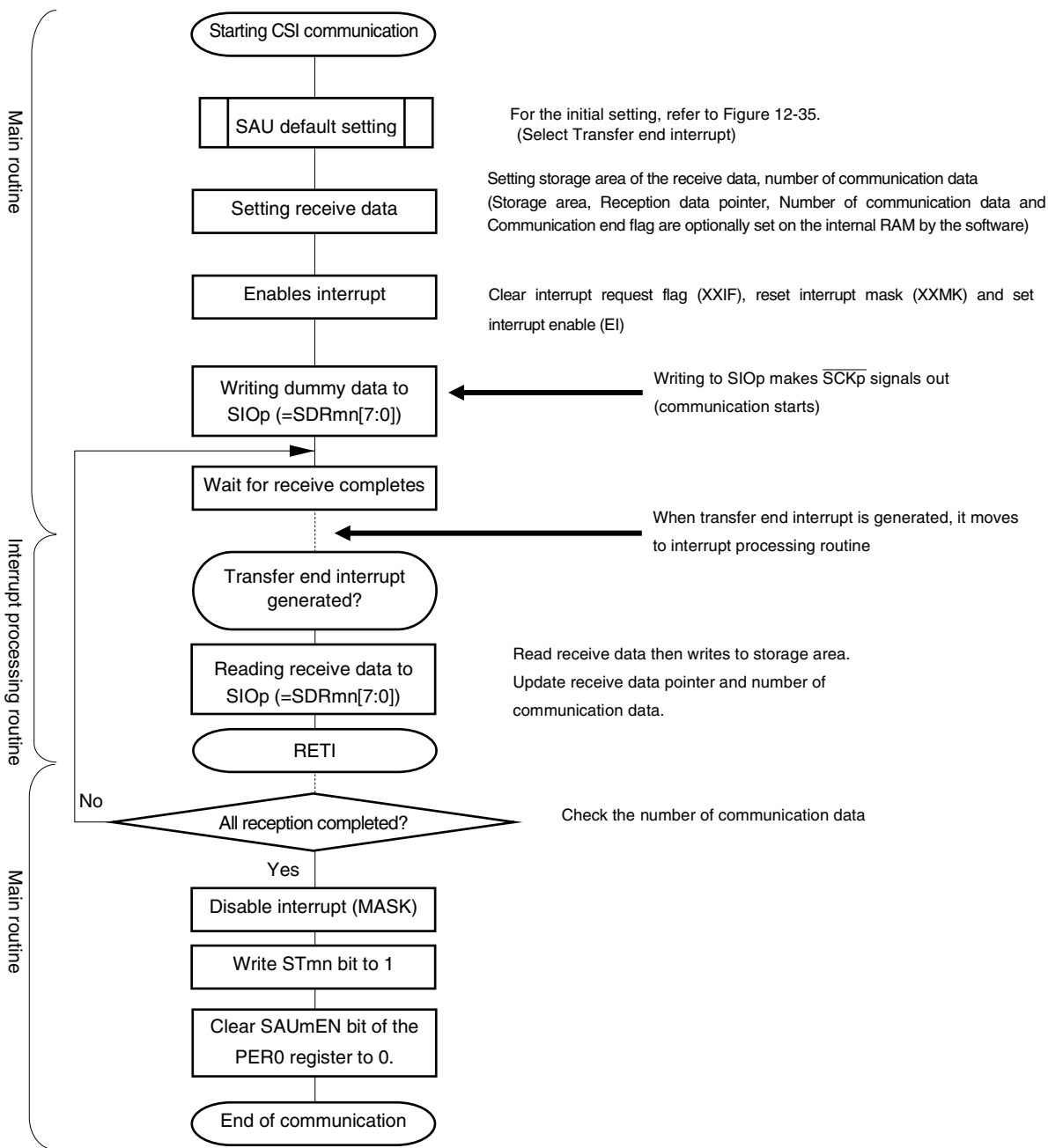
**Figure 12-38. Timing Chart of Master Reception (in Single-Reception Mode)**  
 (Type 1: DAPmn = 0, CKPmn = 0)



**Remark** m: Unit number (m = 0, 1), n: Channel number (n = 0 to 3), p: CSI number (p = 00, 01, 10, 11, 20, 21, 30, 31), mn = 00 to 03, 10 to 13

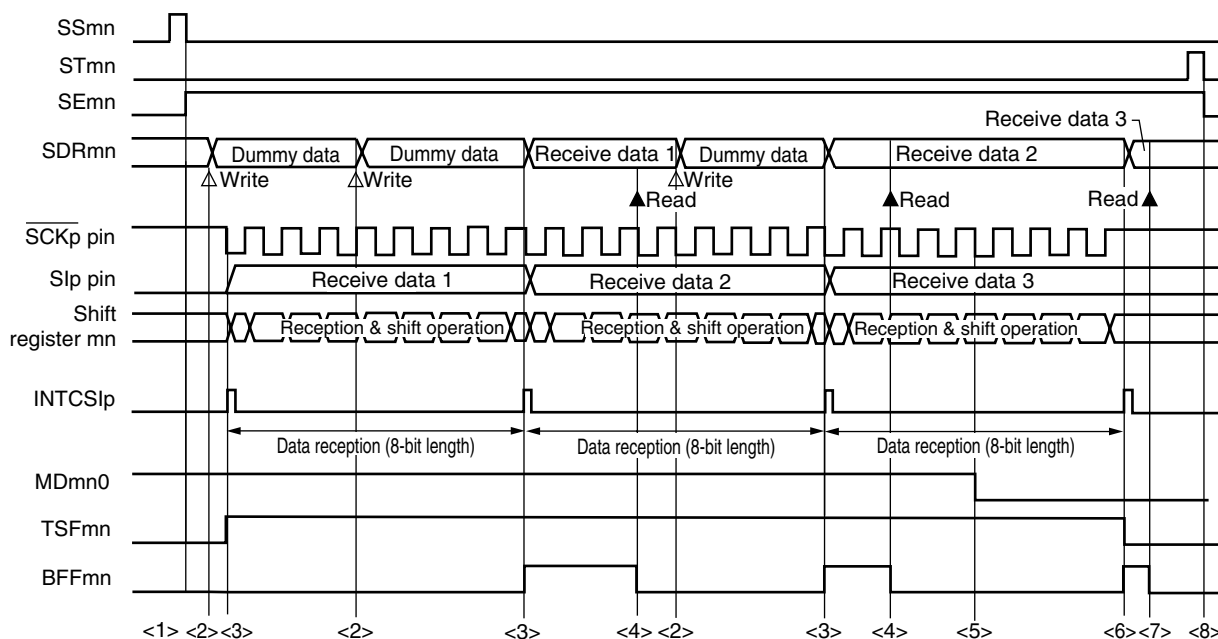
<R>

Figure 12-39. Flowchart of Master Reception (in Single-Reception Mode)



(4) Processing flow (in continuous reception mode)

Figure 12-40. Timing Chart of Master Reception (in Continuous Reception Mode) (Type 1: DAPmn = 0, CKPmn = 0)

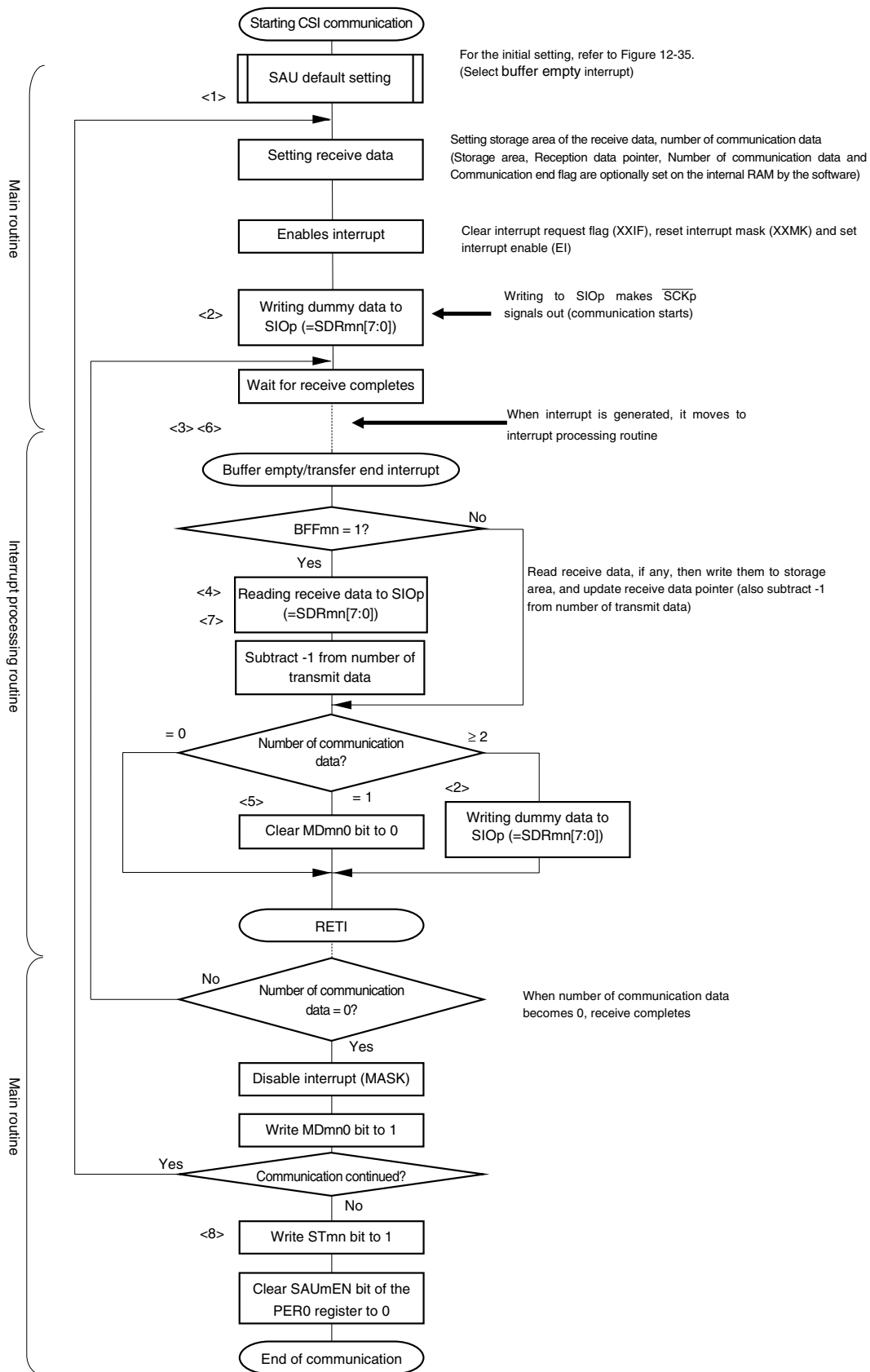


**Caution** The MDmn0 bit can be rewritten even during operation. However, rewrite it before receive of the last bit is started, so that it has been rewritten before the transfer end interrupt of the last receive data.

- Remarks 1.** <1> to <8> in the figure correspond to <1> to <8> in **Figure 12-41 Flowchart of Master Reception (in Continuous Reception Mode)**.
- 2.** m: Unit number (m = 0, 1), n: Channel number (n = 0 to 3), p: CSI number (p = 00, 01, 10, 11, 20, 21, 30, 31), mn = 00 to 03, 10 to 13

<R>

Figure 12-41. Flowchart of Master Reception (in Continuous Reception Mode)



**Remark** <1> to <8> in the figure correspond to <1> to <8> in **Figure 12-40 Timing Chart of Master Reception (in Continuous Reception Mode)**.

### 12.5.3 Master transmission/reception

Master transmission/reception is that the RL78/G13 outputs a transfer clock and transmits/receives data to/from other device.

3-Wire Serial I/O	CSI00	CSI01	CSI10	CSI11	CSI20	CSI21	CSI30	CSI31
Target channel	Channel 0 of SAU0	Channel 1 of SAU0	Channel 2 of SAU0	Channel 3 of SAU0	Channel 0 of SAU1	Channel 1 of SAU1	Channel 2 of SAU1	Channel 3 of SAU1
Pins used	$\overline{\text{SCK00}}$ , $\overline{\text{SI00}}$ , $\overline{\text{SO00}}$	$\overline{\text{SCK01}}$ , $\overline{\text{SI01}}$ , $\overline{\text{SO01}}$	$\overline{\text{SCK10}}$ , $\overline{\text{SI10}}$ , $\overline{\text{SO10}}$	$\overline{\text{SCK11}}$ , $\overline{\text{SI11}}$ , $\overline{\text{SO11}}$	$\overline{\text{SCK20}}$ , $\overline{\text{SI20}}$ , $\overline{\text{SO20}}$	$\overline{\text{SCK21}}$ , $\overline{\text{SI21}}$ , $\overline{\text{SO21}}$	$\overline{\text{SCK30}}$ , $\overline{\text{SI30}}$ , $\overline{\text{SO30}}$	$\overline{\text{SCK31}}$ , $\overline{\text{SI31}}$ , $\overline{\text{SO31}}$
Interrupt	INTCSI00	INTCSI01	INTCSI10	INTCSI11	INTCSI20	INTCSI21	INTCSI30	INTCSI31
	Transfer end interrupt (in single-transfer mode) or buffer empty interrupt (in continuous transfer mode) can be selected.							
Error detection flag	Overrun error detection flag (OVFmn) only							
Transfer data length	7 or 8 bits							
Transfer rate	Max. $f_{\text{CLK}}/2$ [Hz] (CSI00), $f_{\text{CLK}}/4$ [Hz] (other than CSI00) Min. $f_{\text{CLK}}/(2 \times 2^{15} \times 128)$ [Hz] <sup>Note</sup> $f_{\text{CLK}}$ : System clock frequency							
Data phase	Selectable by the DAPmn bit of the SCRmn register <ul style="list-style-type: none"> <li>DAPmn = 0: Data I/O starts at the start of the operation of the serial clock.</li> <li>DAPmn = 1: Data I/O starts half a clock before the start of the serial clock operation.</li> </ul>							
Clock phase	Selectable by the CKPmn bit of the SCRmn register <ul style="list-style-type: none"> <li>CKPmn = 0: Forward</li> <li>CKPmn = 1: Reverse</li> </ul>							
Data direction	MSB or LSB first							

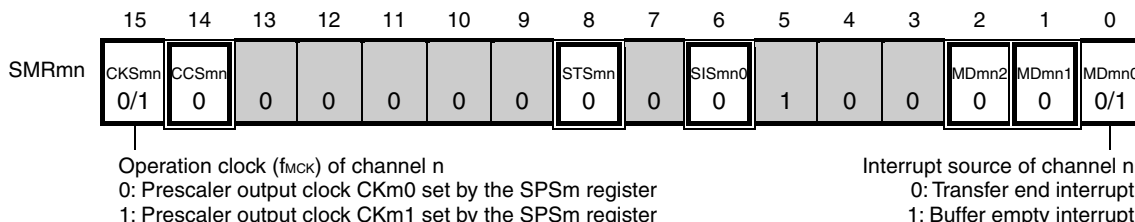
**Note** Use this operation within a range that satisfies the conditions above and the AC characteristics in the electrical specifications (see **CHAPTER 29 ELECTRICAL SPECIFICATIONS**).

**Remark** m: Unit number (m = 0, 1), n: Channel number (n = 0 to 3), mn = 00 to 03, 10 to 13

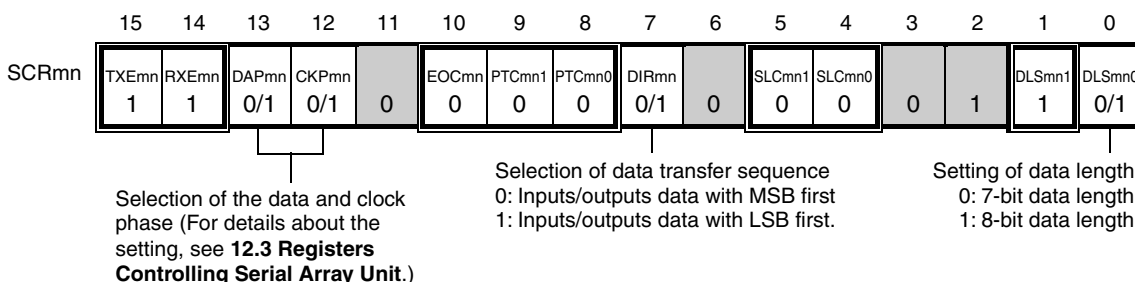
(1) Register setting

Figure 12-42. Example of Contents of Registers for Master Transmission/Reception of 3-Wire Serial I/O (CSI00, CSI01, CSI10, CSI11, CSI20, CSI21, CSI30, CSI31) (1/2)

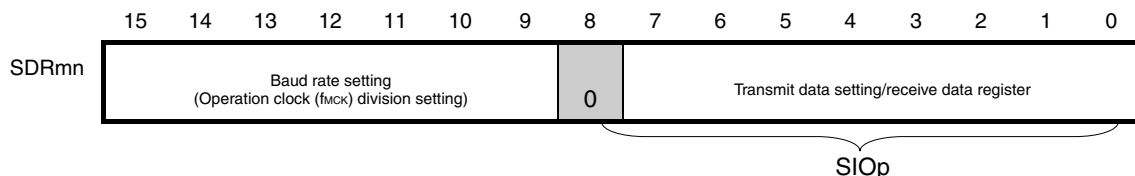
(a) Serial mode register mn (SMRmn)



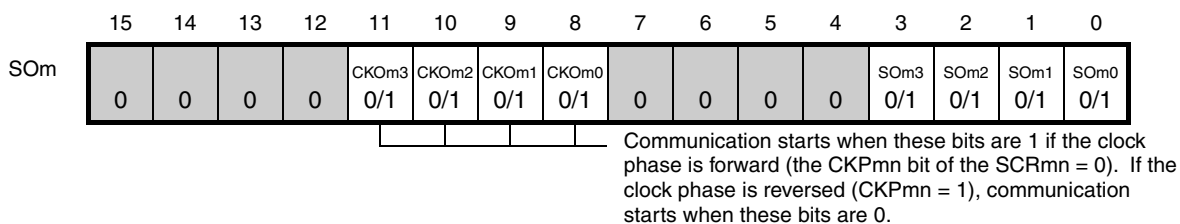
(b) Serial communication operation setting register mn (SCRmn)



(c) Serial data register mn (SDRmn) (lower 8 bits: SIOp)



(d) Serial output register m (SOM) ... Sets only the bits of the target channel.



- Remarks 1.** m: Unit number (m = 0, 1), n: Channel number (n = 0 to 3), p: CSI number (p = 00, 01, 10, 11, 20, 21, 30, 31), mn = 00 to 03, 10 to 13
- 2.** □: Setting is fixed in the CSI master transmission/reception mode  
 ■: Setting disabled (set to the initial value)  
 ×: Bit that cannot be used in this mode (set to the initial value when not used in any mode)  
 0/1: Set to 0 or 1 depending on the usage of the user



**Figure 12-42. Example of Contents of Registers for Master Transmission/Reception of 3-Wire Serial I/O (CSI00, CSI01, CSI10, CSI11, CSI20, CSI21, CSI30, CSI31) (2/2)**

**(e) Serial output enable register m (SOEm) ... Sets only the bits of the target channel to 1.**

	15	14	13	12	11	10	9	8	7	6	5	4	3	2	1	0
SOEm	0	0	0	0	0	0	0	0	0	0	0	0	SOEm3	SOEm2	SOEm1	SOEm0
													0/1	0/1	0/1	0/1

**(f) Serial channel start register m (SSm) ... Sets only the bits of the target channel to 1.**

	15	14	13	12	11	10	9	8	7	6	5	4	3	2	1	0
SSm	0	0	0	0	0	0	0	0	0	0	0	0	SSm3	SSm2	SSm1	SSm0
													0/1	0/1	0/1	0/1

**Note** Serial array unit 0 only.

- Remarks 1.** m: Unit number (m = 0, 1), n: Channel number (n = 0 to 3), p: CSI number (p = 00, 01, 10, 11, 20, 21, 30, 31), mn = 00 to 03, 10 to 13
- 2.**  : Setting disabled (set to the initial value)  
 ×: Bit that cannot be used in this mode (set to the initial value when not used in any mode)  
 0/1: Set to 0 or 1 depending on the usage of the user

(2) Operation procedure

Figure 12-43. Initial Setting Procedure for Master Transmission/Reception

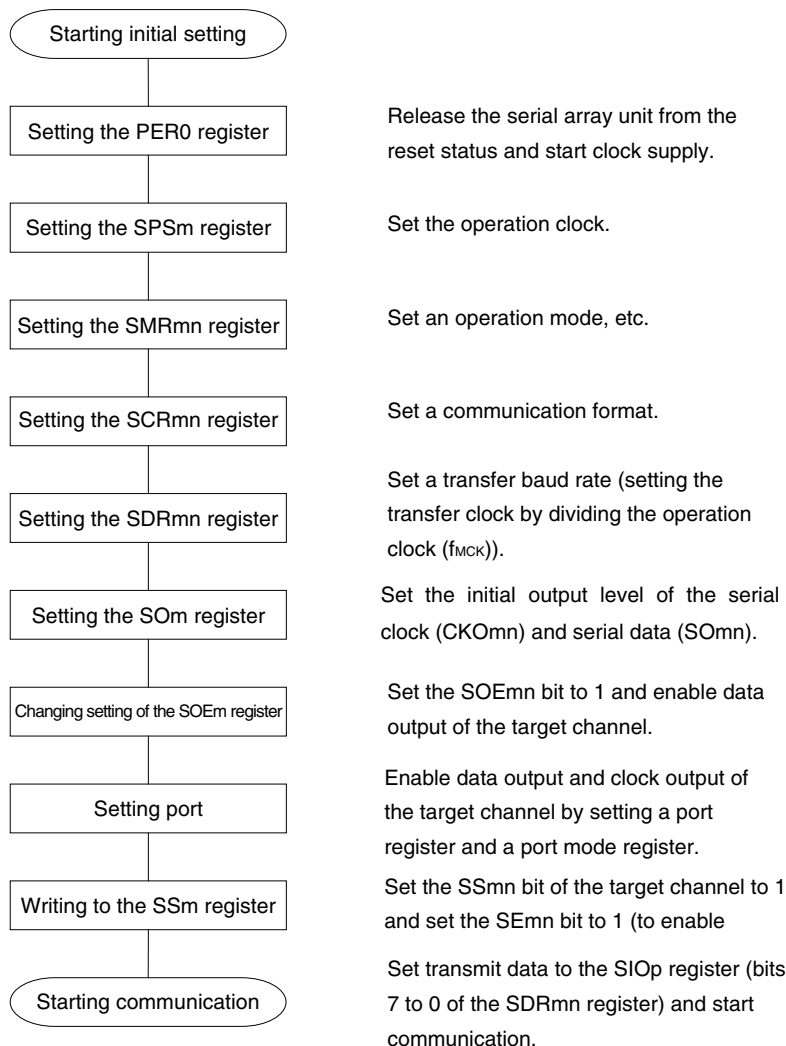
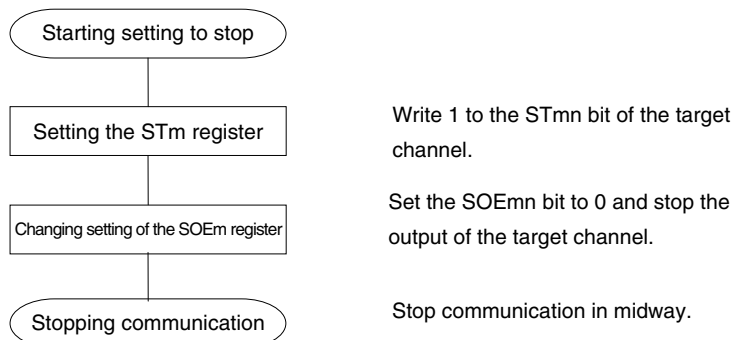
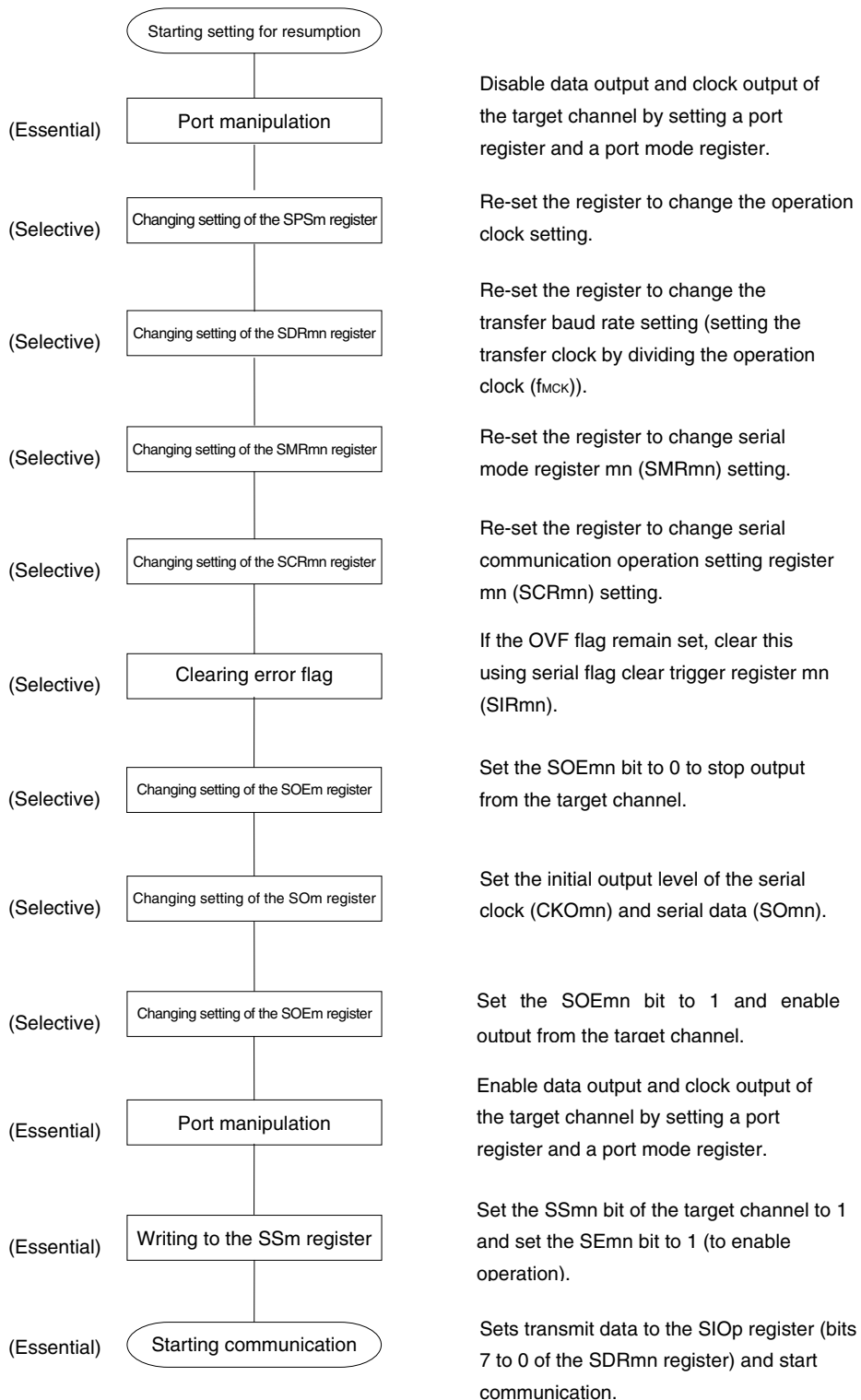


Figure 12-44. Procedure for Stopping Master Transmission/Reception



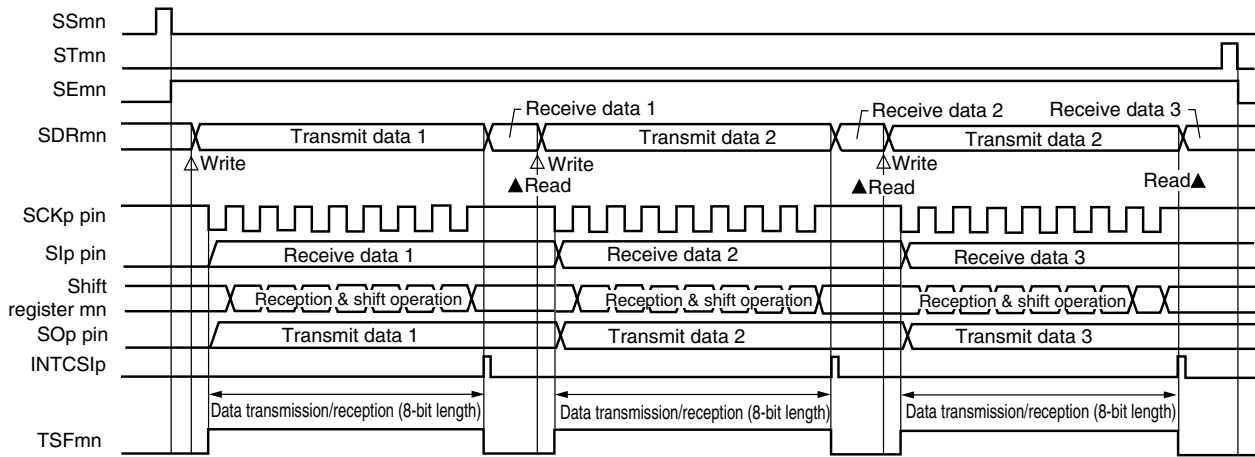
**Remark** Even after communication is stopped, the pin level is retained. To resume the operation, re-set serial output register m (SOm) (see **Figure 12-45 Procedure for Resuming Master Transmission**).

**Figure 12-45. Procedure for Resuming Master Transmission/Reception**



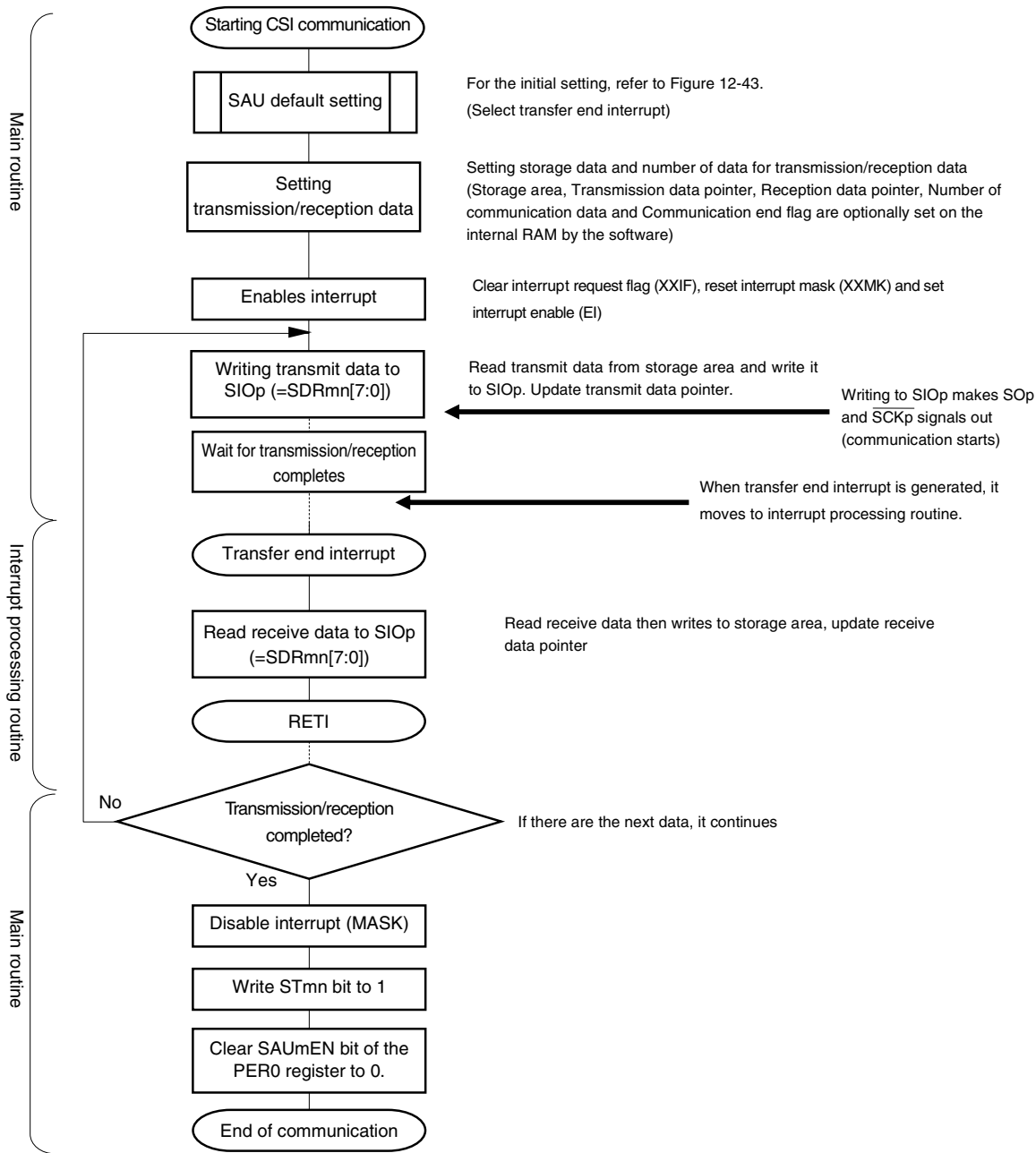
(3) Processing flow (in single-transmission/reception mode)

**Figure 12-46. Timing Chart of Master Transmission/Reception (in Single-Transmission/Reception Mode)**  
 (Type 1: DAPmn = 0, CKPmn = 0)



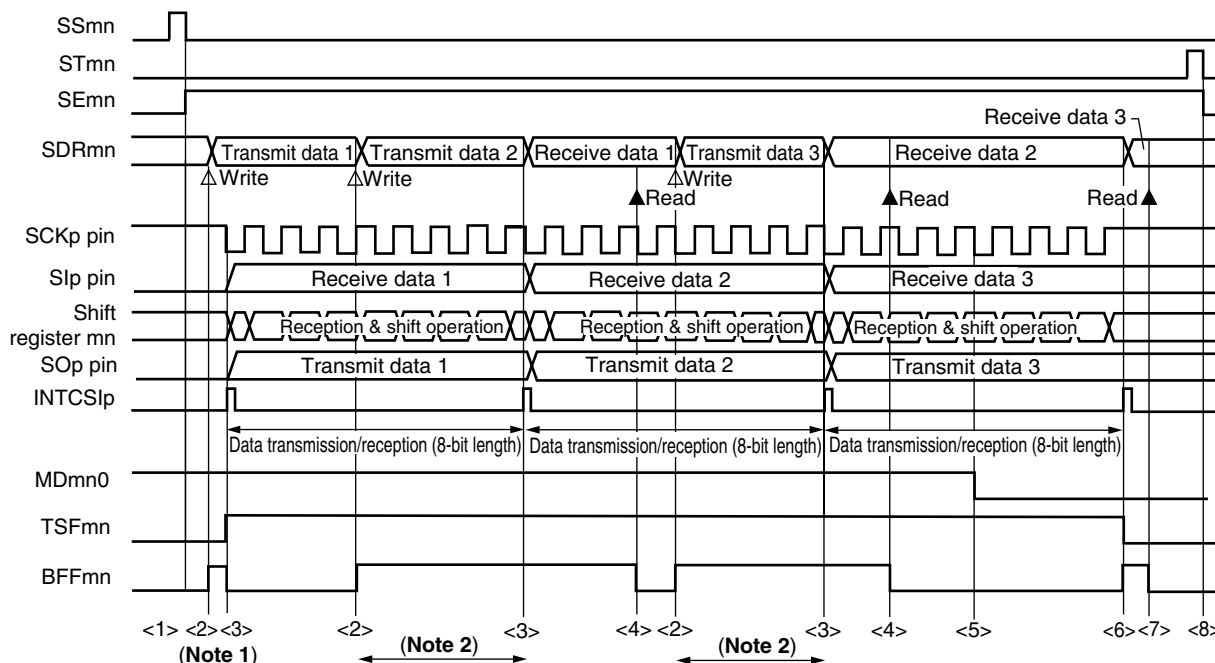
**Remark** m: Unit number (m = 0, 1), n: Channel number (n = 0 to 3), p: CSI number (p = 00, 01, 10, 11, 20, 21, 30, 31), mn = 00 to 03, 10 to 13

<R> **Figure 12-47. Flowchart of Master Transmission/Reception (in Single-Transmission/Reception Mode)**



(4) Processing flow (in continuous transmission/reception mode)

Figure 12-48. Timing Chart of Master Transmission/Reception (in Continuous Transmission/Reception Mode)  
(Type 1: DAPmn = 0, CKPmn = 0)

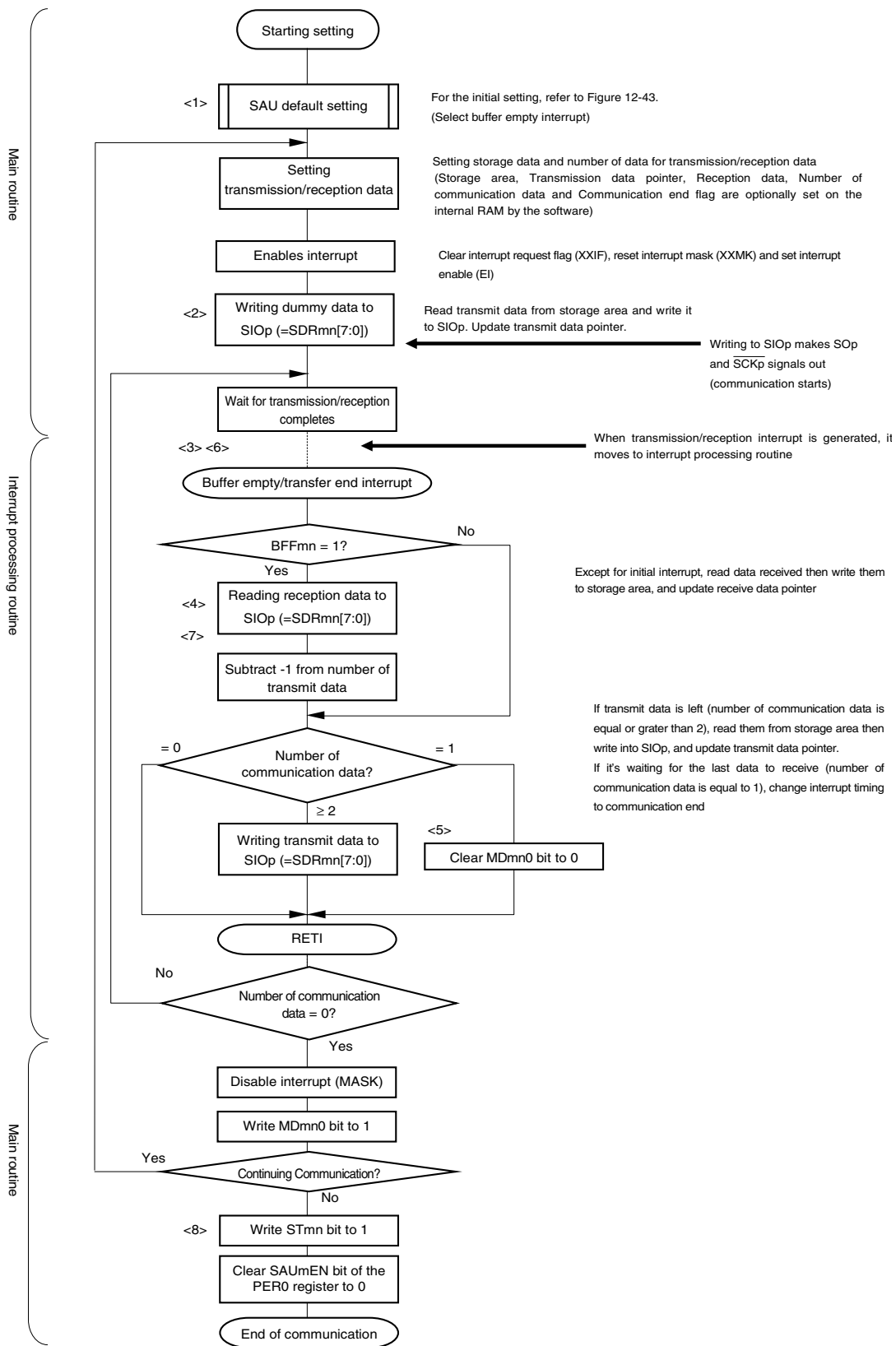


- Notes**
1. If transmit data is written to the SDRmn register while the BFFmn bit of serial status register mn (SSRmn) is 1 (valid data is stored in serial data register mn (SDRmn)), the transmit data is overwritten.
  2. The transmit data can be read by reading the SDRmn register during this period. At this time, the transfer operation is not affected.

**Caution** The MDmn0 bit of serial mode register mn (SMRmn) can be rewritten even during operation. However, rewrite it before transfer of the last bit is started, so that it has been rewritten before the transfer end interrupt of the last transmit data.

- Remarks**
1. <1> to <8> in the figure correspond to <1> to <8> in Figure 12-49 Flowchart of Master Transmission/Reception (in Continuous Transmission/Reception Mode).
  2. m: Unit number (m = 0, 1), n: Channel number (n = 0 to 3), p: CSI number (p = 00, 01, 10, 11, 20, 21, 30, 31), mn = 00 to 03, 10 to 13

<R> Figure 12-49. Flowchart of Master Transmission/Reception (in Continuous Transmission/Reception Mode)



**Remark** <1> to <8> in the figure correspond to <1> to <8> in Figure 12-48 Timing Chart of Master Transmission/Reception (in Continuous Transmission/Reception Mode).

### 12.5.4 Slave transmission

Slave transmission is that the RL78/G13 transmits data to another device in the state of a transfer clock being input from another device.

3-Wire Serial I/O	CSI00	CSI01	CSI10	CSI11	CSI20	CSI21	CSI30	CSI31
Target channel	Channel 0 of SAU0	Channel 1 of SAU0	Channel 2 of SAU0	Channel 3 of SAU0	Channel 0 of SAU1	Channel 1 of SAU1	Channel 2 of SAU1	Channel 3 of SAU1
Pins used	$\overline{\text{SCK00}}$ , SO00	$\overline{\text{SCK01}}$ , SO01	$\overline{\text{SCK10}}$ , SO10	$\overline{\text{SCK11}}$ , SO11	$\overline{\text{SCK20}}$ , SO20	$\overline{\text{SCK21}}$ , SO21	$\overline{\text{SCK30}}$ , SO30	$\overline{\text{SCK31}}$ , SO31
Interrupt	INTCSI00	INTCSI01	INTCSI10	INTCSI11	INTCSI20	INTCSI21	INTCSI30	INTCSI31
	Transfer end interrupt (in single-transfer mode) or buffer empty interrupt (in continuous transfer mode) can be selected.							
Error detection flag	Overrun error detection flag (OVFmn) only							
Transfer data length	7 or 8 bits							
Transfer rate	Max. $f_{\text{MCK}}/6$ [Hz] <sup>Notes 1, 2</sup>							
Data phase	Selectable by the DAPmn bit of the SCRmn register <ul style="list-style-type: none"> <li>• DAPmn = 0: Data output starts from the start of the operation of the serial clock.</li> <li>• DAPmn = 1: Data output starts half a clock before the start of the serial clock operation.</li> </ul>							
Clock phase	Selectable by the CKPmn bit of the SCRmn register <ul style="list-style-type: none"> <li>• CKPmn = 0: Forward</li> <li>• CKPmn = 1: Reverse</li> </ul>							
Data direction	MSB or LSB first							

**Notes 1.** Because the external serial clock input to the  $\overline{\text{SCK00}}$ ,  $\overline{\text{SCK01}}$ ,  $\overline{\text{SCK10}}$ ,  $\overline{\text{SCK11}}$ ,  $\overline{\text{SCK20}}$ ,  $\overline{\text{SCK21}}$ ,  $\overline{\text{SCK30}}$ , and  $\overline{\text{SCK31}}$  pins is sampled internally and used, the fastest transfer rate is  $f_{\text{MCK}}/6$  [Hz].

**2.** Use this operation within a range that satisfies the conditions above and the AC characteristics in the electrical specifications (see **CHAPTER 29 ELECTRICAL SPECIFICATIONS**).

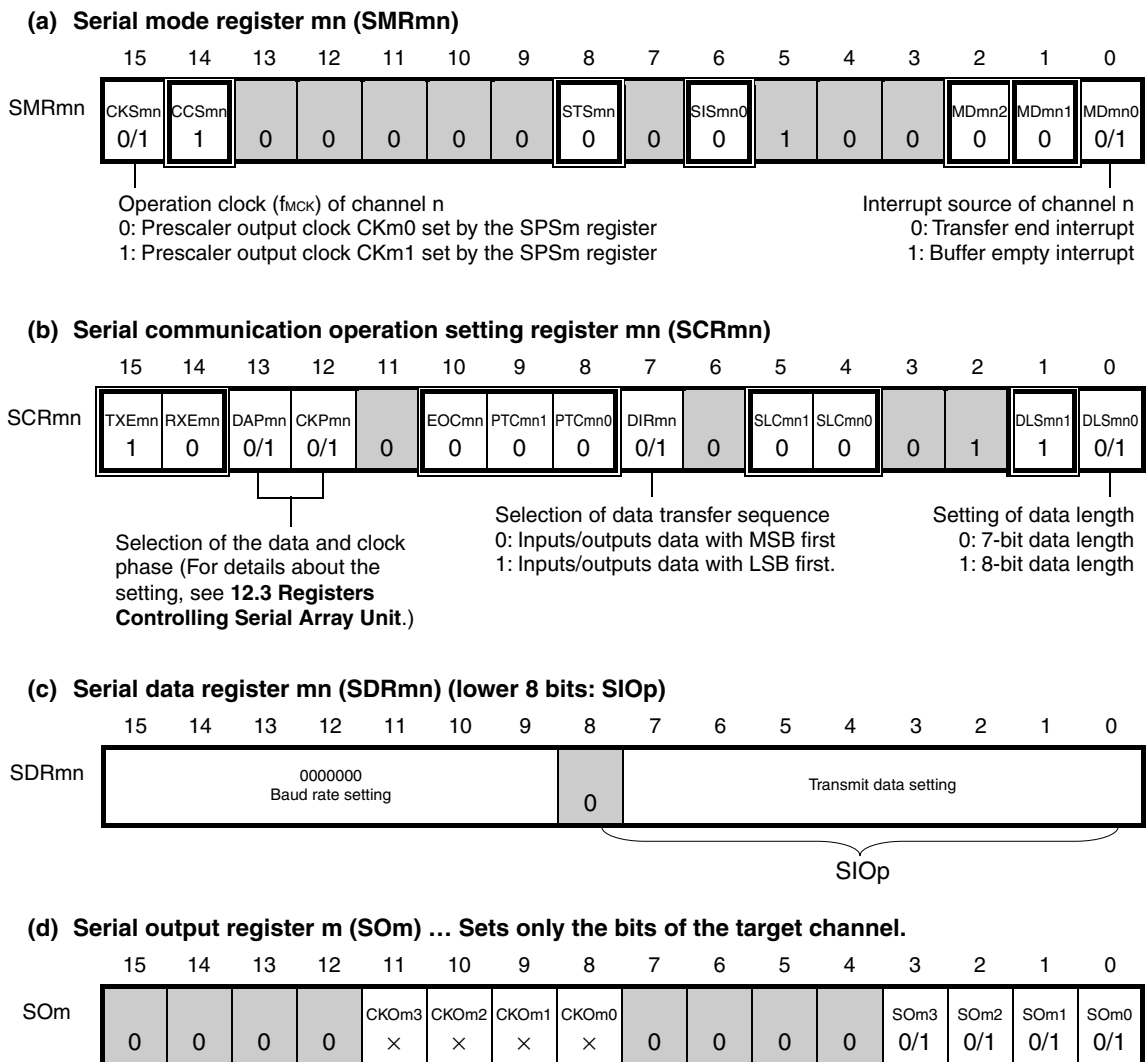
**Remarks 1.**  $f_{\text{MCK}}$ : Operation clock frequency of target channel

**2.** m: Unit number (m = 0, 1), n: Channel number (n = 0 to 3), mn = 00 to 03, 10 to 13



(1) Register setting

**Figure 12-50. Example of Contents of Registers for Slave Transmission of 3-Wire Serial I/O (CSI00, CSI01, CSI10, CSI11, CSI20, CSI21, CSI30, CSI31) (1/2)**



- Remarks 1.** m: Unit number (m = 0, 1), n: Channel number (n = 0 to 3), p: CSI number (p = 00, 01, 10, 11, 20, 21, 30, 31), mn = 00 to 03, 10 to 13
- 2.** □: Setting is fixed in the CSI slave transmission mode, ■: Setting disabled (set to the initial value)  
 ×: Bit that cannot be used in this mode (set to the initial value when not used in any mode)  
 0/1: Set to 0 or 1 depending on the usage of the user

**Figure 12-50. Example of Contents of Registers for Slave Transmission of 3-Wire Serial I/O (CSI00, CSI01, CSI10, CSI11, CSI20, CSI21, CSI30, CSI31) (2/2)**

**(e) Serial output enable register m (SOEm) ... Sets only the bits of the target channel to 1.**

	15	14	13	12	11	10	9	8	7	6	5	4	3	2	1	0
SOEm	0	0	0	0	0	0	0	0	0	0	0	0	SOEm3 0/1	SOEm2 0/1	SOEm1 0/1	SOEm0 0/1

**(f) Serial channel start register m (SSm) ... Sets only the bits of the target channel to 1.**

	15	14	13	12	11	10	9	8	7	6	5	4	3	2	1	0
SSm	0	0	0	0	0	0	0	0	0	0	0	0	SSm3 0/1	SSm2 0/1	SSm1 0/1	SSm0 0/1

- Remarks**
1. m: Unit number (m = 0, 1), n: Channel number (n = 0 to 3), p: CSI number (p = 00, 01, 10, 11, 20, 21, 30, 31), mn = 00 to 03, 10 to 13
  2. : Setting disabled (set to the initial value)  
 ×: Bit that cannot be used in this mode (set to the initial value when not used in any mode)  
 0/1: Set to 0 or 1 depending on the usage of the user

(2) Operation procedure

Figure 12-51. Initial Setting Procedure for Slave Transmission

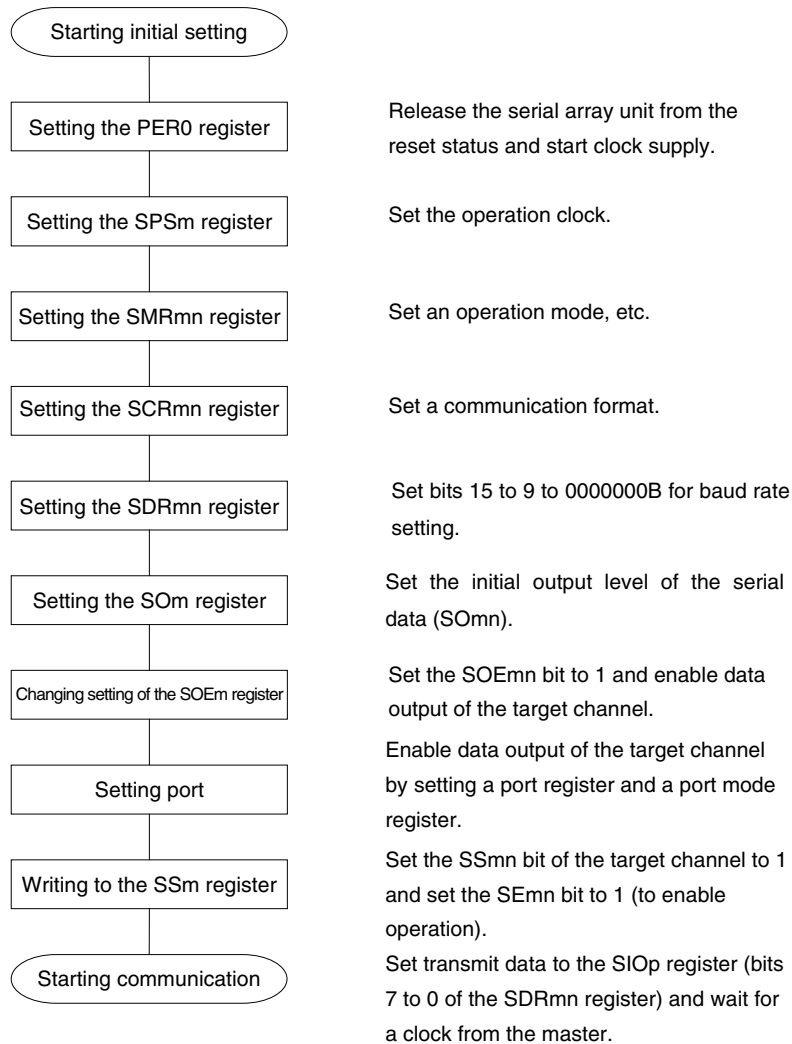
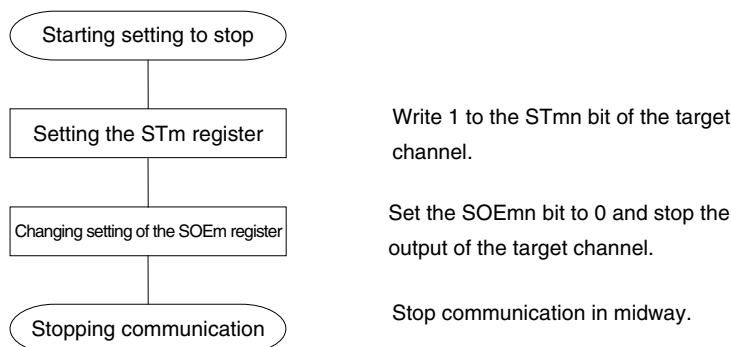
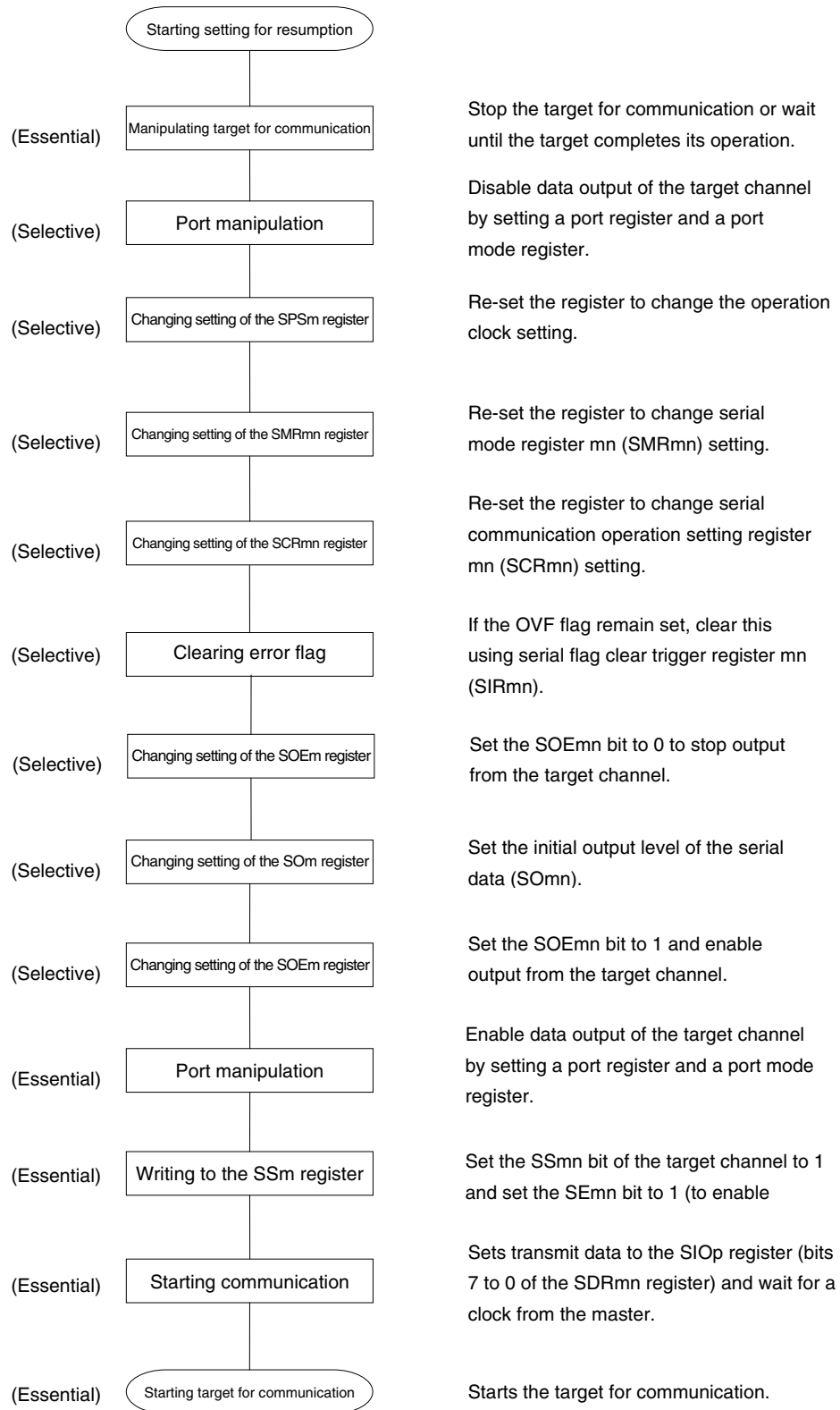


Figure 12-52. Procedure for Stopping Slave Transmission



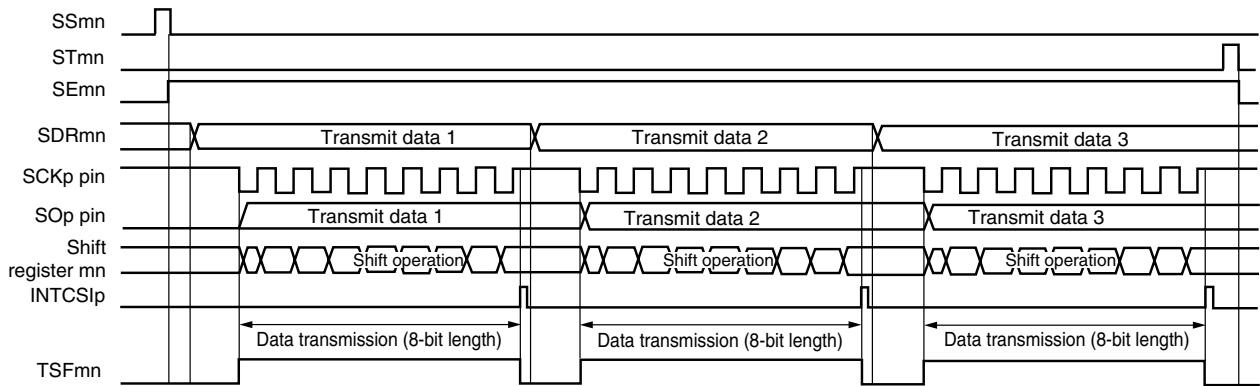
**Remark** Even after communication is stopped, the pin level is retained. To resume the operation, re-set the SOm register (see **Figure 12-53 Procedure for Resuming Slave Transmission**).

Figure 12-53. Procedure for Resuming Slave Transmission



(3) Processing flow (in single-transmission mode)

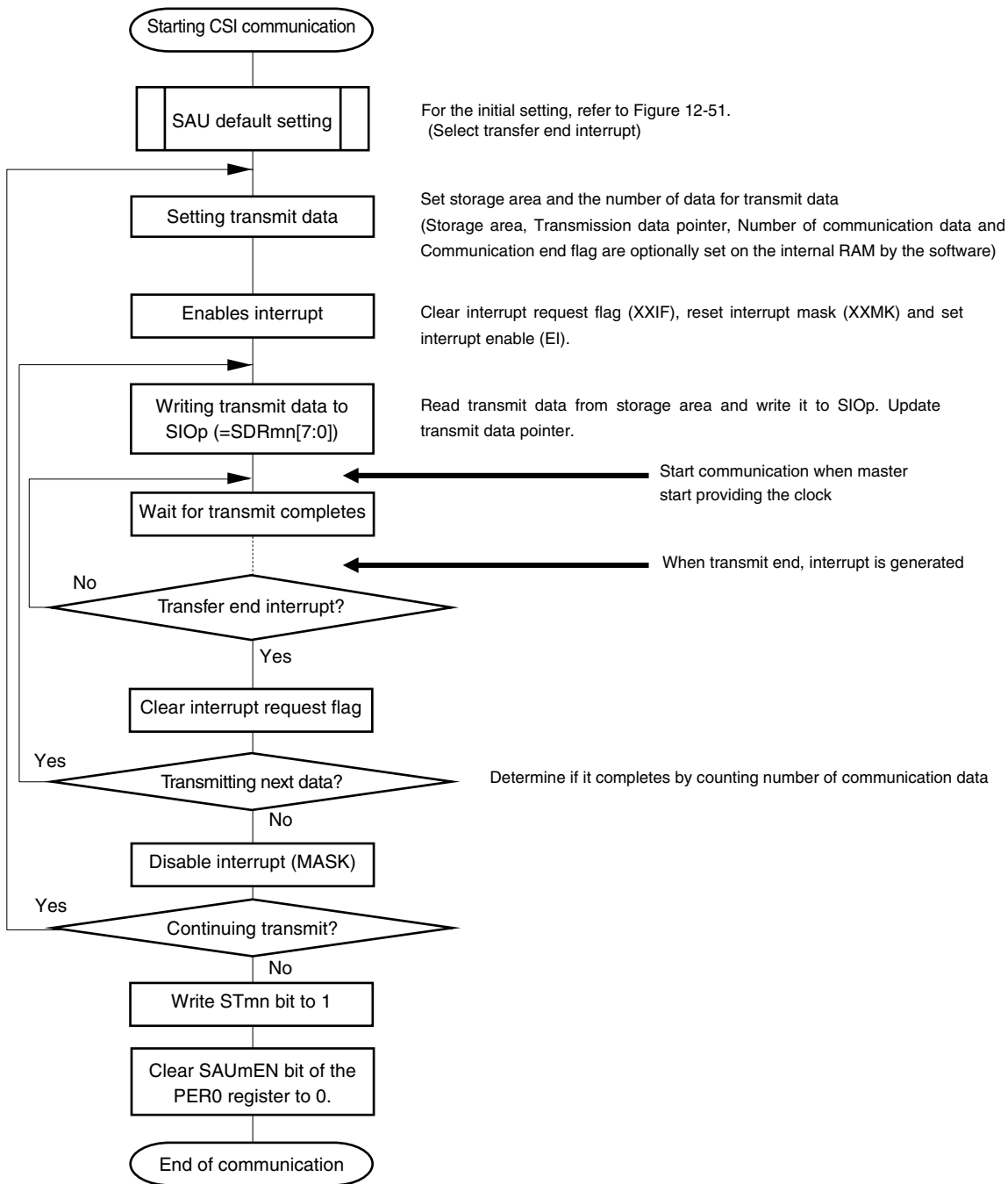
**Figure 12-54. Timing Chart of Slave Transmission (in Single-Transmission Mode)**  
 (Type 1: DAPmn = 0, CKPmn = 0)



**Remark** m: Unit number (m = 0, 1), n: Channel number (n = 0 to 3), p: CSI number (p = 00, 01, 10, 11, 20, 21, 30, 31), mn = 00 to 03, 10 to 13

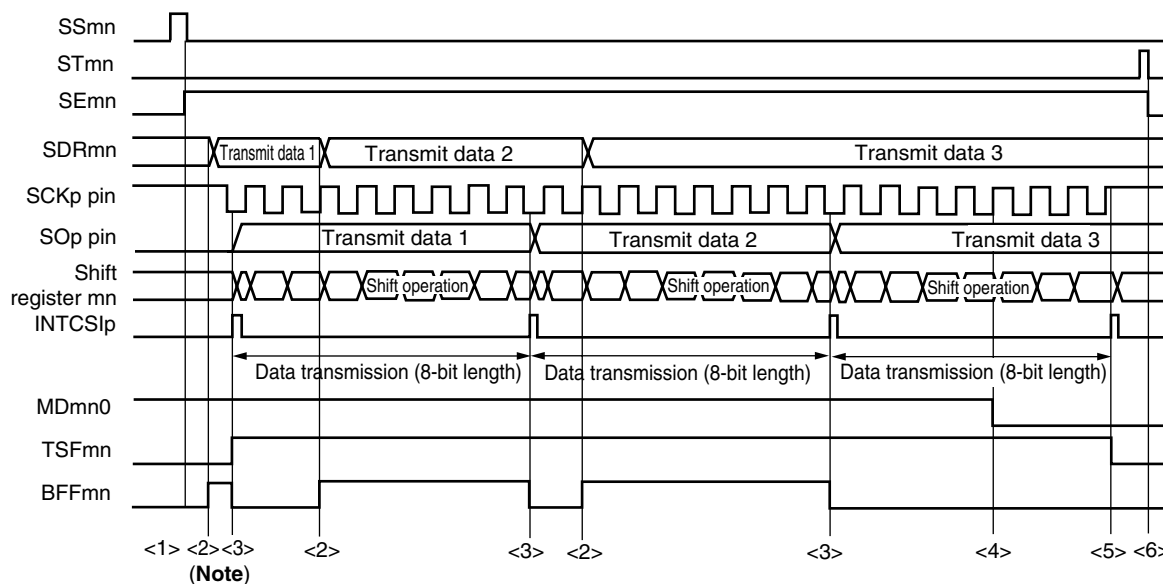
<R>

Figure 12-55. Flowchart of Slave Transmission (in Single-Transmission Mode)



(4) Processing flow (in continuous transmission mode)

Figure 12-56. Timing Chart of Slave Transmission (in Continuous Transmission Mode)  
(Type 1: DAPmn = 0, CKPmn = 0)



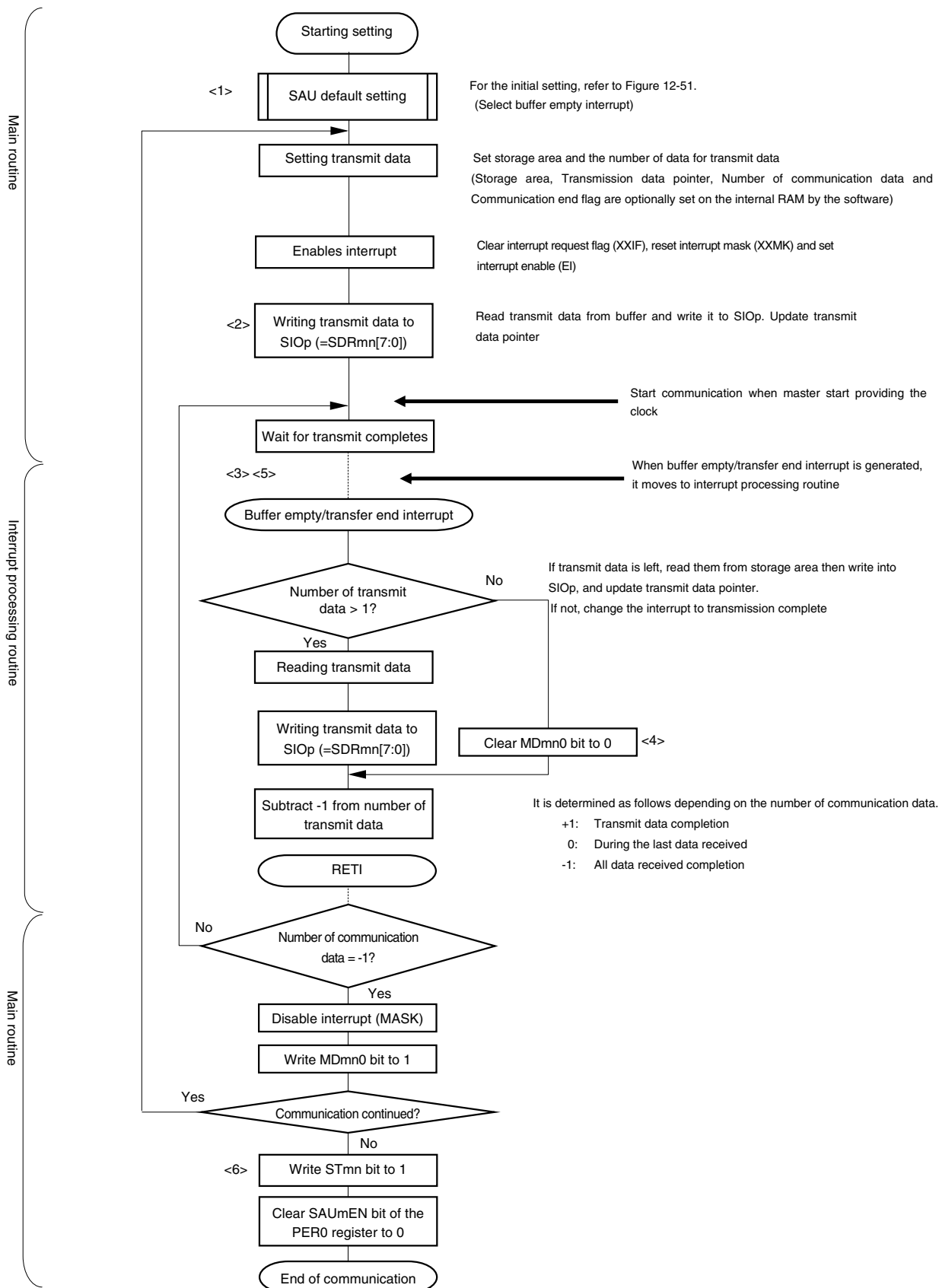
**Note** If transmit data is written to the SDRmn register while the BFFmn bit of serial status register mn (SSRmn) is 1 (valid data is stored in serial data register mn (SDRmn)), the transmit data is overwritten.

**Caution** The MDmn0 bit of serial mode register mn (SMRmn) can be rewritten even during operation. However, rewrite it before transfer of the last bit is started.

**Remark** m: Unit number (m = 0, 1), n: Channel number (n = 0 to 3), p: CSI number (p = 00, 01, 10, 11, 20, 21, 30, 31), mn = 00 to 03, 10 to 13

<R>

Figure 12-57. Flowchart of Slave Transmission (in Continuous Transmission Mode)



Remark <1> to <6> in the figure correspond to <1> to <6> in Figure 12-56 Timing Chart of Slave Transmission (in Continuous Transmission Mode).



### 12.5.5 Slave reception

Slave reception is that the RL78/G13 receives data from another device in the state of a transfer clock being input from another device.

3-Wire Serial I/O	CSI00	CSI01	CSI10	CSI11	CSI20	CSI21	CSI30	CSI31
Target channel	Channel 0 of SAU0	Channel 1 of SAU0	Channel 2 of SAU0	Channel 3 of SAU0	Channel 0 of SAU1	Channel 1 of SAU1	Channel 2 of SAU1	Channel 3 of SAU1
Pins used	$\overline{\text{SCK00}}$ , SI00	$\overline{\text{SCK01}}$ , SI01	$\overline{\text{SCK10}}$ , SI10	$\overline{\text{SCK11}}$ , SI11	$\overline{\text{SCK20}}$ , SI20	$\overline{\text{SCK21}}$ , SI21	$\overline{\text{SCK30}}$ , SI30	$\overline{\text{SCK31}}$ , SI31
Interrupt	INTCSI00	INTCSI01	INTCSI10	INTCSI11	INTCSI20	INTCSI21	INTCSI30	INTCSI31
	Transfer end interrupt only (Setting the buffer empty interrupt is prohibited.)							
Error detection flag	Overflow error detection flag (OVFmn) only							
Transfer data length	7 or 8 bits							
Transfer rate	Max. $f_{\text{MCK}}/6$ [Hz] <sup>Notes 1, 2</sup>							
Data phase	Selectable by the DAPmn bit of the SCRmn register <ul style="list-style-type: none"> <li>• DAPmn = 0: Data input starts from the start of the operation of the serial clock.</li> <li>• DAPmn = 1: Data input starts half a clock before the start of the serial clock operation.</li> </ul>							
Clock phase	Selectable by the CKPmn bit of the SCRmn register <ul style="list-style-type: none"> <li>• CKPmn = 0: Forward</li> <li>• CKPmn = 1: Reverse</li> </ul>							
Data direction	MSB or LSB first							

**Notes 1.** Because the external serial clock input to the  $\overline{\text{SCK00}}$ ,  $\overline{\text{SCK01}}$ ,  $\overline{\text{SCK10}}$ ,  $\overline{\text{SCK11}}$ ,  $\overline{\text{SCK20}}$ ,  $\overline{\text{SCK21}}$ ,  $\overline{\text{SCK30}}$ , and  $\overline{\text{SCK31}}$  pins is sampled internally and used, the fastest transfer rate is  $f_{\text{MCK}}/6$  [Hz].

**2.** Use this operation within a range that satisfies the conditions above and the AC characteristics in the electrical specifications (see **CHAPTER 29 ELECTRICAL SPECIFICATIONS**).

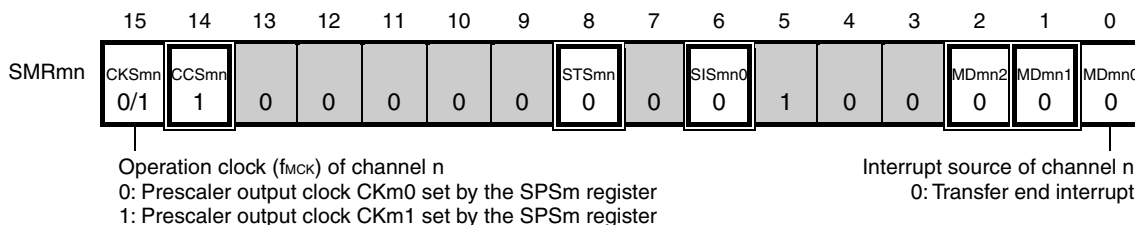
**Remarks 1.**  $f_{\text{MCK}}$ : Operation clock frequency of target channel

**2.** m: Unit number (m = 0, 1), n: Channel number (n = 0 to 3), mn = 00 to 03, 10 to 13

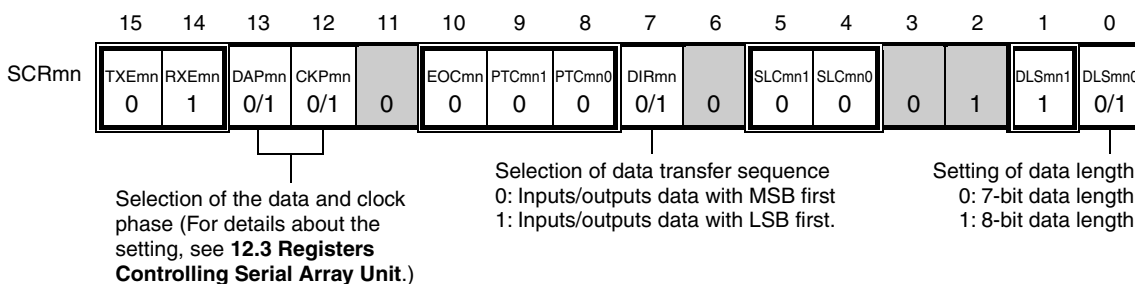
(1) Register setting

**Figure 12-58. Example of Contents of Registers for Slave Reception of 3-Wire Serial I/O (CSI00, CSI01, CSI10, CSI11, CSI20, CSI21, CSI30, CSI31)**

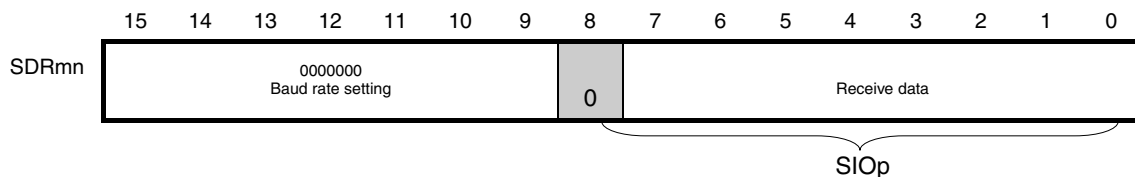
**(a) Serial mode register mn (SMRmn)**



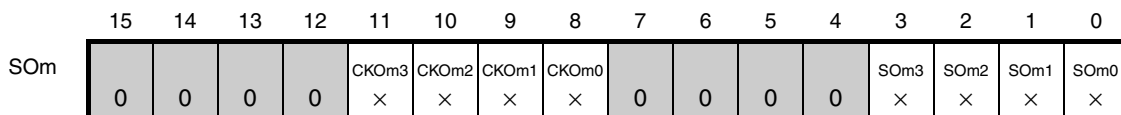
**(b) Serial communication operation setting register mn (SCRmn)**



**(c) Serial data register mn (SDRmn) (lower 8 bits: SIOp)**



**(d) Serial output register m (SOM) ...The Register that not used in this mode.**



- Remarks**
- m: Unit number (m = 0, 1), n: Channel number (n = 0 to 3), p: CSI number (p = 00, 01, 10, 11, 20, 21, 30, 31), mn = 00 to 03, 10 to 13
  - : Setting is fixed in the CSI slave transmission mode, ■: Setting disabled (set to the initial value)  
 ×: Bit that cannot be used in this mode (set to the initial value when not used in any mode)  
 0/1: Set to 0 or 1 depending on the usage of the user

**Figure 12-58. Example of Contents of Registers for Slave Reception of 3-Wire Serial I/O (CSI00, CSI01, CSI10, CSI11, CSI20, CSI21) (2/2)**

**(e) Serial output enable register m (SOEm) ...The Register that not used in this mode.**

	15	14	13	12	11	10	9	8	7	6	5	4	3	2	1	0
SOEm	0	0	0	0	0	0	0	0	0	0	0	0	SOEm3	SOEm2	SOEm1	SOEm0
													×	×	×	×

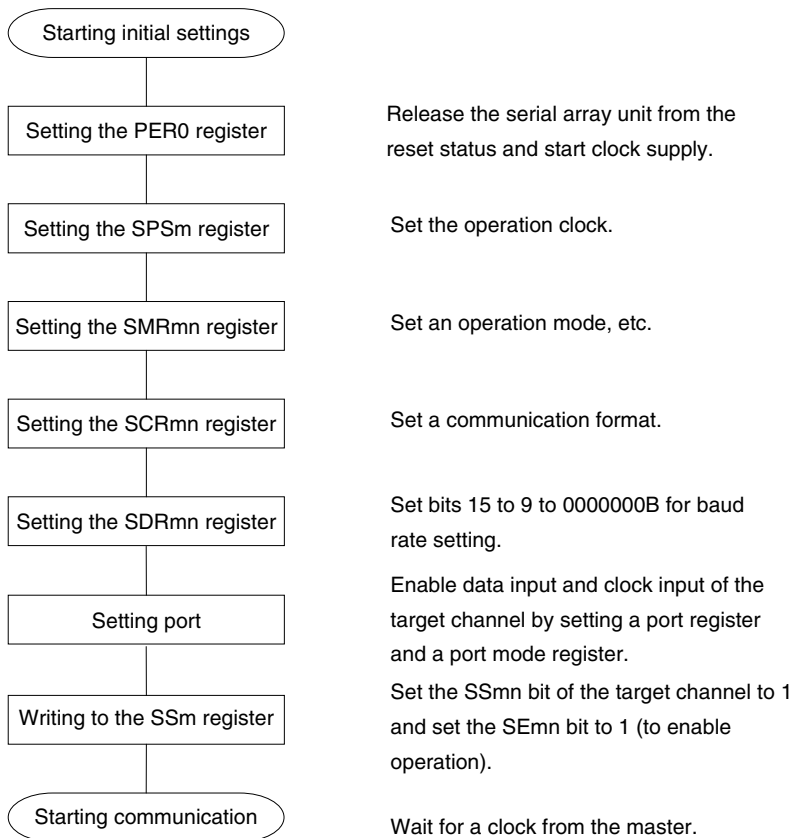
**(f) Serial channel start register m (SSm) ... Sets only the bits of the target channel to 1.**

	15	14	13	12	11	10	9	8	7	6	5	4	3	2	1	0
SSm	0	0	0	0	0	0	0	0	0	0	0	0	SSm3	SSm2	SSm1	SSm0
													0/1	0/1	0/1	0/1

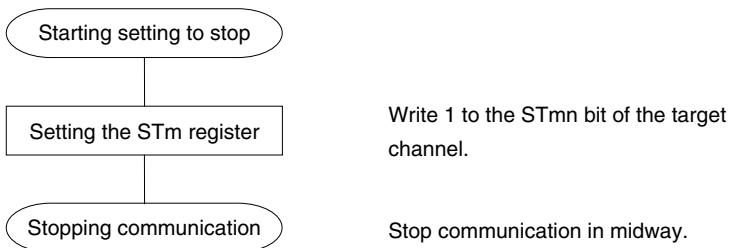
- Remarks**
1. m: Unit number (m = 0, 1), n: Channel number (n = 0 to 3), p: CSI number (p = 00, 01, 10, 11, 20, 21, 30, 31), mn = 00 to 03, 10 to 13
  2.  : Setting disabled (set to the initial value)  
 ×: Bit that cannot be used in this mode (set to the initial value when not used in any mode)  
 0/1: Set to 0 or 1 depending on the usage of the user

(2) Operation procedure

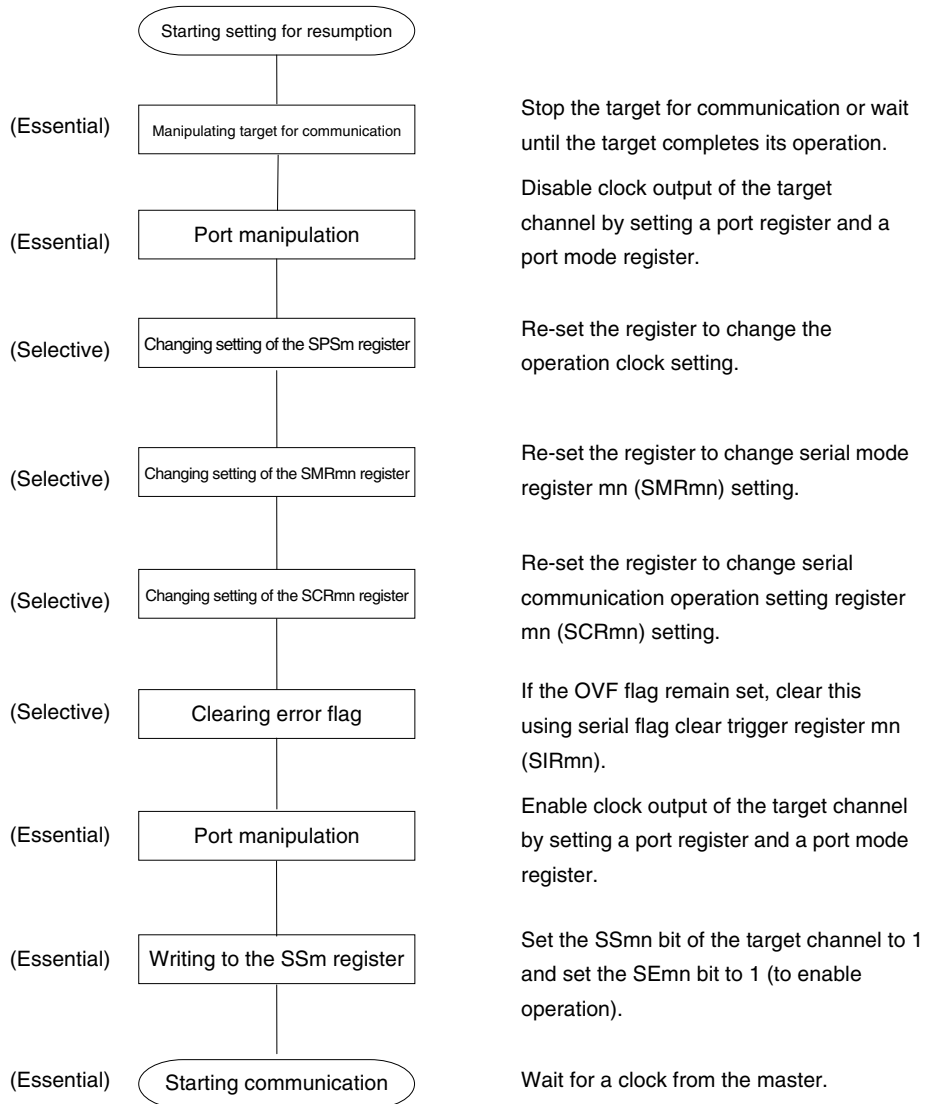
**Figure 12-59. Initial Setting Procedure for Slave Reception**



**Figure 12-60. Procedure for Stopping Slave Reception**

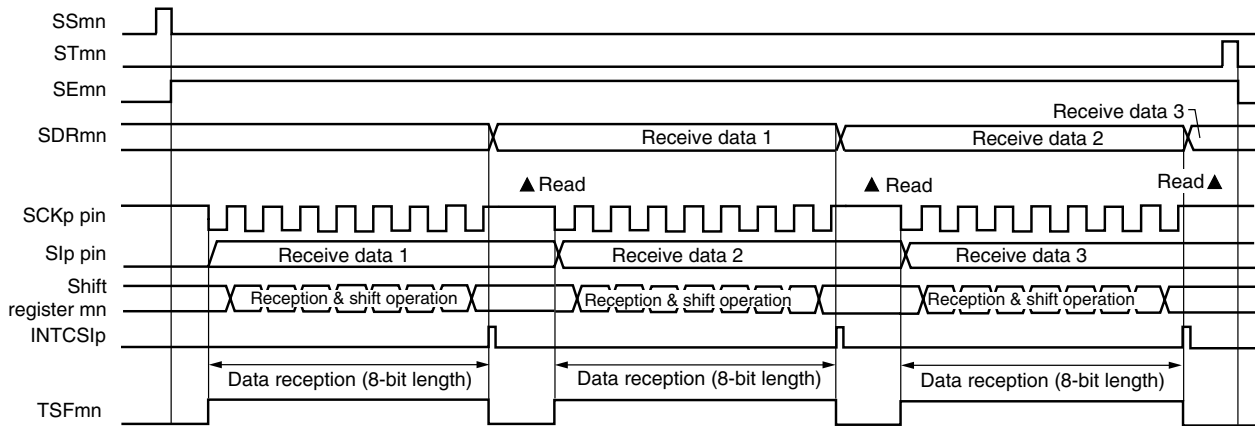


**Figure 12-61. Procedure for Resuming Slave Reception**



(3) Processing flow (in single-reception mode)

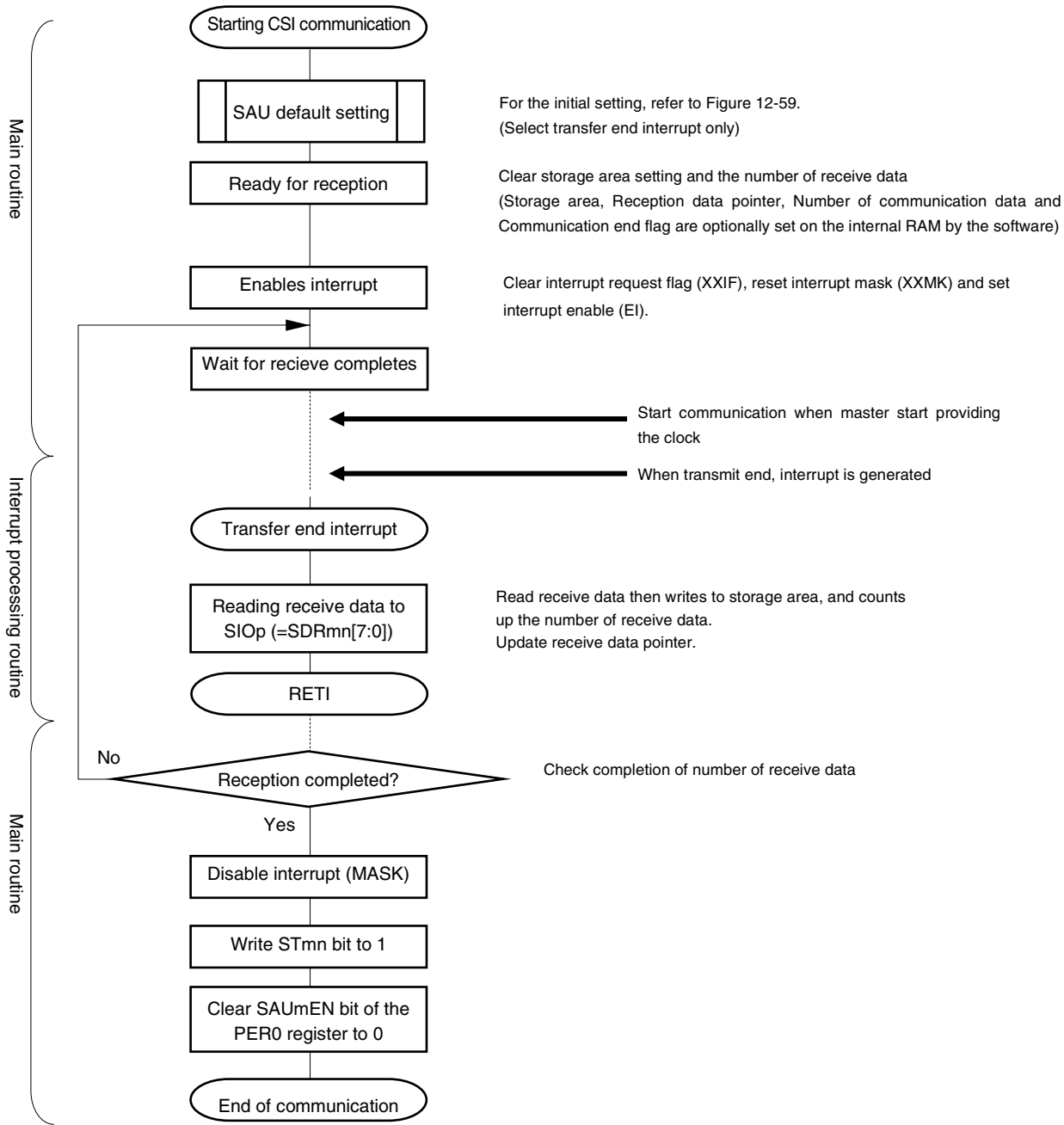
Figure 12-62. Timing Chart of Slave Reception (in Single-Reception Mode)  
(Type 1: DAPmn = 0, CKPmn = 0)



**Remark** m: Unit number (m = 0, 1), n: Channel number (n = 0 to 3), p: CSI number (p = 00, 01, 10, 11, 20, 21, 30, 31), mn = 00 to 03, 10 to 13

<R>

Figure 12-63. Flowchart of Slave Reception (in Single-Reception Mode)



### 12.5.6 Slave transmission/reception

Slave transmission/reception is that the RL78/G13 transmits/receives data to/from another device in the state of a transfer clock being input from another device.

3-Wire Serial I/O	CSI00	CSI01	CSI10	CSI11	CSI20	CSI21	CSI30	CSI31
Target channel	Channel 0 of SAU0	Channel 1 of SAU0	Channel 2 of SAU0	Channel 3 of SAU0	Channel 0 of SAU1	Channel 1 of SAU1	Channel 2 of SAU1	Channel 3 of SAU1
Pins used	$\overline{\text{SCK00}}$ , SI00, SO00	$\overline{\text{SCK01}}$ , SI01, SO01	$\overline{\text{SCK10}}$ , SI10, SO10	$\overline{\text{SCK11}}$ , SI11, SO11	$\overline{\text{SCK20}}$ , SI20, SO20	$\overline{\text{SCK21}}$ , SI21, SO21	$\overline{\text{SCK30}}$ , SI30, SO30	$\overline{\text{SCK31}}$ , SI31, SO31
Interrupt	INTCSI00	INTCSI01	INTCSI10	INTCSI11	INTCSI20	INTCSI21	INTCSI30	INTCSI31
	Transfer end interrupt (in single-transfer mode) or buffer empty interrupt (in continuous transfer mode) can be selected.							
Error detection flag	Overrun error detection flag (OVFmn) only							
Transfer data length	7 or 8 bits							
Transfer rate	Max. $f_{\text{MCK}}/6$ [Hz] <sup>Notes 1, 2</sup>							
Data phase	Selectable by the DAPmn bit of the SCRmn register <ul style="list-style-type: none"> <li>DAPmn = 0: Data I/O starts from the start of the operation of the serial clock.</li> <li>DAPmn = 1: Data I/O starts half a clock before the start of the serial clock operation.</li> </ul>							
Clock phase	Selectable by the CKPmn bit of the SCRmn register <ul style="list-style-type: none"> <li>CKPmn = 0: Forward</li> <li>CKPmn = 1: Reverse</li> </ul>							
Data direction	MSB or LSB first							

**Notes 1.** Because the external serial clock input to the  $\overline{\text{SCK00}}$ ,  $\overline{\text{SCK01}}$ ,  $\overline{\text{SCK10}}$ ,  $\overline{\text{SCK11}}$ ,  $\overline{\text{SCK20}}$ ,  $\overline{\text{SCK21}}$ ,  $\overline{\text{SCK30}}$ , and  $\overline{\text{SCK31}}$  pins is sampled internally and used, the fastest transfer rate is  $f_{\text{MCK}}/6$  [Hz].

**2.** Use this operation within a range that satisfies the conditions above and the AC characteristics in the electrical specifications (see **CHAPTER 29 ELECTRICAL SPECIFICATIONS**).

**Remarks 1.**  $f_{\text{MCK}}$ : Operation clock frequency of target channel

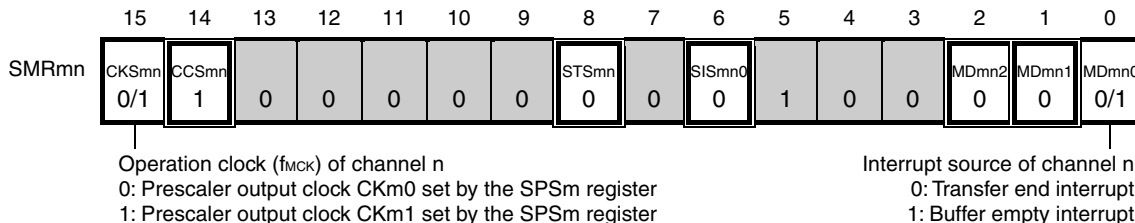
**2.** m: Unit number (m = 0, 1), n: Channel number (n = 0 to 3), mn = 00 to 03, 10 to 13



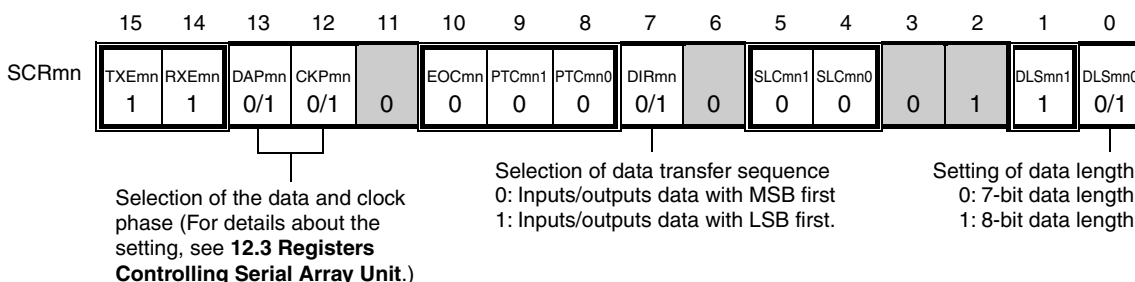
(1) Register setting

**Figure 12-64. Example of Contents of Registers for Slave Transmission/Reception of 3-Wire Serial I/O (CSI00, CSI01, CSI10, CSI11, CSI20, CSI21, CSI30, CSI31) (1/2)**

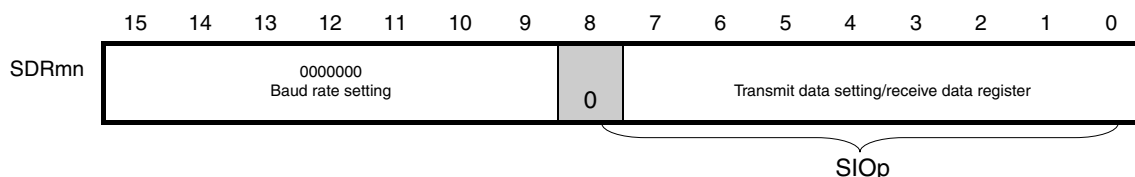
**(a) Serial mode register mn (SMRmn)**



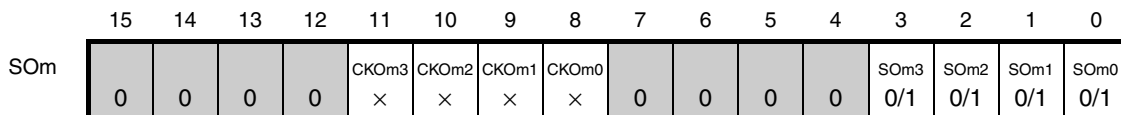
**(b) Serial communication operation setting register mn (SCRmn)**



**(c) Serial data register mn (SDRmn) (lower 8 bits: SIOp)**



**(d) Serial output register m (SOM) ... Sets only the bits of the target channel.**



**Caution** Be sure to set transmit data to the SIOp register before the clock from the master is started.

- Remarks**
- m: Unit number (m = 0, 1), n: Channel number (n = 0 to 3), p: CSI number (p = 00, 01, 10, 11, 20, 21, 30, 31), mn = 00 to 03, 10 to 13
  - : Setting is fixed in the CSI slave transmission/reception mode,  
 ■: Setting disabled (set to the initial value)  
 ×: Bit that cannot be used in this mode (set to the initial value when not used in any mode)  
 0/1: Set to 0 or 1 depending on the usage of the user

**Figure 12-64. Example of Contents of Registers for Slave Transmission/Reception of 3-Wire Serial I/O (CSI00, CSI01, CSI10, CSI11, CSI20, CSI21, CSI30, CSI31) (2/2)**

**(e) Serial output enable register m (SOEm) ... Sets only the bits of the target channel to 1.**

	15	14	13	12	11	10	9	8	7	6	5	4	3	2	1	0
SOEm	0	0	0	0	0	0	0	0	0	0	0	0	SOEm3 0/1	SOEm2 0/1	SOEm1 0/1	SOEm0 0/1

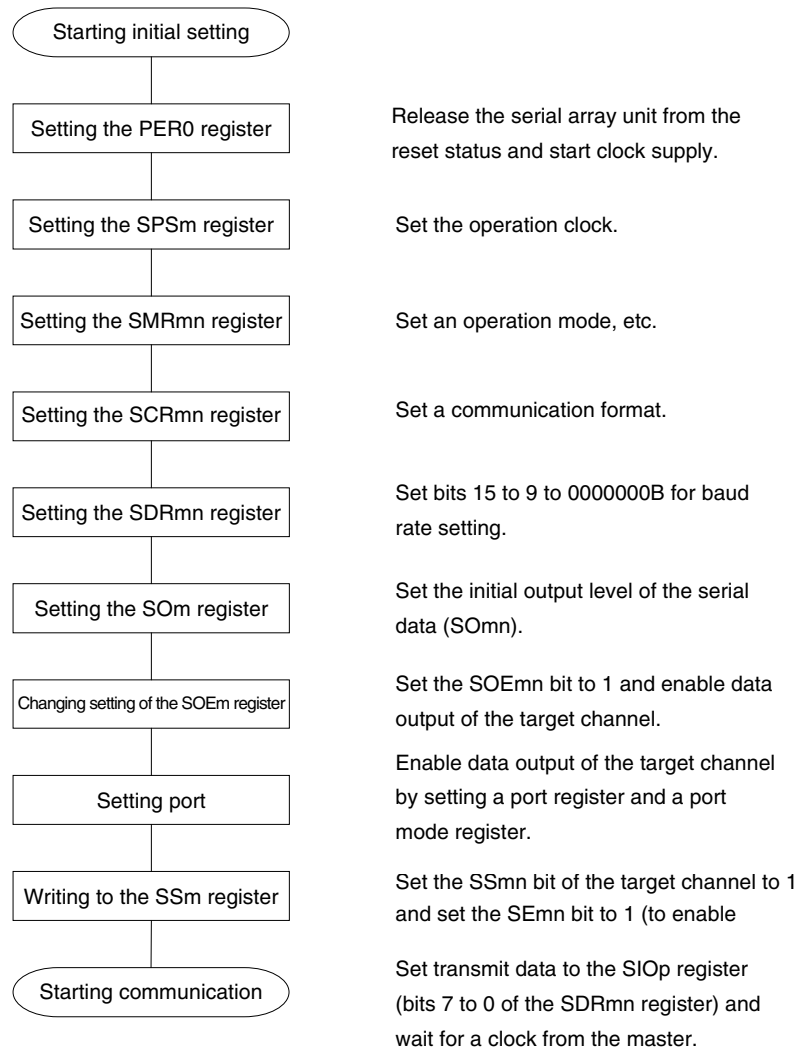
**(f) Serial channel start register m (SSm) ... Sets only the bits of the target channel to 1.**

	15	14	13	12	11	10	9	8	7	6	5	4	3	2	1	0
SSm	0	0	0	0	0	0	0	0	0	0	0	0	SSm3 0/1	SSm2 0/1	SSm1 0/1	SSm0 0/1

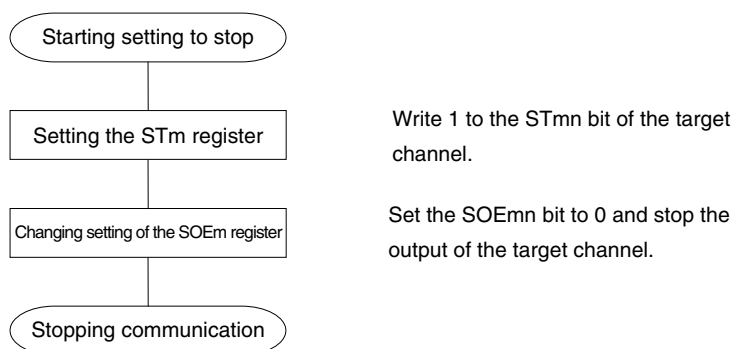
- Remarks**
1. m: Unit number (m = 0, 1), n: Channel number (n = 0 to 3), p: CSI number (p = 00, 01, 10, 11, 20, 21, 30, 31), mn = 00 to 03, 10 to 13
  2.  : Setting disabled (set to the initial value)  
 ×: Bit that cannot be used in this mode (set to the initial value when not used in any mode)  
 0/1: Set to 0 or 1 depending on the usage of the user

## (2) Operation procedure

Figure 12-65. Initial Setting Procedure for Slave Transmission/Reception

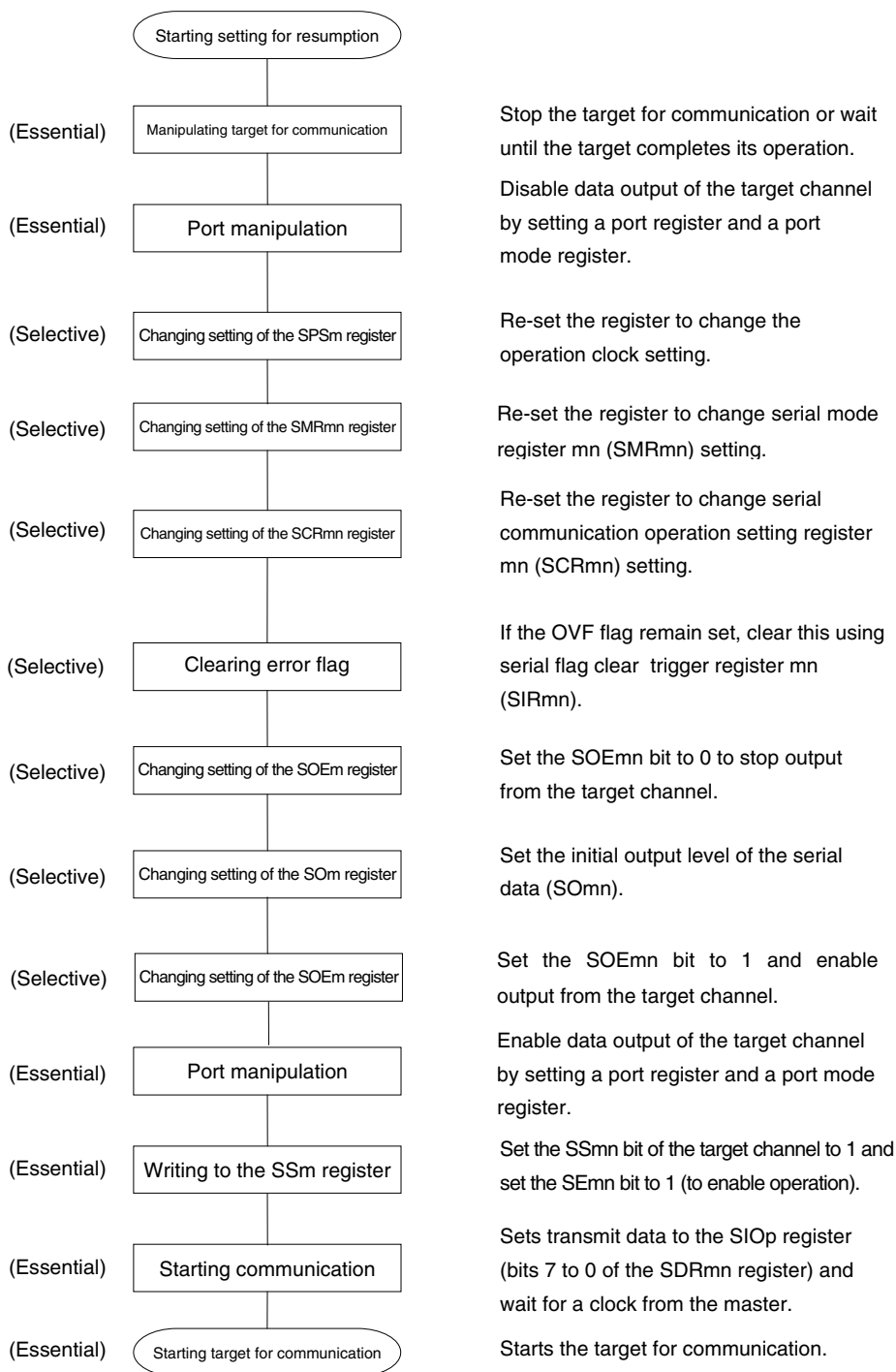


**Caution** Be sure to set transmit data to the SIOp register before the clock from the master is started.

**Figure 12-66. Procedure for Stopping Slave Transmission/Reception**

**Remark** Even after communication is stopped, the pin level is retained. To resume the operation, re-set serial output register m (SO<sub>m</sub>) (see **Figure 12-67 Procedure for Resuming Slave Transmission/Reception**).

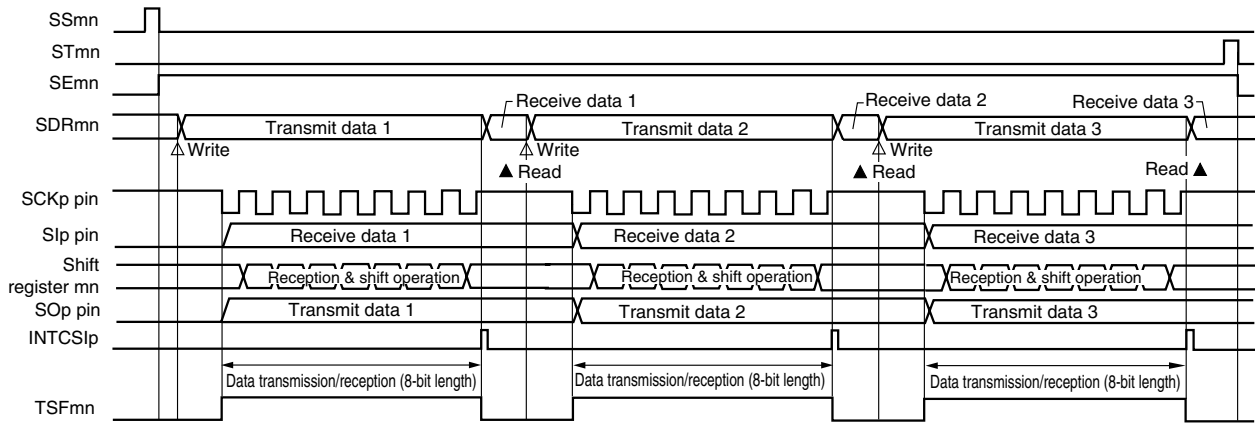
Figure 12-67. Procedure for Resuming Slave Transmission/Reception



**Caution** Be sure to set transmit data to the SIOp register before the clock from the master is started.

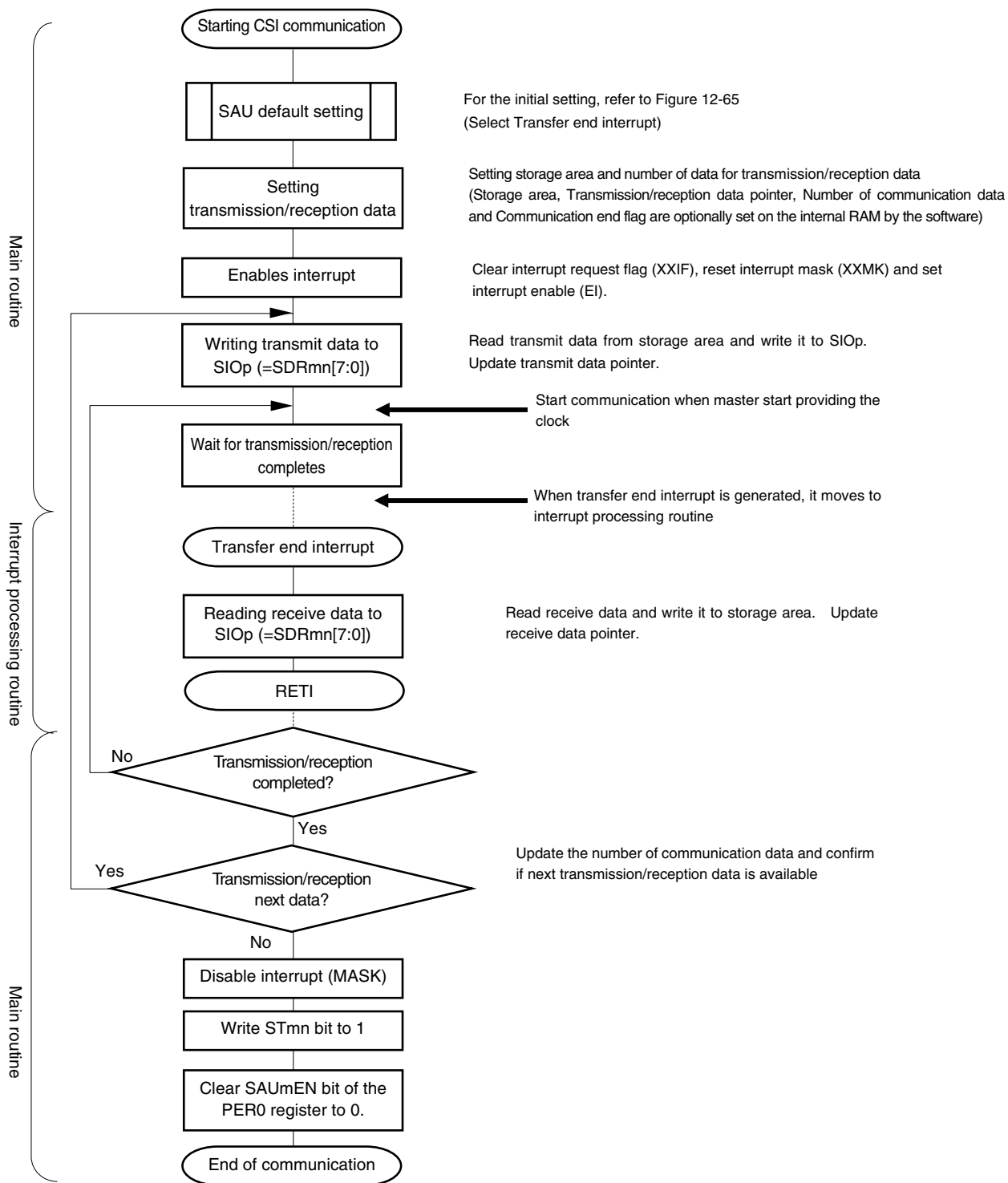
(3) Processing flow (in single-transmission/reception mode)

**Figure 12-68. Timing Chart of Slave Transmission/Reception (in Single-Transmission/Reception Mode)**  
 (Type 1: DAPmn = 0, CKPmn = 0)



**Remark** m: Unit number (m = 0, 1), n: Channel number (n = 0 to 3), p: CSI number (p = 00, 01, 10, 11, 20, 21, 30, 31), mn = 00 to 03, 10 to 13

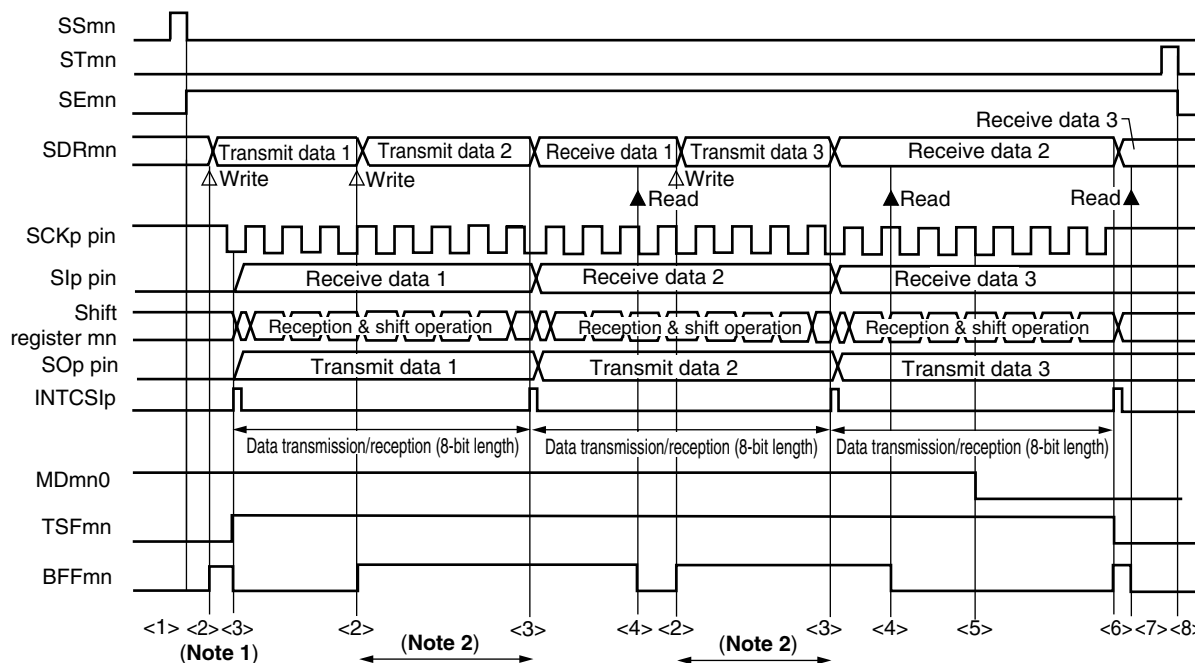
<R> **Figure 12-69. Flowchart of Slave Transmission/Reception (in Single-Transmission/Reception Mode)**



**Caution** Be sure to set transmit data to the SIOp register before the clock from the master is started.

(4) Processing flow (in continuous transmission/reception mode)

Figure 12-70. Timing Chart of Slave Transmission/Reception (in Continuous Transmission/Reception Mode) (Type 1: DAPmn = 0, CKPmn = 0)



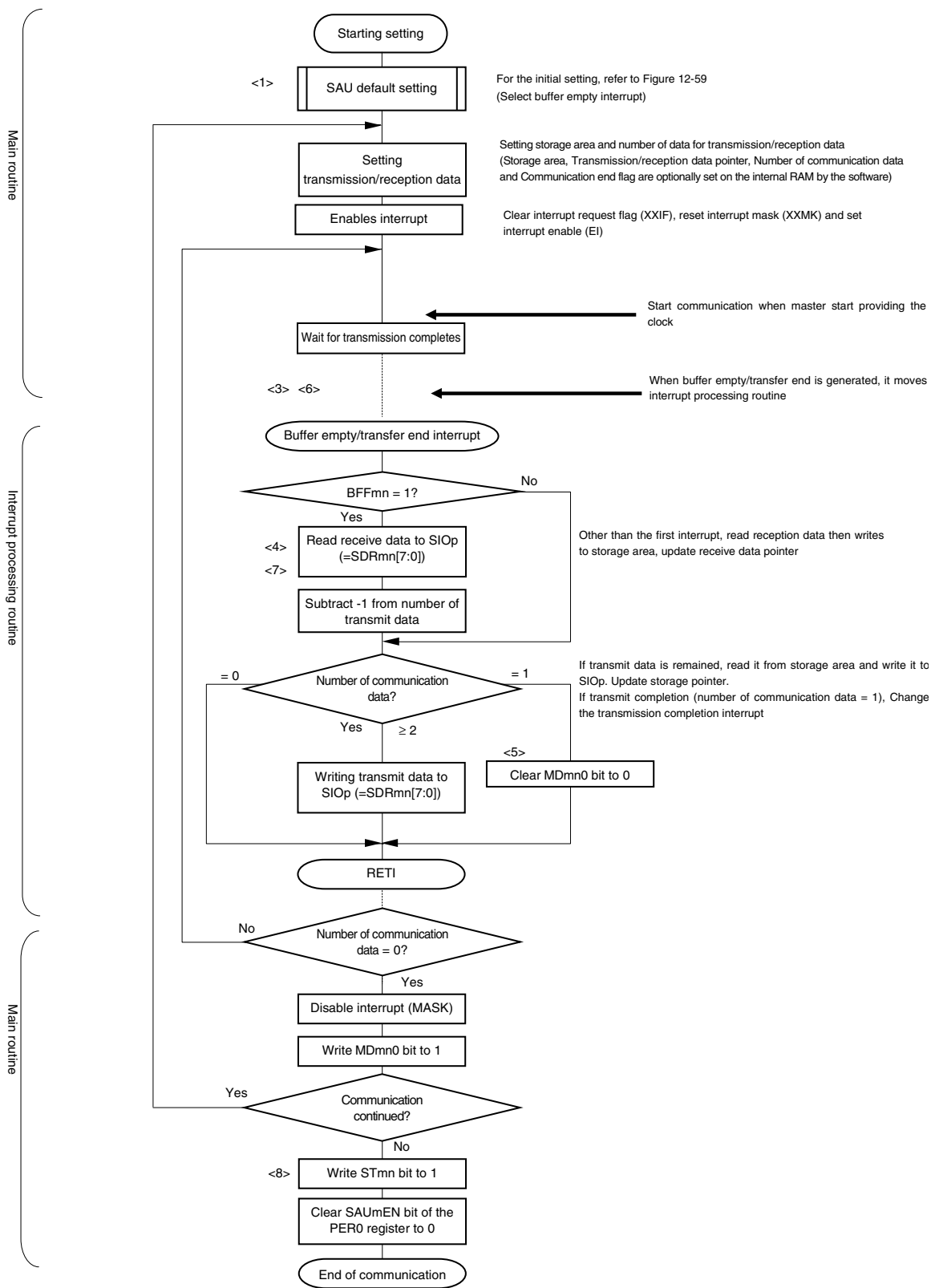
- Notes**
1. If transmit data is written to the SDRmn register while the BFFmn bit of serial status register mn (SSRmn) is 1 (valid data is stored in serial data register mn (SDRmn)), the transmit data is overwritten.
  2. The transmit data can be read by reading the SDRmn register during this period. At this time, the transfer operation is not affected.

**Caution** The MDmn0 bit of serial mode register mn (SMRmn) can be rewritten even during operation. However, rewrite it before transfer of the last bit is started, so that it has been rewritten before the transfer end interrupt of the last transmit data.

- Remarks**
1. <1> to <8> in the figure correspond to <1> to <8> in Figure 12-71 Flowchart of Slave Transmission/Reception (in Continuous Transmission/Reception Mode).
  2. m: Unit number (m = 0, 1), n: Channel number (n = 0 to 3), p: CSI number (p = 00, 01, 10, 11, 20, 21, 30, 31), mn = 00 to 03, 10 to 13



<R> **Figure 12-71. Flowchart of Slave Transmission/Reception (in Continuous Transmission/Reception Mode)**



**Caution** Be sure to set transmit data to the SIOp register before the clock from the master is started.

**Remark** <1> to <8> in the figure correspond to <1> to <8> in **Figure 12-70 Timing Chart of Slave Transmission/Reception (in Continuous Transmission/Reception Mode)**.

**12.5.7 SNOOZE mode function**

When  $\overline{SCKp}$  pin input is detected while in the STOP mode, the SNOOZE mode makes data reception that does not require the CPU possible. Only following CSIs can be specified for asynchronous reception.

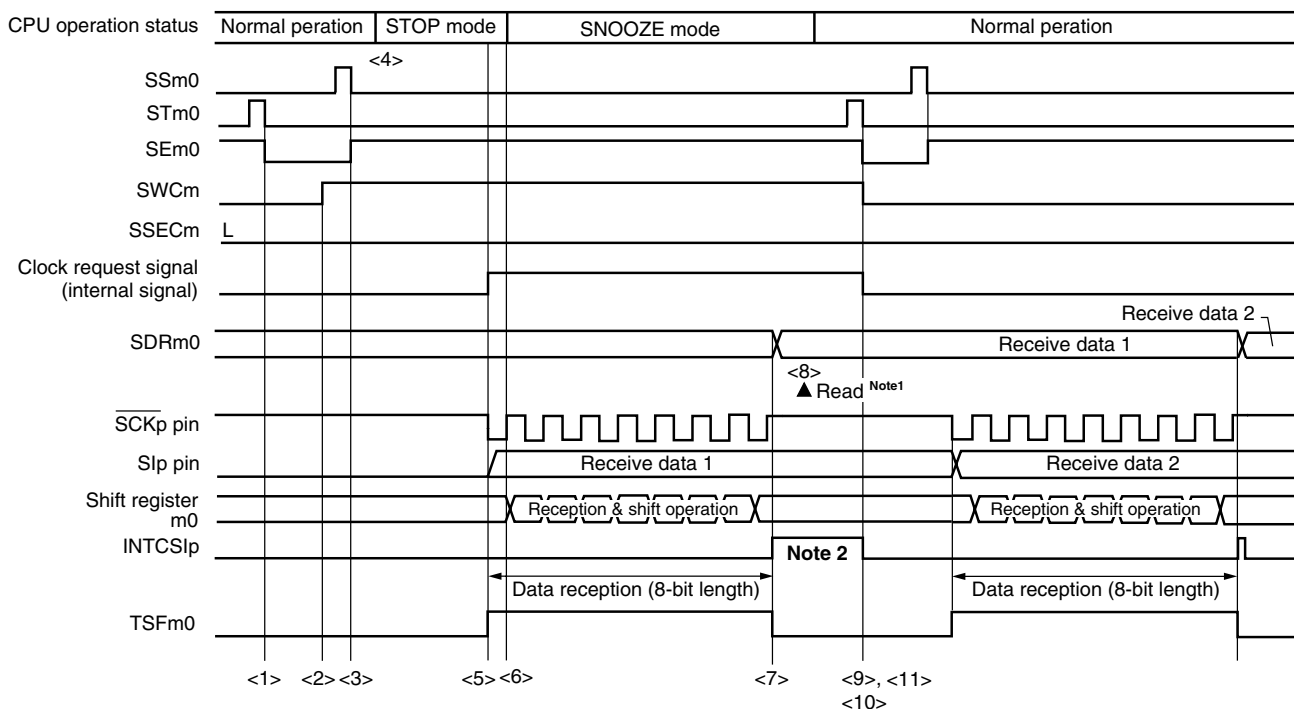
- <R>
- 24 to 64-pin products: CSI00
  - 80, 100, 128-pin products: CSI00 and CSI20

When using the SNOOZE mode function, set the SWCm bit of serial standby control register m (SSCm) to 1 before switching to the STOP mode.

- Cautions 1.** The SNOOZE mode can only be specified when the high-speed on-chip oscillator clock is selected for fCLK.
- 2.** The maximum transfer rate when using CSIp in the SNOOZE mode is 1 Mbps.

**(1) SNOOZE mode operation (once startup)**

**Figure 12-72. Timing Chart of SNOOZE Mode Operation (once startup) (Type 1: DAPmn = 0, CKPmn = 0)**



- Notes 1.** Only read received data while SWCm = 1 and before the next edge of the  $\overline{SCKp}$  pin input is detected.
- 2.** The transfer end interrupt (INTCSIp) is cleared either when SWCm is cleared to 0 or when the next edge of the  $\overline{SCKp}$  pin input is detected.

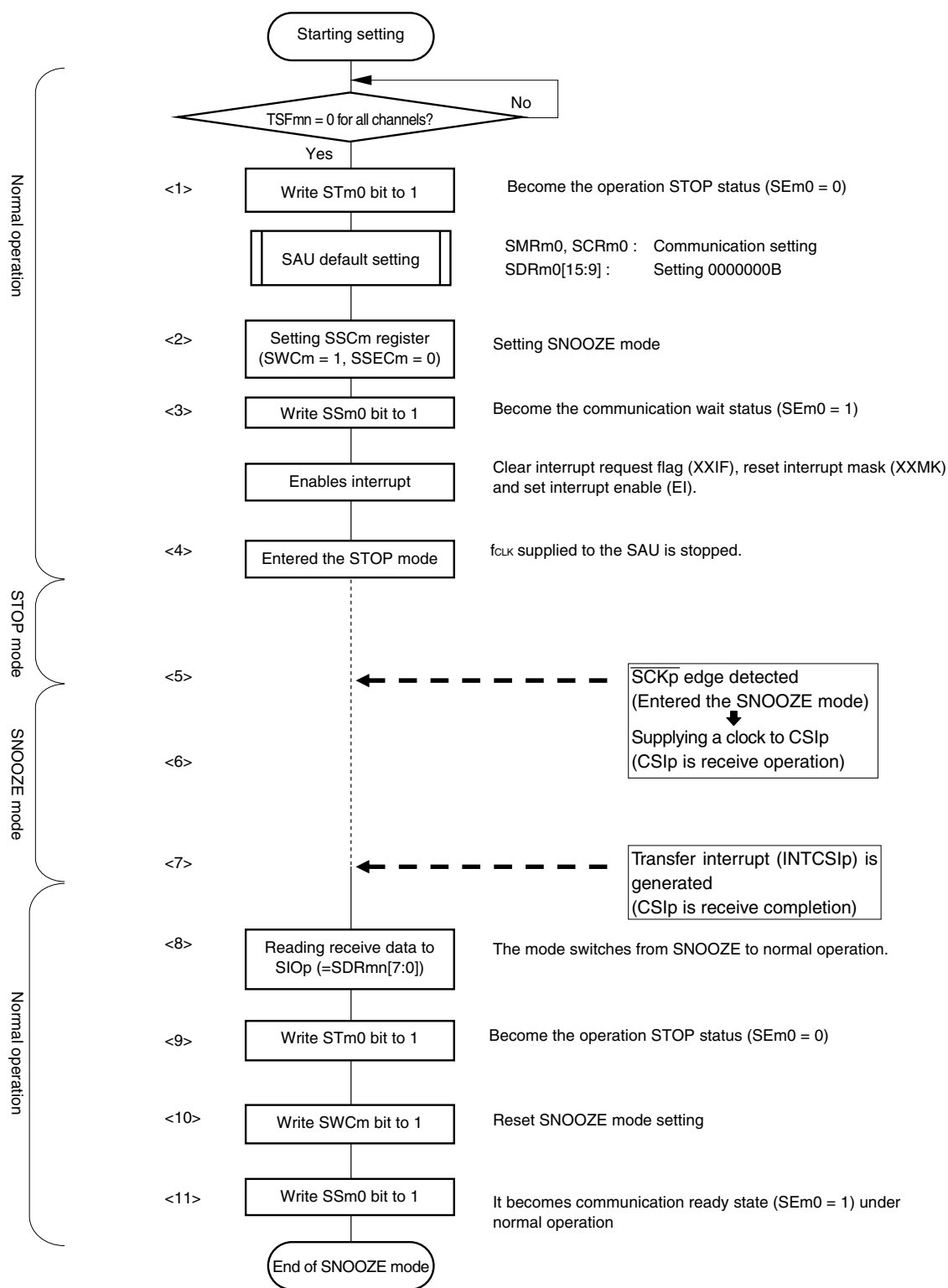
**Caution** Before switching to the SNOOZE mode or after reception operation in the SNOOZE mode finishes, be sure to set the STm0 bit to 1 and clear the SEm0 bit (to stop the operation).

**Remarks 1.** <1> to <11> in the figure correspond to <1> to <11> in Figure 12-73. Flowchart of SNOOZE Mode Operation (once startup).

- <R>
- 2.** 24 to 64-pin products: m = 0; p = 00
  - 80, 100, 128-pin products: m = 0, 1; p = 00, 20

<R>

Figure 12-73. Flowchart of SNOOZE Mode Operation (once startup)



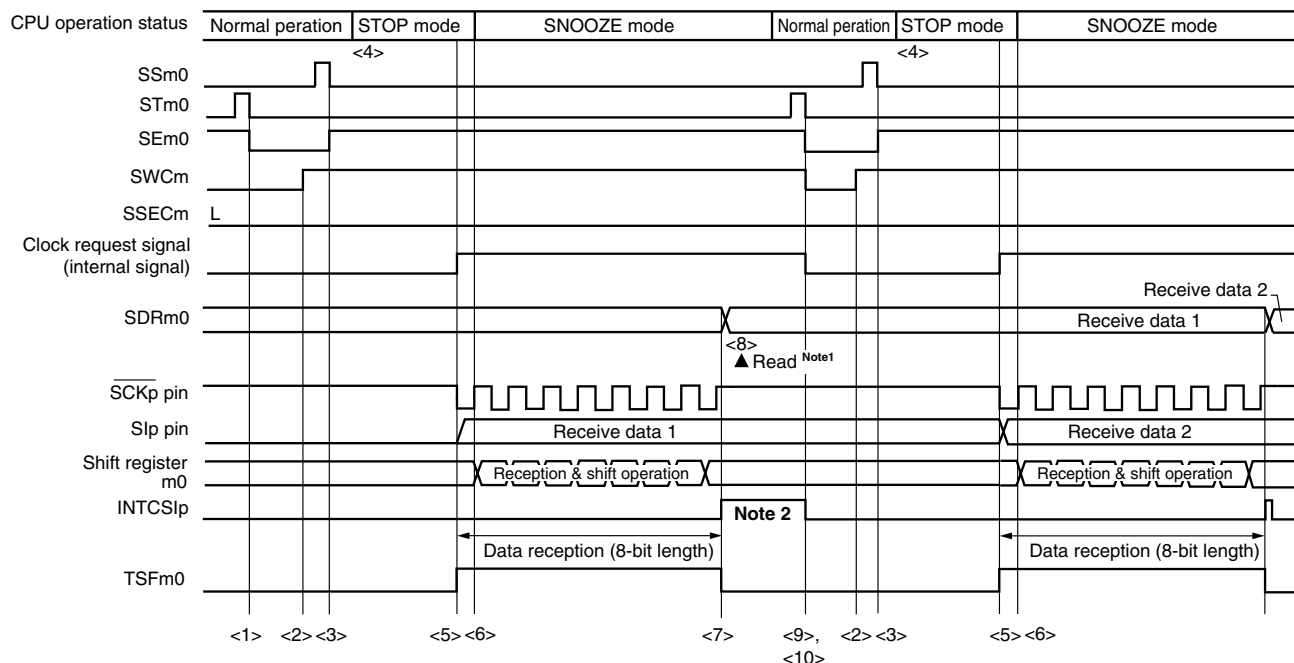
Remarks 1. <1> to <11> in the figure correspond to <1> to <11> in Figure 12-72. Timing Chart of SNOOZE Mode Operation (once startup).

<R>

- 2. 24 to 64-pin products: m = 0; p = 00
- 80, 100, 128-pin products: m = 0, 1; p = 00, 20

(2) SNOOZE mode operation (continuous startup)

Figure 12-74. Timing Chart of SNOOZE Mode Operation (continuous startup) (Type 1: DAPmn = 0, CKPmn = 0)



- Notes**
1. Only read received data while SWCm = 1 and before the next edge of the SCKp pin input is detected.
  2. The transfer end interrupt (INTCSlp) is cleared either when SWCm is cleared to 0 or when the next edge of the SCKp pin input is detected.

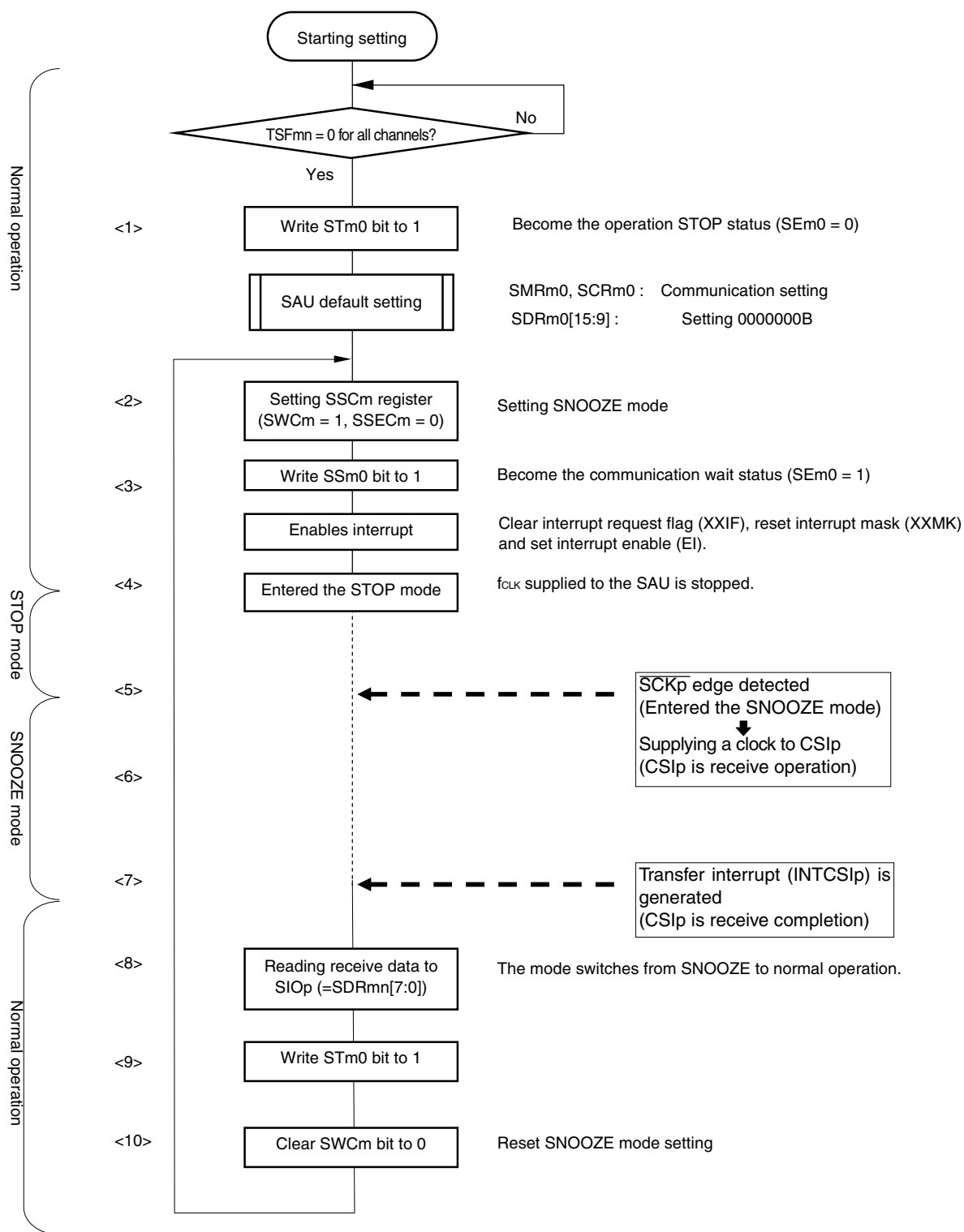
**Caution** Before switching to the SNOOZE mode or after reception operation in the SNOOZE mode finishes, be sure to set the STm0 bit to 1 and clear the SEm0 bit (to stop the operation).

**Remarks 1.** <1> to <10> in the figure correspond to <1> to <10> in Figure 12-75. Flowchart of SNOOZE Mode Operation (continuous startup).

- <R>
2. 24 to 64-pin products: m = 0; p = 00  
80, 100, 128-pin products: m = 0, 1; p = 00, 20

<R>

Figure 12-75. Flowchart of SNOOZE Mode Operation (continuous startup)



Remarks 1. <1> to <10> in the figure correspond to <1> to <10> in Figure 12-74. Timing Chart of SNOOZE Mode Operation (continuous startup).

<R>

- 2. 24 to 64-pin products: m = 0; p = 00
- 80, 100, 128-pin products: m = 0, 1; p = 00, 20

### 12.5.8 Calculating transfer clock frequency

The transfer clock frequency for 3-wire serial I/O (CSI00, CSI01, CSI10, CSI11, CSI20, CSI21, CSI30, CSI31) communication can be calculated by the following expressions.

#### (1) Master

$$(\text{Transfer clock frequency}) = \{ \text{Operation clock (f}_{\text{MCK}}) \text{ frequency of target channel} \} \div (\text{SDR}_{\text{mn}}[15:9] + 1) \div 2 \text{ [Hz]}$$

#### (2) Slave

$$(\text{Transfer clock frequency}) = \{ \text{Frequency of serial clock } (\overline{\text{SCK}}) \text{ supplied by master} \}^{\text{Note}} \text{ [Hz]}$$

**Note** The permissible maximum transfer clock frequency is  $f_{\text{MCK}}/6$ .

**Remark** The value of  $\text{SDR}_{\text{mn}}[15:9]$  is the value of bits 15 to 9 of serial data register  $\text{mn}$  ( $\text{SDR}_{\text{mn}}$ ) (0000000B to 1111111B) and therefore is 0 to 127.

The operation clock ( $f_{\text{MCK}}$ ) is determined by serial clock select register  $m$  ( $\text{SPS}_m$ ) and bit 15 ( $\text{CKS}_{\text{mn}}$ ) of serial mode register  $\text{mn}$  ( $\text{SMR}_{\text{mn}}$ ).

Table 12-2. Selection of Operation Clock For 3-Wire Serial I/O

SMRmn Register	SPSm Register								Operation Clock (f <sub>CLK</sub> ) <sup>Note</sup>	
	CKSmn	PRS m13	PRS m12	PRS m11	PRS m10	PRS m03	PRS m02	PRS m01	PRS m00	f <sub>CLK</sub> = 32 MHz
0	X	X	X	X	0	0	0	0	f <sub>CLK</sub>	32 MHz
	X	X	X	X	0	0	0	1	f <sub>CLK</sub> /2	16 MHz
	X	X	X	X	0	0	1	0	f <sub>CLK</sub> /2 <sup>2</sup>	8 MHz
	X	X	X	X	0	0	1	1	f <sub>CLK</sub> /2 <sup>3</sup>	4 MHz
	X	X	X	X	0	1	0	0	f <sub>CLK</sub> /2 <sup>4</sup>	2 MHz
	X	X	X	X	0	1	0	1	f <sub>CLK</sub> /2 <sup>5</sup>	1 MHz
	X	X	X	X	0	1	1	0	f <sub>CLK</sub> /2 <sup>6</sup>	500 kHz
	X	X	X	X	0	1	1	1	f <sub>CLK</sub> /2 <sup>7</sup>	250 kHz
	X	X	X	X	1	0	0	0	f <sub>CLK</sub> /2 <sup>8</sup>	125 kHz
	X	X	X	X	1	0	0	1	f <sub>CLK</sub> /2 <sup>9</sup>	62.5 kHz
	X	X	X	X	1	0	1	0	f <sub>CLK</sub> /2 <sup>10</sup>	31.25 kHz
	X	X	X	X	1	0	1	1	f <sub>CLK</sub> /2 <sup>11</sup>	15.63 kHz
1	0	0	0	0	X	X	X	X	f <sub>CLK</sub>	32 MHz
	0	0	0	1	X	X	X	X	f <sub>CLK</sub> /2	16 MHz
	0	0	1	0	X	X	X	X	f <sub>CLK</sub> /2 <sup>2</sup>	8 MHz
	0	0	1	1	X	X	X	X	f <sub>CLK</sub> /2 <sup>3</sup>	4 MHz
	0	1	0	0	X	X	X	X	f <sub>CLK</sub> /2 <sup>4</sup>	2 MHz
	0	1	0	1	X	X	X	X	f <sub>CLK</sub> /2 <sup>5</sup>	1 MHz
	0	1	1	0	X	X	X	X	f <sub>CLK</sub> /2 <sup>6</sup>	500 kHz
	0	1	1	1	X	X	X	X	f <sub>CLK</sub> /2 <sup>7</sup>	250 kHz
	1	0	0	0	X	X	X	X	f <sub>CLK</sub> /2 <sup>8</sup>	125 kHz
	1	0	0	1	X	X	X	X	f <sub>CLK</sub> /2 <sup>9</sup>	62.5 kHz
	1	0	1	0	X	X	X	X	f <sub>CLK</sub> /2 <sup>10</sup>	31.25 kHz
	1	0	1	1	X	X	X	X	f <sub>CLK</sub> /2 <sup>11</sup>	15.63 kHz
Other than above									Setting prohibited	

**Note** When changing the clock selected for f<sub>CLK</sub> (by changing the system clock control register (CKC) value), do so after having stopped (serial channel stop register m (STm) = 000FH) the operation of the serial array unit (SAU).

**Remarks 1.** X: Don't care

**2.** m: Unit number (m = 0, 1), n: Channel number (n = 0 to 3), mn = 00 to 03, 10 to 13

### 12.5.9 Procedure for processing errors that occurred during 3-wire serial I/O (CSI00, CSI01, CSI10, CSI11, CSI20, CSI21, CSI30, CSI31) communication

The procedure for processing errors that occurred during 3-wire serial I/O (CSI00, CSI01, CSI10, CSI11, CSI20, CSI21, CSI30, CSI31) communication is described in Figure 12-76.

**Figure 12-76. Processing Procedure in Case of Overrun Error**

Software Manipulation	Hardware Status	Remark
Reads serial data register mn (SDRmn).	→ The BFFmn bit of the SSRmn register is set to 0 and channel n is enabled to receive data.	This is to prevent an overrun error if the next reception is completed during error processing.
Reads serial status register mn (SSRmn).		Error type is identified and the read value is used to clear error flag.
Writes 1 to serial flag clear trigger register mn (SIRmn).	→ Error flag is cleared.	Error can be cleared only during reading, by writing the value read from the SSRmn register to the SIRmn register without modification.

**Remark** m: Unit number (m = 0, 1), n: Channel number (n = 0 to 3), mn = 00 to 03, 10 to 13



## 12.6 Operation of UART (UART0 to UART3) Communication

This is a start-stop synchronization function using two lines: serial data transmission (TxD) and serial data reception (RxD) lines. By using these two communication lines, each data frame, which consist of a start bit, data, parity bit, and stop bit, is transferred asynchronously (using the internal baud rate) between the microcontroller and the other communication party. Full-duplex UART communication can be performed by using a channel dedicated to transmission (even-numbered channel) and a channel dedicated to reception (odd-numbered channel). The LIN-bus can be implemented by using timer array unit 0 with an external interrupt (INTP0).

### [Data transmission/reception]

- Data length of 7, 8, or 9 bits <sup>Note</sup>
- Select the MSB/LSB first
- Level setting of transmit/receive data and select of reverse
- Parity bit appending and parity check functions
- Stop bit appending

### [Interrupt function]

- Transfer end interrupt/buffer empty interrupt
- Error interrupt in case of framing error, parity error, or overrun error

### [Error detection flag]

- Framing error, parity error, or overrun error

In addition, UART0 reception (channel 1 of unit 0) supports the SNOOZE mode. When RxD0 pin input is detected while in the STOP mode, the SNOOZE mode makes data reception that does not require the CPU possible. Only following UARTs can be specified for the reception baud rate adjustment function.

- <R>
- 24 to 64-pin products:        UART0
  - 80, 100, 128-pin products:    UART0 and UART2

The LIN-bus is accepted in UART2 (channels 0 and 1 of unit 1) (30, 32, 36, 40, 44, 48, 52, 64, 80, 100, and 128-pin products only).

### [LIN-bus functions]

- Wakeup signal detection
- Sync break field (SBF) detection
- Sync field measurement, baud rate calculation

} Using the external interrupt (INTP0) and timer array unit 0

**Note** Only following UARTs can be specified for the 9-bit data length.

- <R>
- 24 to 64-pin products:        UART0
  - 80, 100, 128-pin products:    UART0 and UART2

UART0 uses channels 0 and 1 of SAU0.

UART1 uses channels 2 and 3 of SAU0.

UART2 uses channels 0 and 1 of SAU1.

UART3 uses channels 2 and 3 of SAU1.

- 20, 24, and 25-pin products

Unit	Channel	Used as CSI	Used as UART	Used as Simplified I <sup>2</sup> C
0	0	CSI00	UART0 UART1	IIC00
	1	–		–
	2	–		–
	3	CSI11		IIC11
1	0	–	–	–
	1	–	–	–

- 30, 32-pin products

Unit	Channel	Used as CSI	Used as UART	Used as Simplified I <sup>2</sup> C
0	0	CSI00	UART0 UART1	IIC00
	1	–		–
	2	–		–
	3	CSI11		IIC11
1	0	CSI20	UART2 (supporting LIN-bus)	IIC20
	1	–		–

- 36, 40, 44-pin products

Unit	Channel	Used as CSI	Used as UART	Used as Simplified I <sup>2</sup> C
0	0	CSI00	UART0 UART1	IIC00
	1	–		–
	2	–		–
	3	CSI11		IIC11
1	0	CSI20	UART2 (supporting LIN-bus)	IIC20
	1	CSI21		IIC21

- 48, 52-pin products

Unit	Channel	Used as CSI	Used as UART	Used as Simplified I <sup>2</sup> C
0	0	CSI00	UART0 UART1	IIC00
	1	CSI01		IIC01
	2	–		–
	3	CSI11		IIC11
1	0	CSI20	UART2 (supporting LIN-bus)	IIC20
	1	CSI21		IIC21

- 64-pin products

Unit	Channel	Used as CSI	Used as UART	Used as Simplified I <sup>2</sup> C
0	0	CSI00	UART0	IIC00
	1	CSI01		IIC01
	2	CSI10	UART1	IIC10
	3	CSI11		IIC11
1	0	CSI20	UART2 (supporting LIN-bus)	IIC20
	1	CSI21		IIC21

- 80, 100, 128-pin products

Unit	Channel	Used as CSI	Used as UART	Used as Simplified I <sup>2</sup> C
0	0	CSI00	UART0	IIC00
	1	CSI01		IIC01
	2	CSI10	UART1	IIC10
	3	CSI11		IIC11
1	0	CSI20	UART2 (supporting LIN-bus)	IIC20
	1	CSI21		IIC21
	2	CSI30	UART3	IIC30
	3	CSI31		IIC31

**Caution** When using serial array unit as UARTs, the channels of both the transmitting side (even-number channel) and the receiving side (odd-number channel) can be used only as UARTs.

UART performs the following four types of communication operations.

- UART transmission (See 12.6.1.)
- UART reception (See 12.6.2.)
- LIN transmission (UART2 only) (See 12.7.1.)
- LIN reception (UART2 only) (See 12.7.2.)

### 12.6.1 UART transmission

UART transmission is an operation to transmit data from the RL78/G13 to another device asynchronously (start-stop synchronization).

Of two channels used for UART, the even channel is used for UART transmission.

UART	UART0	UART1	UART2	UART3
Target channel	Channel 0 of SAU0	Channel 2 of SAU0	Channel 0 of SAU1	Channel 2 of SAU1
Pins used	TxD0	TxD1	TxD2	TxD3
Interrupt	INTST0	INTST1	INTST2	INTST3
	Transfer end interrupt (in single-transfer mode) or buffer empty interrupt (in continuous transfer mode) can be selected.			
Error detection flag	None			
Transfer data length	7, 8, or 9 bits <sup>Note 1</sup>			
Transfer rate	Max. $f_{MCK}/6$ [bps] (SDR <sub>mn</sub> [15:9] = 3 or more), Min. $f_{CLK}/(2 \times 2^{15} \times 128)$ [bps] <sup>Note 2</sup>			
Data phase	Forward output (default: high level) Reverse output (default: low level)			
Parity bit	The following selectable <ul style="list-style-type: none"> <li>• No parity bit</li> <li>• Appending 0 parity</li> <li>• Appending even parity</li> <li>• Appending odd parity</li> </ul>			
Stop bit	The following selectable <ul style="list-style-type: none"> <li>• Appending 1 bit</li> <li>• Appending 2 bits</li> </ul>			
Data direction	MSB or LSB first			

**Notes 1.** Only following UARTs can be specified for the 9-bit data length.

- 24 to 64-pin products: UART0
- 80, 100, 128-pin products: UART0 and UART2

**2.** Use this operation within a range that satisfies the conditions above and the AC characteristics in the electrical specifications (see **CHAPTER 29 ELECTRICAL SPECIFICATIONS**).

**Remarks 1.**  $f_{MCK}$ : Operation clock frequency of target channel

$f_{CLK}$ : System clock frequency

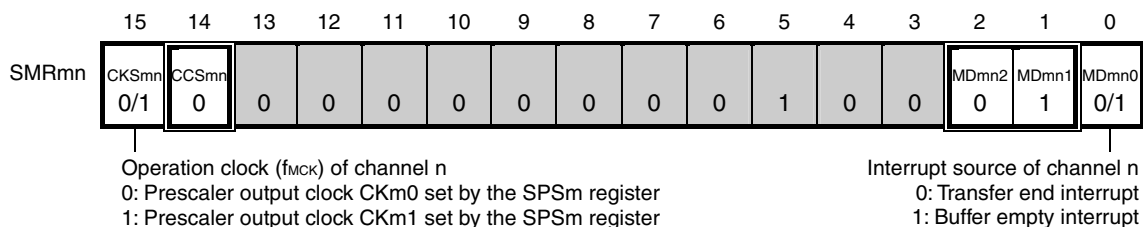
**2.** m: Unit number (m = 0, 1), n: Channel number (n = 0, 2), mn = 00, 02, 10, 12

<R>

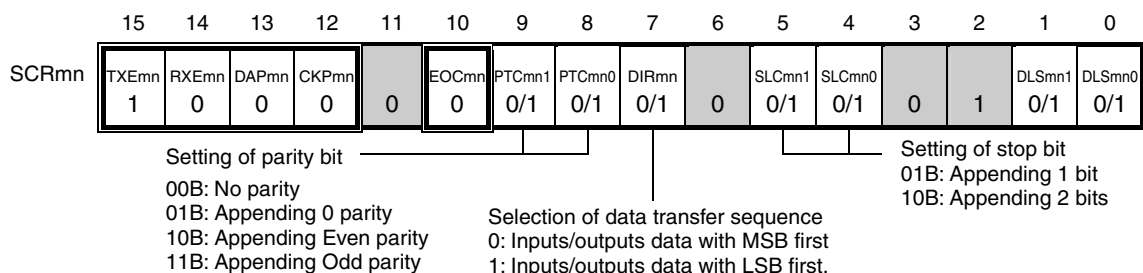
(1) Register setting

Figure 12-77. Example of Contents of Registers for UART Transmission of UART (UART0 to UART3) (1/2)

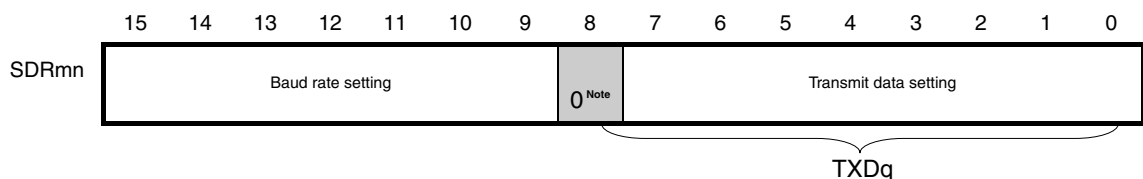
(a) Serial mode register mn (SMRmn)



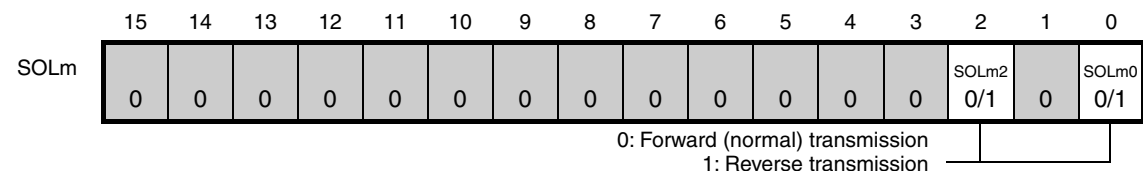
(b) Serial communication operation setting register mn (SCRmn)



(c) Serial data register mn (SDRmn) (lower 8 bits: TXDq)



(d) Serial output level register m (SOLm) ... Sets only the bits of the target channel.



**Note** When UART0 performs 9-bit communication (by setting the DLS001 and DLS000 bits of the SCR00 register to 1), bits 0 to 8 of the SDR00 register are used as the transmission data specification area. Only following UARTs can be specified for the 9-bit data length.

<R>

- 24 to 64-pin products:      UART0
- 80, 100, 128-pin products:  UART0 and UART2

- Remarks 1.** m: Unit number (m = 0, 1), n: Channel number (n = 0, 2), q: UART number (q = 0 to 3), mn = 00, 02, 10, 12
- 2.**  : Setting is fixed in the UART transmission mode,  : Setting disabled (set to the initial value)  
 ×: Bit that cannot be used in this mode (set to the initial value when not used in any mode)  
 0/1: Set to 0 or 1 depending on the usage of the user

**Figure 12-77. Example of Contents of Registers for UART Transmission of UART (UART0 to UART3) (2/2)**

**(e) Serial output register m (SOm) ... Sets only the bits of the target channel.**

	15	14	13	12	11	10	9	8	7	6	5	4	3	2	1	0
SOm	0	0	0	0	CKOm3	CKOm2	CKOm1	CKOm0	0	0	0	0	Som3	SOm2	SOm1	SOm0
					×	×	×	×					×	0/1 <sup>Note</sup>	×	0/1 <sup>Note</sup>

0: Serial data output value is "0"  
 1: Serial data output value is "1"

**(f) Serial output enable register m (SOEm) ... Sets only the bits of the target channel to 1.**

	15	14	13	12	11	10	9	8	7	6	5	4	3	2	1	0
SOEm	0	0	0	0	0	0	0	0	0	0	0	0	SOEm3	SOEm2	SOEm1	SOEm0
													×	0/1	×	0/1

**(g) Serial channel start register m (SSm) ... Sets only the bits of the target channel to 1.**

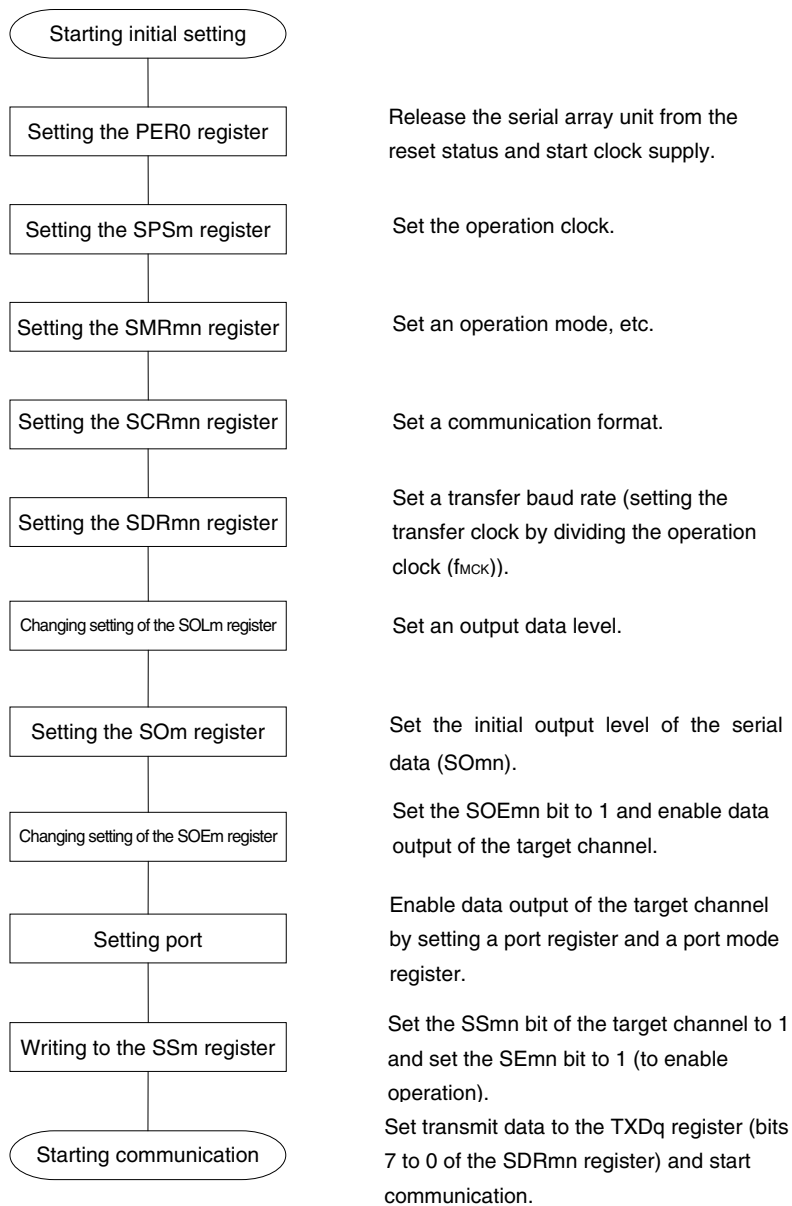
	15	14	13	12	11	10	9	8	7	6	5	4	3	2	1	0
SSm	0	0	0	0	0	0	0	0	0	0	0	0	SSm3	SSm2	SSm1	SSm0
													×	0/1	×	0/1

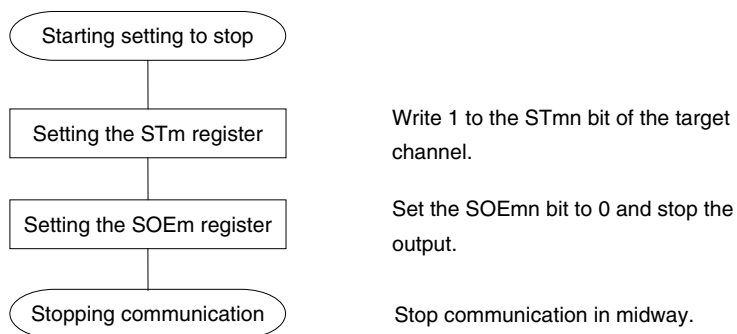
**Note** Before transmission is started, be sure to set to 1 when the SOLmn bit of the target channel is set to 0, and set to 0 when the SOLmn bit of the target channel is set to 1. The value varies depending on the communication data during communication operation.

- Remarks**
- m: Unit number (m = 0, 1), n: Channel number (n = 0, 2), q: UART number (q = 0 to 3)  
 mn = 00, 02, 10, 12
  - : Setting disabled (set to the initial value)
    - ×: Bit that cannot be used in this mode (set to the initial value when not used in any mode)
    - 0/1: Set to 0 or 1 depending on the usage of the user

## (2) Operation procedure

Figure 12-78. Initial Setting Procedure for UART Transmission

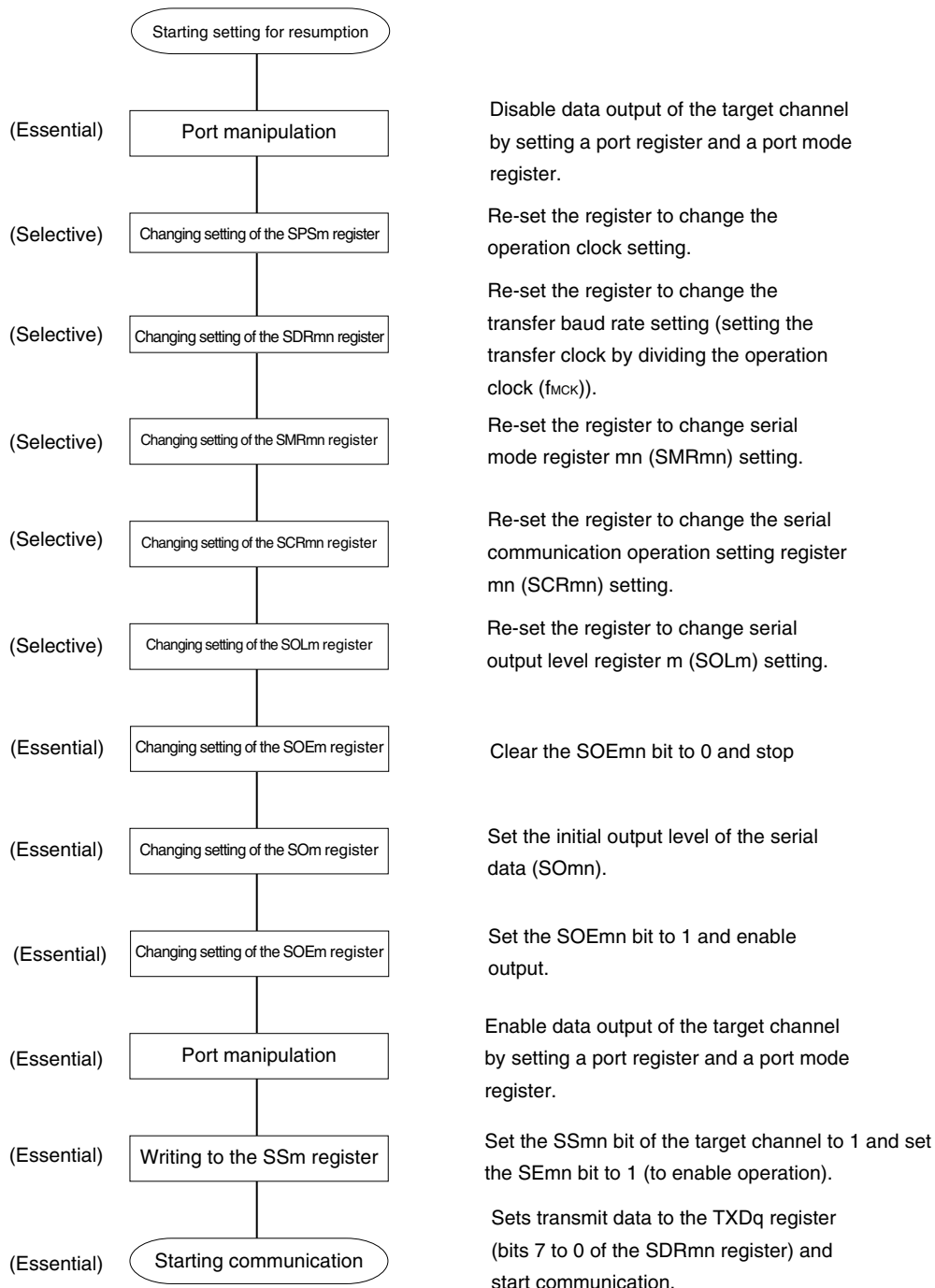


**Figure 12-79. Procedure for Stopping UART Transmission**

**Remark** Even after communication is stopped, the pin level is retained. To resume the operation, re-set serial output register m (SOM) (see **Figure 12-80 Procedure for Resuming UART Transmission**).

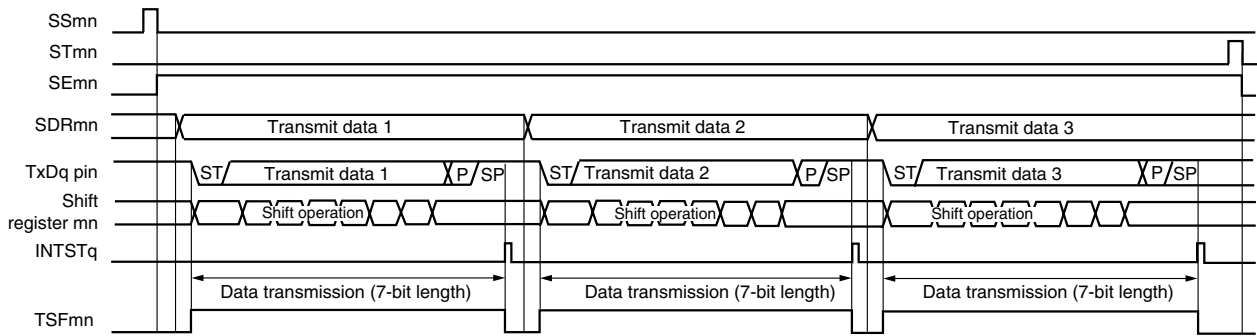


**Figure 12-80. Procedure for Resuming UART Transmission**



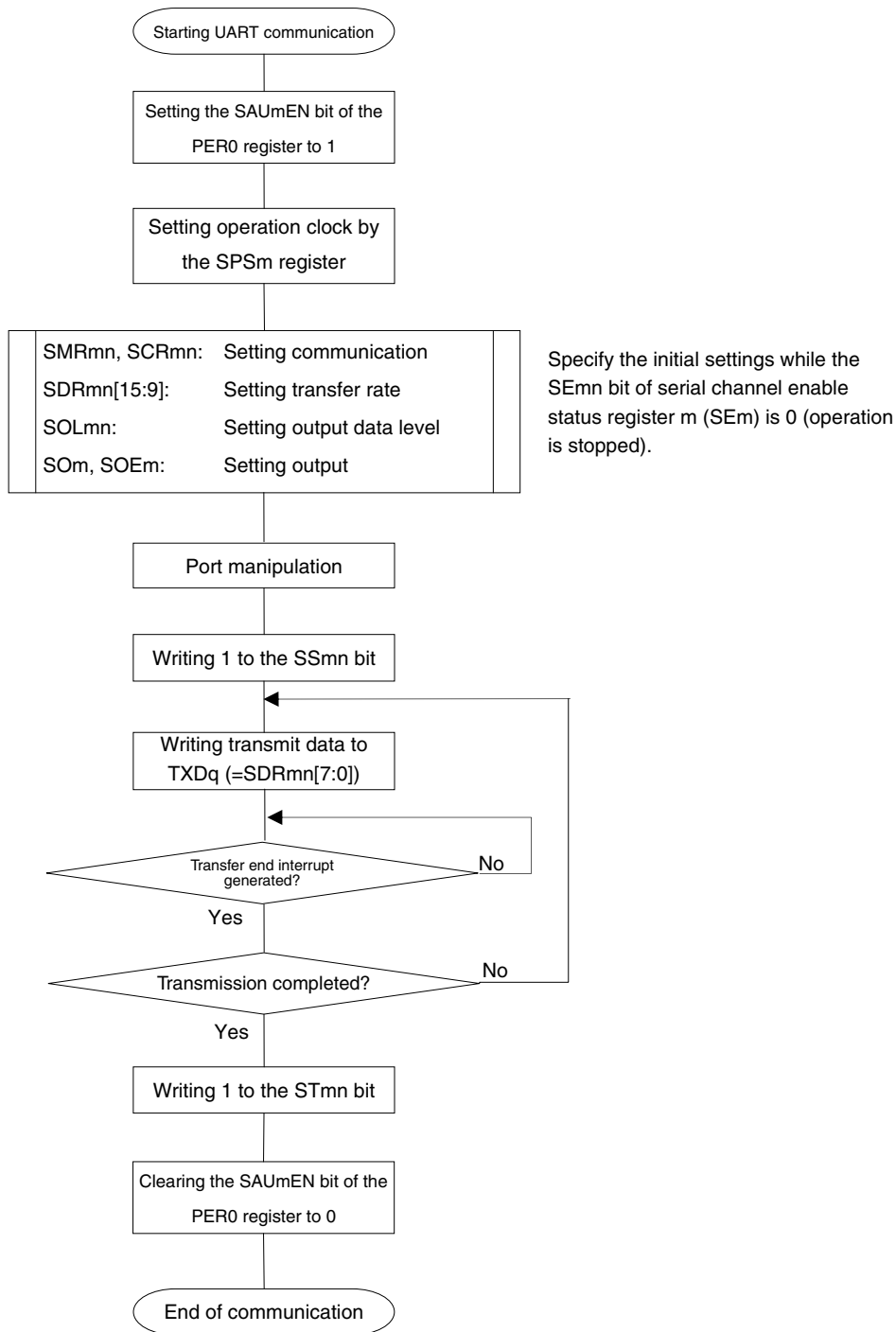
(3) Processing flow (in single-transmission mode)

Figure 12-81. Timing Chart of UART Transmission (in Single-Transmission Mode)



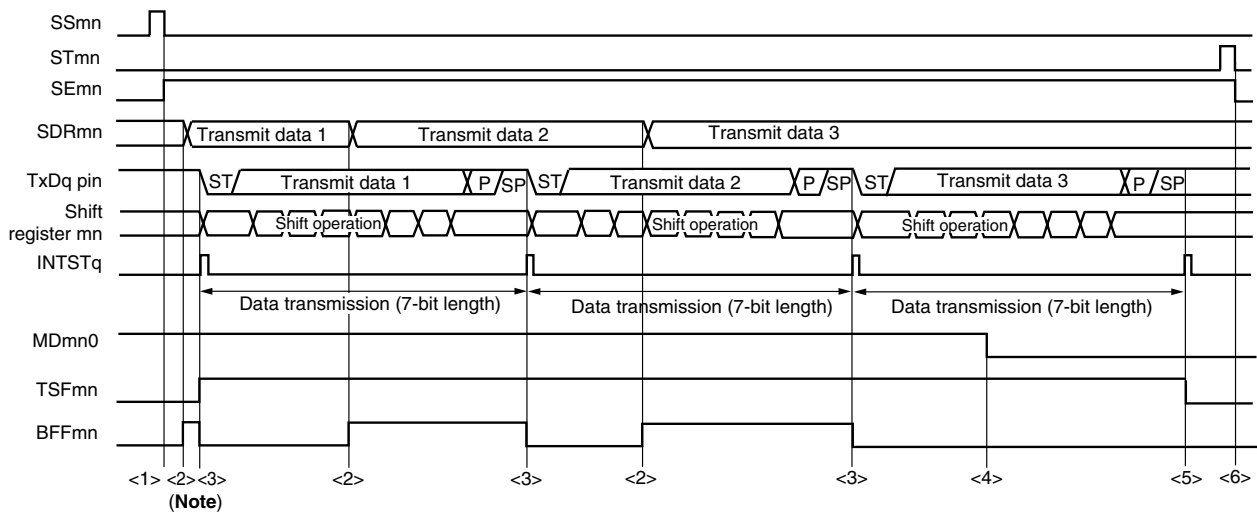
**Remark** m: Unit number (m = 0, 1), n: Channel number (n = 0, 2), q: UART number (q = 0 to 3)  
 mn = 00, 02, 10, 12

Figure 12-82. Flowchart of UART Transmission (in Single-Transmission Mode)



(4) Processing flow (in continuous transmission mode)

Figure 12-83. Timing Chart of UART Transmission (in Continuous Transmission Mode)

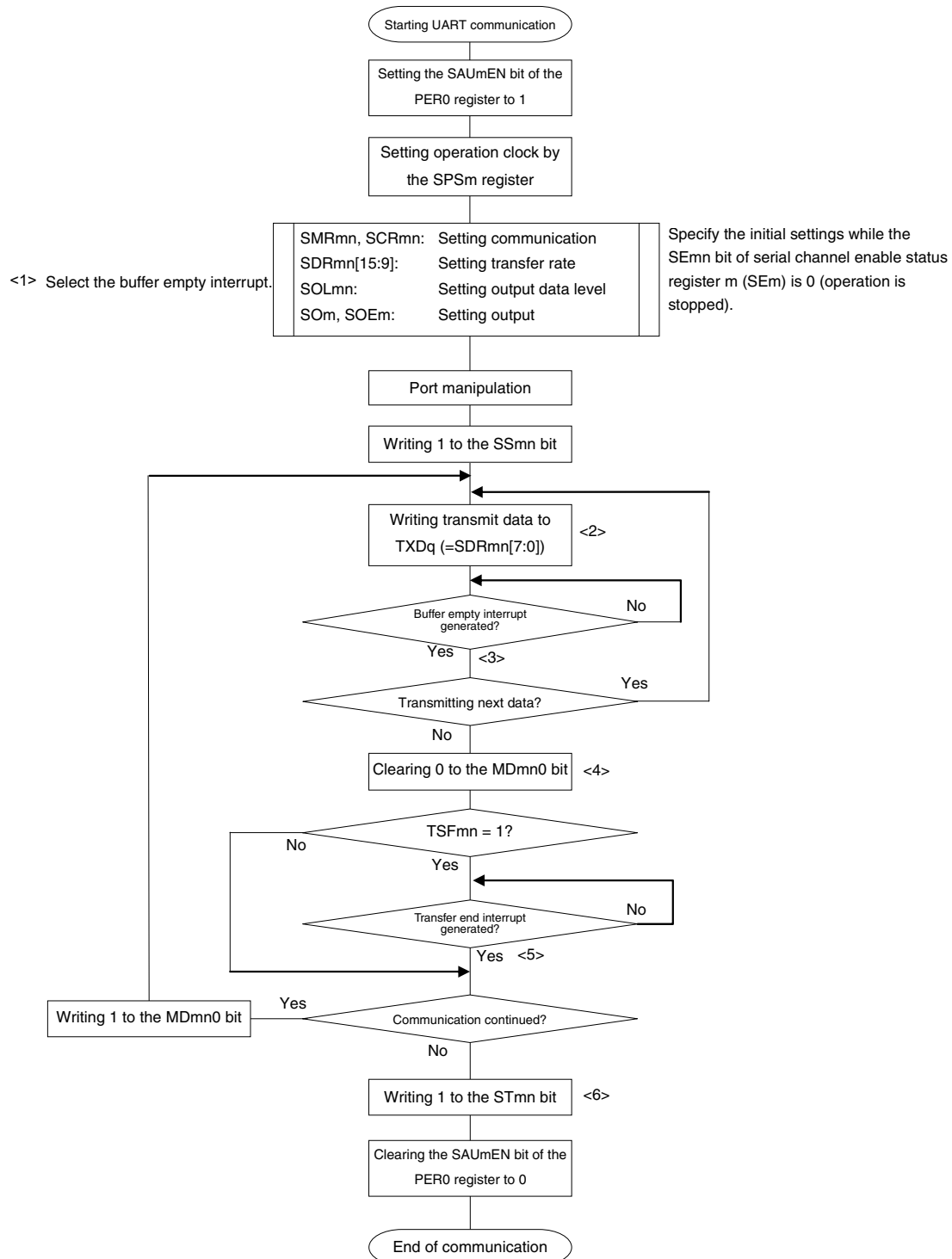


**Note** If transmit data is written to the SDRmn register while the BFFmn bit of serial status register mn (SSRmn) is 1 (valid data is stored in serial data register mn (SDRmn)), the transmit data is overwritten.

**Caution** The MDmn0 bit of serial mode register mn (SSRmn) can be rewritten even during operation. However, rewrite it before transfer of the last bit is started, so that it will be rewritten before the transfer end interrupt of the last transmit data.

**Remark** m: Unit number (m = 0, 1), n: Channel number (n = 0, 2), q: UART number (q = 0 to 3)  
mn = 00, 02, 10, 12

Figure 12-84. Flowchart of UART Transmission (in Continuous Transmission Mode)



**Remark** <1> to <6> in the figure correspond to <1> to <6> in **Figure 12-83 Timing Chart of UART Transmission (in Continuous Transmission Mode)**.

### 12.6.2 UART reception

UART reception is an operation wherein the RL78/G13 asynchronously receives data from another device (start-stop synchronization).

For UART reception, the odd-number channel of the two channels used for UART is used. The SMR register of both the odd- and even-numbered channels must be set.

UART	UART0	UART1	UART2	UART3
Target channel	Channel 1 of SAU0	Channel 3 of SAU0	Channel 1 of SAU1	Channel 3 of SAU1
Pins used	RxD0	RxD1	RxD2	RxD3
Interrupt	INTSR0	INTSR1	INTSR2	INTSR3
	Transfer end interrupt only (Setting the buffer empty interrupt is prohibited.)			
Error interrupt	INTSRE0	INTSRE1	INTSRE2	INTSRE3
Error detection flag	<ul style="list-style-type: none"> <li>Framing error detection flag (FEFmn)</li> <li>Parity error detection flag (PEFmn)</li> <li>Overrun error detection flag (OVFmn)</li> </ul>			
Transfer data length	7, 8 or 9 bits <sup>Note 1</sup>			
Transfer rate	Max. $f_{MCK}/6$ [bps] (SDRmn [15:9] = 3 or more), Min. $f_{CLK}/(2 \times 2^{15} \times 128)$ [bps] <sup>Note 2</sup>			
Data phase	Forward output (default: high level) Reverse output (default: low level)			
Parity bit	The following selectable <ul style="list-style-type: none"> <li>No parity bit (no parity check)</li> <li>Appending 0 parity (no parity check)</li> <li>Appending even parity</li> <li>Appending odd parity</li> </ul>			
Stop bit	Appending 1 bit			
Data direction	MSB or LSB first			

**Notes 1.** Only following UARTs can be specified for the 8-bit data length.

<R>

- 24 to 64-pin products: UART0 only
- 80, 100, 128-pin products: UART0 and UART2 only

**2.** Use this operation within a range that satisfies the conditions above and the AC characteristics in the electrical specifications (see **CHAPTER 29 ELECTRICAL SPECIFICATIONS**).

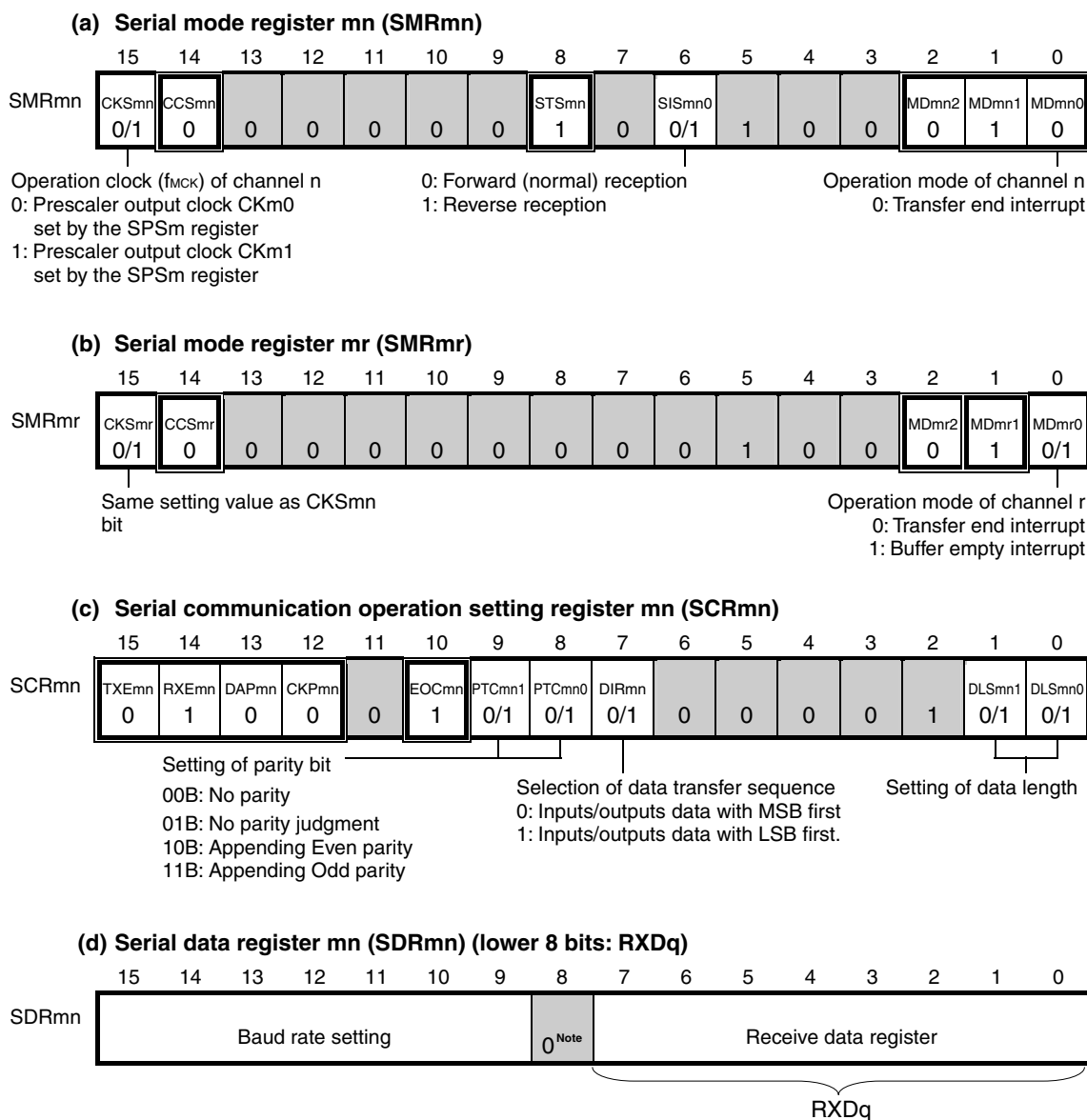
**Remarks 1.**  $f_{MCK}$ : Operation clock frequency of target channel

$f_{CLK}$ : System clock frequency

**2.** m: Unit number (m = 0, 1), n: Channel number (n = 1, 3), mn = 01, 03, 11, 13

(1) Register setting

Figure 12-85. Example of Contents of Registers for UART Reception of UART (UART0 to UART3) (1/2)



**Note** When UART performs 9-bit communication, bits 0 to 8 of the SDRm1 register are used as the transmission data specification area. Only following UARTs can be specified for the 8-bit data length.

<R>

- 24 to 64-pin products: UART0
- 80, 100, 128-pin products: UART0 and UART2

**Caution** For the UART reception, be sure to set the SMRmr register of channel r to UART transmission mode that is to be paired with channel n.

**Remarks 1.** m: Unit number (m = 0, 1), n: Channel number (n = 1, 3), mn = 01, 03, 11, 13  
 r: Channel number (r = n - 1), q: UART number (q = 0 to 3)

2. □: Setting is fixed in the UART reception mode, ■: Setting disabled (set to the initial value)  
 ×: Bit that cannot be used in this mode (set to the initial value when not used in any mode)  
 0/1: Set to 0 or 1 depending on the usage of the user

**Figure 12-85. Example of Contents of Registers for UART Reception of UART (UART0 to UART3) (2/2)**

(e) Serial output register m (SOm) ... The register that not used in this mode.

	15	14	13	12	11	10	9	8	7	6	5	4	3	2	1	0
SOm					CKOm3	CKOm2	CKOm1	CKOm0					SOm3	SOm2	SOm1	SOm0
	0	0	0	0	×	×	×	×	0	0	0	0	×	×	×	×

(f) Serial output enable register m (SOEm) ...The register that not used in this mode.

	15	14	13	12	11	10	9	8	7	6	5	4	3	2	1	0
SOEm													SOEm3	SOEm2	SOEm1	SOEm0
	0	0	0	0	0	0	0	0	0	0	0	0	×	×	×	×

(g) Serial channel start register m (SSm) ... Sets only the bits of the target channel is 1.

	15	14	13	12	11	10	9	8	7	6	5	4	3	2	1	0
SSm													SSm3	SSm2	SSm1	SSm0
	0	0	0	0	0	0	0	0	0	0	0	0	0/1	×	0/1	×

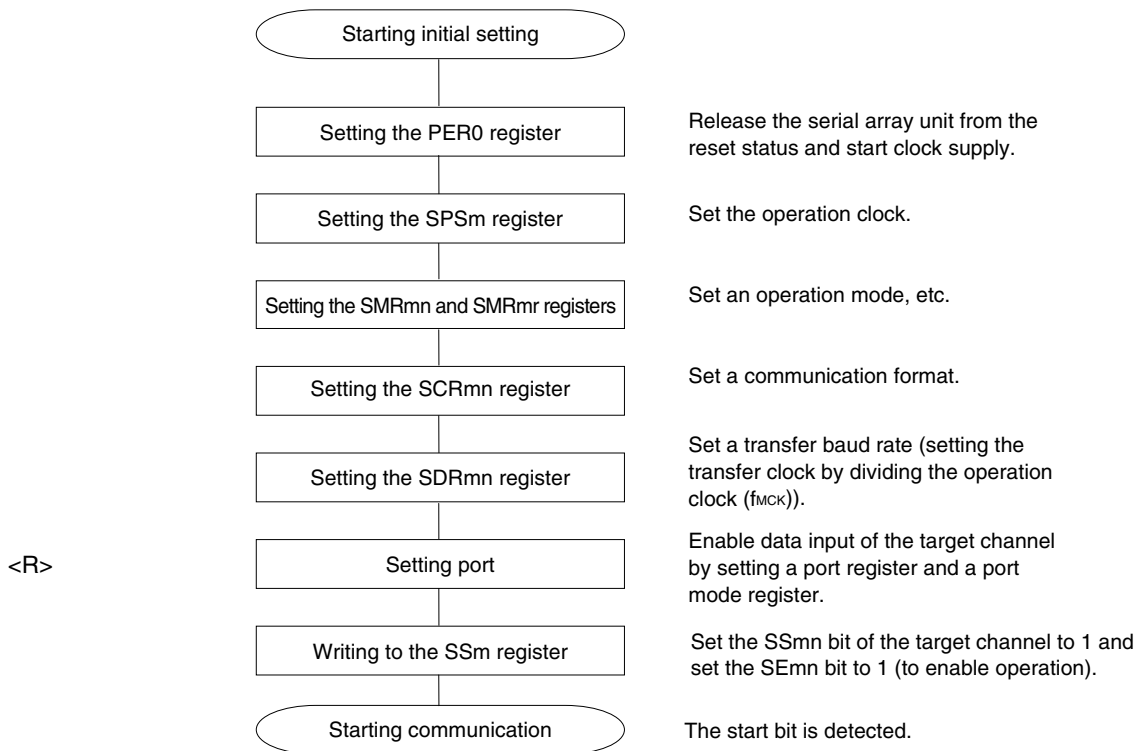
**Caution** For the UART reception, be sure to set the SMRmr register of channel r to UART Transmission mode that is to be paired with channel n.

- Remarks**
- m: Unit number (m = 0, 1), n: Channel number (n = 1, 3), mn = 01, 03, 11, 13  
r: Channel number (r = n - 1), q: UART number (q = 0 to 3)
  - ☐: Setting is fixed in the UART reception mode, □: Setting disabled (set to the initial value)  
×: Bit that cannot be used in this mode (set to the initial value when not used in any mode)  
0/1: Set to 0 or 1 depending on the usage of the user



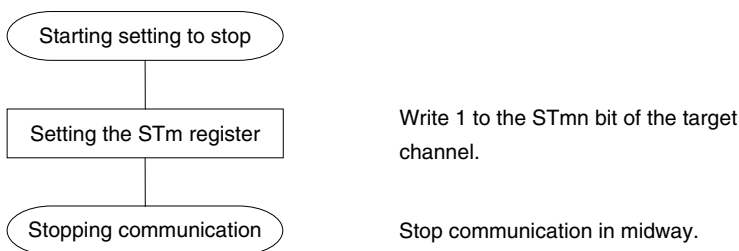
(2) Operation procedure

Figure 12-86. Initial Setting Procedure for UART Reception

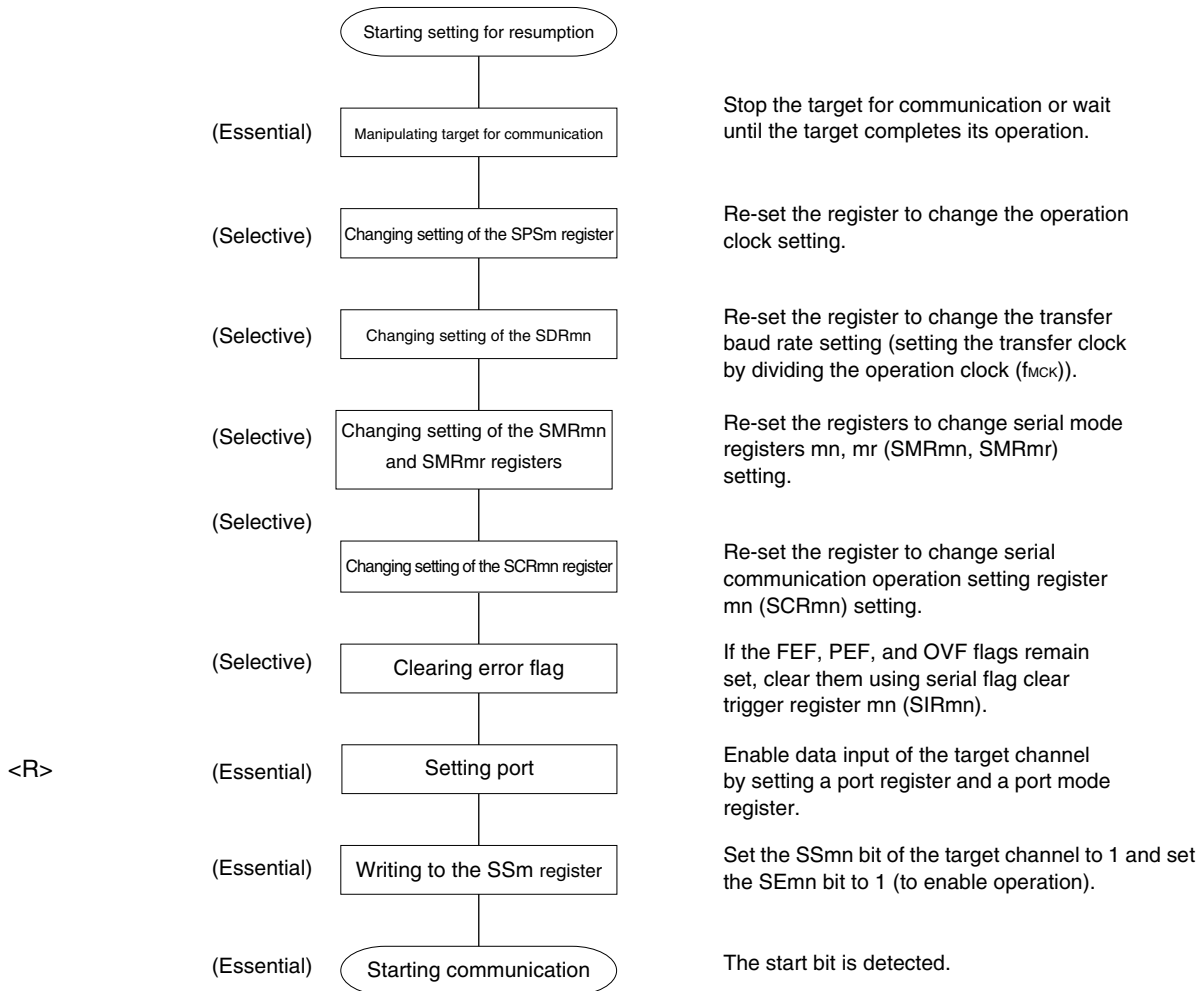


**Caution** Set the RXEmn bit of SCRmn register to 1, and then be sure to set SSmn to 1 after 4 or more fCLK clocks have elapsed.

Figure 12-87. Procedure for Stopping UART Reception

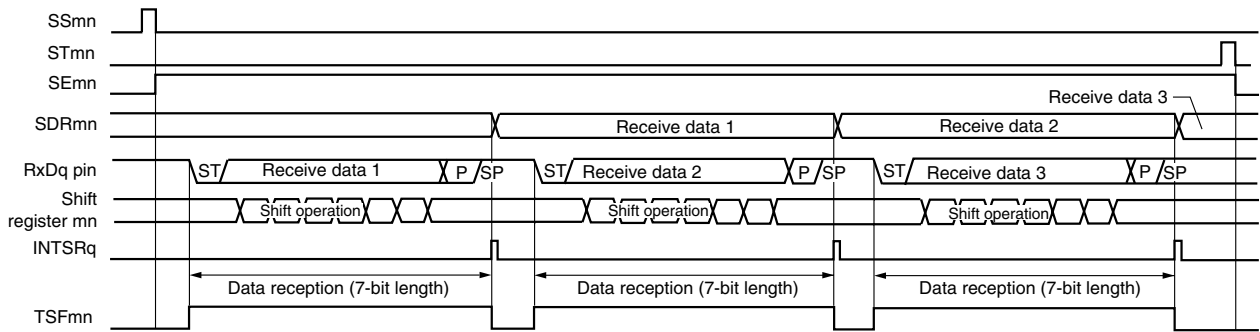


**Figure 12-88. Procedure for Resuming UART Reception**



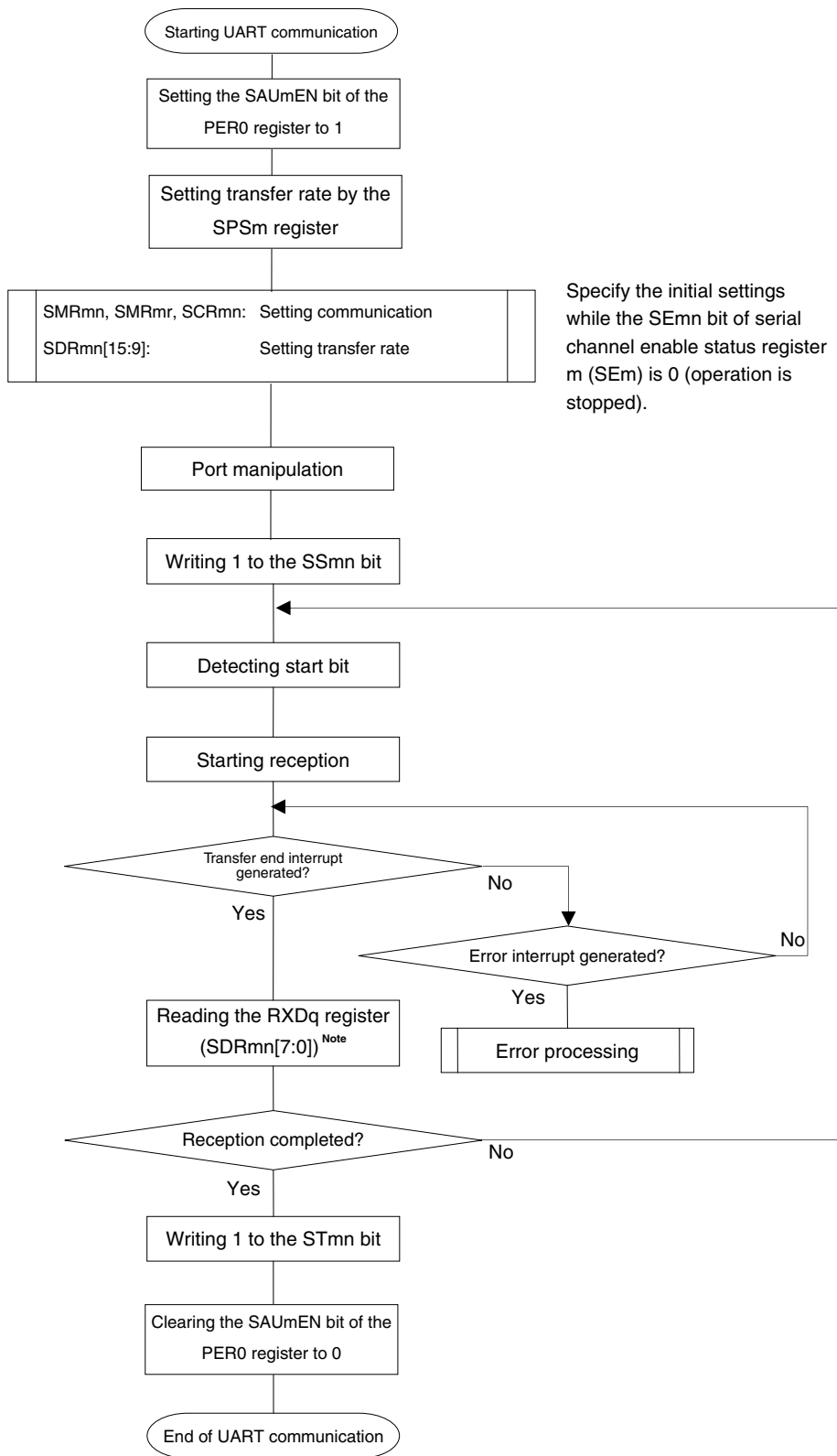
(3) Processing flow

Figure 12-89. Timing Chart of UART Reception



**Remark** m: Unit number (m = 0, 1), n: Channel number (n = 1, 3), mn = 01, 03, 11, 13  
 r: Channel number (r = n - 1), q: UART number (q = 0 to 3)

Figure 12-90. Flowchart of UART Reception



**Note** In case of 9-bit of data, be sure to read SDRmn [8:0] and not the RxDq register.

**Caution** Set the RXEmn bit of SCRmn to 1, and then be sure to set SSmn = 1 after 4 or more fCLK clocks have elapsed.

### 12.6.3 SNOOZE mode function

When RxDq pin input is detected while in the STOP mode, the SNOOZE mode makes data reception that does not require the CPU possible. Only following UARTs can be specified for the reception baud rate adjustment function.

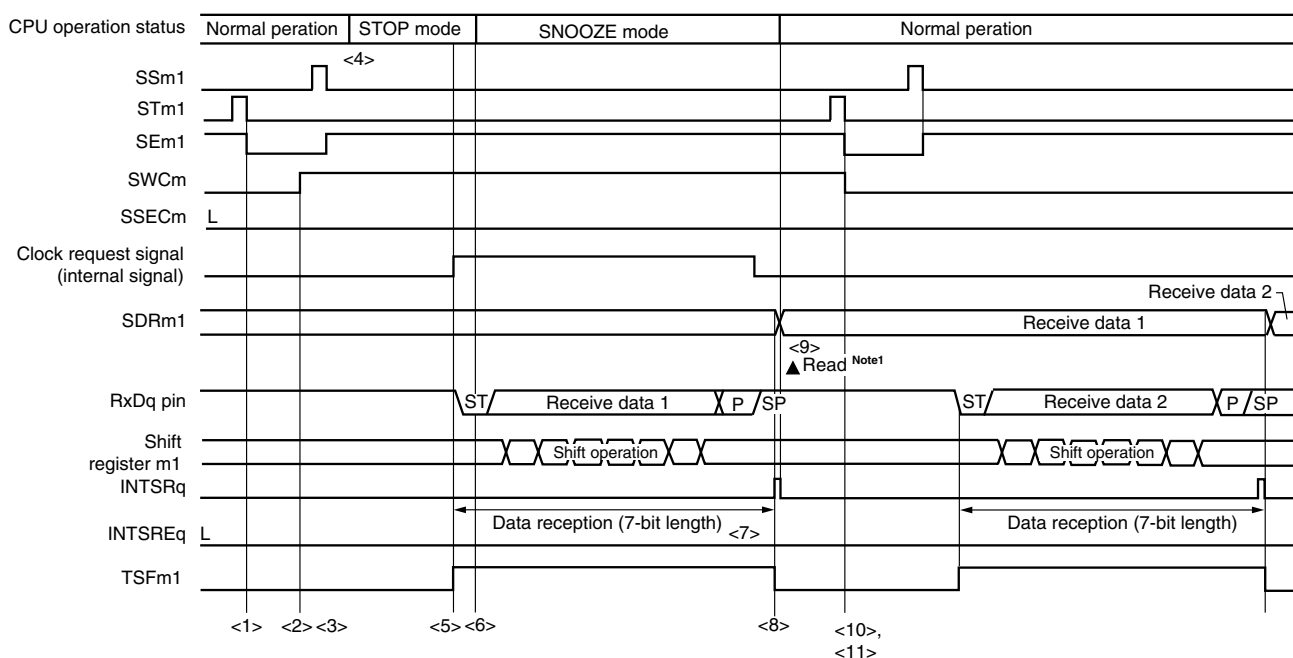
- <R>
- 24 to 64-pin products: UART0
  - 80, 100, 128-pin products: UART0 and UART2

When using the SNOOZE mode function, set the SWCm bit of serial standby control register m (SSCm) to 1 before switching to the STOP mode.

- Cautions 1. The SNOOZE mode can only be specified when the high-speed on-chip oscillator clock is selected for f<sub>CLK</sub>.**
- 2. The maximum transfer rate when using UARTq in the SNOOZE mode is 9600 bps (target).**

#### (1) SNOOZE mode operation (Normal operation)

**Figure 12-91. Timing Chart of SNOOZE Mode Operation (Normal operation mode)**



**Note** Only read received data while SWCm = 1 and before the next edge of the RxDq pin input is detected.

**Caution** Before switching to the SNOOZE mode or after reception operation in the SNOOZE mode finishes, be sure to set the STm1 bit to 1 and clear the SEm1 bit (to stop the operation).

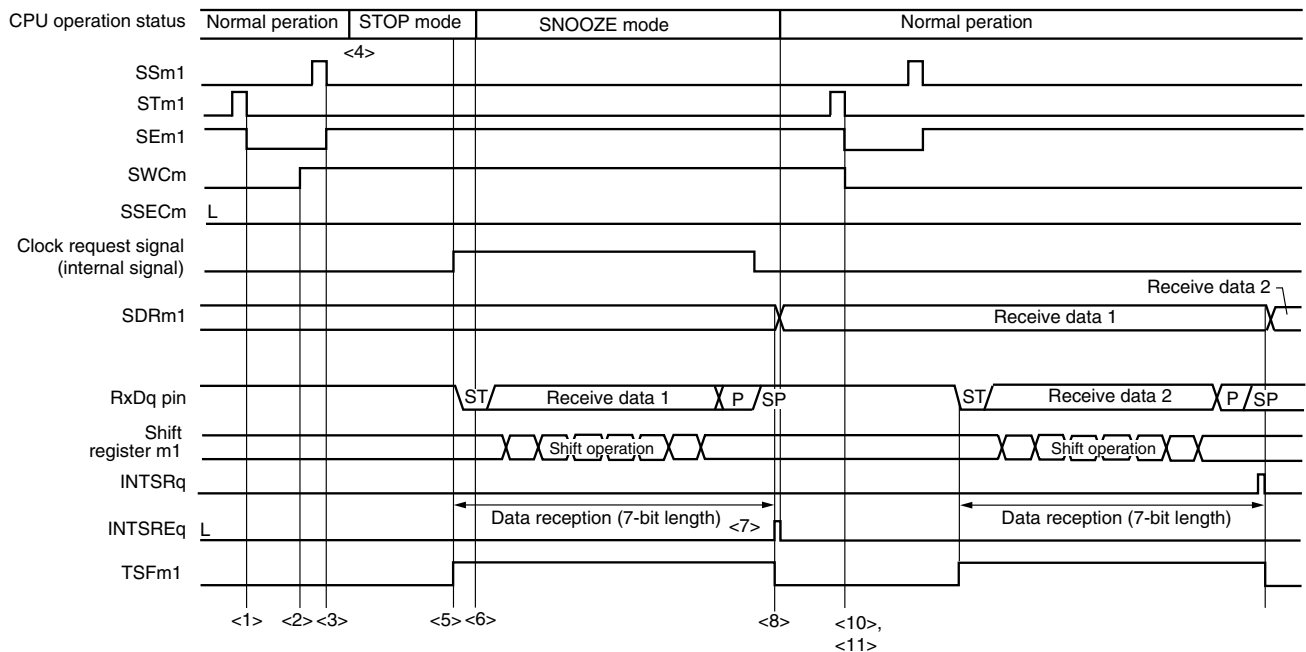
**Remarks 1.** <1> to <11> in the figure correspond to <1> to <11> in **Figure 12-93. Flowchart of SNOOZE Mode Operation (Normal Operation/Abnormal Operation <1>).**

- <R>
2. 24 to 64-pin products: m = 0; q = 0
  - 80, 100, 128-pin products: m = 0, 1; q = 0, 2

**(2) SNOOZE mode operation (Abnormal Operation <1>)**

Abnormal operation <1> is the operation performed when a communication error occurs while SSECm = 0. Because SSECm = 0, an error interrupt (INTSREq) is generated when a communication error occurs.

**Figure 12-92. Timing Chart of SNOOZE Mode Operation (Abnormal Operation <1>)**



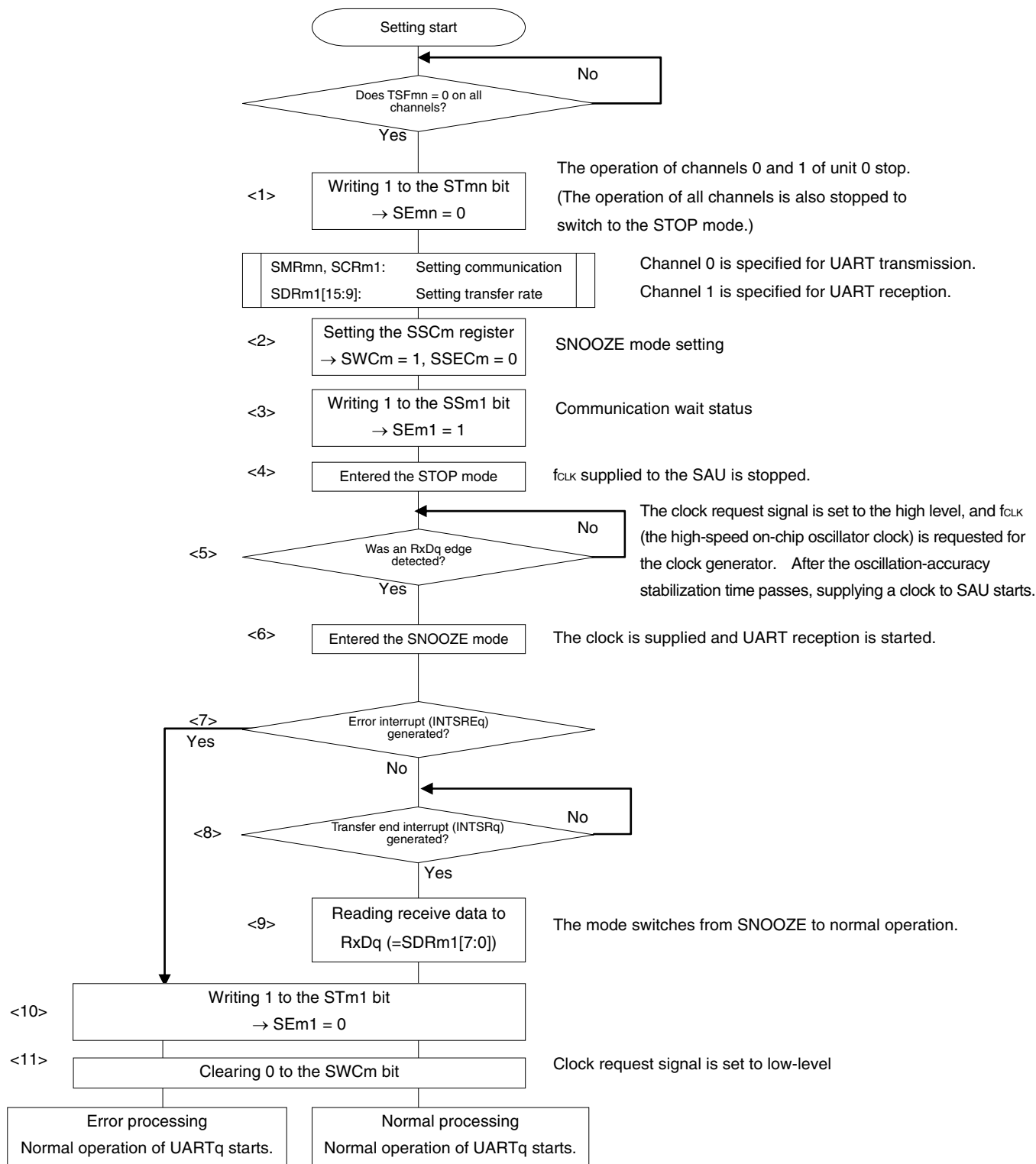
**Caution** Before switching to the SNOOZE mode or after reception operation in the SNOOZE mode finishes, be sure to set the STm1 bit to 1 and clear the SEM1 bit (to stop the operation).

**Remarks 1.** <1> to <11> in the figure correspond to <1> to <11> in Figure 12-93. **Flowchart of SNOOZE Mode Operation (Normal Operation/Abnormal Operation <1>).**

<R>

2. 24 to 64-pin products: m = 0; q = 0
- 80, 100, 128-pin products: m = 0, 1; q = 0, 2

Figure 12-93. Flowchart of SNOOZE Mode Operation (Normal Operation/Abnormal Operation <1>)



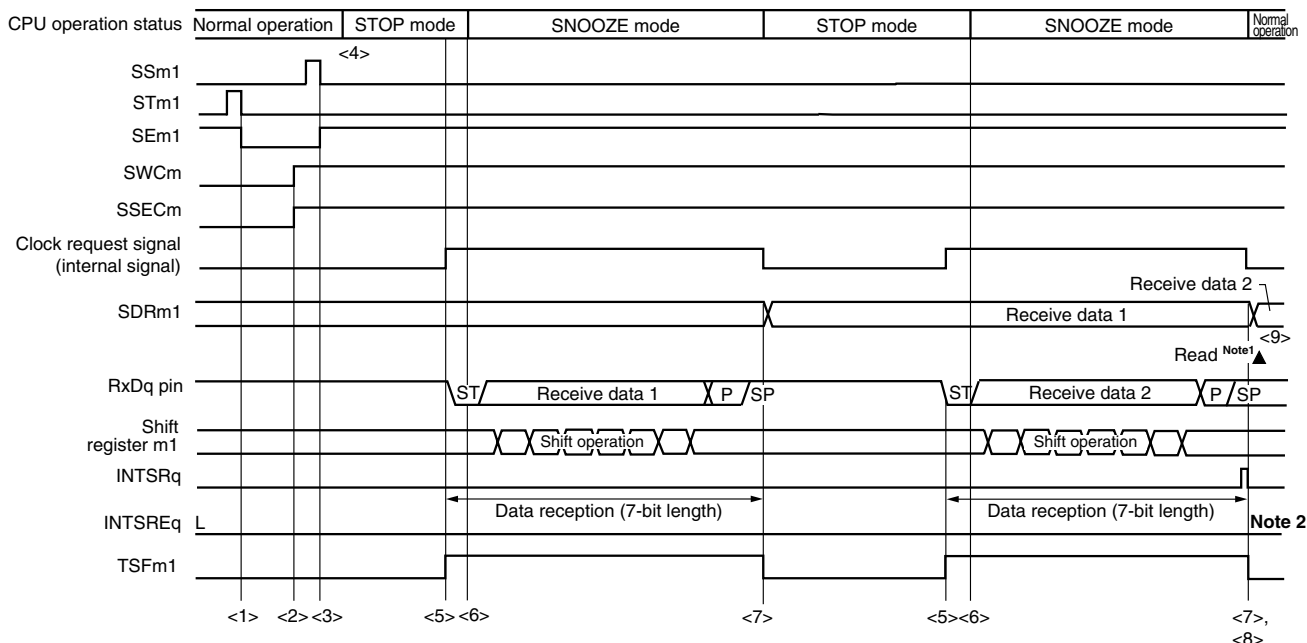
**Remarks 1.** <1> to <11> in the figure correspond to <1> to <11> in **Figure 12-91. Timing Chart of SNOOZE Mode Operation (Normal operation mode)** and **Figure 12-92. Timing Chart of SNOOZE Mode Operation (Abnormal Operation <1>).**

- <R> 2. 24 to 64-pin products: m = 0; q = 0  
 80, 100, 128-pin products: m = 0, 1; q = 0, 2

**(3) SNOOZE mode operation (Abnormal Operation <2>)**

Abnormal operation <2> is the operation performed when a communication error occurs while SSECm = 1. Because SSECm = 1, an error interrupt (INTSREq) is not generated when a communication error occurs.

**Figure 12-94. Timing Chart of SNOOZE Mode Operation (Abnormal Operation <2>)**



- Notes**
1. Only read received data while SWCm = 1 and before the next edge of the RxDq pin input is detected.
  2. After UARTq successfully finishes reception in the SNOOZE mode, it is possible to continue to perform normal reception operations without changing the settings, but, because SSECm = 1, the PEFm1 and FEFm1 bits are not set even if a framing error or parity error occurs. In addition, no error interrupt (INTSREq) is generated.

- Cautions**
1. Before switching to the SNOOZE mode or after reception operation in the SNOOZE mode finishes, be sure to set the STm1 bit to 1 and clear the SEm1 bit (to stop the operation).
  2. When using the SNOOZE mode while SSECm is set to 1, no overrun errors occur. Therefore, when using the SNOOZE mode, read bits 7 to 0 (RxDq) of the SDRm1 register before switching to the STOP mode.

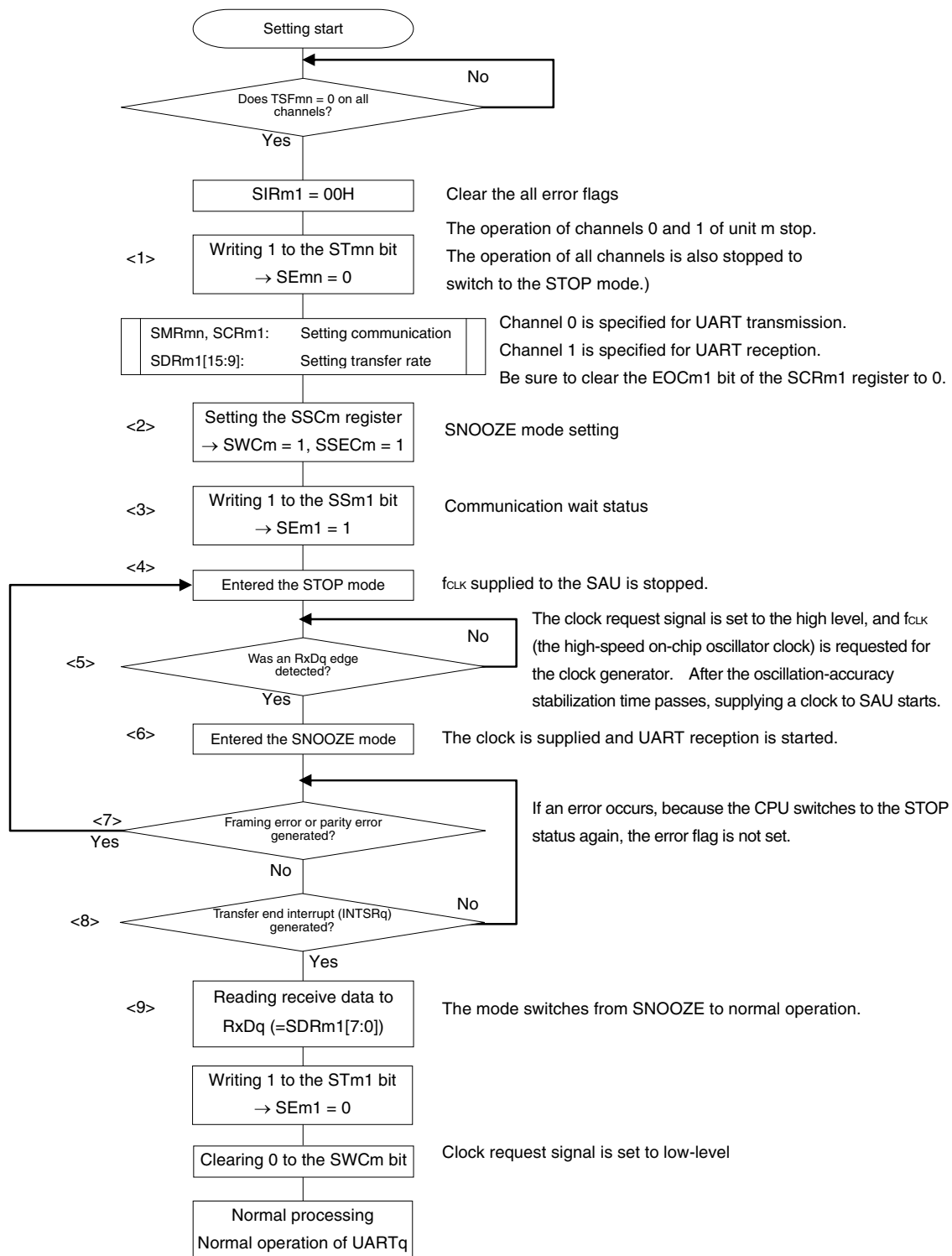
**Remarks** 1. <1> to <9> in the figure correspond to <1> to <9> in **Figure 12-95. Flowchart of SNOOZE Mode Operation (Abnormal Operation <2>)**.

2. 24 to 64-pin products: m = 0; q = 0  
80, 100, 128-pin products: m = 0, 1; q = 0, 2

<R>



Figure 12-95. Flowchart of SNOOZE Mode Operation (Abnormal Operation <2>)



**Caution** When using the SNOOZE mode while SSECm is set to 1, no overrun errors occur. Therefore, when using the SNOOZE mode, read bits 7 to 0 (RxDq) of the SDRm1 register before switching to the STOP mode.

**Remarks 1.** <1> to <9> in the figure correspond to <1> to <9> in Figure 12-94. Timing Chart of SNOOZE Mode Operation (Abnormal Operation <2>).

- <R>
2. 24 to 64-pin products: m = 0; q = 0
  - 80, 100, 128-pin products: m = 0, 1; q = 0, 2

### 12.6.4 Calculating baud rate

#### (1) Baud rate calculation expression

The baud rate for UART (UART0 to UART3) communication can be calculated by the following expressions.

$$\text{(Baud rate)} = \{\text{Operation clock (f}_{\text{MCK}}\text{) frequency of target channel}\} \div (\text{SDRmn}[15:9] + 1) \div 2 \text{ [bps]}$$

**Caution** Setting serial data register mn (SDRmn) SDRmn[15:9] = (0000000B, 0000001B) is prohibited.

**Remarks 1.** When UART is used, the value of SDRmn[15:9] is the value of bits 15 to 9 of the SDRmn register (0000010B to 1111111B) and therefore is 2 to 127.

**2.** m: Unit number (m = 0, 1), n: Channel number (n = 0 to 3), mn = 00 to 03, 10 to 13

The operation clock (f<sub>MCK</sub>) is determined by serial clock select register m (SPSm) and bit 15 (CKSmn) of serial mode register mn (SMRmn).

Table 12-3. Selection of Operation Clock For UART

SMRmn Register	SPSm Register								Operation Clock (f <sub>MCK</sub> ) <sup>Note</sup>	
	CKSmn	PRSm13	PRSm12	PRSm11	PRSm10	PRSm03	PRSm02	PRSm01	PRSm00	f <sub>CLK</sub> = 32 MHz
0	X	X	X	X	0	0	0	0	f <sub>CLK</sub>	32 MHz
	X	X	X	X	0	0	0	1	f <sub>CLK</sub> /2	16 MHz
	X	X	X	X	0	0	1	0	f <sub>CLK</sub> /2 <sup>2</sup>	8 MHz
	X	X	X	X	0	0	1	1	f <sub>CLK</sub> /2 <sup>3</sup>	4 MHz
	X	X	X	X	0	1	0	0	f <sub>CLK</sub> /2 <sup>4</sup>	2 MHz
	X	X	X	X	0	1	0	1	f <sub>CLK</sub> /2 <sup>5</sup>	1 MHz
	X	X	X	X	0	1	1	0	f <sub>CLK</sub> /2 <sup>6</sup>	500 kHz
	X	X	X	X	0	1	1	1	f <sub>CLK</sub> /2 <sup>7</sup>	250 kHz
	X	X	X	X	1	0	0	0	f <sub>CLK</sub> /2 <sup>8</sup>	125 kHz
	X	X	X	X	1	0	0	1	f <sub>CLK</sub> /2 <sup>9</sup>	62.5 kHz
	X	X	X	X	1	0	1	0	f <sub>CLK</sub> /2 <sup>10</sup>	31.25 kHz
	X	X	X	X	1	0	1	1	f <sub>CLK</sub> /2 <sup>11</sup>	15.63 kHz
1	0	0	0	0	X	X	X	X	f <sub>CLK</sub>	32 MHz
	0	0	0	1	X	X	X	X	f <sub>CLK</sub> /2	16 MHz
	0	0	1	0	X	X	X	X	f <sub>CLK</sub> /2 <sup>2</sup>	8 MHz
	0	0	1	1	X	X	X	X	f <sub>CLK</sub> /2 <sup>3</sup>	4 MHz
	0	1	0	0	X	X	X	X	f <sub>CLK</sub> /2 <sup>4</sup>	2 MHz
	0	1	0	1	X	X	X	X	f <sub>CLK</sub> /2 <sup>5</sup>	1 MHz
	0	1	1	0	X	X	X	X	f <sub>CLK</sub> /2 <sup>6</sup>	500 kHz
	0	1	1	1	X	X	X	X	f <sub>CLK</sub> /2 <sup>7</sup>	250 kHz
	1	0	0	0	X	X	X	X	f <sub>CLK</sub> /2 <sup>8</sup>	125 kHz
	1	0	0	1	X	X	X	X	f <sub>CLK</sub> /2 <sup>9</sup>	62.5 kHz
	1	0	1	0	X	X	X	X	f <sub>CLK</sub> /2 <sup>10</sup>	31.25 kHz
	1	0	1	1	X	X	X	X	f <sub>CLK</sub> /2 <sup>11</sup>	15.63 kHz
Other than above									Setting prohibited	

**Note** When changing the clock selected for f<sub>CLK</sub> (by changing the system clock control register (CKC) value), do so after having stopped (serial channel stop register m (STm) = 000FH) the operation of the serial array unit (SAU).

**Remarks 1.** X: Don't care

**2.** m: Unit number (m = 0, 1), n: Channel number (n = 0 to 3), mn = 00 to 03, 10 to 13

**(2) Baud rate error during transmission**

The baud rate error of UART (UART0 to UART3) communication during transmission can be calculated by the following expression. Make sure that the baud rate at the transmission side is within the permissible baud rate range at the reception side.

$$(\text{Baud rate error}) = (\text{Calculated baud rate value}) \div (\text{Target baud rate}) \times 100 - 100 [\%]$$

Here is an example of setting a UART baud rate at  $f_{\text{CLK}} = 32 \text{ MHz}$ .

UART Baud Rate (Target Baud Rate)	$f_{\text{CLK}} = 32 \text{ MHz}$			
	Operation Clock ( $f_{\text{MCK}}$ )	SDRmn[15:9]	Calculated Baud Rate	Error from Target Baud Rate
300 bps	$f_{\text{CLK}}/2^9$	103	300.48 bps	+0.16 %
600 bps	$f_{\text{CLK}}/2^8$	103	600.96 bps	+0.16 %
1200 bps	$f_{\text{CLK}}/2^7$	103	1201.92 bps	+0.16 %
2400 bps	$f_{\text{CLK}}/2^6$	103	2403.85 bps	+0.16 %
4800 bps	$f_{\text{CLK}}/2^5$	103	4807.69 bps	+0.16 %
9600 bps	$f_{\text{CLK}}/2^4$	103	9615.38 bps	+0.16 %
19200 bps	$f_{\text{CLK}}/2^3$	103	19230.8 bps	+0.16 %
31250 bps	$f_{\text{CLK}}/2^3$	63	31250.0 bps	$\pm 0.0 \%$
38400 bps	$f_{\text{CLK}}/2^2$	103	38461.5 bps	+0.16 %
76800 bps	$f_{\text{CLK}}/2$	103	76923.1 bps	+0.16 %
153600 bps	$f_{\text{CLK}}$	103	153846 bps	+0.16 %
312500 bps	$f_{\text{CLK}}$	50	312500 bps	$\pm 0.39 \%$

**Remark** m: Unit number (m = 0, 1), n: Channel number (n = 0, 2), mn = 00, 02, 10, 12

**(3) Permissible baud rate range for reception**

The permissible baud rate range for reception during UART (UART0 to UART3) communication can be calculated by the following expression. Make sure that the baud rate at the transmission side is within the permissible baud rate range at the reception side.

$$\text{(Maximum receivable baud rate)} = \frac{2 \times k \times \text{Nfr}}{2 \times k \times \text{Nfr} - k + 2} \times \text{Brate}$$

$$\text{(Minimum receivable baud rate)} = \frac{2 \times k \times (\text{Nfr} - 1)}{2 \times k \times \text{Nfr} - k - 2} \times \text{Brate}$$

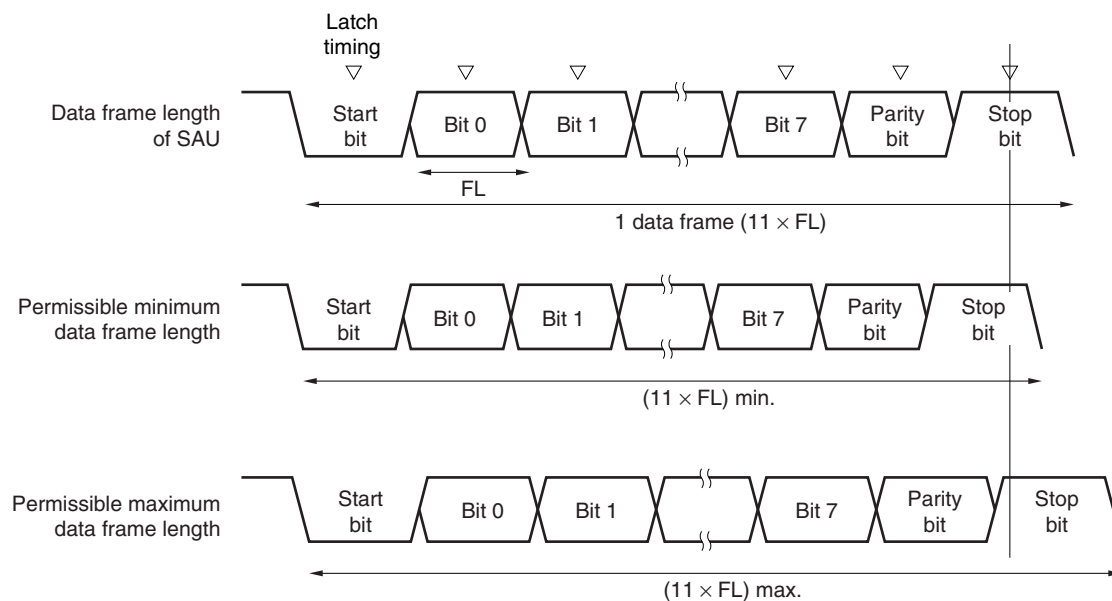
Brate: Calculated baud rate value at the reception side (See 12.6.4 (1) Baud rate calculation expression.)

k: SDRmn[15:9] + 1

Nfr: 1 data frame length [bits]  
 = (Start bit) + (Data length) + (Parity bit) + (Stop bit)

**Remark** m: Unit number (m = 0, 1), n: Channel number (n = 1, 3), mn = 01, 03, 11, 13

**Figure 12-96. Permissible Baud Rate Range for Reception (1 Data Frame Length = 11 Bits)**



As shown in Figure 12-96, the timing of latching receive data is determined by the division ratio set by bits 15 to 9 of serial data register mn (SDRmn) after the start bit is detected. If the last data (stop bit) is received before this latch timing, the data can be correctly received.

**12.6.5 Procedure for processing errors that occurred during UART (UART0 to UART3) communication**

The procedure for processing errors that occurred during UART (UART0 to UART3) communication is described in Figures 12-97 and 12-98.

**Figure 12-97. Processing Procedure in Case of Parity Error or Overrun Error**

Software Manipulation	Hardware Status	Remark
Reads serial data register mn (SDRmn).	→ The BFFmn bit of the SSRmn register is set to 0 and channel n is enabled to receive data.	This is to prevent an overrun error if the next reception is completed during error processing.
Reads serial status register mn (SSRmn).		Error type is identified and the read value is used to clear error flag.
Writes 1 to serial flag clear trigger register mn (SIRmn).	→ Error flag is cleared.	Error can be cleared only during reading, by writing the value read from the SSRmn register to the SIRmn register without modification.

**Figure 12-98. Processing Procedure in Case of Framing Error**

Software Manipulation	Hardware Status	Remark
Reads serial data register mn (SDRmn).	→ The BFFmn bit of the SSRmn register is set to 0 and channel n is enabled to receive data.	This is to prevent an overrun error if the next reception is completed during error processing.
Reads serial status register mn (SSRmn).		Error type is identified and the read value is used to clear error flag.
Writes serial flag clear trigger register mn (SIRmn).	→ Error flag is cleared.	Error can be cleared only during reading, by writing the value read from the SSRmn register to the SIRmn register without modification.
Sets the STmn bit of serial channel stop register m (STm) to 1.	→ The SEMn bit of serial channel enable status register m (SEm) is set to 0 and channel n stops operating.	
Synchronization with other party of communication		Synchronization with the other party of communication is re-established and communication is resumed because it is considered that a framing error has occurred because the start bit has been shifted.
Sets the SSmn bit of serial channel start register m (SSm) to 1.	→ The SEMn bit of serial channel enable status register m (SEm) is set to 1 and channel n is enabled to operate.	

**Remark** m: Unit number (m = 0, 1), n: Channel number (n = 0 to 3), mn = 00 to 03, 10 to 13

## 12.7 LIN Communication Operation

### 12.7.1 LIN transmission

Of UART transmission, UART2 of the 30, 32, 36, 40, 44, 48, 52, 64, 80, 100, and 128-pin products support LIN communication.

For LIN transmission, channel 0 of unit 1 is used.

UART	UART0	UART1	UART2	UART3
Support of LIN communication	Not supported	Not supported	Supported	Not supported
Target channel	–	–	Channel 0 of SAU1	–
Pins used	–	–	TxD2	–
Interrupt	–	–	INTST2	–
	Transfer end interrupt (in single-transfer mode) or buffer empty interrupt (in continuous transfer mode) can be selected.			
Error detection flag	None			
Transfer data length	8 bits			
Transfer rate	Max. $f_{MCK}/6$ [bps] (SDR10 [15:9] = 3 or more), Min. $f_{CLK}/(2 \times 2^{15} \times 128)$ [bps] <sup>Note</sup>			
Data phase	Forward output (default: high level) Reverse output (default: low level)			
Parity bit	The following selectable <ul style="list-style-type: none"> <li>• No parity bit</li> <li>• Appending 0 parity</li> <li>• Appending even parity</li> <li>• Appending odd parity</li> </ul>			
Stop bit	The following selectable <ul style="list-style-type: none"> <li>• Appending 1 bit</li> <li>• Appending 2 bits</li> </ul>			
Data direction	MSB or LSB first			

**Note** Use this operation within a range that satisfies the conditions above and the AC characteristics in the electrical specifications (see **CHAPTER 29 ELECTRICAL SPECIFICATIONS**).

**Remark**  $f_{MCK}$ : Operation clock frequency of target channel  
 $f_{CLK}$ : System clock frequency

LIN stands for Local Interconnect Network and is a low-speed (1 to 20 kbps) serial communication protocol designed to reduce the cost of an automobile network.

Communication of LIN is single-master communication and up to 15 slaves can be connected to one master.

The slaves are used to control switches, actuators, and sensors, which are connected to the master via LIN.

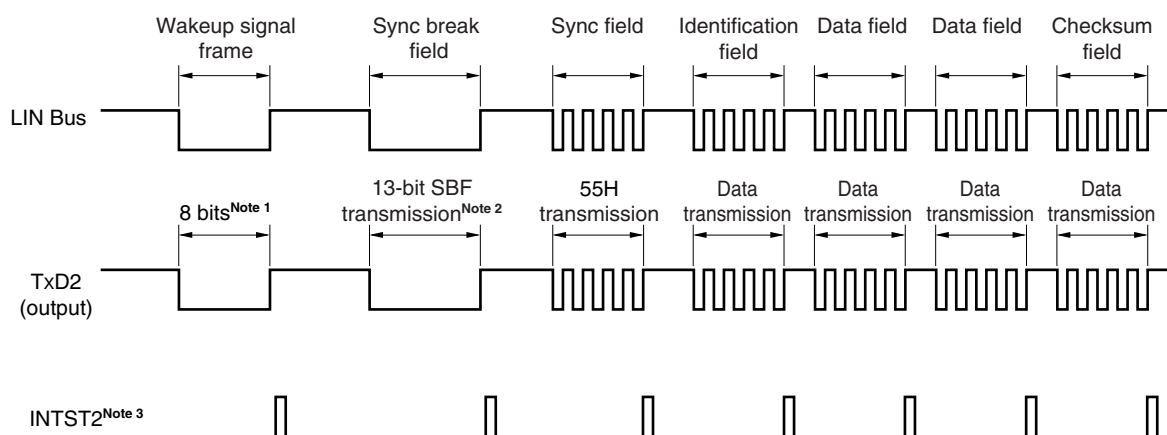
Usually, the master is connected to a network such as CAN (Controller Area Network).

A LIN bus is a single-wire bus to which nodes are connected via transceiver conforming to ISO9141.

According to the protocol of LIN, the master transmits a frame by attaching baud rate information to it. A slave receives this frame and corrects a baud rate error from the master. If the baud rate error of a slave is within ±15%, communication can be established.

Figure 12-99 outlines a transmission operation of LIN.

Figure 12-99. Transmission Operation of LIN



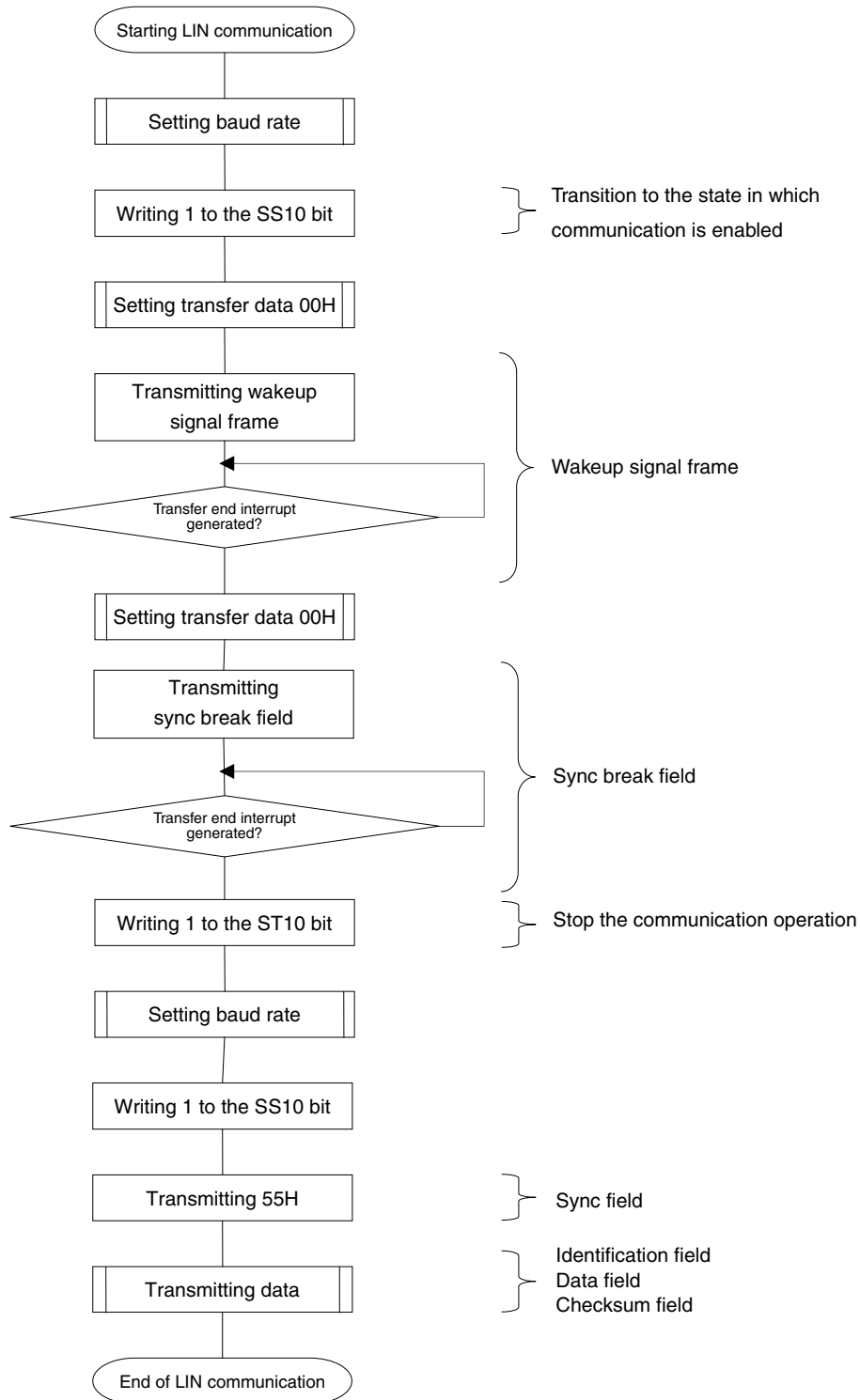
- Notes 1.** The baud rate is set so as to satisfy the standard of the wakeup signal and data of 00H is transmitted.
- 2.** A sync break field is defined to have a width of 13 bits and output a low level. Where the baud rate for main transfer is N [bps], therefore, the baud rate of the sync break field is calculated as follows.  

$$\text{(Baud rate of sync break field)} = 9/13 \times N$$
 By transmitting data of 00H at this baud rate, a sync break field is generated.
- 3.** INTST2 is output upon completion of transmission. INTST2 is also output when SBF transmission is executed.

**Remark** The interval between fields is controlled by software.



Figure 12-100. Flowchart for LIN Transmission



### 12.7.2 LIN reception

Of UART reception, UART2 of the 30, 32, 36, 40, 44, 48, 52, 64, 80, 100, and 128-pin products support LIN communication.

For LIN reception, channel 1 of unit 1 is used.

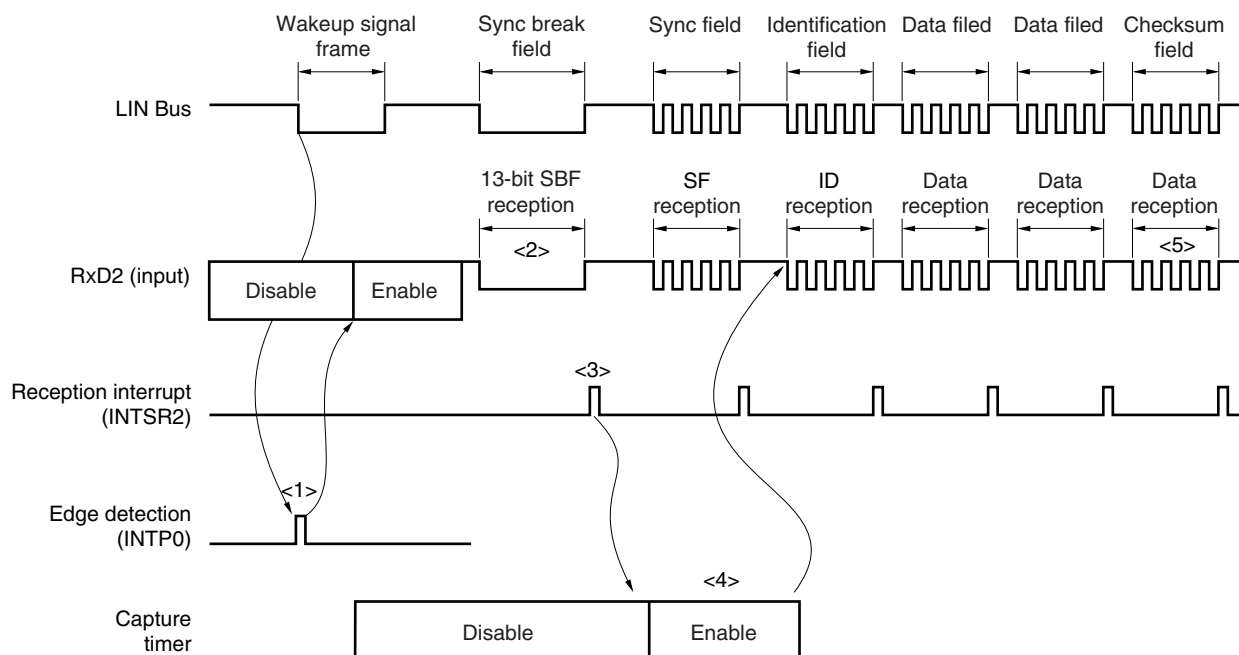
UART	UART0	UART1	UART2	UART3
Support of LIN communication	Not supported	Not supported	Supported	Not supported
Target channel	–	–	Channel 1 of SAU1	–
Pins used	–	–	RxD2	–
Interrupt	–	–	INTSR2	–
	Transfer end interrupt only (Setting the buffer empty interrupt is prohibited.)			
Error interrupt	–	–	INTSRE2	–
Error detection flag	<ul style="list-style-type: none"> <li>• Framing error detection flag (FEF11)</li> <li>• Parity error detection flag (PEF11)</li> <li>• Overrun error detection flag (OVF11)</li> </ul>			
Transfer data length	8 bits			
Transfer rate	Max. $f_{MCK}/6$ [bps] (SDR11 [15:9] = 3 or more), Min. $f_{CLK}/(2 \times 2^{15} \times 128)$ [bps] <sup>Note</sup>			
Data phase	Forward output (default: high level) Reverse output (default: low level)			
Parity bit	The following selectable <ul style="list-style-type: none"> <li>• No parity bit (The parity bit is not checked.)</li> <li>• Appending 0 parity (The parity bit is not checked.)</li> <li>• Even-parity check</li> <li>• Odd-parity check</li> </ul>			
Stop bit	The following selectable <ul style="list-style-type: none"> <li>• Appending 1 bit</li> <li>• Appending 2 bits</li> </ul>			
Data direction	MSB or LSB first			

**Note** Use this operation within a range that satisfies the conditions above and the AC characteristics in the electrical specifications (see **CHAPTER 29 ELECTRICAL SPECIFICATIONS**).

**Remark**  $f_{MCK}$ : Operation clock frequency of target channel  
 $f_{CLK}$ : System clock frequency

Figure 12-101 outlines a reception operation of LIN.

Figure 12-101. Reception Operation of LIN



Here is the flow of signal processing.

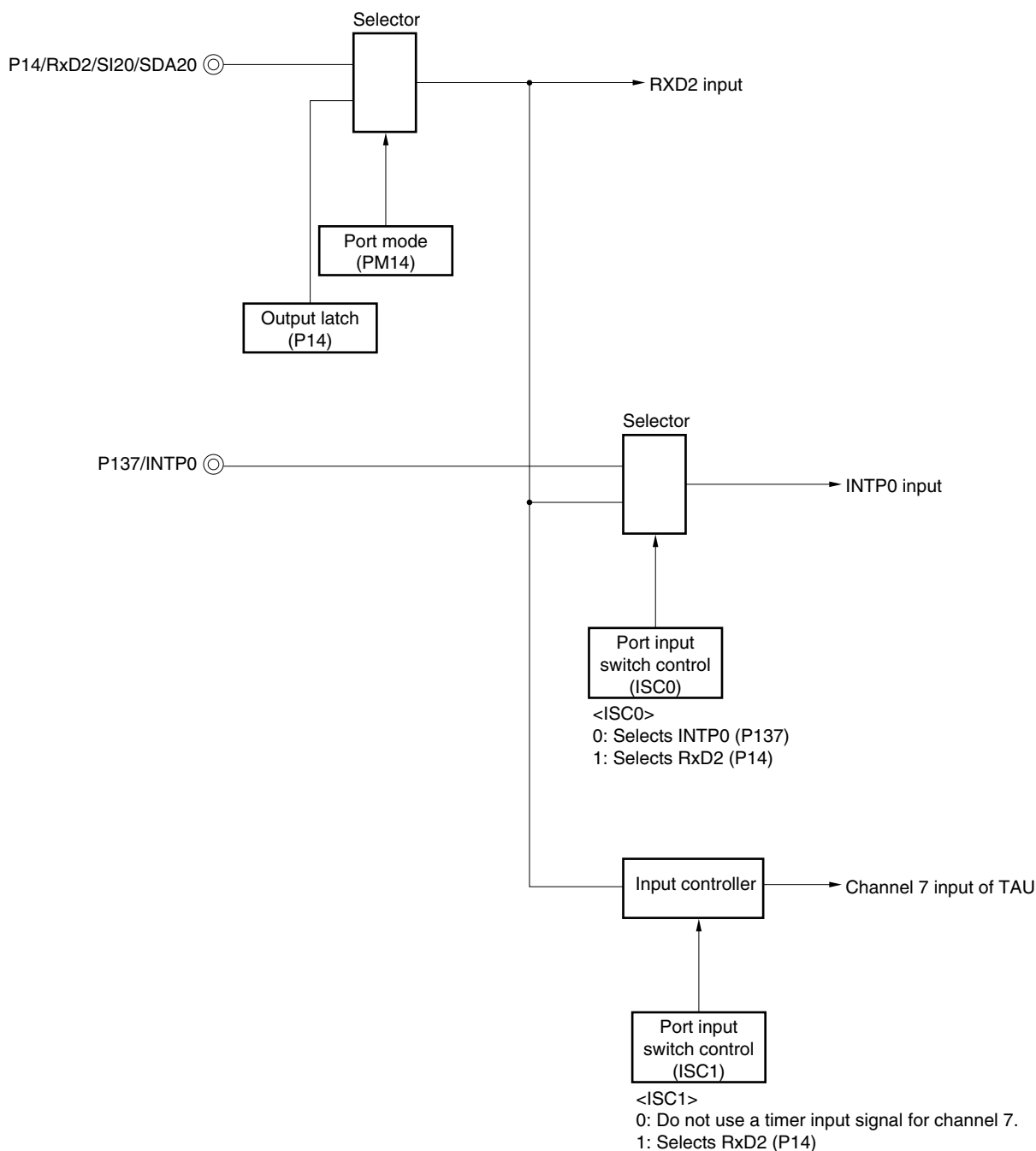
- <1> The wakeup signal is detected by detecting an interrupt edge (INTP0) on a pin. When the wakeup signal is detected, enable reception of UART2 (RXE11 = 1) and wait for SBF reception.
- <2> When the start bit of SBF is detected, reception is started and serial data is sequentially stored in the RxD2 register (= bits 7 to 0 of serial data register 11 (SDR11)) at the set baud rate. When the stop bit is detected, the reception end interrupt request (INTSR2) is generated. When data of low levels of 11 bits or more is detected as SBF, it is judged that SBF reception has been correctly completed. If data of low levels of less than 11 bits is detected as SBF, it is judged that an SBF reception error has occurred, and the system returns to the SBF reception wait status.
- <3> When SBF reception has been correctly completed, start channel 7 of the timer array unit and measure the bit interval (pulse width) of the sync field (see **6.7.5 Operation as input signal high-/low-level width measurement**).
- <4> Calculate a baud rate error from the bit interval of sync field (SF). Stop UART2 once and adjust (re-set) the baud rate.
- <5> The checksum field should be distinguished by software. In addition, processing to initialize UART2 after the checksum field is received and to wait for reception of SBF should also be performed by software.

Figure 12-102 and figure 12-103 show the configuration of a port that manipulates reception of LIN.

The wakeup signal transmitted from the master of LIN is received by detecting an edge of an external interrupt (INTP0). The length of the sync field transmitted from the master can be measured by using the external event capture operation of the timer array unit 0 to calculate a baud-rate error.

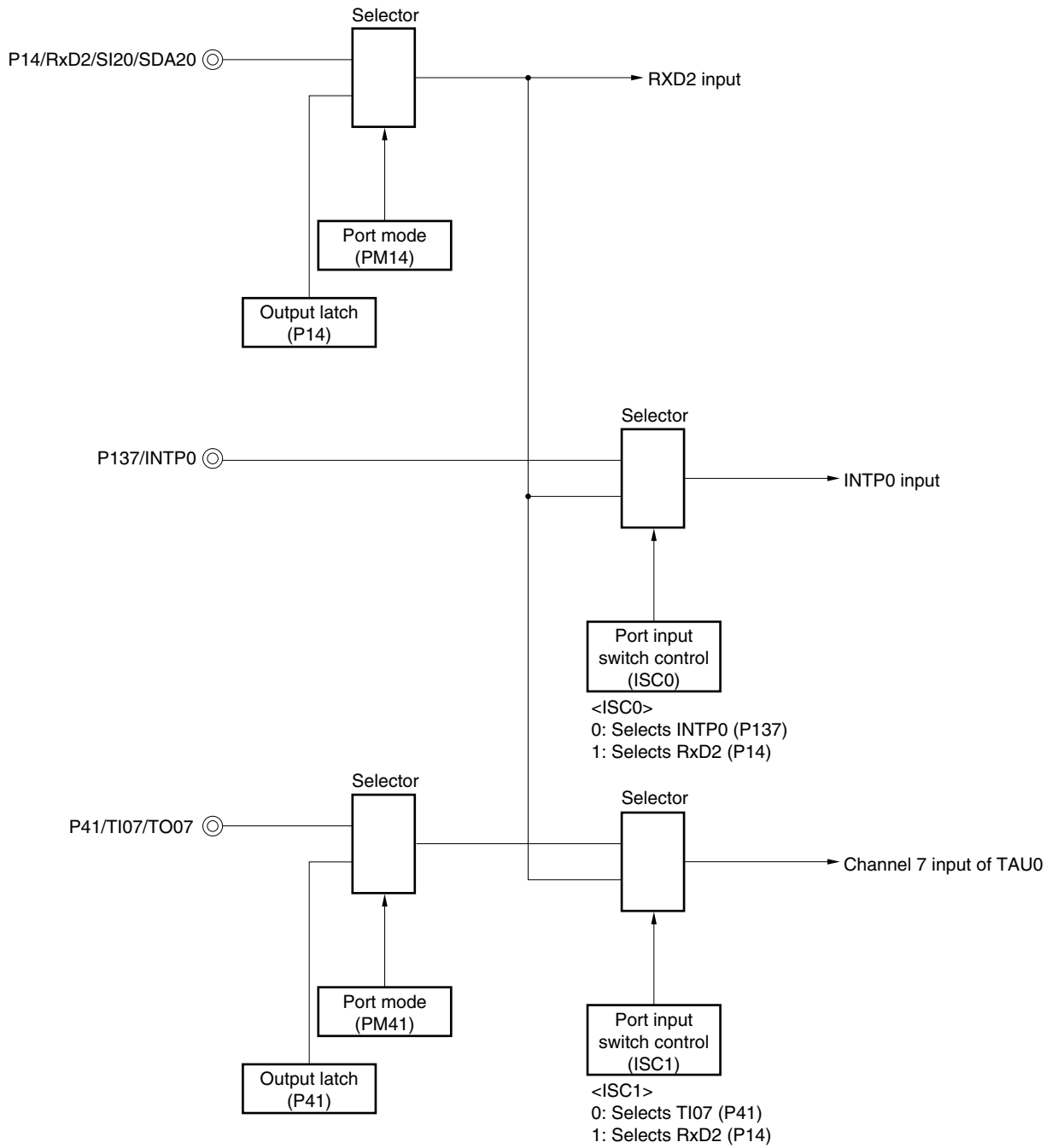
By controlling switch of port input (ISC0/ISC1), the input source of port input (RxD2) for reception can be input to the external interrupt pin (INTP0) and timer array unit

**Figure 12-102 Port Configuration for Manipulating Reception of LIN (30, 32, 36, 40-pin)**



**Remark** ISC0, ISC1: Bits 0 and 1 of the input switch control register (ISC) (See Figure 12-19.)

Figure 12-103 Port Configuration for Manipulating Reception of LIN (44, 48, 52, 64-pin)



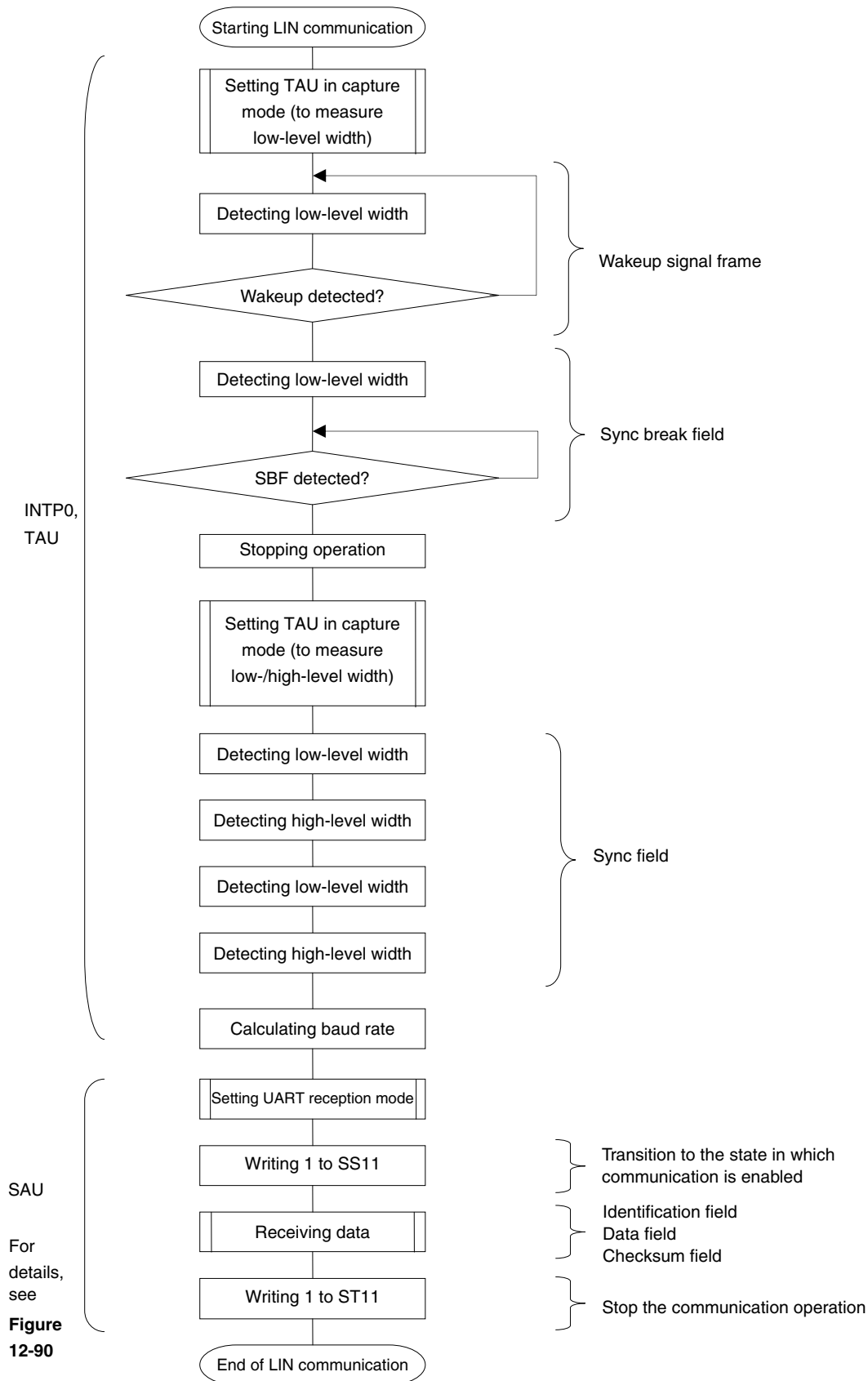
**Remark** ISC0, ISC1: Bits 0 and 1 of the input switch control register (ISC) (See Figure 12-19.)

The peripheral functions used for the LIN communication operation are as follows.

<Peripheral functions used>

- External interrupt (INTP0); Wakeup signal detection  
Usage: To detect an edge of the wakeup signal and the start of communication
- Channel 7 of timer array unit; Baud rate error detection  
Usage: To detect the length of the sync field (SF) and divide it by the number of bits in order to detect an error (The interval of the edge input to RxD2 is measured in the capture mode.)
- Channels 0 and 1 (UART2) of serial array unit 1 (SAU1)

Figure 12-104. Flowchart of LIN Reception



## 12.8 Operation of Simplified I<sup>2</sup>C (IIC00, IIC01, IIC10, IIC11, IIC20, IIC21, IIC30, IIC31) Communication

This is a clocked communication function to communicate with two or more devices by using two lines: serial clock (SCL) and serial data (SDA). This communication function is designed to execute single communication with devices such as EEPROM, flash memory, and A/D converter, and therefore, can be used only by the master.

Make sure by using software, as well as operating the control registers, that the AC specifications of the start and stop conditions are observed.

[Data transmission/reception]

- Master transmission, master reception (only master function with a single master)
- ACK output function<sup>Note</sup> and ACK detection function
- Data length of 8 bits  
(When an address is transmitted, the address is specified by the higher 7 bits, and the least significant bit is used for R/W control.)
- Manual generation of start condition and stop condition

[Interrupt function]

- Transfer end interrupt

[Error detection flag]

- Overrun error
- Parity error (ACK error)

\* [Functions not supported by simplified I<sup>2</sup>C]

- Slave transmission, slave reception
- Arbitration loss detection function
- Wait detection function

**Note** When receiving the last data, ACK will not be output if 0 is written to the SOEmn (SOEm register) bit and serial communication data output is stopped. See the processing flow in **12.8.3 (2)** for details.

**Remark** m: Unit number (m = 0, 1), n: Channel number (n = 0 to 3), mn = 00 to 03, 10 to 13



The channel supporting simplified I<sup>2</sup>C (IIC00, IIC01, IIC10, IIC11, IIC20, IIC21, IIC30, IIC31) is channels 0 to 3 of SAU0 and channel 0 and 1 of SAU1.

- 20, 24, 25-pin products

Unit	Channel	Used as CSI	Used as UART	Used as Simplified I <sup>2</sup> C
0	0	CSI00	UART0	IIC00
	1	–		–
	2	–	UART1	–
	3	CSI11		IIC11
1	0	–	–	–
	1	–	–	–

- 30, 32-pin products

Unit	Channel	Used as CSI	Used as UART	Used as Simplified I <sup>2</sup> C
0	0	CSI00	UART0	IIC00
	1	–		–
	2	–	UART1	–
	3	CSI11		IIC11
1	0	CSI20	UART2 (supporting LIN-bus)	IIC20
	1	–		–

- 36, 40, 44-pin products

Unit	Channel	Used as CSI	Used as UART	Used as Simplified I <sup>2</sup> C
0	0	CSI00	UART0	IIC00
	1	–		–
	2	–	UART1	–
	3	CSI11		IIC11
1	0	CSI20	UART2 (supporting LIN-bus)	IIC20
	1	CSI21		IIC21

- 48, 52-pin products

Unit	Channel	Used as CSI	Used as UART	Used as Simplified I <sup>2</sup> C
0	0	CSI00	UART0	IIC00
	1	CSI01		IIC01
	2	–	UART1	–
	3	CSI11		IIC11
1	0	CSI20	UART2 (supporting LIN-bus)	IIC20
	1	CSI21		IIC21

- 64-pin products

Unit	Channel	Used as CSI	Used as UART	Used as Simplified I <sup>2</sup> C
0	0	CSI00	UART0	IIC00
	1	CSI01		IIC01
	2	CSI10	UART1	IIC10
	3	CSI11		IIC11
1	0	CSI20	UART2 (supporting LIN-bus)	IIC20
	1	CSI21		IIC21

- 80, 100, 128-pin products

Unit	Channel	Used as CSI	Used as UART	Used as Simplified I <sup>2</sup> C
0	0	CSI00	UART0	IIC00
	1	CSI01		IIC01
	2	CSI10	UART1	IIC10
	3	CSI11		IIC11
1	0	CSI20	UART2 (supporting LIN-bus)	IIC20
	1	CSI21		IIC21
	2	CSI30	UART3	IIC30
	3	CSI31		IIC31

Simplified I<sup>2</sup>C (IIC00, IIC01, IIC10, IIC11, IIC20, IIC21, IIC30, IIC31) performs the following four types of communication operations.

- Address field transmission (See **12.8.1.**)
- Data transmission (See **12.8.2.**)
- Data reception (See **12.8.3.**)
- Stop condition generation (See **12.8.4.**)

### 12.8.1 Address field transmission

Address field transmission is a transmission operation that first executes in I<sup>2</sup>C communication to identify the target for transfer (slave). After a start condition is generated, an address (7 bits) and a transfer direction (1 bit) are transmitted in one frame.

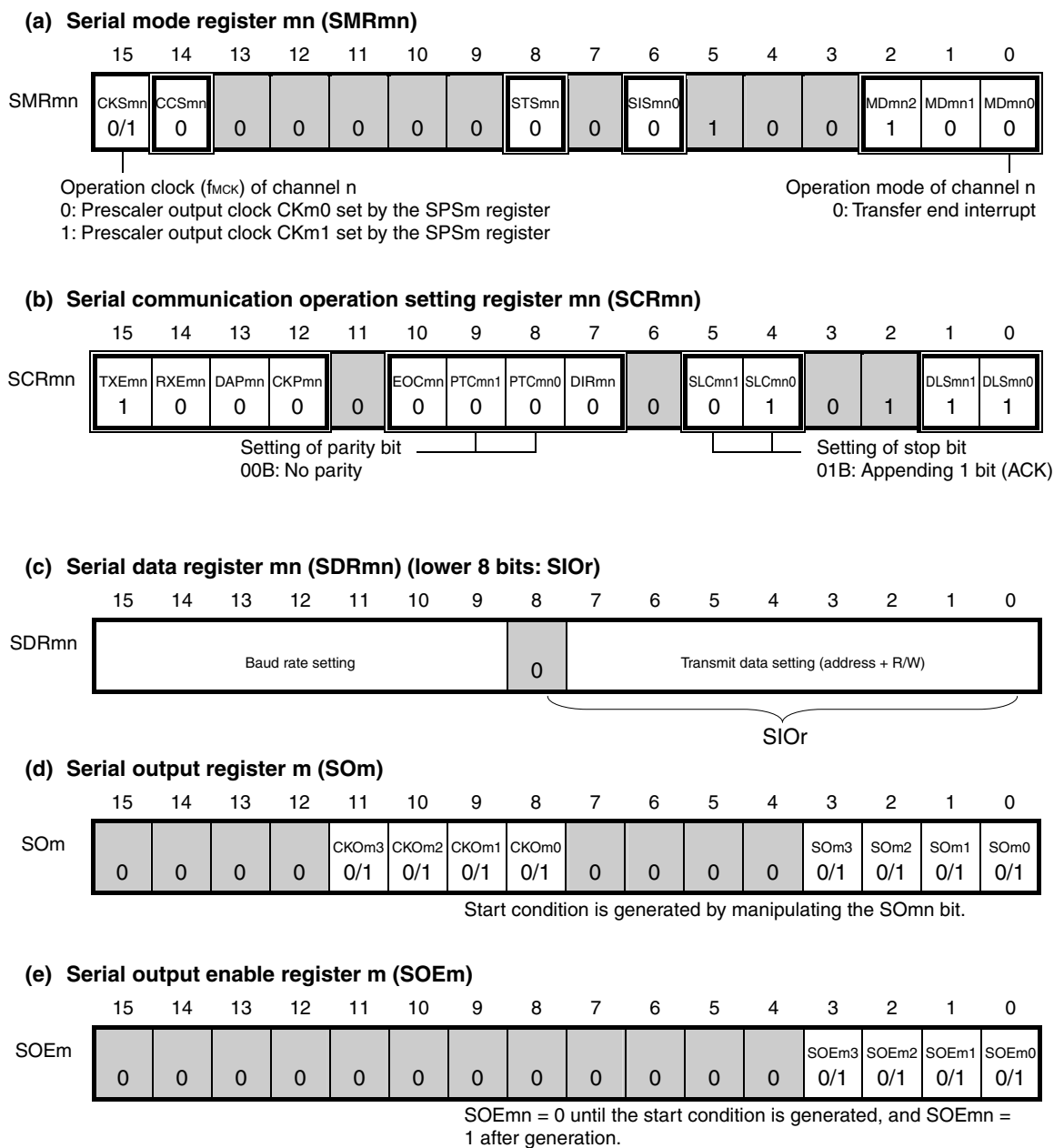
Simplified I <sup>2</sup> C	IIC00	IIC01	IIC10	IIC11	IIC20	IIC21	IIC30	IIC31
Target channel	Channel 0 of SAU0	Channel 1 of SAU0	Channel 2 of SAU0	Channel 3 of SAU0	Channel 0 of SAU1	Channel 1 of SAU1	Channel 2 of SAU1	Channel 3 of SAU1
Pins used	SCL00, SDA00 <sup>Note</sup>	SCL01, SDA01 <sup>Note</sup>	SCL10, SDA10 <sup>Note</sup>	SCL11, SDA11 <sup>Note</sup>	SCL20, SDA20 <sup>Note</sup>	SCL21, SDA21 <sup>Note</sup>	SCL30, SDA30 <sup>Note</sup>	SCL31, SDA31 <sup>Note</sup>
Interrupt	INTIIC00	INTIIC01	INTIIC10	INTIIC11	INTIIC20	INTIIC21	INTIIC30	INTIIC31
	Transfer end interrupt only (Setting the buffer empty interrupt is prohibited.)							
Error detection flag	Parity error detection flag (PEFmn)							
Transfer data length	8 bits (transmitted with specifying the higher 7 bits as address and the least significant bit as R/W control)							
Transfer rate	Max. $f_{mck}/2$ [Hz] (SDRmn[15:9] = 1 or more) $f_{mck}$ : Operation clock frequency of target channel However, the following condition must be satisfied in each mode of I <sup>2</sup> C. <ul style="list-style-type: none"> <li>• Max. 1 MHz (first mode plus)</li> <li>• Max. 400 kHz (first mode)</li> <li>• Max. 100 kHz (standard mode)</li> </ul>							
Data level	Forward output (default: high level)							
Parity bit	No parity bit							
Stop bit	Appending 1 bit (for ACK reception timing)							
Data direction	MSB first							

**Note** To perform communication via simplified I<sup>2</sup>C, set the N-ch open-drain output (V<sub>DD</sub> tolerance) mode (POM03, POM11, POM14, POM50, POM53, POM71, POM74, POM143 = 1) for the port output mode registers (POM0, POM1, POM4, POM5, POM7 to POM9, POM14) (see **4.3 Registers Controlling Port Function** for details). When IIC00, IIC10, IIC20, IIC30, IIC31 communicating with an external device with a different potential, set the N-ch open-drain output (V<sub>DD</sub> tolerance) mode (POM04, POM10, POM15, POM54, POM142 = 1) also for the clock input/output pins (SCL00, SCL10, SCL20, SCL30, SCL31) (see **4.4.4 Connecting to external device with different potential (2.5 V, 3 V)** for details).

**Remark** m: Unit number (m = 0, 1), n: Channel number (n = 0 to 3), mn = 00 to 03, 10 to 13

(1) Register setting

Figure 12-105. Example of Contents of Registers for Address Field Transmission of Simplified I<sup>2</sup>C (IIC00, IIC01, IIC10, IIC11, IIC20, IIC21, IIC30, IIC31) (1/2)



- Remarks 1.** m: Unit number (m = 0, 1), n: Channel number (n = 0 to 3), r: IIC number (r = 00, 01, 10, 11, 20, 21, 30, 31), mn = 00 to 03, 10 to 13
- 2.** □: Setting is fixed in the IIC mode, ■: Setting disabled (set to the initial value)  
 ×: Bit that cannot be used in this mode (set to the initial value when not used in any mode)  
 0/1: Set to 0 or 1 depending on the usage of the user

**Figure 12-105. Example of Contents of Registers for Address Field Transmission of Simplified I<sup>2</sup>C (IIC00, IIC01, IIC10, IIC11, IIC20, IIC21, IIC30, IIC31) (2/2)**

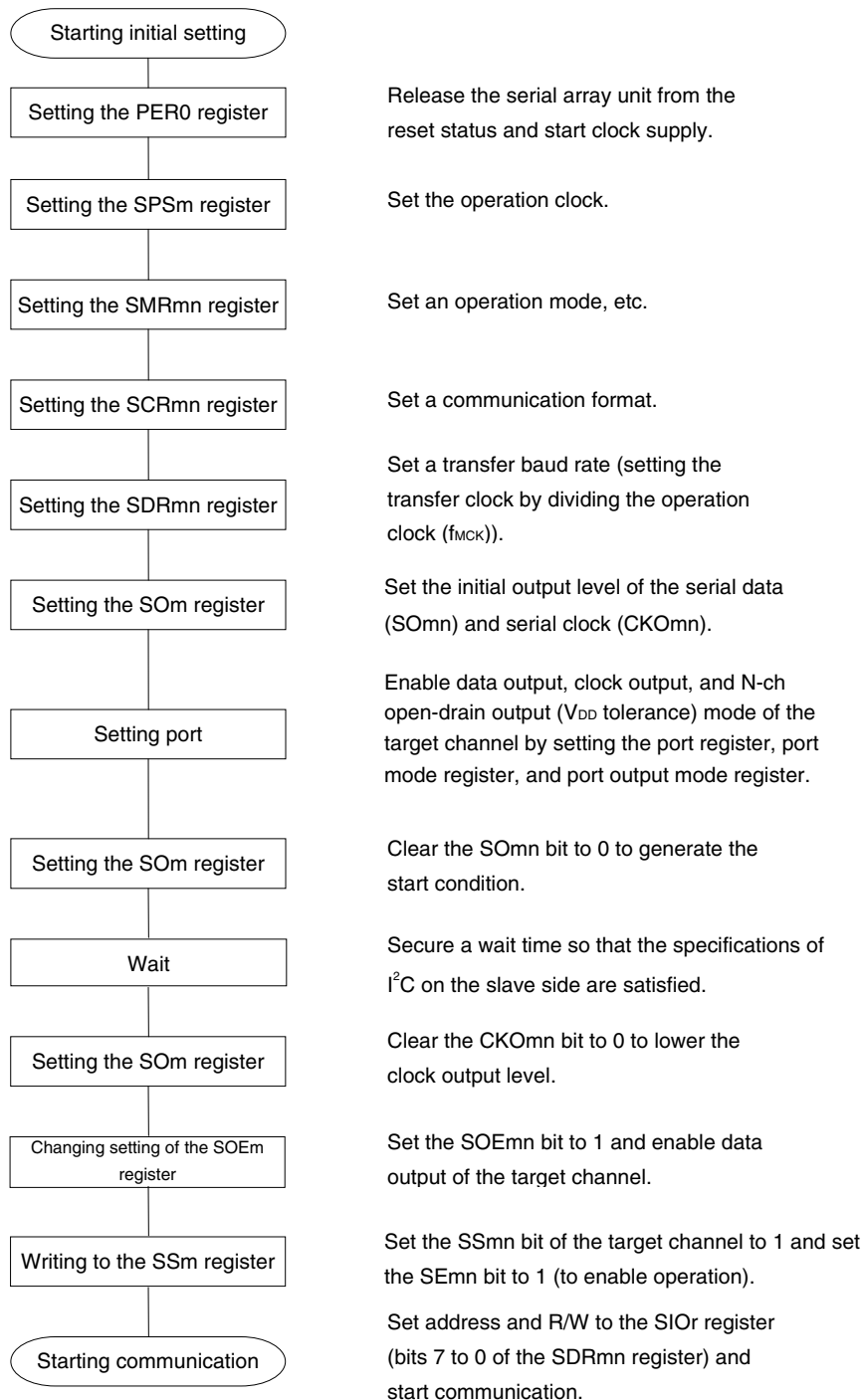
(f) **Serial channel start register m (SSm) ... Sets only the bits of the target channel is 1.**

	15	14	13	12	11	10	9	8	7	6	5	4	3	2	1	0
SSm	0	0	0	0	0	0	0	0	0	0	0	0	SSm3 0/1	SSm2 0/1	SSm1 0/1	SSm0 0/1

- Remarks**
1. m: Unit number (m = 0, 1), n: Channel number (n = 0 to 3), r: IIC number (r = 00, 01, 10, 11, 20, 21, 30, 31), mn = 00 to 03, 10 to 13
  2.  : Setting disabled (set to the initial value)  
 ×: Bit that cannot be used in this mode (set to the initial value when not used in any mode)  
 0/1: Set to 0 or 1 depending on the usage of the user

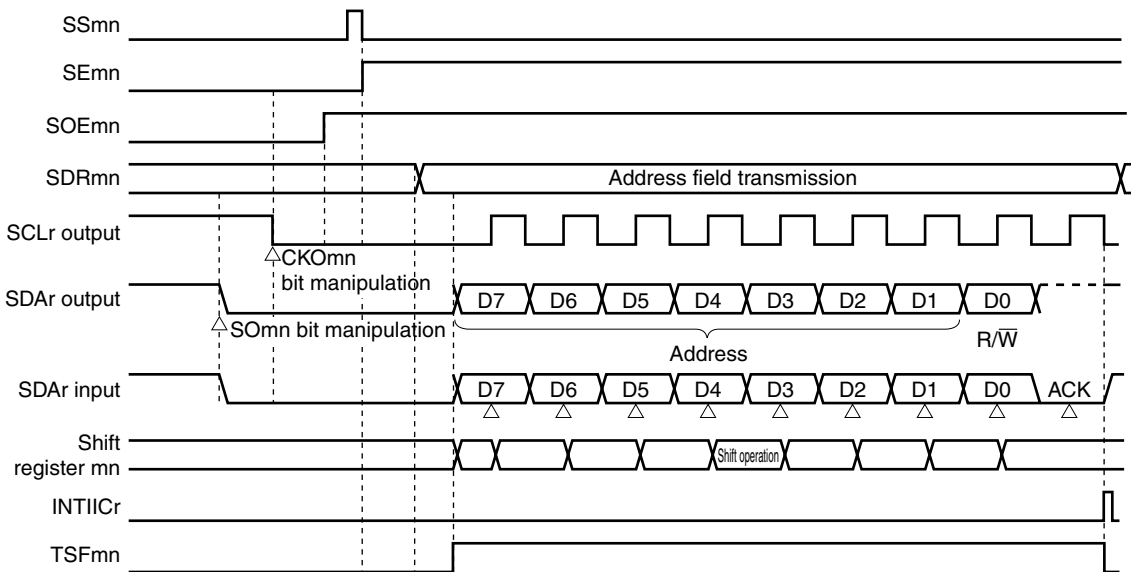
(2) Operation procedure

Figure 12-106. Initial Setting Procedure for Address Field Transmission



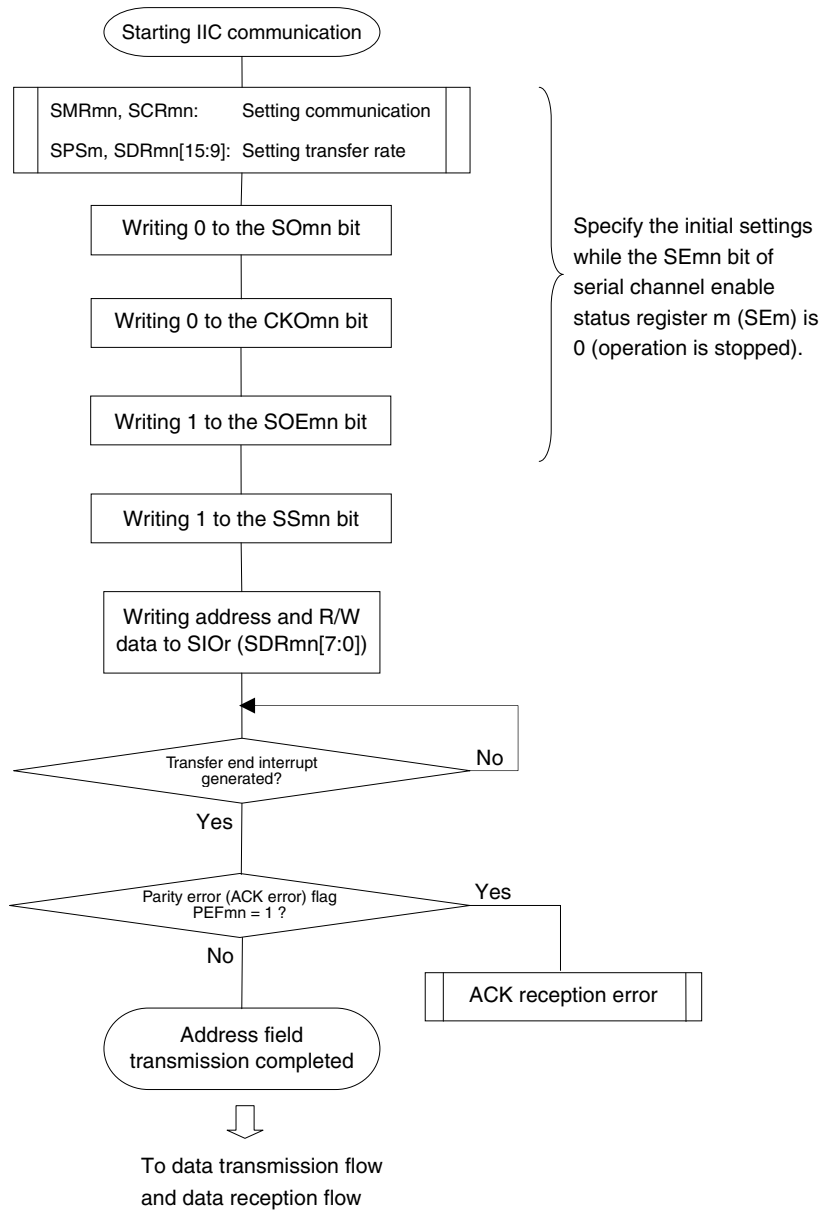
(3) Processing flow

Figure 12-107. Timing Chart of Address Field Transmission



**Remark** m: Unit number (m = 0, 1), n: Channel number (n = 0 to 3), r: IIC number (r = 00, 01, 10, 11, 20, 21, 30, 31), mn = 00 to 03, 10 to 13

**Figure 12-108. Flowchart of Address Field Transmission**





### 12.8.2 Data transmission

Data transmission is an operation to transmit data to the target for transfer (slave) after transmission of an address field. After all data are transmitted to the slave, a stop condition is generated and the bus is released.

Simplified I <sup>2</sup> C	IIC00	IIC01	IIC10	IIC11	IIC20	IIC21	IIC30	IIC31
Target channel	Channel 0 of SAU0	Channel 1 of SAU0	Channel 2 of SAU0	Channel 3 of SAU0	Channel 0 of SAU1	Channel 1 of SAU1	Channel 2 of SAU1	Channel 3 of SAU1
Pins used	SCL00, SDA00 <sup>Note</sup>	SCL01, SDA01 <sup>Note</sup>	SCL10, SDA10 <sup>Note</sup>	SCL11, SDA11 <sup>Note</sup>	SCL20, SDA20 <sup>Note</sup>	SCL21, SDA21 <sup>Note</sup>	SCL30, SDA30 <sup>Note</sup>	SCL31, SDA31 <sup>Note</sup>
Interrupt	INTIIC00	INTIIC01	INTIIC10	INTIIC11	INTIIC20	INTIIC21	INTIIC30	INTIIC31
	Transfer end interrupt only (Setting the buffer empty interrupt is prohibited.)							
Error detection flag	Parity error detection flag (PEFmn)							
Transfer data length	8 bits							
Transfer rate	Max. $f_{MCK}/2$ [Hz] ( $SDR_{mn}[15:9] = 1$ or more) $f_{MCK}$ : Operation clock frequency of target channel However, the following condition must be satisfied in each mode of I <sup>2</sup> C. <ul style="list-style-type: none"> <li>• Max. 1 MHz (first mode plus)</li> <li>• Max. 400 kHz (first mode)</li> <li>• Max. 100 kHz (standard mode)</li> </ul>							
Data level	Forward output (default: high level)							
Parity bit	No parity bit							
Stop bit	Appending 1 bit (for ACK reception timing)							
Data direction	MSB first							

**Note** To perform communication via simplified I<sup>2</sup>C, set the N-ch open-drain output (V<sub>DD</sub> tolerance) mode (POM03, POM11, POM14, POM50, POM53, POM71, POM74, POM143 = 1) for the port output mode registers (POM0, POM1, POM4, POM5, POM7 to POM9, POM14) (see **4.3 Registers Controlling Port Function** for details). When IIC00, IIC10, IIC20, IIC30, IIC31 communicating with an external device with a different potential, set the N-ch open-drain output (V<sub>DD</sub> tolerance) mode (POM04, POM10, POM15, POM54, POM142 = 1) also for the clock input/output pins (SCL00, SCL10, SCL20, SCL30, SCL31) (see **4.4.4 Connecting to external device with different potential (2.5 V, 3 V)** for details).

**Remark** m: Unit number (m = 0, 1), n: Channel number (n = 0 to 3), mn = 00 to 03, 10 to 13

(1) Register setting

Figure 12-109. Example of Contents of Registers for Data Transmission of Simplified I<sup>2</sup>C (IIC00, IIC01, IIC10, IIC11, IIC20, IIC21, IIC30, IIC31) (1/2)

(a) Serial mode register mn (SMRmn) ... Do not manipulate this register during data transmission/reception.

	15	14	13	12	11	10	9	8	7	6	5	4	3	2	1	0
SMRmn	CKSmn	CCSmn						STSmn		SISmn0				MDmn2	MDmn1	MDmn0
	0/1	0	0	0	0	0	0	0	0	0	1	0	0	1	0	0

(b) Serial communication operation setting register mn (SCRmn) ... Do not manipulate the bits of this register, except the TXEmn and RXEmn bits, during data transmission/reception.

	15	14	13	12	11	10	9	8	7	6	5	4	3	2	1	0
SCRmn	TXEmn	RXEmn	DAPmn	CKPmn		EOCmn	PTCmn1	PTCmn0	DIRmn		SLCmn1	SLCmn0			DLSmn1	DLSmn0
	1	0	0	0	0	0	0	0	0	0	0	1	0	0	1	1

(c) Serial data register mn (SDRmn) (lower 8 bits: SIO<sub>r</sub>)

	15	14	13	12	11	10	9	8	7	6	5	4	3	2	1	0
SDRmn	Baud rate setting								0	Transmit data setting						
	SIO <sub>r</sub>															

(d) Serial output register m (SOM) ... Do not manipulate this register during data transmission/reception.

	15	14	13	12	11	10	9	8	7	6	5	4	3	2	1	0
SOM					CKOm3	CKOm2	CKOm1	CKOm0					SOM3	SOM2	SOM1	SOM0
	0	0	0	0	0/1 <sup>Note</sup>	0/1 <sup>Note</sup>	0/1 <sup>Note</sup>	0/1 <sup>Note</sup>	0	0	0	0	0/1 <sup>Note</sup>	0/1 <sup>Note</sup>	0/1 <sup>Note</sup>	0/1 <sup>Note</sup>

(e) Serial output enable register m (SOEm) ... Do not manipulate this register during data transmission/reception.

	15	14	13	12	11	10	9	8	7	6	5	4	3	2	1	0
SOEm													SOEm3	SOEm2	SOEm1	SOEm0
	0	0	0	0	0	0	0	0	0	0	0	0	1	1	1	1

**Note** The value varies depending on the communication data during communication operation.

- Remarks**
- m: Unit number (m = 0, 1), n: Channel number (n = 0 to 3), r: IIC number (r = 00, 01, 10, 11, 20, 21, 30, 31), mn = 00 to 03, 10 to 13
  - : Setting is fixed in the IIC mode, ▒: Setting disabled (set to the initial value)  
 ×: Bit that cannot be used in this mode (set to the initial value when not used in any mode)  
 0/1: Set to 0 or 1 depending on the usage of the user

**Figure 12-109. Example of Contents of Registers for Data Transmission of Simplified I<sup>2</sup>C (IIC00, IIC01, IIC10, IIC11, IIC20, IIC21, IIC30, IIC31) (2/2)**

(f) Serial channel start register m (SSm) ... Do not manipulate this register during data transmission/reception.

	15	14	13	12	11	10	9	8	7	6	5	4	3	2	1	0
SSm	0	0	0	0	0	0	0	0	0	0	0	0	SSm3 0/1	SSm2 0/1	SSm1 0/1	SSm0 0/1

- Remarks**
1. m: Unit number (m = 0, 1), n: Channel number (n = 0 to 3), r: IIC number (r = 00, 01, 10, 11, 20, 21, 30, 31), mn = 00 to 03, 10 to 13
  2.  : Setting disabled (set to the initial value)  
 ×: Bit that cannot be used in this mode (set to the initial value when not used in any mode)  
 0/1: Set to 0 or 1 depending on the usage of the user

(2) Processing flow

Figure 12-110. Timing Chart of Data Transmission

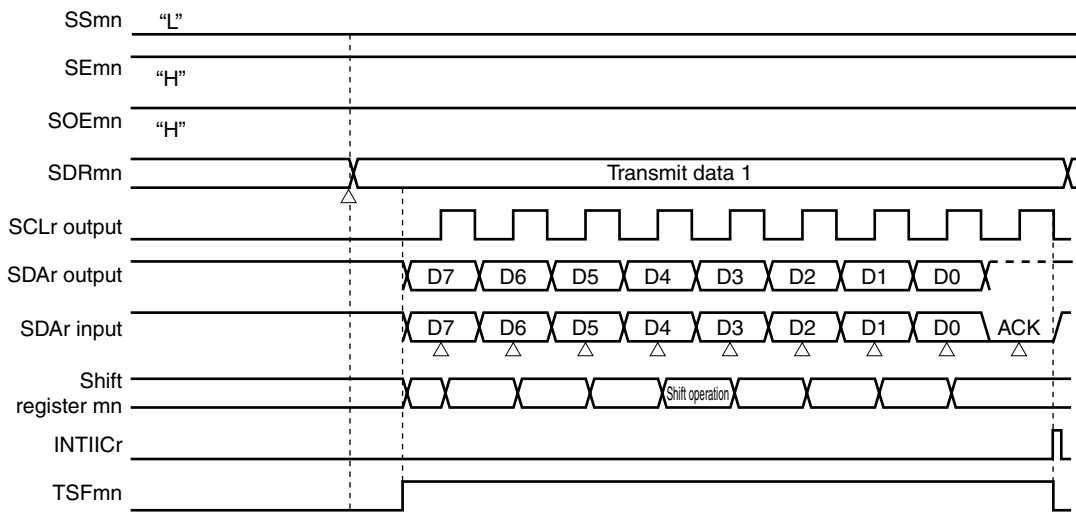


Figure 12-111. Flowchart of Data Transmission



### 12.8.3 Data reception

Data reception is an operation to receive data to the target for transfer (slave) after transmission of an address field. After all data are received to the slave, a stop condition is generated and the bus is released.

Simplified I <sup>2</sup> C	IIC00	IIC01	IIC10	IIC11	IIC20	IIC21	IIC30	IIC31
Target channel	Channel 0 of SAU0	Channel 1 of SAU0	Channel 2 of SAU0	Channel 3 of SAU0	Channel 0 of SAU1	Channel 1 of SAU1	Channel 2 of SAU1	Channel 3 of SAU1
Pins used	SCL00, SDA00 <sup>Note</sup>	SCL01, SDA01 <sup>Note</sup>	SCL10, SDA10 <sup>Note</sup>	SCL11, SDA11 <sup>Note</sup>	SCL20, SDA20 <sup>Note</sup>	SCL21, SDA21 <sup>Note</sup>	SCL30, SDA30 <sup>Note</sup>	SCL31, SDA31 <sup>Note</sup>
Interrupt	INTIIC00	INTIIC01	INTIIC10	INTIIC11	INTIIC20	INTIIC21	INTIIC30	INTIIC31
	Transfer end interrupt only (Setting the buffer empty interrupt is prohibited.)							
Error detection flag	Overrun error detection flag (OVFmn) only							
Transfer data length	8 bits							
Transfer rate	Max. $f_{MCK}/2$ [Hz] ( $SDR_{mn}[15:9] = 1$ or more) $f_{MCK}$ : Operation clock frequency of target channel However, the following condition must be satisfied in each mode of I <sup>2</sup> C. <ul style="list-style-type: none"> <li>• Max. 1 MHz (first mode plus)</li> <li>• Max. 400 kHz (first mode)</li> <li>• Max. 100 kHz (standard mode)</li> </ul>							
Data level	Forward output (default: high level)							
Parity bit	No parity bit							
Stop bit	Appending 1 bit (ACK transmission)							
Data direction	MSB first							

**Note** To perform communication via simplified I<sup>2</sup>C, set the N-ch open-drain output ( $V_{DD}$  tolerance) mode (POM03, POM11, POM14, POM50, POM53, POM71, POM74, POM143 = 1) for the port output mode registers (POM0, POM1, POM4, POM5, POM7 to POM9, POM14) (see **4.3 Registers Controlling Port Function** for details). When IIC00, IIC10, IIC20, IIC30, IIC31 communicating with an external device with a different potential, set the N-ch open-drain output ( $V_{DD}$  tolerance) mode (POM04, POM10, POM15, POM54, POM142 = 1) also for the clock input/output pins (SCL00, SCL10, SCL20, SCL30, SCL31) (see **4.4.4 Connecting to external device with different potential (2.5 V, 3 V)** for details).

**Remark** m: Unit number (m = 0, 1), n: Channel number (n = 0 to 3), mn = 00 to 03, 10 to 13

(1) Register setting

Figure 12-112. Example of Contents of Registers for Data Reception of Simplified I<sup>2</sup>C (IIC00, IIC01, IIC10, IIC11, IIC20, IIC21, IIC30, IIC31) (1/2)

(a) Serial mode register mn (SMRmn) ... Do not manipulate this register during data transmission/reception.

	15	14	13	12	11	10	9	8	7	6	5	4	3	2	1	0
SMRmn	CKSmn	CCSmn						STSmn		SISmn0				MDmn2	MDmn1	MDmn0
	0/1	0	0	0	0	0	0	0	0	0	1	0	0	1	0	0

(b) Serial communication operation setting register mn (SCRmn) ... Do not manipulate the bits of this register, except the TXEmn and RXEmn bits, during data transmission/reception.

	15	14	13	12	11	10	9	8	7	6	5	4	3	2	1	0
SCRmn	TXEmn	RXEmn	DAPmn	CKPmn		EOCmn	PTCmn1	PTCmn0	DIRmn		SLCmn1	SLCmn0			DLSmn1	DLSmn0
	0	1	0	0	0	0	0	0	0	0	0	1	0	1	1	1

(c) Serial data register mn (SDRmn) (lower 8 bits: SIO<sub>r</sub>)

	15	14	13	12	11	10	9	8	7	6	5	4	3	2	1	0
SDRmn	Baud rate setting								0	Dummy transmit data setting (FFH)						
	SIO <sub>r</sub>															

(d) Serial output register m (SO<sub>m</sub>) ... Do not manipulate this register during data transmission/reception.

	15	14	13	12	11	10	9	8	7	6	5	4	3	2	1	0
SO <sub>m</sub>					CKO <sub>m3</sub>	CKO <sub>m2</sub>	CKO <sub>m1</sub>	CKO <sub>m0</sub>					SO <sub>m3</sub>	SO <sub>m2</sub>	SO <sub>m1</sub>	SO <sub>m0</sub>
	0	0	0	0	0/1 <sup>Note</sup>	0/1 <sup>Note</sup>	0/1 <sup>Note</sup>	0/1 <sup>Note</sup>	0	0	0	0	0/1 <sup>Note</sup>	0/1 <sup>Note</sup>	0/1 <sup>Note</sup>	0/1 <sup>Note</sup>

(e) Serial output enable register m (SOE<sub>m</sub>) ... Do not manipulate this register during data transmission/reception.

	15	14	13	12	11	10	9	8	7	6	5	4	3	2	1	0
SOE <sub>m</sub>													SOE <sub>m3</sub>	SOE <sub>m2</sub>	SOE <sub>m1</sub>	SOE <sub>m0</sub>
	0	0	0	0	0	0	0	0	0	0	0	0	0/1	0/1	0/1	0/1

**Note** The value varies depending on the communication data during communication operation.

- Remarks**
- m: Unit number (m = 0, 1), n: Channel number (n = 0 to 3), r: IIC number (r = 00, 01, 10, 11, 20, 21, 30, 31), mn = 00 to 03, 10 to 13
  - : Setting is fixed in the IIC mode, ◻: Setting disabled (set to the initial value)  
 ×: Bit that cannot be used in this mode (set to the initial value when not used in any mode)  
 0/1: Set to 0 or 1 depending on the usage of the user

**Figure 12-112. Example of Contents of Registers for Data Reception of Simplified I<sup>2</sup>C (IIC00, IIC01, IIC10, IIC11, IIC20, IIC21, IIC30, IIC31) (2/2)**

(f) Serial channel start register m (SSm) ... Do not manipulate this register during data transmission/reception.

	15	14	13	12	11	10	9	8	7	6	5	4	3	2	1	0
SSm	0	0	0	0	0	0	0	0	0	0	0	0	SSm3 0/1	SSm2 0/1	SSm1 0/1	SSm0 0/1

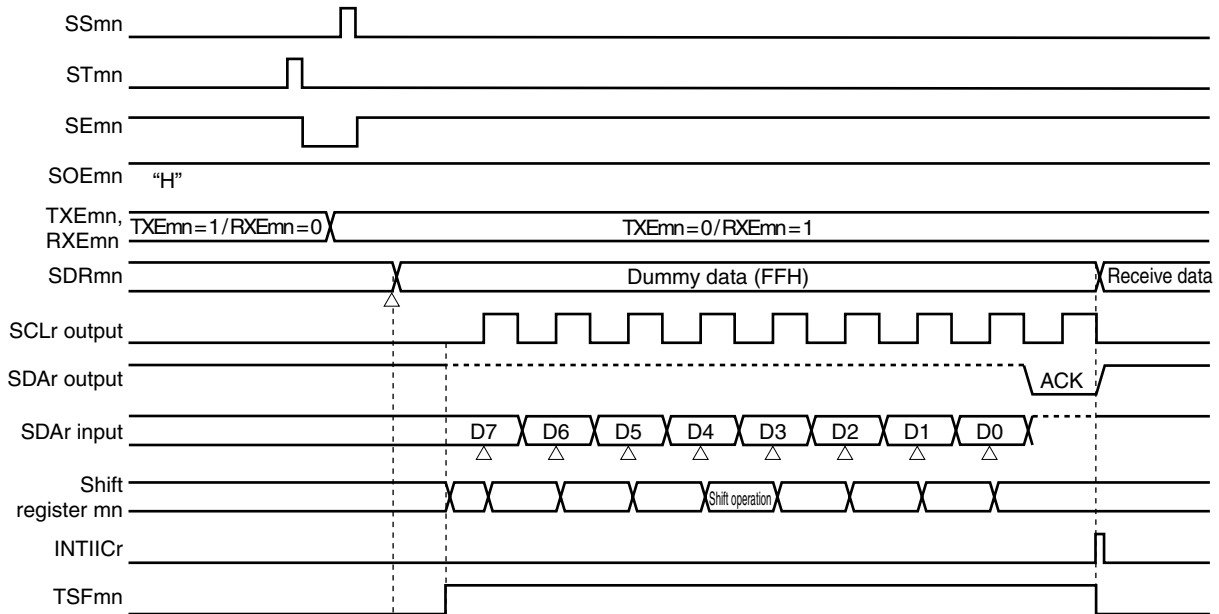
**Remarks 1.** m: Unit number (m = 0, 1), n: Channel number (n = 0 to 3), r: IIC number (r = 00, 01, 10, 11, 20, 21, 30, 31), mn = 00 to 03, 10 to 13

- 2.** : Setting is fixed in the CSI master transmission mode, : Setting disabled (set to the initial value)  
 ×: Bit that cannot be used in this mode (set to the initial value when not used in any mode)  
 0/1: Set to 0 or 1 depending on the usage of the user

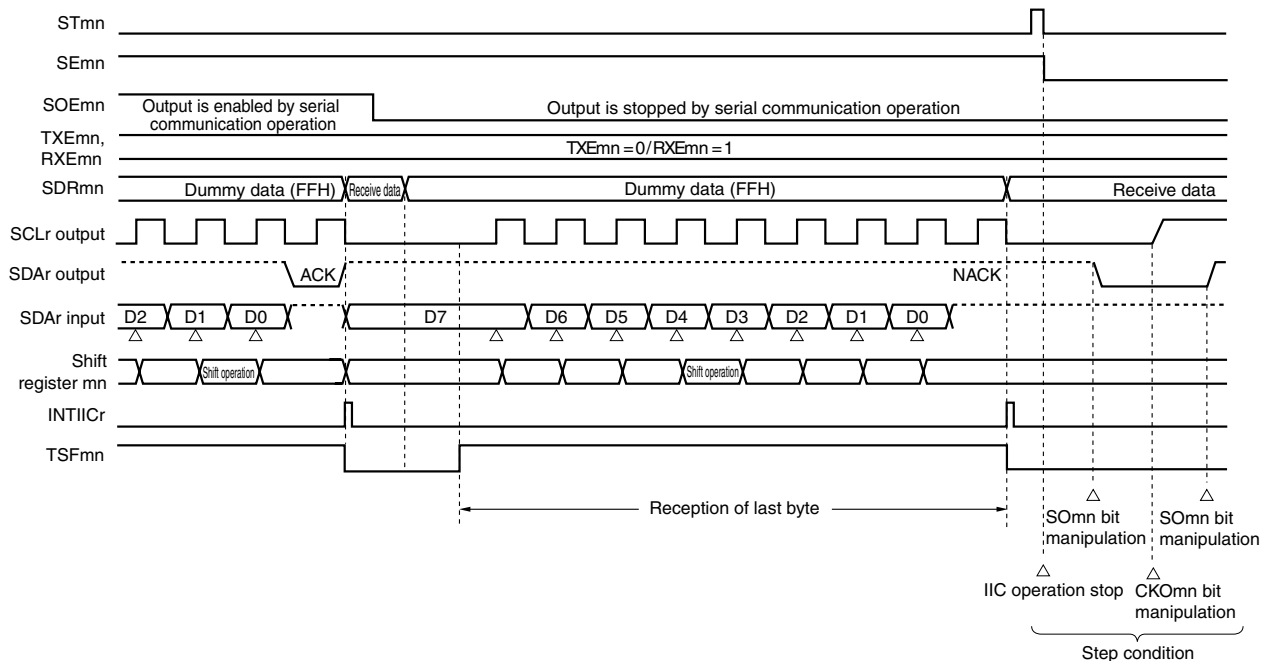
(2) Processing flow

Figure 12-113. Timing Chart of Data Reception

(a) When starting data reception



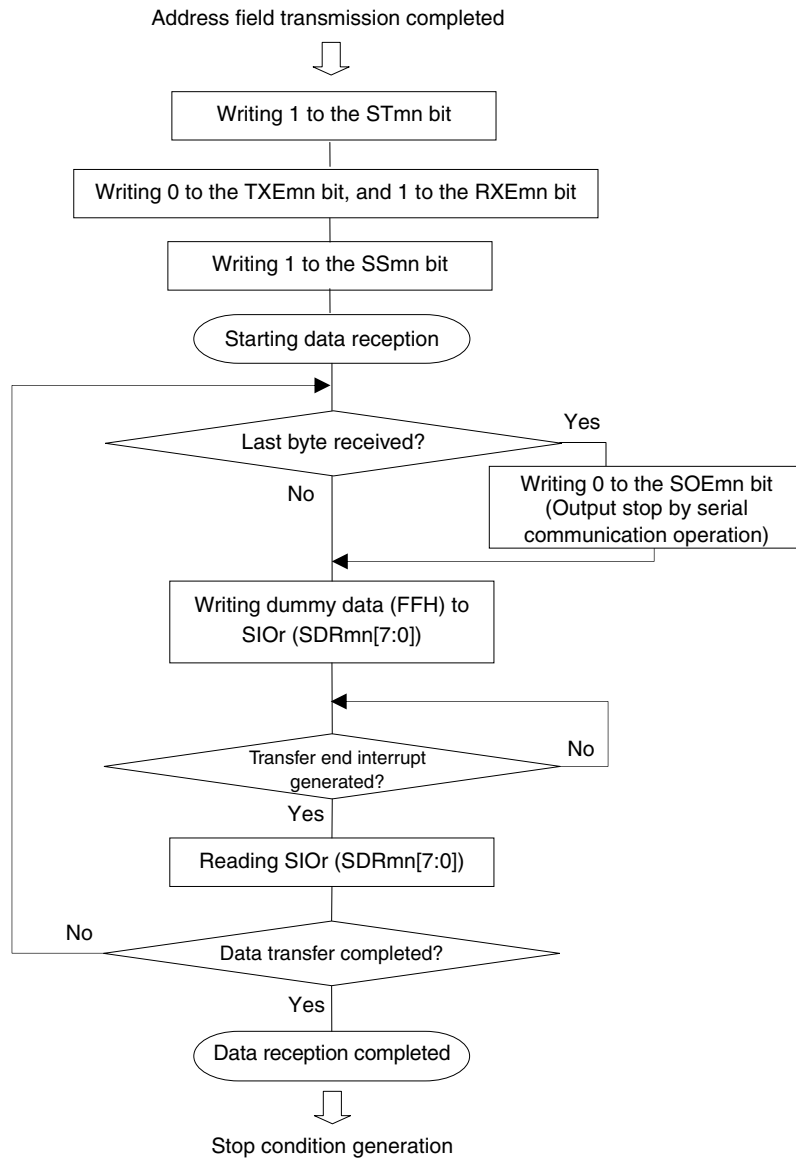
(b) When receiving last data



**Remark** m: Unit number (m = 0, 1), n: Channel number (n = 0 to 3), r: IIC number (r = 00, 01, 10, 11, 20, 21, 30, 31), mn = 00 to 03, 10 to 13



Figure 12-114. Flowchart of Data Reception



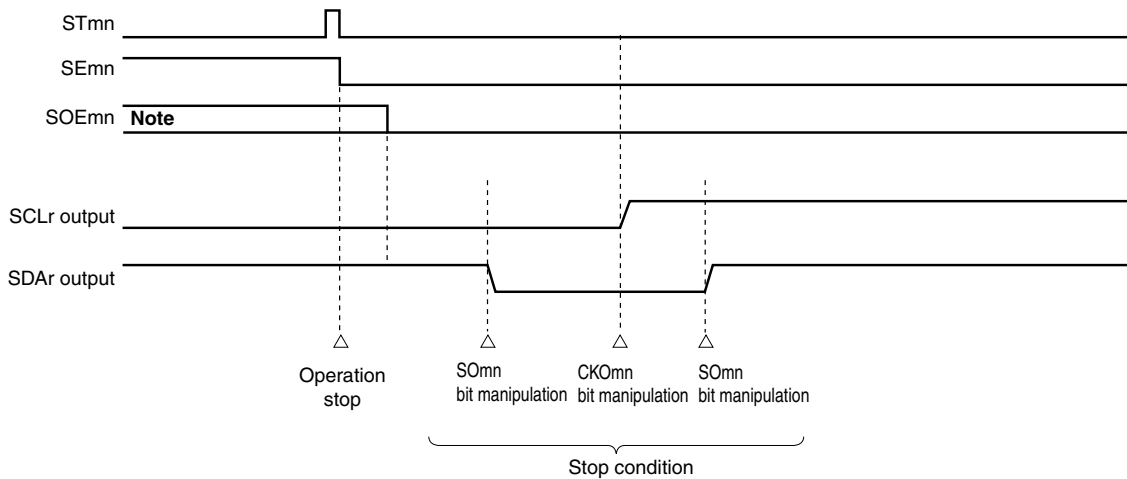
**Caution** ACK is not output when the last data is received (NACK). Communication is then completed by setting “1” to the STmn bit of serial channel stop register m (STm) to stop operation and generating a stop condition.

12.8.4 Stop condition generation

After all data are transmitted to or received from the target slave, a stop condition is generated and the bus is released.

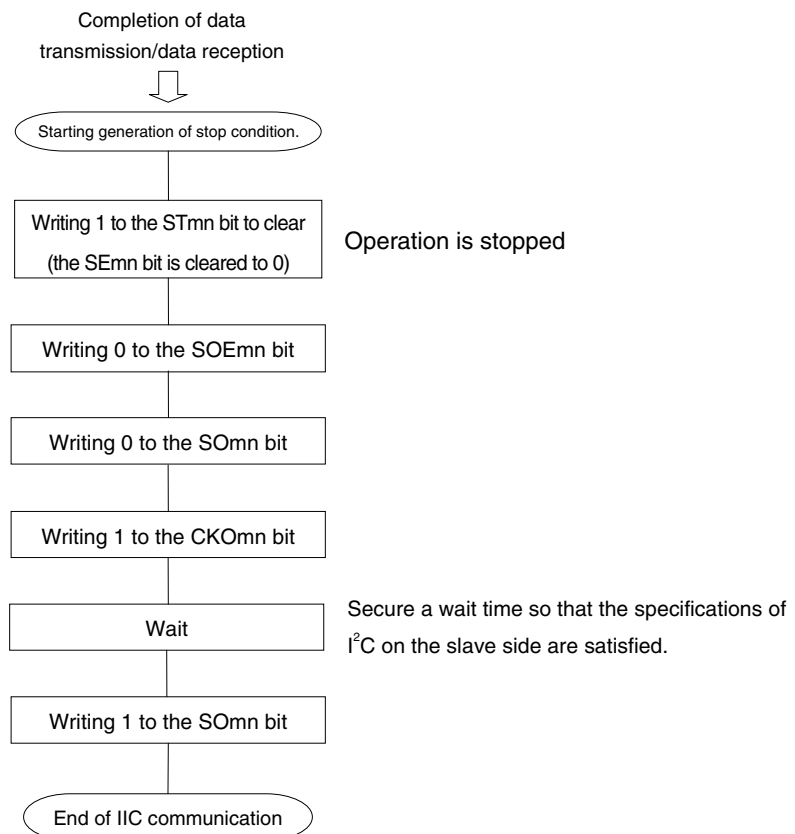
(1) Processing flow

Figure 12-115. Timing Chart of Stop Condition Generation



**Note** During a receive operation, the SOEmn bit of serial output enable register m (SOEm) is cleared to 0 before receiving the last data.

Figure 12-116. Flowchart of Stop Condition Generation



### 12.8.5 Calculating transfer rate

The transfer rate for simplified I<sup>2</sup>C (IIC00, IIC01, IIC10, IIC11, IIC20, IIC21, IIC30, IIC31) communication can be calculated by the following expressions.

$$(\text{Transfer rate}) = \{\text{Operation clock (f}_{\text{MCK}}\text{) frequency of target channel}\} \div (\text{SDRmn}[15:9] + 1) \div 2$$

**Caution** Setting SDRmn[15:9] = 000000B is prohibited. Setting SDRmn[15:9] = 000001B or more.

- Remarks 1.** The value of SDRmn[15:9] is the value of bits 15 to 9 of the SDRmn register (000001B to 111111B) and therefore is 1 to 127.
- 2.** m: Unit number (m = 0, 1), n: Channel number (n = 0 to 3), mn = 00 to 03, 10 to 13

The operation clock (f<sub>MCK</sub>) is determined by serial clock select register m (SPSm) and bit 15 (CKSmn) of serial mode register mn (SMRmn).

**Table 12-4. Selection of Operation Clock For Simplified I<sup>2</sup>C**

SMRmn Register	SPSm Register								Operation Clock (f <sub>MCK</sub> ) <sup>Note</sup>	
	CKSmn	PRSm13	PRSm12	PRSm11	PRSm10	PRSm03	PRSm02	PRSm01	PRSm00	f <sub>CLK</sub> = 32 MHz
0	X	X	X	X	0	0	0	0	f <sub>CLK</sub>	32 MHz
	X	X	X	X	0	0	0	1	f <sub>CLK</sub> /2	16 MHz
	X	X	X	X	0	0	1	0	f <sub>CLK</sub> /2 <sup>2</sup>	8 MHz
	X	X	X	X	0	0	1	1	f <sub>CLK</sub> /2 <sup>3</sup>	4 MHz
	X	X	X	X	0	1	0	0	f <sub>CLK</sub> /2 <sup>4</sup>	2 MHz
	X	X	X	X	0	1	0	1	f <sub>CLK</sub> /2 <sup>5</sup>	1 MHz
	X	X	X	X	0	1	1	0	f <sub>CLK</sub> /2 <sup>6</sup>	500 kHz
	X	X	X	X	0	1	1	1	f <sub>CLK</sub> /2 <sup>7</sup>	250 kHz
	X	X	X	X	1	0	0	0	f <sub>CLK</sub> /2 <sup>8</sup>	125 kHz
	X	X	X	X	1	0	0	1	f <sub>CLK</sub> /2 <sup>9</sup>	62.5 kHz
	X	X	X	X	1	0	1	0	f <sub>CLK</sub> /2 <sup>10</sup>	31.25 kHz
	X	X	X	X	1	0	1	1	f <sub>CLK</sub> /2 <sup>11</sup>	15.63 kHz
1	0	0	0	0	X	X	X	X	f <sub>CLK</sub>	32 MHz
	0	0	0	1	X	X	X	X	f <sub>CLK</sub> /2	16 MHz
	0	0	1	0	X	X	X	X	f <sub>CLK</sub> /2 <sup>2</sup>	8 MHz
	0	0	1	1	X	X	X	X	f <sub>CLK</sub> /2 <sup>3</sup>	4 MHz
	0	1	0	0	X	X	X	X	f <sub>CLK</sub> /2 <sup>4</sup>	2 MHz
	0	1	0	1	X	X	X	X	f <sub>CLK</sub> /2 <sup>5</sup>	1 MHz
	0	1	1	0	X	X	X	X	f <sub>CLK</sub> /2 <sup>6</sup>	500 kHz
	0	1	1	1	X	X	X	X	f <sub>CLK</sub> /2 <sup>7</sup>	250 kHz
	1	0	0	0	X	X	X	X	f <sub>CLK</sub> /2 <sup>8</sup>	125 kHz
	1	0	0	1	X	X	X	X	f <sub>CLK</sub> /2 <sup>9</sup>	62.5 kHz
	1	0	1	0	X	X	X	X	f <sub>CLK</sub> /2 <sup>10</sup>	31.25 kHz
	1	0	1	1	X	X	X	X	f <sub>CLK</sub> /2 <sup>11</sup>	15.63 kHz
Other than above									Setting prohibited	

**Note** When changing the clock selected for f<sub>CLK</sub> (by changing the system clock control register (CKC) value), do so after having stopped (serial channel stop register m (STm) = 000FH) the operation of the serial array unit (SAU).

**Remarks 1.** X: Don't care

**2.** m: Unit number (m = 0, 1), n: Channel number (n = 0 to 3), mn = 00 to 03, 10 to 13

Here is an example of setting an I<sup>2</sup>C transfer rate where f<sub>MCK</sub> = f<sub>CLK</sub> = 32 MHz.

I <sup>2</sup> C Transfer Mode (Desired Transfer Rate)	f <sub>CLK</sub> = 32 MHz			
	Operation Clock (f <sub>MCK</sub> )	SDRmn[15:9]	Calculated Transfer Rate	Error from Desired Transfer Rate
100 kHz	f <sub>CLK</sub> /2	79	100 kHz	0.0%
400 kHz	f <sub>CLK</sub>	39	400 kHz	0.0%
1 MHz	f <sub>CLK</sub> /2	7	1 MHz	0.0%

**12.8.6 Procedure for processing errors that occurred during simplified I<sup>2</sup>C (IIC00, IIC01, IIC10, IIC11, IIC20, IIC21, IIC30, IIC31) communication**

The procedure for processing errors that occurred during simplified I<sup>2</sup>C (IIC00, IIC01, IIC10, IIC11, IIC20, IIC21, IIC30, IIC31) communication is described in Figure 12-117 and 12-118.

**Figure 12-117. Processing Procedure in Case of Overrun Error**

Software Manipulation	Hardware Status	Remark
Reads serial data register mn (SDRmn).	→ The BFFmn bit of the SSRmn register is set to 0 and channel n is enabled to receive data.	This is to prevent an overrun error if the next reception is completed during error processing.
Reads serial status register mn (SSRmn).		Error type is identified and the read value is used to clear error flag.
Writes 1 to serial flag clear trigger register mn (SIRmn).	→ Error flag is cleared.	Error can be cleared only during reading, by writing the value read from the SSRmn register to the SIRmn register without modification.

**Figure 12-118. Processing Procedure in Case of Parity Error (ACK error) in Simplified I<sup>2</sup>C Mode**

Software Manipulation	Hardware Status	Remark
Reads serial data register mn (SDRmn).	→ The BFFmn bit of the SSRmn register is set to 0 and channel n is enabled to receive data.	This is to prevent an overrun error if the next reception is completed during error processing.
Reads serial status register mn (SSRmn).		Error type is identified and the read value is used to clear error flag.
Writes serial flag clear trigger register mn (SIRmn).	→ Error flag is cleared.	Error can be cleared only during reading, by writing the value read from the SSRmn register to the SIRmn register without modification.
Sets the STmn bit of serial channel stop register m (STm) to 1.	→ The SEMn bit of serial channel enable status register m (SEm) is set to 0 and channel n stops operation.	Slave is not ready for reception because ACK is not returned. Therefore, a stop condition is created, the bus is released, and communication is started again from the start condition. Or, a restart condition is generated and transmission can be redone from address transmission.
Creates stop condition.		
Creates start condition.		
Sets the SSmn bit of serial channel start register m (SSm) to 1.	→ The SEMn bit of serial channel enable status register m (SEm) is set to 1 and channel n is enabled to operate.	

**Remark** m: Unit number (m = 0, 1), n: Channel number (n = 0 to 3), r: IIC number (r = 00, 01, 10, 11, 20, 21, 30, 31)  
mn = 00 to 03, 10 to 13

## CHAPTER 13 SERIAL INTERFACE IICA

The number of channels of the serial Interface IICA differs, depending on the product.

	20-pin	24, 25, 30, 32, 36, 40, 44, 48, 52, 56, 64-pin	80, 100, 128-pin
channels	–	1 ch	2 ch

**Caution** Most of the following descriptions in this chapter use the 64-pin products as an example.

### 13.1 Functions of Serial Interface IICA

Serial interface IICA has the following three modes.

#### (1) Operation stop mode

This mode is used when serial transfers are not performed. It can therefore be used to reduce power consumption.

#### (2) I<sup>2</sup>C bus mode (multimaster supported)

This mode is used for 8-bit data transfers with several devices via two lines: a serial clock (SCLA0) line and a serial data bus (SDAA0) line.

This mode complies with the I<sup>2</sup>C bus format and the master device can generate “start condition”, “address”, “transfer direction specification”, “data”, and “stop condition” data to the slave device, via the serial data bus. The slave device automatically detects these received status and data by hardware. This function can simplify the part of application program that controls the I<sup>2</sup>C bus.

Since the SCLA0 and SDAA0 pins are used for open drain outputs, serial interface IICA requires pull-up resistors for the serial clock line and the serial data bus line.

#### (3) Wakeup mode

The STOP mode can be released by generating an interrupt request signal (INTIICA0) when an extension code from the master device or a local address has been received while in STOP mode. This can be set by using the WUP0 bit of IICA control register 01 (IICCTL01).

Figure 13-1 shows a block diagram of serial interface IICA.

Figure 13-1. Block Diagram of Serial Interface IICA

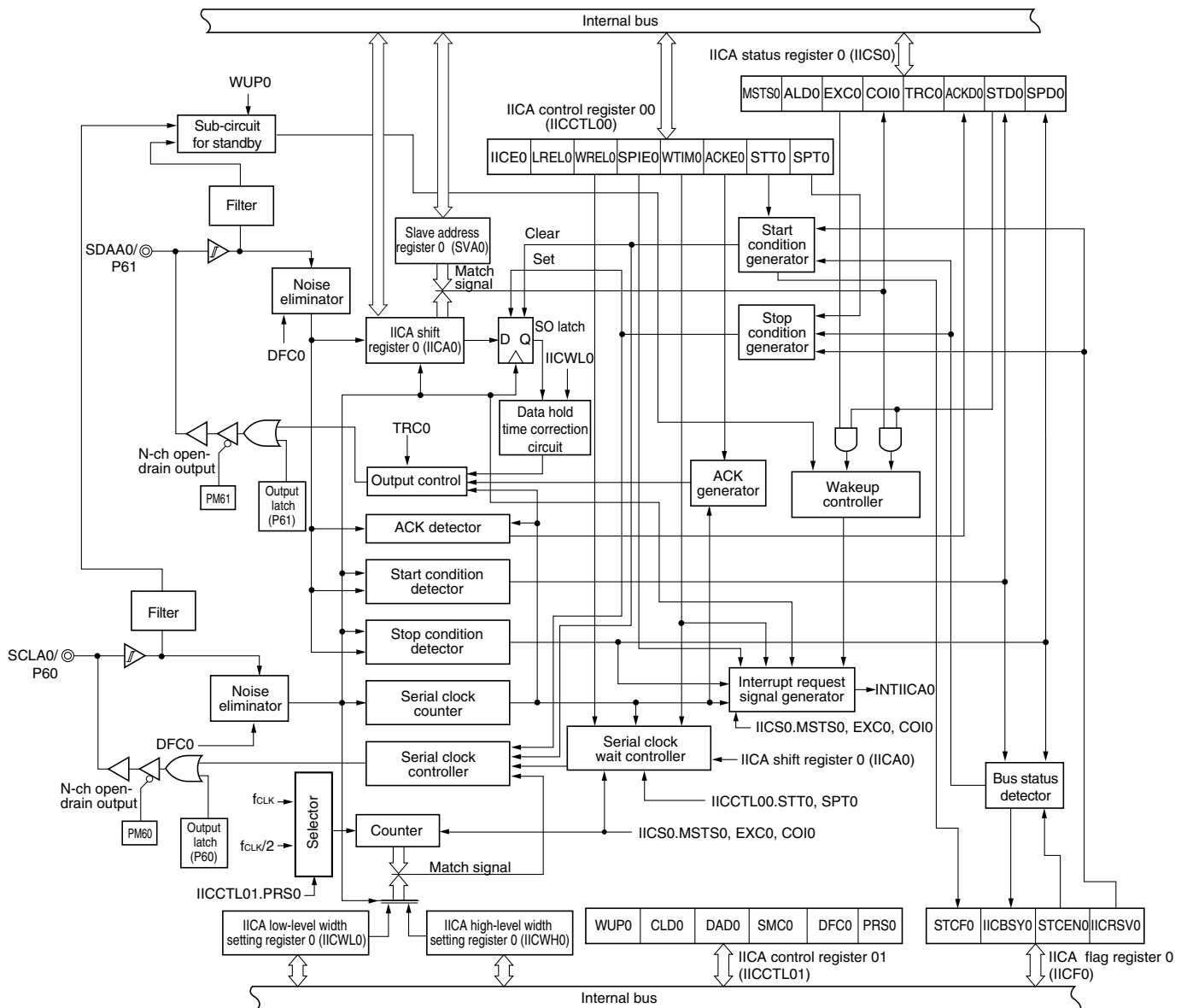
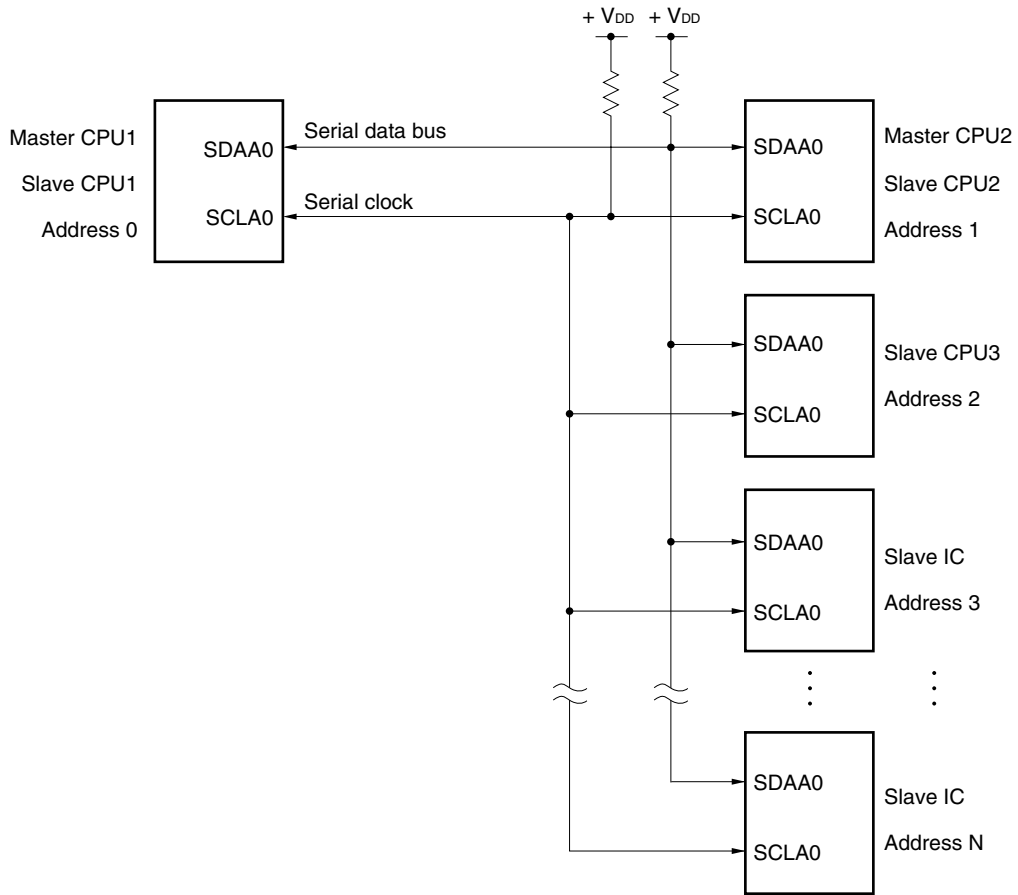


Figure 13-2 shows a serial bus configuration example.

**Figure 13-2. Serial Bus Configuration Example Using I<sup>2</sup>C Bus**





### 13.2 Configuration of Serial Interface IICA

Serial interface IICA includes the following hardware.

**Table 13-1. Configuration of Serial Interface IICA**

Item	Configuration
Registers	IICA shift register 0 (IICA0) Slave address register 0 (SVA0)
Control registers	Peripheral enable register 0 (PER0) IICA control register 00 (IICCTL00) IICA status register 0 (IICS0) IICA flag register 0 (IICF0) IICA control register 01 (IICCTL01) IICA low-level width setting register 0 (IICWL0) IICA high-level width setting register 0 (IICWH0) Port mode register 6 (PM6) Port register 6 (P6)

#### (1) IICA shift register 0 (IICA0)

The IICA0 register is used to convert 8-bit serial data to 8-bit parallel data and vice versa in synchronization with the serial clock. The IICA0 register can be used for both transmission and reception.

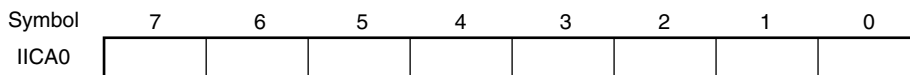
The actual transmit and receive operations can be controlled by writing and reading operations to the IICA0 register. Cancel the wait state and start data transfer by writing data to the IICA0 register during the wait period.

The IICA0 register can be set by an 8-bit memory manipulation instruction.

Reset signal generation clears IICA0 to 00H.

**Figure 13-3. Format of IICA Shift Register 0 (IICA0)**

Address: FFF50H After reset: 00H R/W



- Cautions**
1. Do not write data to the IICA0 register during data transfer.
  2. Write or read the IICA0 register only during the wait period. Accessing the IICA0 register in a communication state other than during the wait period is prohibited. When the device serves as the master, however, the IICA0 register can be written only once after the communication trigger bit (STT0) is set to 1.
  3. When communication is reserved, write data to the IICA0 register after the interrupt triggered by a stop condition is detected.

#### (2) Slave address register 0 (SVA0)

This register stores seven bits of local addresses {A6, A5, A4, A3, A2, A1, A0} when in slave mode.

The SVA0 register can be set by an 8-bit memory manipulation instruction.

However, rewriting to this register is prohibited while STD0 = 1 (while the start condition is detected).

Reset signal generation clears the SVA0 register to 00H.

**Figure 13-4. Format of Slave Address Register 0 (SVA0)**

Address: F0234H After reset: 00H R/W

Symbol	7	6	5	4	3	2	1	0
SVA0	A6	A5	A4	A3	A2	A1	A0	0 <sup>Note</sup>

**Note** Bit 0 is fixed to 0.

**(3) SO latch**

The SO latch is used to retain the SDAA0 pin's output level.

**(4) Wakeup controller**

This circuit generates an interrupt request (INTIICA0) when the address received by this register matches the address value set to the slave address register 0 (SVA0) or when an extension code is received.

**(5) Serial clock counter**

This counter counts the serial clocks that are output or input during transmit/receive operations and is used to verify that 8-bit data was transmitted or received.

**(6) Interrupt request signal generator**

This circuit controls the generation of interrupt request signals (INTIICA0).

An I<sup>2</sup>C interrupt request is generated by the following two triggers.

- Falling edge of eighth or ninth clock of the serial clock (set by the WTIM0 bit)
- Interrupt request generated when a stop condition is detected (set by the SPIE0 bit)

**Remark** WTIM0 bit: Bit 3 of IICA control register 00 (IICCTL00)

SPIE0 bit: Bit 4 of IICA control register 00 (IICCTL00)

**(7) Serial clock controller**

In master mode, this circuit generates the clock output via the SCLA0 pin from a sampling clock.

**(8) Serial clock wait controller**

This circuit controls the wait timing.

**(9) ACK generator, stop condition detector, start condition detector, and ACK detector**

These circuits generate and detect each status.

**(10) Data hold time correction circuit**

This circuit generates the hold time for data corresponding to the falling edge of the serial clock.

**(11) Start condition generator**

This circuit generates a start condition when the STT0 bit is set to 1.

However, in the communication reservation disabled status (IICRSV bit = 1), when the bus is not released (IICBSY bit = 1), start condition requests are ignored and the STCF bit is set to 1.

**(12) Stop condition generator**

This circuit generates a stop condition when the SPT0 bit is set to 1.

**(13) Bus status detector**

This circuit detects whether or not the bus is released by detecting start conditions and stop conditions.

However, as the bus status cannot be detected immediately following operation, the initial status is set by the STCEN bit.

<b>Remark</b>	STT0 bit:	Bit 1 of IICA control register 00 (IICCTL00)
	SPT0 bit:	Bit 0 of IICA control register 00 (IICCTL00)
	IICRSV bit:	Bit 0 of IICA flag register 0 (IICF0)
	IICBSY bit:	Bit 6 of IICA flag register 0 (IICF0)
	STCF bit:	Bit 7 of IICA flag register 0 (IICF0)
	STCEN bit:	Bit 1 of IICA flag register 0 (IICF0)

### 13.3 Registers Controlling Serial Interface IICA

Serial interface IICA is controlled by the following eight registers.

- Peripheral enable register 0 (PER0)
- IICA control register 00 (IICCTL00)
- IICA flag register 0 (IICF0)
- IICA status register 0 (IICS0)
- IICA control register 01 (IICCTL01)
- IICA low-level width setting register 0 (IICWL0)
- IICA high-level width setting register 0 (IICWH0)
- Port mode register 6 (PM6)
- Port register 6 (P6)

#### (1) Peripheral enable register 0 (PER0)

This register is used to enable or disable supplying the clock to the peripheral hardware. Clock supply to a hardware macro that is not used is stopped in order to reduce the power consumption and noise.

When serial interface IICAm is used, be sure to set bits 6, 4 (IICA1EN, IICA0EN) of this register to 1.

The PER0 register can be set by a 1-bit or 8-bit memory manipulation instruction.

Reset signal generation clears this register to 00H.

**Figure 13-5. Format of Peripheral Enable Register 0 (PER0)**

Address: F00F0H After reset: 00H R/W

Symbol	<7>	<6>	<5>	<4>	<3>	<2>	<1>	<0>
PER0	RTCEN <sup>Note 1</sup>	IICA1EN <sup>Note 1</sup>	ADCEN	IICA0EN <sup>Note 2</sup>	SAU1EN <sup>Note 3</sup>	SAU0EN	TAU1EN <sup>Note 1</sup>	TAU0EN

IICAmEN	Control of serial interface IICAm input clock supply
0	Stops input clock supply. <ul style="list-style-type: none"> <li>• SFR used by serial interface IICAm cannot be written.</li> <li>• Serial interface IICAm is in the reset status.</li> </ul>
1	Enables input clock supply. <ul style="list-style-type: none"> <li>• SFR used by serial interface IICAm can be read/written.</li> </ul>

- Notes**
1. 80, 100, and 128-pin products only.
  2. This is not provided in the 20-pin products.
  3. This is not provided in the 20, 24, and 25-pin products.

**Cautions**

1. When setting serial interface IICAm, be sure to set the IICAmEN bit to 1 first. If IICAmEN = 0, writing to a control register of serial interface IICAm is ignored, and, even if the register is read, only the default value is read (except for port mode register 6 (PM6) and port register 6 (P6)).

2. Be sure to clear the following bits to 0.
  - 20-pin products: bits 1, 3, 4, 6
  - 24, 25-pin products: bits 1, 3, 6
  - 30, 32, 36, 40, 44, 48, 52, 64-pin products: bits 1, 6

**Remark** m = 0, 1

**(2) IICA control register 00 (IICCTL00)**

This register is used to enable/stop I<sup>2</sup>C operations, set wait timing, and set other I<sup>2</sup>C operations.

The IICCTL00 register can be set by a 1-bit or 8-bit memory manipulation instruction. However, set the SPIE0, WTIM0, and ACKE0 bits while IICE0 = 0 or during the wait period. These bits can be set at the same time when the IICE0 bit is set from "0" to "1".

Reset signal generation clears this register to 00H.

**Figure 13-6. Format of IICA Control Register 00 (IICCTL00) (1/4)**

Address: F0230H After reset: 00H R/W

Symbol	<7>	<6>	<5>	<4>	<3>	<2>	<1>	<0>
IICCTL00	IICE0	LRELO	WRELO	SPIE0	WTIM0	ACKE0	STT0	SPT0

IICE0	I <sup>2</sup> C operation enable
0	Stop operation. Reset the IICA status register 0 (IICS0) <sup>Note 1</sup> . Stop internal operation.
1	Enable operation.
Be sure to set this bit (1) while the SCLA0 and SDAA0 lines are at high level.	
Condition for clearing (IICE0 = 0)	
<ul style="list-style-type: none"> <li>• Cleared by instruction</li> <li>• Reset</li> </ul>	Condition for setting (IICE0 = 1)
<ul style="list-style-type: none"> <li>• Set by instruction</li> </ul>	

LRELO <sup>Notes 2,3</sup>	Exit from communications
0	Normal operation
1	This exits from the current communications and sets standby mode. This setting is automatically cleared to 0 after being executed. Its uses include cases in which a locally irrelevant extension code has been received. The SCLA0 and SDAA0 lines are set to high impedance. The following flags of IICA control register 00 (IICCTL00) and the IICA status register 0 (IICS0) are cleared to 0. • STT0 • SPT0 • MSTS0 • EXC0 • COI0 • TRC0 • ACKD0 • STD0
The standby mode following exit from communications remains in effect until the following communications entry conditions are met.	
<ul style="list-style-type: none"> <li>• After a stop condition is detected, restart is in master mode.</li> <li>• An address match or extension code reception occurs after the start condition.</li> </ul>	
Condition for clearing (LRELO = 0)	
<ul style="list-style-type: none"> <li>• Automatically cleared after execution</li> <li>• Reset</li> </ul>	Condition for setting (LRELO = 1)
<ul style="list-style-type: none"> <li>• Set by instruction</li> </ul>	

WRELO <sup>Notes 2,3</sup>	Wait cancellation
0	Do not cancel wait
1	Cancel wait. This setting is automatically cleared after wait is canceled.
When the WRELO bit is set (wait canceled) during the wait period at the ninth clock pulse in the transmission status (TRC0 = 1), the SDAA0 line goes into the high impedance state (TRC0 = 0).	
Condition for clearing (WRELO = 0)	
<ul style="list-style-type: none"> <li>• Automatically cleared after execution</li> <li>• Reset</li> </ul>	Condition for setting (WRELO = 1)
<ul style="list-style-type: none"> <li>• Set by instruction</li> </ul>	

- Notes**
1. The IICA status register 0 (IICS0), the STCF and IICBSY bits of the IICA flag register 0 (IICF0), and the CLD0 and DAD0 bits of IICA control register 01 (IICCTL01) are reset.
  2. The signal of this bit is invalid while IICE0 is 0.
  3. When the LRELO and WRELO bits are read, 0 is always read.

**Caution** If the operation of I<sup>2</sup>C is enabled (IICE0 = 1) when the SCLA0 line is high level, the SDAA0 line is low level, and the digital filter is turned on (DFC0 bit of IICCTL01 register = 1), a start condition will be inadvertently detected immediately. In this case, set (1) the LRELO bit by using a 1-bit memory manipulation instruction immediately after enabling operation of I<sup>2</sup>C (IICE0 = 1).

Figure 13-6. Format of IICA Control Register 00 (IICCTL00) (2/4)

SPIE0 <sup>Note 1</sup>	Enable/disable generation of interrupt request when stop condition is detected	
0	Disable	
1	Enable	
If the WUP0 bit of IICA control register 01 (IICCTL01) is 1, no stop condition interrupt will be generated even if SPIE0 = 1.		
Condition for clearing (SPIE0 = 0)		Condition for setting (SPIE0 = 1)
<ul style="list-style-type: none"> <li>• Cleared by instruction</li> <li>• Reset</li> </ul>		<ul style="list-style-type: none"> <li>• Set by instruction</li> </ul>

WTIM0 <sup>Note 1</sup>	Control of wait and interrupt request generation	
0	Interrupt request is generated at the eighth clock's falling edge. Master mode: After output of eight clocks, clock output is set to low level and wait is set. Slave mode: After input of eight clocks, the clock is set to low level and wait is set for master device.	
1	Interrupt request is generated at the ninth clock's falling edge. Master mode: After output of nine clocks, clock output is set to low level and wait is set. Slave mode: After input of nine clocks, the clock is set to low level and wait is set for master device.	
An interrupt is generated at the falling edge of the ninth clock during address transfer independently of the setting of this bit. The setting of this bit is valid when the address transfer is completed. When in master mode, a wait is inserted at the falling edge of the ninth clock during address transfers. For a slave device that has received a local address, a wait is inserted at the falling edge of the ninth clock after an acknowledge ( $\overline{ACK}$ ) is issued. However, when the slave device has received an extension code, a wait is inserted at the falling edge of the eighth clock.		
Condition for clearing (WTIM0 = 0)		Condition for setting (WTIM0 = 1)
<ul style="list-style-type: none"> <li>• Cleared by instruction</li> <li>• Reset</li> </ul>		<ul style="list-style-type: none"> <li>• Set by instruction</li> </ul>

ACKE0 <sup>Notes 1, 2</sup>	Acknowledgment control	
0	Disable acknowledgment.	
1	Enable acknowledgment. During the ninth clock period, the SDAA0 line is set to low level.	
Condition for clearing (ACKE0 = 0)		Condition for setting (ACKE0 = 1)
<ul style="list-style-type: none"> <li>• Cleared by instruction</li> <li>• Reset</li> </ul>		<ul style="list-style-type: none"> <li>• Set by instruction</li> </ul>

- Notes**
1. The signal of this bit is invalid while IICE0 is 0. Set this bit during that period.
  2. The set value is invalid during address transfer and if the code is not an extension code.  
When the device serves as a slave and the addresses match, an acknowledgment is generated regardless of the set value.

Figure 13-6. Format of IICA Control Register 00 (IICCTL00) (3/4)

STT0 <sup>Note</sup>	Start condition trigger				
0	Do not generate a start condition.				
1	<p>When bus is released (in standby state, when IICBSY = 0):                      If this bit is set (1), a start condition is generated (startup as the master).</p> <p>When a third party is communicating:</p> <ul style="list-style-type: none"> <li>• When communication reservation function is enabled (IICRSV = 0)                              Functions as the start condition reservation flag. When set to 1, automatically generates a start condition after the bus is released.</li> <li>• When communication reservation function is disabled (IICRSV = 1)                              Even if this bit is set (1), the STT0 bit is cleared and the STT0 clear flag (STCF) is set (1). No start condition is generated.</li> </ul> <p>In the wait state (when master device):                      Generates a restart condition after releasing the wait.</p>				
<p>Cautions concerning set timing</p> <ul style="list-style-type: none"> <li>• For master reception: Cannot be set to 1 during transfer. Can be set to 1 only in the waiting period when the ACKE0 bit has been cleared to 0 and slave has been notified of final reception.</li> <li>• For master transmission: A start condition cannot be generated normally during the acknowledge period. Set to 1 during the wait period that follows output of the ninth clock.</li> <li>• Cannot be set to 1 at the same time as stop condition trigger (SPT0).</li> <li>• Once STT0 is set (1), setting it again (1) before the clear condition is met is not allowed.</li> </ul>					
<table border="1"> <thead> <tr> <th>Condition for clearing (STT0 = 0)</th> <th>Condition for setting (STT0 = 1)</th> </tr> </thead> <tbody> <tr> <td> <ul style="list-style-type: none"> <li>• Cleared by setting the STT0 bit to 1 while communication reservation is prohibited.</li> <li>• Cleared by loss in arbitration</li> <li>• Cleared after start condition is generated by master device</li> <li>• Cleared by LREL0 = 1 (exit from communications)</li> <li>• When IICE0 = 0 (operation stop)</li> <li>• Reset</li> </ul> </td> <td> <ul style="list-style-type: none"> <li>• Set by instruction</li> </ul> </td> </tr> </tbody> </table>		Condition for clearing (STT0 = 0)	Condition for setting (STT0 = 1)	<ul style="list-style-type: none"> <li>• Cleared by setting the STT0 bit to 1 while communication reservation is prohibited.</li> <li>• Cleared by loss in arbitration</li> <li>• Cleared after start condition is generated by master device</li> <li>• Cleared by LREL0 = 1 (exit from communications)</li> <li>• When IICE0 = 0 (operation stop)</li> <li>• Reset</li> </ul>	<ul style="list-style-type: none"> <li>• Set by instruction</li> </ul>
Condition for clearing (STT0 = 0)	Condition for setting (STT0 = 1)				
<ul style="list-style-type: none"> <li>• Cleared by setting the STT0 bit to 1 while communication reservation is prohibited.</li> <li>• Cleared by loss in arbitration</li> <li>• Cleared after start condition is generated by master device</li> <li>• Cleared by LREL0 = 1 (exit from communications)</li> <li>• When IICE0 = 0 (operation stop)</li> <li>• Reset</li> </ul>	<ul style="list-style-type: none"> <li>• Set by instruction</li> </ul>				

<R>

**Note** The signal of this bit is invalid while IICE0 is 0.

**Remarks** 1. Bit 1 (STT0) becomes 0 when it is read after data setting.  
 2. IICRSV: Bit 0 of IIC flag register 0 (IICF0)  
 STCF: Bit 7 of IIC flag register 0 (IICF0)



Figure 13-6. Format of IICA Control Register 00 (IICCTL00) (4/4)

SPT0	Stop condition trigger	
0	Stop condition is not generated.	
1	Stop condition is generated (termination of master device's transfer).	
<p>Cautions concerning set timing</p> <ul style="list-style-type: none"> <li>• For master reception:     Cannot be set to 1 during transfer.                                   Can be set to 1 only in the waiting period when the ACKE0 bit has been cleared to 0 and slave has been notified of final reception.</li> <li>• For master transmission: A stop condition cannot be generated normally during the acknowledge period.                                   Therefore, set it during the wait period that follows output of the ninth clock.</li> <li>• Cannot be set to 1 at the same time as start condition trigger (STT0).</li> <li>• The SPT0 bit can be set to 1 only when in master mode.</li> <li>• When the WTIM0 bit has been cleared to 0, if the SPT0 bit is set to 1 during the wait period that follows output of eight clocks, note that a stop condition will be generated during the high-level period of the ninth clock. The WTIM0 bit should be changed from 0 to 1 during the wait period following the output of eight clocks, and the SPT0 bit should be set to 1 during the wait period that follows the output of the ninth clock.</li> <li>• Once STT0 is set (1), setting it again (1) before the clear condition is met is not allowed.</li> </ul>		
Condition for clearing (SPT0 = 0)		Condition for setting (SPT0 = 1)
<ul style="list-style-type: none"> <li>• Cleared by loss in arbitration</li> <li>• Automatically cleared after stop condition is detected</li> <li>• Cleared by LREL0 = 1 (exit from communications)</li> <li>• When IICE0 = 0 (operation stop)</li> <li>• Reset</li> </ul>		<ul style="list-style-type: none"> <li>• Set by instruction</li> </ul>

<R>

**Caution** When bit 3 (TRC0) of the IICA status register 0 (IICS0) is set to 1 (transmission status), bit 5 (WREL0) of IICA control register 00 (IICCTL00) is set to 1 during the ninth clock and wait is canceled, after which the TRC0 bit is cleared (reception status) and the SDAA0 line is set to high impedance. Release the wait performed while the TRC0 bit is 1 (transmission status) by writing to the IICA shift register 0.

**Remark** Bit 0 (SPT0) becomes 0 when it is read after data setting.

**(3) IICA status register 0 (IICS0)**

This register indicates the status of I<sup>2</sup>C.

The IICS0 register is read by a 1-bit or 8-bit memory manipulation instruction only when STT0 = 1 and during the wait period.

Reset signal generation clears this register to 00H.

**Caution** Reading the IICS0 register while the address match wakeup function is enabled (WUP0 = 1) in STOP mode is prohibited. When the WUP0 bit is changed from 1 to 0 (wakeup operation is stopped), regardless of the INTIICA0 interrupt request, the change in status is not reflected until the next start condition or stop condition is detected. To use the wakeup function, therefore, enable (SPIE0 = 1) the interrupt generated by detecting a stop condition and read the IICS0 register after the interrupt has been detected.

**Remark** STT0: bit 1 of IICA control register 00 (IICCTL00)  
 WUP0: bit 7 of IICA control register 01 (IICCTL01)

**Figure 13-7. Format of IICA Status Register 0 (IICS0) (1/3)**

Address: FFF51H      After reset: 00H      R

Symbol	<7>	<6>	<5>	<4>	<3>	<2>	<1>	<0>
IICS0	MSTS0	ALD0	EXC0	COI0	TRC0	ACKD0	STD0	SPD0

MSTS0	Master status check flag
0	Slave device status or communication standby status
1	Master device communication status
Condition for clearing (MSTS0 = 0)	
<ul style="list-style-type: none"> <li>• When a stop condition is detected</li> <li>• When ALD0 = 1 (arbitration loss)</li> <li>• Cleared by LRELO = 1 (exit from communications)</li> <li>• When the IICE0 bit changes from 1 to 0 (operation stop)</li> <li>• Reset</li> </ul>	
Condition for setting (MSTS0 = 1)	
<ul style="list-style-type: none"> <li>• When a start condition is generated</li> </ul>	

ALD0	Detection of arbitration loss
0	This status means either that there was no arbitration or that the arbitration result was a "win".
1	This status indicates the arbitration result was a "loss". The MSTS0 bit is cleared.
Condition for clearing (ALD0 = 0)	
<ul style="list-style-type: none"> <li>• Automatically cleared after the IICS0 register is read<sup>Note</sup></li> <li>• When the IICE0 bit changes from 1 to 0 (operation stop)</li> <li>• Reset</li> </ul>	
Condition for setting (ALD0 = 1)	
<ul style="list-style-type: none"> <li>• When the arbitration result is a "loss".</li> </ul>	

**Note** This register is also cleared when a 1-bit memory manipulation instruction is executed for bits other than the IICS0 register. Therefore, when using the ALD0 bit, read the data of this bit before the data of the other bits.

**Remark** LRELO: Bit 6 of IICA control register 00 (IICCTL00)  
 IICE0: Bit 7 of IICA control register 00 (IICCTL00)

Figure 13-7. Format of IICA Status Register 0 (IICS0) (2/3)

EXC0	Detection of extension code reception	
0	Extension code was not received.	
1	Extension code was received.	
Condition for clearing (EXC0 = 0)		Condition for setting (EXC0 = 1)
<ul style="list-style-type: none"> <li>When a start condition is detected</li> <li>When a stop condition is detected</li> <li>Cleared by LREL0 = 1 (exit from communications)</li> <li>When the IICE0 bit changes from 1 to 0 (operation stop)</li> <li>Reset</li> </ul>		<ul style="list-style-type: none"> <li>When the higher four bits of the received address data is either "0000" or "1111" (set at the rising edge of the eighth clock).</li> </ul>

COI0	Detection of matching addresses	
0	Addresses do not match.	
1	Addresses match.	
Condition for clearing (COI0 = 0)		Condition for setting (COI0 = 1)
<ul style="list-style-type: none"> <li>When a start condition is detected</li> <li>When a stop condition is detected</li> <li>Cleared by LREL0 = 1 (exit from communications)</li> <li>When the IICE0 bit changes from 1 to 0 (operation stop)</li> <li>Reset</li> </ul>		<ul style="list-style-type: none"> <li>When the received address matches the local address (slave address register 0 (SVA0)) (set at the rising edge of the eighth clock).</li> </ul>

TRC0	Detection of transmit/receive status	
0	Receive status (other than transmit status). The SDAA0 line is set for high impedance.	
1	Transmit status. The value in the SO0 latch is enabled for output to the SDAA0 line (valid starting at the falling edge of the first byte's ninth clock).	
Condition for clearing (TRC0 = 0)		Condition for setting (TRC0 = 1)
<p>&lt;Both master and slave&gt;</p> <ul style="list-style-type: none"> <li>When a stop condition is detected</li> <li>Cleared by LREL0 = 1 (exit from communications)</li> <li>When the IICE0 bit changes from 1 to 0 (operation stop)</li> <li>Cleared by WREL0 = 1<sup>Note</sup> (wait cancel)</li> <li>When the ALD0 bit changes from 0 to 1 (arbitration loss)</li> <li>Reset</li> <li>When not used for communication (MSTS0, EXC0, COI0 = 0)</li> </ul> <p>&lt;Master&gt;</p> <ul style="list-style-type: none"> <li>When "1" is output to the first byte's LSB (transfer direction specification bit)</li> </ul> <p>&lt;Slave&gt;</p> <ul style="list-style-type: none"> <li>When a start condition is detected</li> <li>When "0" is input to the first byte's LSB (transfer direction specification bit)</li> </ul>		<p>&lt;Master&gt;</p> <ul style="list-style-type: none"> <li>When a start condition is generated</li> <li>When 0 (master transmission) is output to the LSB (transfer direction specification bit) of the first byte (during address transfer)</li> </ul> <p>&lt;Slave&gt;</p> <ul style="list-style-type: none"> <li>When 1 (slave transmission) is input to the LSB (transfer direction specification bit) of the first byte from the master (during address transfer)</li> </ul>

**Note** When bit 3 (TRC0) of the IICA status register 0 (IICS0) is set to 1 (transmission status), bit 5 (WREL0) of IICA control register 00 (IICCTL00) is set to 1 during the ninth clock and wait is canceled, after which the TRC0 bit is cleared (reception status) and the SDAA0 line is set to high impedance. Release the wait performed while the TRC0 bit is 1 (transmission status) by writing to the IICA shift register 0.

**Remark** LREL0: Bit 6 of IICA control register 00 (IICCTL00)  
 IICE0: Bit 7 of IICA control register 00 (IICCTL00)

**Figure 13-7. Format of IICA Status Register 0 (IICS0) (3/3)**

ACKD0	Detection of acknowledge ( $\overline{\text{ACK}}$ )	
0	Acknowledge was not detected.	
1	Acknowledge was detected.	
Condition for clearing (ACKD0 = 0)		Condition for setting (ACKD0 = 1)
<ul style="list-style-type: none"> <li>• When a stop condition is detected</li> <li>• At the rising edge of the next byte's first clock</li> <li>• Cleared by LREL0 = 1 (exit from communications)</li> <li>• When the IICE0 bit changes from 1 to 0 (operation stop)</li> <li>• Reset</li> </ul>		<ul style="list-style-type: none"> <li>• After the SDA0 line is set to low level at the rising edge of SCLA0 line's ninth clock</li> </ul>

STD0	Detection of start condition	
0	Start condition was not detected.	
1	Start condition was detected. This indicates that the address transfer period is in effect.	
Condition for clearing (STD0 = 0)		Condition for setting (STD0 = 1)
<ul style="list-style-type: none"> <li>• When a stop condition is detected</li> <li>• At the rising edge of the next byte's first clock following address transfer</li> <li>• Cleared by LREL0 = 1 (exit from communications)</li> <li>• When the IICE0 bit changes from 1 to 0 (operation stop)</li> <li>• Reset</li> </ul>		<ul style="list-style-type: none"> <li>• When a start condition is detected</li> </ul>

SPD0	Detection of stop condition	
0	Stop condition was not detected.	
1	Stop condition was detected. The master device's communication is terminated and the bus is released.	
Condition for clearing (SPD0 = 0)		Condition for setting (SPD0 = 1)
<ul style="list-style-type: none"> <li>• At the rising edge of the address transfer byte's first clock following setting of this bit and detection of a start condition</li> <li>• When the WUP0 bit changes from 1 to 0</li> <li>• When the IICE0 bit changes from 1 to 0 (operation stop)</li> <li>• Reset</li> </ul>		<ul style="list-style-type: none"> <li>• When a stop condition is detected</li> </ul>

<R>

**Remark** LREL0: Bit 6 of IICA control register 00 (IICCTL00)  
 IICE0: Bit 7 of IICA control register 00 (IICCTL00)

**(4) IICA flag register 0 (IICF0)**

This register sets the operation mode of I<sup>2</sup>C and indicates the status of the I<sup>2</sup>C bus.  
 The IICF0 register can be set by a 1-bit or 8-bit memory manipulation instruction. However, the STT0 clear flag (STCF) and I<sup>2</sup>C bus status flag (IICBSY) bits are read-only.  
 The IICRSV bit can be used to enable/disable the communication reservation function.  
 The STCEN bit can be used to set the initial value of the IICBSY bit.  
 The IICRSV and STCEN bits can be written only when the operation of I<sup>2</sup>C is disabled (bit 7 (IICE0) of IICA control register 00 (IICCTL00) = 0). When operation is enabled, the IICF0 register can be read.  
 Reset signal generation clears this register to 00H.

Figure 13-8. Format of IICA Flag Register 0 (IICF0)

Address: FFF52H    After reset: 00H    R/W<sup>Note</sup>

Symbol	<7>	<6>	5	4	3	2	<1>	<0>
IICF0	STCF0	IICBSY0	0	0	0	0	STCEN0	IICRSV0

STCF0	STT0 clear flag	
0	Generate start condition	
1	Start condition generation unsuccessful: clear the STT0 flag	
Condition for clearing (STCF0 = 0)		Condition for setting (STCF0 = 1)
<ul style="list-style-type: none"> <li>Cleared by STT0 = 1</li> <li>When IICE0 = 0 (operation stop)</li> <li>Reset</li> </ul>		<ul style="list-style-type: none"> <li>Generating start condition unsuccessful and the STT0 bit cleared to 0 when communication reservation is disabled (IICRSV0 = 1).</li> </ul>

IICBSY0	I <sup>2</sup> C bus status flag	
0	Bus release status (communication initial status when STCEN0 = 1)	
1	Bus communication status (communication initial status when STCEN0 = 0)	
Condition for clearing (IICBSY0 = 0)		Condition for setting (IICBSY0 = 1)
<ul style="list-style-type: none"> <li>Detection of stop condition</li> <li>When IICE0 = 0 (operation stop)</li> <li>Reset</li> </ul>		<ul style="list-style-type: none"> <li>Detection of start condition</li> <li>Setting of the IICE0 bit when STCEN0 = 0</li> </ul>

STCEN0	Initial start enable trigger	
0	After operation is enabled (IICE0 = 1), enable generation of a start condition upon detection of a stop condition.	
1	After operation is enabled (IICE0 = 1), enable generation of a start condition without detecting a stop condition.	
Condition for clearing (STCEN0 = 0)		Condition for setting (STCEN0 = 1)
<ul style="list-style-type: none"> <li>Cleared by instruction</li> <li>Detection of start condition</li> <li>Reset</li> </ul>		<ul style="list-style-type: none"> <li>Set by instruction</li> </ul>

IICRSV0	Communication reservation function disable bit	
0	Enable communication reservation	
1	Disable communication reservation	
Condition for clearing (IICRSV0 = 0)		Condition for setting (IICRSV0 = 1)
<ul style="list-style-type: none"> <li>Cleared by instruction</li> <li>Reset</li> </ul>		<ul style="list-style-type: none"> <li>Set by instruction</li> </ul>

**Note** Bits 6 and 7 are read-only.

- Cautions**
1. Write to the STCEN bit only when the operation is stopped (IICE0 = 0).
  2. As the bus release status (IICBSY = 0) is recognized regardless of the actual bus status when STCEN = 1, when generating the first start condition (STT0 = 1), it is necessary to verify that no third party communications are in progress in order to prevent such communications from being destroyed.
  3. Write to IICRSV only when the operation is stopped (IICE0 = 0).

**Remark** STT0: Bit 1 of IICA control register 00 (IICCTL00)  
IICE0: Bit 7 of IICA control register 00 (IICCTL00)

**(5) IICA control register 01 (IICCTL01)**

This register is used to set the operation mode of I<sup>2</sup>C and detect the statuses of the SCLA0 and SDAA0 pins. The IICCTL01 register can be set by a 1-bit or 8-bit memory manipulation instruction. However, the CLD0 and DAD0 bits are read-only.

Set the IICCTL01 register, except the WUP0 bit, while operation of I<sup>2</sup>C is disabled (bit 7 (IICE0) of IICA control register 00 (IICCTL00) is 0).

Reset signal generation clears this register to 00H.

**Figure 13-9. Format of IICA Control Register 01 (IICCTL01) (1/2)**

Address: F0231H    After reset: 00H    R/W<sup>Note 1</sup>

Symbol	7	6	<5>	<4>	<3>	<2>	1	<0>
IICCTL01	WUP0	0	CLD0	DAD0	SMC0	DFC0	0	PRS0

WUP0	Control of address match wakeup
0	Stops operation of address match wakeup function in STOP mode.
1	Enables operation of address match wakeup function in STOP mode.
<p>To shift to STOP mode when WUP0 = 1, execute the STOP instruction at least three clocks after setting (1) the WUP0 bit (see <b>Figure 13-22 Flow When Setting WUP0 = 1</b>).</p> <p>Clear (0) the WUP0 bit after the address has matched or an extension code has been received. The subsequent communication can be entered by the clearing (0) WUP0 bit. (The wait must be released and transmit data must be written after the WUP0 bit has been cleared (0).)</p> <p>The interrupt timing when the address has matched or when an extension code has been received, while WUP0 = 1, is identical to the interrupt timing when WUP0 = 0. (A delay of the difference of sampling by the clock will occur.) Furthermore, when WUP0 = 1, a stop condition interrupt is not generated even if the SPIE0 bit is set to 1.</p> <p>When WUP0 = 0 is set by a source other than an interrupt from serial interface IICA, operation as the master device cannot be performed until the subsequent start condition or stop condition is detected. Do not output a start condition by setting (1) the STT0 bit, without waiting for the detection of the subsequent start condition or stop condition.</p>	
Condition for clearing (WUP0 = 0)	Condition for setting (WUP0 = 1)
<ul style="list-style-type: none"> <li>• Cleared by instruction (after address match or extension code reception)</li> </ul>	<ul style="list-style-type: none"> <li>• Set by instruction (when the MST0, EXC0, and COI0 bits are "0", and the STD0 bit also "0" (communication not entered))<sup>Note 2</sup></li> </ul>

- Notes 1.** Bits 4 and 5 are read-only.
- 2.** The status of the IICA status register 0 (IICS0) must be checked and the WUP0 bit must be set during the period shown below.

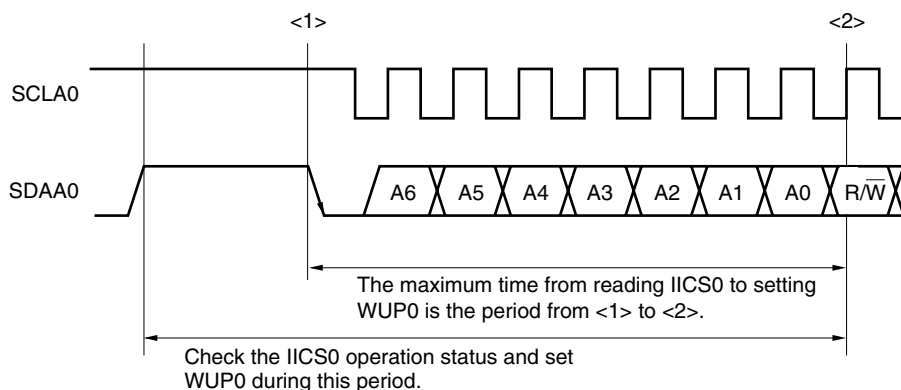


Figure 13-9. Format of IICA Control Register 01 (IICCTL01) (2/2)

CLD0	Detection of SCLA0 pin level (valid only when IICE0 = 1)	
0	The SCLA0 pin was detected at low level.	
1	The SCLA0 pin was detected at high level.	
Condition for clearing (CLD0 = 0)		Condition for setting (CLD0 = 1)
<ul style="list-style-type: none"> <li>• When the SCLA0 pin is at low level</li> <li>• When IICE0 = 0 (operation stop)</li> <li>• Reset</li> </ul>		<ul style="list-style-type: none"> <li>• When the SCLA0 pin is at high level</li> </ul>

DAD0	Detection of SDAA0 pin level (valid only when IICE0 = 1)	
0	The SDAA0 pin was detected at low level.	
1	The SDAA0 pin was detected at high level.	
Condition for clearing (DAD0 = 0)		Condition for setting (DAD0 = 1)
<ul style="list-style-type: none"> <li>• When the SDAA0 pin is at low level</li> <li>• When IICE0 = 0 (operation stop)</li> <li>• Reset</li> </ul>		<ul style="list-style-type: none"> <li>• When the SDAA0 pin is at high level</li> </ul>

SMC0	Operation mode switching	
0	Operates in standard mode (fastest transfer rate: 100 kbps).	
1	Operates in fast mode (fastest transfer rate: 400 kbps) or fast mode plus (fastest transfer rate: 1 Mbps).	

DFC0	Digital filter operation control	
0	Digital filter off.	
1	Digital filter on.	
<p>Digital filter can be used only in fast mode.          In fast mode, the transfer clock does not vary, regardless of the DFC0 bit being set (1) or cleared (0).          The digital filter is used for noise elimination in fast mode.</p>		

PRS0	Division of the operation clock	
0	Selects $f_{CLK}$ as operation clock.	
1	Selects $f_{CLK}/2$ as operation clock.	

**Caution** The fastest operation frequency of the operation clock of the serial interface IICA is 20 MHz (Max.). If the  $f_{CLK}$  exceeds 20 MHz, set the clock to  $f_{CLK}/2$  by setting the PRS0 bit to 1.

**Remark** IICE0: Bit 7 of IICA control register 00 (IICCTL00)

**(6) IICA low-level width setting register 0 (IICWL0)**

This register is used to set the low-level width ( $t_{LOW}$ ) and data hold time ( $t_{HD:DAT}$ ) of the SCLA0 pin signal that is output by serial interface IICA. The data hold time is decided by value the higher 6 bits of IICWL register.

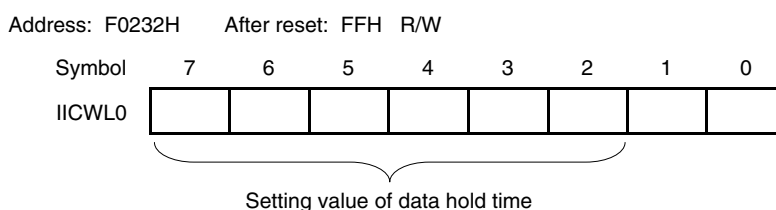
The IICWL0 register can be set by an 8-bit memory manipulation instruction.

Set the IICWL0 register while operation of I<sup>2</sup>C is disabled (bit 7 (IICE0) of IICA control register 00 (IICCTL00) is 0).

Reset signal generation sets this register to FFH.

For details about setting the IICWL0 register, see **13.4.2 Setting transfer clock by using IICWL0 and IICWH0 registers.**

**Figure 13-10. Format of IICA Low-Level Width Setting Register 0 (IICWL0)**



**(7) IICA high-level width setting register 0 (IICWH0)**

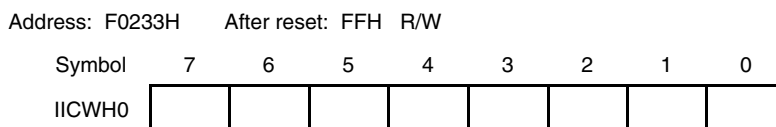
This register is used to set the high-level width of the SCLA0 pin signal that is output by serial interface IICA.

The IICWH0 register can be set by an 8-bit memory manipulation instruction.

Set the IICWH0 register while operation of I<sup>2</sup>C is disabled (bit 7 (IICE0) of IICA control register 00 (IICCTL00) is 0).

Reset signal generation sets this register to FFH.

**Figure 13-11. Format of IICA High-Level Width Setting Register 0 (IICWH0)**



**Remark** For how to set the transfer clock by using the IICWL0 and IICWH0 registers, see **13.4.2 Setting transfer clock by using IICWL0 and IICWH0 registers.**



**(8) Port mode register 6 (PM6)**

This register sets the input/output of port 6 in 1-bit units.

When using the P60/SCLA0 pin as clock I/O and the P61/SDAA0 pin as serial data I/O, clear PM60 and PM61, and the output latches of P60 and P61 to 0.

Set the IICE0 bit (bit 7 of IICA control register 00 (IICCTL00)) to 1 before setting the output mode because the P60/SCLA0 and P61/SDAA0 pins output a low level (fixed) when the IICE0 bit is 0.

The PM6 register can be set by a 1-bit or 8-bit memory manipulation instruction.

Reset signal generation sets this register to FFH.

**Figure 13-12. Format of Port Mode Register 6 (PM6)**

Address: FFF26H    After reset: FFH    R/W

Symbol	7	6	5	4	3	2	1	0
PM6	1	1	1	1	PM63	PM62	PM61	PM60

PM6n	P6n pin I/O mode selection (n = 0 to 3)
0	Output mode (output buffer on)
1	Input mode (output buffer off)

## 13.4 I<sup>2</sup>C Bus Mode Functions

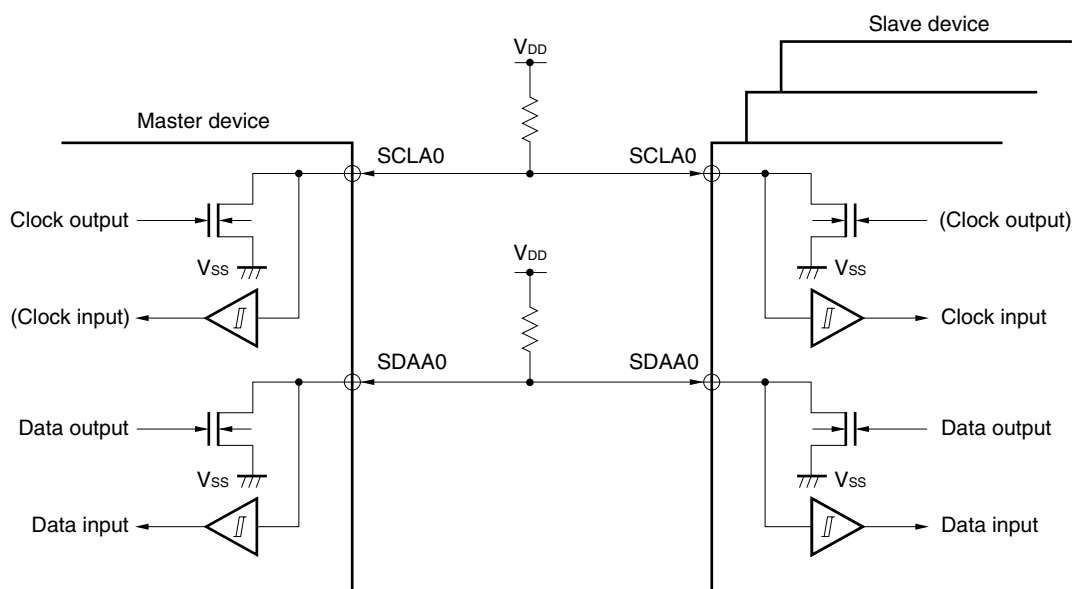
### 13.4.1 Pin configuration

The serial clock pin (SCLA0) and the serial data bus pin (SDAA0) are configured as follows.

- (1) SCLA0 .... This pin is used for serial clock input and output.  
This pin is an N-ch open-drain output for both master and slave devices. Input is Schmitt input.
- (2) SDAA0 .... This pin is used for serial data input and output.  
This pin is an N-ch open-drain output for both master and slave devices. Input is Schmitt input.

Since outputs from the serial clock line and the serial data bus line are N-ch open-drain outputs, an external pull-up resistor is required.

**Figure 13-13. Pin Configuration Diagram**



### 13.4.2 Setting transfer clock by using IICWLO and IICWH0 registers

#### (1) Setting transfer clock on master side

$$\text{Transfer clock} = \frac{f_{\text{CLK}}}{\text{IICWLO} + \text{IICWH0} + f_{\text{CLK}}(t_{\text{R}} + t_{\text{F}})}$$

At this time, the optimal setting values of the IICWLO and IICWH0 registers are as follows.  
(The fractional parts of all setting values are rounded up.)

- When the fast mode

$$\begin{aligned} \text{IICWLO} &= \frac{0.52}{\text{Transfer clock}} \times f_{\text{CLK}} \\ \text{IICWH0} &= \left( \frac{0.48}{\text{Transfer clock}} - t_{\text{R}} - t_{\text{F}} \right) \times f_{\text{CLK}} \end{aligned}$$

- When the normal mode

$$\begin{aligned} \text{IICWLO} &= \frac{0.47}{\text{Transfer clock}} \times f_{\text{CLK}} \\ \text{IICWH0} &= \left( \frac{0.53}{\text{Transfer clock}} - t_{\text{R}} - t_{\text{F}} \right) \times f_{\text{CLK}} \end{aligned}$$

- <R>
  - When the fast mode plus

$$\begin{aligned} \text{IICWLO} &= \frac{0.50}{\text{Transfer clock}} \times f_{\text{CLK}} \\ \text{IICWH0} &= \left( \frac{0.50}{\text{Transfer clock}} - t_{\text{R}} - t_{\text{F}} \right) \times f_{\text{CLK}} \end{aligned}$$

#### (2) Setting IICWLO and IICWH0 registers on slave side

(The fractional parts of all setting values are truncated.)

- When the fast mode

$$\begin{aligned} \text{IICWLO} &= 1.3 \mu\text{s} \times f_{\text{CLK}} \\ \text{IICWH0} &= (1.2 \mu\text{s} - t_{\text{R}} - t_{\text{F}}) \times f_{\text{CLK}} \end{aligned}$$

- When the normal mode

$$\begin{aligned} \text{IICWLO} &= 4.7 \mu\text{s} \times f_{\text{CLK}} \\ \text{IICWH0} &= (5.3 \mu\text{s} - t_{\text{R}} - t_{\text{F}}) \times f_{\text{CLK}} \end{aligned}$$

- <R>
  - When the fast mode plus

$$\begin{aligned} \text{IICWLO} &= 0.50 \mu\text{s} \times f_{\text{CLK}} \\ \text{IICWH0} &= (0.50 \mu\text{s} - t_{\text{R}} - t_{\text{F}}) \times f_{\text{CLK}} \end{aligned}$$

(**Caution** and **Remarks** are listed on the next page.)

**Caution** Note the minimum  $f_{CLK}$  operation frequency when setting the transfer clock. The minimum  $f_{CLK}$  operation frequency for serial interface IICA is determined according to the mode.

**Fast mode:**  $f_{CLK} = 3.5 \text{ MHz (MIN.)}$

**Fast mode plus:**  $f_{CLK} = 10 \text{ MHz (MIN.)}$

**Normal mode:**  $f_{CLK} = 1 \text{ MHz (MIN.)}$

In addition, the fastest operation frequency of the operation clock of the serial interface IICA is 20 MHz (Max.). If the  $f_{CLK}$  exceeds 20 MHz, set the clock to  $f_{CLK}/2$  by setting the PRS0 bit of IICCTL01 register to 1.

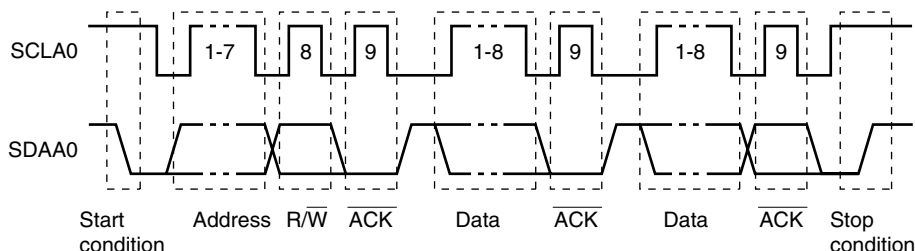
**Remarks 1.** Calculate the rise time ( $t_R$ ) and fall time ( $t_F$ ) of the SDAA0 and SCLA0 signals separately, because they differ depending on the pull-up resistance and wire load.

- 2.**
- |             |  |
|-------------|--|
| IICWL0:     | IICA low-level width setting register 0  |
| IICWH0:     | IICA high-level width setting register 0 |
| $t_F$ :     | SDAA0 and SCLA0 signal falling times     |
| $t_R$ :     | SDAA0 and SCLA0 signal rising times      |
| $f_{CLK}$ : | CPU/peripheral hardware clock frequency  |

### 13.5 I<sup>2</sup>C Bus Definitions and Control Methods

The following section describes the I<sup>2</sup>C bus's serial data communication format and the signals used by the I<sup>2</sup>C bus. Figure 13-14 shows the transfer timing for the "start condition", "address", "data", and "stop condition" output via the I<sup>2</sup>C bus's serial data bus.

**Figure 13-14. I<sup>2</sup>C Bus Serial Data Transfer Timing**



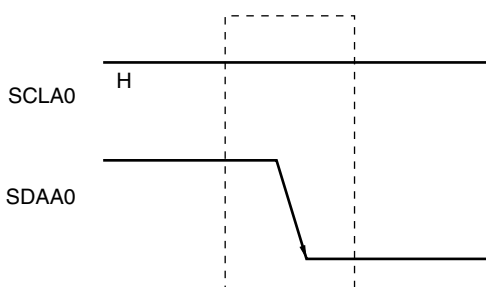
The master device generates the start condition, slave address, and stop condition. The acknowledge ( $\overline{\text{ACK}}$ ) can be generated by either the master or slave device (normally, it is output by the device that receives 8-bit data).

The serial clock (SCLA0) is continuously output by the master device. However, in the slave device, the SCLA0 pin low level period can be extended and a wait can be inserted.

#### 13.5.1 Start conditions

A start condition is met when the SCLA0 pin is at high level and the SDAA0 pin changes from high level to low level. The start conditions for the SCLA0 pin and SDAA0 pin are signals that the master device generates to the slave device when starting a serial transfer. When the device is used as a slave, start conditions can be detected.

**Figure 13-15. Start Conditions**



A start condition is output when bit 1 (STT0) of IICA control register 00 (IICCTL00) is set (1) after a stop condition has been detected (SPD0: Bit 0 of the IICA status register 0 (IICCS0) = 1). When a start condition is detected, bit 1 (STD0) of the IICCS0 register is set (1).

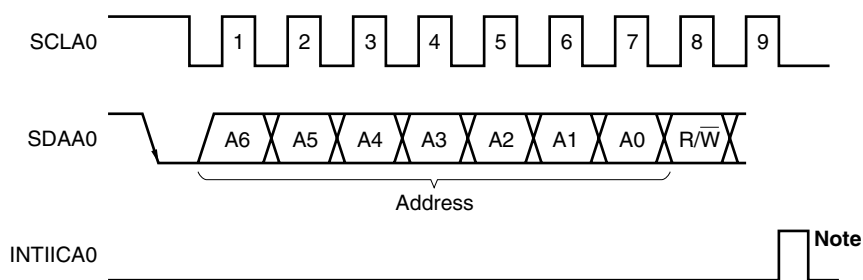
### 13.5.2 Addresses

The address is defined by the 7 bits of data that follow the start condition.

An address is a 7-bit data segment that is output in order to select one of the slave devices that are connected to the master device via the bus lines. Therefore, each slave device connected via the bus lines must have a unique address.

The slave devices include hardware that detects the start condition and checks whether or not the 7-bit address data matches the data values stored in the slave address register 0 (SVA0). If the address data matches the SVA0 register values, the slave device is selected and communicates with the master device until the master device generates a start condition or stop condition.

Figure 13-16. Address



**Note** INTIICA0 is not issued if data other than a local address or extension code is received during slave device operation.

Addresses are output when a total of 8 bits consisting of the slave address and the transfer direction described in **13.5.3 Transfer direction specification** are written to the IICA shift register 0 (IICA0). The received addresses are written to the IICA0 register.

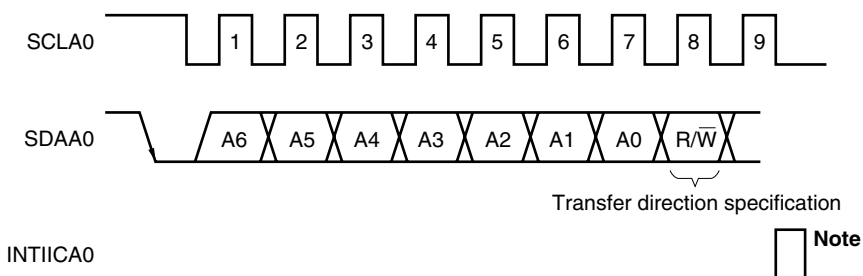
The slave address is assigned to the higher 7 bits of the IICA0 register.

### 13.5.3 Transfer direction specification

In addition to the 7-bit address data, the master device sends 1 bit that specifies the transfer direction.

When this transfer direction specification bit has a value of “0”, it indicates that the master device is transmitting data to a slave device. When the transfer direction specification bit has a value of “1”, it indicates that the master device is receiving data from a slave device.

Figure 13-17. Transfer Direction Specification



**Note** INTIICA0 is not issued if data other than a local address or extension code is received during slave device operation.

### 13.5.4 Acknowledge ( $\overline{\text{ACK}}$ )

$\overline{\text{ACK}}$  is used to check the status of serial data at the transmission and reception sides.

The reception side returns  $\overline{\text{ACK}}$  each time it has received 8-bit data.

The transmission side usually receives  $\overline{\text{ACK}}$  after transmitting 8-bit data. When  $\overline{\text{ACK}}$  is returned from the reception side, it is assumed that reception has been correctly performed and processing is continued. Whether  $\overline{\text{ACK}}$  has been detected can be checked by using bit 2 (ACKD0) of the IICA status register 0 (IICS0).

When the master receives the last data item, it does not return  $\overline{\text{ACK}}$  and instead generates a stop condition. If a slave does not return  $\overline{\text{ACK}}$  after receiving data, the master outputs a stop condition or restart condition and stops transmission. If  $\overline{\text{ACK}}$  is not returned, the possible causes are as follows.

- <1> Reception was not performed normally.
- <2> The final data item was received.
- <3> The reception side specified by the address does not exist.

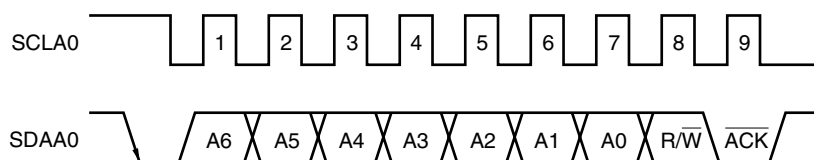
To generate  $\overline{\text{ACK}}$ , the reception side makes the SDAA0 line low at the ninth clock (indicating normal reception).

Automatic generation of  $\overline{\text{ACK}}$  is enabled by setting bit 2 (ACKE0) of IICA control register 00 (IICCTL00) to 1. Bit 3 (TRC0) of the IICS0 register is set by the data of the eighth bit that follows 7-bit address information. Usually, set the ACKE0 bit to 1 for reception (TRC0 = 0).

If a slave can receive no more data during reception (TRC0 = 0) or does not require the next data item, then the slave must inform the master, by clearing the ACKE0 bit to 0, that it will not receive any more data.

When the master does not require the next data item during reception (TRC0 = 0), it must clear the ACKE0 bit to 0 so that  $\overline{\text{ACK}}$  is not generated. In this way, the master informs a slave at the transmission side that it does not require any more data (transmission will be stopped).

Figure 13-18.  $\overline{\text{ACK}}$



When the local address is received,  $\overline{\text{ACK}}$  is automatically generated, regardless of the value of the ACKE0 bit. When an address other than that of the local address is received,  $\overline{\text{ACK}}$  is not generated (NACK).

When an extension code is received,  $\overline{\text{ACK}}$  is generated if the ACKE0 bit is set to 1 in advance.

How  $\overline{\text{ACK}}$  is generated when data is received differs as follows depending on the setting of the wait timing.

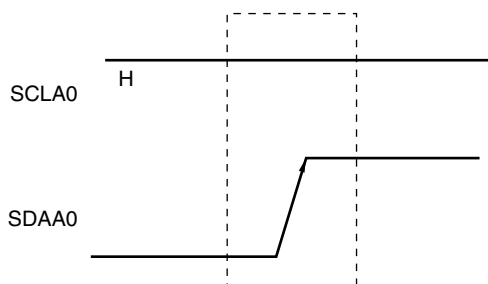
- When 8-clock wait state is selected (bit 3 (WTIM0) of IICCTL00 register = 0):  
By setting the ACKE0 bit to 1 before releasing the wait state,  $\overline{\text{ACK}}$  is generated at the falling edge of the eighth clock of the SCLA0 pin.
- When 9-clock wait state is selected (bit 3 (WTIM0) of IICCTL00 register = 1):  
 $\overline{\text{ACK}}$  is generated by setting the ACKE0 bit to 1 in advance.

### 13.5.5 Stop condition

When the SCLA0 pin is at high level, changing the SDAA0 pin from low level to high level generates a stop condition.

A stop condition is a signal that the master device generates to the slave device when serial transfer has been completed. When the device is used as a slave, stop conditions can be detected.

**Figure 13-19. Stop Condition**



A stop condition is generated when bit 0 (SPT0) of IICA control register 00 (IICCTL00) is set to 1. When the stop condition is detected, bit 0 (SPD0) of the IICA status register 0 (IICS0) is set to 1 and INTIICA0 is generated when bit 4 (SPIE0) of the IICCTL00 register is set to 1.



**13.5.6 Wait**

The wait is used to notify the communication partner that a device (master or slave) is preparing to transmit or receive data (i.e., is in a wait state).

Setting the SCLA0 pin to low level notifies the communication partner of the wait state. When wait state has been canceled for both the master and slave devices, the next data transfer can begin.

**Figure 13-20. Wait (1/2)**

**(1) When master device has a nine-clock wait and slave device has an eight-clock wait (master transmits, slave receives, and ACKE0 = 1)**

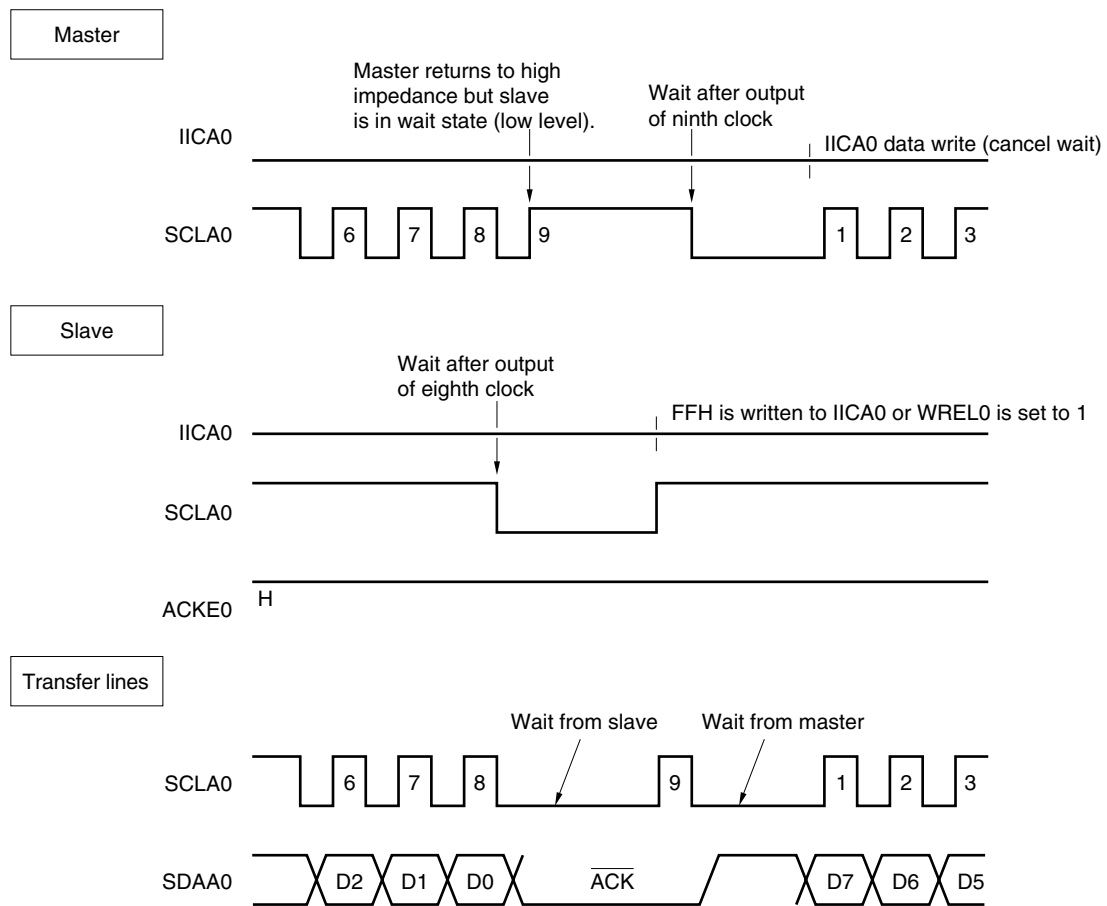
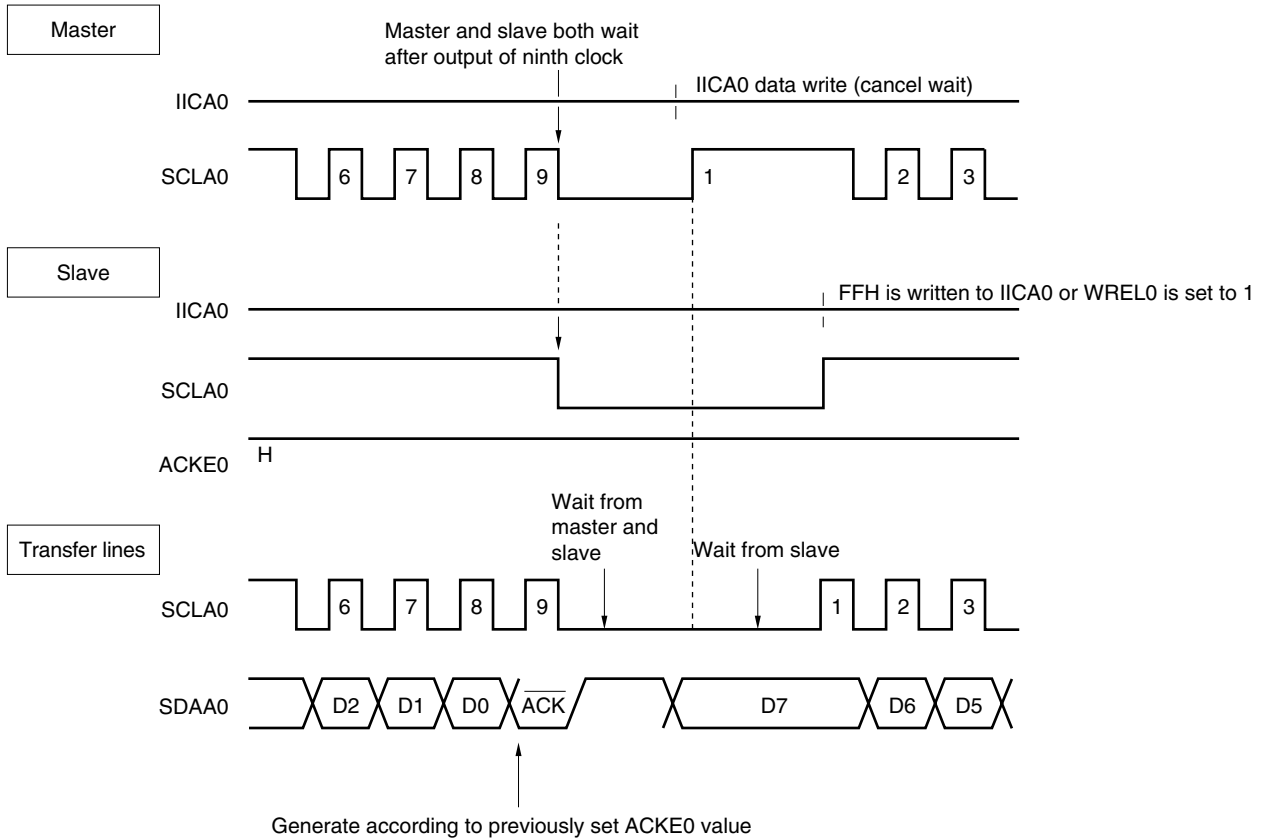


Figure 13-20. Wait (2/2)

**(2) When master and slave devices both have a nine-clock wait (master transmits, slave receives, and ACKE0 = 1)**



**Remark** ACKE0: Bit 2 of IICA control register 00 (IICCTL00)  
 WREL0: Bit 5 of IICA control register 00 (IICCTL00)

A wait may be automatically generated depending on the setting of bit 3 (WTIM0) of IICA control register 00 (IICCTL00). Normally, the receiving side cancels the wait state when bit 5 (WREL0) of the IICCTL00 register is set to 1 or when FFH is written to the IICA shift register 0 (IICA0), and the transmitting side cancels the wait state when data is written to the IICA0 register.

The master device can also cancel the wait state via either of the following methods.

- By setting bit 1 (STT0) of the IICCTL00 register to 1
- By setting bit 0 (SPT0) of the IICCTL00 register to 1

### 13.5.7 Canceling wait

The I<sup>2</sup>C usually cancels a wait state by the following processing.

- Writing data to the IICA shift register 0 (IICA0)
- Setting bit 5 (WRELO) of IICA control register 00 (IICCTL00) (canceling wait)
- Setting bit 1 (STT0) of the IICCTL00 register (generating start condition)<sup>Note</sup>
- Setting bit 0 (SPT0) of the IICCTL00 register (generating stop condition)<sup>Note</sup>

**Note** Master only

When the above wait canceling processing is executed, the I<sup>2</sup>C cancels the wait state and communication is resumed.

To cancel a wait state and transmit data (including addresses), write the data to the IICA0 register.

To receive data after canceling a wait state, or to complete data transmission, set bit 5 (WRELO) of the IICCTL00 register to 1.

To generate a restart condition after canceling a wait state, set bit 1 (STT0) of the IICCTL00 register to 1.

To generate a stop condition after canceling a wait state, set bit 0 (SPT0) of the IICCTL00 register to 1.

Execute the canceling processing only once for one wait state.

If, for example, data is written to the IICA0 register after canceling a wait state by setting the WRELO bit to 1, an incorrect value may be output to SDA0 line because the timing for changing the SDA0 line conflicts with the timing for writing the IICA0 register.

In addition to the above, communication is stopped if the IICE0 bit is cleared to 0 when communication has been aborted, so that the wait state can be canceled.

If the I<sup>2</sup>C bus has deadlocked due to noise, processing is saved from communication by setting bit 6 (LRELO) of the IICCTL00 register, so that the wait state can be canceled.

**Caution** If a processing to cancel a wait state is executed when WUP0 = 1, the wait state will not be canceled.

### 13.5.8 Interrupt request (INTIICA0) generation timing and wait control

The setting of bit 3 (WTIM0) of IICA control register 00 (IICCTL00) determines the timing by which INTIICA0 is generated and the corresponding wait control, as shown in Table 13-2.

**Table 13-2. INTIICA0 Generation Timing and Wait Control**

WTIM0	During Slave Device Operation			During Master Device Operation		
	Address	Data Reception	Data Transmission	Address	Data Reception	Data Transmission
0	9 <sup>Notes 1, 2</sup>	8 <sup>Note 2</sup>	8 <sup>Note 2</sup>	9	8	8
1	9 <sup>Notes 1, 2</sup>	9 <sup>Note 2</sup>	9 <sup>Note 2</sup>	9	9	9

**Notes 1.** The slave device's INTIICA0 signal and wait period occurs at the falling edge of the ninth clock only when there is a match with the address set to the slave address register 0 (SVA0).

At this point,  $\overline{ACK}$  is generated regardless of the value set to the IICCTL00 register's bit 2 (ACKE0). For a slave device that has received an extension code, INTIICA0 occurs at the falling edge of the eighth clock.

However, if the address does not match after restart, INTIICA0 is generated at the falling edge of the 9th clock, but wait does not occur.

- 2.** If the received address does not match the contents of the slave address register 0 (SVA0) and extension code is not received, neither INTIICA0 nor a wait occurs.

**Remark** The numbers in the table indicate the number of the serial clock's clock signals. Interrupt requests and wait control are both synchronized with the falling edge of these clock signals.

#### (1) During address transmission/reception

- Slave device operation: Interrupt and wait timing are determined depending on the conditions described in Notes 1 and 2 above, regardless of the WTIM0 bit.
- Master device operation: Interrupt and wait timing occur at the falling edge of the ninth clock regardless of the WTIM0 bit.

#### (2) During data reception

- Master/slave device operation: Interrupt and wait timing are determined according to the WTIM0 bit.

#### (3) During data transmission

- Master/slave device operation: Interrupt and wait timing are determined according to the WTIM0 bit.

#### (4) Wait cancellation method

The four wait cancellation methods are as follows.

- Writing data to the IICA shift register 0 (IICA0)
- Setting bit 5 (WRELO) of IICA control register 00 (IICCTL00) (canceling wait)
- Setting bit 1 (STT0) of IICCTL00 register (generating start condition)<sup>Note</sup>
- Setting bit 0 (SPT0) of IICCTL00 register (generating stop condition)<sup>Note</sup>

**Note** Master only.

When an 8-clock wait has been selected (WTIM0 = 0), the presence/absence of  $\overline{ACK}$  generation must be determined prior to wait cancellation.

#### (5) Stop condition detection

INTIICA0 is generated when a stop condition is detected (only when SPIE0 = 1).

### 13.5.9 Address match detection method

In I<sup>2</sup>C bus mode, the master device can select a particular slave device by transmitting the corresponding slave address.

Address match can be detected automatically by hardware. An interrupt request (INTIICA0) occurs when the address set to the slave address register 0 (SVA0) matches the slave address sent by the master device, or when an extension code has been received.

### 13.5.10 Error detection

In I<sup>2</sup>C bus mode, the status of the serial data bus (SDAA0) during data transmission is captured by the IICA shift register 0 (IICA0) of the transmitting device, so the IICA data prior to transmission can be compared with the transmitted IICA data to enable detection of transmission errors. A transmission error is judged as having occurred when the compared data values do not match.

### 13.5.11 Extension code

- (1) When the higher 4 bits of the receive address are either "0000" or "1111", the extension code reception flag (EXC0) is set to 1 for extension code reception and an interrupt request (INTIICA0) is issued at the falling edge of the eighth clock. The local address stored in the slave address register 0 (SVA0) is not affected.
- (2) The settings below are specified if 11110xx0 is transferred from the master by using a 10-bit address transfer when the SVA0 register is set to 11110xx0. Note that INTIICA0 occurs at the falling edge of the eighth clock.

- Higher four bits of data match: EXC0 = 1
- Seven bits of data match: COI0 = 1

**Remark** EXC0: Bit 5 of IICA status register 0 (IICS0)  
COI0: Bit 4 of IICA status register 0 (IICS0)

- (3) Since the processing after the interrupt request occurs differs according to the data that follows the extension code, such processing is performed by software.

If the extension code is received while a slave device is operating, then the slave device is participating in communication even if its address does not match.

For example, after the extension code is received, if you do not wish to operate the target device as a slave device, set bit 6 (LREL0) of IICA control register 00 (IICCTL00) to 1 to set the standby mode for the next communication operation.

**Table 13-3. Bit Definitions of Major Extension Codes**

Slave Address	R/W Bit	Description
0 0 0 0 0 0 0	0	General call address
1 1 1 1 0 x x	0	10-bit slave address specification (during address authentication)
1 1 1 1 0 x x	1	10-bit slave address specification (after address match, when read command is issued)

**Remark** See the I<sup>2</sup>C bus specifications issued by NXP Semiconductors for details of extension codes other than those described above.

**13.5.12 Arbitration**

When several master devices simultaneously generate a start condition (when the STT0 bit is set to 1 before the STD0 bit is set to 1), communication among the master devices is performed as the number of clocks are adjusted until the data differs. This kind of operation is called arbitration.

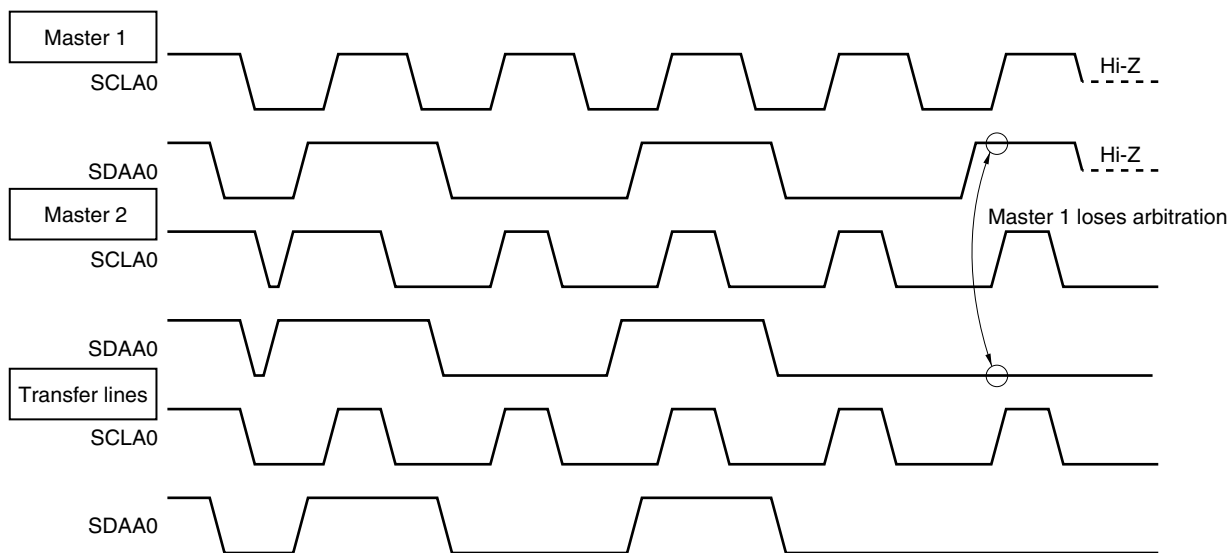
When one of the master devices loses in arbitration, an arbitration loss flag (ALD0) in the IICA status register 0 (IICS0) is set (1) via the timing by which the arbitration loss occurred, and the SCLA0 and SDAA0 lines are both set to high impedance, which releases the bus.

The arbitration loss is detected based on the timing of the next interrupt request (the eighth or ninth clock, when a stop condition is detected, etc.) and the ALD0 = 1 setting that has been made by software.

For details of interrupt request timing, see **13.5.8 Interrupt request (INTIICA0) generation timing and wait control.**

**Remark** STD0: Bit 1 of IICA status register 0 (IICS0)  
 STT0: Bit 1 of IICA control register 00 (IICCTL00)

**Figure 13-21. Arbitration Timing Example**



**Table 13-4. Status During Arbitration and Interrupt Request Generation Timing**

Status During Arbitration	Interrupt Request Generation Timing
During address transmission	At falling edge of eighth or ninth clock following byte transfer <sup>Note 1</sup>
Read/write data after address transmission	
During extension code transmission	
Read/write data after extension code transmission	
During data transmission	
During $\overline{\text{ACK}}$ transfer period after data transmission	
When restart condition is detected during data transfer	
When stop condition is detected during data transfer	When stop condition is generated (when SPIE0 = 1) <sup>Note 2</sup>
When data is at low level while attempting to generate a restart condition	At falling edge of eighth or ninth clock following byte transfer <sup>Note 1</sup>
When stop condition is detected while attempting to generate a restart condition	When stop condition is generated (when SPIE0 = 1) <sup>Note 2</sup>
When data is at low level while attempting to generate a stop condition	At falling edge of eighth or ninth clock following byte transfer <sup>Note 1</sup>
When SCLA0 is at low level while attempting to generate a restart condition	

- Notes 1.** When the WTIM0 bit (bit 3 of IICA control register 00 (IICCTL00)) = 1, an interrupt request occurs at the falling edge of the ninth clock. When WTIM0 = 0 and the extension code's slave address is received, an interrupt request occurs at the falling edge of the eighth clock.
- 2.** When there is a chance that arbitration will occur, set SPIE0 = 1 for master device operation.

**Remark** SPIE0: Bit 4 of IICA control register 00 (IICCTL00)

**13.5.13 Wakeup function**

The I<sup>2</sup>C bus slave function is a function that generates an interrupt request signal (INTIICA0) when a local address and extension code have been received.

This function makes processing more efficient by preventing unnecessary INTIICA0 signal from occurring when addresses do not match.

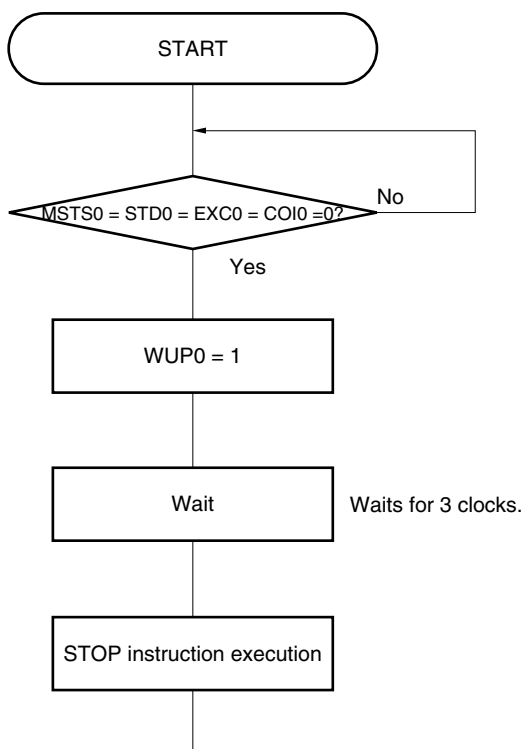
When a start condition is detected, wakeup standby mode is set. This wakeup standby mode is in effect while addresses are transmitted due to the possibility that an arbitration loss may change the master device (which has generated a start condition) to a slave device.

However, when a stop condition is detected, bit 4 (SPIE0) of IICA control register 00 (IICCTL00) is set regardless of the wakeup function, and this determines whether interrupt requests are enabled or disabled.

To use the wakeup function in the STOP mode, set the WUP0 bit to 1. Addresses can be received regardless of the operation clock. An interrupt request signal (INTIICA0) is also generated when a local address and extension code have been received. Operation returns to normal operation by using an instruction to clear (0) the WUP0 bit after this interrupt has been generated.

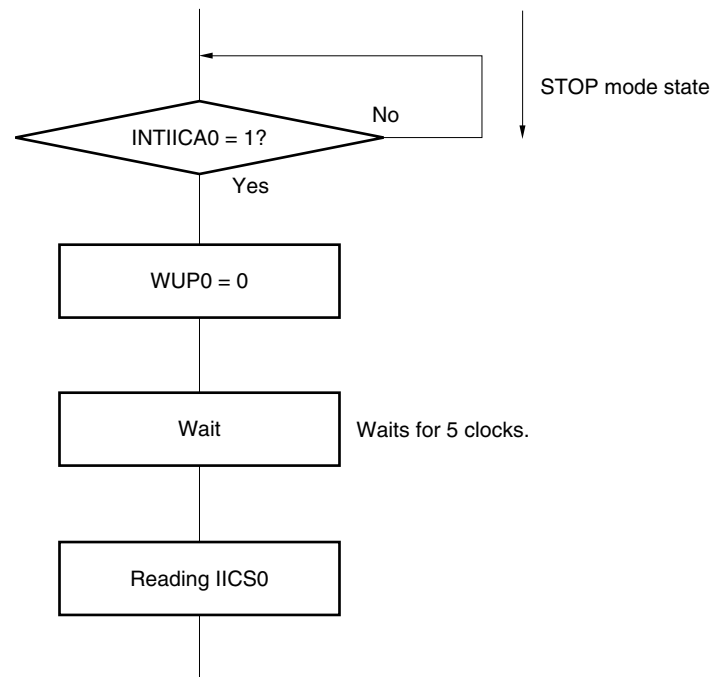
Figure 13-22 shows the flow for setting WUP0 = 1 and Figure 13-23 shows the flow for setting WUP0 = 0 upon an address match.

**Figure 13-22. Flow When Setting WUP0 = 1**





**Figure 13-23. Flow When Setting WUP0 = 0 upon Address Match (Including Extension Code Reception)**

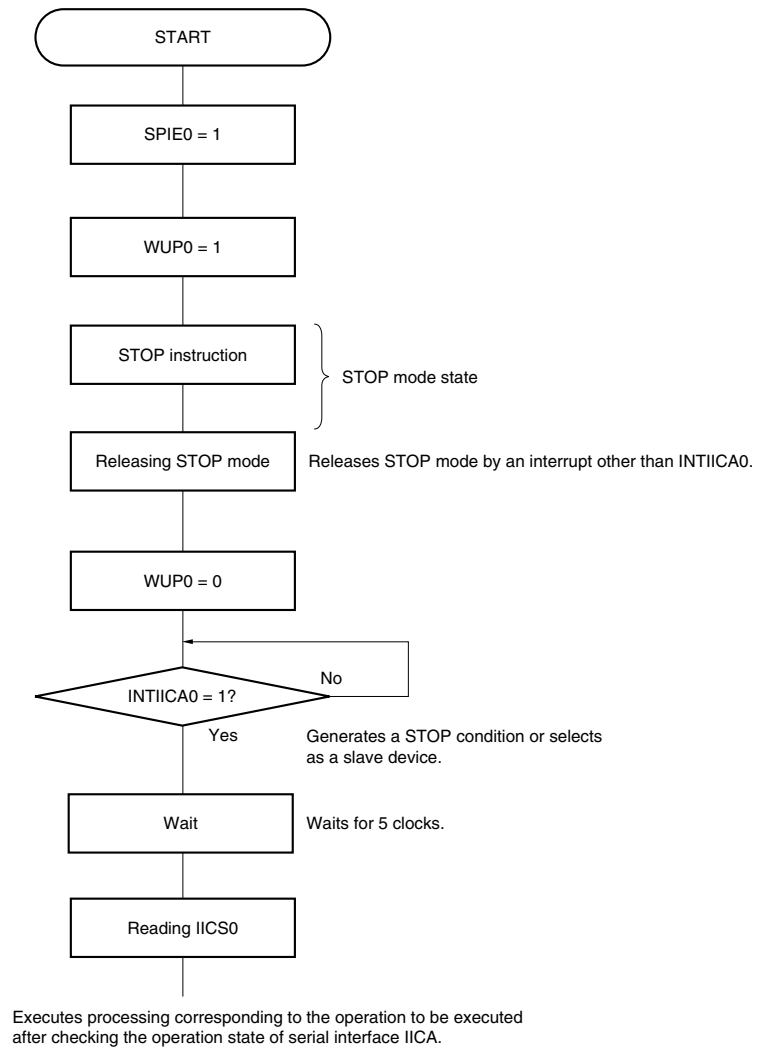


Executes processing corresponding to the operation to be executed after checking the operation state of serial interface IICA.

Use the following flows to perform the processing to release the STOP mode other than by an interrupt request (INTIICA0) generated from serial interface IICA.

- Master device operation: Flow shown in Figure 13-24
- Slave device operation: Same as the flow in Figure 13-23

Figure 13-24. When Operating as Master Device after Releasing STOP Mode other than by INTIICA0



### 13.5.14 Communication reservation

#### (1) When communication reservation function is enabled (bit 0 (IICRSV) of IICA flag register 0 (IICF0) = 0)

To start master device communications when not currently using a bus, a communication reservation can be made to enable transmission of a start condition when the bus is released. There are two modes under which the bus is not used.

- When arbitration results in neither master nor slave operation
- When an extension code is received and slave operation is disabled ( $\overline{ACK}$  is not returned and the bus was released by setting bit 6 (LRELO) of IICA control register 00 (IICCTL00) to 1 and saving communication).

If bit 1 (STT0) of the IICCTL00 register is set to 1 while the bus is not used (after a stop condition is detected), a start condition is automatically generated and wait state is set.

If an address is written to the IICA shift register 0 (IICA0) after bit 4 (SPIE0) of the IICCTL00 register was set to 1, and it was detected by generation of an interrupt request signal (INTIICA0) that the bus was released (detection of the stop condition), then the device automatically starts communication as the master. Data written to the IICA0 register before the stop condition is detected is invalid.

When the STT0 bit has been set to 1, the operation mode (as start condition or as communication reservation) is determined according to the bus status.

- If the bus has been released ..... a start condition is generated
- If the bus has not been released (standby mode)..... communication reservation

Check whether the communication reservation operates or not by using the MSTSO bit (bit 7 of the IICA status register 0 (IICS0)) after the STT0 bit is set to 1 and the wait time elapses.

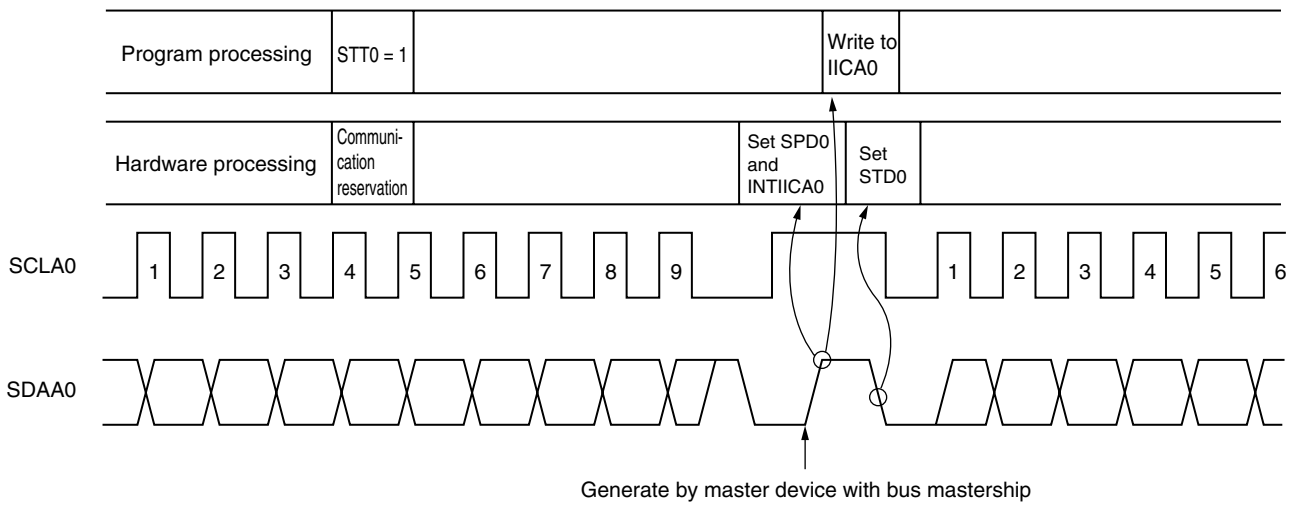
Use software to secure the wait time calculated by the following expression.

Wait time from setting STT0 = 1 to checking the MSTSO flag:  
 $(IICWLO \text{ setting value} + IICWH0 \text{ setting value} + 4) + t_F \times 2 \times f_{CLK} \text{ [clocks]}$

**Remark** IICWLO: IICA low-level width setting register 0  
 IICWH0: IICA high-level width setting register 0  
 $t_F$ : SDAA0 and SCLA0 signal falling times  
 $f_{CLK}$ : CPU/peripheral hardware clock frequency

Figure 13-25 shows the communication reservation timing.

**Figure 13-25. Communication Reservation Timing**



- Remark** IICA0: IICA shift register 0  
 STT0: Bit 1 of IICA control register 00 (IICCTL00)  
 STD0: Bit 1 of IICA status register 0 (IICS0)  
 SPD0: Bit 0 of IICA status register 0 (IICS0)

Communication reservations are accepted via the timing shown in Figure 13-26. After bit 1 (STD0) of the IICA status register 0 (IICS0) is set to 1, a communication reservation can be made by setting bit 1 (STT0) of IICA control register 00 (IICCTL00) to 1 before a stop condition is detected.

**Figure 13-26. Timing for Accepting Communication Reservations**

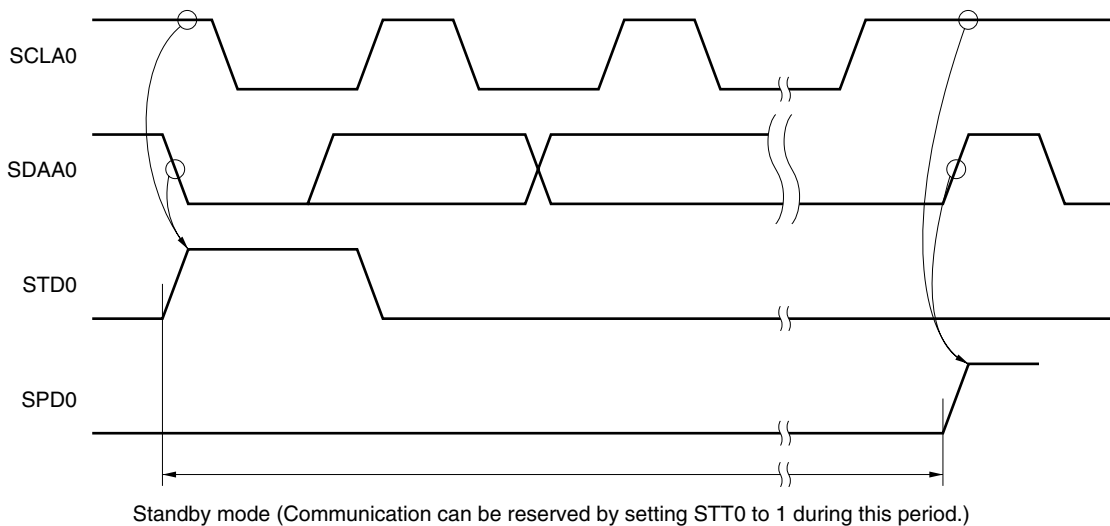
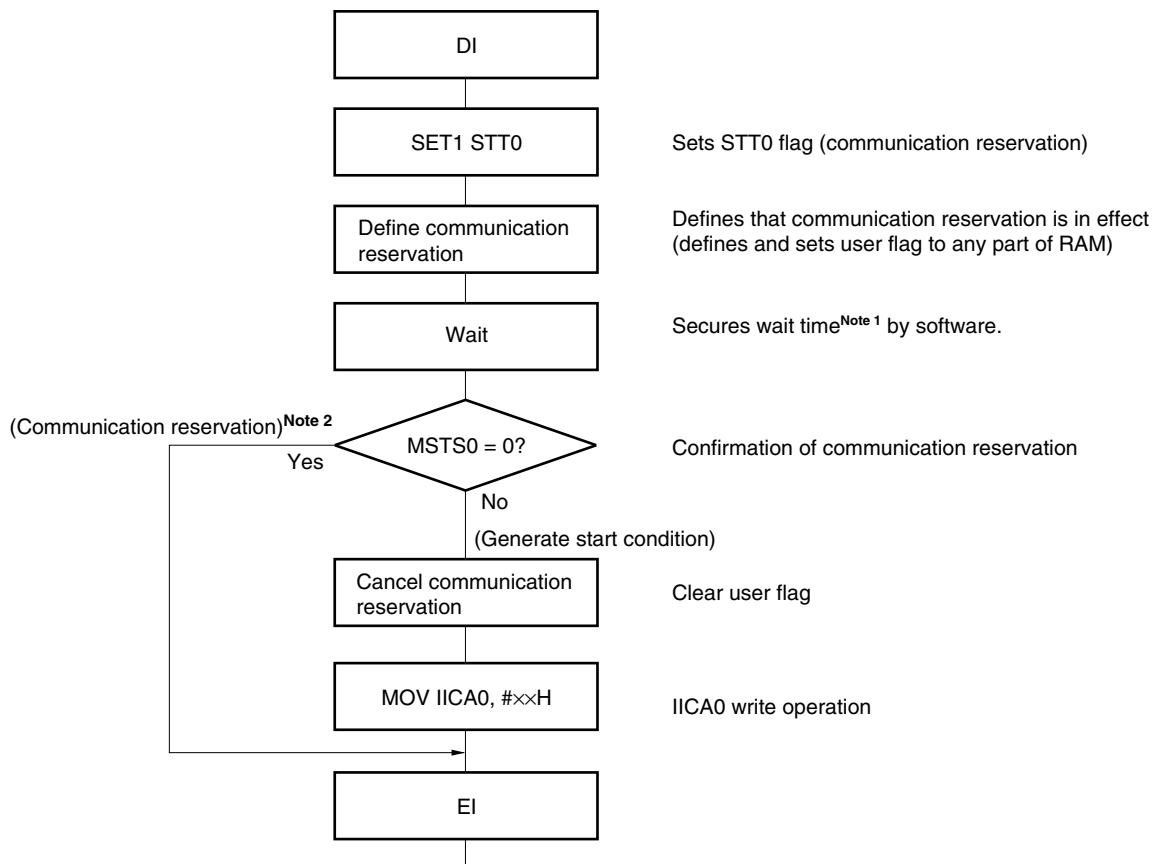


Figure 13-27 shows the communication reservation protocol.

Figure 13-27. Communication Reservation Protocol



**Notes 1.** The wait time is calculated as follows.

$$(\text{IICWL0 setting value} + \text{IICWH0 setting value} + 4) + t_F \times 2 \times f_{\text{CLK}} [\text{clocks}]$$

- 2.** The communication reservation operation executes a write to the IICA shift register 0 (IICA0) when a stop condition interrupt request occurs.

**Remark** STT0: Bit 1 of IICA control register 00 (IICCTL00)

MSTS0: Bit 7 of IICA status register 0 (IICS0)

IICA0: IICA shift register 0

IICWL0: IICA low-level width setting register 0

IICWH0: IICA high-level width setting register 0

$t_F$ : SDA0 and SCLA0 signal falling times

$f_{\text{CLK}}$ : CPU/peripheral hardware clock frequency

**(2) When communication reservation function is disabled (bit 0 (IICRSV) of IICA flag register 0 (IICF0) = 1)**

When bit 1 (STT0) of IICA control register 00 (IICCTL00) is set to 1 when the bus is not used in a communication during bus communication, this request is rejected and a start condition is not generated. The following two statuses are included in the status where bus is not used.

- When arbitration results in neither master nor slave operation
- When an extension code is received and slave operation is disabled ( $\overline{ACK}$  is not returned and the bus was released by setting bit 6 (LREL0) of the IICCTL00 register to 1 and saving communication)

To confirm whether the start condition was generated or request was rejected, check STCF (bit 7 of the IICF0 register). It takes up to 5 clocks until the STCF bit is set to 1 after setting STT0 = 1. Therefore, secure the time by software.

### 13.5.15 Cautions

(1) When STCEN = 0

Immediately after I<sup>2</sup>C operation is enabled (IICE0 = 1), the bus communication status (IICBSY = 1) is recognized regardless of the actual bus status. When changing from a mode in which no stop condition has been detected to a master device communication mode, first generate a stop condition to release the bus, then perform master device communication.

When using multiple masters, it is not possible to perform master device communication when the bus has not been released (when a stop condition has not been detected).

Use the following sequence for generating a stop condition.

- <1> Set IICA control register 01 (IICCTL01).
- <2> Set bit 7 (IICE0) of IICA control register 00 (IICCTL00) to 1.
- <3> Set bit 0 (SPT0) of the IICCTL00 register to 1.

(2) When STCEN = 1

Immediately after I<sup>2</sup>C operation is enabled (IICE0 = 1), the bus released status (IICBSY = 0) is recognized regardless of the actual bus status. To generate the first start condition (STT0 = 1), it is necessary to confirm that the bus has been released, so as to not disturb other communications.

(3) If other I<sup>2</sup>C communications are already in progress

If I<sup>2</sup>C operation is enabled and the device participates in communication already in progress when the SDAA0 pin is low and the SCLA0 pin is high, the macro of I<sup>2</sup>C recognizes that the SDAA0 pin has gone low (detects a start condition). If the value on the bus at this time can be recognized as an extension code,  $\overline{ACK}$  is returned, but this interferes with other I<sup>2</sup>C communications. To avoid this, start I<sup>2</sup>C in the following sequence.

- <1> Clear bit 4 (SPIE0) of the IICCTL00 register to 0 to disable generation of an interrupt request signal (INTIICA0) when the stop condition is detected.
- <2> Set bit 7 (IICE0) of the IICCTL00 register to 1 to enable the operation of I<sup>2</sup>C.
- <3> Wait for detection of the start condition.
- <4> Set bit 6 (LREL0) of the IICCTL00 register to 1 before  $\overline{ACK}$  is returned (4 to 80 clocks after setting the IICE0 bit to 1), to forcibly disable detection.

(4) Setting the STT0 and SPT0 bits (bits 1 and 0 of the IICCTL00 register) again after they are set and before they are cleared to 0 is prohibited.

(5) When transmission is reserved, set the SPIE0 bit (bit 4 of the IICCTL0 register) to 1 so that an interrupt request is generated when the stop condition is detected. Transfer is started when communication data is written to the IICA shift register 0 (IICA0) after the interrupt request is generated. Unless the interrupt is generated when the stop condition is detected, the device stops in the wait state because the interrupt request is not generated when communication is started. However, it is not necessary to set the SPIE0 bit to 1 when the MSTS0 bit (bit 7 of the IICA status register 0 (IICS0)) is detected by software.

### 13.5.16 Communication operations

The following shows three operation procedures with the flowchart.

#### (1) Master operation in single master system

The flowchart when using the RL78/G13 as the master in a single master system is shown below.

This flowchart is broadly divided into the initial settings and communication processing. Execute the initial settings at startup. If communication with the slave is required, prepare the communication and then execute communication processing.

#### (2) Master operation in multimaster system

In the I<sup>2</sup>C bus multimaster system, whether the bus is released or used cannot be judged by the I<sup>2</sup>C bus specifications when the bus takes part in a communication. Here, when data and clock are at a high level for a certain period (1 frame), the RL78/G13 takes part in a communication with bus released state.

This flowchart is broadly divided into the initial settings, communication waiting, and communication processing. The processing when the RL78/G13 loses in arbitration and is specified as the slave is omitted here, and only the processing as the master is shown. Execute the initial settings at startup to take part in a communication. Then, wait for the communication request as the master or wait for the specification as the slave. The actual communication is performed in the communication processing, and it supports the transmission/reception with the slave and the arbitration with other masters.

#### (3) Slave operation

An example of when the RL78/G13 is used as the I<sup>2</sup>C bus slave is shown below.

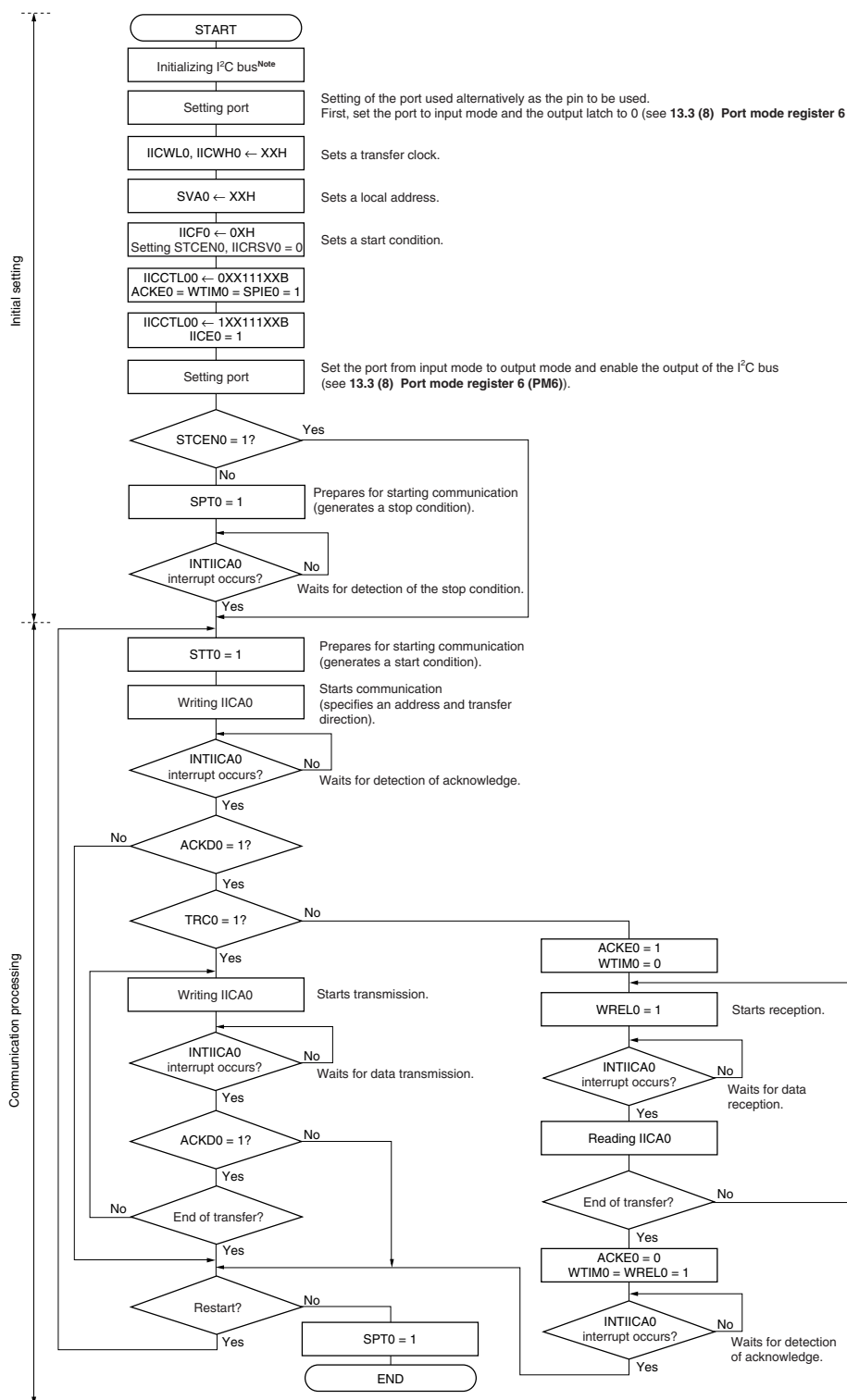
When used as the slave, operation is started by an interrupt. Execute the initial settings at startup, then wait for the INTIICA0 interrupt occurrence (communication waiting). When an INTIICA0 interrupt occurs, the communication status is judged and its result is passed as a flag over to the main processing.

By checking the flags, necessary communication processing is performed.



(1) Master operation in single-master system

Figure 13-28. Master Operation in Single-Master System

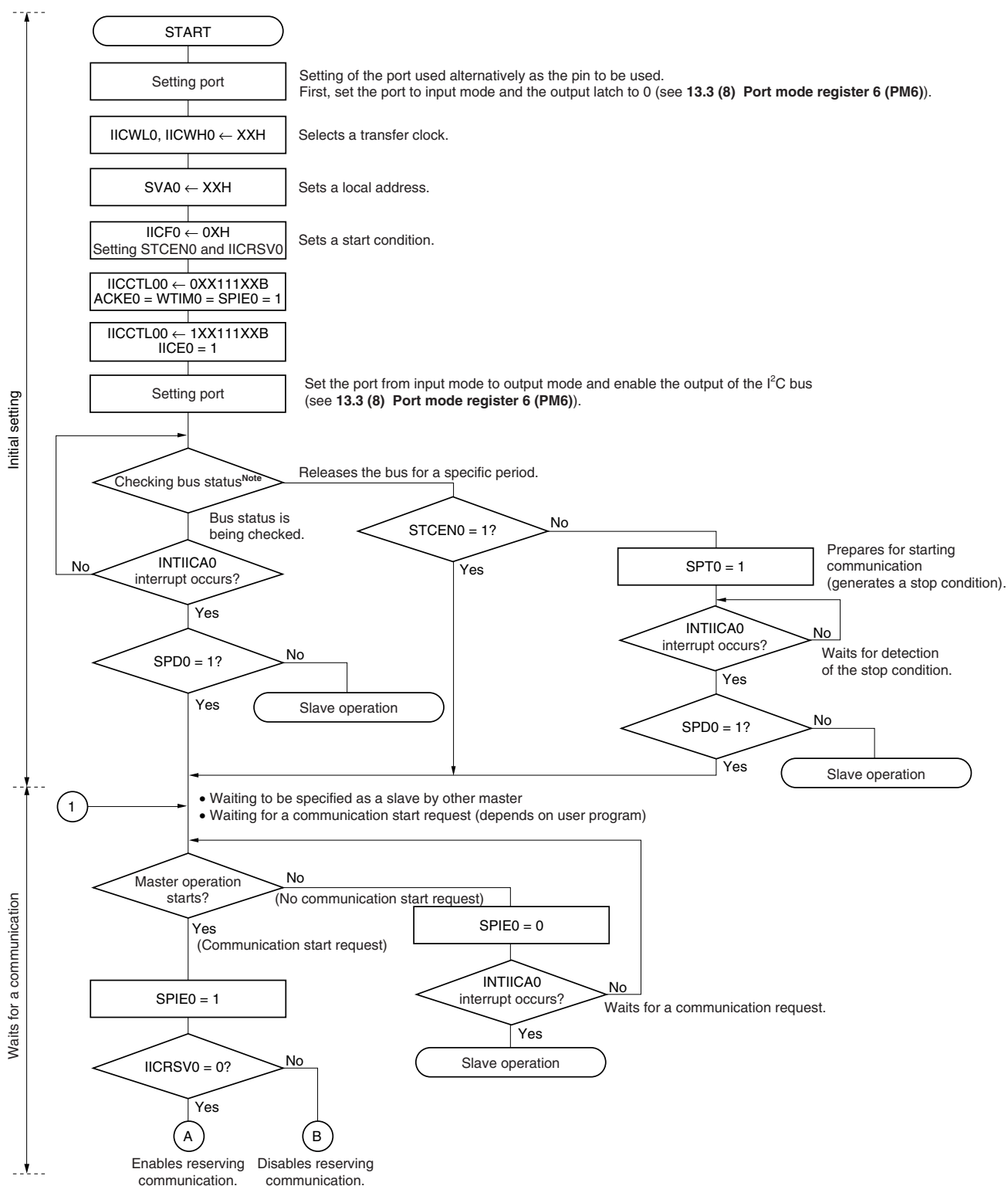


**Note** Release (SCLA0 and SDAA0 pins = high level) the I<sup>2</sup>C bus in conformance with the specifications of the product that is communicating. If EEPROM is outputting a low level to the SDAA0 pin, for example, set the SCLA0 pin in the output port mode, and output a clock pulse from the output port until the SDAA0 pin is constantly at high level.

**Remark** Conform to the specifications of the product that is communicating, with respect to the transmission and reception formats.

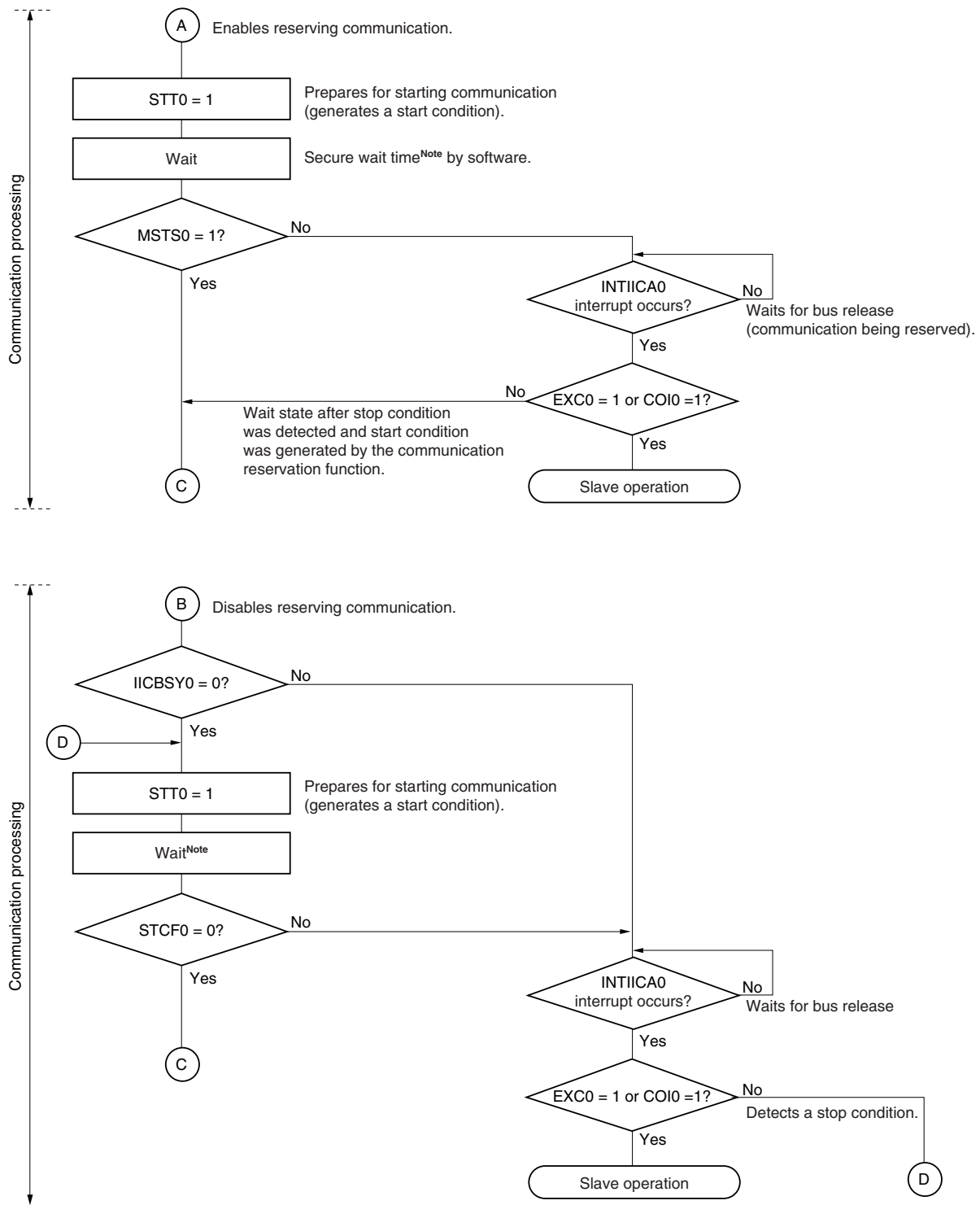
(2) Master operation in multi-master system

Figure 13-29. Master Operation in Multi-Master System (1/3)



**Note** Confirm that the bus is released (CLD0 bit = 1, DAD0 bit = 1) for a specific period (for example, for a period of one frame). If the SDA0 pin is constantly at low level, decide whether to release the I<sup>2</sup>C bus (SCLA0 and SDA0 pins = high level) in conformance with the specifications of the product that is communicating.

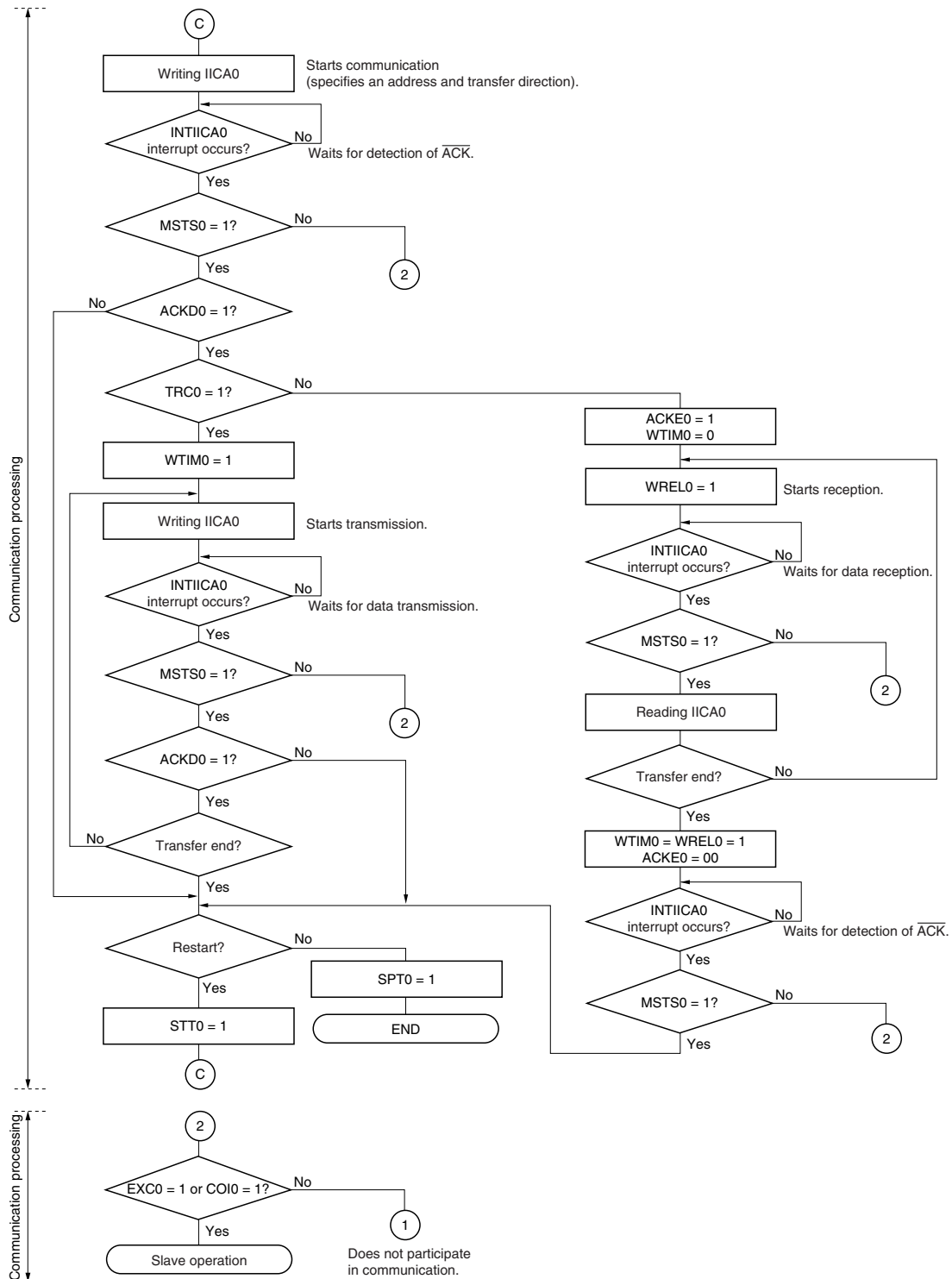
Figure 13-29. Master Operation in Multi-Master System (2/3)



**Note** The wait time is calculated as follows.  
 $(IICWL0 \text{ setting value} + IICWH0 \text{ setting value} + 4) \times f_{CLK} + t_F \times 2$  [clocks]

**Remark** IICWL0: IICA low-level width setting register 0  
 IICWH0: IICA high-level width setting register 0  
 t<sub>F</sub>: SDAA0 and SCLA0 signal falling times  
 f<sub>CLK</sub>: CPU/peripheral hardware clock frequency

Figure 13-29. Master Operation in Multi-Master System (3/3)



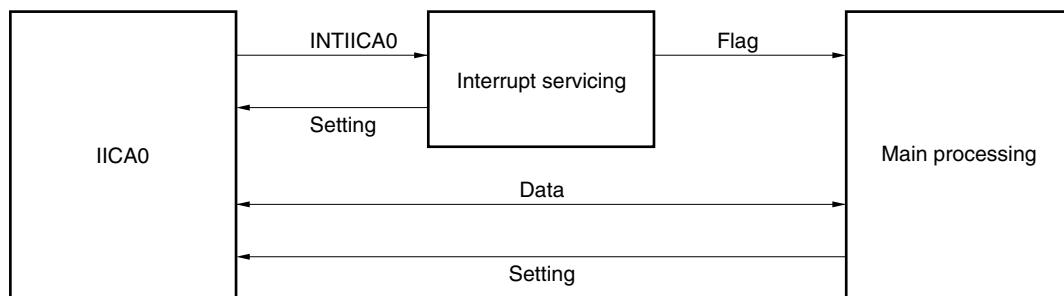
- Remarks**
1. Conform to the specifications of the product that is communicating, with respect to the transmission and reception formats.
  2. To use the device as a master in a multi-master system, read the MSTS0 bit each time interrupt INTIICA0 has occurred to check the arbitration result.
  3. To use the device as a slave in a multi-master system, check the status by using the IICA status register 0 (IICS0) and IICA flag register 0 (IICF0) each time interrupt INTIICA0 has occurred, and determine the processing to be performed next.

**(3) Slave operation**

The processing procedure of the slave operation is as follows.

Basically, the slave operation is event-driven. Therefore, processing by the INTIICA0 interrupt (processing that must substantially change the operation status such as detection of a stop condition during communication) is necessary.

In the following explanation, it is assumed that the extension code is not supported for data communication. It is also assumed that the INTIICA0 interrupt servicing only performs status transition processing, and that actual data communication is performed by the main processing.



Therefore, data communication processing is performed by preparing the following three flags and passing them to the main processing instead of INTIICA0.

**<1> Communication mode flag**

This flag indicates the following two communication statuses.

- Clear mode: Status in which data communication is not performed
- Communication mode: Status in which data communication is performed (from valid address detection to stop condition detection, no detection of  $\overline{\text{ACK}}$  from master, address mismatch)

**<2> Ready flag**

This flag indicates that data communication is enabled. Its function is the same as the INTIICA0 interrupt for ordinary data communication. This flag is set by interrupt servicing and cleared by the main processing. Clear this flag by interrupt servicing when communication is started. However, the ready flag is not set by interrupt servicing when the first data is transmitted. Therefore, the first data is transmitted without the flag being cleared (an address match is interpreted as a request for the next data).

**<3> Communication direction flag**

This flag indicates the direction of communication. Its value is the same as the TRC0 bit.

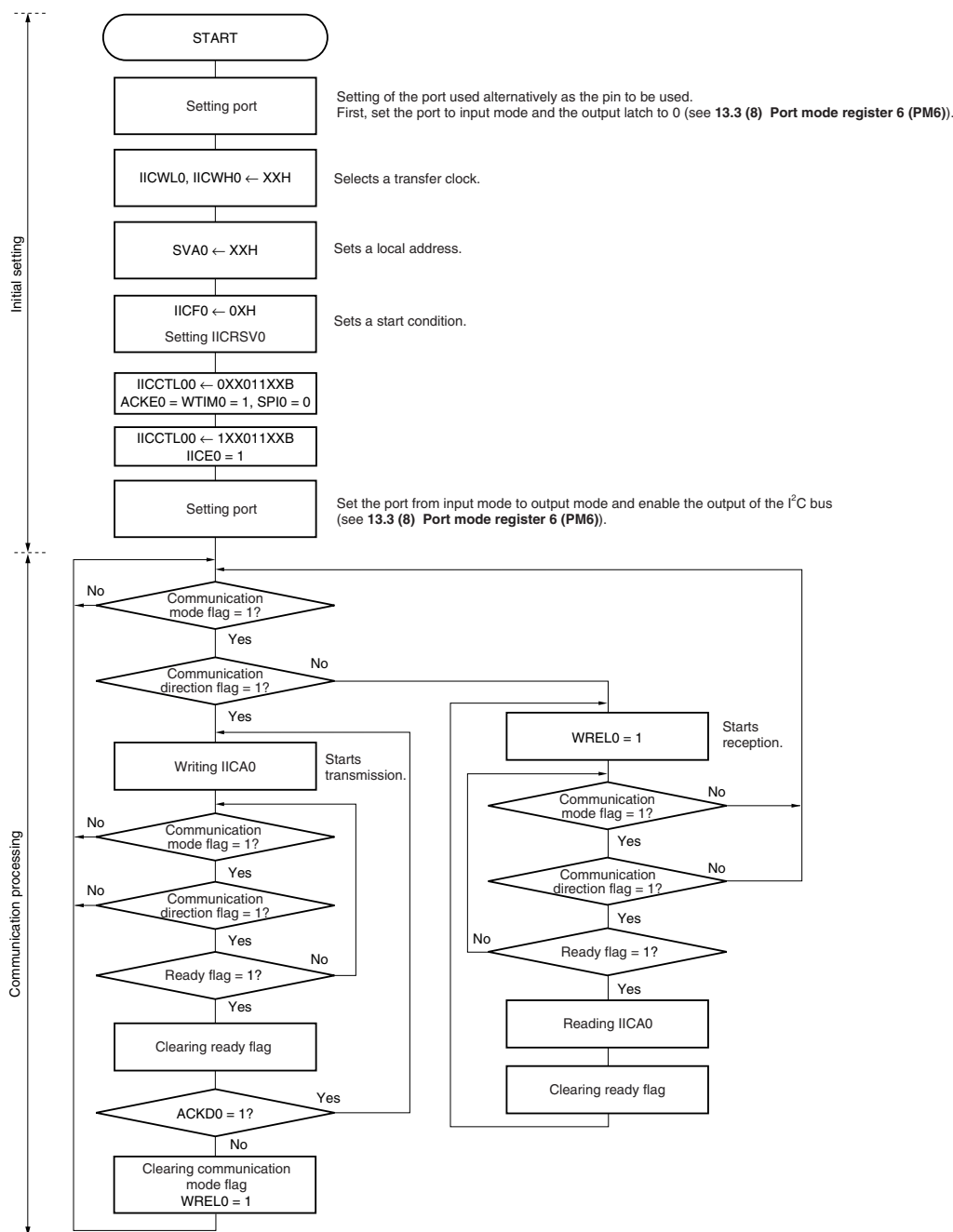
The main processing of the slave operation is explained next.

Start serial interface IICA and wait until communication is enabled. When communication is enabled, execute communication by using the communication mode flag and ready flag (processing of the stop condition and start condition is performed by an interrupt. Here, check the status by using the flags).

The transmission operation is repeated until the master no longer returns  $\overline{ACK}$ . If  $\overline{ACK}$  is not returned from the master, communication is completed.

For reception, the necessary amount of data is received. When communication is completed,  $\overline{ACK}$  is not returned as the next data. After that, the master generates a stop condition or restart condition. Exit from the communication status occurs in this way.

Figure 13-30. Slave Operation Flowchart (1)



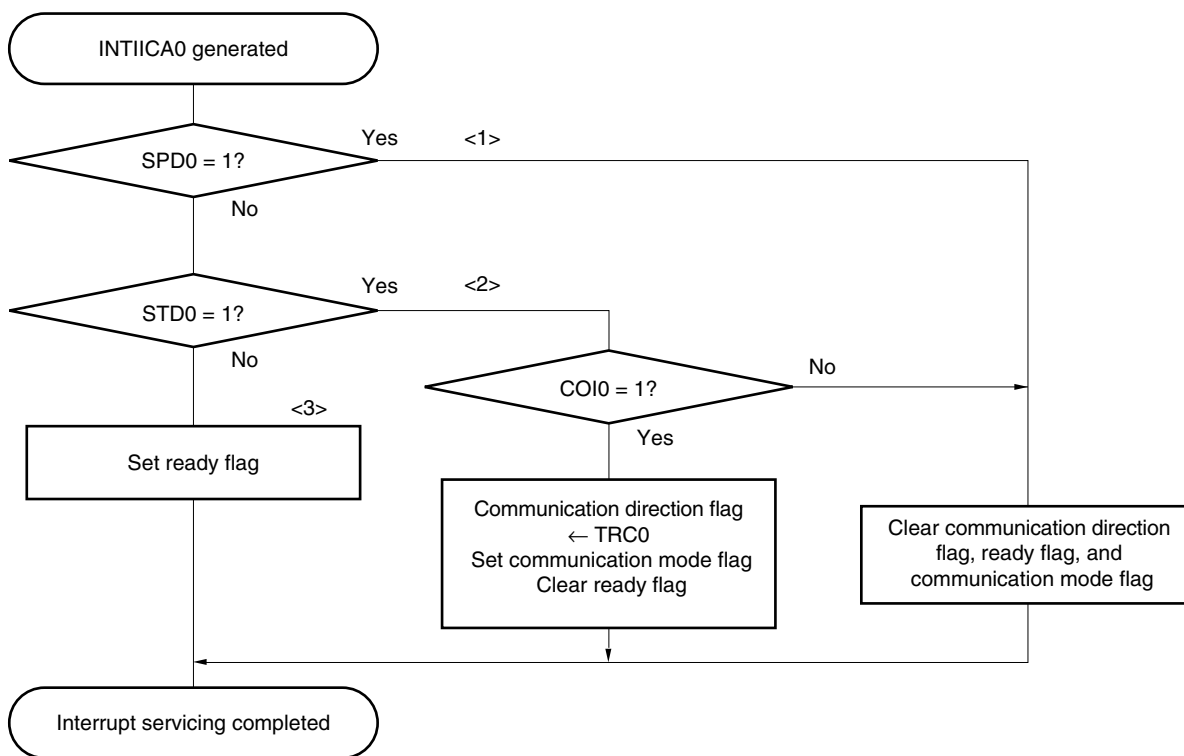
**Remark** Conform to the specifications of the product that is in communication, regarding the transmission and reception formats.

An example of the processing procedure of the slave with the INTIICA0 interrupt is explained below (processing is performed assuming that no extension code is used). The INTIICA0 interrupt checks the status, and the following operations are performed.

- <1> Communication is stopped if the stop condition is issued.
- <2> If the start condition is issued, the address is checked and communication is completed if the address does not match. If the address matches, the communication mode is set, wait is cancelled, and processing returns from the interrupt (the ready flag is cleared).
- <3> For data transmit/receive, only the ready flag is set. Processing returns from the interrupt with the I<sup>2</sup>C bus remaining in the wait state.

**Remark** <1> to <3> above correspond to <1> to <3> in Figure 13-31 Slave Operation Flowchart (2).

**Figure 13-31. Slave Operation Flowchart (2)**



**13.5.17 Timing of I<sup>2</sup>C interrupt request (INTIICA0) occurrence**

The timing of transmitting or receiving data and generation of interrupt request signal INTIICA0, and the value of the IICA status register 0 (IICS0) when the INTIICA0 signal is generated are shown below.

- Remark**
- ST: Start condition
  - AD6 to AD0: Address
  - R/W: Transfer direction specification
  - ACK: Acknowledge
  - D7 to D0: Data
  - SP: Stop condition

(1) Master device operation

(a) Start ~ Address ~ Data ~ Data ~ Stop (transmission/reception)

(i) When WTIM0 = 0

ST	AD6 to AD0	R/W	ACK	D7 to D0	ACK	D7 to D0	ACK	SP
			▲1		▲2		▲3	▲4
							▲3	▲4
								△5

SPT0 = 1  
↓

▲1: IICS0 = 1000×110B  
 ▲2: IICS0 = 1000×000B  
 ▲3: IICS0 = 1000×000B (Sets the WTIM0 bit to 1)<sup>Note</sup>  
 ▲4: IICS0 = 1000××00B (Sets the SPT0 bit to 1)<sup>Note</sup>  
 △5: IICS0 = 00000001B

**Note** To generate a stop condition, set the WTIM0 bit to 1 and change the timing for generating the INTIICA0 interrupt request signal.

**Remark** ▲: Always generated  
 △: Generated only when SPIE0 = 1  
 ×: Don't care

(ii) When WTIM0 = 1

ST	AD6 to AD0	R/W	ACK	D7 to D0	ACK	D7 to D0	ACK	SP
			▲1		▲2		▲3	△4

SPT0 = 1  
↓

▲1: IICS0 = 1000×110B  
 ▲2: IICS0 = 1000×100B  
 ▲3: IICS0 = 1000××00B (Sets the SPT0 bit to 1)  
 △4: IICS0 = 00000001B

**Remark** ▲: Always generated  
 △: Generated only when SPIE0 = 1  
 ×: Don't care



(b) Start ~ Address ~ Data ~ Start ~ Address ~ Data ~ Stop (restart)

(i) When WTIMO = 0

					STT0 = 1						SPT0 = 1		
					↓						↓		
ST	AD6 to AD0	R/W	ACK	D7 to D0	ACK	ST	AD6 to AD0	R/W	ACK	D7 to D0	ACK	SP	
			▲1		▲2	▲3			▲4		▲5	▲6	△7

▲1: IICS0 = 1000×110B  
 ▲2: IICS0 = 1000×000B (Sets the WTIMO bit to 1)<sup>Note 1</sup>  
 ▲3: IICS0 = 1000××00B (Clears the WTIMO bit to 0<sup>Note 2</sup>, sets the STT0 bit to 1)  
 ▲4: IICS0 = 1000×110B  
 ▲5: IICS0 = 1000×000B (Sets the WTIMO bit to 1)<sup>Note 3</sup>  
 ▲6: IICS0 = 1000××00B (Sets the SPT0 bit to 1)  
 △7: IICS0 = 00000001B

**Notes 1.** To generate a start condition, set the WTIMO bit to 1 and change the timing for generating the INTIICA0 interrupt request signal.  
**2.** Clear the WTIMO bit to 0 to restore the original setting.  
**3.** To generate a stop condition, set the WTIMO bit to 1 and change the timing for generating the INTIICA0 interrupt request signal.

**Remark** ▲: Always generated  
 △: Generated only when SPIE0 = 1  
 ×: Don't care

(ii) When WTIMO = 1

					STT0 = 1						SPT0 = 1	
					↓						↓	
ST	AD6 to AD0	R/W	ACK	D7 to D0	ACK	ST	AD6 to AD0	R/W	ACK	D7 to D0	ACK	SP
			▲1		▲2				▲3		▲4	△5

▲1: IICS0 = 1000×110B  
 ▲2: IICS0 = 1000××00B (Sets the STT0 bit to 1)  
 ▲3: IICS0 = 1000×110B  
 ▲4: IICS0 = 1000××00B (Sets the SPT0 bit to 1)  
 △5: IICS0 = 00000001B

**Remark** ▲: Always generated  
 △: Generated only when SPIE0 = 1  
 ×: Don't care

(c) Start ~ Code ~ Data ~ Data ~ Stop (extension code transmission)

(i) When WTIM0 = 0

ST	AD6 to AD0	R $\bar{W}$	ACK	D7 to D0	ACK	D7 to D0	ACK	SP
			▲1		▲2		▲3 ▲4	△5

SPT0 = 1  
↓

▲1: IICS0 = 1010×110B  
 ▲2: IICS0 = 1010×000B  
 ▲3: IICS0 = 1010×000B (Sets the WTIM0 bit to 1)<sup>Note</sup>  
 ▲4: IICS0 = 1010××00B (Sets the SPT0 bit to 1)  
 △5: IICS0 = 00000001B

**Note** To generate a stop condition, set the WTIM0 bit to 1 and change the timing for generating the INTIICA0 interrupt request signal.

**Remark** ▲: Always generated  
 △: Generated only when SPIE0 = 1  
 x: Don't care

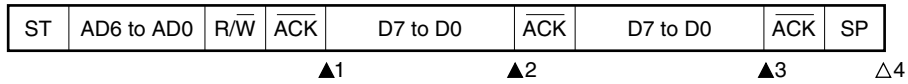
(ii) When WTIM0 = 1

ST	AD6 to AD0	R $\bar{W}$	ACK	D7 to D0	ACK	D7 to D0	ACK	SP
			▲1		▲2		▲3	△4

SPT0 = 1  
↓

▲1: IICS0 = 1010×110B  
 ▲2: IICS0 = 1010×100B  
 ▲3: IICS0 = 1010××00B (Sets the SPT0 bit to 1)  
 △4: IICS0 = 00001001B

**Remark** ▲: Always generated  
 △: Generated only when SPIE0 = 1  
 x: Don't care

**(2) Slave device operation (slave address data reception)****(a) Start ~ Address ~ Data ~ Data ~ Stop****(i) When WTIM0 = 0**

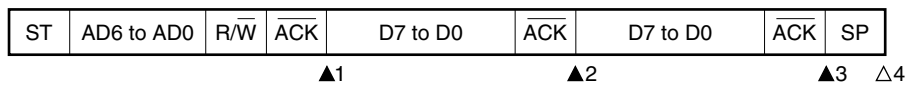
▲1: IICS0 = 0001x110B

▲2: IICS0 = 0001x000B

▲3: IICS0 = 0001x000B

△4: IICS0 = 00000001B

**Remark** ▲: Always generated  
 △: Generated only when SPIE0 = 1  
 x: Don't care

**(ii) When WTIM0 = 1**

▲1: IICS0 = 0001x110B

▲2: IICS0 = 0001x100B

▲3: IICS0 = 0001xx00B

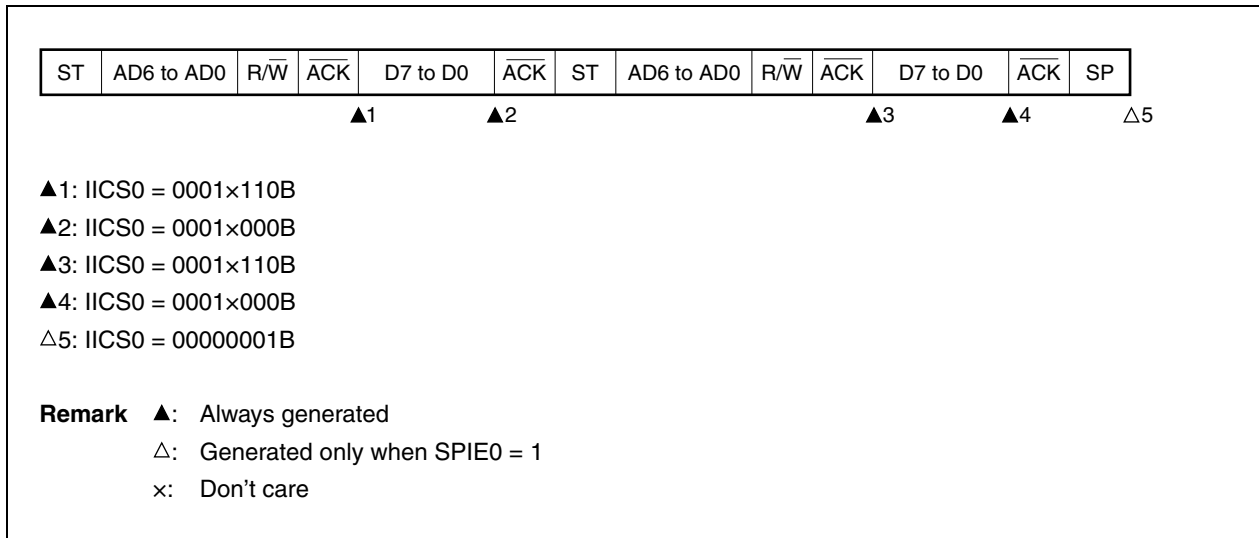
△4: IICS0 = 00000001B

**Remark** ▲: Always generated

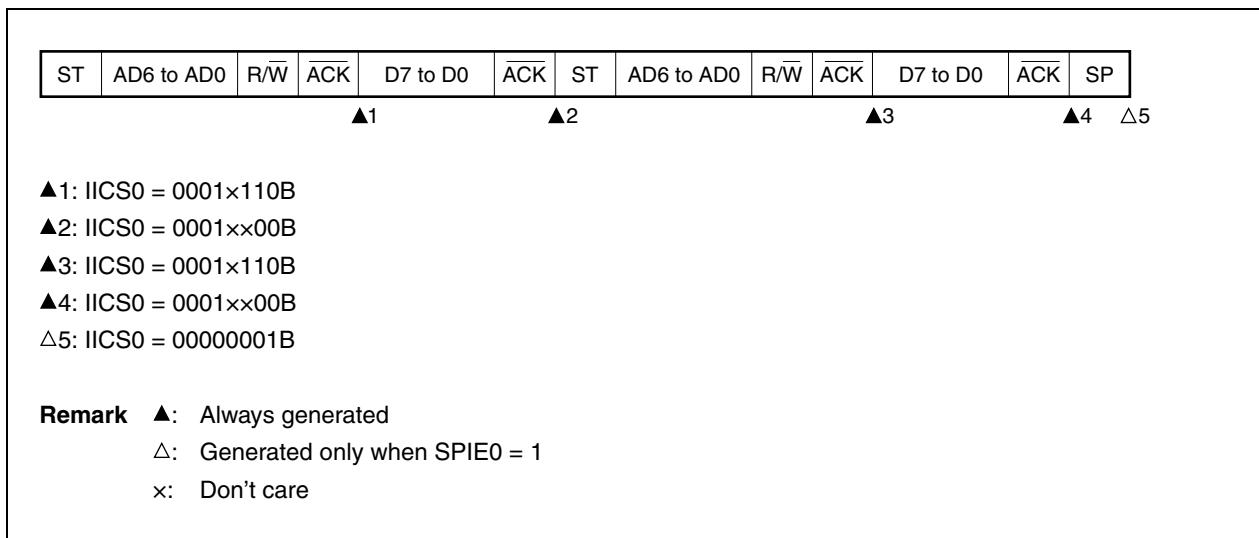
x: Don't care

**(b) Start ~ Address ~ Data ~ Start ~ Address ~ Data ~ Stop**

**(i) When WTIM0 = 0 (after restart, matches with SVA0)**

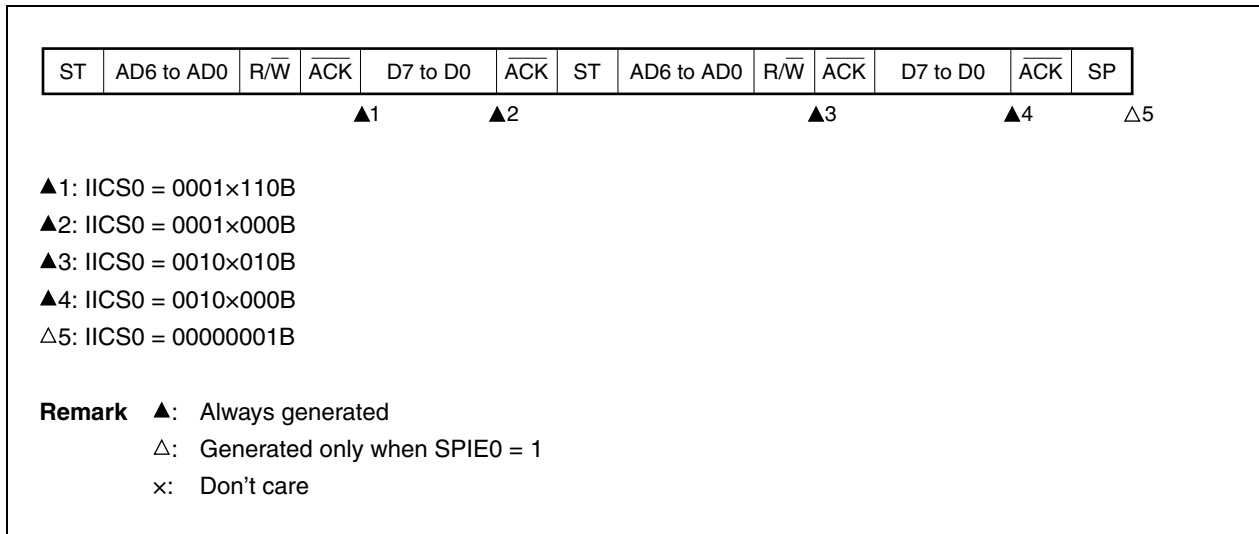


**(ii) When WTIM0 = 1 (after restart, matches with SVA0)**

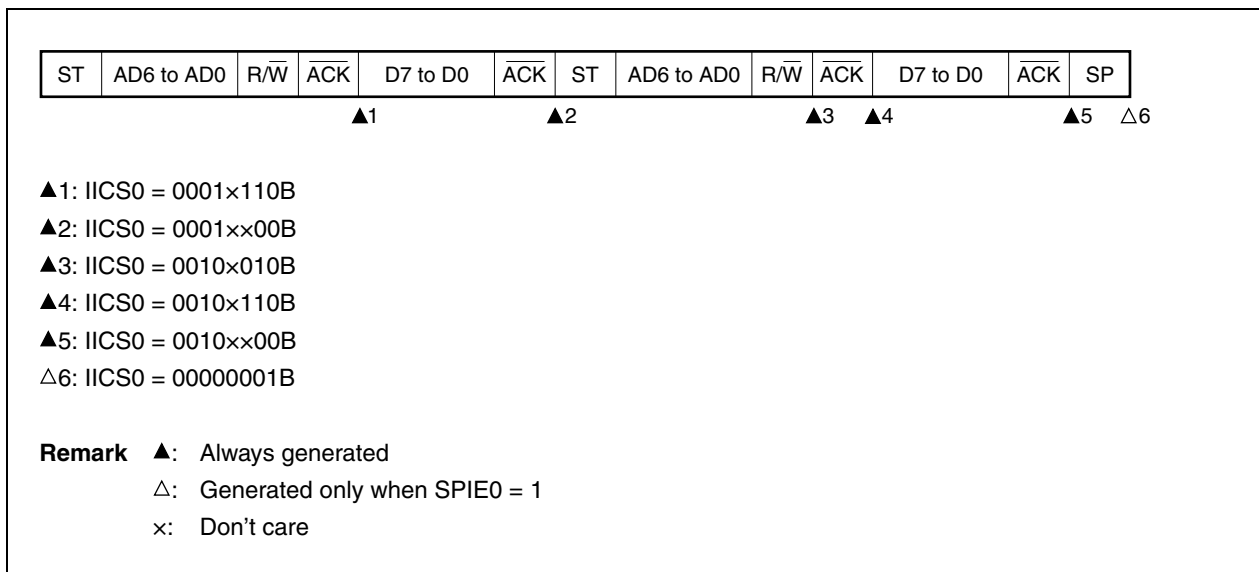


(c) Start ~ Address ~ Data ~ Start ~ Code ~ Data ~ Stop

(i) When WTIM0 = 0 (after restart, does not match address (= extension code))

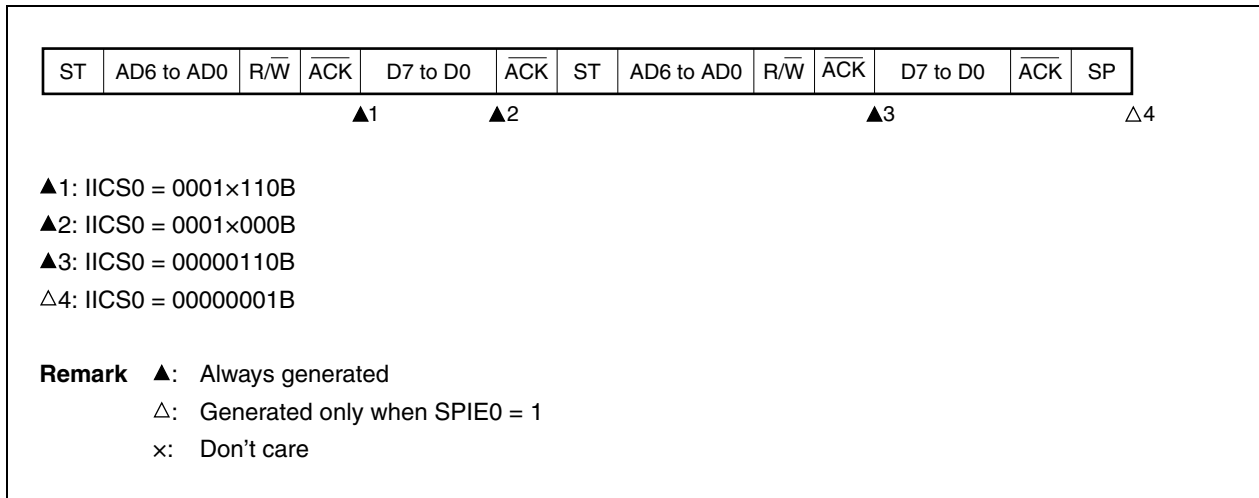


(ii) When WTIM0 = 1 (after restart, does not match address (= extension code))

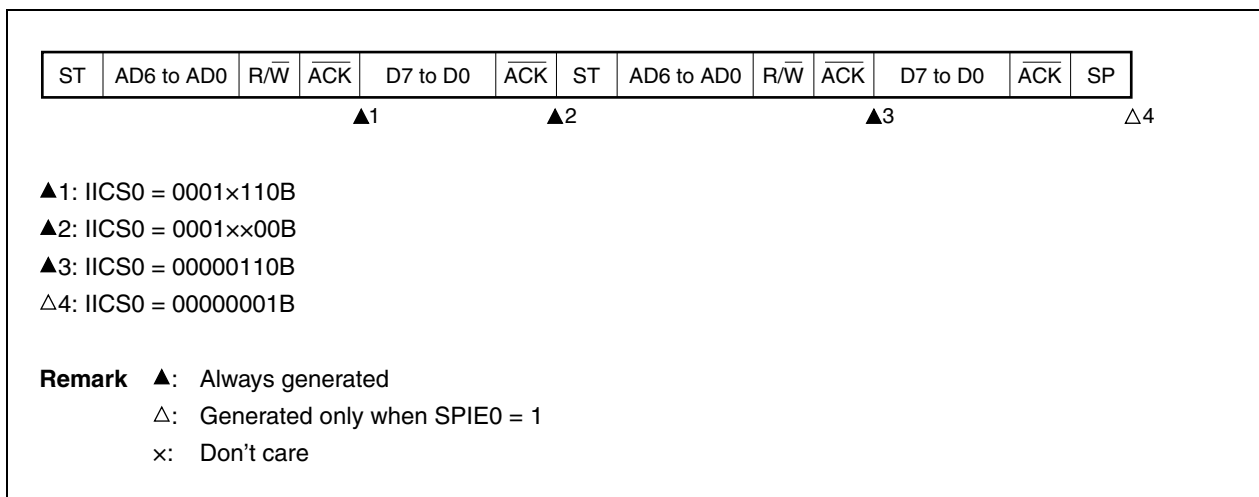


(d) Start ~ Address ~ Data ~ Start ~ Address ~ Data ~ Stop

(i) When  $WTIM0 = 0$  (after restart, does not match address (= not extension code))



(ii) When  $WTIM0 = 1$  (after restart, does not match address (= not extension code))

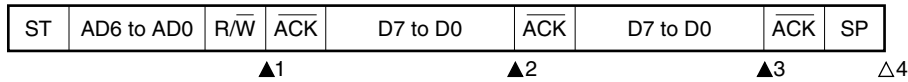


**(3) Slave device operation (when receiving extension code)**

The device is always participating in communication when it receives an extension code.

**(a) Start ~ Code ~ Data ~ Data ~ Stop**

**(i) When WTIM0 = 0**



▲1: IICS0 = 0010x010B

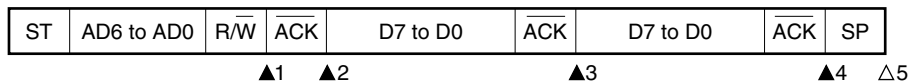
▲2: IICS0 = 0010x000B

▲3: IICS0 = 0010x000B

△4: IICS0 = 00000001B

**Remark** ▲: Always generated  
 △: Generated only when SPIE0 = 1  
 x: Don't care

**(ii) When WTIM0 = 1**



▲1: IICS0 = 0010x010B

▲2: IICS0 = 0010x110B

▲3: IICS0 = 0010x100B

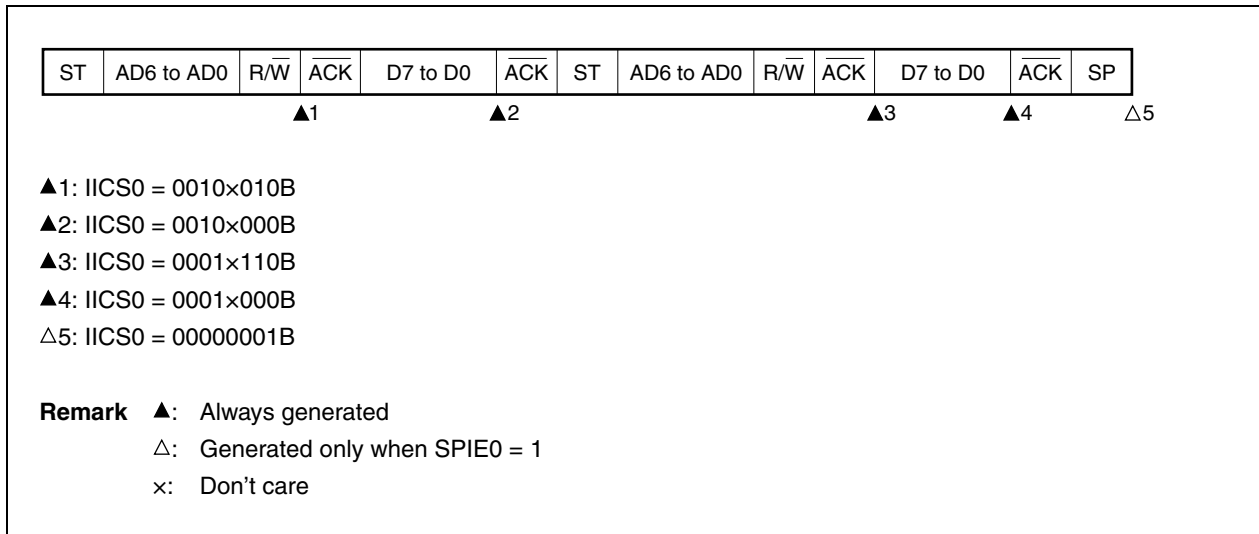
▲4: IICS0 = 0010xx00B

△5: IICS0 = 00000001B

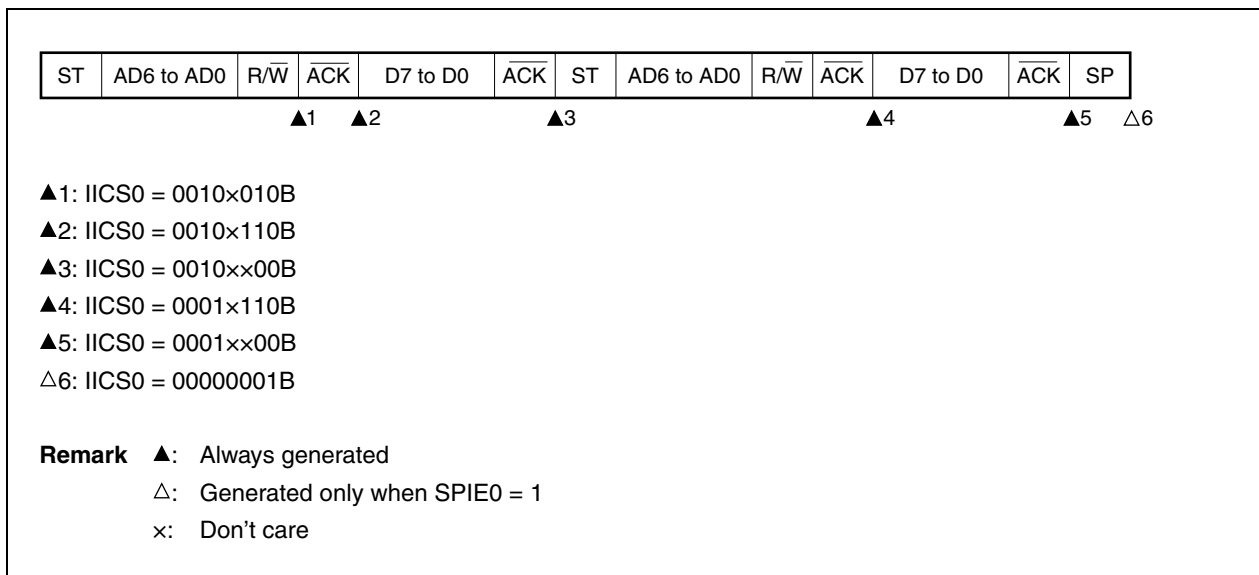
**Remark** ▲: Always generated  
 △: Generated only when SPIE0 = 1  
 x: Don't care

**(b) Start ~ Code ~ Data ~ Start ~ Address ~ Data ~ Stop**

**(i) When WTIMO = 0 (after restart, matches SVA0)**



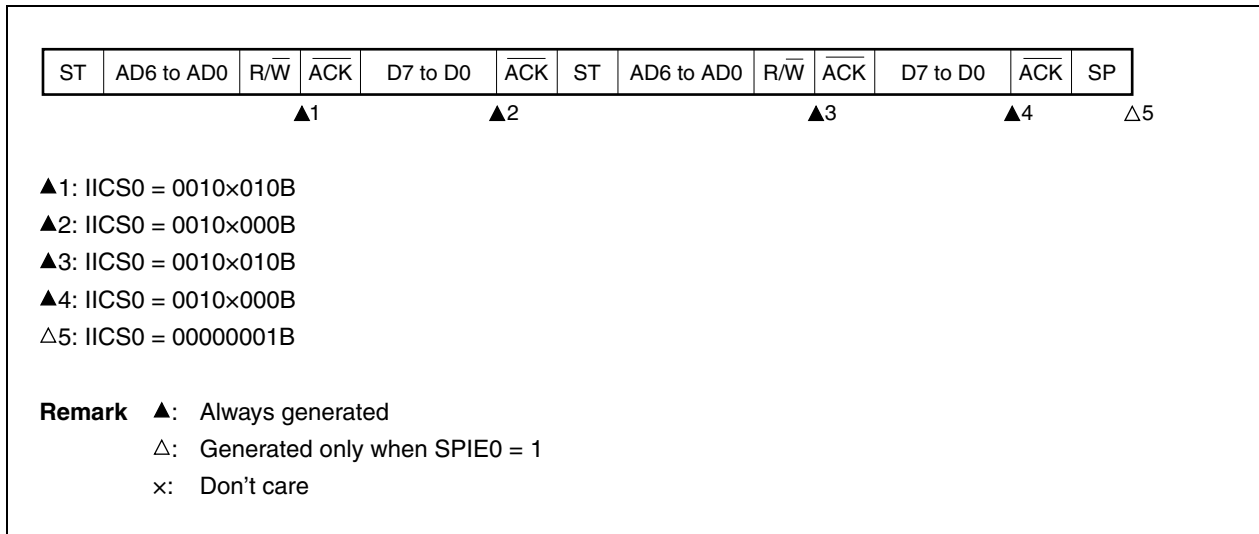
**(ii) When WTIMO = 1 (after restart, matches SVA0)**



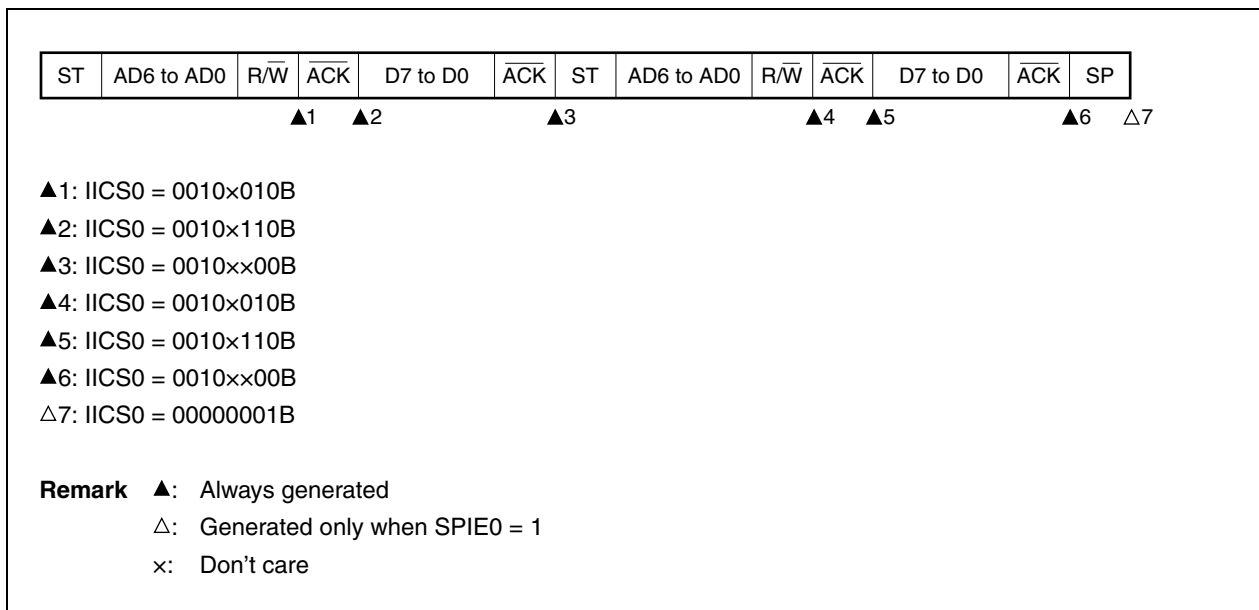


(c) Start ~ Code ~ Data ~ Start ~ Code ~ Data ~ Stop

(i) When WTIM0 = 0 (after restart, extension code reception)

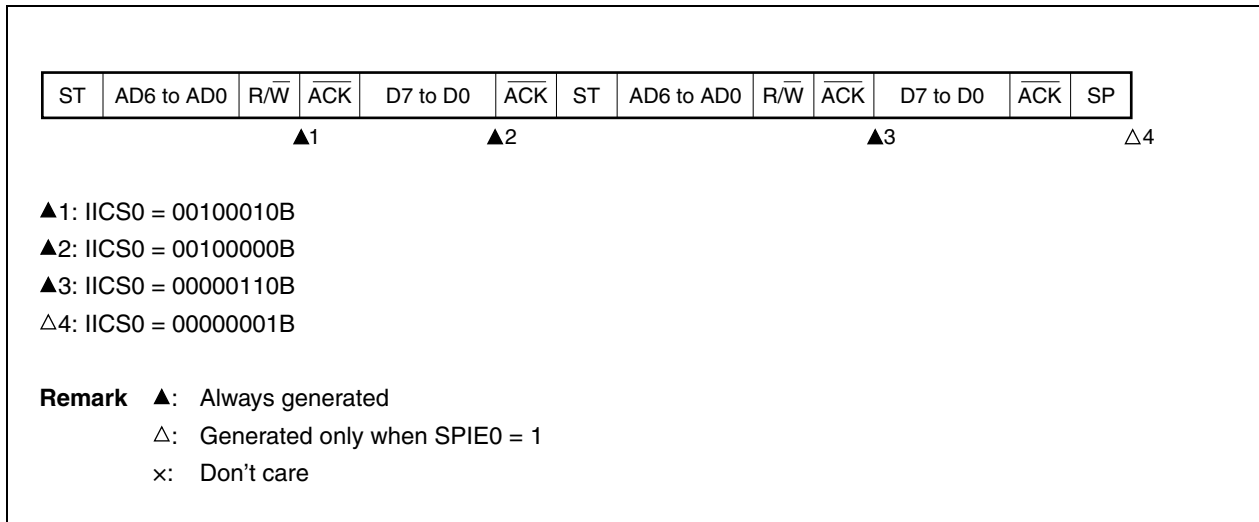


(ii) When WTIM0 = 1 (after restart, extension code reception)

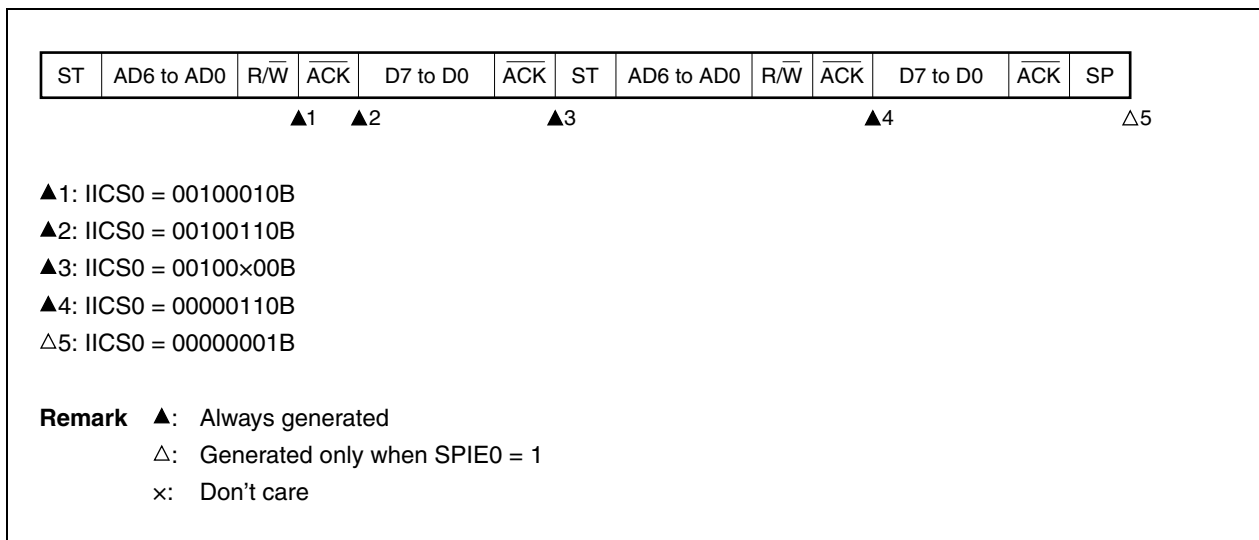


(d) Start ~ Code ~ Data ~ Start ~ Address ~ Data ~ Stop

(i) When WTIM0 = 0 (after restart, does not match address (= not extension code))

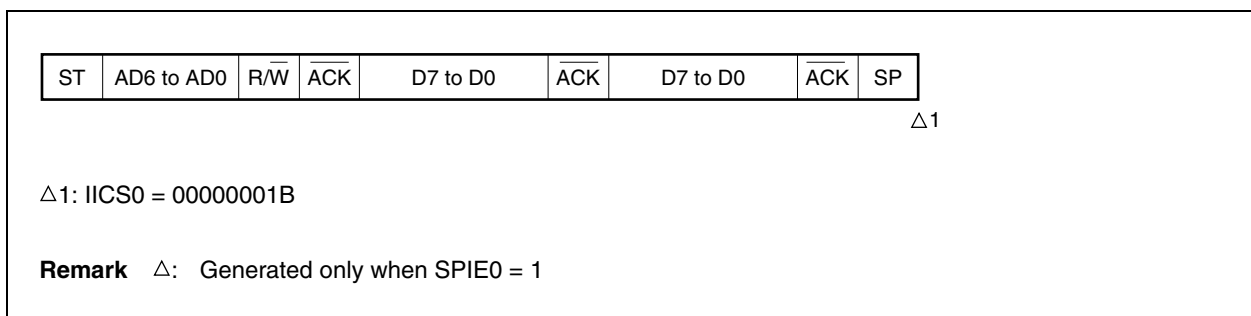


(ii) When WTIM0 = 1 (after restart, does not match address (= not extension code))



**(4) Operation without communication**

**(a) Start ~ Code ~ Data ~ Data ~ Stop**

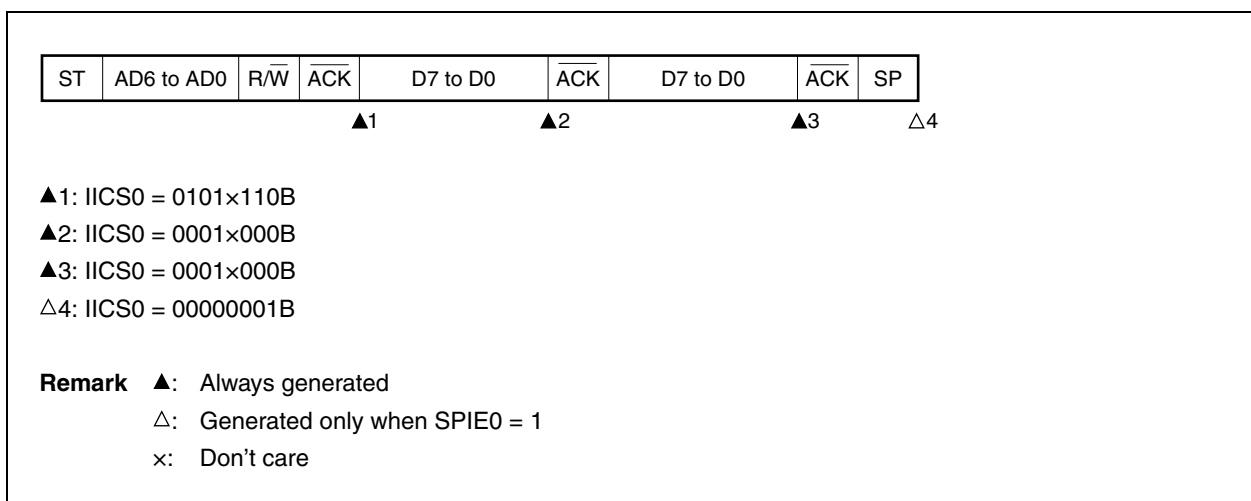


**(5) Arbitration loss operation (operation as slave after arbitration loss)**

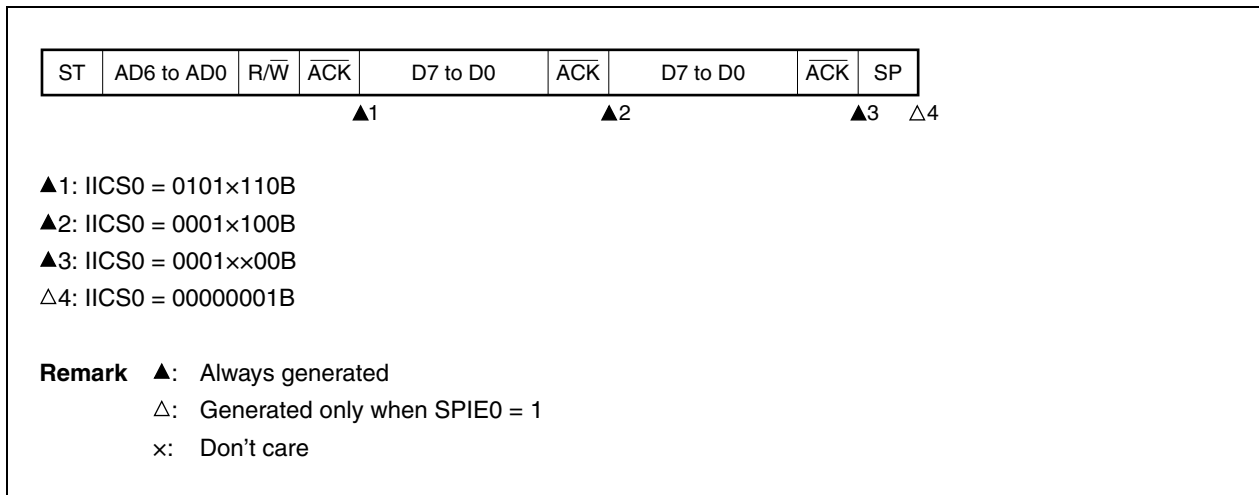
When the device is used as a master in a multi-master system, read the MSTS0 bit each time interrupt request signal INTIICA0 has occurred to check the arbitration result.

**(a) When arbitration loss occurs during transmission of slave address data**

**(i) When WTIMO = 0**

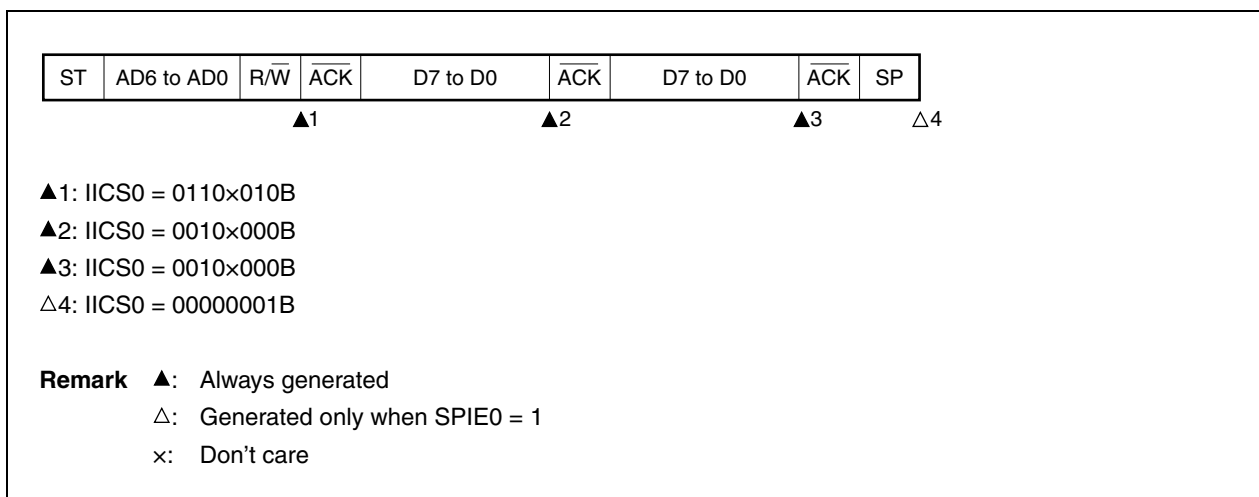


(ii) When WTIM0 = 1

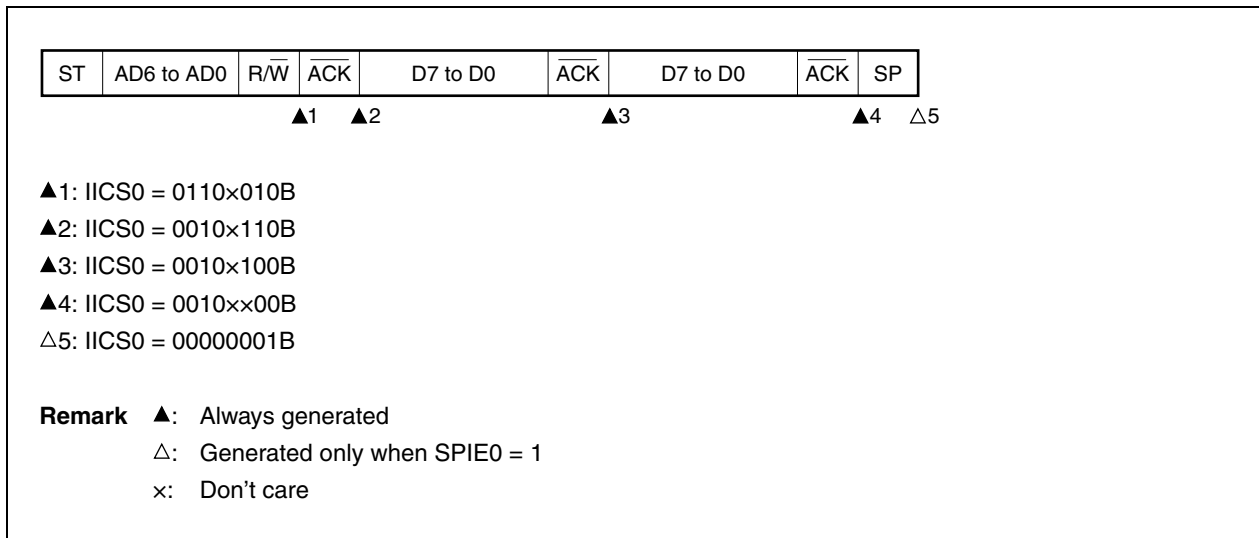


(b) When arbitration loss occurs during transmission of extension code

(i) When WTIM0 = 0



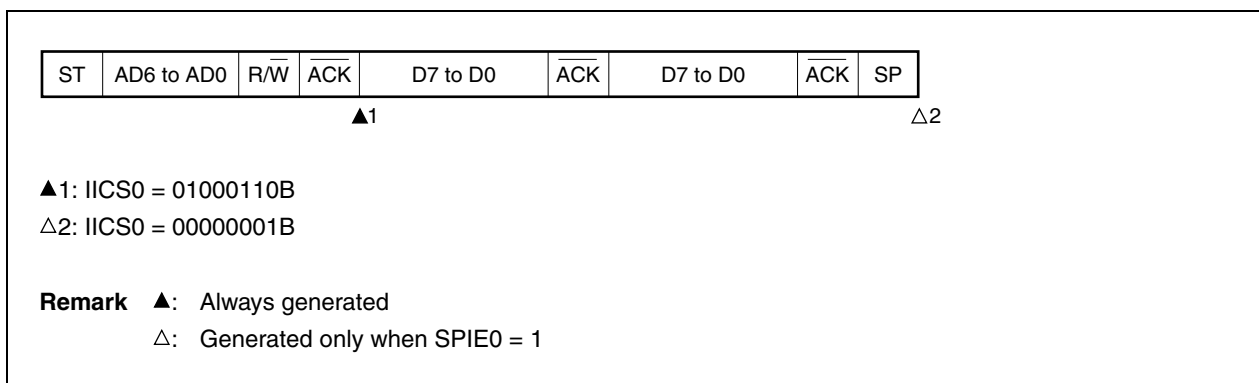
(ii) When WTIM0 = 1



(6) Operation when arbitration loss occurs (no communication after arbitration loss)

When the device is used as a master in a multi-master system, read the MSTS0 bit each time interrupt request signal INTIICA0 has occurred to check the arbitration result.

(a) When arbitration loss occurs during transmission of slave address data (when WTIM0 = 1)



**(b) When arbitration loss occurs during transmission of extension code**

ST	AD6 to AD0	R/W	ACK	D7 to D0	ACK	D7 to D0	ACK	SP
			▲1				△2	

▲1: IICS0 = 0110x010B  
 Sets LREL0 = 1 by software  
 △2: IICS0 = 00000001B

**Remark** ▲: Always generated  
 △: Generated only when SPIE0 = 1  
 x: Don't care

**(c) When arbitration loss occurs during transmission of data**

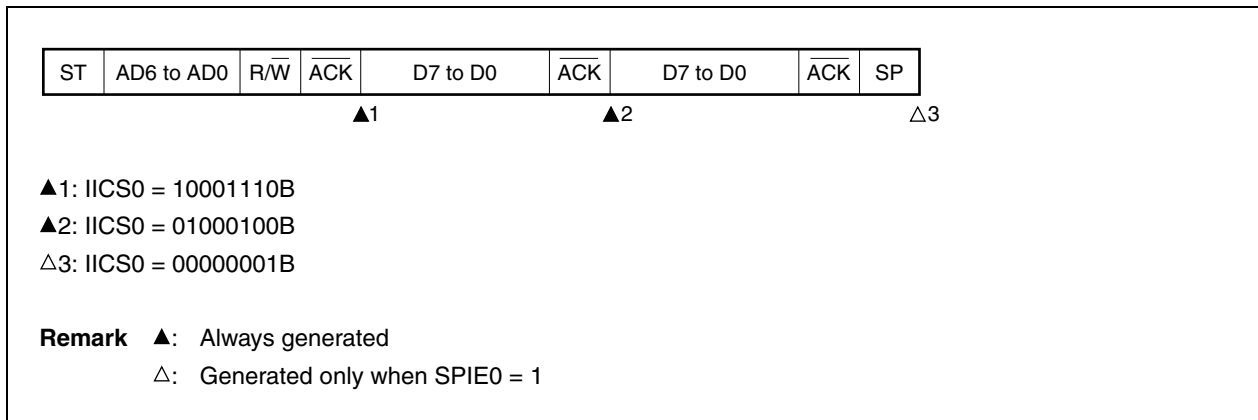
**(i) When WTIMO = 0**

ST	AD6 to AD0	R/W	ACK	D7 to D0	ACK	D7 to D0	ACK	SP
			▲1		▲2			△3

▲1: IICS0 = 10001110B  
 ▲2: IICS0 = 01000000B  
 △3: IICS0 = 00000001B

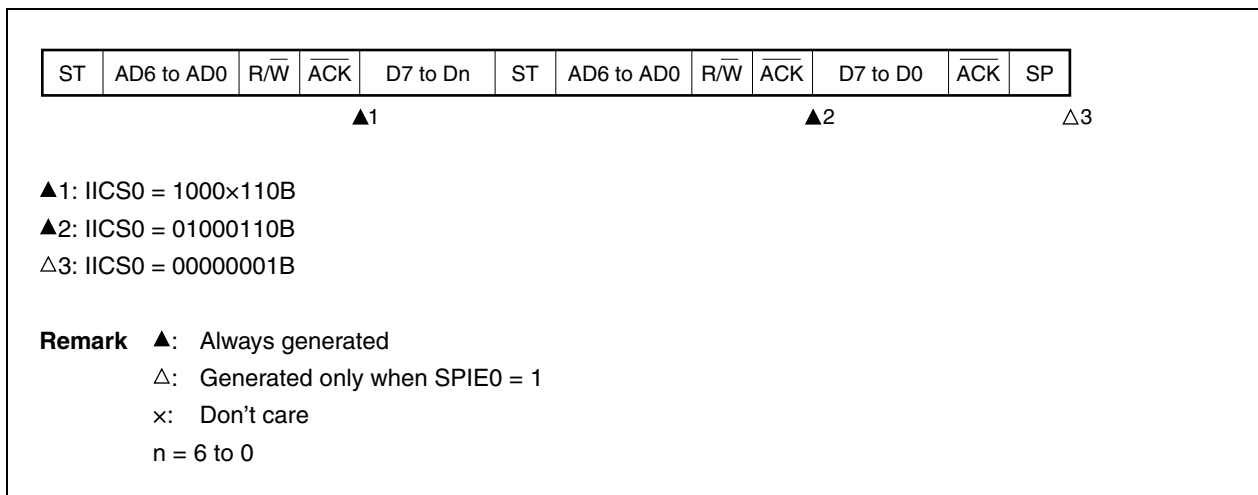
**Remark** ▲: Always generated  
 △: Generated only when SPIE0 = 1

## (ii) When WTIMO = 1

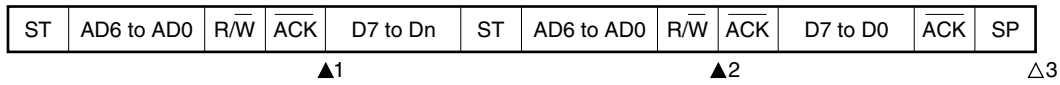


## (d) When loss occurs due to restart condition during data transfer

## (i) Not extension code (Example: unmatched with SVA0)



## (ii) Extension code



▲1: IICS0 = 1000×110B

▲2: IICS0 = 01100010B

Sets LREL0 = 1 by software

△3: IICS0 = 00000001B

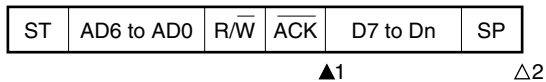
**Remark** ▲: Always generated

△: Generated only when SPIE0 = 1

x: Don't care

n = 6 to 0

## (e) When loss occurs due to stop condition during data transfer



▲1: IICS0 = 10000110B

△2: IICS0 = 01000001B

**Remark** ▲: Always generated

△: Generated only when SPIE0 = 1

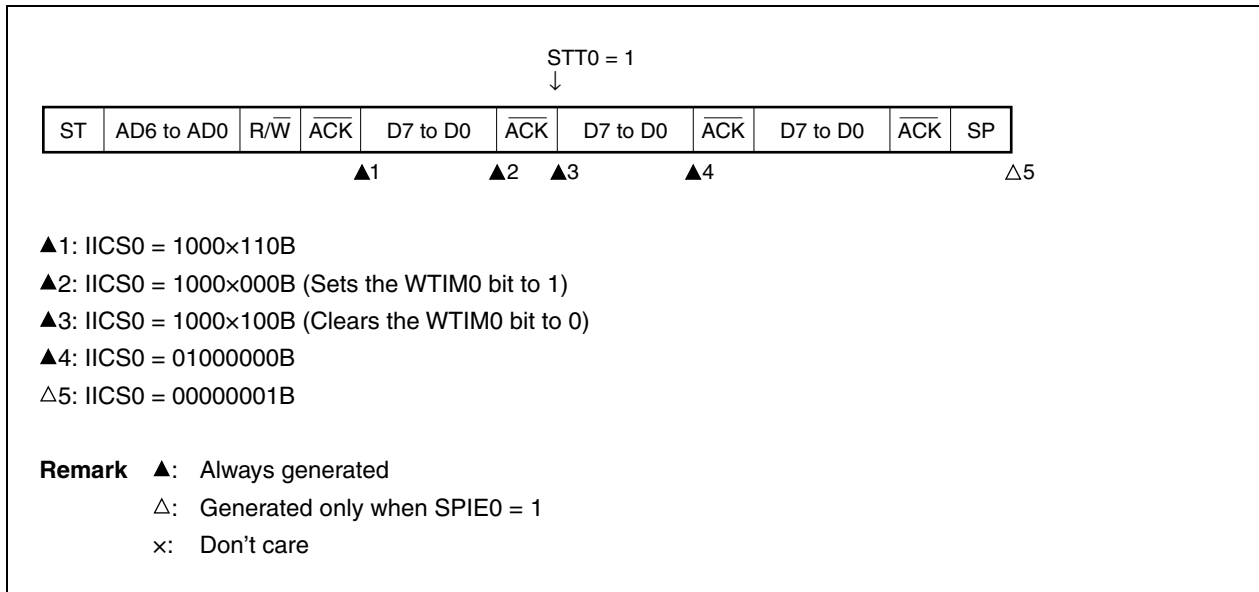
x: Don't care

n = 6 to 0

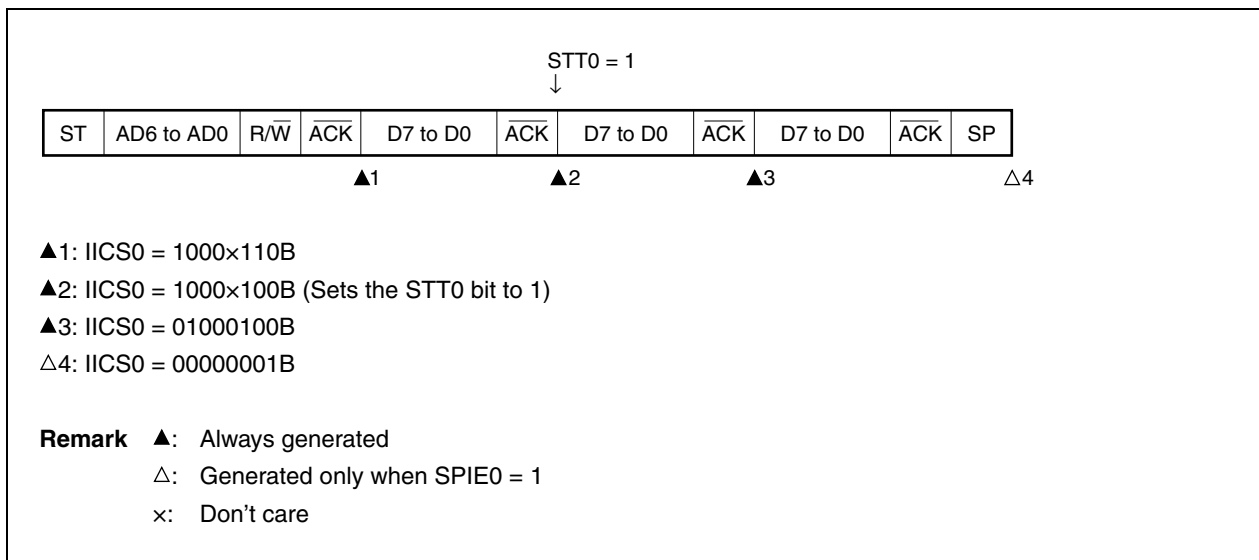


(f) When arbitration loss occurs due to low-level data when attempting to generate a restart condition

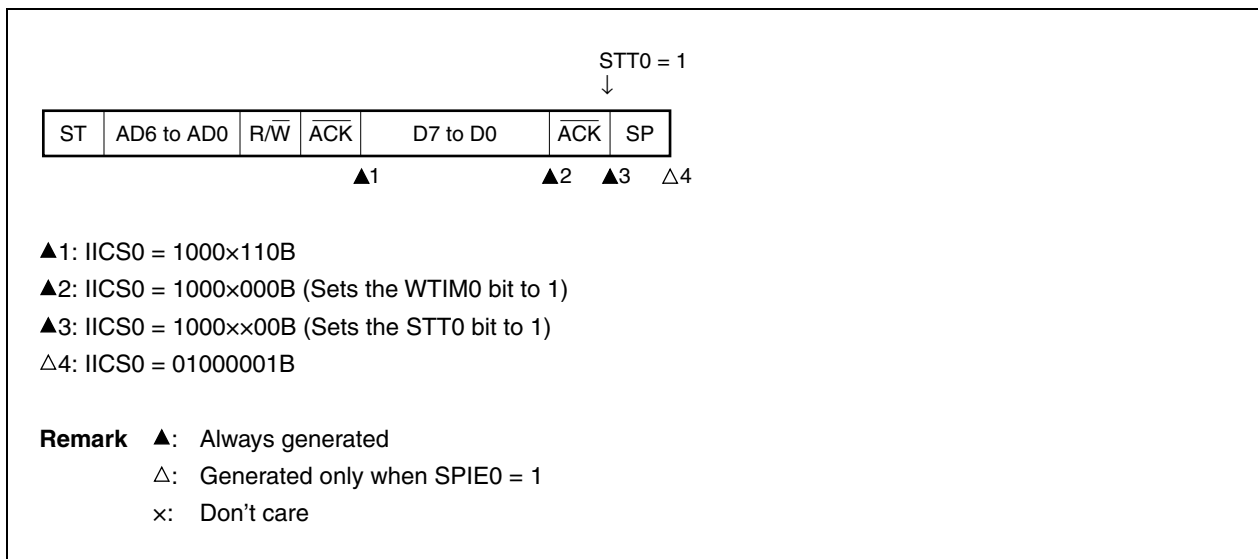
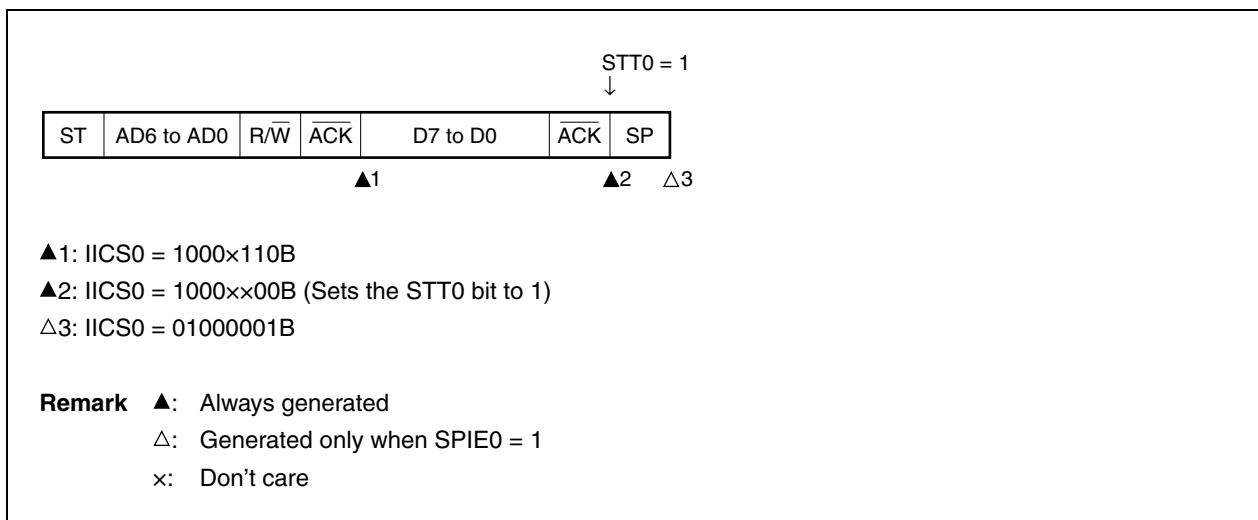
(i) When **WTIM0 = 0**



(ii) When **WTIM0 = 1**

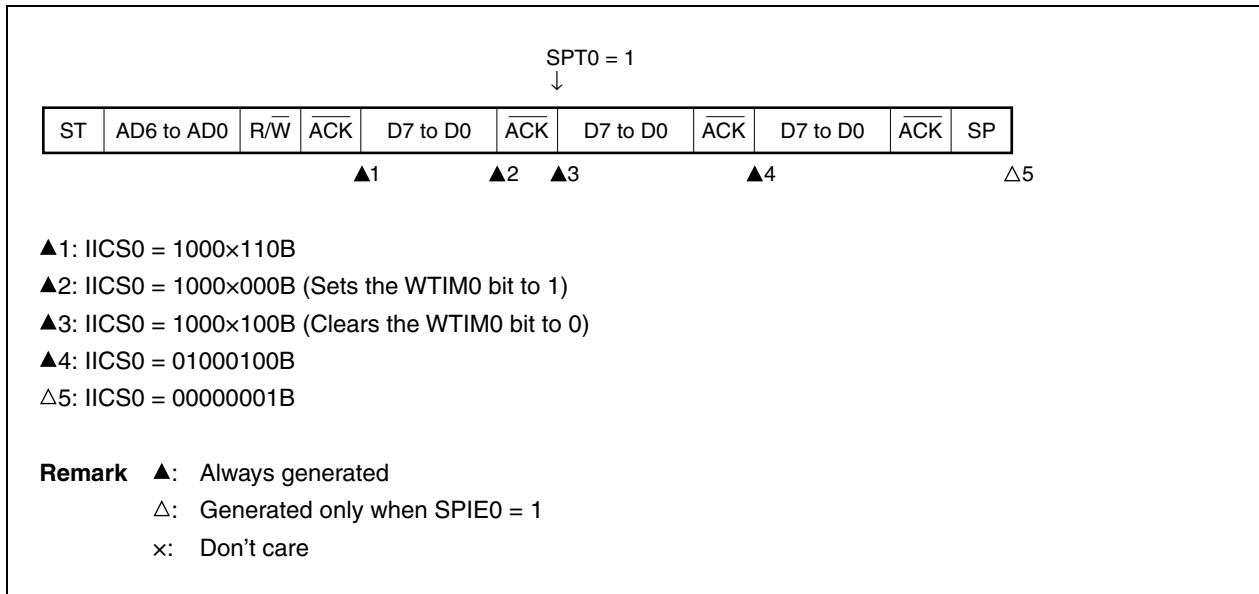


## (g) When arbitration loss occurs due to a stop condition when attempting to generate a restart condition

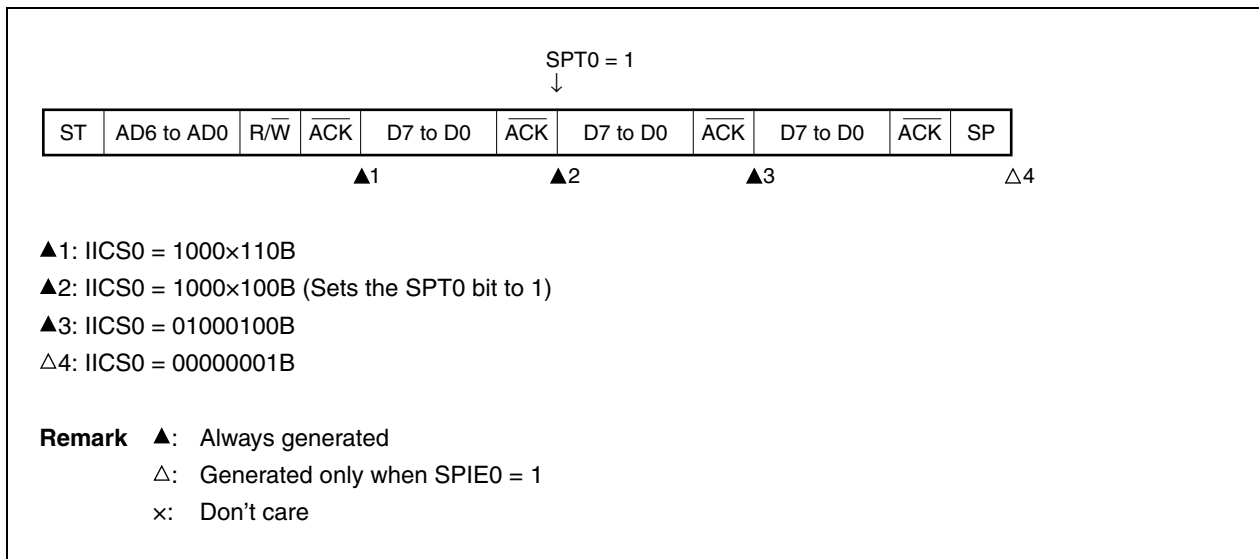
(i) When  $WTIM0 = 0$ (ii) When  $WTIM0 = 1$ 

(h) When arbitration loss occurs due to low-level data when attempting to generate a stop condition

(i) When **WTIM0 = 0**



(ii) When **WTIM0 = 1**



### 13.6 Timing Charts

When using the I<sup>2</sup>C bus mode, the master device outputs an address via the serial bus to select one of several slave devices as its communication partner.

After outputting the slave address, the master device transmits the TRC0 bit (bit 3 of the IICA status register 0 (IICS0)), which specifies the data transfer direction, and then starts serial communication with the slave device.

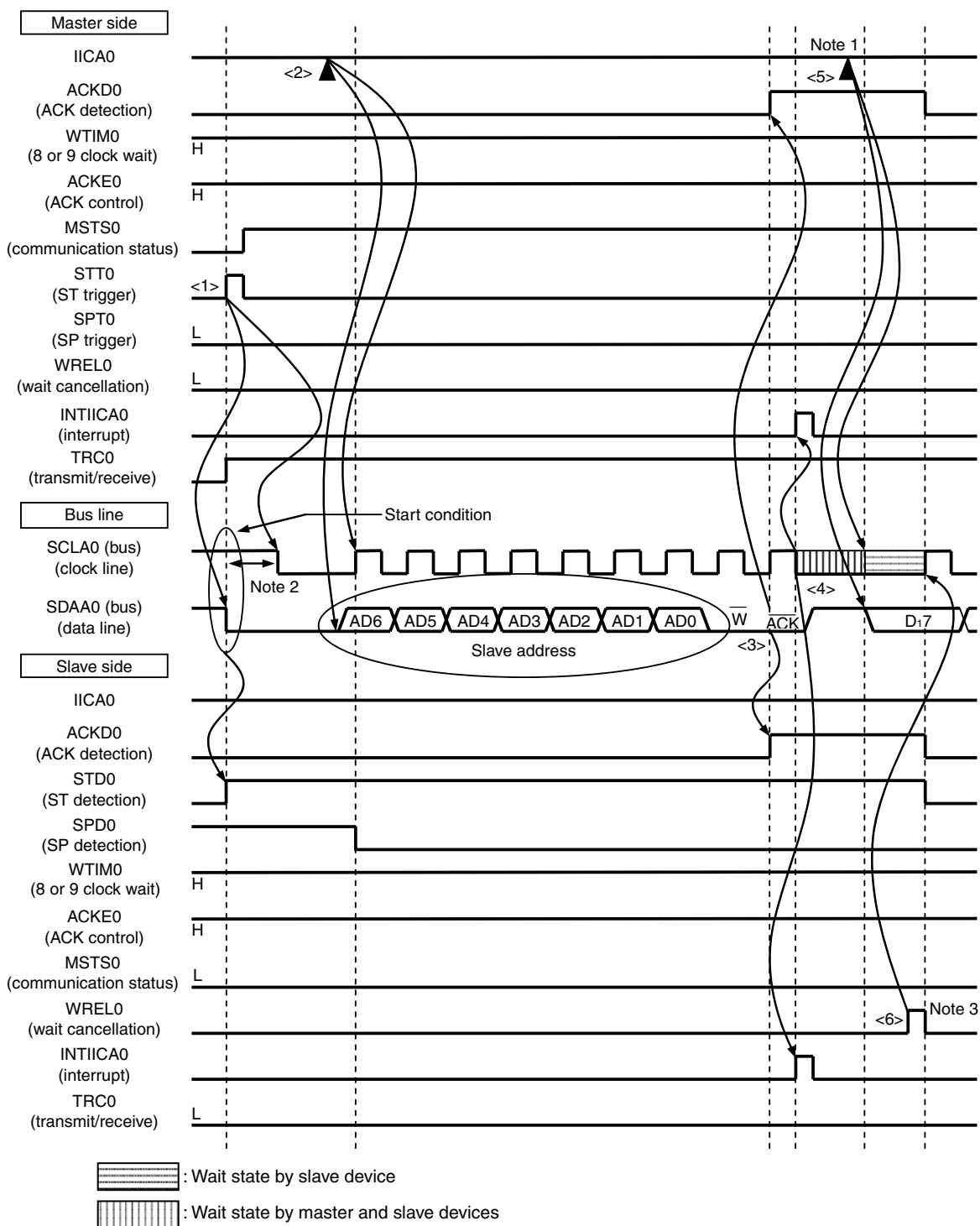
Figures 13-32 and 13-33 show timing charts of the data communication.

The IICA shift register 0 (IICA0)'s shift operation is synchronized with the falling edge of the serial clock (SCLA0). The transmit data is transferred to the SO latch and is output (MSB first) via the SDAA0 pin.

Data input via the SDAA0 pin is captured into IICA0 at the rising edge of SCLA0.

**Figure 13-32. Example of Master to Slave Communication**  
**(9-Clock Wait Is Selected for Master, 9-Clock Wait Is Selected for Slave) (1/4)**

**(1) Start condition ~ address ~ data**



- Notes 1.** Write data to IICA0, not setting the WRELO bit, in order to cancel a wait state during transmission by a master device.
- 2.** Make sure that the time between the fall of the SDA0 pin signal and the fall of the SCLA0 pin signal is at least 4.0  $\mu$ s when specifying standard mode and at least 0.6  $\mu$ s when specifying fast mode.
- 3.** For releasing wait state during reception of a slave device, write "FFH" to IICA0 or set the WRELO bit.

The meanings of <1> to <6> in (1) Start condition ~ address ~ data in Figure 13-32 are explained below.

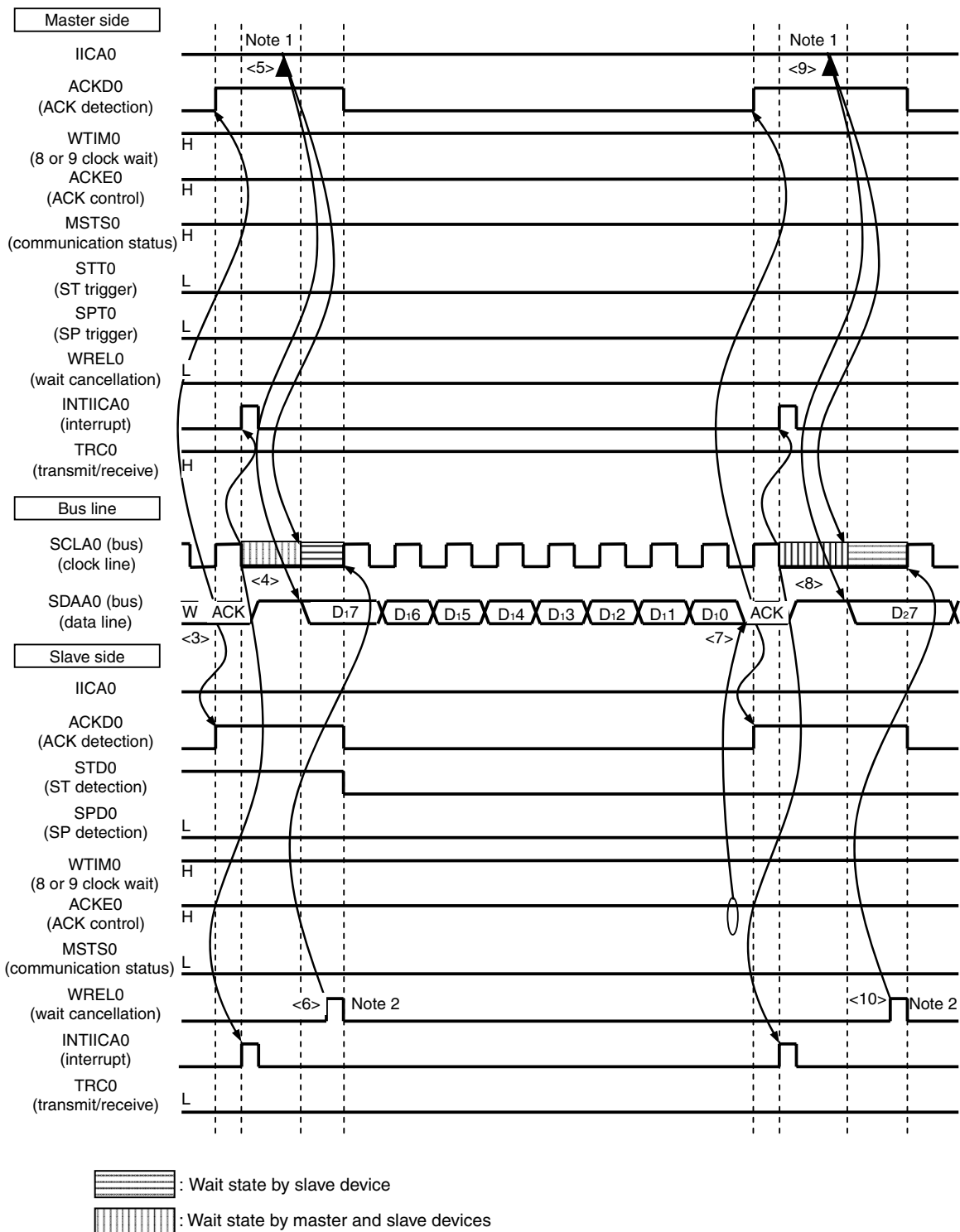
- <1> The start condition trigger is set by the master device (STT0 = 1) and a start condition (i.e. SCLA0 = 1 changes SDAA0 from 1 to 0) is generated once the bus data line goes low (SDAA0). When the start condition is subsequently detected, the master device enters the master device communication status (MSTS0 = 1). The master device is ready to communicate once the bus clock line goes low (SCLA0 = 0) after the hold time has elapsed.
- <2> The master device writes the address + W (transmission) to the IICA shift register 0 (IICA0) and transmits the slave address.
- <3> In the slave device if the address received matches the address (SVA0 value) of a slave device<sup>Note</sup>, that slave device sends an ACK by hardware to the master device. The ACK is detected by the master device (ACKD0 = 1) at the rising edge of the 9th clock.
- <4> The master device issues an interrupt (INTIICA0: end of address transmission) at the falling edge of the 9th clock. The slave device whose address matched the transmitted slave address sets a wait status (SCLA0 = 0) and issues an interrupt (INTIICA0: address match)<sup>Note</sup>.
- <5> The master device writes the data to transmit to the IICA0 register and releases the wait status that it set by the master device.
- <6> If the slave device releases the wait status (WREL0 = 1), the master device starts transferring data to the slave device.

**Note** If the transmitted address does not match the address of the slave device, the slave device does not return an ACK to the master device (NACK: SDAA0 = 1). The slave device also does not issue the INTIICA0 interrupt (address match) and does not set a wait status. The master device, however, issues the INTIICA0 interrupt (end of address transmission) regardless of whether it receives an ACK or NACK.

**Remark** <1> to <15> in Figure 13-32 represent the entire procedure for communicating data using the I<sup>2</sup>C bus. Figure 13-32 (1) Start condition ~ address ~ data shows the processing from <1> to <6>, Figure 13-32 (2) Address ~ data ~ data shows the processing from <3> to <10>, and Figure 13-32 (3) Data ~ data ~ stop condition shows the processing from <7> to <15>.

**Figure 13-32. Example of Master to Slave Communication  
(9-Clock Wait Is Selected for Master, 9-Clock Wait Is Selected for Slave) (2/4)**

**(2) Address ~ data ~ data**



- Notes**
- Write data to IICA0, not setting the WRELO bit, in order to cancel a wait state during transmission by a master device.
  - For releasing wait state during reception of a slave device, write "FFH" to IICA0 or set the WRELO bit.

The meanings of <3> to <10> in (2) Address ~ data ~ data in Figure 13-32 are explained below.

- <3> In the slave device if the address received matches the address (SVA0 value) of a slave device<sup>Note</sup>, that slave device sends an ACK by hardware to the master device. The ACK is detected by the master device (ACKD0 = 1) at the rising edge of the 9th clock.
- <4> The master device issues an interrupt (INTIICA0: end of address transmission) at the falling edge of the 9th clock. The slave device whose address matched the transmitted slave address sets a wait status (SCLA0 = 0) and issues an interrupt (INTIICA0: address match)<sup>Note</sup>.
- <5> The master device writes the data to transmit to the IICA shift register 0 (IICA0) and releases the wait status that it set by the master device.
- <6> If the slave device releases the wait status (WRELO = 1), the master device starts transferring data to the slave device.
- <7> After data transfer is completed, because of ACKEO = 1, the slave device sends an ACK by hardware to the master device. The ACK is detected by the master device (ACKD0 = 1) at the rising edge of the 9th clock.
- <8> The master device and slave device set a wait status (SCLA0 = 0) at the falling edge of the 9th clock, and both the master device and slave device issue an interrupt (INTIICA0: end of transfer).
- <9> The master device writes the data to transmit to the IICA0 register and releases the wait status that it set by the master device.
- <10> The slave device reads the received data and releases the wait status (WRELO = 1). The master device then starts transferring data to the slave device.

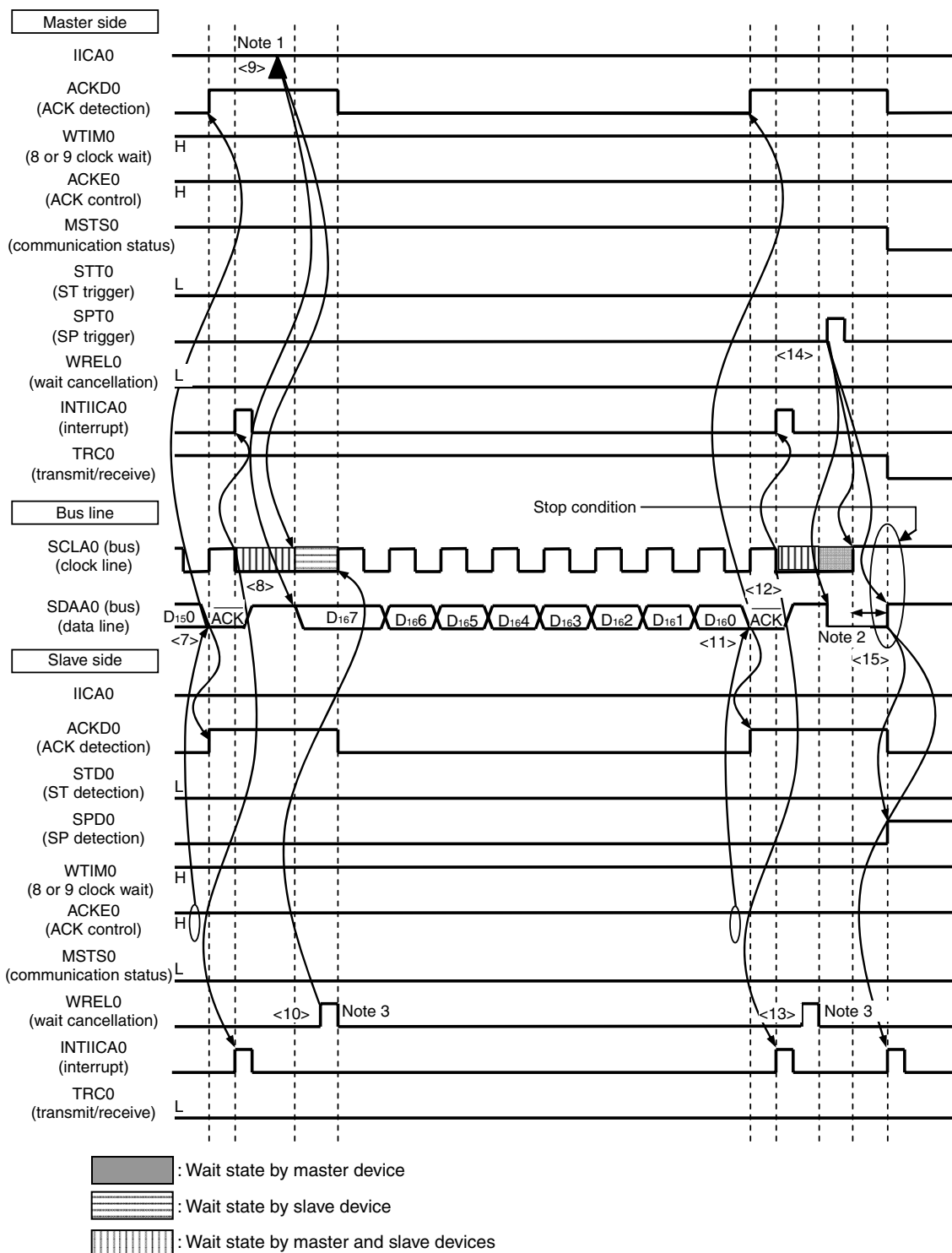
**Note** If the transmitted address does not match the address of the slave device, the slave device does not return an ACK to the master device (NACK: SDAA0 = 1). The slave device also does not issue the INTIICA0 interrupt (address match) and does not set a wait status. The master device, however, issues the INTIICA0 interrupt (end of address transmission) regardless of whether it receives an ACK or NACK.

**Remark** <1> to <15> in Figure 13-32 represent the entire procedure for communicating data using the I<sup>2</sup>C bus. Figure 13-32 (1) Start condition ~ address ~ data shows the processing from <1> to <6>, Figure 13-32 (2) Address ~ data ~ data shows the processing from <3> to <10>, and Figure 13-32 (3) Data ~ data ~ stop condition shows the processing from <7> to <15>.



**Figure 13-32. Example of Master to Slave Communication  
(9-Clock Wait Is Selected for Master, 9-Clock Wait Is Selected for Slave) (3/4)**

**(3) Data ~ data ~ Stop condition**



- Notes**
1. Write data to IICA0, not setting the WRELO bit, in order to cancel a wait state during transmission by a master device.
  2. Make sure that the time between the rise of the SCLA0 pin signal and the generation of the stop condition after a stop condition has been issued is at least 4.0  $\mu$ s when specifying standard mode and at least 0.6  $\mu$ s when specifying fast mode.
  3. For releasing wait state during reception of a slave device, write "FFH" to IICA0 or set the WRELO bit.

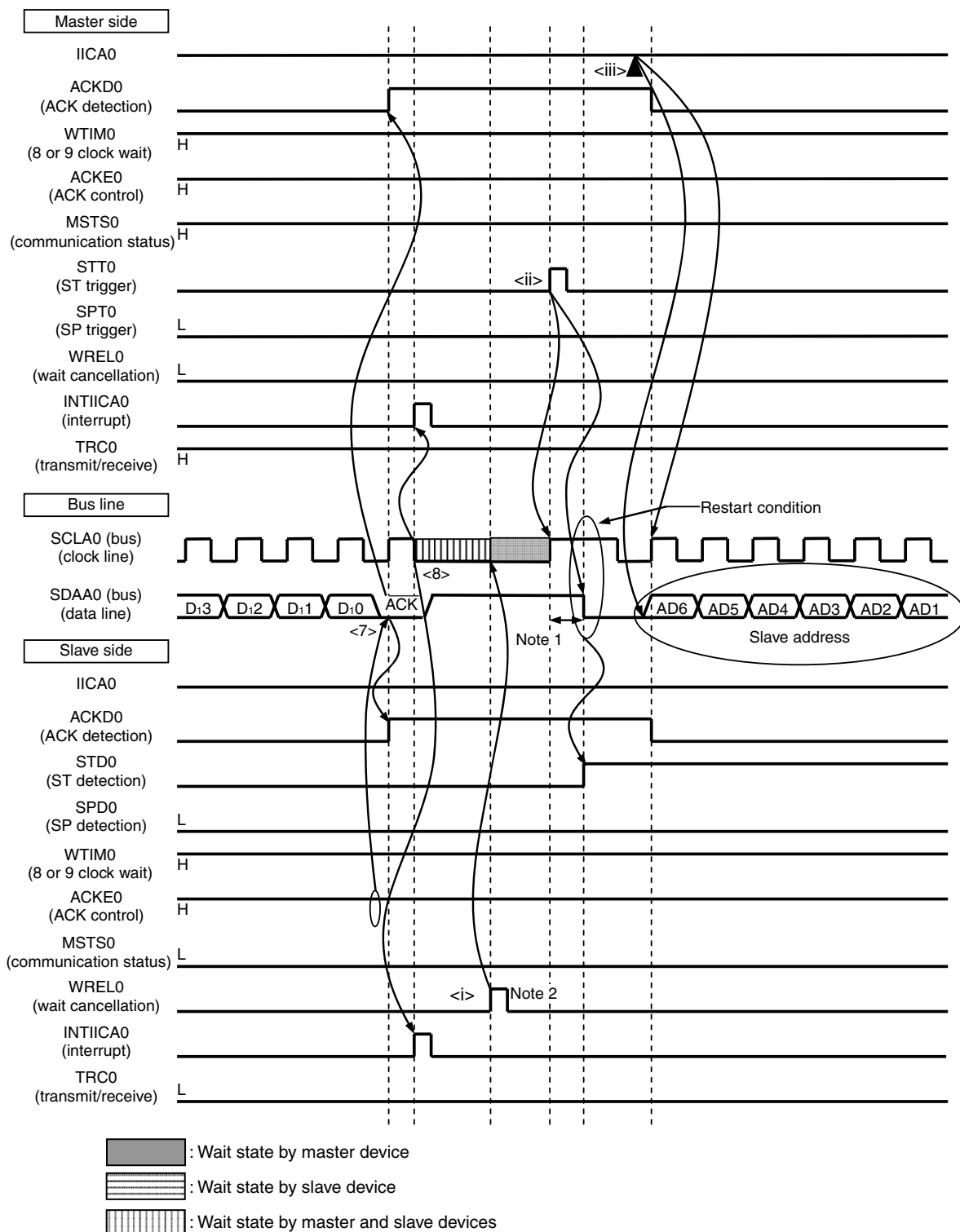
The meanings of <7> to <15> in (3) Data ~ data ~ stop condition in Figure 13-32 are explained below.

- <7> After data transfer is completed, because of  $ACKE0 = 1$ , the slave device sends an ACK by hardware to the master device. The ACK is detected by the master device ( $ACKD0 = 1$ ) at the rising edge of the 9th clock.
- <8> The master device and slave device set a wait status ( $SCLA0 = 0$ ) at the falling edge of the 9th clock, and both the master device and slave device issue an interrupt (INTIICA0: end of transfer).
- <9> The master device writes the data to transmit to the IICA shift register 0 (IICA0) and releases the wait status that it set by the master device.
- <10> The slave device reads the received data and releases the wait status ( $WREL0 = 1$ ). The master device then starts transferring data to the slave device.
- <11> When data transfer is complete, the slave device ( $ACKE0 = 1$ ) sends an ACK by hardware to the master device. The ACK is detected by the master device ( $ACKD0 = 1$ ) at the rising edge of the 9th clock.
- <12> The master device and slave device set a wait status ( $SCLA0 = 0$ ) at the falling edge of the 9th clock, and both the master device and slave device issue an interrupt (INTIICA0: end of transfer).
- <13> The slave device reads the received data and releases the wait status ( $WREL0 = 1$ ).
- <14> By the master device setting a stop condition trigger ( $SPT0 = 1$ ), the bus data line is cleared ( $SDAA0 = 0$ ) and the bus clock line is set ( $SCLA0 = 1$ ). After the stop condition setup time has elapsed, by setting the bus data line ( $SDAA0 = 1$ ), the stop condition is then generated (i.e.  $SCLA0 = 1$  changes  $SDAA0$  from 0 to 1).
- <15> When a stop condition is generated, the slave device detects the stop condition and issues an interrupt (INTIICA0: stop condition).

**Remark** <1> to <15> in Figure 13-32 represent the entire procedure for communicating data using the I<sup>2</sup>C bus. Figure 13-32 (1) Start condition ~ address ~ data shows the processing from <1> to <6>, Figure 13-32 (2) Address ~ data ~ data shows the processing from <3> to <10>, and Figure 13-32 (3) Data ~ data ~ stop condition shows the processing from <7> to <15>.

**Figure 13-32. Example of Master to Slave Communication**  
**(9-Clock Wait Is Selected for Master, 9-Clock Wait Is Selected for Slave) (4/4)**

**(4) Data ~ restart condition ~ address**



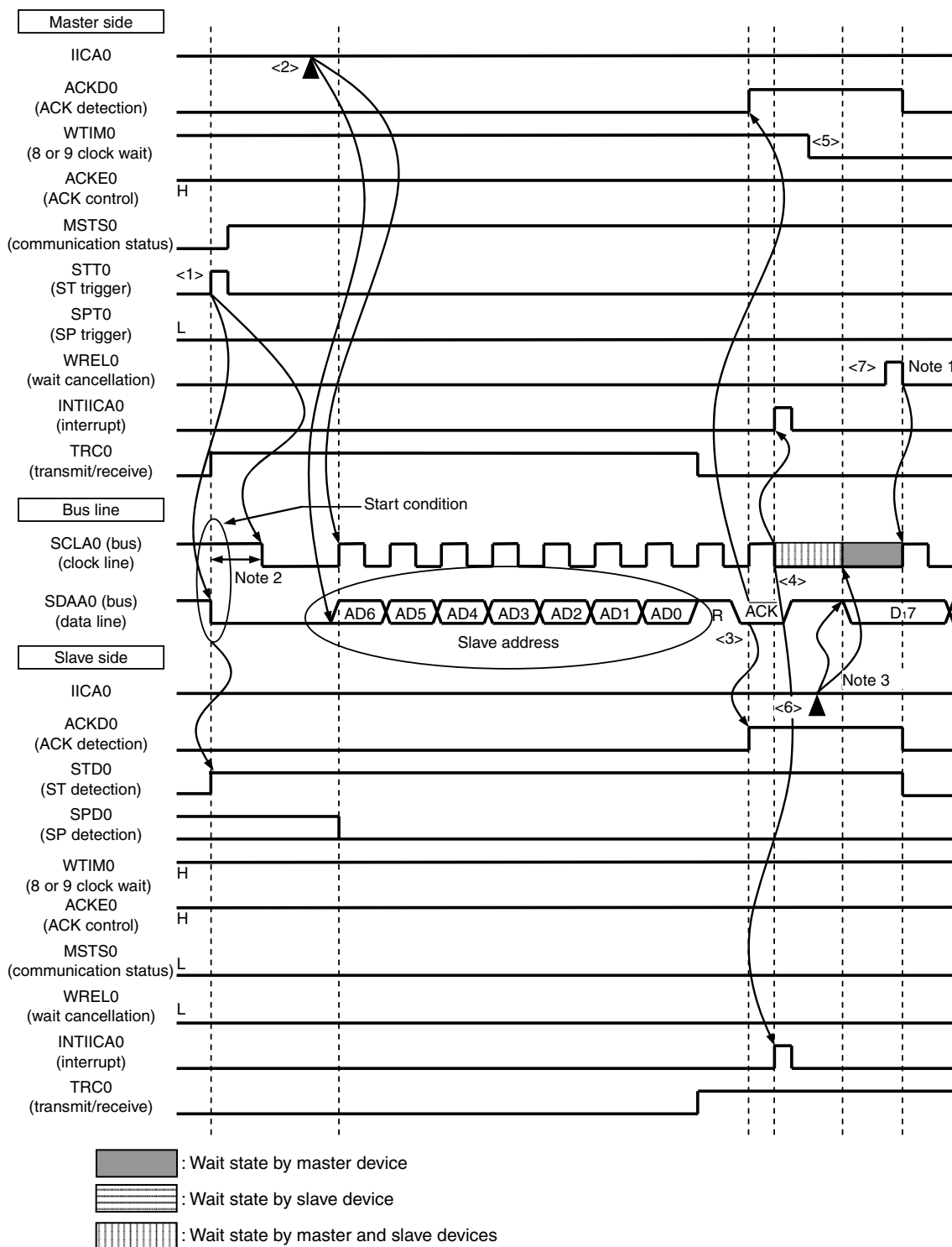
- Notes**
1. Make sure that the time between the rise of the SCLA0 pin signal and the generation of the start condition after a restart condition has been issued is at least 4.7  $\mu$ s when specifying standard mode and at least 0.6  $\mu$ s when specifying fast mode.
  2. For releasing wait state during reception of a slave device, write "FFH" to IICA0 or set the WRELO bit.

The following describes the operations in Figure 13-32 (4) Data ~ restart condition ~ address. After the operations in steps <7> and <8>, the operations in steps <i> to <iii> are performed. These steps return the processing to step <iii>, the data transmission step.

- <7> After data transfer is completed, because of  $ACKEO = 1$ , the slave device sends an ACK by hardware to the master device. The ACK is detected by the master device ( $ACKD0 = 1$ ) at the rising edge of the 9th clock.
- <8> The master device and slave device set a wait status ( $SCLA0 = 0$ ) at the falling edge of the 9th clock, and both the master device and slave device issue an interrupt ( $INTIICA0$ : end of transfer).
- <i> The slave device reads the received data and releases the wait status ( $WRELO = 1$ ).
- <ii> The start condition trigger is set again by the master device ( $STT0 = 1$ ) and a start condition (i.e.  $SCLA0 = 1$  changes  $SDAA0$  from 1 to 0) is generated once the bus clock line goes high ( $SCLA0 = 1$ ) and the bus data line goes low ( $SDAA0 = 0$ ) after the restart condition setup time has elapsed. When the start condition is subsequently detected, the master device is ready to communicate once the bus clock line goes low ( $SCLA0 = 0$ ) after the hold time has elapsed.
- <iii> The master device writing the address + R/W (transmission) to the IICA shift register ( $IICA0$ ) enables the slave address to be transmitted.

**Figure 13-33. Example of Slave to Master Communication  
(8-Clock Wait Is Selected for Master, 9-Clock Wait Is Selected for Slave) (1/3)**

**(1) Start condition ~ address ~ data**



- Notes**
- For releasing wait state during reception of a master device, write "FFH" to IICA0 or set the WRELO bit.
  - Make sure that the time between the fall of the SDA0 pin signal and the fall of the SCLA0 pin signal is at least 4.0  $\mu$ s when specifying standard mode and at least 0.6  $\mu$ s when specifying fast mode.
  - Write data to IICA0, not setting the WRELO bit, in order to cancel a wait state during transmission by a slave device.

The meanings of <1> to <7> in (1) Start condition ~ address ~ data in Figure 13-33 are explained below.

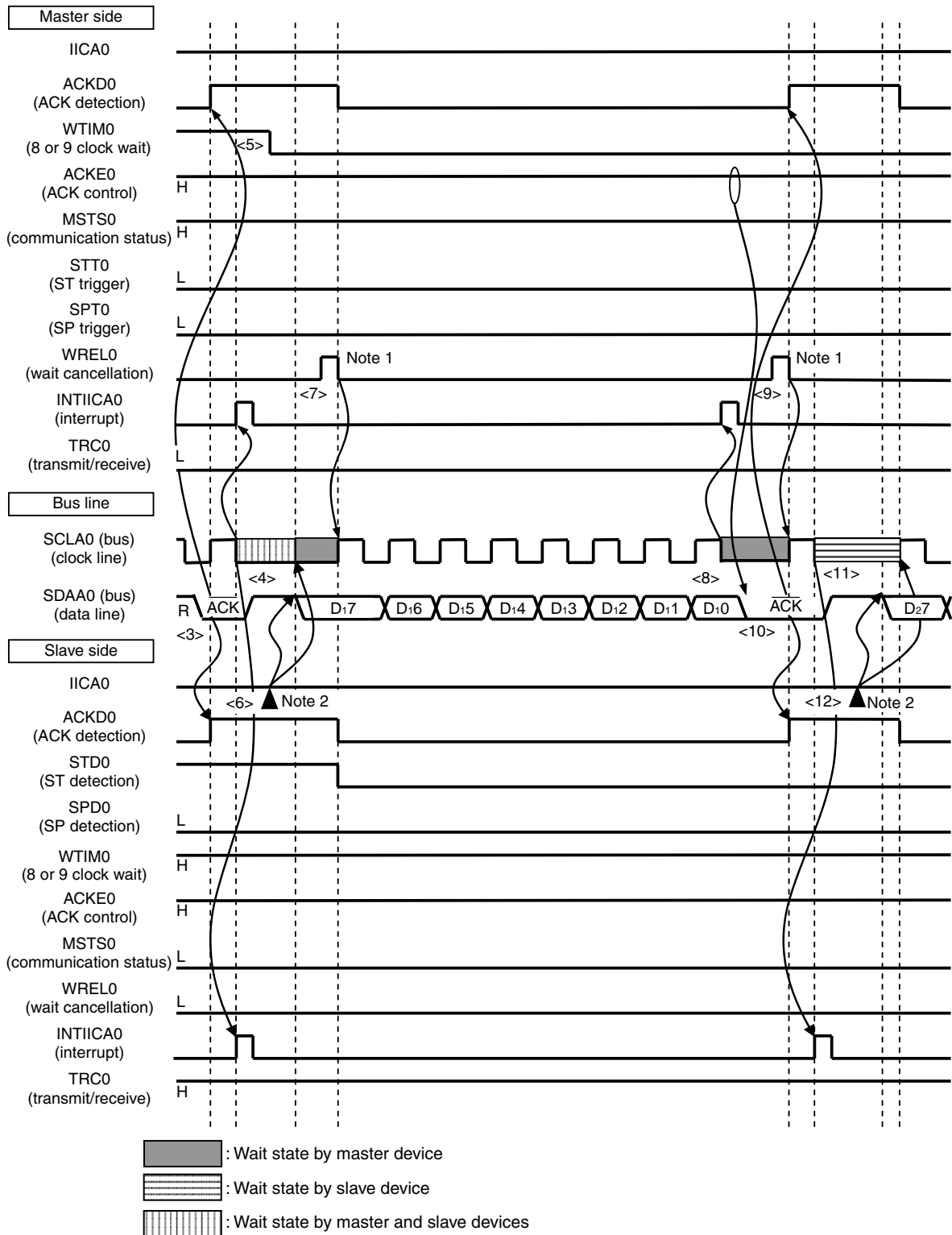
- <1> The start condition trigger is set by the master device (STT0 = 1) and a start condition (i.e. SCLA0 = 1 changes SDAA0 from 1 to 0) is generated once the bus data line goes low (SDAA0). When the start condition is subsequently detected, the master device enters the master device communication status (MSTS0 = 1). The master device is ready to communicate once the bus clock line goes low (SCLA0 = 0) after the hold time has elapsed.
- <R> <2> The master device writes the address + R (reception) to the IICA shift register 0 (IICA0) and transmits the slave address.
- <3> In the slave device if the address received matches the address (SVA0 value) of a slave device<sup>Note</sup>, that slave device sends an ACK by hardware to the master device. The ACK is detected by the master device (ACKD0 = 1) at the rising edge of the 9th clock.
- <4> The master device issues an interrupt (INTIICA0: end of address transmission) at the falling edge of the 9th clock. The slave device whose address matched the transmitted slave address sets a wait status (SCLA0 = 0) and issues an interrupt (INTIICA0: address match)<sup>Note</sup>.
- <5> The timing at which the master device sets the wait status changes to the 8th clock (WTIM0 = 0).
- <6> The slave device writes the data to transmit to the IICA0 register and releases the wait status that it set by the slave device.
- <7> The master device releases the wait status (WREL0 = 1) and starts transferring data from the slave device to the master device.

**Note** If the transmitted address does not match the address of the slave device, the slave device does not return an ACK to the master device (NACK: SDAA0 = 1). The slave device also does not issue the INTIICA0 interrupt (address match) and does not set a wait status. The master device, however, issues the INTIICA0 interrupt (end of address transmission) regardless of whether it receives an ACK or NACK.

**Remark** <1> to <19> in Figure 13-33 represent the entire procedure for communicating data using the I<sup>2</sup>C bus. Figure 13-33 (1) Start condition ~ address ~ data shows the processing from <1> to <7>, Figure 13-33 (2) Address ~ data ~ data shows the processing from <3> to <12>, and Figure 13-33 (3) Data ~ data ~ stop condition shows the processing from <8> to <19>.

**Figure 13-33. Example of Slave to Master Communication**  
**(8-Clock Wait Is Selected for Master, 9-Clock Wait Is Selected for Slave) (2/3)**

**(2) Address ~ data ~ data**



- Notes**
- For releasing wait state during reception of a master device, write “FFH” to IICA0 or set the WRELO bit.
  - Write data to IICA0, not setting the WRELO bit, in order to cancel a wait state during transmission by a slave device.

The meanings of <3> to <12> in (2) Address ~ data ~ data in Figure 13-33 are explained below.

- <3> In the slave device if the address received matches the address (SVA0 value) of a slave device<sup>Note</sup>, that slave device sends an ACK by hardware to the master device. The ACK is detected by the master device (ACKD0 = 1) at the rising edge of the 9th clock.
- <4> The master device issues an interrupt (INTIICA0: end of address transmission) at the falling edge of the 9th clock. The slave device whose address matched the transmitted slave address sets a wait status (SCLA0 = 0) and issues an interrupt (INTIICA0: address match)<sup>Note</sup>.
- <5> The master device changes the timing of the wait status to the 8th clock (WTIM0 = 0).
- <6> The slave device writes the data to transmit to the IICA shift register 0 (IICA0) and releases the wait status that it set by the slave device.
- <7> The master device releases the wait status (WREL0 = 1) and starts transferring data from the slave device to the master device.
- <8> The master device sets a wait status (SCLA0 = 0) at the falling edge of the 8th clock, and issues an interrupt (INTIICA0: end of transfer). Because of ACKE0 = 1 in the master device, the master device then sends an ACK by hardware to the slave device.
- <9> The master device reads the received data and releases the wait status (WREL0 = 1).
- <10> The ACK is detected by the slave device (ACKD0 = 1) at the rising edge of the 9th clock.
- <11> The slave device set a wait status (SCLA0 = 0) at the falling edge of the 9th clock, and the slave device issue an interrupt (INTIICA0: end of transfer).
- <12> By the slave device writing the data to transmit to the IICA0 register, the wait status set by the slave device is released. The slave device then starts transferring data to the master device.

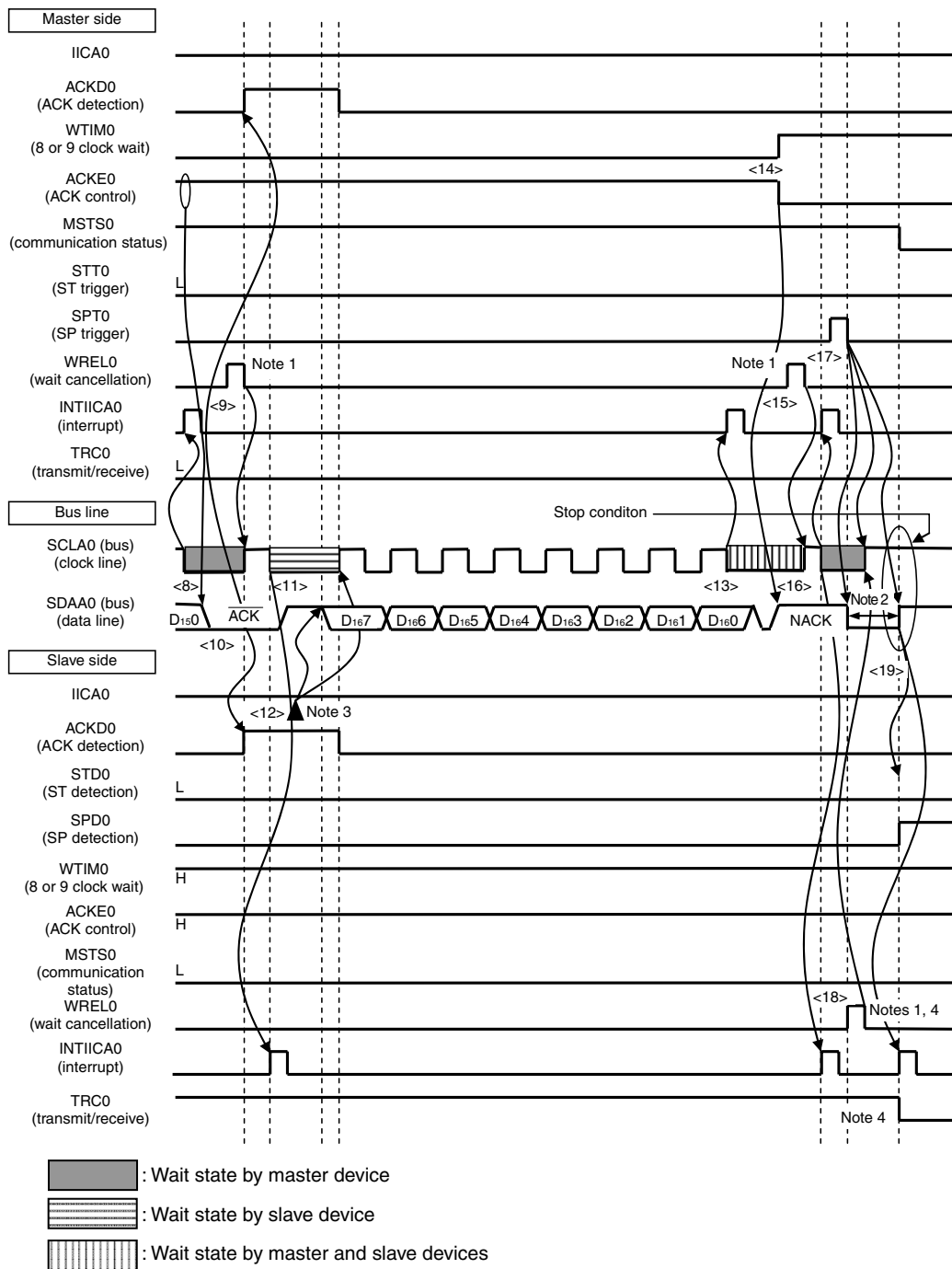
**Note** If the transmitted address does not match the address of the slave device, the slave device does not return an ACK to the master device (NACK: SDAA0 = 1). The slave device also does not issue the INTIICA0 interrupt (address match) and does not set a wait status. The master device, however, issues the INTIICA0 interrupt (end of address transmission) regardless of whether it receives an ACK or NACK.

**Remark** <1> to <19> in Figure 13-33 represent the entire procedure for communicating data using the I<sup>2</sup>C bus. Figure 13-33 (1) Start condition ~ address ~ data shows the processing from <1> to <7>, Figure 13-33 (2) Address ~ data ~ data shows the processing from <3> to <12>, and Figure 13-33 (3) Data ~ data ~ stop condition shows the processing from <8> to <19>.



**Figure 13-33. Example of Slave to Master Communication (8-Clock and 9-Clock Wait Is Selected for Master, 9-Clock Wait Is Selected for Slave) (3/3)**

**(3) Data ~ data ~ stop condition**



- Notes 1.** To cancel a wait state, write “FFH” to IICA0 or set the WREL0 bit.
- 2.** Make sure that the time between the rise of the SCLA0 pin signal and the generation of the stop condition after a stop condition has been issued is at least 4.0  $\mu$ s when specifying standard mode and at least 0.6  $\mu$ s when specifying fast mode.
- 3.** Write data to IICA0, not setting the WREL0 bit, in order to cancel a wait state during transmission by a slave device.
- 4.** If a wait state during transmission by a slave device is canceled by setting the WREL0 bit, the TRC0 bit will be cleared.

The meanings of <8> to <19> in (3) Data ~ data ~ stop condition in Figure 13-33 are explained below.

- <8> The master device sets a wait status (SCLA0 = 0) at the falling edge of the 8th clock, and issues an interrupt (INTIICA0: end of transfer). Because of ACKE0 = 0 in the master device, the master device then sends an ACK by hardware to the slave device.
- <9> The master device reads the received data and releases the wait status (WRELO = 1).
- <10> The ACK is detected by the slave device (ACKD0 = 1) at the rising edge of the 9th clock.
- <11> The slave device set a wait status (SCLA0 = 0) at the falling edge of the 9th clock, and the slave device issue an interrupt (INTIICA0: end of transfer).
- <12> By the slave device writing the data to transmit to the IICA register, the wait status set by the slave device is released. The slave device then starts transferring data to the master device.
- <13> The master device issues an interrupt (INTIICA0: end of transfer) at the falling edge of the 8th clock, and sets a wait status (SCLA0 = 0). Because ACK control (ACKE0 = 1) is performed, the bus data line is at the low level (SDAA0 = 0) at this stage.
- <14> The master device sets NACK as the response (ACKE0 = 0) and changes the timing at which it sets the wait status to the 9th clock (WTIMO = 1).
- <15> If the master device releases the wait status (WRELO = 1), the slave device detects the NACK (ACK = 0) at the rising edge of the 9th clock.
- <16> The master device and slave device set a wait status (SCLA0 = 0) at the falling edge of the 9th clock, and both the master device and slave device issue an interrupt (INTIICA0: end of transfer).
- <17> When the master device issues a stop condition (SPT0 = 1), the bus data line is cleared (SDAA0 = 0) and the master device releases the wait status. The master device then waits until the bus clock line is set (SCLA0 = 1).
- <18> The slave device acknowledges the NACK, halts transmission, and releases the wait status (WRELO = 1) to end communication. Once the slave device releases the wait status, the bus clock line is set (SCLA0 = 1).
- <19> Once the master device recognizes that the bus clock line is set (SCLA0 = 1) and after the stop condition setup time has elapsed, the master device sets the bus data line (SDAA0 = 1) and issues a stop condition (i.e. SCLA0 =1 changes SDAA0 from 0 to 1). The slave device detects the generated stop condition and slave device issue an interrupt (INTIICA0: stop condition).

**Remark** <1> to <19> in Figure 13-33 represent the entire procedure for communicating data using the I<sup>2</sup>C bus. Figure 13-33 (1) Start condition ~ address ~ data shows the processing from <1> to <7>, Figure 13-33 (2) Address ~ data ~ data shows the processing from <3> to <12>, and Figure 13-33 (3) Data ~ data ~ stop condition shows the processing from <8> to <19>.

## CHAPTER 14 MULTIPLIER AND DIVIDER/MULTIPLY-ACCUMULATOR

### 14.1 Functions of Multiplier and Divider/Multiply-Accumulator

The multiplier and divider/multiply-accumulator has the following functions.

- $16 \text{ bits} \times 16 \text{ bits} = 32 \text{ bits}$  (Unsigned)
- $16 \text{ bits} \times 16 \text{ bits} = 32 \text{ bits}$  (Signed)
- $16 \text{ bits} \times 16 \text{ bits} + 32 \text{ bits} = 32 \text{ bits}$  (Unsigned)
- $16 \text{ bits} \times 16 \text{ bits} + 32 \text{ bits} = 32 \text{ bits}$  (Signed)
- $32 \text{ bits} \div 32 \text{ bits} = 32 \text{ bits}$ , 32-bits remainder (Unsigned)

### 14.2 Configuration of Multiplier and Divider/Multiply-Accumulator

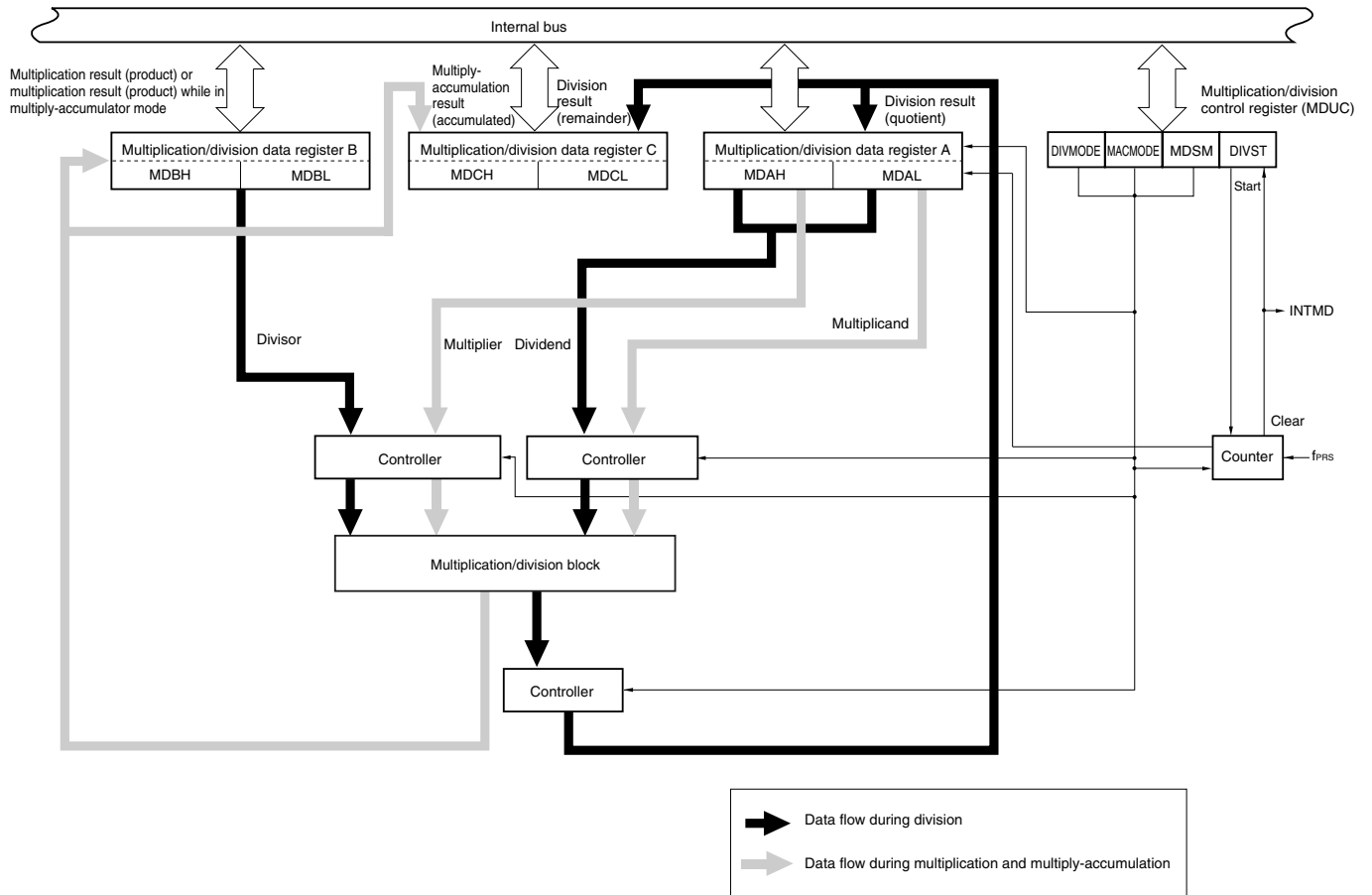
The multiplier and divider/multiply-accumulator consists of the following hardware.

**Table 14-1. Configuration of Multiplier and Divider/Multiply-Accumulator**

Item	Configuration
Registers	Multiplication/division data register A (L) (MDAL) Multiplication/division data register A (H) (MDAH) Multiplication/division data register B (L) (MDBL) Multiplication/division data register B (H) (MDBH) Multiplication/division data register C (L) (MDCL) Multiplication/division data register C (H) (MDCH)
Control register	Multiplication/division control register (MDUC)

Figure 14-1 shows a block diagram of the multiplier and divider/multiply-accumulator.

Figure 14-1. Block Diagram of Multiplier and Divider/Multiply-Accumulator



**(1) Multiplication/division data register A (MDAH, MDAL)**

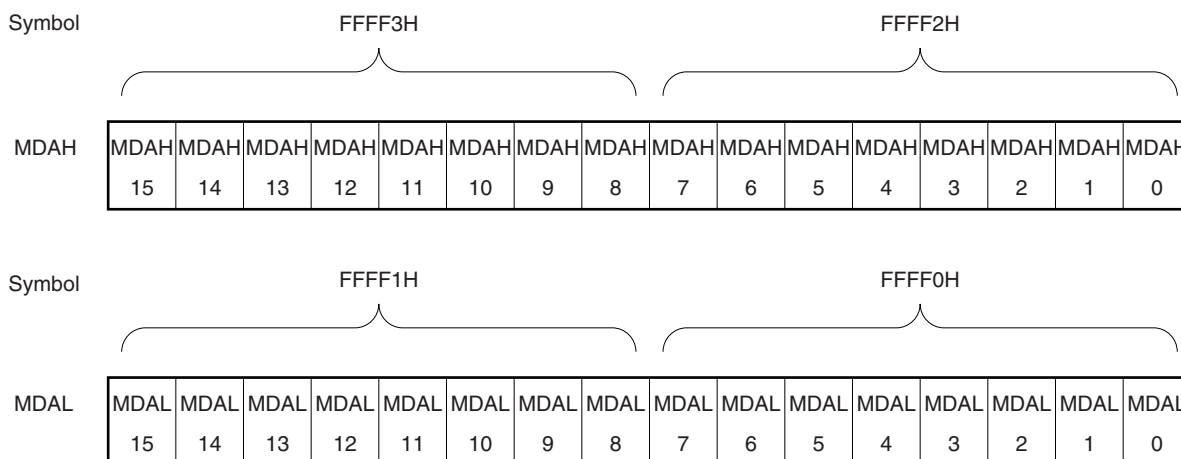
The MDAH and MDAL registers set the values that are used for a multiplication or division operation and store the operation result. They set the multiplier and multiplicand data in the multiplication mode or multiply-accumulator mode, and set the dividend data in the division mode. Furthermore, the operation result (quotient) is stored in the MDAH and MDAL registers in the division mode.

The MDAH and MDAL registers can be set by a 16-bit manipulation instruction.

Reset signal generation clears these registers to 0000H.

**Figure 14-2. Format of Multiplication/Division Data Register A (MDAH, MDAL)**

Address: FFFF0H, FFFF1H, FFFF2H, FFFF3H After reset: 0000H, 0000H R/W



- Cautions**
1. Do not rewrite the MDAH and MDAL registers values during division operation processing (when the multiplication/division control register (MDUC) value is 81H or C1H). The operation will be executed in this case, but the operation result will be an undefined value.
  2. The MDAH and MDAL registers values read during division operation processing (when the MDUC register value is 81H or C1H) will not be guaranteed.
  3. The data is in the two's complement format in either the multiplication mode (signed) or multiply-accumulator mode (signed).

The following table shows the functions of the MDAH and MDAL registers during operation execution.

**Table 14-2. Functions of MDAH and MDAL Registers During Operation Execution**

Operation Mode	Setting	Operation Result
Multiplication mode (unsigned) Multiply-accumulator mode (unsigned)	MDAH: Multiplier (unsigned) MDAL: Multiplicand (unsigned)	–
Multiplication mode (signed) Multiply-accumulator mode (signed)	MDAH: Multiplier (signed) MDAL: Multiplicand (signed)	–
Division mode	MDAH: Dividend (higher 16 bits) MDAL: Dividend (lower 16 bits)	MDAH: Division result (quotient) Higher 16 bits MDAL: Division result (quotient) Lower 16 bits

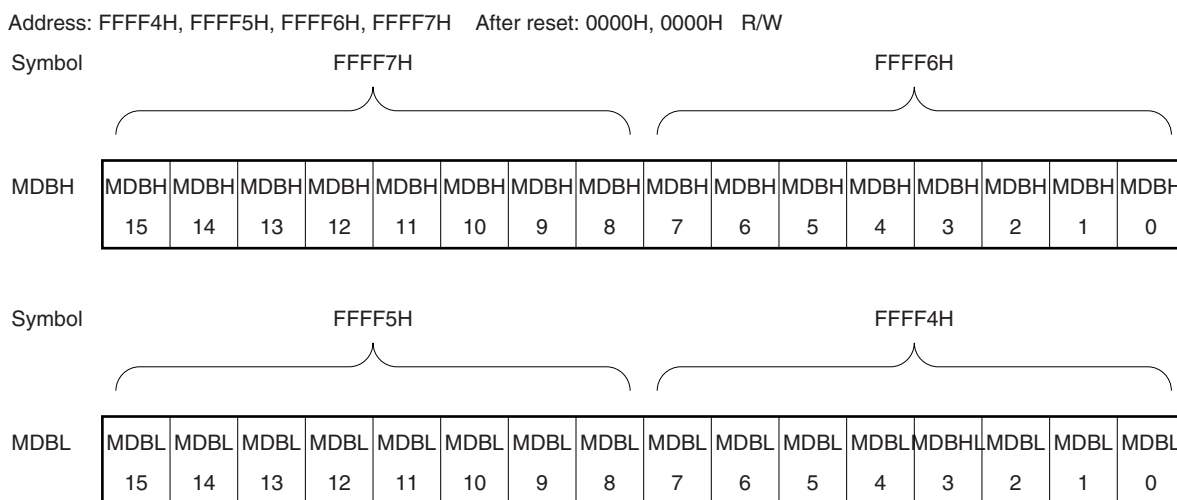
**(2) Multiplication/division data register B (MDBL, MDBH)**

The MDBH and MDBL registers set the values that are used for multiplication or division operation and store the operation result. They store the operation result (product) in the multiplication mode and multiply-accumulator mode, and set the divisor data in the division mode.

The MDBH and MDBL registers can be set by a 16-bit manipulation instruction.

Reset signal generation clears these registers to 0000H.

**Figure 14-3. Format of Multiplication/Division Data Register B (MDBH, MDBL)**



- Cautions**
1. Do not rewrite the MDBH and MDBL registers values during division operation processing (when the multiplication/division control register (MDUC) value is 81H or C1H) or multiply-accumulation operation processing (when the MDUC register value is 41H or 49H). The operation result will be an undefined value.
  2. Do not set the MDBH and MDBL registers to 0000H in the division mode. If they are set, the operation result will be an undefined value.
  3. The data is in the two's complement format in either the multiplication mode (signed) or multiply-accumulator mode (signed).

The following table shows the functions of the MDBH and MDBL registers during operation execution.

**Table 14-3. Functions of MDBH and MDBL Registers During Operation Execution**

Operation Mode	Setting	Operation Result
Multiplication mode (unsigned) Multiply-accumulator mode (unsigned)	-	MDBH: Multiplication result (product) (unsigned) Higher 16 bits MDBL: Multiplication result (product) (unsigned) Lower 16 bits
Multiplication mode (signed) Multiply-accumulator mode (signed)	-	MDBH: Multiplication result (product) (signed) Higher 16 bits MDBL: Multiplication result (product) (signed) Lower 16 bits
Division mode	MDBH: Divisor (higher 16 bits) MDBL: Divisor (lower 16 bits)	-

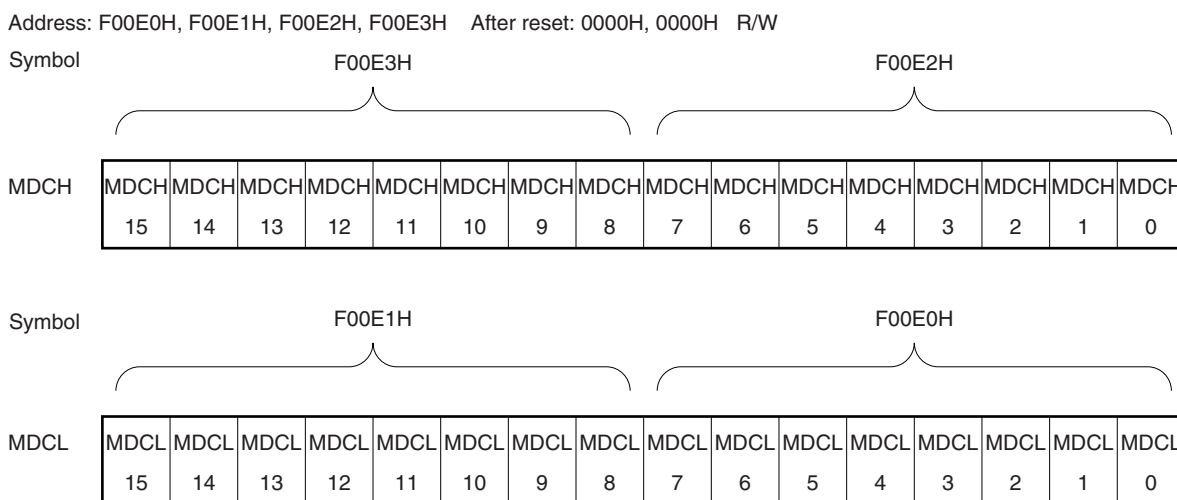
**(3) Multiplication/division data register C (MDCL, MDCH)**

The MDCH and MDCL registers are used to store the accumulated result while in the multiply-accumulator mode or the remainder of the operation result while in the division mode. These registers are not used while in the multiplication mode.

The MDCH and MDCL registers can be set by a 16-bit manipulation instruction.

Reset signal generation clears these registers to 0000H.

**Figure 14-4. Format of Multiplication/Division Data Register C (MDCH, MDCL)**



- Cautions**
1. The MDCH and MDCL registers values read during division operation processing (when the multiplication/division control register (MDUC) value is 81H or C1H) will not be guaranteed.
  2. During multiply-accumulator processing (when the MDUC register value is 41H or 49H), do not use software to rewrite the values of the MDCH and MDCL registers. If this is done, the operation result will be undefined.
  3. The data is in the two's complement format in the multiply-accumulator mode (signed).

**Table 14-4. Functions of MDCH and MDCL Registers During Operation Execution**

Operation Mode	Setting	Operation Result
Multiplication mode (unsigned or signed)	–	–
Multiply-accumulator mode (unsigned)	MDCH: Initial accumulated value (unsigned) (higher 16 bits) MDCL: Initial accumulated value (unsigned) (lower 16 bits)	MDCH: accumulated value (unsigned) (higher 16 bits) MDCL: accumulated value (unsigned) (lower 16 bits)
Multiply-accumulator mode (signed)	MDCH: Initial accumulated value (signed) (higher 16 bits) MDCL: Initial accumulated value (signed) (lower 16 bits)	MDCH: accumulated value (signed) (higher 16 bits) MDCL: accumulated value (signed) (lower 16 bits)
Division mode	–	MDCH: Remainder (higher 16 bits) MDCL: Remainder (lower 16 bits)

The register configuration differs between when multiplication is executed and when division is executed, as follows.

- Register configuration during multiplication

<Multiplier A>      <Multiplier B>                      <Product>

$$\text{MDAL (bits 15 to 0)} \times \text{MDAH (bits 15 to 0)} = [\text{MDBH (bits 15 to 0), MDBL (bits 15 to 0)}]$$

- Register configuration during multiply-accumulation

<Multiplier A>      <Multiplier B>      < accumulated value >              < accumulated result >

$$\text{MDAL (bits 15 to 0)} \times \text{MDAH (bits 15 to 0)} + \text{MDC (bits 31 to 0)} = [\text{MDCH (bits 15 to 0), MDCL (bits 15 to 0)}]$$

(The multiplication result is stored in the MDBH (bits 15 to 0) and MDBL (bits 15 to 0).)

- Register configuration during division

<Dividend>    <Divisor>

$$[\text{MDAH (bits 15 to 0), MDAL (bits 15 to 0)}] \div [\text{MDBH (bits 15 to 0), MDBL (bits 15 to 0)}] =$$

<Quotient>    <Remainder>

$$[\text{MDAH (bits 15 to 0), MDAL (bits 15 to 0)}] \dots [\text{MDCH (bits 15 to 0), MDCL (bits 15 to 0)}]$$



### 14.3 Register Controlling Multiplier and Divider/Multiply-Accumulator

The multiplier and divider/multiply-accumulator is controlled by using the multiplication/division control register (MDUC).

#### (1) Multiplication/division control register (MDUC)

The MDUC register is an 8-bit register that controls the operation of the multiplier and divider/multiply-accumulator. The MDUC register can be set by a 1-bit or 8-bit memory manipulation instruction. Reset signal generation clears this register to 00H.

**Figure 14-5. Format of Multiplication/Division Control Register (MDUC)**

Address: F00E8H After reset: 00H R/W

Symbol	<7>	<6>	5	4	<3>	<2>	<1>	<0>
MDUC	DIVMODE	MACMODE	0	0	MDSM	MDCOF	MACSF	DIVST

DIVMODE	MACMODE	MDSM	Operation mode selection
0	0	0	Multiplication mode (unsigned) (default)
0	0	1	Multiplication mode (signed)
0	1	0	Multiply-accumulator mode (unsigned)
0	1	1	Multiply-accumulator mode (signed)
1	0	0	Division mode (unsigned), generation of a division completion interrupt (INTMD)
1	1	0	Division mode (unsigned), not generation of a division completion interrupt (INTMD)

MACOF	Overflow flag of multiply-accumulation result (accumulated value)
0	No overflow
1	With over flow

<Set condition>

- For the multiply-accumulator mode (unsigned)  
The bit is set when the accumulated value goes outside the range from 00000000h to FFFFFFFFh.
- For the multiply-accumulator mode (signed)  
The bit is set when the result of adding a positive product to a positive accumulated value exceeds 7FFFFFFFh and is negative, or when the result of adding a negative product to a negative accumulated value exceeds 80000000h and is positive.

MACSF	Sign flag of multiply-accumulation result (accumulated value)
0	The accumulated value is positive.
1	The accumulated value is negative.

Multiply-accumulator mode (unsigned): The bit is always 0.  
 Multiply-accumulator mode (signed): The bit indicates the sign bit of the accumulated value.

DIVST <sup>Note</sup>	Division operation start/stop
0	Division operation processing complete
1	Starts division operation/division operation processing in progress

**Note** The DIVST bit can only be set (1) in the division mode. In the division mode, division operation is started by setting (1) the DIVST bit. The DIVST bit is automatically cleared (0) when the operation ends. In the multiplication mode, operation is automatically started by setting the multiplier and multiplicand to multiplication/division data register A (MDAH, MDAL), respectively.

- Cautions**
1. Do not rewrite the DIVMODE, MDSM bits during operation processing (while the DIVST bit is 1). If it is rewritten, the operation result will be an undefined value.
  2. The DIVST bit cannot be cleared (0) by using software during division operation processing (while the DIVST bit is 1).

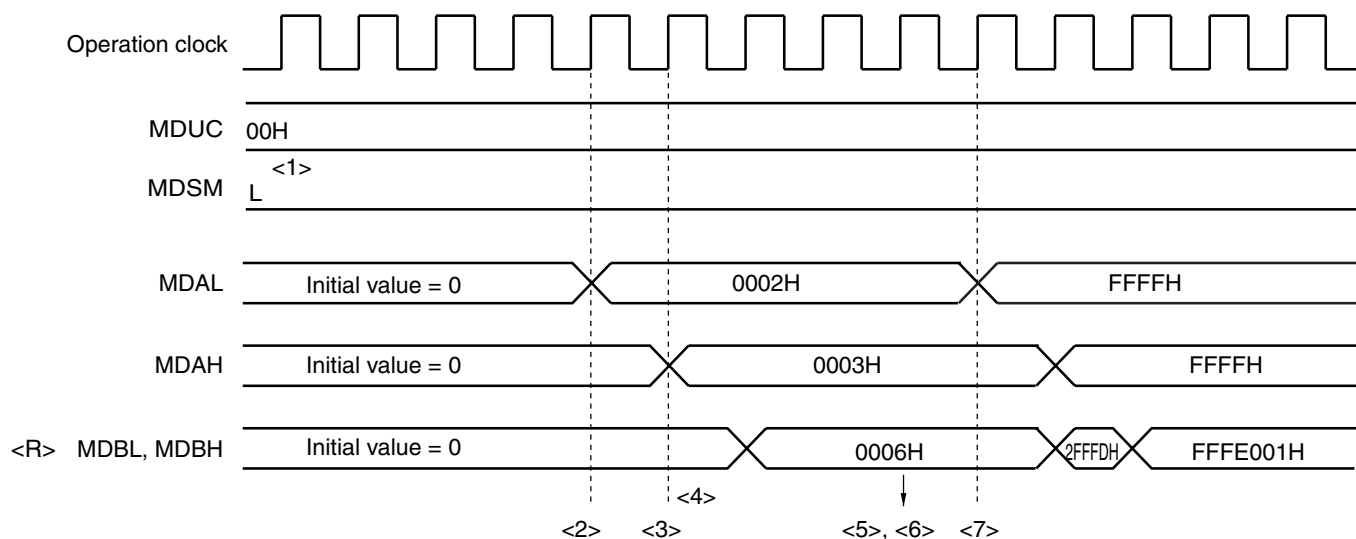
### 14.4 Operations of Multiplier and Divider/Multiply-Accumulator

#### 14.4.1 Multiplication (unsigned) operation

- Initial setting
  - <1> Set the multiplication/division control register (MDUC) to 00H.
  - <2> Set the multiplicand to multiplication/division data register A (L) (MDAL).
  - <3> Set the multiplier to multiplication/division data register A (H) (MDAH).  
(There is no preference in the order of executing steps <2> and <3>. Multiplication operation is automatically started when the multiplier and multiplicand are set to the MDAH and MDAL registers, respectively.)
- During operation processing
  - <4> Wait for at least one clock. The operation will end when one clock has been issued.
- Operation end
  - <5> Read the product (lower 16 bits) from multiplication/division data register B (L) (MDBL).
  - <6> Read the product (higher 16 bits) from multiplication/division data register B (H) (MDBH).  
(There is no preference in the order of executing steps <5> and <6>.)
- Next operation
  - <7> To execute multiplication (unsigned) operation next, start from the “Initial setting” for multiplication (unsigned) operation.
  - <8> The next time multiplication (signed), multiply-accumulation (signed or unsigned), or division is performed, start with the initial settings of each step.

**Remark** Steps <1> to <7> correspond to <1> to <7> in Figure 14-6.

**Figure 14-6. Timing Diagram of Multiplication (Unsigned) Operation (2 × 3 = 6)**



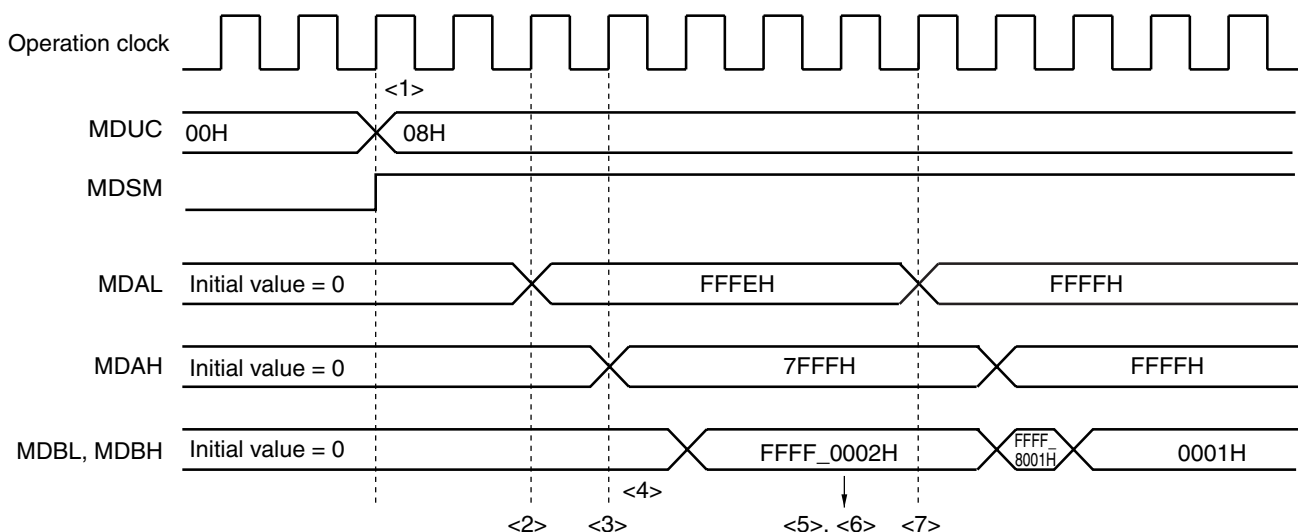
14.4.2 Multiplication (signed) operation

- Initial setting
  - <1> Set the multiplication/division control register (MDUC) to 08H.
  - <2> Set the multiplicand to multiplication/division data register A (L) (MDAL).
  - <3> Set the multiplier to multiplication/division data register A (H) (MDAH).  
(There is no preference in the order of executing steps <2> and <3>. Multiplication operation is automatically started when the multiplier and multiplicand are set to the MDAH and MDAL registers, respectively.)
- During operation processing
  - <4> Wait for at least one clock. The operation will end when one clock has been issued.
- Operation end
  - <5> Read the product (lower 16 bits) from multiplication/division data register B (L) (MDBL).
  - <6> Read the product (higher 16 bits) from multiplication/division data register B (H) (MDBH).  
(There is no preference in the order of executing steps <5> and <6>.)
- Next operation
  - <7> To execute multiplication (signed) operation next, start from the "Initial setting" for multiplication (signed) operation.
  - <8> The next time multiplication (unsigned), multiply-accumulation (signed or unsigned), or division is performed, start with the initial settings of each step.

**Caution** The data is in the two's complement format in multiplication mode (signed).

**Remark** Steps <1> to <7> correspond to <1> to <7> in Figure 14-7.

Figure 14-7. Timing Diagram of Multiplication (Signed) Operation ( $-2 \times 32767 = -65534$ )



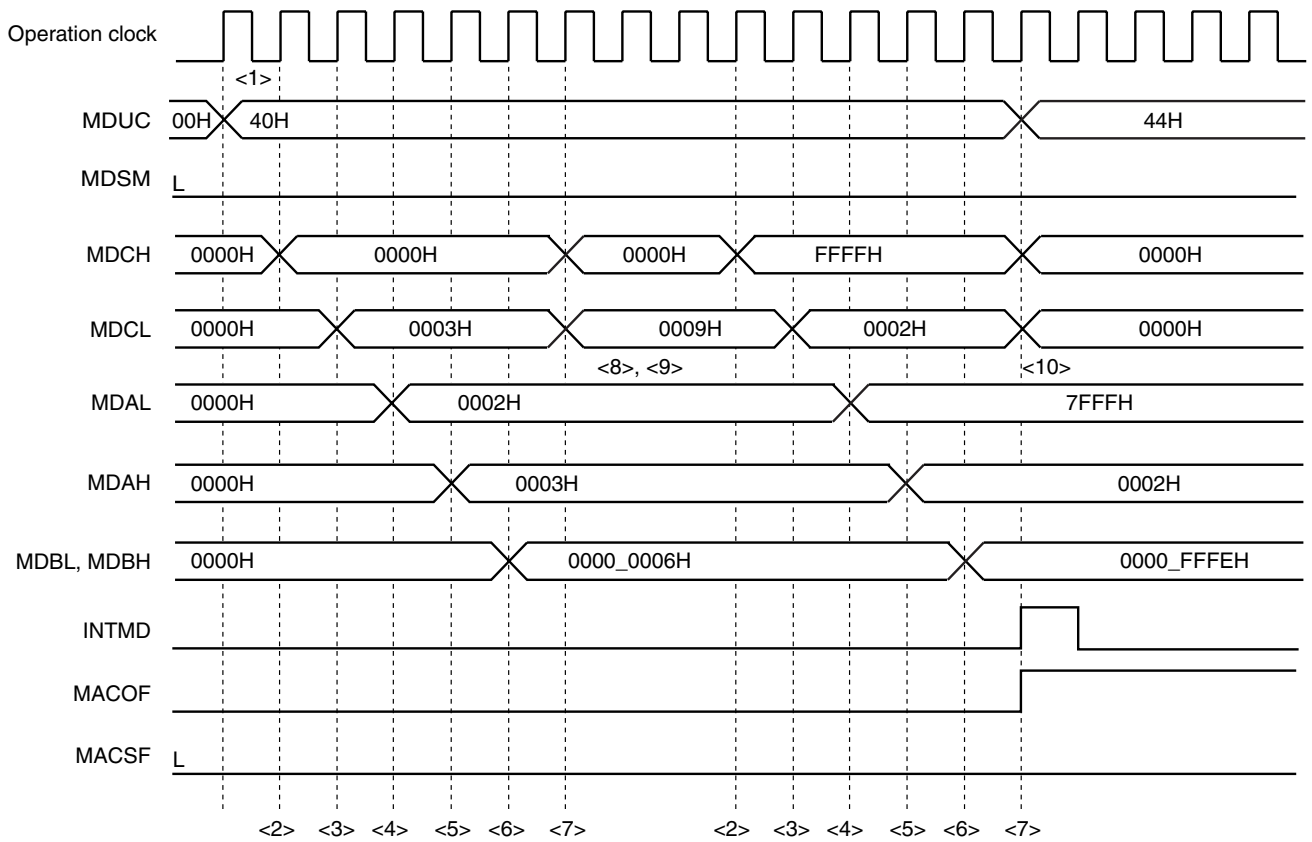
### 14.4.3 Multiply-accumulation (unsigned) operation

- Initial setting
  - <1> Set the multiplication/division control register (MDUC) to 40H.
  - <2> Set the initial accumulated value of higher 16 bits to multiplication/division data register C (L) (MDCL).
  - <3> Set the initial accumulated value of lower 16 bits to multiplication/division data register C (H) (MDCH).
  - <4> Set the multiplicand to multiplication/division data register A (L) (MDAL).
  - <5> Set the multiplier to multiplication/division data register A (H) (MDAH).
- <R> (There is no preference in the order of executing steps <2>, <3>, and <4>. Multiplication operation is automatically started when the multiplier is set to the MDAH register, respectively.)
- During operation processing
  - <6> The multiplication operation finishes in one clock cycle.  
(The multiplication result is stored in multiplication/division data register B (L) (MDBL) and multiplication/division data register B (H) (MDBH).)
  - <7> After <6>, the multiply-accumulation operation finishes in one additional clock cycle. (There is a wait of at least two clock cycles after specifying the initial settings is finished (<5>).)
- Operation end
  - <8> Read the accumulated value (lower 16 bits) from the MDCL register.
  - <9> Read the accumulated value (higher 16 bits) from the MDCH register.  
(There is no preference in the order of executing steps <8> and <9>.)
- <R> (<10> If the result of the multiply-accumulation operation causes an overflow, the MACOF bit is set to 1, INTMD signal is occurred.)
- Next operation
  - <11> To execute multiply-accumulation (unsigned) operation next, start from the "Initial setting" for multiply-accumulation (unsigned) operation.
  - <12> The next time multiplication (signed or unsigned), multiply-accumulation (signed), or division is performed, start with the initial settings of each step.

**Remark** Steps <1> to <10> correspond to <1> to <10> in Figure 14-8.

**Figure 14-8. Timing Diagram of Multiply-Accumulation (Unsigned) Operation**  
 $(2 \times 3 + 3 = 9 \rightarrow 32767 \times 2 + 4294901762 = 0 \text{ (over flow generated)})$

<R>



#### 14.4.4 Multiply-accumulation (signed) operation

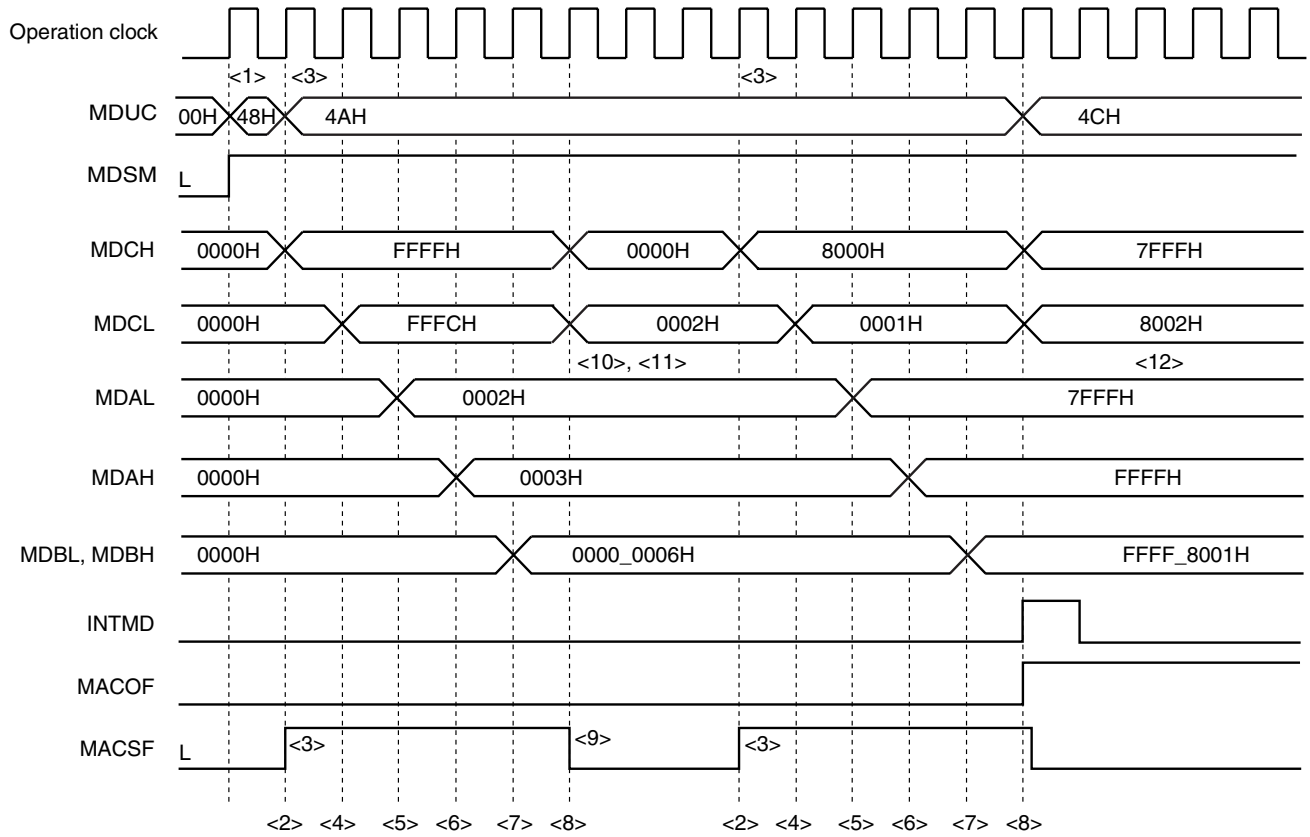
- Initial setting
  - <1> Set the multiplication/division control register (MDUC) to 48H.
  - <2> Set the initial accumulated value of higher 16 bits to multiplication/division data register C (H) (MDCH).  
(<3> If the accumulated value in the MDCH register is negative, the MACSF bit is set to 1.)
  - <4> Set the initial accumulated value of lower 16 bits to multiplication/division data register C (L) (MDCL).
  - <5> Set the multiplicand to multiplication/division data register A (L) (MDAL).
  - <6> Set the multiplier to multiplication/division data register A (H) (MDAH).
- <R> (There is no preference in the order of executing steps <2>, <4>, and <5>. Multiplication operation is automatically started when the multiplier is set to the MDAH register, respectively.)
- During operation processing
  - <7> The multiplication operation finishes in one clock cycle.  
(The multiplication result is stored in multiplication/division data register B (L) (MDBL) and multiplication/division data register B (H) (MDBH).)
  - <8> After <7>, the multiply-accumulation operation finishes in one additional clock cycle. (There is a wait of at least two clock cycles after specifying the initial settings is finished (<6>).)
- Operation end
  - <9> If the accumulated value stored in the MDCL and MDCH registers is positive, the MACSF bit is cleared to 0.
  - <10> Read the accumulated value (lower 16 bits) from the MDCL register.
  - <11> Read the accumulated value (higher 16 bits) from the MDCH register.  
(There is no preference in the order of executing steps <10> and <11>.)
  - <12> If the result of the multiply-accumulation operation causes an overflow, the MACOF bit is set to 1, INTMD signal is occurred.)
- Next operation
  - <13> To execute multiply-accumulation (signed) operation next, start from the “Initial setting” for multiply-accumulation (signed) operation.
  - <14> The next time multiplication (signed or unsigned), multiply-accumulation (unsigned), or division is performed, start with the initial settings of each step.

**Caution** The data is in the two's complement format in multiply-accumulation (signed) operation.

**Remark** Steps <1> to <12> correspond to <1> to <12> in Figure 14-9.

<R>

**Figure 14-9. Timing Diagram of Multiply-Accumulation (signed) Operation**  
 $(2 \times 3 + (-4) = 2 \rightarrow 32767 \times (-1) + (-2147483647) = -2147450882$  (overflow occurs.))



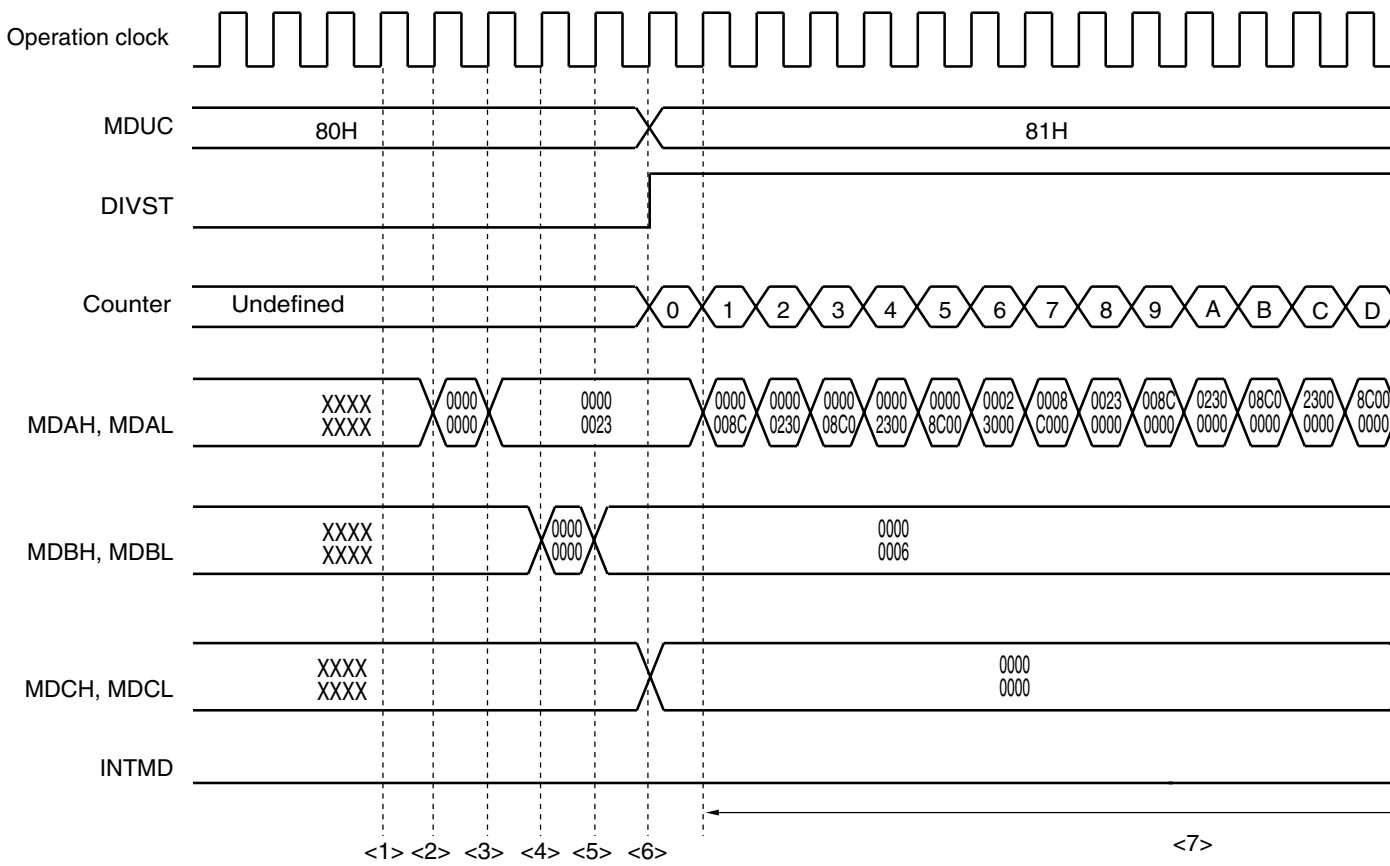


#### 14.4.5 Division operation

- Initial setting
  - <1> Set the multiplication/division control register (MDUC) to 80H.
  - <2> Set the dividend (higher 16 bits) to multiplication/division data register A (H) (MDAH).
  - <3> Set the dividend (lower 16 bits) to multiplication/division data register A (L) (MDAL).
  - <4> Set the divisor (higher 16 bits) to multiplication/division data register B (H) (MDBH).
  - <5> Set the divisor (lower 16 bits) to multiplication/division data register B (L) (MDBL).
  - <6> Set bit 0 (DIVST) of the MDUC register to 1.  
(There is no preference in the order of executing steps <2> to <5>.)
- During operation processing
  - <7> The operation will end when one of the following processing is completed.
    - A wait of at least 16 clocks (The operation will end when 16 clocks have been issued.)
    - A check whether the DIVST bit has been cleared
    - Generation of a division completion interrupt (INTMD)  
(The read values of the MDBL, MDBH, MDCL, and MDCH registers during operation processing are not guaranteed.)
- Operation end
  - <8> The DIVST bit is cleared (0) and an interrupt request signal (INTMD) is generated (end of operation).
  - <9> Read the quotient (lower 16 bits) from the MDAL register.
  - <10> Read the quotient (higher 16 bits) from the MDAH register.
  - <11> Read the remainder (lower 16 bits) from multiplication/division data register C (L) (MDCL).
  - <12> Read the remainder (higher 16 bits) from multiplication/division data register C (H) (MDCH).  
(There is no preference in the order of executing steps <9> to <12>.)
- Next operation
  - <13> To execute division operation next, start from the “Initial setting” for Division operation.
  - <14> The next time multiplication (signed or unsigned) or multiply-accumulation (signed or unsigned) is performed, start with the initial settings of each step.

**Remark** Steps <1> to <12> correspond to <1> to <12> in Figure 14-10.

Figure 14-10. Timing Diagram of Division Operation (Example:  $35 \div 6 = 5$ , Remainder 5)



## CHAPTER 15 DMA CONTROLLER

The RL78/G13 has an internal DMA (Direct Memory Access) controller.

Data can be automatically transferred between the peripheral hardware supporting DMA, SFRs, and internal RAM without via CPU.

As a result, the normal internal operation of the CPU and data transfer can be executed in parallel with transfer between the SFR and internal RAM, and therefore, a large capacity of data can be processed. In addition, real-time control using communication, timer, and A/D can also be realized.

### 15.1 Functions of DMA Controller

- Number of DMA channels: 2 channels (20, 24, 25, 30, 32, 36, 40, 44, 48, 52, or 64-pin products)  
4 channels (80, 100, or 128-pin products)
- Transfer unit: 8 or 16 bits
- Maximum transfer unit: 1024 times
- Transfer type: 2-cycle transfer (One transfer is processed in 2 clocks and the CPU stops during that processing.)
- Transfer mode: Single-transfer mode
- Transfer request: Selectable from the following peripheral hardware interrupts
  - A/D converter
  - Serial interface  
(CSI00, CSI01, CSI10, CSI11, CSI20, CSI21, CSI30, CSI31, UART0 to UART3)
  - Timer (channel 0, 1, 2, 3, 10, 11, 12, or 13)
- Transfer target: Between SFR and internal RAM

Here are examples of functions using DMA.

- Successive transfer of serial interface
- Batch transfer of analog data
- Capturing A/D conversion result at fixed interval
- Capturing port value at fixed interval

### 15.2 Configuration of DMA Controller

The DMA controller includes the following hardware.

**Table 15-1. Configuration of DMA Controller**

Item	Configuration
Address registers	<ul style="list-style-type: none"> <li>• DMA SFR address registers 0 to 3 (DSA0 to DSA3)</li> <li>• DMA RAM address registers 0 to 3 (DRA0 to DRA3)</li> </ul>
Count register	<ul style="list-style-type: none"> <li>• DMA byte count registers 0 to 3 (DBC0 to DBC3)</li> </ul>
Control registers	<ul style="list-style-type: none"> <li>• DMA mode control registers 0 to 3 (DMC0 to DMC3)</li> <li>• DMA operation control register 0 to 3 (DRC0 to DRC3)</li> </ul>

**(1) DMA SFR address register n (DSAn)**

This is an 8-bit register that is used to set an SFR address that is the transfer source or destination of DMA channel n.

Set the lower 8 bits of the SFR addresses FFF00H to FFFFFH.

This register is not automatically incremented but fixed to a specific value.

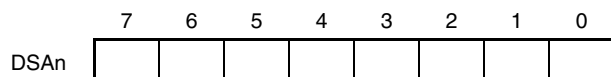
In the 16-bit transfer mode, the least significant bit is ignored and is treated as an even address.

The DSAn register can be read or written in 8-bit units. However, it cannot be written during DMA transfer.

Reset signal generation clears this register to 00H.

**Figure 15-1. Format of DMA SFR Address Register n (DSAn)**

Address: FFFB0H (DSA0), FFFB1H (DSA1), F0200H (DSA2), F0201H (DSA3) After reset: 00H R/W



**Remark** n: DMA channel number (n = 0 to 3)

**(2) DMA RAM address register n (DRAn)**

This is a 16-bit register that is used to set a RAM address that is the transfer source or destination of DMA channel n.

Addresses of the internal RAM area other than the general-purpose registers (see table 15-2) can be set to this register.

Set the lower 16 bits of the RAM address.

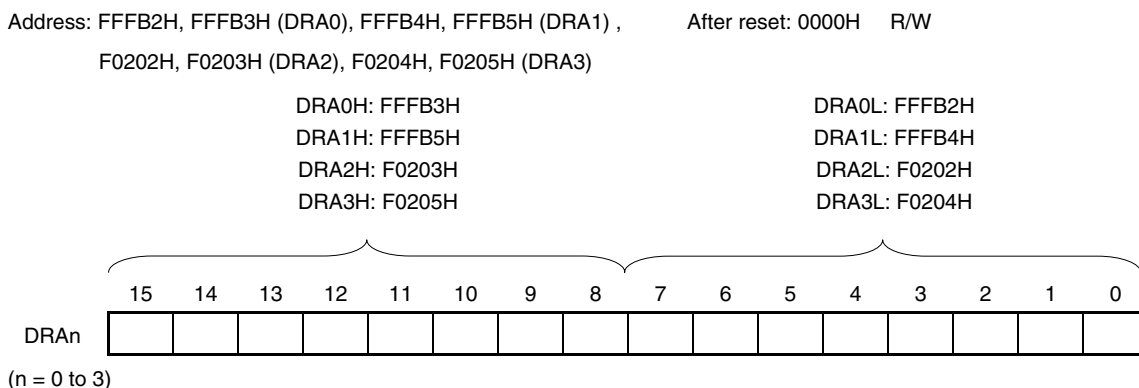
This register is automatically incremented when DMA transfer has been started. It is incremented by +1 in the 8-bit transfer mode and by +2 in the 16-bit transfer mode. DMA transfer is started from the address set to this DRAn register. When the data of the last address has been transferred, the DRAn register stops with the value of the last address +1 in the 8-bit transfer mode, and the last address +2 in the 16-bit transfer mode.

In the 16-bit transfer mode, the least significant bit is ignored and is treated as an even address.

The DRAn register can be read or written in 8-bit or 16-bit units. However, it cannot be written during DMA transfer.

Reset signal generation clears this register to 0000H.

**Figure 15-2. Format of DMA RAM Address Register n (DRAn)**



<R>

**Table 15-2 Internal RAM Area other than the General-purpose Registers**

Part Number	Internal RAM Area other than the General-purpose Registers
R5F100xA, R5F101xA (x = 6 to 8, A to C, E to G), R5F100xC, R5F101xC (x = 6 to 8, A to C, E to G, J, L)	FF700H to FFEDFH
R5F100xD, R5F101xD (x = 6 to 8, A to C, E to G, J, L)	FF300H to FFEDFH
R5F100xE, R5F101xE (x = 6 to 8, A to C, E to G, J, L)	FEF00H to FFEDFH
R5F100xF, R5F101xF (x = A to C, E to G, J, L, M, P)	FD00H to FFEDFH
R5F100xG, R5F101xG (x = A to C, E to G, J, L, M, P)	FCF00H to FFEDFH
R5F100xH, R5F101xH (x = E to G, J, L, M, P, S)	FBF00H to FFEDFH
R5F100xJ, R5F101xJ (x = F, G, J, L, M, P, S)	FAF00H to FFEDFH
R5F100xK, R5F101xK (x = F, G, J, L, M, P, S)	F9F00H to FFEDFH
R5F100xL, R5F101xL (x = F, G, J, L, M, P, S)	F7F00H to FFEDFH

**Remark** n: DMA channel number (n = 0 to 3)

**(3) DMA byte count register n (DBCn)**

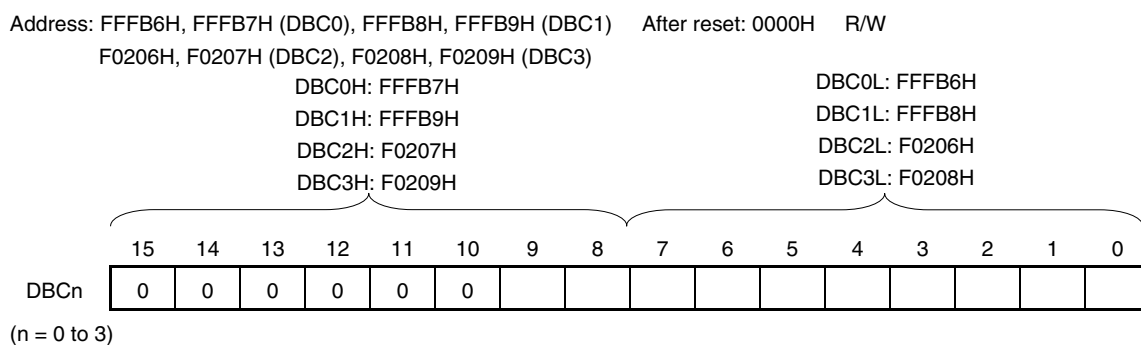
This is a 10-bit register that is used to set the number of times DMA channel n executes transfer. Be sure to set the number of times of transfer to this DBCn register before executing DMA transfer (up to 1024 times).

Each time DMA transfer has been executed, this register is automatically decremented. By reading this DBCn register during DMA transfer, the remaining number of times of transfer can be learned.

The DBCn register can be read or written in 8-bit or 16-bit units. However, it cannot be written during DMA transfer.

Reset signal generation clears this register to 0000H.

**Figure 15-3. Format of DMA Byte Count Register n (DBCn)**



DBCn[9:0]	Number of Times of Transfer (When DBCn is Written)	Remaining Number of Times of Transfer (When DBCn is Read)
000H	1024	Completion of transfer or waiting for 1024 times of DMA transfer
001H	1	Waiting for remaining one time of DMA transfer
002H	2	Waiting for remaining two times of DMA transfer
003H	3	Waiting for remaining three times of DMA transfer
•	•	•
•	•	•
•	•	•
3FEH	1022	Waiting for remaining 1022 times of DMA transfer
3FFH	1023	Waiting for remaining 1023 times of DMA transfer

- Cautions**
1. Be sure to clear bits 15 to 10 to “0”.
  2. If the general-purpose register is specified or the internal RAM space is exceeded as a result of continuous transfer, the general-purpose register or SFR space are written or read, resulting in loss of data in these spaces. Be sure to set the number of times of transfer that is within the internal RAM space.

**Remark** n: DMA channel number (n = 0 to 3)

### 15.3 Registers Controlling DMA Controller

DMA controller is controlled by the following registers.

- DMA mode control register n (DMCn)
- DMA operation control register n (DRCn)

**Remark** n: DMA channel number (n = 0 to 3)

**(1) DMA mode control register n (DMCn)**

The DMCn register is a register that is used to set a transfer mode of DMA channel n. It is used to select a transfer direction, data size, setting of pending, and start source. Bit 7 (STGn) is a software trigger that starts DMA.

Rewriting bits 6, 5, and 3 to 0 of the DMCn register is prohibited during operation (when DSTn = 1).

The DMCn register can be set by a 1-bit or 8-bit memory manipulation instruction.

Reset signal generation clears this register to 00H.

**Figure 15-4. Format of DMA Mode Control Register n (DMCn) (1/3)**

Address: FFFBAH (DMC0), FFFBBH (DMC1), F020AH (DMC2), F020BH (DMC3) After reset: 00H R/W

Symbol	<7>	<6>	<5>	<4>	3	2	1	0
DMCn	STGn	DRSn	DSn	DWAITn	IFCn3	IFCn2	IFCn1	IFCn0

STGn <sup>Note 1</sup>	DMA transfer start software trigger
0	No trigger operation
1	DMA transfer is started when DMA operation is enabled (DENn = 1).
DMA transfer is performed once by writing 1 to the STGn bit when DMA operation is enabled (DENn = 1). When this bit is read, 0 is always read.	

DRSn	Selection of DMA transfer direction
0	SFR to internal RAM
1	Internal RAM to SFR

DSn	Specification of transfer data size for DMA transfer
0	8 bits
1	16 bits

DWAITn <sup>Note 2</sup>	Pending of DMA transfer
0	Executes DMA transfer upon DMA start request (not held pending).
1	Holds DMA start request pending if any.
DMA transfer that has been held pending can be started by clearing the value of the DWAITn bit to 0. It takes 2 clocks to actually hold DMA transfer pending when the value of the DWAITn bit is set to 1.	

- Notes**
1. The software trigger (STGn) can be used regardless of the IFCn0 to IFCn3 bits values.
  2. When DMA transfer is held pending while using two or more DMA channels, be sure to hold the DMA transfer pending for all channels (by setting the DWAIT0, DWAIT1, DWAIT2, and DWAIT3 bits to 1).

**Remark** n: DMA channel number (n = 0 to 3)



Figure 15-4. Format of DMA Mode Control Register n (DMCn) (2/3)

Address: FFFBAH (DMC0), FFFBBH (DMC1) After reset: 00H R/W

Symbol	<7>	<6>	<5>	<4>	3	2	1	0
DMCn	STGn	DRSn	DSn	DWAITn	IFCn3	IFCn2	IFCn1	IFCn0

(When n = 0 or 1)

IFCn 3	IFCn 2	IFCn 1	IFCn 0	Selection of DMA start source <sup>Note</sup>	
				Trigger signal	Trigger contents
0	0	0	0	–	Disables DMA transfer by interrupt. (Only software trigger is enabled.)
0	0	0	1	INTAD	A/D conversion end interrupt
0	0	1	0	INTTM00	End of timer channel 0 count or capture end interrupt
0	0	1	1	INTTM01	End of timer channel 1 count or capture end interrupt
0	1	0	0	INTTM02	End of timer channel 2 count or capture end interrupt
0	1	0	1	INTTM03	End of timer channel 3 count or capture end interrupt
0	1	1	0	INTST0/INTCSI00	UART0 transmission transfer end or buffer empty interrupt/CSI00 transfer end or buffer empty interrupt
0	1	1	1	INTSR0/INTCSI01	UART0 reception transfer end interrupt/CSI01 transfer end or buffer empty interrupt
1	0	0	0	INTST1/INTCSI10	UART1 transmission transfer end or buffer empty interrupt/CSI10 transfer end or buffer empty interrupt
1	0	0	1	INTSR1/INTCSI11	UART1 reception transfer end interrupt/CSI11 transfer end or buffer empty interrupt
1	0	1	0	INTST2/INTCSI20	UART2 transmission transfer end or buffer empty interrupt/CSI20 transfer end or buffer empty interrupt
1	0	1	1	INTSR2/INTCSI21	UART2 reception transfer end interrupt/CSI21 transfer end or buffer empty interrupt
Other than above				Setting prohibited	

**Note** The software trigger (STGn) can be used regardless of the IFCn0 to IFCn3 bits values.

**Remark** n: DMA channel number (n = 0, 1)

Figure 15-4. Format of DMA Mode Control Register n (DMCn) (3/3)

Address: F020AH (DMC2), F020BH (DMC3) After reset: 00H R/W

Symbol	<7>	<6>	<5>	<4>	3	2	1	0
DMCn	STGn	DRSn	DSn	DWAITn	IFCn3	IFCn2	IFCn1	IFCn0

(When n = 2 or 3)

IFCn 3	IFCn 2	IFCn 1	IFCn 0	Selection of DMA start source <sup>Note</sup>	
				Trigger signal	Trigger contents
0	0	0	0	–	Disables DMA transfer by interrupt. (Only software trigger is enabled.)
0	0	0	1	INTAD	A/D conversion end interrupt
0	0	1	0	INTTM10	End of timer channel 10 count or capture end interrupt
0	0	1	1	INTTM11	End of timer channel 11 count or capture end interrupt
0	1	0	0	INTTM12	End of timer channel 12 count or capture end interrupt
0	1	0	1	INTTM13	End of timer channel 13 count or capture end interrupt
0	1	1	0	INTST3/INTCSI30	UART3 transmission transfer end or buffer empty interrupt/CSI30 transfer end or buffer empty interrupt
0	1	1	1	INTSR3/INTCSI31	UART3 reception transfer end interrupt/CSI31 transfer end or buffer empty interrupt
1	0	0	0	INTST1/INTCSI10	UART1 transmission transfer end or buffer empty interrupt/CSI10 transfer end or buffer empty interrupt
1	0	0	1	INTSR1/INTCSI11	UART1 reception transfer end interrupt/CSI11 transfer end or buffer empty interrupt
1	0	1	0	INTST2/INTCSI20	UART2 transmission transfer end or buffer empty interrupt/CSI20 transfer end or buffer empty interrupt
1	0	1	1	INTSR2/INTCSI21	UART2 reception transfer end interrupt/CSI21 transfer end or buffer empty interrupt
Other than above				Setting prohibited	

**Note** The software trigger (STGn) can be used regardless of the IFCn0 to IFCn3 bits values.

**Remark** n: DMA channel number (n = 2, 3)

**(2) DMA operation control register n (DRCn)**

The DRCn register is a register that is used to enable or disable transfer of DMA channel n. Rewriting bit 7 (DENn) of this register is prohibited during operation (when DSTn = 1). The DRCn register can be set by a 1-bit or 8-bit memory manipulation instruction. Reset signal generation clears this register to 00H.

**Figure 15-5. Format of DMA Operation Control Register n (DRCn)**

Address: FFFBCH (DRC0), FFFBDH (DRC1), F020CH (DRC2), F020DH (DRC3) After reset: 00H R/W

Symbol	<7>	6	5	4	3	2	1	<0>
DRCn	DENn	0	0	0	0	0	0	DSTn

DENn	DMA operation enable flag
0	Disables operation of DMA channel n (stops operating clock of DMA).
1	Enables operation of DMA channel n.
DMAC waits for a DMA trigger when DSTn = 1 after DMA operation is enabled (DENn = 1).	

DSTn	DMA transfer mode flag
0	DMA transfer of DMA channel n is completed.
1	DMA transfer of DMA channel n is not completed (still under execution).
DMAC waits for a DMA trigger when DSTn = 1 after DMA operation is enabled (DENn = 1). When a software trigger (STGn) or the start source trigger set by the IFCn3 to IFCn0 bits is input, DMA transfer is started. When DMA transfer is completed after that, this bit is automatically cleared to 0. Write 0 to this bit to forcibly terminate DMA transfer under execution.	

**Caution** The DSTn flag is automatically cleared to 0 when a DMA transfer is completed. Writing the DENn flag is enabled only when DSTn = 0. When a DMA transfer is terminated without waiting for generation of the interrupt (INTDMAn) of DMAn, therefore, set the DSTn bit to 0 and then the DENn bit to 0 (for details, refer to 15.5.5 Forced termination by software).

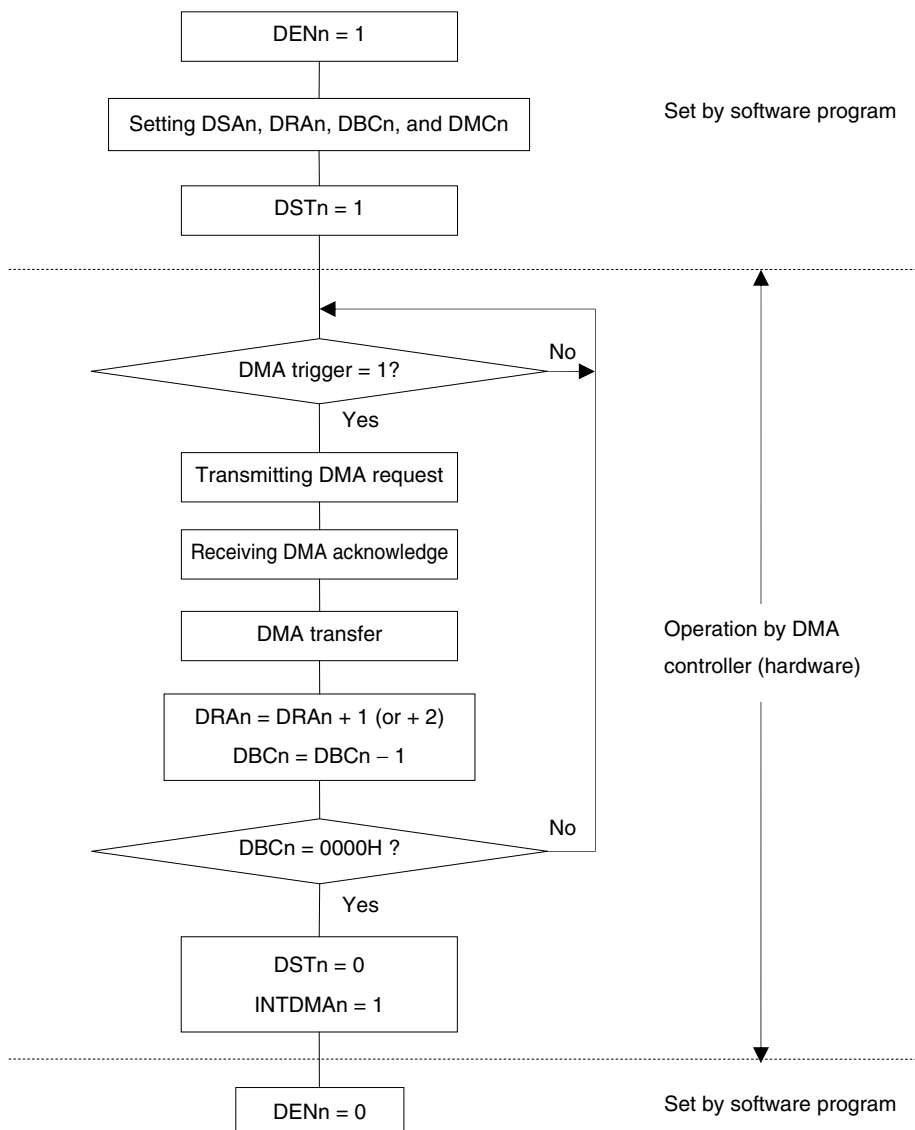
**Remark** n: DMA channel number (n = 0 to 3)

### 15.4 Operation of DMA Controller

#### 15.4.1 Operation procedure

- <1> The DMA controller is enabled to operate when DENn = 1. Before writing the other registers, be sure to set the DENn bit to 1. Use 80H to write with an 8-bit manipulation instruction.
- <2> Set an SFR address, a RAM address, the number of times of transfer, and a transfer mode of DMA transfer to DMA SFR address register n (DSAn), DMA RAM address register n (DRAn), DMA byte count register n (DBCn), and DMA mode control register n (DMCn).
- <3> The DMA controller waits for a DMA trigger when DSTn = 1. Use 81H to write with an 8-bit manipulation instruction.
- <4> When a software trigger (STGn) or a start source trigger specified by the IFCn3 to IFCn0 bits is input, a DMA transfer is started.
- <5> Transfer is completed when the number of times of transfer set by the DBCn register reaches 0, and transfer is automatically terminated by occurrence of an interrupt (INTDMA<sub>n</sub>).
- <6> Stop the operation of the DMA controller by clearing the DENn bit to 0 when the DMA controller is not used.

**Figure 15-6. Operation Procedure**



**Remark** n: DMA channel number (n = 0 to 3)

### 15.4.2 Transfer mode

The following four modes can be selected for DMA transfer by using bits 6 and 5 (DRSn and DS<sub>n</sub>) of DMA mode control register n (DMCn).

DRSn	DS <sub>n</sub>	DMA Transfer Mode
0	0	Transfer from SFR of 1-byte data (fixed address) to RAM (address is incremented by +1)
0	1	Transfer from SFR of 2-byte data (fixed address) to RAM (address is incremented by +2)
1	0	Transfer from RAM of 1-byte data (address is incremented by +1) to SFR (fixed address)
1	1	Transfer from RAM of 2-byte data (address is incremented by +2) to SFR (fixed address)

By using these transfer modes, up to 1024 bytes of data can be consecutively transferred by using the serial interface, data resulting from A/D conversion can be consecutively transferred, and port data can be scanned at fixed time intervals by using a timer.

### 15.4.3 Termination of DMA transfer

When DBCn = 00H and DMA transfer is completed, the DSTn bit is automatically cleared to 0. An interrupt request (INTDMA<sub>n</sub>) is generated and transfer is terminated.

When the DSTn bit is cleared to 0 to forcibly terminate DMA transfer, DMA byte count register n (DBCn) and DMA RAM address register n (DRAn) hold the value when transfer is terminated.

The interrupt request (INTDMA<sub>n</sub>) is not generated if transfer is forcibly terminated.

**Remark** n: DMA channel number (n = 0 to 3)

## 15.5 Example of Setting of DMA Controller

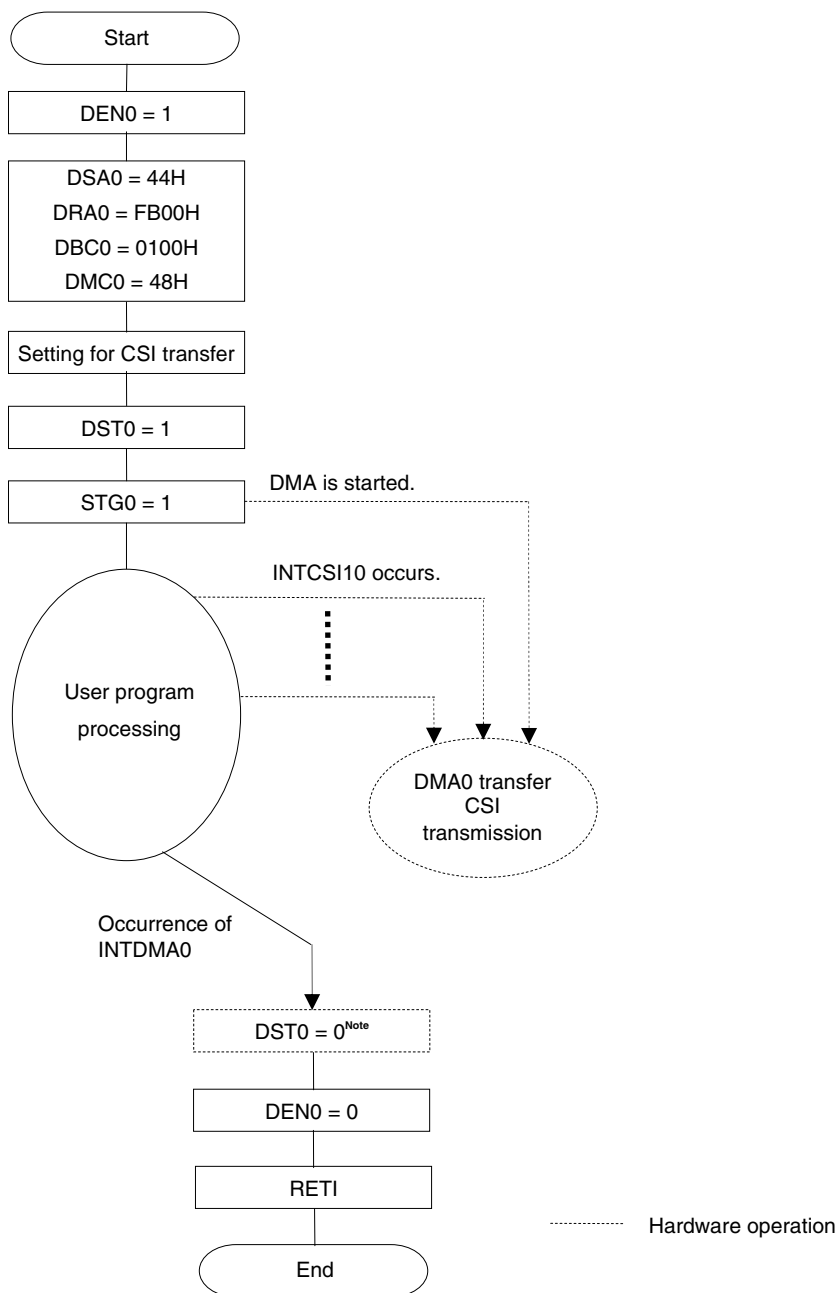
### 15.5.1 CSI consecutive transmission

A flowchart showing an example of setting for CSI consecutive transmission is shown below.

- Consecutive transmission of CSI10 (256 bytes)
- DMA channel 0 is used for DMA transfer.
- DMA start source: INTCSI10 (software trigger (STG0) only for the first start source)
- Interrupt of CSI10 is specified by IFC03 to IFC00 = 1000B.
- Transfers FFB00H to FFBFFH (256 bytes) of RAM to FFF44H of the data register (SIO10) of CSI.

**Remark** IFC03 to IFC00: Bits 3 to 0 of DMA mode control registers 0 (DMC0)

Figure 15-7. Example of Setting for CSI Consecutive Transmission



**Note** The DST0 flag is automatically cleared to 0 when a DMA transfer is completed. Writing the DEN0 flag is enabled only when DST0 = 0. To terminate a DMA transfer without waiting for occurrence of the interrupt of DMA0 (INTDMA0), set the DST0 bit to 0 and then the DEN0 bit to 0 (for details, refer to 15.5.5 Forced termination by software).

The first trigger for consecutive transmission is not started by the interrupt of CSI. In this example, it starts by a software trigger.

CSI transmission of the second time and onward is automatically executed.

A DMA interrupt (INTDMA0) occurs when the last transmit data has been written to the data register.

### 15.5.2 Consecutive capturing of A/D conversion results

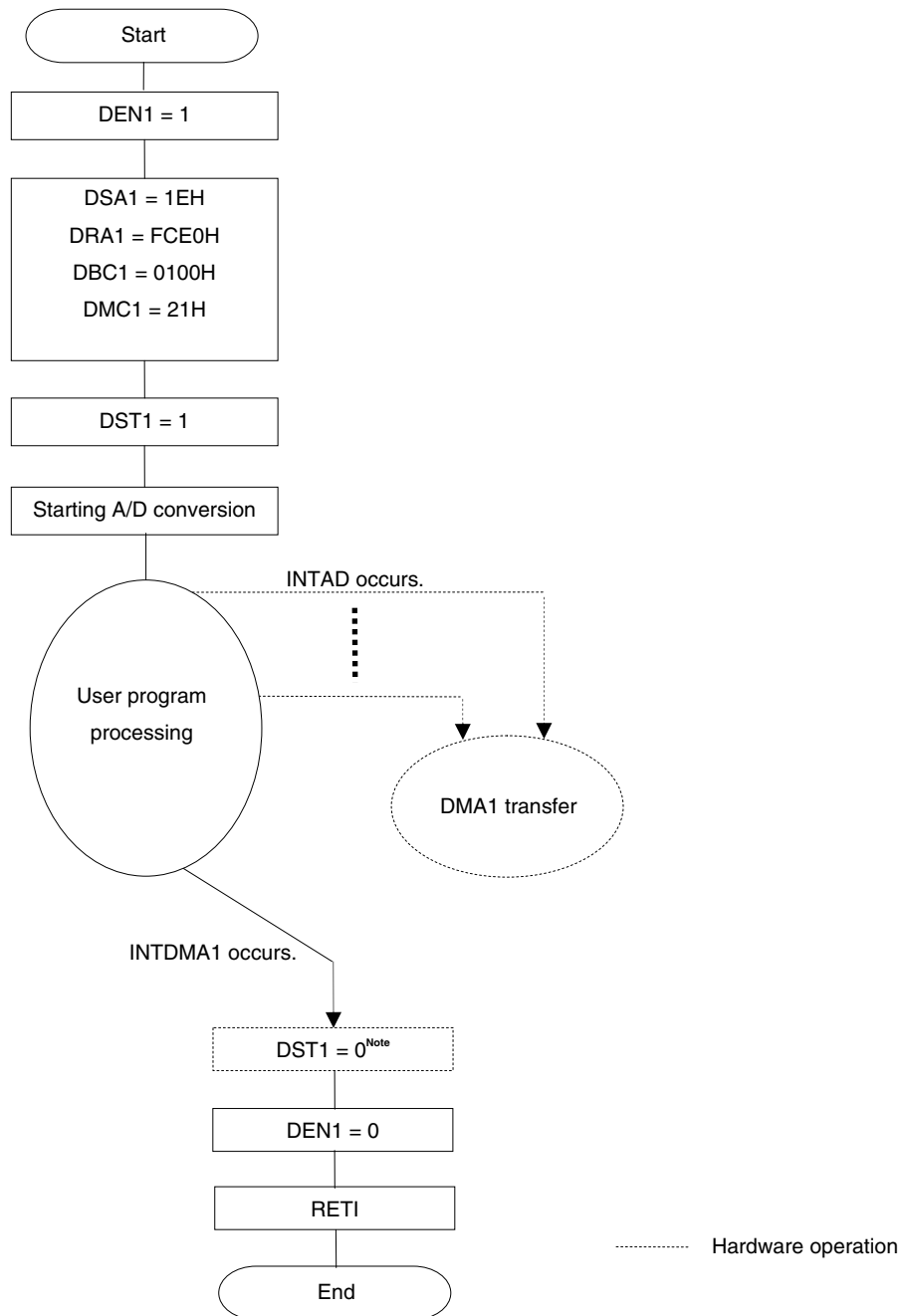
A flowchart of an example of setting for consecutively capturing A/D conversion results is shown below.

- Consecutive capturing of A/D conversion results.
- DMA channel 1 is used for DMA transfer.
- DMA start source: INTAD
- Interrupt of A/D is specified by IFC13 to IFC10 = 0001B.
- Transfers FFF1EH and FFF1FH (2 bytes) of the 10-bit A/D conversion result register (ADCR) to 512 bytes of FFCE0H to FFEDFH of RAM.

**Remark** IFC13 to IFC10: Bits 3 to 0 of DMA mode control registers 1 (DMC1)



Figure 15-8. Example of Setting of Consecutively Capturing A/D Conversion Results



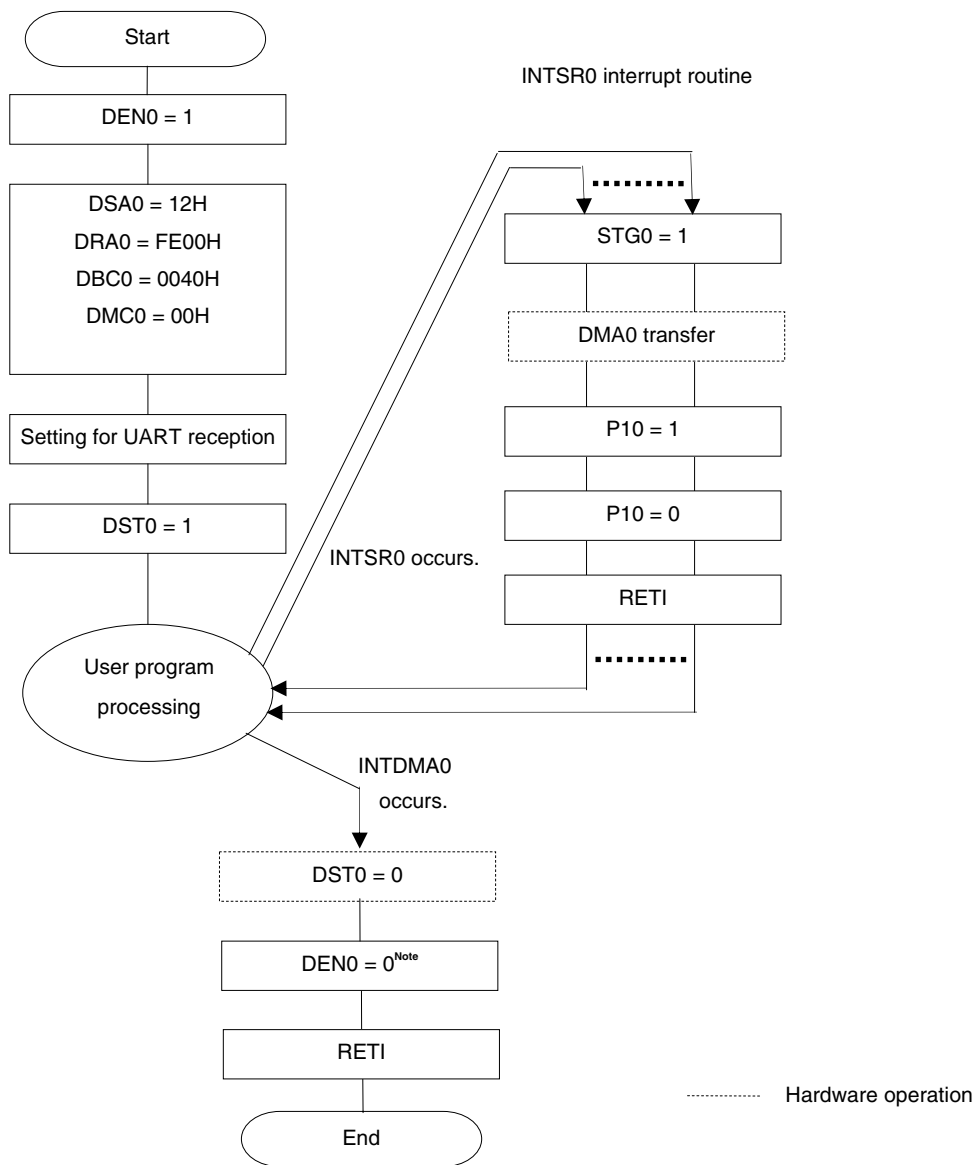
**Note** The DST1 flag is automatically cleared to 0 when a DMA transfer is completed. Writing the DEN1 flag is enabled only when DST1 = 0. To terminate a DMA transfer without waiting for occurrence of the interrupt of DMA1 (INTDMA1), set the DST1 bit to 0 and then the DEN1 bit to 0 (for details, refer to 15.5.5 Forced termination by software).

### 15.5.3 UART consecutive reception + ACK transmission

A flowchart illustrating an example of setting for UART consecutive reception + ACK transmission is shown below.

- Consecutively receives data from UART0 and outputs ACK to P10 on completion of reception.
- DMA channel 0 is used for DMA transfer.
- DMA start source: Software trigger (DMA transfer on occurrence of an interrupt is disabled.)
- Transfers FFF12H of UART receive data register 0 (RXD0) to 64 bytes of FFE00H to FFE3FH of RAM.

Figure 15-9. Example of Setting for UART Consecutive Reception + ACK Transmission



**Note** The DST0 flag is automatically cleared to 0 when a DMA transfer is completed. Writing the DEN0 flag is enabled only when DST0 = 0. To terminate a DMA transfer without waiting for occurrence of the interrupt of DMA0 (INTDMA0), set the DST0 bit to 0 and then the DEN0 bit to 0 (for details, refer to 15.5.5 Forced termination by software).

**Remark** This is an example where a software trigger is used as a DMA start source. If ACK is not transmitted and if only data is consecutively received from UART, the UART reception end interrupt (INTSR0) can be used to start DMA for data reception.

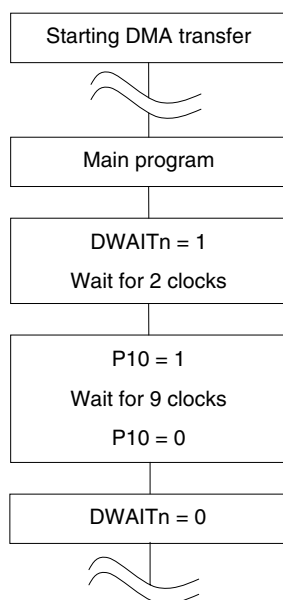
### 15.5.4 Holding DMA transfer pending by DWAITn bit

When DMA transfer is started, transfer is performed while an instruction is executed. At this time, the operation of the CPU is stopped and delayed for the duration of 2 clocks. If this poses a problem to the operation of the set system, a DMA transfer can be held pending by setting the DWAITn bit to 1. The DMA transfer for a transfer trigger that occurred while DMA transfer was held pending is executed after the pending status is canceled. However, because only one transfer trigger can be held pending for each channel, even if multiple transfer triggers occur for one channel during the pending status, only one DMA transfer is executed after the pending status is canceled.

To output a pulse with a width of 10 clocks of the operating frequency from the P10 pin, for example, the clock width increases to 12 if a DMA transfer is started midway. In this case, the DMA transfer can be held pending by setting the DWAITn bit to 1.

After setting the DWAITn bit to 1, it takes two clocks until a DMA transfer is held pending.

**Figure 15-10. Example of Setting for Holding DMA Transfer Pending by DWAITn Bit**



**Caution** When DMA transfer is held pending while using two or more DMA channels, be sure to held the DMA transfer pending for all channels (by setting DWAIT0, DWAIT1, DWAIT2, and DWAIT3 to 1). If the DMA transfer of one channel is executed while that of the other channel is held pending, DMA transfer might not be held pending for the latter channel.

- Remarks**
1. n: DMA channel number (n = 0 to 3)
  2. 1 clock:  $1/f_{CLK}$  ( $f_{CLK}$ : CPU clock)

### 15.5.5 Forced termination by software

After the DSTn bit is set to 0 by software, it takes up to 2 clocks until a DMA transfer is actually stopped and the DSTn bit is set to 0. To forcibly terminate a DMA transfer by software without waiting for occurrence of the interrupt (INTDMA<sub>n</sub>) of DMA<sub>n</sub>, therefore, perform either of the following processes.

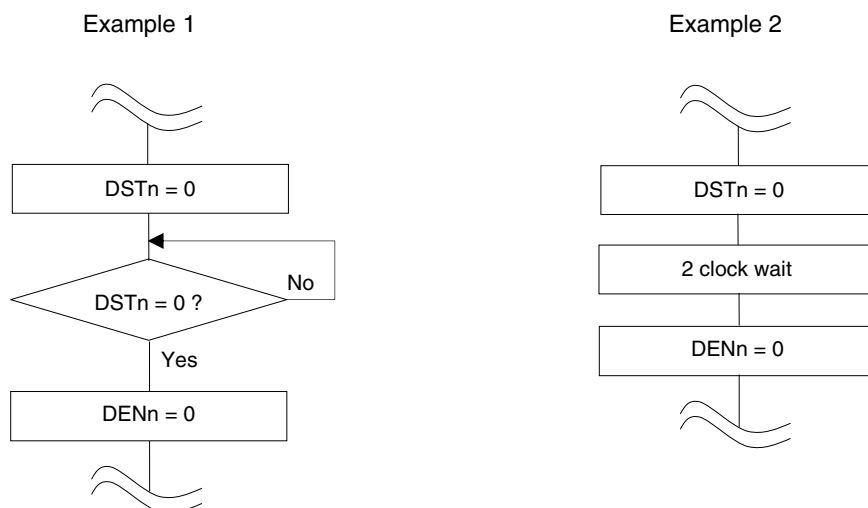
<When using one DMA channel>

- Set the DSTn bit to 0 (use DRCn = 80H to write with an 8-bit manipulation instruction) by software, confirm by polling that the DSTn bit has actually been cleared to 0, and then set the DENn bit to 0 (use DRCn = 00H to write with an 8-bit manipulation instruction).
- Set the DSTn bit to 0 (use DRCn = 80H to write with an 8-bit manipulation instruction) by software and then set the DENn bit to 0 (use DRCn = 00H to write with an 8-bit manipulation instruction) two or more clocks after.

<When using two or more DMA channels>

- To forcibly terminate DMA transfer by software when using two or more DMA channels (by setting DSTn to 0), clear the DSTn bit to 0 after the DMA transfer is held pending by setting the DWAITn bits of all using channels to 1. Next, clear the DWAITn bits of all using channels to 0 to cancel the pending status, and then clear the DENn bit to 0.

**Figure 15-11. Forced Termination of DMA Transfer (1/2)**



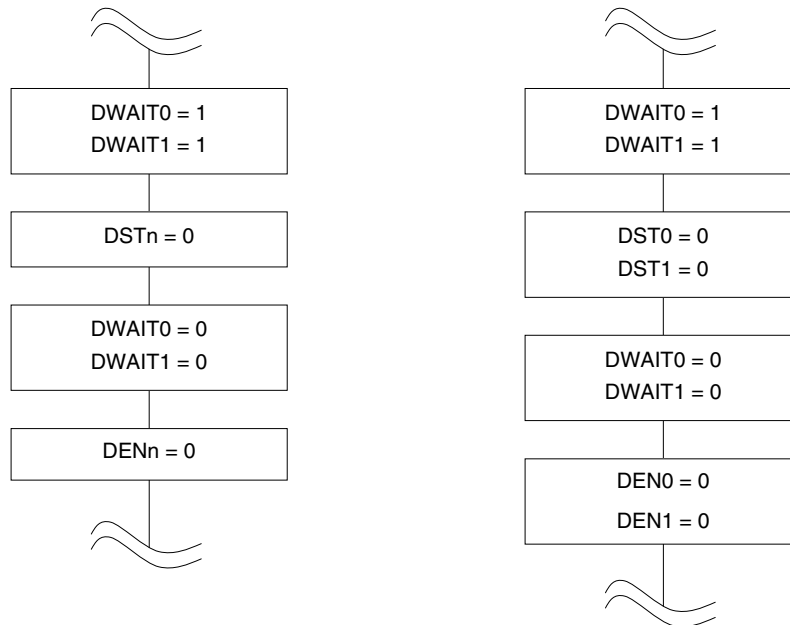
- Remarks**
1. n: DMA channel number (n = 0 to 3)
  2. 1 clock:  $1/f_{CLK}$  ( $f_{CLK}$ : CPU clock)

Figure 15-11. Forced Termination of DMA Transfer (2/2)

Example 3

- Procedure for forcibly terminating the DMA transfer for one channel if both channels are used

- Procedure for forcibly terminating the DMA transfer for both channels if both channels are used



**Caution** In example 3, the system is not required to wait two clock cycles after the DWAITn bit is set to 1. In addition, the system does not have to wait two clock cycles after clearing the DSTn bit to 0, because more than two clock cycles elapse from when the DSTn bit is cleared to 0 to when the DENn bit is cleared to 0.

- Remarks**
1. n: DMA channel number (n = 0, 1)
  2. 1 clock: 1/f<sub>CLK</sub> (f<sub>CLK</sub>: CPU clock)

### 15.6 Cautions on Using DMA Controller

**(1) Priority of DMA**

During DMA transfer, a request from the other DMA channel is held pending even if generated. The pending DMA transfer is started after the ongoing DMA transfer is completed. If two or more DMA requests are generated at the same time, however, their priority are DMA channel 0 > DMA channel 1 > DMA channel 2 > DMA channel 3. If a DMA request and an interrupt request are generated at the same time, the DMA transfer takes precedence, and then interrupt servicing is executed.

**(2) DMA response time**

The response time of DMA transfer is as follows.

**Table 15-2. Response Time of DMA Transfer**

	Minimum Time	Maximum Time
Response time	3 clocks	10 clocks <sup>Note</sup>

**Note** The maximum time necessary to execute an instruction from internal RAM is 16 clock cycles.

**Cautions 1.** The above response time does not include the two clock cycles required for a DMA transfer.

2. When executing a DMA pending instruction (see 15.6 (4)), the maximum response time is extended by the execution time of that instruction to be held pending.
3. Do not specify successive transfer triggers for a channel within a period equal to the maximum response time plus one clock cycle, because they might be ignored.

**Remark** 1 clock: 1/f<sub>CLK</sub> (f<sub>CLK</sub>: CPU clock)

**(3) Operation in standby mode**

The DMA controller operates as follows in the standby mode.

**Table 15-3. DMA Operation in Standby Mode**

Status	DMA Operation
HALT mode	Normal operation
STOP mode	Stops operation. If DMA transfer and STOP instruction execution contend, DMA transfer may be damaged. Therefore, stop DMA before executing the STOP instruction.

**(4) DMA pending instruction**

Even if a DMA request is generated, DMA transfer is held pending immediately after the following instructions.

- CALL !addr16
- CALL \$!addr20
- CALL !!addr20
- CALL rp
- CALLT [addr5]
- BRK
- Bit manipulation instructions for registers IF0L, IF0H, IF1L, IF1H, IF2L, IF2H, IF3L, MK0L, MK0H, MK1L, MK1H, MK2L, MK2H, MK3L, PR00L, PR00H, PR01L, PR01H, PR02L, PR02H, PR03L, PR10L, PR10H, PR11L, PR11H, PR12L, PR12H, PR13L, and PSW each.
- Instruction for accessing the data flash memory

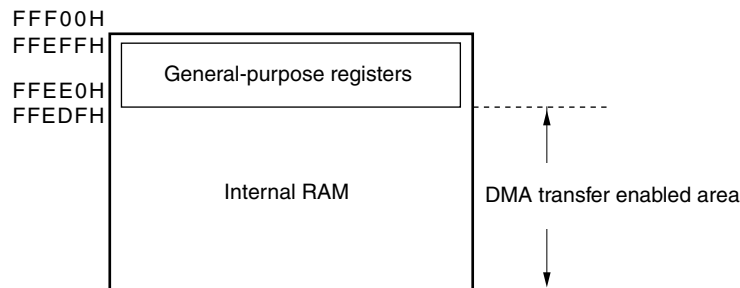
&lt;R&gt;

**(5) Operation if address in general-purpose register area or other than those of internal RAM area is specified**

The address indicated by DMA RAM address register n (DRAn) is incremented during DMA transfer. If the address is incremented to an address in the general-purpose register area or exceeds the area of the internal RAM, the following operation is performed.

- In mode of transfer from SFR to RAM  
The data of that address is lost.
- In mode of transfer from RAM to SFR  
Undefined data is transferred to SFR.

In either case, malfunctioning may occur or damage may be done to the system. Therefore, make sure that the address is within the internal RAM area other than the general-purpose register area.

**(6) Operation if instructions for accessing the data flash area**

- Because DMA transfer is suspended to access to the data flash area, be sure to add the DMA pending instruction.

If the data flash area is accessed after an next instruction execution from start of DMA transfer, a 3-clock wait will be inserted to the next instruction.

Instruction 1

DMA transfer

Instruction 2 ← The wait of three clock cycles occurs.

MOV A, !DataFlash area



## CHAPTER 16 INTERRUPT FUNCTIONS

The function to switch the flow of the program temporarily.

The number of interrupt sources differs, depending on the product.

		20-pin	24, 25-pin	30, 32, 36-pin	40, 44-pin	48-pin	52-pin	64-pin	80, 100-pin	128-pin
Maskable interrupts	External	3	5	6	7	10	12	13	13	13
	Internal	23	24	27	27	27	27	27	37	41

### 16.1 Interrupt Function Types

The following two types of interrupt functions are used.

#### (1) Maskable interrupts

These interrupts undergo mask control. Maskable interrupts can be divided into four priority groups by setting the priority specification flag registers (PR00L, PR00H, PR01L, PR01H, PR02L, PR02H, PR03L, PR10L, PR10H, PR11L, PR11H, PR12L, PR12H, PR13L).

Multiple interrupt servicing can be applied to low-priority interrupts when high-priority interrupts are generated. If two or more interrupt requests, each having the same priority, are simultaneously generated, then they are processed according to the default priority of vectored interrupt servicing. Default priority, see **Table 16-1**.

A standby release signal is generated and STOP, HALT, and SNOOZE modes are released.

External interrupt requests and internal interrupt requests are provided as maskable interrupts.

#### (2) Software interrupt

This is a vectored interrupt generated by executing the BRK instruction. It is acknowledged even when interrupts are disabled. The software interrupt does not undergo interrupt priority control.

### 16.2 Interrupt Sources and Configuration

Interrupt sources include maskable interrupts and software interrupts. In addition, they also have up to seven reset sources (see **Table 16-1**). The vector codes that store the program start address when branching due to the generation of a reset or various interrupt requests are two bytes each, so interrupts jump to a 64 K address of 00000H to 0FFFFH.

Table 16-1. Interrupt Source List (1/4)

Interrupt Type	Default Priority <sup>Note 1</sup>	Interrupt Source		Internal/External	Vector Table Address	Basic Configuration Type <sup>Note 2</sup>	128-pin	100-pin	80-pin	64-pin	52-pin	48-pin	44-pin	40-pin	36-pin	32-pin	30-pin	25-pin	24-pin	20-pin			
		Name	Trigger																				
<R>	0	INTWDTI	Watchdog timer interval <sup>Note 3</sup> (75% of overflow time+1/2f <sub>IL</sub> )	Internal	0004H	(A)	√	√	√	√	√	√	√	√	√	√	√	√	√	√			
	1	INTLVI	Voltage detection <sup>Note 4</sup>		0006H		√	√	√	√	√	√	√	√	√	√	√	√	√	√	√		
	2	INTP0	Pin input edge detection	External	0008H	(B)	√	√	√	√	√	√	√	√	√	√	√	√	√	√			
	3	INTP1			000AH		√	√	√	√	√	√	√	√	√	√	√	√	√	√	√	—	
	4	INTP2			000CH		√	√	√	√	√	√	√	√	√	√	√	√	√	√	—	—	—
	5	INTP3			000EH		√	√	√	√	√	√	√	√	√	√	√	√	√	√	√	√	√
	6	INTP4			0010H		√	√	√	√	√	√	√	√	√	√	√	√	√	√	√	√	—
	7	INTP5			0012H		√	√	√	√	√	√	√	√	√	√	√	√	√	√	√	√	√
	8	INTST2/ INTCSI20/ INTIIC20			UART2 transmission transfer end or buffer empty interrupt/CSI20 transfer end or buffer empty interrupt/IIC20 transfer end		Internal	0014H	(A)	√	√	√	√	√	√	√	√	√	√	√	√	—	—
	9	INTSR2/ INTCSI21/ INTIIC21	UART2 reception transfer end/CSI21 transfer end or buffer empty interrupt/IIC21 transfer end	0016H	√	√		√		√	√	√	√	√	√	√	√	√	√	—	—	—	
	10	INTSRE2	UART2 reception communication error occurrence	0018H	√	√		√		√	√	√	√	√	√	√	√	√	√	—	—	—	
		INTTM11H	End of timer channel 11 count or capture (at 8-bit timer operation)		√	√		√		—	—	—	—	—	—	—	—	—	—	—	—	—	—
	11	INTDMA0	End of DMA0 transfer	001AH	√	√		√		√	√	√	√	√	√	√	√	√	√	√	√	√	
	12	INTDMA1	End of DMA1 transfer	001CH	√	√		√		√	√	√	√	√	√	√	√	√	√	√	√	√	
	13	INTST0/ INTCSI00/ INTIIC00	UART0 transmission transfer end or buffer empty interrupt/CSI00 transfer end or buffer empty interrupt/IIC00 transfer end	001EH	√	√		√		√	√	√	√	√	√	√	√	√	√	√	√	√	
14	INTSR0/ INTCSI01/ INTIIC01	UART0 reception transfer end/CSI01 transfer end or buffer empty interrupt/IIC01 transfer end	0020H	√	√	√		√		√	√	√	√	√	√	√	√	√	√	√	√	√	
15	INTSRE0	UART0 reception communication error occurrence	0022H	√	√	√		√		√	√	√	√	√	√	√	√	√	√	√	√	√	
	INTTM01H	End of timer channel 1 count or capture (at 8-bit timer operation)		√	√	√		√		√	√	√	√	√	√	√	√	√	√	√	√	√	

- Notes 1.** The default priority determines the sequence of interrupts if two or more maskable interrupts occur simultaneously. Zero indicates the highest priority and 53 indicates the lowest priority.
- 2.** Basic configuration types (A) to (D) correspond to (A) to (D) in Figure 16-1.
- 3.** When bit 7 (WDTINT) of the option byte (000C0H) is set to 1.
- 4.** When bit 7 (LVIMD) of the voltage detection level register (LVIS) is cleared to 0.
- 5.** INTSR2 only.
- 6.** INTSR0 only.

Table 16-1. Interrupt Source List (2/4)

Interrupt Type	Default Priority <sup>Note 1</sup>	Interrupt Source		Internal/ External	Vector Table Address	Basic Configuration Type <sup>Note 2</sup>	Basic Configuration														
		Name	Trigger				128-pin	100-pin	80-pin	64-pin	52-pin	48-pin	44-pin	40-pin	36-pin	32-pin	30-pin	25-pin	24-pin	20-pin	
Maskable	16	INTST1/ INTCSI10/ INTIIC10	UART1 transmission transfer end or buffer empty interrupt/CSI10 transfer end or buffer empty interrupt/IIC10 transfer end	Internal	0024H	(A)	√	√	√	√	Note 3	Note 3	Note 3	Note 3	Note 3	Note 3	Note 3	Note 3	Note 3	Note 3	
	17	INTSR1/ INTCSI11/ INTIIC11	UART1 reception transfer end/CSI11 transfer end or buffer empty interrupt/IIC11 transfer end		0026H	√	√	√	√	√	√	√	√	√	√	√	√	√	√	√	√
	18	INTSRE1	UART1 reception communication error occurrence		0028H	√	√	√	√	√	√	√	√	√	√	√	√	√	√	√	√
		INTTM03H	End of timer channel 3 count or capture (at 8-bit timer operation)			√	√	√	√	√	√	√	√	√	√	√	√	√	√	√	√
	19	INTIICA0	End of IICA0 communication		002AH	√	√	√	√	√	√	√	√	√	√	√	√	√	√	√	-
	20	INTTM00	End of timer channel 0 count or capture		002CH	√	√	√	√	√	√	√	√	√	√	√	√	√	√	√	√
	21	INTTM01	End of timer channel 1 count or capture		002EH	√	√	√	√	√	√	√	√	√	√	√	√	√	√	√	√
	22	INTTM02	End of timer channel 2 count or capture		0030H	√	√	√	√	√	√	√	√	√	√	√	√	√	√	√	√
	23	INTTM03	End of timer channel 3 count or capture		0032H	√	√	√	√	√	√	√	√	√	√	√	√	√	√	√	√
	24	INTAD	End of A/D conversion		0034H	√	√	√	√	√	√	√	√	√	√	√	√	√	√	√	√
	25	INTRTC	Fixed-cycle signal of real-time clock/alarm match detection		0036H	√	√	√	√	√	√	√	√	√	√	√	√	√	√	√	√
	26	INTIT	Interval signal detection		0038H	√	√	√	√	√	√	√	√	√	√	√	√	√	√	√	√
	27	INTKR	Key return signal detection		External	003AH	(C)	√	√	√	√	√	√	√	√	-	-	-	-	-	-
		28	INTST3/ INTCSI30/ INTIIC30		UART3 transmission transfer end or buffer empty interrupt/CSI30 transfer end or buffer empty interrupt/IIC30 transfer end	Internal	003CH	(A)	√	√	√	-	-	-	-	-	-	-	-	-	-
		29	INTSR3/ INTCSI31/ INTIIC31		UART3 reception transfer end/CSI31 transfer end or buffer empty interrupt/IIC31 transfer end		003EH	√	√	√	-	-	-	-	-	-	-	-	-	-	-
30		INTTM13	End of timer channel 13 count or capture	0040H	√		√	√	-	-	-	-	-	-	-	-	-	-	-	-	
31		INTTM04	End of timer channel 4 count or capture	0042H	√		√	√	√	√	√	√	√	√	√	√	√	√	√	√	√

- Notes**
- The default priority determines the sequence of interrupts if two or more maskable interrupts occur simultaneously. Zero indicates the highest priority and 53 indicates the lowest priority.
  - Basic configuration types (A) to (D) correspond to (A) to (D) in Figure 16-1.
  - INTST1 only.

Table 16-1. Interrupt Source List (3/4)

Interrupt Type	Default Priority <sup>Note 1</sup>	Interrupt Source		Internal/ External	Vector Table Address	Basic Configuration Type <sup>Note 2</sup>	Basic Configuration															
		Name	Trigger				128-pin	100-pin	80-pin	64-pin	52-pin	48-pin	44-pin	40-pin	36-pin	32-pin	30-pin	25-pin	24-pin	20-pin		
<R>	32	INTTM05	End of timer channel 5 count or capture	Internal	0044H	(A)	√	√	√	√	√	√	√	√	√	√	√	√	√	√		
	33	INTTM06	End of timer channel 6 count or capture		0046H		√	√	√	√	√	√	√	√	√	√	√	√	√	√	√	
	34	INTTM07	End of timer channel 7 count or capture		0048H		√	√	√	√	√	√	√	√	√	√	√	√	√	√	√	
	35	INTP6	Pin input edge detection	External	004AH	(B)	√	√	√	√	√	√	-	-	-	-	-	-	-	-		
	36	INTP7			004CH		√	√	√	√	-	-	-	-	-	-	-	-	-	-	-	
	37	INTP8			004EH		√	√	√	√	√	√	-	-	-	-	-	-	-	-	-	
	38	INTP9			0050H		√	√	√	√	√	√	-	-	-	-	-	-	-	-	-	
	39	INTP10			0052H		√	√	√	√	√	-	-	-	-	-	-	-	-	-	-	
	40	INTP11			0054H		√	√	√	√	√	-	-	-	-	-	-	-	-	-	-	
	<R>	41	INTTM10	End of timer channel 10 count or capture	Internal	0056H	(A)	√	√	√	-	-	-	-	-	-	-	-	-	-		
42		INTTM11	End of timer channel 11 count or capture	0058H		√		√	√	-	-	-	-	-	-	-	-	-	-	-		
43		INTTM12	End of timer channel 12 count or capture	005AH		√		√	√	-	-	-	-	-	-	-	-	-	-	-		
44		INTSRE3	UART3 reception communication error occurrence	005CH	√	√	√	-	-	-	-	-	-	-	-	-	-	-	-			
		INTTM13H	End of timer channel 13 count or capture (at 8-bit timer operation)		√	√	√	-	-	-	-	-	-	-	-	-	-	-	-			
45		INTMD	End of division operation/ Overflow occur	005EH	√	√	√	√	√	√	√	√	√	√	√	√	√	√	√			
46		INTIICA1	End of IICA1 communication	0060H	√	√	√	-	-	-	-	-	-	-	-	-	-	-	-			
47		INTFL	End of sequencer interrupt <sup>Note 3</sup>	0062H	√	√	√	√	√	√	√	√	√	√	√	√	√	√	√			
48		INTDMA2	End of DMA2 transfer	0064H	√	√	√	-	-	-	-	-	-	-	-	-	-	-	-			
49		INTDMA3	End of DMA3 transfer	0066H	√	√	√	-	-	-	-	-	-	-	-	-	-	-	-			
50	INTTM14	End of timer channel 14 count or capture	0068H	√	-	-	-	-	-	-	-	-	-	-	-	-	-	-				
51	INTTM15	End of timer channel 15 count or capture	006AH	√	-	-	-	-	-	-	-	-	-	-	-	-	-	-				
52	INTTM16	End of timer channel 16 count or capture	006CH	√	-	-	-	-	-	-	-	-	-	-	-	-	-	-				
53	INTTM17	End of timer channel 17 count or capture	006EH	√	-	-	-	-	-	-	-	-	-	-	-	-	-	-				

- Notes**
1. The default priority determines the sequence of interrupts if two or more maskable interrupts occur simultaneously. Zero indicates the highest priority and 53 indicates the lowest priority.
  2. Basic configuration types (A) to (D) correspond to (A) to (D) in Figure 16-1.
  3. Be used only at the self programming library.

**Table 16-1. Interrupt Source List (4/4)**

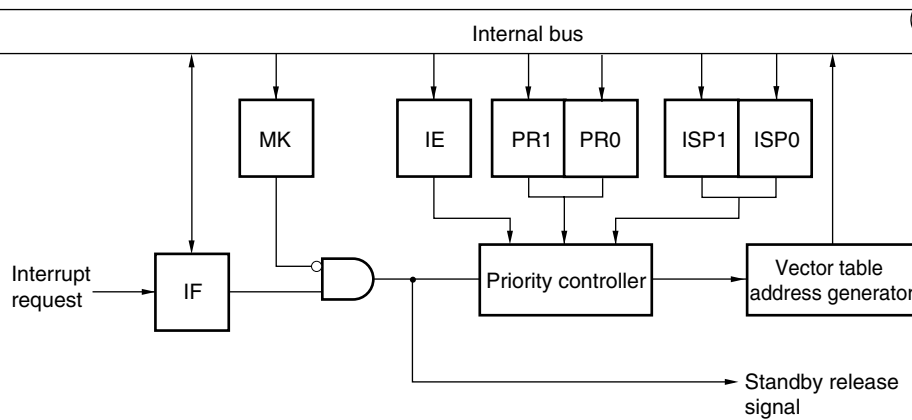
Interrupt Type	Default Priority <sup>Note 1</sup>	Interrupt Source		Internal/ External	Vector Table Address	Basic Configuration Type <sup>Note 2</sup>	20-pin	24-pin	25-pin	30-pin	32-pin	36-pin	40-pin	44-pin	48-pin	52-pin	64-pin	80-pin	100-pin	128-pin					
							√	√	√	√	√	√	√	√	√	√	√	√	√	√	√	√	√	√	
Software	–	BRK	Execution of BRK instruction	–	007EH	(D)	√	√	√	√	√	√	√	√	√	√	√	√	√	√					
Reset	–	RESET	RESET pin input	–	0000H	–	√	√	√	√	√	√	√	√	√	√	√	√	√	√					
		POR	Power-on-reset				√	√	√	√	√	√	√	√	√	√	√	√	√	√	√	√	√		
		LVD	Voltage detection <sup>Note 3</sup>				√	√	√	√	√	√	√	√	√	√	√	√	√	√	√	√	√	√	
		WDT	Overflow of watchdog timer				√	√	√	√	√	√	√	√	√	√	√	√	√	√	√	√	√	√	
		TRAP	Execution of illegal instruction <sup>Note 4</sup>				√	√	√	√	√	√	√	√	√	√	√	√	√	√	√	√	√	√	√
		IAW	Illegal-memory access				√	√	√	√	√	√	√	√	√	√	√	√	√	√	√	√	√	√	√
		RAMTOP	RAM parity error				√	√	√	√	√	√	√	√	√	√	√	√	√	√	√	√	√	√	√

- Notes**
1. The default priority determines the sequence of interrupts if two or more maskable interrupts occur simultaneously. Zero indicates the highest priority and 53 indicates the lowest priority.
  2. Basic configuration types (A) to (D) correspond to (A) to (D) in Figure 16-1.
  3. When bit 7 (LVIMD) of the voltage detection level register (LVIS) is set to 1.
  4. When the instruction code in FFH is executed.  
Reset by the illegal instruction execution not issued by emulation with the in-circuit emulator or on-chip debug emulator.

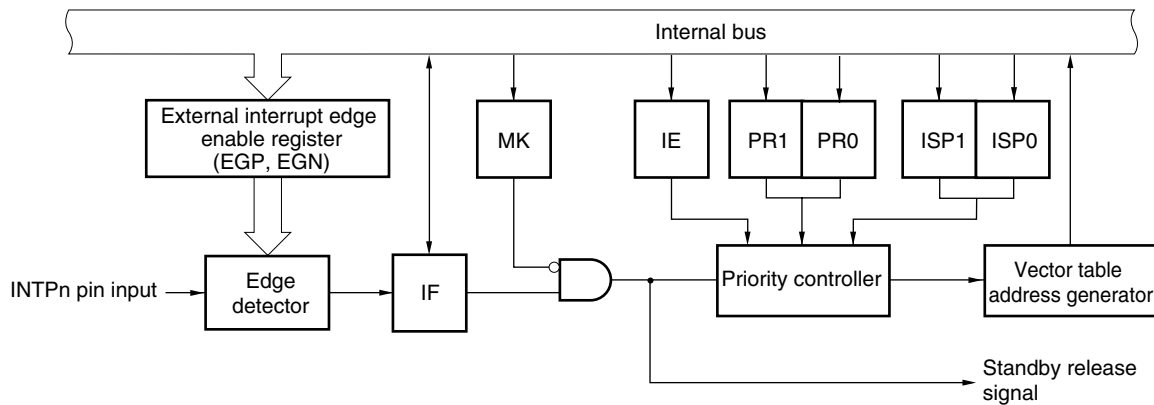
<R>

Figure 16-1. Basic Configuration of Interrupt Function (1/2)

## (A) Internal maskable interrupt



## (B) External maskable interrupt (INTPn)

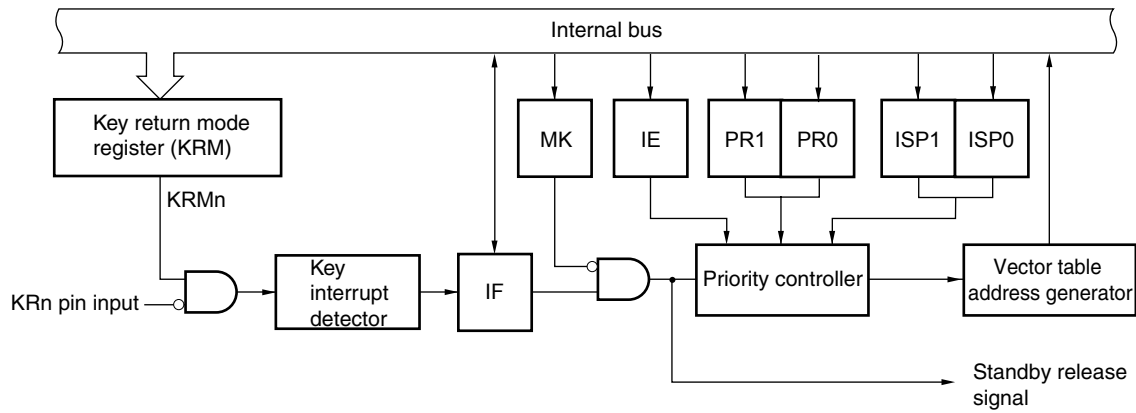


IF:	Interrupt request flag
IE:	Interrupt enable flag
ISP0:	In-service priority flag 0
ISP1:	In-service priority flag 1
MK:	Interrupt mask flag
PR0:	Priority specification flag 0
PR1:	Priority specification flag 1

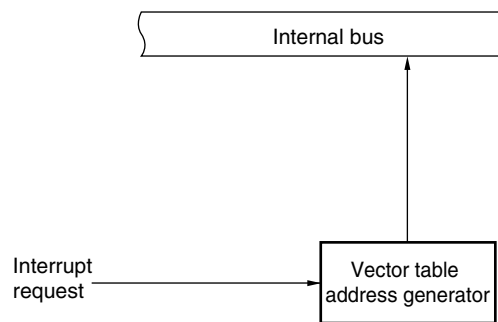
<b>Remark</b>	20-pin:	n = 0, 3, 5
	24, 25-pin:	n = 0, 1, 3 to 5
	30, 32, 36, 40, 44-pin:	n = 0 to 5
	48-pin:	n = 0 to 6, 8, 9
	52-pin:	n = 0 to 6, 8 to 11
	64, 80, 100, 128-pin:	n = 0 to 11

Figure 16-1. Basic Configuration of Interrupt Function (2/2)

(C) External maskable interrupt (INTKR)



(D) Software interrupt



- IF: Interrupt request flag
- IE: Interrupt enable flag
- ISP0: In-service priority flag 0
- ISP1: In-service priority flag 1
- MK: Interrupt mask flag
- PR0: Priority specification flag 0
- PR1: Priority specification flag 1

**Remark** 40, 44-pin: n = 0 to 4  
 48-pin: n = 0 to 5  
 52, 64, 80, 100, 128-pin: n = 0 to 7

### 16.3 Registers Controlling Interrupt Functions

The following 6 types of registers are used to control the interrupt functions.

- Interrupt request flag registers (IF0L, IF0H, IF1L, IF1H, IF2L, IF2H, IF3L)
- Interrupt mask flag registers (MK0L, MK0H, MK1L, MK1H, MK2L, MK2H, MK3L)
- Priority specification flag registers (PR00L, PR00H, PR01L, PR01H, PR02L, PR02H, PR03L, PR10L, PR10H, PR11L, PR11H, PR12L, PR12H, PR13L)
- External interrupt rising edge enable registers (EGP0, EGP1)
- External interrupt falling edge enable registers (EGN0, EGN1)
- Program status word (PSW)

Table 16-2 shows a list of interrupt request flags, interrupt mask flags, and priority specification flags corresponding to interrupt request sources.

**Table 16-2. Flags Corresponding to Interrupt Request Sources (1/4)**

Interrupt Source	Interrupt Request Flag		Interrupt Mask Flag		Priority Specification Flag		128-pin	100-pin	80-pin	64-pin	52-pin	48-pin	40, 44-pin	36-pin	30, 32-pin	24, 25-pin	20-pin		
	Register	Register	Register	Register															
INTWDTI	WDTIIF	IF0L	WDTIMK	MK0L	WDTIPR0, WDTIPR1	PR00L, PR10L	√	√	√	√	√	√	√	√	√	√	√		
INTLVI	LVIIIF		LVIMK		LVIPR0, LVIPR1		√	√	√	√	√	√	√	√	√	√	√	√	√
INTP0	PIF0		PMK0		PPR00, PPR10		√	√	√	√	√	√	√	√	√	√	√	√	√
INTP1	PIF1		PMK1		PPR01, PPR11		√	√	√	√	√	√	√	√	√	√	√	√	—
INTP2	PIF2		PMK2		PPR02, PPR12		√	√	√	√	√	√	√	√	√	√	√	—	—
INTP3	PIF3		PMK3		PPR03, PPR13		√	√	√	√	√	√	√	√	√	√	√	√	√
INTP4	PIF4		PMK4		PPR04, PPR14		√	√	√	√	√	√	√	√	√	√	√	√	—
INTP5	PIF5		PMK5		PPR05, PPR15		√	√	√	√	√	√	√	√	√	√	√	√	√



<R>

**Table 16-2. Flags Corresponding to Interrupt Request Sources (2/4)**

Interrupt Source	Interrupt Request Flag		Interrupt Mask Flag		Priority Specification Flag		18-pin	100-pin	80-pin	64-pin	52-pin	48-pin	40, 44-pin	36-pin	30, 32-pin	24, 25-pin	20-pin			
	Register	Register	Register	Register	Register	Register														
INTST2 <sup>Note 1</sup>	STIF2 <sup>Note 1</sup>	IF0H	STMK2 <sup>Note 1</sup>	MK0H	STPR02, STPR12 <sup>Note 1</sup>	PR00H, PR10H	√	√	√	√	√	√	√	√	√	√	√			
INTCSI20 <sup>Note 1</sup>	CSIF20 <sup>Note 1</sup>		CSIMK20 <sup>Note 1</sup>		CSIPR020, CSIPR120 <sup>Note 1</sup>		√	√	√	√	√	√	√	√	√	√	√	√	√	
INTIIC20 <sup>Note 1</sup>	IICIF20 <sup>Note 1</sup>		IICMK20 <sup>Note 1</sup>		IICPR020, IICPR120 <sup>Note 1</sup>		√	√	√	√	√	√	√	√	√	√	√	√	√	
INTSR2 <sup>Note 2</sup>	SRIF2 <sup>Note 2</sup>		SRMK2 <sup>Note 2</sup>		SRPR02, SRPR12 <sup>Note 2</sup>		√	√	√	√	√	√	√	√	√	√	√	√	√	√
INTCSI21 <sup>Note 2</sup>	CSIF21 <sup>Note 2</sup>		CSIMK21 <sup>Note 2</sup>		CSIPR021, CSIPR121 <sup>Note 2</sup>		√	√	√	√	√	√	√	√	√	√	√	√	√	√
INTIIC21 <sup>Note 2</sup>	IICIF21 <sup>Note 2</sup>		IICMK21 <sup>Note 2</sup>		IICPR021, IICPR121 <sup>Note 2</sup>		√	√	√	√	√	√	√	√	√	√	√	√	√	√
INTSRE2 <sup>Note 3</sup>	SREIF2 <sup>Note 3</sup>	SREMK2 <sup>Note 3</sup>	SREPR02, SREPR12 <sup>Note 3</sup>	√	√	√	√	√	√	√	√	√	√	√	√	√	√			
INTTM11H <sup>Note 3</sup>	TMIF11H <sup>Note 3</sup>			TMMK11H <sup>Note 3</sup>	TMPR011H, TMPR111H <sup>Note 3</sup>	√	√	√	√	√	√	√	√	√	√	√	√	√		
INTDMA0	DMAIF0	DMAMK0	DMAPR00, DMAPR10	√	√	√	√	√	√	√	√	√	√	√	√	√	√			
INTDMA1	DMAIF1	DMAMK1	DMAPR01, DMAPR11	√	√	√	√	√	√	√	√	√	√	√	√	√	√			
INTST0 <sup>Note 4</sup>	STIF0 <sup>Note 4</sup>	STMK0 <sup>Note 4</sup>	STPR00, STPR10 <sup>Note 4</sup>	√	√	√	√	√	√	√	√	√	√	√	√	√	√			
INTCSI00 <sup>Note 4</sup>	CSIF00 <sup>Note 4</sup>	CSIMK00 <sup>Note 4</sup>	CSIPR000, CSIPR100 <sup>Note 4</sup>	√	√	√	√	√	√	√	√	√	√	√	√	√	√			
INTIIC00 <sup>Note 4</sup>	IICIF00 <sup>Note 4</sup>	IICMK00 <sup>Note 4</sup>	IICPR000, IICPR100 <sup>Note 4</sup>	√	√	√	√	√	√	√	√	√	√	√	√	√	√			
INTSR0 <sup>Note 5</sup>	SRIF0 <sup>Note 5</sup>	SRMK0 <sup>Note 5</sup>	SRPR00, SRPR10 <sup>Note 5</sup>	√	√	√	√	√	√	√	√	√	√	√	√	√	√			
INTCSI01 <sup>Note 5</sup>	CSIF01 <sup>Note 5</sup>	CSIMK01 <sup>Note 5</sup>	CSIPR001, CSIPR101 <sup>Note 5</sup>	√	√	√	√	√	√	√	√	√	√	√	√	√	√			
INTIIC01 <sup>Note 5</sup>	IICIF01 <sup>Note 5</sup>	IICMK01 <sup>Note 5</sup>	IICPR001, IICPR101 <sup>Note 5</sup>	√	√	√	√	√	√	√	√	√	√	√	√	√	√			
INTSRE0 <sup>Note 6</sup>	SREIF0 <sup>Note 6</sup>	SREMK0 <sup>Note 6</sup>	SREPR00, SREPR10 <sup>Note 6</sup>	√	√	√	√	√	√	√	√	√	√	√	√	√	√			
INTTM01H <sup>Note 6</sup>	TMIF01H <sup>Note 6</sup>	TMMK01H <sup>Note 6</sup>	TMPR001H, TMPR101H <sup>Note 6</sup>	√	√	√	√	√	√	√	√	√	√	√	√	√	√			

- Notes**
- Do not use UART2, CSI20, and IIC20 at the same time because they share flags for the interrupt request sources. If one of the interrupt sources INTST2, INTCSI20, and INTIIC20 is generated, bit 0 of the IF0H register is set to 1. Bit 0 of the MK0H, PR00H, and PR10H registers supports these three interrupt sources.
  - Do not use UART2, CSI21, and IIC21 at the same time because they share flags for the interrupt request sources. If one of the interrupt sources INTSR2, INTCSI21, and INTIIC21 is generated, bit 1 of the IF0H register is set to 1. Bit 1 of the MK0H, PR00H, and PR10H registers supports these three interrupt sources.
  - Do not use UART2 and channel 1 of TAU1 (at 8-bit timer operation) at the same time because they share flags for the interrupt request sources. If one of the interrupt sources INTSRE2 and INTTM11H is generated, bit 2 of the IF0H register is set to 1. Bit 2 of the MK0H, PR00H, and PR10H registers supports these two interrupt sources.
  - Do not use UART0, CSI00, and IIC00 at the same time because they share flags for the interrupt request sources. If one of the interrupt sources INTST0, INTCSI00, and INTIIC00 is generated, bit 5 of the IF0H register is set to 1. Bit 5 of the MK0H, PR00H, and PR10H registers supports these three interrupt sources.
  - Do not use UART0, CSI01, and IIC01 at the same time because they share flags for the interrupt request sources. If one of the interrupt sources INTSR0, INTCSI01, and INTIIC01 is generated, bit 6 of the IF0H register is set to 1. Bit 6 of the MK0H, PR00H, and PR10H registers supports these three interrupt sources.
  - Do not use UART0 and channel 1 of TAU0 (at 8-bit timer operation) at the same time because they share flags for the interrupt request sources. If one of the interrupt sources INTSRE0 and INTTM01H is generated, bit 7 of the IF0H register is set to 1. Bit 7 of the MK0H, PR00H, and PR10H registers supports these two interrupt sources.

Table 16-2. Flags Corresponding to Interrupt Request Sources (3/4)

Interrupt Source	Interrupt Request Flag		Interrupt Mask Flag		Priority Specification Flag		18-pin	100-pin	80-pin	64-pin	52-pin	48-pin	40, 44-pin	36-pin	30, 32-pin	24, 25-pin	20-pin			
		Register		Register		Register														
INTST1 <sup>Note 1</sup>	STIF1 <sup>Note 1</sup>	IF1L	STMK1 <sup>Note 1</sup>	MK1L	STPR01, STPR11 <sup>Note 1</sup>	PR01L, PR11L	√	√	√	√	√	√	√	√	√	√	√			
INTCSI10 <sup>Note 1</sup>	CSIIF10 <sup>Note 1</sup>		CSIMK10 <sup>Note 1</sup>		CSIPR010, CSIPR110 <sup>Note 1</sup>		√	√	√	√	–	–	–	–	–	–	–	–	–	
INTIIC10 <sup>Note 1</sup>	IICIF10 <sup>Note 1</sup>		IICMK10 <sup>Note 1</sup>		IICPR010, IICPR110 <sup>Note 1</sup>		√	√	√	√	–	–	–	–	–	–	–	–	–	
INTSR1 <sup>Note 2</sup>	SRIF1 <sup>Note 2</sup>		SRMK1 <sup>Note 2</sup>		SRPR01, SRPR11 <sup>Note 2</sup>		√	√	√	√	√	√	√	√	√	√	√	√	√	√
INTCSI11 <sup>Note 2</sup>	CSIIF11 <sup>Note 2</sup>		CSIMK11 <sup>Note 2</sup>		CSIPR011, CSIPR111 <sup>Note 2</sup>		√	√	√	√	√	√	√	√	√	√	√	√	√	√
INTIIC11 <sup>Note 2</sup>	IICIF11 <sup>Note 2</sup>		IICMK11 <sup>Note 2</sup>		IICPR011, IICPR111 <sup>Note 2</sup>		√	√	√	√	√	√	√	√	√	√	√	√	√	√
INTSRE1 <sup>Note 3</sup>	SREIF1 <sup>Note 3</sup>		SREMK1 <sup>Note 3</sup>		SREPR01, SREPR11 <sup>Note 3</sup>		√	√	√	√	√	√	√	√	√	√	√	√	√	√
INTTM03H <sup>Note 3</sup>	TMIF03H <sup>Note 3</sup>		TMMK03H <sup>Note 3</sup>		TMPR003H, TMPR103H <sup>Note 3</sup>		√	√	√	√	√	√	√	√	√	√	√	√	√	√
INTIICA0	IICAIF0		IICAMK0		IICAPR00, IICAPR10		√	√	√	√	√	√	√	√	√	√	√	√	√	–
INTTM00	TMIF00		TMMK00		TMPR000, TMPR100		√	√	√	√	√	√	√	√	√	√	√	√	√	√
INTTM01	TMIF01	TMMK01	TMPR001, TMPR101	√	√	√	√	√	√	√	√	√	√	√	√	√	√			
INTTM02	TMIF02	TMMK02	TMPR002, TMPR102	√	√	√	√	√	√	√	√	√	√	√	√	√	√			
INTTM03	TMIF03	TMMK03	TMPR003, TMPR103	√	√	√	√	√	√	√	√	√	√	√	√	√	√			
INTAD	ADIF	IF1H	ADMK	MK1H	ADPR0, ADPR1	PR01H, PR11H	√	√	√	√	√	√	√	√	√	√	√			
INTRTC	RTCIF		RTCMK		RTCPR0, RTCPR1		√	√	√	√	√	√	√	√	√	√	√	√	√	
INTIT	ITIF		ITMK		ITPR0, ITPR1		√	√	√	√	√	√	√	√	√	√	√	√	√	
INTKR	KRIF		KRMK		KRPR0, KRPR1		√	√	√	√	√	√	√	√	–	–	–	–	–	
INTST3 <sup>Note 4</sup>	STIF3 <sup>Note 4</sup>		STMK3 <sup>Note 4</sup>		STPR03, STPR13 <sup>Note 4</sup>		√	√	√	–	–	–	–	–	–	–	–	–	–	
INTCSI30 <sup>Note 4</sup>	CSIIF30 <sup>Note 4</sup>		CSIMK30 <sup>Note 4</sup>		CSIPR030, CSIPR130 <sup>Note 4</sup>		√	√	√	–	–	–	–	–	–	–	–	–	–	
INTIIC30 <sup>Note 4</sup>	IICIF30 <sup>Note 4</sup>		IICMK30 <sup>Note 4</sup>		IICPR030, IICPR130 <sup>Note 4</sup>		√	√	√	–	–	–	–	–	–	–	–	–	–	
INTSR3 <sup>Note 5</sup>	SRIF3 <sup>Note 5</sup>		SRMK3 <sup>Note 5</sup>		SRPR03, SRPR13 <sup>Note 5</sup>		√	√	√	–	–	–	–	–	–	–	–	–	–	
INTCSI31 <sup>Note 5</sup>	CSIIF31 <sup>Note 5</sup>		CSIMK31 <sup>Note 5</sup>		CSIPR031, CSIPR131 <sup>Note 5</sup>		√	√	√	–	–	–	–	–	–	–	–	–	–	
INTIIC31 <sup>Note 5</sup>	IICIF31 <sup>Note 5</sup>		IICMK31 <sup>Note 5</sup>		IICPR031, IICPR131 <sup>Note 5</sup>		√	√	√	–	–	–	–	–	–	–	–	–	–	
INTTM13	TMIF13	TMMK13	TMPR013, TMPR113	√	√	√	–	–	–	–	–	–	–	–	–	–	–			
INTTM04	TMIF04	TMMK04	TMPR004, TMPR104	√	√	√	√	√	√	√	√	√	√	√	√	√	√			

- Notes**
- Do not use UART1, CSI10, and IIC10 at the same time because they share flags for the interrupt request sources. If one of the interrupt sources INTST1, INTCSI10, and INTIIC10 is generated, bit 0 of the IF1L register is set to 1. Bit 0 of the MK1L, PR01L, and PR11L registers supports these three interrupt sources.
  - Do not use UART1, CSI11, and IIC11 at the same time because they share flags for the interrupt request sources. If one of the interrupt sources INTSR1, INTCSI11, and INTIIC11 is generated, bit 1 of the IF1L register is set to 1. Bit 1 of the MK1L, PR01L, and PR11L registers supports these three interrupt sources.
  - Do not use UART1 and channel 3 of TAU0 (at 8-bit timer operation) at the same time because they share flags for the interrupt request sources. If one of the interrupt sources INTSRE1 and INTTM03H is generated, bit 2 of the IF1L register is set to 1. Bit 2 of the MK1L, PR01L, and PR11L registers supports these two interrupt sources.
  - Do not use UART3, CSI30, and IIC30 at the same time because they share flags for the interrupt request sources. If one of the interrupt sources INTST3, INTCSI30, and INTIIC30 is generated, bit 4 of the IF1H register is set to 1. Bit 4 of the MK1H, PR01H, and PR11H registers supports these three interrupt sources.
  - Do not use UART3, CSI31, and IIC31 at the same time because they share flags for the interrupt request sources. If one of the interrupt sources INTSR3, INTCSI31, and INTIIC31 is generated, bit 5 of the IF1H register is set to 1. Bit 5 of the MK1H, PR01H, and PR11H registers supports these three interrupt sources.

Table 16-2. Flags Corresponding to Interrupt Request Sources (4/4)

Interrupt Source	Interrupt Request Flag		Interrupt Mask Flag		Priority Specification Flag		18-pin	100-pin	80-pin	64-pin	52-pin	48-pin	40, 44-pin	36-pin	30, 32-pin	24, 25-pin	20-pin		
	Register	Register	Register	Register															
INTTM05	TMIF05	IF2L	TMMK05	MK2L	TMPR005, TMPR105	PR02L, PR12L	√	√	√	√	√	√	√	√	√	√	√		
INTTM06	TMIF06		TMMK06		TMPR006, TMPR106		√	√	√	√	√	√	√	√	√	√	√	√	√
INTTM07	TMIF07		TMMK07		TMPR007, TMPR107		√	√	√	√	√	√	√	√	√	√	√	√	√
INTP6	PIF6		PMK6		PPR06, PPR16		√	√	√	√	√	√	–	–	–	–	–	–	–
INTP7	PIF7		PMK7		PPR07, PPR17		√	√	√	√	–	–	–	–	–	–	–	–	–
INTP8	PIF8		PMK8		PPR08, PPR18		√	√	√	√	√	√	–	–	–	–	–	–	–
INTP9	PIF9		PMK9		PPR09, PPR19		√	√	√	√	√	√	–	–	–	–	–	–	–
INTP10	PIF10		PMK10		PPR010, PPR110		√	√	√	√	√	√	–	–	–	–	–	–	–
INTP11	PIF11	IF2H	PMK11	MK2H	PPR011, PPR111	PR02H, PR12H	√	√	√	√	√	–	–	–	–	–	–		
INTTM10	TMIF10		TMMK10		TMPR010, TMPR110		√	√	√	–	–	–	–	–	–	–	–	–	
INTTM11	TMIF11		TMMK11		TMPR011, TMPR111		√	√	√	–	–	–	–	–	–	–	–	–	
INTTM12	TMIF12		TMMK12		TMPR012, TMPR112		√	√	√	–	–	–	–	–	–	–	–	–	
INTSRE3 <sup>Note</sup>	SREIF3 <sup>Note</sup>		SREMK3 <sup>Note</sup>		SREPR03, SREPR13 <sup>Note</sup>		√	√	√	–	–	–	–	–	–	–	–	–	–
INTTM13H <sup>Note</sup>	TMIF13H <sup>Note</sup>		TMMK13H <sup>Note</sup>		TMPR013H, TMPR113H <sup>Note</sup>		√	√	√	–	–	–	–	–	–	–	–	–	–
INTMD	MDIF		MDMK		MDPR0, MDPR1		√	√	√	√	√	√	√	√	√	√	√	√	√
INTIICA1	IICAF1		IICAMK1		IICAPR01, IICAPR11		√	√	√	–	–	–	–	–	–	–	–	–	–
INTFL	FLIF	FLMK	FLPR0, FLPR1	√	√	√	√	√	√	√	√	√	√	√	√	√			
INTDMA2	DMAIF2	IF3L	DMAMK2	MK3L	DMAPR02, DMAPR12	PR03L, PR13L	√	√	√	–	–	–	–	–	–	–	–		
INTDMA3	DMAIF3		DMAMK3		DMAPR03, DMAPR13		√	√	√	–	–	–	–	–	–	–	–	–	
INTTM14	TMIF14		TMMK14		TMPR014, TMPR114		√	–	–	–	–	–	–	–	–	–	–	–	
INTTM15	TMIF15		TMMK15		TMPR015, TMPR115		√	–	–	–	–	–	–	–	–	–	–	–	
INTTM16	TMIF16		TMMK16		TMPR016, TMPR116		√	–	–	–	–	–	–	–	–	–	–	–	
INTTM17	TMIF17		TMMK17		TMPR017, TMPR117		√	–	–	–	–	–	–	–	–	–	–	–	

**Note** Do not use UART3 and channel 3 of TAU1 (at 8-bit timer operation) at the same time because they share flags for the interrupt request sources. If one of the interrupt sources INTSRE3 and INTTM13H is generated, bit 4 of the IF2H register is set to 1. Bit 4 of the MK2H, PR02H, and PR12H registers supports these two interrupt sources.

**(1) Interrupt request flag registers (IF0L, IF0H, IF1L, IF1H, IF2L, IF2H, IF3L)**

The interrupt request flags are set to 1 when the corresponding interrupt request is generated or an instruction is executed. They are cleared to 0 when an instruction is executed upon acknowledgment of an interrupt request or upon reset signal generation.

When an interrupt is acknowledged, the interrupt request flag is automatically cleared and then the interrupt routine is entered.

The IF0L, IF0H, IF1L, IF1H, IF2L, IF2H, and IF3L registers can be set by a 1-bit or 8-bit memory manipulation instruction. When the IF0L and IF0H registers, the IF1L and IF1H registers, and the IF2L and IF2H registers are combined to form 16-bit registers IF0, IF1, and IF2, they can be set by a 16-bit memory manipulation instruction.

Reset signal generation clears these registers to 00H.

**Remark** If an instruction that writes data to this register is executed, the number of instruction execution clocks increases by 2 clocks.

**Figure 16-2. Format of Interrupt Request Flag Registers (IF0L, IF0H, IF1L, IF1H, IF2L, IF2H, IF3L) (128-pin) (1/2)**

Address: FFFE0H After reset: 00H R/W

Symbol	<7>	<6>	<5>	<4>	<3>	<2>	<1>	<0>
IF0L	PIF5	PIF4	PIF3	PIF2	PIF1	PIF0	LVIIIF	WDTIIF

Address: FFFE1H After reset: 00H R/W

Symbol	<7>	<6>	<5>	<4>	<3>	<2>	<1>	<0>
IF0H	SREIF0 TMIF01H	SRIF0 CSIIIF01 IICIF01	STIF0 CSIIIF00 IICIF00	DMAIF1	DMAIF0	SREIF2 TMIF11H	SRIF2 CSIIIF21 IICIF21	STIF2 CSIIIF20 IICIF20

Address: FFFE2H After reset: 00H R/W

Symbol	<7>	<6>	<5>	<4>	<3>	<2>	<1>	<0>
IF1L	TMIF03	TMIF02	TMIF01	TMIF00	IICAIF0	SREIF1 TMIF03H	SRIF1 CSIIIF11 IICIF11	STIF1 CSIIIF10 IICIF10

Address: FFFE3H After reset: 00H R/W

Symbol	<7>	<6>	<5>	<4>	<3>	<2>	<1>	<0>
IF1H	TMIF04	TMIF13	SRIF3 CSIIIF31 IICIF31	STIF3 CSIIIF30 IICIF30	KRIF	ITIF	RTCIF	ADIF

Address: FFFD0H After reset: 00H R/W

Symbol	<7>	<6>	<5>	<4>	<3>	<2>	<1>	<0>
IF2L	PIF10	PIF9	PIF8	PIF7	PIF6	TMIF07	TMIF06	TMIF05

**Figure 16-2. Format of Interrupt Request Flag Registers (IF0L, IF0H, IF1L, IF1H, IF2L, IF2H, IF3L) (128-pin) (2/2)**

Address: FFFD1H After reset: 00H R/W

Symbol	<7>	<6>	<5>	<4>	<3>	<2>	<1>	<0>
IF2H	FLIF	IICAIF1	MDIF	SREIF3 TMIF13H	TMIF12	TMIF11	TMIF10	PIF11

Address: FFFD2H After reset: 00H R/W

Symbol	7	6	<5>	<4>	<3>	<2>	<1>	<0>
IF3L	0	0	TMIF17	TMIF16	TMIF15	TMIF14	DMAIF3	DMAIF2

XXIFX	Interrupt request flag
0	No interrupt request signal is generated
1	Interrupt request is generated, interrupt request status

- Cautions**
1. The above is the bit layout for the 128-pin. The available bits differ depending on the product. For details about the bits available for each product, see Table 16-2. Be sure to clear bits that are not available to 0.
  2. When operating a timer, serial interface, or A/D converter after standby release, operate it once after clearing the interrupt request flag. An interrupt request flag may be set by noise.
  3. When manipulating a flag of the interrupt request flag register, use a 1-bit memory manipulation instruction (CLR1). When describing in C language, use a bit manipulation instruction such as “IF0L.0 = 0;” or “\_asm(“clr1 IF0L, 0”);” because the compiled assembler must be a 1-bit memory manipulation instruction (CLR1).

If a program is described in C language using an 8-bit memory manipulation instruction such as “IF0L &= 0xfe;” and compiled, it becomes the assembler of three instructions.

```
mov a, IF0L
and a, #0FEH
mov IF0L, a
```

In this case, even if the request flag of the another bit of the same interrupt request flag register (IF0L) is set to 1 at the timing between “mov a, IF0L” and “mov IF0L, a”, the flag is cleared to 0 at “mov IF0L, a”. Therefore, care must be exercised when using an 8-bit memory manipulation instruction in C language.

**(2) Interrupt mask flag registers (MK0L, MK0H, MK1L, MK1H, MK2L, MK2H, MK3L)**

The interrupt mask flags are used to enable/disable the corresponding maskable interrupt servicing. The MK0L, MK0H, MK1L, MK1H, MK2L, MK2H, and MK3L registers can be set by a 1-bit or 8-bit memory manipulation instruction. When the MK0L and MK0H registers, the MK1L and MK1H registers, and the MK2L and MK2H registers are combined to form 16-bit registers MK0, MK1, and MK2, they can be set by a 16-bit memory manipulation instruction. Reset signal generation sets these registers to FFH.

**Remark** If an instruction that writes data to this register is executed, the number of instruction execution clocks increases by 2 clocks.

**Figure 16-3. Format of Interrupt Mask Flag Registers (MK0L, MK0H, MK1L, MK1H, MK2L, MK2H, MK3L)(128-pin)**

Address: FFFE4H After reset: FFH R/W

Symbol	<7>	<6>	<5>	<4>	<3>	<2>	<1>	<0>
MK0L	PMK5	PMK4	PMK3	PMK2	PMK1	PMK0	LVIMK	WDTIMK

Address: FFFE5H After reset: FFH R/W

Symbol	<7>	<6>	<5>	<4>	<3>	<2>	<1>	<0>
MK0H	SREMK0 TMMK01H	SRMK0 CSIMK01 IICMK01	STMK0 CSIMK00 IICMK00	DMAMK1	DMAMK0	SREMK2 TMMK11H	SRMK2 CSIMK21 IICMK21	STMK2 CSIMK20 IICMK20

Address: FFFE6H After reset: FFH R/W

Symbol	<7>	<6>	<5>	<4>	<3>	<2>	<1>	<0>
MK1L	TMMK03	TMMK02	TMMK01	TMMK00	IICAMK0	SREMK1 TMMK03H	SRMK1 CSIMK11 IICMK11	STMK1 CSIMK10 IICMK10

Address: FFFE7H After reset: FFH R/W

Symbol	<7>	6	5	4	<3>	<2>	<1>	<0>
MK1H	TMMK04	TMMK13	SRMK3 CSIMK31 IICMK31	STMK3 CSIMK30 IICMK30	KRMK	ITMK	RTCMK	ADMK

Address: FFFD4H After reset: FFH R/W

Symbol	<7>	<6>	<5>	<4>	<3>	<2>	<1>	<0>
MK2L	PMK10	PMK9	PMK8	PMK7	PMK6	TMMK07	TMMK06	TMMK05

Address: FFFD5H After reset: FFH R/W

Symbol	<7>	<6>	<5>	<4>	<3>	<2>	<1>	<0>
MK2H	FLMK	IICAMK1	MDMK	SREMK3 TMMK13H	TMMK12	TMMK11	TMMK10	PMK11

Address: FFFD6H After reset: FFH R/W

Symbol	7	6	<5>	<4>	<3>	<2>	<1>	<0>
MK3L	1	1	TMMK17	TMMK16	TMMK15	TMMK14	DMAMK3	DMAMK2

XXMKX	Interrupt servicing control
0	Interrupt servicing enabled
1	Interrupt servicing disabled

**Caution** The above is the bit layout for the 128-pin. The available bits differ depending on the product. For details about the bits available for each product, see Table 16-2. Be sure to set bits that are not available to 1.

**(3) Priority specification flag registers (PR00L, PR00H, PR01L, PR01H, PR02L, PR02H, PR03L, PR10L, PR10H, PR11L, PR11H, PR12L, PR12H, PR13L)**

The priority specification flag registers are used to set the corresponding maskable interrupt priority level.

A priority level is set by using the PR0xy and PR1xy registers in combination (xy = 0L, 0H, 1L, 1H, 2L, or 2H).

The PR00L, PR00H, PR01L, PR01H, PR02L, PR02H, PR03L, PR10L, PR10H, PR11L, PR11H, PR12L, PR12H, and the PR13L registers can be set by a 1-bit or 8-bit memory manipulation instruction. If the PR00L and PR00H registers, the PR01L and PR01H registers, the PR02L and PR02H registers, the PR10L and PR10H registers, the PR11L and PR11H registers, and the PR12L and PR12H registers are combined to form 16-bit registers PR00, PR01, PR02, PR10, PR11, and PR12, they can be set by a 16-bit memory manipulation instruction.

Reset signal generation sets these registers to FFH.

**Remark** If an instruction that writes data to this register is executed, the number of instruction execution clocks increases by 2 clocks.

**Figure 16-4. Format of Priority Specification Flag Registers (PR00L, PR00H, PR01L, PR01H, PR02L, PR02H, PR03L, PR10L, PR10H, PR11L, PR11H, PR12L, PR12H, PR13L) (128-pin) (1/3)**

Address: FFFE8H After reset: FFH R/W

Symbol	<7>	<6>	<5>	<4>	<3>	<2>	<1>	<0>
PR00L	PPR05	PPR04	PPR03	PPR02	PPR01	PPR00	LVIPR0	WDTIPR0

Address: FFFECH After reset: FFH R/W

Symbol	<7>	<6>	<5>	<4>	<3>	<2>	<1>	<0>
PR10L	PPR15	PPR14	PPR13	PPR12	PPR11	PPR10	LVIPR1	WDTIPR1

Address: FFFE9H After reset: FFH R/W

Symbol	<7>	<6>	<5>	<4>	<3>	<2>	<1>	<0>
PR00H	SREPR00 TMPR001H	SRPR00 CSIPR001 IICPR001	STPR00 CSIPR000 IICPR000	DMAPR01	DMAPR00	SREPR02 TMPR011H	SRPR02 CSIPR021 IICPR021	STPR02 CSIPR020 IICPR020

Address: FFFEDH After reset: FFH R/W

Symbol	<7>	<6>	<5>	<4>	<3>	<2>	<1>	<0>
PR10H	SREPR10 TMPR101H	SRPR10 CSIPR101 IICPR101	STPR10 CSIPR100 IICPR100	DMAPR11	DMAPR10	SREPR12 TMPR111H	SRPR12 CSIPR121 IICPR121	STPR12 CSIPR120 IICPR120

Address: FFFEAH After reset: FFH R/W

Symbol	<7>	<6>	<5>	<4>	<3>	<2>	<1>	<0>
PR01L	TMPR003	TMPR002	TMPR001	TMPR000	IICAPR00	SREPR01 TMPR003H	SRPR01 CSIPR011 IICPR011	STPR01 CSIPR010 IICPR010

Address: FFFEEH After reset: FFH R/W

Symbol	<7>	<6>	<5>	<4>	<3>	<2>	<1>	<0>
PR11L	TMPR103	TMPR102	TMPR101	TMPR100	IICAPR10	SREPR11 TMPR103H	SRPR11 CSIPR111 IICPR111	STPR11 CSIPR110 IICPR110

**Figure 16-4. Format of Priority Specification Flag Registers (PR00L, PR00H, PR01L, PR01H, PR02L, PR02H, PR03L, PR10L, PR10H, PR11L, PR11H, PR12L, PR12H, PR13L) (128-pin) (2/3)**

Address: FFFEBH After reset: FFH R/W

Symbol	<7>	<6>	<5>	<4>	<3>	<2>	<1>	<0>
PR01H	TMPR004	TMPR013	SRPR03 CSIPR031 IICPR031	STPR03 CSIPR030 IICPR030	KRPR0	ITPR0	RTCPR0	ADPR0

Address: FFFE7H After reset: FFH R/W

Symbol	<7>	<6>	<5>	<4>	<3>	<2>	<1>	<0>
PR11H	TMPR104	TMPR113	SRPR13 CSIPR131 IICPR131	STPR13 CSIPR130 IICPR130	KRPR1	ITPR1	RTCPR1	ADPR1

Address: FFFD8H After reset: FFH R/W

Symbol	<7>	<6>	<5>	<4>	<3>	<2>	<1>	<0>
PR02L	PPR010	PPR09	PPR08	PPR07	PPR06	TMPR007	TMPR006	TMPR005

Address: FFFDCH After reset: FFH R/W

Symbol	<7>	<6>	<5>	<4>	<3>	<2>	<1>	<0>
PR12L	PPR110	PPR19	PPR18	PPR17	PPR16	TMPR107	TMPR106	TMPR105

Address: FFFD9H After reset: FFH R/W

Symbol	<7>	6	<5>	4	3	2	1	<0>
PR02H	FLPR0	IICAPR01	MDPR0	SREPR03 TMPR013H	TMPR012	TMPR011	TMPR010	PPR011

Address: FFFDDH After reset: FFH R/W

Symbol	<7>	6	<5>	4	3	2	1	<0>
PR12H	FLPR1	IICAPR11	MDPR1	SREPR13 TMPR113H	TMPR112	TMPR111	TMPR110	PPR111



**Figure 16-4. Format of Priority Specification Flag Registers (PR00L, PR00H, PR01L, PR01H, PR02L, PR02H, PR03L, PR10L, PR10H, PR11L, PR11H, PR12L, PR12H, PR13L) (128-pin) (3/3)**

Address: FFFDAH After reset: FFH R/W

Symbol	7	6	<5>	<4>	<3>	<2>	<1>	<0>
PR03L	1	1	TMPR017	TMPR016	TMPR015	TMPR014	DMAPR03	DMAPR02

Address: FFFDEH After reset: FFH R/W

Symbol	7	6	<5>	<4>	<3>	<2>	<1>	<0>
PR13L	1	1	TMPR117	TMPR116	TMPR115	TMPR114	DMAPR13	DMAPR12

XXPR1X	XXPR0X	Priority level selection
0	0	Specify level 0 (high priority level)
0	1	Specify level 1
1	0	Specify level 2
1	1	Specify level 3 (low priority level)

**Caution** The above is the bit layout for the 128-pin. The available bits differ depending on the product. For details about the bits available for each product, see Table 16-2. Be sure to set bits that are not available to 1.

**(4) External interrupt rising edge enable registers (EGP0, EGP1), external interrupt falling edge enable registers (EGN0, EGN1)**

These registers specify the valid edge for INTP0 to INTP11.

The EGP0, EGP1, EGN0, and EGN1 registers can be set by a 1-bit or 8-bit memory manipulation instruction.

Reset signal generation clears these registers to 00H.

**Figure 16-5. Format of External Interrupt Rising Edge Enable Registers (EGP0, EGP1) and External Interrupt Falling Edge Enable Registers (EGN0, EGN1) (128-pin)**

Address: FFF38H After reset: 00H R/W

Symbol	7	6	5	4	3	2	1	0
EGP0	EGP7	EGP6	EGP5	EGP4	EGP3	EGP2	EGP1	EGP0

Address: FFF39H After reset: 00H R/W

Symbol	7	6	5	4	3	2	1	0
EGN0	EGN7	EGN6	EGN5	EGN4	EGN3	EGN2	EGN1	EGN0

Address: FFF3AH After reset: 00H R/W

Symbol	7	6	5	4	3	2	1	0
EGP1	0	0	0	0	EGP11	EGP10	EGP9	EGP8

Address: FFF3BH After reset: 00H R/W

Symbol	7	6	5	4	3	2	1	0
EGN1	0	0	0	0	EGN11	EGN10	EGN9	EGN8

EGPn	EGNn	INTPn pin valid edge selection (n = 0 to 11)
0	0	Edge detection disabled
0	1	Falling edge
1	0	Rising edge
1	1	Both rising and falling edges

Table 16-3 shows the ports corresponding to the EGPn and EGNn bits.

Table 16-3. Ports Corresponding to EGPn and EGNn bits

Detection Enable Bit		Edge Detection Port	Interrupt Request Signal	64, 80, 100, 128-pin	52-pin	48-pin	30, 32, 36, 40, 44-pin	24, 25-pin	20-pin
EGP0	EGN0	P137	INTP0	√	√	√	√	√	√
EGP1	EGN1	P50(P46 <sup>Note</sup> )	INTP1	√	√	√	√	√	–
EGP2	EGN2	P51(P47 <sup>Note</sup> )	INTP2	√	√	√	√	–	–
EGP3	EGN3	P30	INTP3	√	√	√	√	√	√
EGP4	EGN4	P31	INTP4	√	√	√	√	√	–
EGP5	EGN5	P16	INTP5	√	√	√	√	√	√
EGP6	EGN6	P140	INTP6	√	√	√	–	–	–
EGP7	EGN7	P141	INTP7	√	–	–	–	–	–
EGP8	EGN8	P74	INTP8	√	√	√	–	–	–
EGP9	EGN9	P75	INTP9	√	√	√	–	–	–
EGP10	EGN10	P76	INTP10	√	√	–	–	–	–
EGP11	EGN11	P77	INTP11	√	√	–	–	–	–

**Note** 100-pin and 128-pin products.

**Caution** Select the port mode by clearing the EGPn and EGNn bits to 0 because an edge may be detected when the external interrupt function is switched to the port function.

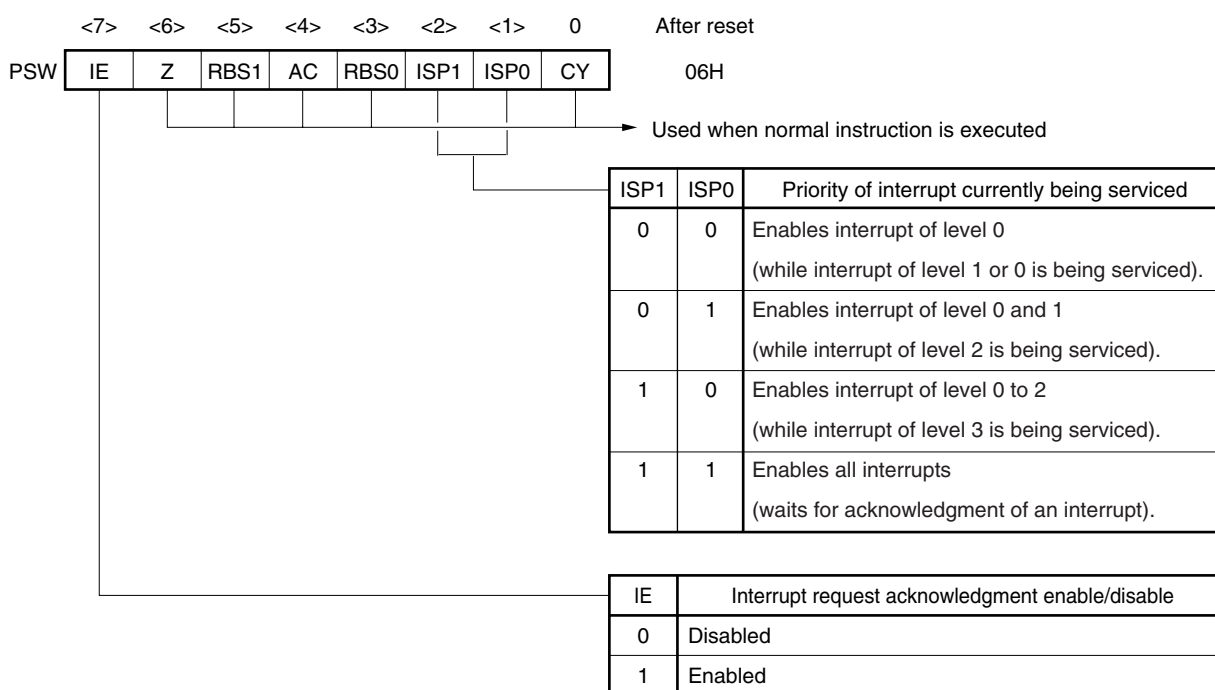
**Remark** n = 0 to 11

**(5) Program status word (PSW)**

The program status word is a register used to hold the instruction execution result and the current status for an interrupt request. The IE flag that sets maskable interrupt enable/disable and the ISP0 and ISP1 flags that controls multiple interrupt servicing are mapped to the PSW.

Besides 8-bit read/write, this register can carry out operations using bit manipulation instructions and dedicated instructions (EI and DI). When a vectored interrupt request is acknowledged, if the BRK instruction is executed, the contents of the PSW are automatically saved into a stack and the IE flag is reset to 0. If a maskable interrupt request is acknowledged, the contents of the priority specification flag of the acknowledged interrupt are transferred to the ISP0 and ISP1 flags. The PSW contents are also saved into the stack with the PUSH PSW instruction. They are restored from the stack with the RETI, RETB, and POP PSW instructions. Reset signal generation sets PSW to 06H.

**Figure 16-6. Configuration of Program Status Word**



## 16.4 Interrupt Servicing Operations

### 16.4.1 Maskable interrupt request acknowledgment

A maskable interrupt request becomes acknowledgeable when the interrupt request flag is set to 1 and the mask (MK) flag corresponding to that interrupt request is cleared to 0. A vectored interrupt request is acknowledged if interrupts are in the interrupt enabled state (when the IE flag is set to 1). However, a low-priority interrupt request is not acknowledged during servicing of a higher priority interrupt request.

The times from generation of a maskable interrupt request until vectored interrupt servicing is performed are listed in Table 16-4 below.

For the interrupt request acknowledgment timing, see **Figures 16-8** and **16-9**.

**Table 16-4. Time from Generation of Maskable Interrupt Until Servicing**

	Minimum Time	Maximum Time <sup>Note</sup>
Servicing time	9 clocks	14 clocks

**Note** If an interrupt request is generated just before the RET instruction, the wait time becomes longer.

**Remark** 1 clock:  $1/f_{CLK}$  ( $f_{CLK}$ : CPU clock)

If two or more maskable interrupt requests are generated simultaneously, the request with a higher priority level specified in the priority specification flag is acknowledged first. If two or more interrupts requests have the same priority level, the request with the highest default priority is acknowledged first.

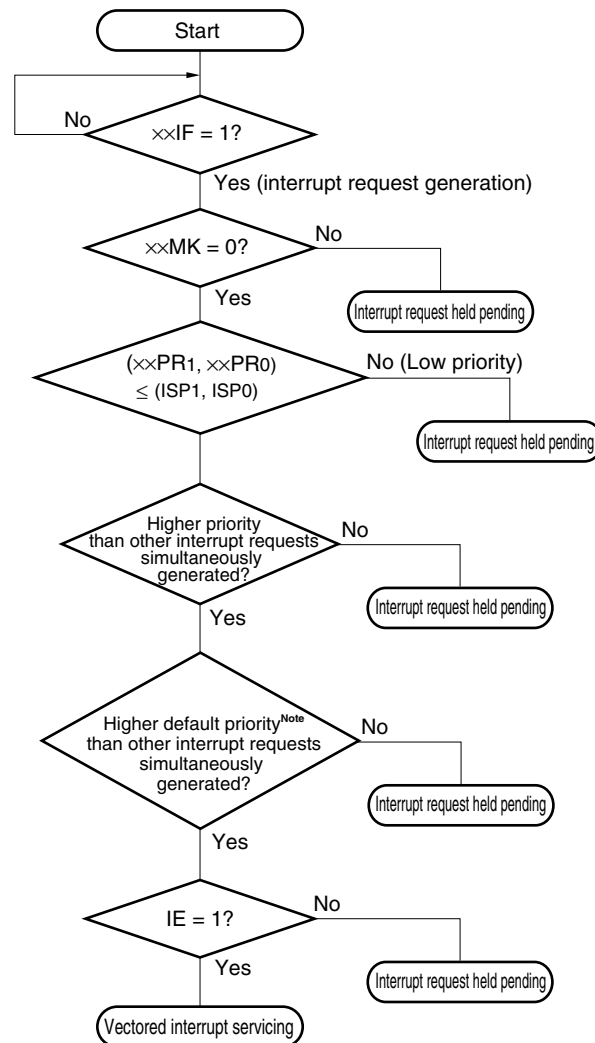
An interrupt request that is held pending is acknowledged when it becomes acknowledgeable.

Figure 16-7 shows the interrupt request acknowledgment algorithm.

If a maskable interrupt request is acknowledged, the contents are saved into the stacks in the order of PSW, then PC, the IE flag is reset (0), and the contents of the priority specification flag corresponding to the acknowledged interrupt are transferred to the ISP1 and ISP0 flags. The vector table data determined for each interrupt request is the loaded into the PC and branched.

Restoring from an interrupt is possible by using the RETI instruction.

Figure 16-7. Interrupt Request Acknowledgment Processing Algorithm



xxIF: Interrupt request flag

xxMK: Interrupt mask flag

xxPR0: Priority specification flag 0

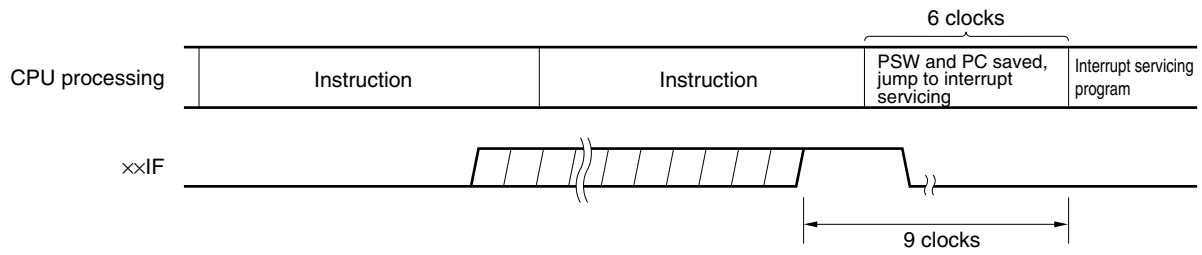
xxPR1: Priority specification flag 1

IE: Flag that controls acknowledgment of maskable interrupt request (1 = Enable, 0 = Disable)

ISP0, ISP1: Flag that indicates the priority level of the interrupt currently being serviced (see Figure 16-6)

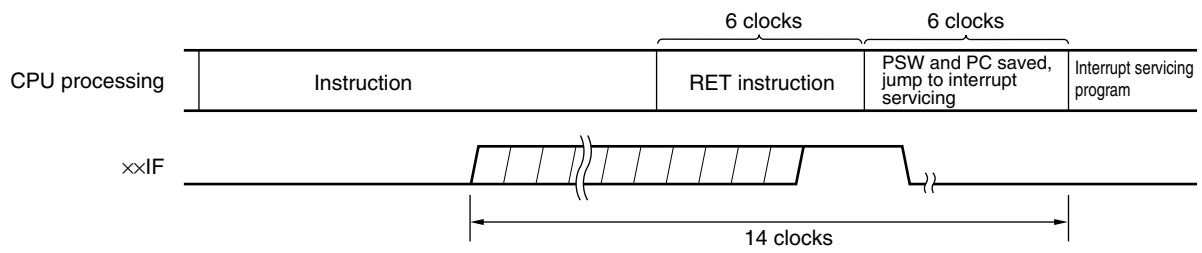
**Note** For the default priority, refer to **Table 16-1 Interrupt Source List**.

**Figure 16-8. Interrupt Request Acknowledgment Timing (Minimum Time)**



**Remark** 1 clock:  $1/f_{CLK}$  ( $f_{CLK}$ : CPU clock)

**Figure 16-9. Interrupt Request Acknowledgment Timing (Maximum Time)**



**Remark** 1 clock:  $1/f_{CLK}$  ( $f_{CLK}$ : CPU clock)

### 16.4.2 Software interrupt request acknowledgment

A software interrupt request is acknowledged by BRK instruction execution. Software interrupts cannot be disabled.

If a software interrupt request is acknowledged, the contents are saved into the stacks in the order of the program status word (PSW), then program counter (PC), the IE flag is reset (0), and the contents of the vector table (0007EH, 0007FH) are loaded into the PC and branched.

Restoring from a software interrupt is possible by using the RETB instruction.

<R> **Caution** Can not use the RETI instruction for restoring from the software interrupt.

### 16.4.3 Multiple interrupt servicing

Multiple interrupt servicing occurs when another interrupt request is acknowledged during execution of an interrupt.

Multiple interrupt servicing does not occur unless the interrupt request acknowledgment enabled state is selected (IE = 1). When an interrupt request is acknowledged, interrupt request acknowledgment becomes disabled (IE = 0). Therefore, to enable multiple interrupt servicing, it is necessary to set (1) the IE flag with the EI instruction during interrupt servicing to enable interrupt acknowledgment.

Moreover, even if interrupts are enabled, multiple interrupt servicing may not be enabled, this being subject to interrupt priority control. Two types of priority control are available: default priority control and programmable priority control. Programmable priority control is used for multiple interrupt servicing.

In the interrupt enabled state, if an interrupt request with a priority equal to or higher than that of the interrupt currently being serviced is generated, it is acknowledged for multiple interrupt servicing. If an interrupt with a priority lower than that of the interrupt currently being serviced is generated during interrupt servicing, it is not acknowledged for multiple interrupt servicing. Interrupt requests that are not enabled because interrupts are in the interrupt disabled state or because they have a lower priority are held pending. When servicing of the current interrupt ends, the pending interrupt request is acknowledged following execution of at least one main processing instruction execution.

Table 16-5 shows relationship between interrupt requests enabled for multiple interrupt servicing and Figure 16-10 shows multiple interrupt servicing examples.



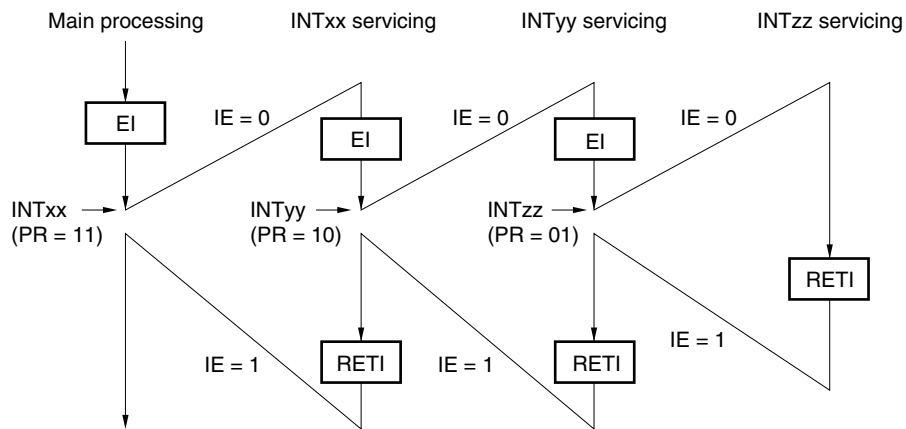
**Table 16-5. Relationship Between Interrupt Requests Enabled for Multiple Interrupt Servicing During Interrupt Servicing**

Multiple Interrupt Request Interrupt Being Serviced		Maskable Interrupt Request								Software Interrupt Request
		Priority Level 0 (PR = 00)		Priority Level 1 (PR = 01)		Priority Level 2 (PR = 10)		Priority Level 3 (PR = 11)		
		IE = 1	IE = 0	IE = 1	IE = 0	IE = 1	IE = 0	IE = 1	IE = 0	
Maskable interrupt	ISP1 = 0 ISP0 = 0	○	×	×	×	×	×	×	×	○
	ISP1 = 0 ISP0 = 1	○	×	○	×	×	×	×	×	○
	ISP1 = 1 ISP0 = 0	○	×	○	×	○	×	×	×	○
	ISP1 = 1 ISP0 = 1	○	×	○	×	○	×	○	×	○
Software interrupt		○	×	○	×	○	×	○	×	○

- Remarks**
- : Multiple interrupt servicing enabled
  - ×: Multiple interrupt servicing disabled
  - ISP0, ISP1, and IE are flags contained in the PSW.  
 ISP1 = 0, ISP0 = 0: An interrupt of level 1 or level 0 is being serviced.  
 ISP1 = 0, ISP0 = 1: An interrupt of level 2 is being serviced.  
 ISP1 = 1, ISP0 = 0: An interrupt of level 3 is being serviced.  
 ISP1 = 1, ISP0 = 1: Wait for An interrupt acknowledgment.  
 IE = 0: Interrupt request acknowledgment is disabled.  
 IE = 1: Interrupt request acknowledgment is enabled.
  - PR is a flag contained in the PR00L, PR00H, PR01L, PR01H, PR02L, PR02H, PR10L, PR10H, PR11L, PR11H, PR12L, and PR12H registers.  
 PR = 00: Specify level 0 with xxPR1x = 0, xxPR0x = 0 (higher priority level)  
 PR = 01: Specify level 1 with xxPR1x = 0, xxPR0x = 1  
 PR = 10: Specify level 2 with xxPR1x = 1, xxPR0x = 0  
 PR = 11: Specify level 3 with xxPR1x = 1, xxPR0x = 1 (lower priority level)

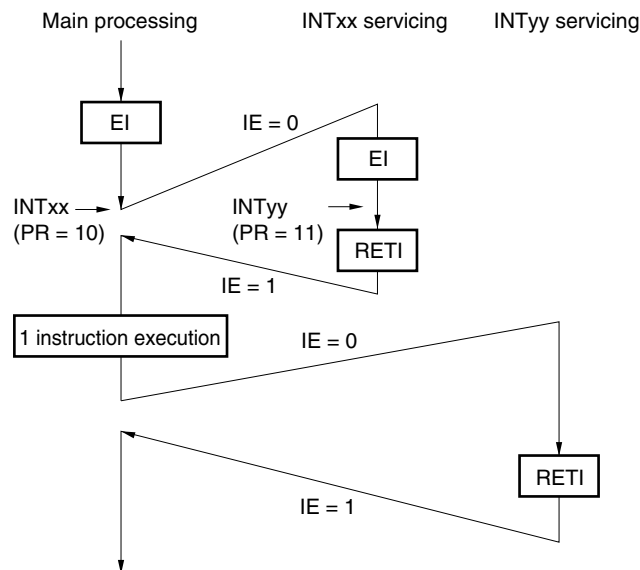
Figure 16-10. Examples of Multiple Interrupt Servicing (1/2)

**Example 1. Multiple interrupt servicing occurs twice**



During servicing of interrupt INTxx, two interrupt requests, INTyy and INTzz, are acknowledged, and multiple interrupt servicing takes place. Before each interrupt request is acknowledged, the EI instruction must always be issued to enable interrupt request acknowledgment.

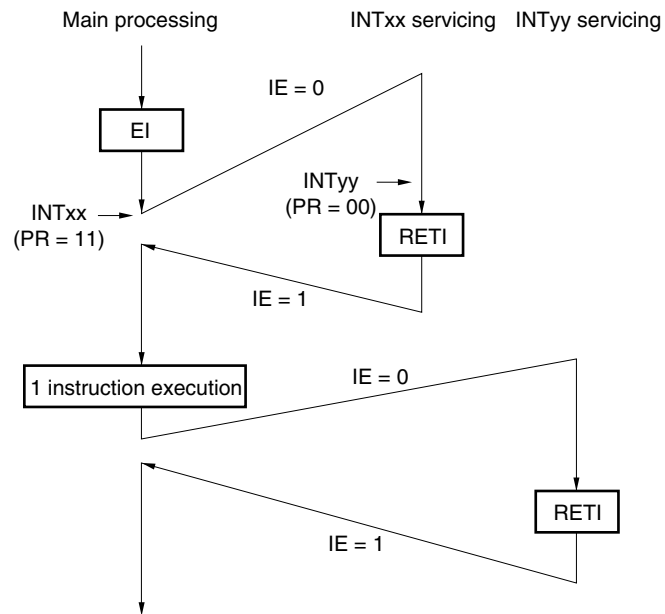
**Example 2. Multiple interrupt servicing does not occur due to priority control**



Interrupt request INTyy issued during servicing of interrupt INTxx is not acknowledged because its priority is lower than that of INTxx, and multiple interrupt servicing does not take place. The INTyy interrupt request is held pending, and is acknowledged following execution of one main processing instruction.

- PR = 00: Specify level 0 with  $\times\times PR1\times = 0, \times\times PR0\times = 0$  (higher priority level)
- PR = 01: Specify level 1 with  $\times\times PR1\times = 0, \times\times PR0\times = 1$
- PR = 10: Specify level 2 with  $\times\times PR1\times = 1, \times\times PR0\times = 0$
- PR = 11: Specify level 3 with  $\times\times PR1\times = 1, \times\times PR0\times = 1$  (lower priority level)
- IE = 0: Interrupt request acknowledgment is disabled
- IE = 1: Interrupt request acknowledgment is enabled.

Figure 16-10. Examples of Multiple Interrupt Servicing (2/2)

**Example 3. Multiple interrupt servicing does not occur because interrupts are not enabled**

Interrupts are not enabled during servicing of interrupt INTxx (EI instruction is not issued), therefore, interrupt request INTyy is not acknowledged and multiple interrupt servicing does not take place. The INTyy interrupt request is held pending, and is acknowledged following execution of one main processing instruction.

PR = 00: Specify level 0 with  $\times\times PR1\times = 0$ ,  $\times\times PR0\times = 0$  (higher priority level)

PR = 01: Specify level 1 with  $\times\times PR1\times = 0$ ,  $\times\times PR0\times = 1$

PR = 10: Specify level 2 with  $\times\times PR1\times = 1$ ,  $\times\times PR0\times = 0$

PR = 11: Specify level 3 with  $\times\times PR1\times = 1$ ,  $\times\times PR0\times = 1$  (lower priority level)

IE = 0: Interrupt request acknowledgment is disabled

IE = 1: Interrupt request acknowledgment is enabled.

#### 16.4.4 Interrupt request hold

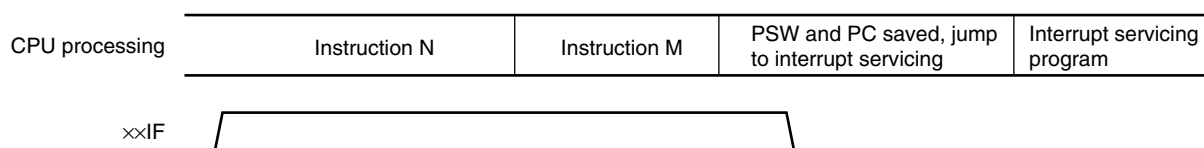
There are instructions where, even if an interrupt request is issued while the instructions are being executed, interrupt request acknowledgment is held pending until the end of execution of the next instruction. These instructions (interrupt request hold instructions) are listed below.

- MOV PSW, #byte
- MOV PSW, A
- MOV1 PSW. bit, CY
- SET1 PSW. bit
- CLR1 PSW. bit
- RETB
- RETI
- POP PSW
- BTCLR PSW. bit, \$addr20
- EI
- DI
- SKC
- SKNC
- SKZ
- SKNZ
- SKH
- SKNH
- Manipulation instructions for the IF0L, IF0H, IF1L, IF1H, IF2L, IF2H, IF3L, MK0L, MK0H, MK1L, MK1H, MK2L, MK2H, MK3L, PR00L, PR00H, PR01L, PR01H, PR02L, PR02H, PR03L, PR10L, PR10H, PR11L, PR11H, PR12L, PR12H, and PR13L registers

**Caution** The BRK instruction is not one of the above-listed interrupt request hold instructions. However, the software interrupt activated by executing the BRK instruction causes the IE flag to be cleared. Therefore, even if a maskable interrupt request is generated during execution of the BRK instruction, the interrupt request is not acknowledged.

Figure 16-11 shows the timing at which interrupt requests are held pending.

**Figure 16-11. Interrupt Request Hold**



- Remarks**
1. Instruction N: Interrupt request hold instruction
  2. Instruction M: Instruction other than interrupt request hold instruction

## CHAPTER 17 KEY INTERRUPT FUNCTION

The number of key interrupt input channels differs, depending on the product.

	20, 24, 25, 30, 32, 36-pin	40, 44-pin	48-pin	52, 64, 80, 100, 128-pin
Key interrupt input channels	–	4 ch	6 ch	8 ch

### 17.1 Functions of Key Interrupt

A key interrupt (INTKR) can be generated by setting the key return mode register (KRM) and inputting a falling edge to the key interrupt input pins (KR0 to KR7).

**Table 17-1. Assignment of Key Interrupt Detection Pins**

Flag	Description
KRM0	Controls KR0 signal in 1-bit units.
KRM1	Controls KR1 signal in 1-bit units.
KRM2	Controls KR2 signal in 1-bit units.
KRM3	Controls KR3 signal in 1-bit units.
KRM4	Controls KR4 signal in 1-bit units.
KRM5	Controls KR5 signal in 1-bit units.
KRM6	Controls KR6 signal in 1-bit units.
KRM7	Controls KR7 signal in 1-bit units.

### 17.2 Configuration of Key Interrupt

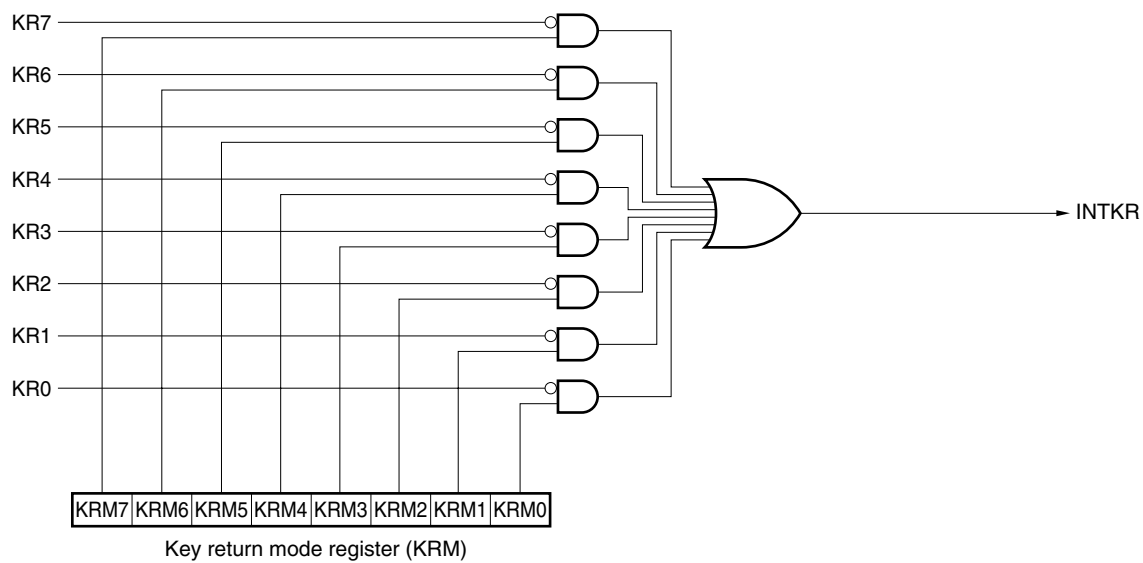
The key interrupt includes the following hardware.

**Table 17-2. Configuration of Key Interrupt**

Item	Configuration
Control register	Key return mode register (KRM)

**Remark** KR0 to KR3: 40, 44-pin products  
 KR0 to KR5: 48-pin products  
 KR0 to KR7: 52, 64, 80, 100, 128-pin products

Figure 17-1. Block Diagram of Key Interrupt



- Remark**
- KR0 to KR3: 40-, 44-pin products
  - KR0 to KR5: 48-pin products
  - KR0 to KR7: 52-, 64-, 80-, 100-, 128-pin products

### 17.3 Register Controlling Key Interrupt

#### (1) Key return mode register (KRM)

KRM register controls the KR0 to KR7 signals.

The KRM register can be set by a 1-bit or 8-bit memory manipulation instruction.

Reset signal generation clears this register to 00H.

**Figure 17-2. Format of Key Return Mode Register (KRM)**

Address: FFF37H    After reset: 00H    R/W

Symbol	7	6	5	4	3	2	1	0
KRM	KRM7	KRM6	KRM5	KRM4	KRM3	KRM2	KRM1	KRM0

KRMn	Key interrupt mode control
0	Does not detect key interrupt signal
1	Detects key interrupt signal

- Cautions**
1. If any of the KRM0 to KRM7 bits used is set to 1, set bits 0 to 7 (PU70 to PU77) of the corresponding pull-up resistor register 7 (PU7) to 1.
  2. An interrupt will be generated if the target bit of the KRM register is set while a low level is being input to the key interrupt input pin. To ignore this interrupt, set the KRM register after disabling interrupt servicing by using the interrupt mask flag. Afterward, clear the interrupt request flag and enable interrupt servicing after waiting for the key interrupt input low-level width (250 ns or more).
  3. The pins not used in the key interrupt mode can be used as normal ports.

- Remarks**
1. n = 0 to 7
  2. KR0 to KR3: 40-, 44-pin products  
 KR0 to KR5: 48-pin products  
 KR0 to KR7: 52-, 64-, 80-, 100-, 128-pin products

## CHAPTER 18 STANDBY FUNCTION

### 18.1 Standby Function and Configuration

#### 18.1.1 Standby function

The standby function reduces the operating current of the system, and the following three modes are available.

##### (1) HALT mode

HALT instruction execution sets the HALT mode. In the HALT mode, the CPU operation clock is stopped. If the high-speed system clock oscillator, high-speed on-chip oscillator, or subsystem clock oscillator is operating before the HALT mode is set, oscillation of each clock continues. In this mode, the operating current is not decreased as much as in the STOP mode, but the HALT mode is effective for restarting operation immediately upon interrupt request generation and carrying out intermittent operations frequently.

##### (2) STOP mode

STOP instruction execution sets the STOP mode. In the STOP mode, the high-speed system clock oscillator and high-speed on-chip oscillator stop, stopping the whole system, thereby considerably reducing the CPU operating current.

Because this mode can be cleared by an interrupt request, it enables intermittent operations to be carried out. However, because a wait time is required to secure the oscillation stabilization time after the STOP mode is released when the X1 clock is selected, select the HALT mode if it is necessary to start processing immediately upon interrupt request generation.

##### (3) SNOOZE mode

In the case of CSIp or UARTq data reception and an A/D conversion request by the timer trigger signal (the interrupt request signal (INTRTC/INTIT)), the STOP mode is exited, the CSIp or UARTq data is received without operating the CPU, and A/D conversion is performed. This can only be specified when the high-speed on-chip oscillator is selected for the CPU/peripheral hardware clock (f<sub>CLK</sub>).

In either of these two modes, all the contents of registers, flags and data memory just before the standby mode is set are held. The I/O port output latches and output buffer statuses are also held.

**Cautions** 1. The STOP mode can be used only when the CPU is operating on the main system clock. The STOP mode cannot be set while the CPU operates with the subsystem clock. The HALT mode can be used when the CPU is operating on either the main system clock or the subsystem clock.

<R> 2. When shifting to the STOP mode, be sure to stop the peripheral hardware operation operating with main system clock before executing STOP instruction.

<R> 3. When using CSIp, UARTq, or the A/D converter in the SNOOZE mode, set up serial standby control register m (SSCm) and A/D converter mode register 2 (ADM2) before switching to the STOP mode. For details, see 12.3 Registers Controlling Serial Array Unit and 11.3 Registers Used in A/D Converter.

<R> 4. The following sequence is recommended for power consumption reduction of the A/D converter when the standby function is used: First clear bit 7 (ADCS) and bit 0 (ADCE) of A/D converter mode register 0 (ADM0) to 0 to stop the A/D conversion operation, and then execute the STOP instruction.

5. It can be selected by the option byte whether the low-speed on-chip oscillator continues oscillating or stops in the HALT or STOP mode. For details, see CHAPTER 24 OPTION BYTE.

<R> **Remark** 20 to 64-pin products: p = 00; q = 0; m = 0  
80, 100, 128-pin products: p = 00, 20; q = 0, 2; m = 0, 1



### 18.1.2 Registers controlling standby function

The standby function is controlled by the following two registers.

- Oscillation stabilization time counter status register (OSTC)
- Oscillation stabilization time select register (OSTS)

**Remark** For the registers that start, stop, or select the clock, see **CHAPTER 5 CLOCK GENERATOR**.

**(1) Oscillation stabilization time counter status register (OSTC)**

This is the register that indicates the count status of the X1 clock oscillation stabilization time counter.

The X1 clock oscillation stabilization time can be checked in the following case.

- If the X1 clock starts oscillation while the high-speed on-chip oscillator clock or subsystem clock is being used as the CPU clock.
- If the STOP mode is entered and then released while the high-speed on-chip oscillator clock is being used as the CPU clock with the X1 clock oscillating.

The OSTC register can be read by a 1-bit or 8-bit memory manipulation instruction.

When reset is released (reset by RESET input, POR, LVD, WDT, and executing an illegal instruction), the STOP instruction and MSTOP bit (bit 7 of clock operation status control register (CSC)) = 1 clear this register to 00H.

**Figure 18-1. Format of Oscillation Stabilization Time Counter Status Register (OSTC)**

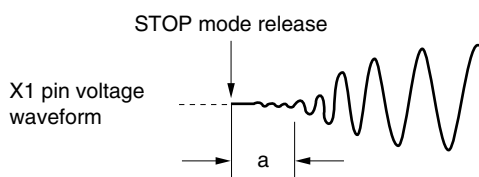
Address: FFFA2H After reset: 00H R

Symbol	7	6	5	4	3	2	1	0
OSTC	MOST 8	MOST 9	MOST 10	MOST 11	MOST 13	MOST 15	MOST 17	MOST 18

MOST 8	MOST 9	MOST 10	MOST 11	MOST 13	MOST 15	MOST 17	MOST 18	Oscillation stabilization time status		
									fx = 10 MHz	fx = 20 MHz
0	0	0	0	0	0	0	0	2 <sup>8</sup> /fx max.	25.6 μs max.	12.8 μs max.
1	0	0	0	0	0	0	0	2 <sup>9</sup> /fx min.	25.6 μs min.	12.8 μs min.
1	1	0	0	0	0	0	0	2 <sup>9</sup> /fx min.	51.2 μs min.	25.6 μs min.
1	1	1	0	0	0	0	0	2 <sup>10</sup> /fx min.	102.4 μs min.	51.2 μs min.
1	1	1	1	0	0	0	0	2 <sup>11</sup> /fx min.	204.8 μs min.	102.4 μs min.
1	1	1	1	1	0	0	0	2 <sup>13</sup> /fx min.	819.2 μs min.	409.6 μs min.
1	1	1	1	1	1	0	0	2 <sup>15</sup> /fx min.	3.27 ms min.	1.64 ms min.
1	1	1	1	1	1	1	0	2 <sup>17</sup> /fx min.	13.11 ms min.	6.55 ms min.
1	1	1	1	1	1	1	1	2 <sup>18</sup> /fx min.	26.21 ms min.	13.11 ms min.

- Cautions**
1. After the above time has elapsed, the bits are set to 1 in order from the MOST8 bit and remain 1.
  2. The oscillation stabilization time counter counts up to the oscillation stabilization time set by the oscillation stabilization time select register (OSTS). If the STOP mode is entered and then released while the high-speed on-chip oscillator clock is being used as the CPU clock, set the oscillation stabilization time as follows.
    - Desired OSTC register oscillation stabilization time ≤ Oscillation stabilization time set by OSTS register

Note, therefore, that only the status up to the oscillation stabilization time set by the OSTS register is set to the OSTC register after STOP mode is released.
  3. The X1 clock oscillation stabilization wait time does not include the time until clock oscillation starts (“a” below).



**Remark** fx: X1 clock oscillation frequency

**(2) Oscillation stabilization time select register (OSTS)**

This register is used to select the X1 clock oscillation stabilization wait time when the STOP mode is released. When the X1 clock is selected as the CPU clock, the operation waits for the time set using the OSTS register after the STOP mode is released. When the high-speed on-chip oscillator clock is selected as the CPU clock, confirm with the oscillation stabilization time counter status register (OSTC) that the desired oscillation stabilization time has elapsed after the STOP mode is released. The oscillation stabilization time can be checked up to the time set using the OSTC register. The OSTS register can be set by an 8-bit memory manipulation instruction. Reset signal generation sets this register to 07H.

**Figure 18-2. Format of Oscillation Stabilization Time Select Register (OSTS)**

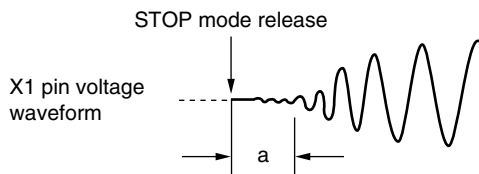
Address: FFFA3H After reset: 07H R/W

Symbol	7	6	5	4	3	2	1	0
OSTS	0	0	0	0	0	OSTS2	OSTS1	OSTS0

OSTS2	OSTS1	OSTS0	Oscillation stabilization time selection		
				$f_x = 10 \text{ MHz}$	$f_x = 20 \text{ MHz}$
0	0	0	$2^8/f_x$	25.6 $\mu\text{s}$	12.8 $\mu\text{s}$
0	0	1	$2^9/f_x$	51.2 $\mu\text{s}$	25.6 $\mu\text{s}$
0	1	0	$2^{10}/f_x$	102.4 $\mu\text{s}$	51.2 $\mu\text{s}$
0	1	1	$2^{11}/f_x$	204.8 $\mu\text{s}$	102.4 $\mu\text{s}$
1	0	0	$2^{13}/f_x$	819.2 $\mu\text{s}$	409.6 $\mu\text{s}$
1	0	1	$2^{15}/f_x$	3.27 ms	1.64 ms
1	1	0	$2^{17}/f_x$	13.11 ms	6.55 ms
1	1	1	$2^{18}/f_x$	26.21 ms	13.11 ms

- Cautions**
- To set the STOP mode when the X1 clock is used as the CPU clock, set the OSTS register before executing the STOP instruction.
  - Before changing the setting of the OSTS register, confirm that the count operation of the OSTC register is completed.
  - Do not change the value of the OSTS register during the X1 clock oscillation stabilization time.
  - The oscillation stabilization time counter counts up to the oscillation stabilization time set by the OSTS register. If the STOP mode is entered and then released while the high-speed on-chip oscillator clock is being used as the CPU clock, set the oscillation stabilization time as follows.
    - Desired OSTC register oscillation stabilization time  $\leq$  Oscillation stabilization time set by OSTS register

Note, therefore, that only the status up to the oscillation stabilization time set by the OSTS register is set to the OSTC register after STOP mode is released.
  - The X1 clock oscillation stabilization wait time does not include the time until clock oscillation starts (“a” below).



**Remark**  $f_x$ : X1 clock oscillation frequency

## 18.2 Standby Function Operation

### 18.2.1 HALT mode

#### (1) HALT mode

The HALT mode is set by executing the HALT instruction. HALT mode can be set regardless of whether the CPU clock before the setting was the high-speed system clock, high-speed on-chip oscillator clock, or subsystem clock.

The operating statuses in the HALT mode are shown below.

**Table 18-1. Operating Statuses in HALT Mode (1/2)**

HALT Mode Setting		When HALT Instruction Is Executed While CPU Is Operating on Main System Clock					
		When CPU Is Operating on High-speed On-chip Oscillator Clock (f <sub>IH</sub> )	When CPU Is Operating on X1 Clock (fx)	When CPU Is Operating on External Main System Clock (f <sub>EX</sub> )			
System clock		Clock supply to the CPU is stopped					
Main system clock	f <sub>IH</sub>	Operation continues (cannot be stopped)	Operation disabled				
	f <sub>x</sub>	Operation disabled	Operation continues (cannot be stopped)	Cannot operate			
	f <sub>EX</sub>		Cannot operate	Operation continues (cannot be stopped)			
Subsystem clock	f <sub>XT</sub>	Status before HALT mode was set is retained					
	f <sub>EXS</sub>						
f <sub>IL</sub>		Set by bits 0 (WDSTBYON) and 4 (WDTON) of option byte (000C0H), and WUTMMCK0 bit of operation speed mode control register (OSMC) <ul style="list-style-type: none"> <li>• WUTMMCK0 = 1: Oscillates</li> <li>• WUTMMCK0 = 0 and WDTON = 0: Stops</li> <li>• WUTMMCK0 = 0, WDTON = 1, and WDSTBYON = 1: Oscillates</li> <li>• WUTMMCK0 = 0, WDTON = 1, and WDSTBYON = 0: Stops</li> </ul>					
CPU		Operation stopped					
Code flash memory		Operation stopped					
Data flash memory							
RAM							
Port (latch)							
Timer array unit		Operable					
Real-time clock (RTC)							
Interval timer							
Watchdog timer							
Clock output/buzzer output		Operable					
A/D converter							
Serial array unit (SAU)							
Serial interface (IICA)							
Multiplier and divider/multiply-accumulator							
DMA controller							
Power-on-reset function							
Voltage detection function							
External interrupt							
Key interrupt function							
CRC operation function	High-speed CRC						
	General-purpose CRC						
Illegal-memory access detection function							

**Remark** Operation stopped: Operation is automatically stopped before switching to the HALT mode.  
 Operation disabled: Operation is stopped before switching to the HALT mode.  
 f<sub>IH</sub>: High-speed on-chip oscillator clock  
 f<sub>IL</sub>: Low-speed on-chip oscillator clock  
 f<sub>x</sub>: X1 clock  
 f<sub>EX</sub>: External main system clock  
 f<sub>XT</sub>: XT1 clock  
 f<sub>EXS</sub>: External subsystem clock

**Table 18-1. Operating Statuses in HALT Mode (2/2)**

HALT Mode Setting Item		When HALT Instruction Is Executed While CPU Is Operating on Subsystem Clock	
		When CPU Is Operating on XT1 Clock (f <sub>XT</sub> )	When CPU Is Operating on External Subsystem Clock (f <sub>EXS</sub> )
System clock		Clock supply to the CPU is stopped	
Main system clock	f <sub>IH</sub>	Operation disabled	
	f <sub>X</sub>		
	f <sub>EX</sub>		
Subsystem clock	f <sub>XT</sub>	Operation continues (cannot be stopped)	Cannot operate
	f <sub>EXS</sub>	Cannot operate	Operation continues (cannot be stopped)
f <sub>IL</sub>		Set by bits 0 (WDSTBYON) and 4 (WDTON) of option byte (000C0H), and WUTMMCK0 bit of operation speed mode control register (OSMC) <ul style="list-style-type: none"> <li>• WUTMMCK0 = 1: Oscillates</li> <li>• WUTMMCK0 = 0 and WDTON = 0: Stops</li> <li>• WUTMMCK0 = 0, WDTON = 1, and WDSTBYON = 1: Oscillates</li> <li>• WUTMMCK0 = 0, WDTON = 1, and WDSTBYON = 0: Stops</li> </ul>	
CPU		Operation stopped	
Code flash memory			
Data flash memory			
RAM			
Port (latch)			
Timer array unit		Operable (Operation is disabled while in the low consumption RTC mode (when the RTCLPC bit of the OSMC register is 1))	
Real-time clock (RTC)		Operable	
Interval timer			
Watchdog timer		See CHAPTER 10 WATCHDOG TIMER	
Clock output/buzzer output		Operable (Operation is disabled while in the low consumption RTC mode (when the RTCLPC bit of the OSMC register is 1))	
A/D converter		Operation disabled	
Serial array unit (SAU)		Operable (Operation is disabled while in the low consumption RTC mode (when the RTCLPC bit of the OSMC register is 1))	
Serial interface (IICA)		Operation disabled	
Multiplier and divider/multiply-accumulator		Operable (Operation is disabled while in the low consumption RTC mode (when the RTCLPC bit of the OSMC register is 1))	
DMA controller			
Power-on-reset function		Operable	
Voltage detection function			
External interrupt			
Key interrupt function			
CRC operation function	High-speed CRC	Operation disabled	
	General-purpose CRC	Operable	
Illegal-memory access detection function		Operation stopped	

**Remark** Operation stopped: Operation is automatically stopped before switching to the HALT mode.

Operation disabled: Operation is stopped before switching to the HALT mode.

f<sub>IH</sub>: High-speed on-chip oscillator clock

f<sub>IL</sub>: Low-speed on-chip oscillator clock

f<sub>X</sub>: X1 clock

f<sub>EX</sub>: External main system clock

f<sub>XT</sub>: XT1 clock

f<sub>EXS</sub>: External subsystem clock

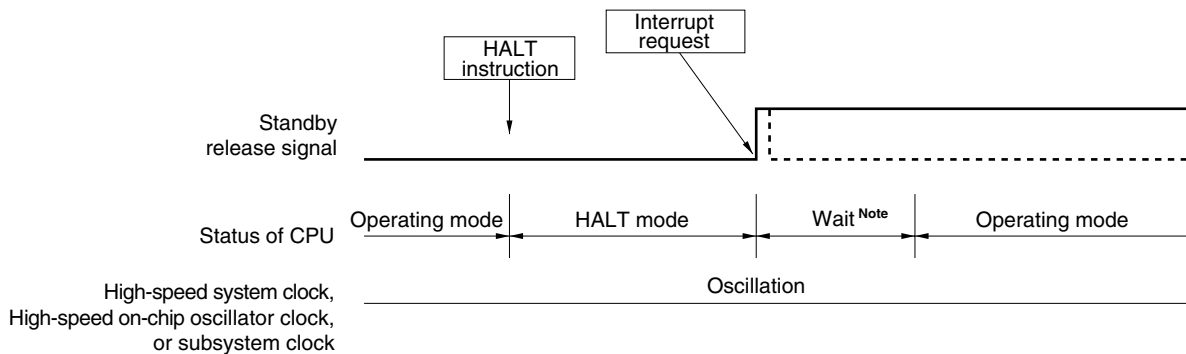
**(2) HALT mode release**

The HALT mode can be released by the following two sources.

**(a) Release by unmasked interrupt request**

When an unmasked interrupt request is generated, the HALT mode is released. If interrupt acknowledgment is enabled, vectored interrupt servicing is carried out. If interrupt acknowledgment is disabled, the next address instruction is executed.

**Figure 18-3. HALT Mode Release by Interrupt Request Generation**



<R> **Note** Wait time for HALT mode release

- When vectored interrupt servicing is carried out
  - Main system clock: 13 to 15 clock
  - Subsystem clock (RTCLPC = 0): 8 to 10 clock
  - Subsystem clock (RTCLPC = 1): 9 to 11 clock
- When vectored interrupt servicing is not carried out
  - Main system clock: 8 to 9 clock
  - Subsystem clock (RTCLPC = 0): 3 to 4 clock
  - Subsystem clock (RTCLPC = 1): 4 to 5 clock

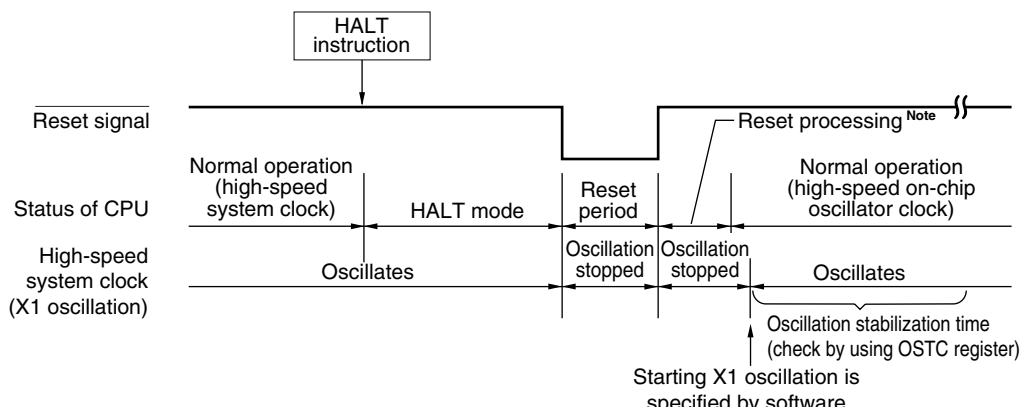
**Remark** The broken lines indicate the case when the interrupt request which has released the standby mode is acknowledged.

**(b) Release by reset signal generation**

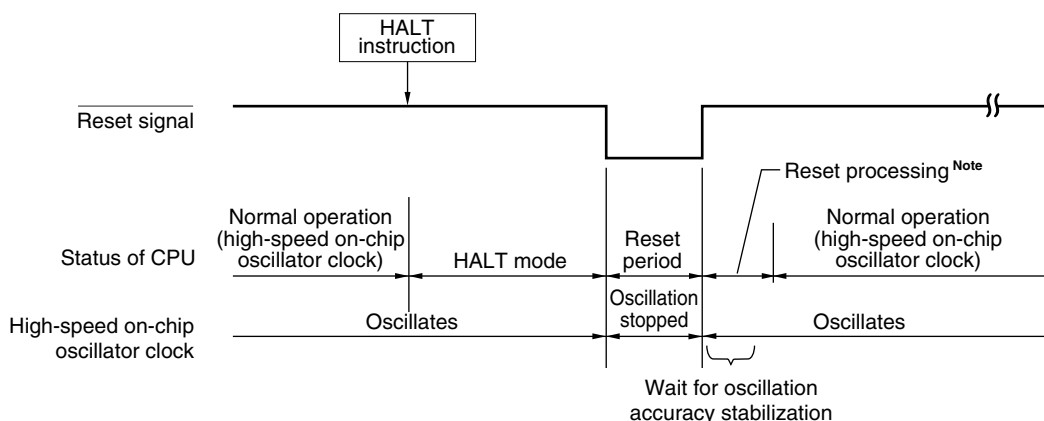
When the reset signal is generated, HALT mode is released, and then, as in the case with a normal reset operation, the program is executed after branching to the reset vector address.

**Figure 18-4. HALT Mode Release by Reset**

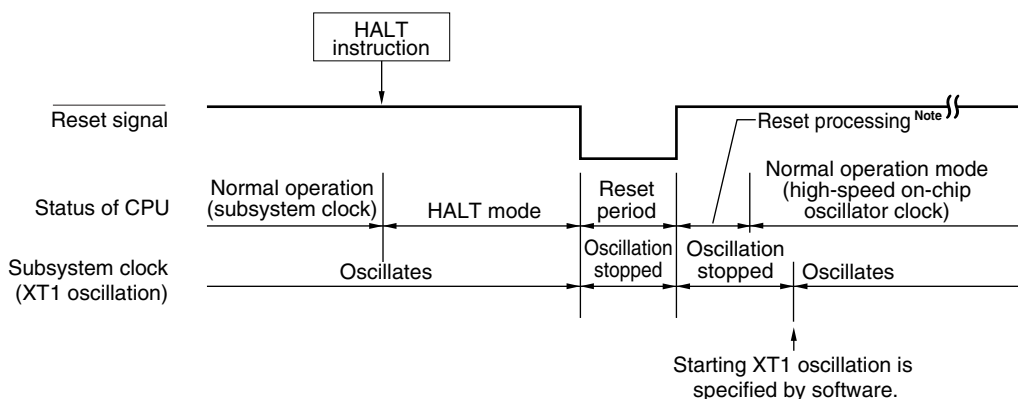
**(1) When high-speed system clock is used as CPU clock**



**When high-speed on-chip oscillator clock is used as CPU clock**



**(3) When subsystem clock is used as CPU clock**



<R> **Note** Reset processing time: 387 to 720  $\mu$ s (When LVD is used)  
 155 to 407  $\mu$ s (When LVD off)



## 18.2.2 STOP mode

### (1) STOP mode setting and operating statuses

The STOP mode is set by executing the STOP instruction, and it can be set only when the CPU clock before the setting was the high-speed on-chip oscillator clock, X1 clock, or external main system clock.

- Cautions**
1. **Because the interrupt request signal is used to clear the standby mode, if there is an interrupt source with the interrupt request flag set and the interrupt mask flag reset, the standby mode is immediately cleared if set. Thus, the STOP mode is reset to the HALT mode immediately after execution of the STOP instruction and the system returns to the operating mode as soon as the wait time set using the oscillation stabilization time select register (OSTS) has elapsed.**
  2. **When using CSIp, UARTq, or the A/D converter in the SNOOZE mode, set up serial standby control register m (SSCm) and A/D converter mode register 2 (ADM2) before switching to the STOP mode. For details, see 12.3 Registers Controlling Serial Array Unit and 11.3 Registers Used in A/D Converter.**

<R> **Remark** 20 to 64-pin products: p = 00; q = 0; m = 0  
80, 100, 128-pin products: p = 00, 20; q = 0, 2; m = 0, 1

The operating statuses in the STOP mode are shown below.

**Table 18-2. Operating Statuses in STOP Mode**

STOP Mode Setting Item		When STOP Instruction Is Executed While CPU Is Operating on Main System Clock		
		When CPU Is Operating on High-speed on-chip oscillator clock ( $f_{IH}$ )	When CPU Is Operating on X1 Clock ( $f_x$ )	When CPU Is Operating on External Main System Clock ( $f_{EX}$ )
System clock		Clock supply to the CPU is stopped		
Main system clock	$f_{IH}$	Stopped		
	$f_x$			
	$f_{EX}$			
Subsystem clock	$f_{XT}$	Status before STOP mode was set is retained		
	$f_{EXS}$			
$f_{IL}$	Set by bits 0 (WDSTBYON) and 4 (WDTON) of option byte (000C0H), and WUTMMCK0 bit of operation speed mode control register (OSMC)			
		<ul style="list-style-type: none"> <li>• WUTMMCK0 = 1: Oscillates</li> <li>• WUTMMCK0 = 0 and WDTON = 0: Stops</li> <li>• WUTMMCK0 = 0, WDTON = 1, and WDSTBYON = 1: Oscillates</li> <li>• WUTMMCK0 = 0, WDTON = 1, and WDSTBYON = 0: Stops</li> </ul>		
CPU		Operation stopped		
Code flash memory				
Data flash memory		Operation stopped (The STOP instruction is not executed during data flash programming)		
RAM		Operation stopped		
Port (latch)		Status before STOP mode was set is retained		
Timer array unit		Operation disabled		
Real-time clock (RTC)		Operable		
Interval timer				
Watchdog timer		See CHAPTER 10 WATCHDOG TIMER		
Clock output/buzzer output		Operable only when subsystem clock is selected as the count clock		
A/D converter		Wakeup operation is enabled (switching to the SNOOZE mode)		
Serial array unit (SAU)		Wakeup operation is enabled only for CSIp and UARTq (switching to the SNOOZE mode) Operation is disabled for anything other than CSIp and UARTq		
Serial interface (IICA)		Wakeup by address match operable		
Multiplier and divider/multiply-accumulator		Operation disabled		
DMA controller				
Power-on-reset function		Operable		
Voltage detection function				
External interrupt				
Key interrupt function				
CRC operation function	High-speed CRC	Operation stopped		
	General-purpose CRC			
Illegal-memory access detection function				

**Remarks 1.** Operation stopped: Operation is automatically stopped before switching to the STOP mode.

Operation disabled: Operation is stopped before switching to the STOP mode.

$f_{IH}$ : High-speed on-chip oscillator clock       $f_{IL}$ : Low-speed on-chip oscillator clock

$f_x$ : X1 clock       $f_{EX}$ : External main system clock

$f_{XT}$ : XT1 clock       $f_{EXS}$ : External subsystem clock

<R>      **2.** 20 to 64-pin products:       $p = 00; q = 0$   
 80, 100, 128-pin products:       $p = 00, 20; q = 0, 2$

**Cautions** 1. To use the peripheral hardware that stops operation in the STOP mode, and the peripheral hardware for which the clock that stops oscillating in the STOP mode after the STOP mode is released, restart the peripheral hardware.

- <R>
2. To stop the low-speed on-chip oscillator clock in the STOP mode, must previously be set an option byte to stop the watchdog timer operation in the HALT/STOP mode (bit 0 (WDSTBYON) of 000C0H = 0).
  3. To shorten oscillation stabilization time after the STOP mode is released when the CPU operates with the high-speed system clock (X1 oscillation), temporarily switch the CPU clock to the high-speed on-chip oscillator clock before the execution of the STOP instruction. Before changing the CPU clock from the high-speed on-chip oscillator clock to the high-speed system clock (X1 oscillation) after the STOP mode is released, check the oscillation stabilization time with the oscillation stabilization time counter status register (OSTC).

**(2) STOP mode release**

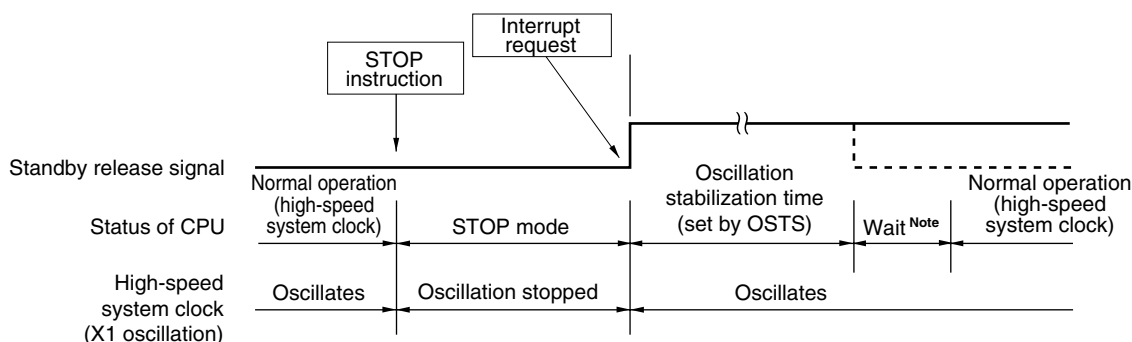
The STOP mode can be released by the following two sources.

**(a) Release by unmasked interrupt request**

When an unmasked interrupt request is generated, the STOP mode is released. After the oscillation stabilization time has elapsed, if interrupt acknowledgment is enabled, vectored interrupt servicing is carried out. If interrupt acknowledgment is disabled, the next address instruction is executed.

**Figure 18-5. STOP Mode Release by Interrupt Request Generation (1/2)**

**(1) When high-speed system clock (X1 oscillation) is used as CPU clock**

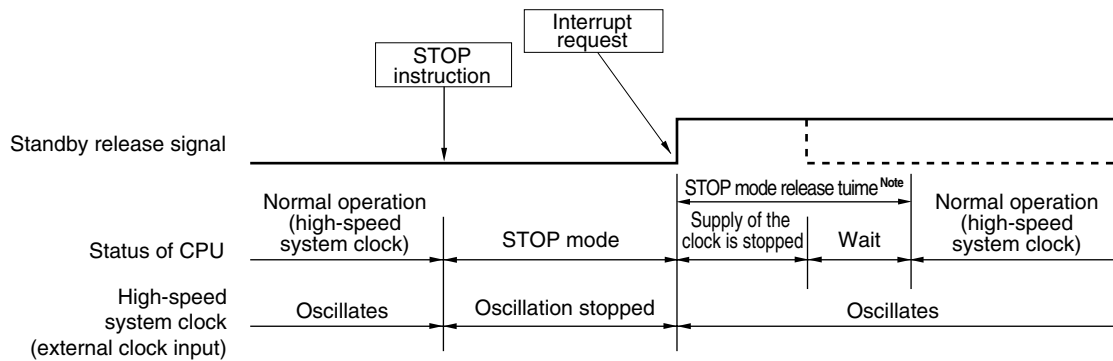


- <R>
- Note** Wait time for STOP mode release
- High-speed system clock (X1 oscillation): 3-clock

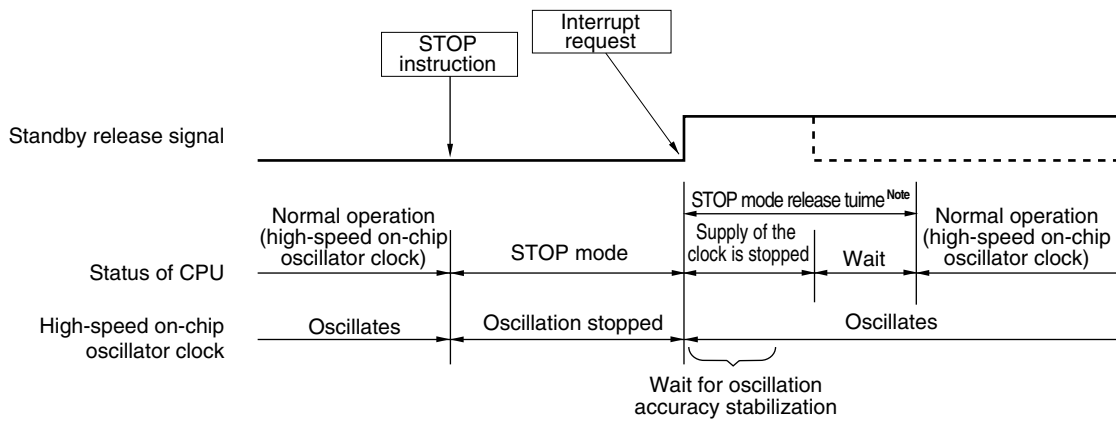
**Remark** The broken lines indicate the case when the interrupt request that has released the standby mode is acknowledged.

Figure 18-5. STOP Mode Release by Interrupt Request Generation (2/2)

(2) When high-speed system clock (external clock input) is used as CPU clock



(3) When high-speed on-chip oscillator clock is used as CPU clock



<R>

**Note** STOP mode release time:

- High-speed system clock (external clock input): 19.1 to 31.98  $\mu$ s
- High-speed on-chip oscillator clock: 19.1 to 31.98  $\mu$ s

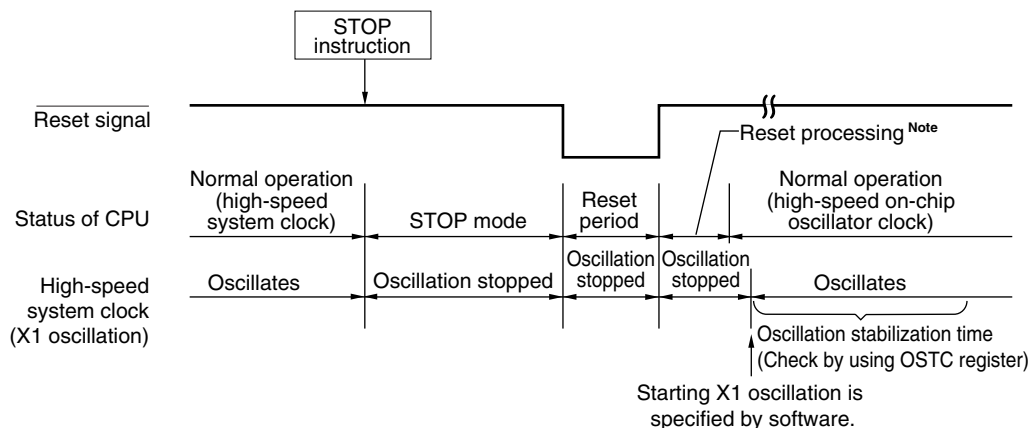
**Remark** The broken lines indicate the case when the interrupt request that has released the standby mode is acknowledged.

**(b) Release by reset signal generation**

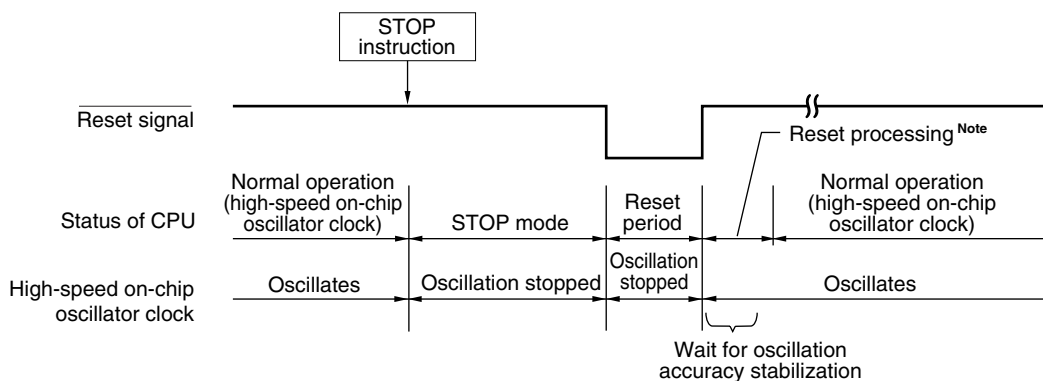
When the reset signal is generated, STOP mode is released, and then, as in the case with a normal reset operation, the program is executed after branching to the reset vector address.

**Figure 18-6. STOP Mode Release by Reset**

**(1) When high-speed system clock is used as CPU clock**



**(2) When high-speed on-chip oscillator clock is used as CPU clock**



<R> **Note** Reset processing time: 387 to 720  $\mu$ s (When LVD is used)  
155 to 407  $\mu$ s (When LVD off)

**Remark** fx: X1 clock oscillation frequency

### 18.2.3 SNOOZE mode

#### (1) SNOOZE mode setting and operating statuses

The SNOOZE mode can only be specified for CSIp, UARTq, or the A/D converter. Note that this mode can only be specified if the CPU clock is the high-speed on-chip oscillator clock.

When using CSIp or UARTq in the SNOOZE mode, set up serial standby control register m (SSCm) before switching to the STOP mode. For details, see **12.3 Registers Controlling Serial Array Unit**.

When using the A/D converter in the SNOOZE mode, set up A/D converter mode register 2 (ADM2) before switching to the STOP mode. For details, see **11.3 Registers Used in A/D Converter**.

<R> **Remark** 20 to 64-pin products: p = 00; q = 0; m = 0  
80, 100, 128-pin products: p = 00, 20; q = 0, 2; m = 0, 1

The operating statuses in the SNOOZE mode are shown below.

**Table 18-3. Operating Statuses in SNOOZE Mode**

STOP Mode Setting Item		When Inputting CSIp/UARTq Data Reception Signal or A/D Converter Timer Trigger Signal While in STOP Mode	
		When CPU Is Operating on High-speed on-chip oscillator clock ( $f_{IH}$ )	
System clock		Clock supply to the CPU is stopped	
Main system clock	$f_{IH}$	Operation started	
	$f_X$	Stopped	
	$f_{EX}$		
Subsystem clock	$f_{XT}$	Use of the status while in the STOP mode continues	
	$f_{EXS}$		
$f_{IL}$	Set by bits 0 (WDSTBYON) and 4 (WDTON) of option byte (000C0H), and WUTMMCK0 bit of operation speed mode control register (OSMC)		
CPU		Operation stopped	
Code flash memory			
Data flash memory			
RAM			
Port (latch)		Use of the status while in the STOP mode continues	
Timer array unit		Operation disabled	
Real-time clock (RTC)		Operable	
Interval timer			
Watchdog timer		See CHAPTER 10 WATCHDOG TIMER	
Clock output/buzzer output		Operable only when subsystem clock is selected as the count clock	
A/D converter		Operable	
Serial array unit (SAU)		Operable only CSIp and UARTq only. Operation disabled other than CSIp and UARTq.	
Serial interface (IICA)		Operation disabled	
Multiplier and divider/multiply-accumulator			
DMA controller			
Power-on-reset function		Operable	
Voltage detection function			
External interrupt			
Key interrupt function			
CRC operation function		Operation disabled	
Illegal-memory access detection function			

**Remarks 1.** Operation stopped: Operation is automatically stopped before switching to the SNOOZE mode.

Operation disabled: Operation is stopped before switching to the SNOOZE mode.

$f_{IH}$ : High-speed on-chip oscillator clock       $f_{IL}$ : Low-speed on-chip oscillator clock

$f_X$ : X1 clock       $f_{EX}$ : External main system clock

$f_{XT}$ : XT1 clock       $f_{EXS}$ : External subsystem clock

- <R>      **2.** 20 to 64-pin products:       $p = 00; q = 0$   
 80, 100, 128-pin products:       $p = 00, 20; q = 0, 2$

## CHAPTER 19 RESET FUNCTION

The following seven operations are available to generate a reset signal.

- (1) External reset input via  $\overline{\text{RESET}}$  pin
- (2) Internal reset by watchdog timer program loop detection
- (3) Internal reset by comparison of supply voltage and detection voltage of power-on-reset (POR) circuit
- (4) Internal reset by comparison of supply voltage of the voltage detector (LVD) and detection voltage
- (5) Internal reset by execution of illegal instruction<sup>Note</sup>
- (6) Internal reset by RAM parity error
- (7) Internal reset by illegal-memory access

External and internal resets start program execution from the address at 0000H and 0001H when the reset signal is generated.

A reset is effected when a low level is input to the  $\overline{\text{RESET}}$  pin, the watchdog timer overflows, or by POR and LVD circuit voltage detection, execution of illegal instruction<sup>Note</sup>, RAM parity error or illegal-memory access, and each item of hardware is set to the status shown in Tables 19-1.

<R> When a low level is input to the  $\overline{\text{RESET}}$  pin, the device is reset. It is released from the reset status when a high level is input to the  $\overline{\text{RESET}}$  pin and program execution is started with the high-speed on-chip oscillator clock after reset processing. A reset by the watchdog timer is automatically released, and program execution starts using the high-speed on-chip oscillator clock (see **Figures 19-2 to 19-4**) after reset processing. Reset by POR and LVD circuit supply voltage detection is automatically released when  $V_{DD} \geq V_{POR}$  or  $V_{DD} \geq V_{LVI}$  after the reset, and program execution starts using the high-speed on-chip oscillator clock (see **CHAPTER 20 POWER-ON-RESET CIRCUIT** and **CHAPTER 21 VOLTAGE DETECTOR**) after reset processing.

**Note** The illegal instruction is generated when instruction code FFH is executed.

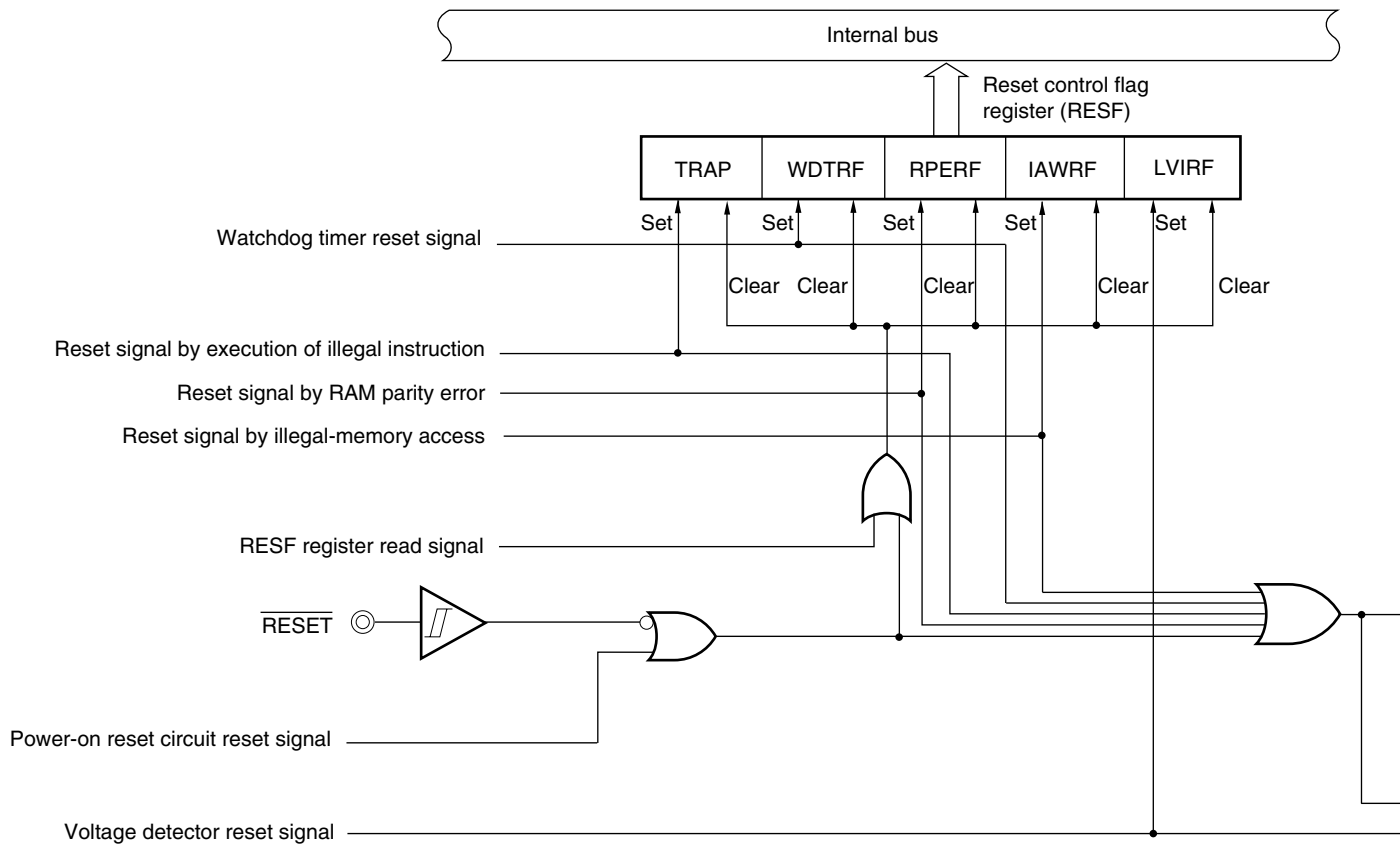
Reset by the illegal instruction execution not issued by emulation with the in-circuit emulator or on-chip debug emulator.

- Cautions**
1. For an external reset, input a low level for 10  $\mu\text{s}$  or more to the  $\overline{\text{RESET}}$  pin.  
(To perform an external reset upon power application, a low level of at least 10  $\mu\text{s}$  must be continued during the period in which the supply voltage is within the operating range ( $V_{DD} \geq 1.6$  V).)
  2. During reset input, the X1 clock, XT1 clock, high-speed on-chip oscillator clock, and low-speed on-chip oscillator clock stop oscillating. External main system clock input and external subsystem clock input become invalid.
  3. When reset is effected, port pin P130 is set to low-level output and other port pins become high-impedance, because each SFR and 2nd SFR are initialized.

**Remark**  $V_{POR}$ : POR power supply rise detection voltage



**Figure 19-1. Block Diagram of Reset Function**

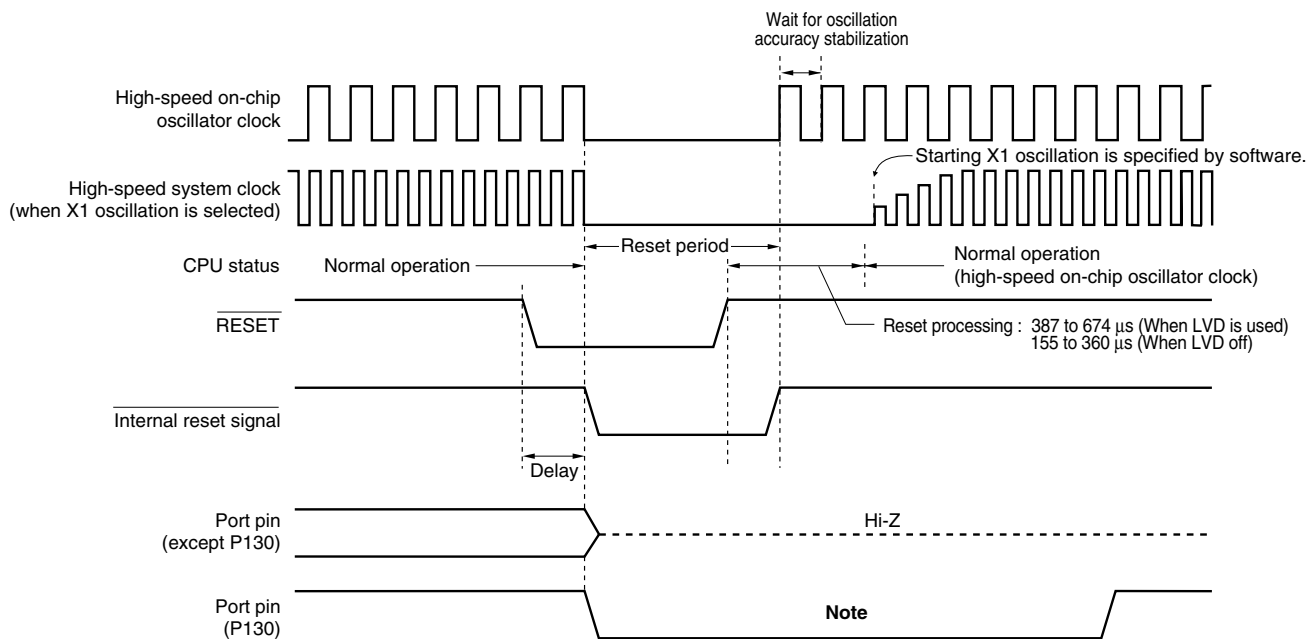


**Caution** An LVD circuit internal reset does not reset the LVD circuit.

- Remarks**
1. LVIM: Voltage detection register
  2. LVIS: Voltage detection level register

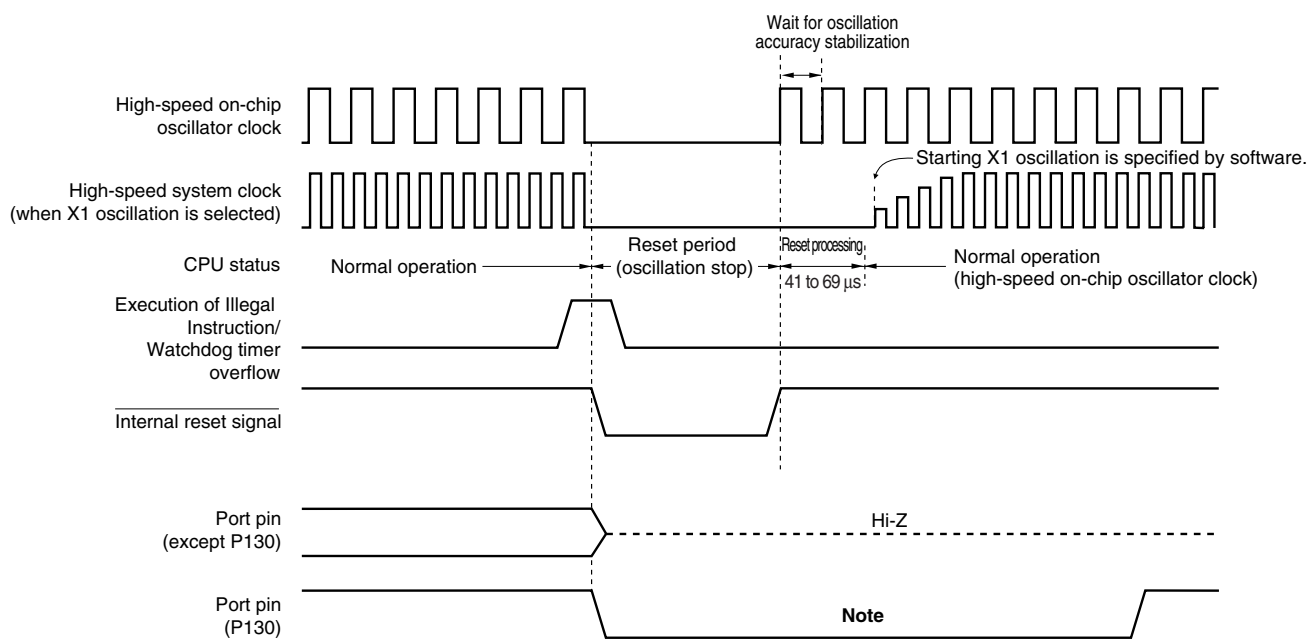
<R>

**Figure 19-2. Timing of Reset by RESET Input**



<R>

**Figure 19-3. Timing of Reset Due to Execution of Illegal Instruction or Watchdog Timer Overflow**

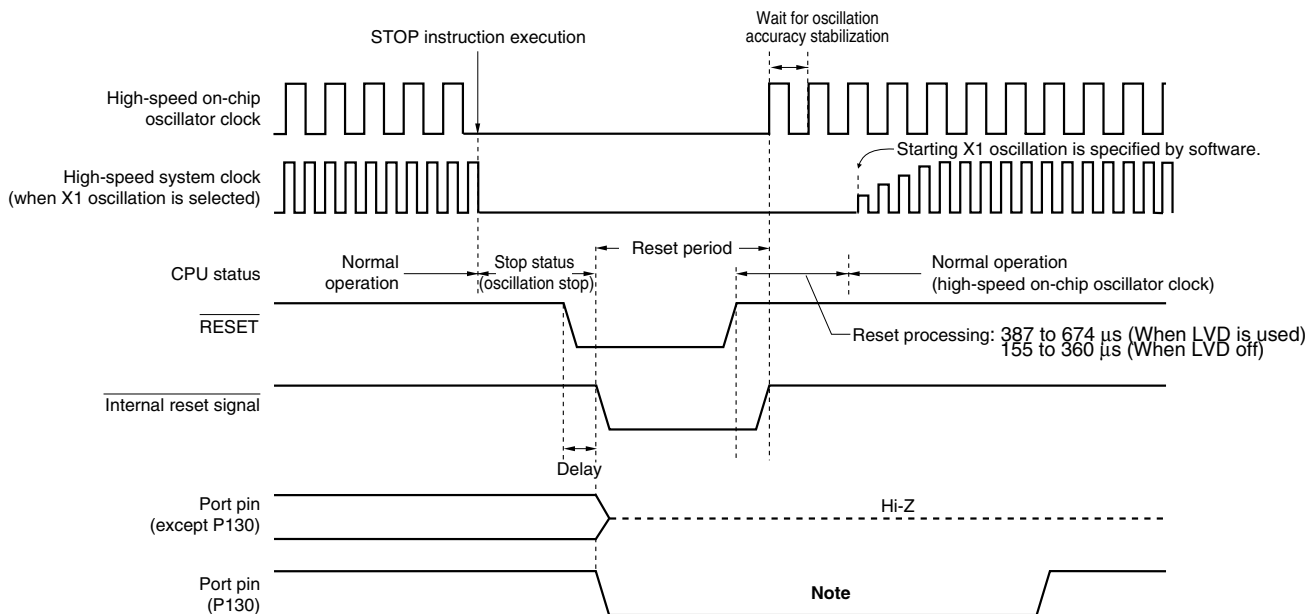


**Note** When P130 is set to high-level output before reset is effected, the output signal of P130 can be dummy-output as a reset signal to an external device, because P130 outputs a low level when reset is effected. To release a reset signal to an external device, set P130 to high-level output by software.

**Caution** A watchdog timer internal reset resets the watchdog timer.

<R>

**Figure 19-4. Timing of Reset in STOP Mode by  $\overline{\text{RESET}}$  Input**



**Note** When P130 is set to high-level output before reset is effected, the output signal of P130 can be dummy-output as a reset signal to an external device, because P130 outputs a low level when reset is effected. To release a reset signal to an external device, set P130 to high-level output by software.

**Remark** For the reset timing of the power-on-reset circuit and voltage detector, see **CHAPTER 20 POWER-ON-RESET CIRCUIT** and **CHAPTER 21 VOLTAGE DETECTOR**.

Table 19-1. Operation Statuses During Reset Period

Item	During Reset Period			
System clock	Clock supply to the CPU is stopped.			
Main system clock	$f_{IH}$	Operation stopped		
	$f_x$	Operation stopped (the X1 and X2 pins are input port mode)		
	$f_{EX}$	Clock input invalid (the pin is input port mode)		
Subsystem clock	$f_{XT}$	Operation stopped (the XT1 and XT2 pins are input port mode)		
	$f_{EXS}$	Clock input invalid (the pin is input port mode)		
$f_{IL}$	Operation stopped			
CPU				
Code flash memory	Operation stopped			
Data flash memory	Operation stopped			
RAM	Operation stopped			
Port (latch)	Set P130 to low-level output. The port pins except for P130 become high impedance.			
Timer array unit	Operation stopped			
Real-time clock (RTC)				
Interval timer				
Watchdog timer				
Clock output/buzzer output				
A/D converter				
Serial array unit (SAU)				
Serial interface (IICA)				
Multiplier & divider, multiply-accumulator				
DMA controller				
Power-on-reset function			Detection operation possible	
Voltage detection function			Operation stopped	
External interrupt			Operation stopped	
Key interrupt function				
CRC operation function	High-speed CRC			
	General-purpose CRC			
RAM parity error detection function				
RAM guard function				
SFR guard function				
Illegal-memory access detection function				

**Remark**

- $f_{IH}$ : High-speed on-chip oscillator clock
- $f_x$ : X1 oscillation clock
- $f_{EX}$ : External main system clock
- $f_{XT}$ : XT1 oscillation clock
- $f_{EXS}$ : External subsystem clock
- $f_{IL}$ : Low-speed on-chip oscillator clock

Table 19-2. Hardware Statuses After Reset Acknowledgment (1/4)

Hardware		After Reset Acknowledgment <sup>Note 1</sup>
Program counter (PC)		The contents of the reset vector table (0000H, 0001H) are set.
Stack pointer (SP)		Undefined
Program status word (PSW)		06H
RAM	Data memory	Undefined
	General-purpose registers	Undefined
Processor mode control register (PMC)		00H
Port registers (P0 to P15) (output latches)		00H
Port mode registers (PM0 to PM12, PM14, PM15)		FFH
Port mode control registers (PMC0 to PMC3, PMC10, PMC11, PMC12, PMC14)		FFH
Port input mode registers (PIM0, PIM1, PIM4, PIM5, PIM8, PIM14)		00H
Port output mode registers (POM0, POM1, POM4, POM5, POM7 to POM9, POM14)		00H
Pull-up resistor option registers (PU0, PU1, PU3 to PU12, PU14)		00H (PU4 is 01H)
Peripheral I/O redirection register (PIOR)		00H
Clock operation mode control register (CMC)		00H
Clock operation status control register (CSC)		C0H
<R>	System clock control register (CKC)	00H
Oscillation stabilization time counter status register (OSTC)		00H
Oscillation stabilization time select register (OSTS)		07H
Noise filter enable registers 0, 1, 2 (NFEN0, NFEN1, NFEN2)		00H
Peripheral enable register 0 (PER0)		00H
High-speed on-chip oscillator frequency select register (HOCODIV)		Undefined
High-speed on-chip oscillator trimming register (HIOTRM)		<b>Note 2</b>
Operation speed mode control register (OSMC)		00H
Timer array unit	Timer data registers 00 to 07, 10 to 17 (TDR00 to TDR07, TDR10 to TDR17)	0000H
	Timer mode registers 00 to 07, 10 to 17 (TMR00 to TMR07, TMR10 to TMR17)	0000H
	Timer status registers 00 to 07, 10 to 17 (TSR00 to TSR07, TSR10 to TSR17)	0000H
	Timer input select register 0, 1 (TIS0, TIS1)	00H
	Timer counter registers 00 to 07, 10 to 17 (TCR00 to TCR07, TCR10 to TCR17)	FFFFH
	Timer channel enable status register 0, 1 (TE0, TE1)	0000H
	Timer channel start register 0, 1 (TS0, TS1)	0000H
	Timer channel stop register 0, 1 (TT0, TT1)	0000H
	Timer clock select register 0, 1 (TPS0, TPS1)	0000H
	Timer output register 0, 1 (TO0, TO1)	0000H
	Timer output enable register 0, 1 (TOE0, TOE1)	0000H
	Timer output level register 0, 1 (TOL0, TOL1)	0000H
	Timer output mode registers 0, 1 (TOM0, TOM1)	0000H

**Notes 1.** During reset signal generation or oscillation stabilization time wait, only the PC contents among the hardware statuses become undefined. All other hardware statuses remain unchanged after reset.

<R> **2.** The reset value differs for each chip.

**Remark** The special function register (SFR) mounted depend on the product. See 3.1.4 **Special function registers (SFRs)** and 3.1.5 **Extended special function registers (2nd SFRs: 2nd Special Function Registers)**.

Table 19-2. Hardware Statuses After Reset Acknowledgment (2/4)

Hardware		Status After Reset Acknowledgment <sup>Note 1</sup>
Real-time clock	Second count register (SEC)	00H
	Minute count register (MIN)	00H
	Hour count register (HOUR)	12H
	Week count register (WEEK)	00H
	Day count register (DAY)	01H
	Month count register (MONTH)	01H
	Year count register (YEAR)	00H
	Watch error correction register (SUBCUD)	00H
	Alarm minute register (ALARMWMM)	00H
	Alarm hour register (ALARMWH)	12H
	Alarm week register ALARMWW)	00H
	Control register 0 (RTCC0)	00H
	Control register 1 (RTCC1)	00H
Interval timer	Control register (ITMC)	0FFFH
Clock output/buzzer output controller	Clock output select registers 0, 1 (CKS0, CKS1)	00H
Watchdog timer	Enable register (WDTE)	1AH/9AH <sup>Note 2</sup>
A/D converter	10-bit A/D conversion result register (ADCR)	0000H
	8-bit A/D conversion result register (ADCRH)	00H
	Mode registers 0 to 2 (ADM0 to ADM2)	00H
	Conversion result comparison upper limit setting register (ADUL)	FFH
	Conversion result comparison lower limit setting register (ADLL)	00H
	A/D test register (ADTES)	00H
	Analog input channel specification register (ADS)	00H
	A/D port configuration register (ADPC)	00H
Serial array unit (SAU)	Serial data registers 00 to 03, 10 to 13 (SDR00 to SDR03, SDR10 to SDR13)	0000H
	Serial status registers 00 to 03, 10 to 13 (SSR00 to SSR03, SSR10, SSR13)	0000H
	Serial flag clear trigger registers 00 to 03, 10 to 13 (SIR00 to SIR03, SIR10, SIR13)	0000H
	Serial mode registers 00 to 03, 10 to 13 (SMR00 to SMR03, SMR10, SMR13)	0020H
	Serial communication operation setting registers 00 to 03, 10 to 13 (SCR00 to SCR03, SCR10 to SCR13)	0087H
	Serial channel enable status registers 0, 1 (SE0, SE1)	0000H
	Serial channel start registers 0, 1 (SS0, SS1)	0000H
	Serial channel stop registers 0, 1 (ST0, ST1)	0000H
	Serial clock select registers 0, 1 (SPS0, SPS1)	0000H
	Serial output registers 0, 1 (SO0, SO1)	0F0FH
	Serial output enable registers 0, 1 (SOE0, SOE1)	0000H
	Serial output level registers 0, 1 (SOL0, SOL1)	0000H
	Serial standby control register 0, 1 (SSC0, SSC1)	0000H
	Input switch control register (ISC)	00H

- Notes**
1. During reset signal generation or oscillation stabilization time wait, only the PC contents among the hardware statuses become undefined. All other hardware statuses remain unchanged after reset.
  2. The reset value of WDTE is determined by the option byte setting.

**Remark** The special function register (SFR) mounted depend on the product. See 3.1.4 **Special function registers (SFRs)** and 3.1.5 **Extended special function registers (2nd SFRs: 2nd Special Function Registers)**.

**Table 19-2. Hardware Statuses After Reset Acknowledgment (3/4)**

Hardware		Status After Reset Acknowledgment <sup>Note 1</sup>
Serial interface IICA	IICA shift register 0, 1 (IICA0, IICA1)	00H
	IICA status register 0, 1 (IICS0, IICS1)	00H
	IICA flag register 0, 1 (IICF0, IICF1)	00H
	IICA control register 00, 10 (IICCTL00, IICCTL10)	00H
	IICA control register 01, 11 (IICCTL01, IICCTL11)	00H
	IICA low-level width setting register 0, 1 (IICWL0, IICWL1)	FFH
	IICA high-level width setting register 0, 1 (IICWH0, IICWH1)	FFH
	Slave address register 0, 1 (SVA0, SVA1)	00H
Multiplier & divider, multiply-accumulator	Multiplication/division data register A (L) (MDAL)	0000H
	Multiplication/division data register A (H) (MDAH)	0000H
	Multiplication/division data register B (L) (MDBL)	0000H
	Multiplication/division data register B (H) (MDBH)	0000H
	Multiplication/division data register C (L) (MDCL)	0000H
	Multiplication/division data register C (H) (MDCH)	0000H
	Multiplication/division control register (MDUC)	00H
Key interrupt	Key return mode register (KRM)	00H

**Note** During reset signal generation or oscillation stabilization time wait, only the PC contents among the hardware statuses become undefined. All other hardware statuses remain unchanged after reset.

**Remark** The special function register (SFR) mounted depend on the product. See **3.1.4 Special function registers (SFRs)** and **3.1.5 Extended special function registers (2nd SFRs: 2nd Special Function Registers)**.

**Table 19-2. Hardware Statuses After Reset Acknowledgment (4/4)**

Hardware		Status After Reset Acknowledgment <sup>Note 1</sup>
Reset function	Reset control flag register (RESF)	Undefined <sup>Note 2</sup>
Voltage detector	Voltage detection register (LVIM)	00H <sup>Note 2</sup>
	Voltage detection level register (LVIS)	00H/01H/81H <sup>Notes 2, 3</sup>
DMA controller	SFR address registers 0 to 3 (DSA0 to DSA3)	00H
	RAM address registers 0 to 3 (DRA0 to DRA3)	0000H
	Byte count registers 0 to 3 (DBC0 to DBC3)	0000H
	Mode control registers 0 to 3 (DMC0 to DMC3)	00H
	Operation control registers 0 to 3 (DRC0 to DRC3)	00H
Interrupt	Request flag registers 0L, 0H, 1L, 1H, 2L, 2H, 3L (IF0L, IF0H, IF1L, IF1H, IF2L, IF2H, IF3L)	00H
	Mask flag registers 0L, 0H, 1L, 1H, 2L, 2H, 3L (MK0L, MK0H, MK1L, MK1H, MK2L, MK2H, MK3L)	FFH
	Priority specification flag registers 00L, 00H, 01L, 01H, 02L, 02H, 03L, 10L, 10H, 11L, 11H, 12L, 12H, 13L (PR00L, PR00H, PR01L, PR01H, PR10L, PR10H, PR11L, PR11H, PR02L, PR02H, PR12L, PR12H, PR03L, PR13L)	FFH
	External interrupt rising edge enable registers 0, 1 (EGP0, EGP1)	00H
	External interrupt falling edge enable registers 0, 1 (EGN0, EGN1)	00H
Safety functions	Flash memory CRC control register (CRC0CTL)	00H
	Flash memory CRC operation result register (PGCRCL)	0000H
	CRC input register (CCRIN)	00H
	CRC data register (CRCD)	0000H
	Invalid memory access detection control register (IAWCTL)	00H
	RAM parity error control register (RPECTL)	00H
Flash memory	Data flash control register (DFLCTL)	00H
BCD correction circuit	BCD correction result register (BCDAJ)	Undefined

(Notes and Remark are listed on the next page.)



- Notes**
1. During reset signal generation or oscillation stabilization time wait, only the PC contents among the hardware statuses become undefined. All other hardware statuses remain unchanged after reset.
  2. These values vary depending on the reset source.

Register \ Reset Source		RESET Input	Reset by POR	Reset by Execution of Illegal Instruction	Reset by WDT	Reset by RAM parity error	Reset by illegal-memory access	Reset by LVD
RESF	TRAP bit	Cleared (0)	Cleared (0)	Set (1)	Held	Held	Held	Held
	WDTRF bit			Held	Set (1)	Held	Held	Held
	RPERF bit			Held	Held	Set (1)	Held	Held
	IAWRF bit			Held	Held	Held	Set (1)	Held
	LVIRF bit			Held	Held	Held	Held	Set (1)
<R> LVIM	LVISEN	Cleared (0)	Cleared (0)	Cleared (0)	Cleared (0)	Cleared (0)	Cleared (0)	Held
<R> LVIS		Cleared (00H/01H/81H)	Cleared (00H/01H/81H)	Cleared (00H/01H/81H)	Cleared (00H/01H/81H)	Cleared (00H/01H/81H)	Cleared (00H/01H/81H)	Held

3. The generation of reset signal other than an LVD reset sets as follows.

- When option byte LVIMDS1, LVIMDS0 = 1, 0: 00H
- When option byte LVIMDS1, LVIMDS0 = 1, 1: 81H
- When option byte LVIMDS1, LVIMDS0 = 0, 1: 01H

**Remark** The special function register (SFR) mounted depend on the product. See **3.1.4 Special function registers (SFRs)** and **3.1.5 Extended special function registers (2nd SFRs: 2nd Special Function Registers)**.

## 19.1 Register for Confirming Reset Source

Many internal reset generation sources exist in the RL78/G13. The reset control flag register (RESF) is used to store which source has generated the reset request.

The RESF register can be read by an 8-bit memory manipulation instruction.

$\overline{\text{RESET}}$  input, reset by power-on-reset (POR) circuit, and reading the RESF register clear TRAP, WDTRF, RPERF, IAWRF, and LVIRF flags.

**Figure 19-5. Format of Reset Control Flag Register (RESF)**

Address: FFFA8H After reset: 00H<sup>Note 1</sup> R

Symbol	7	6	5	4	3	2	1	0
RESF	TRAP	0	0	WDTRF	0	RPERF	IAWRF	LVIRF

TRAP	Internal reset request by execution of illegal instruction <sup>Note 2</sup>
0	Internal reset request is not generated, or the RESF register is cleared.
1	Internal reset request is generated.

WDTRF	Internal reset request by watchdog timer (WDT)
0	Internal reset request is not generated, or the RESF register is cleared.
1	Internal reset request is generated.

RPERF	Internal reset request t by RAM parity
0	Internal reset request is not generated, or the RESF register is cleared.
1	Internal reset request is generated.

IAWRF	Internal reset request t by illegal-memory access
0	Internal reset request is not generated, or the RESF register is cleared.
1	Internal reset request is generated.

LVIRF	Internal reset request by voltage detector (LVD)
0	Internal reset request is not generated, or the RESF register is cleared.
1	Internal reset request is generated.

**Notes 1.** The value after reset varies depending on the reset source.

**2.** The illegal instruction is generated when instruction code FFH is executed.

Reset by the illegal instruction execution not issued by emulation with the in-circuit emulator or on-chip debug emulator.

**Cautions 1.** Do not read data by a 1-bit memory manipulation instruction.

**2.** An instruction code fetched from RAM is not subject to parity error detection while it is being executed. However, the data read by the instruction is subject to parity error detection.

**3.** Because the RL78's CPU executes lookahead due to the pipeline operation, the CPU might read an uninitialized RAM area that is allocated beyond the RAM used, which causes a RAM parity error. Therefore, when enabling RAM parity error resets (RPERDIS = 1), be sure to initialize the used RAM area + 10 bytes.

The status of the RESF register when a reset request is generated is shown in Table 19-3.

**Table 19-3. RESF Register Status When Reset Request Is Generated**

Reset Source Flag	$\overline{\text{RESET}}$ Input	Reset by POR	Reset by Execution of Illegal Instruction	Reset by WDT	Reset by RAM parity error	Reset by illegal- memory access	Reset by LVD
TRAP bit	Cleared (0)	Cleared (0)	Set (1)	Held	Held	Held	Held
WDTRF bit			Held	Set (1)	Held	Held	Held
RPERF bit			Held	Held	Set (1)	Held	Held
IAWRF bit			Held	Held	Held	Set (1)	Held
LVIRF bit			Held	Held	Held	Held	Set (1)

## CHAPTER 20 POWER-ON-RESET CIRCUIT

### 20.1 Functions of Power-on-reset Circuit

The power-on-reset circuit (POR) has the following functions.

- Generates internal reset signal at power on.  
The reset signal is released when the supply voltage ( $V_{DD}$ ) exceeds  $1.51\text{ V} \pm 0.03\text{ V}$ .
- Compares supply voltage ( $V_{DD}$ ) and detection voltage ( $V_{PDR} = 1.50\text{ V} \pm 0.03\text{ V}$ ), generates internal reset signal when  $V_{DD} < V_{PDR}$ .

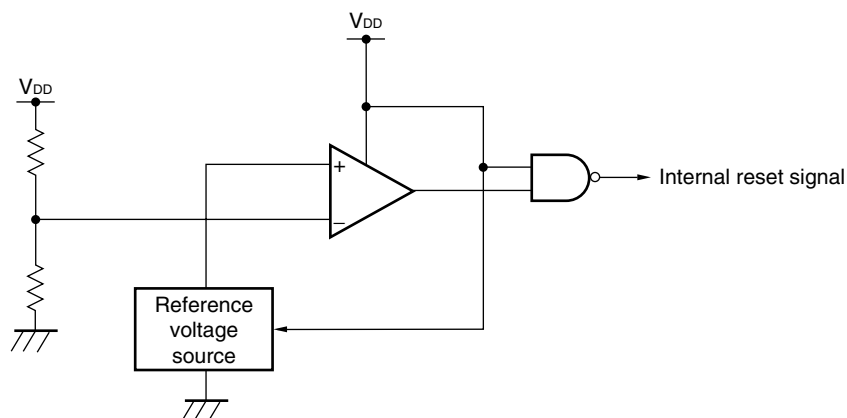
**Caution** If an internal reset signal is generated in the POR circuit, TRAP, WDTRF, RPERF, IAWRF, and LVIRF flags of the reset control flag register (RESF) is cleared.

**Remark** This product incorporates multiple hardware functions that generate an internal reset signal. A flag that indicates the reset source is located in the reset control flag register (RESF) for when an internal reset signal is generated by the watchdog timer (WDT), voltage-detector (LVD), illegal instruction execution, RAM parity error, or illegal-memory access. The RESF register is not cleared to 00H and the flag is set to 1 when an internal reset signal is generated by the watchdog timer (WDT), voltage-detector (LVD), illegal instruction execution, RAM parity error, or illegal-memory access.  
For details of the RESF register, see **CHAPTER 19 RESET FUNCTION**.

## 20.2 Configuration of Power-on-reset Circuit

The block diagram of the power-on-reset circuit is shown in Figure 20-1.

**Figure 20-1. Block Diagram of Power-on-reset Circuit**



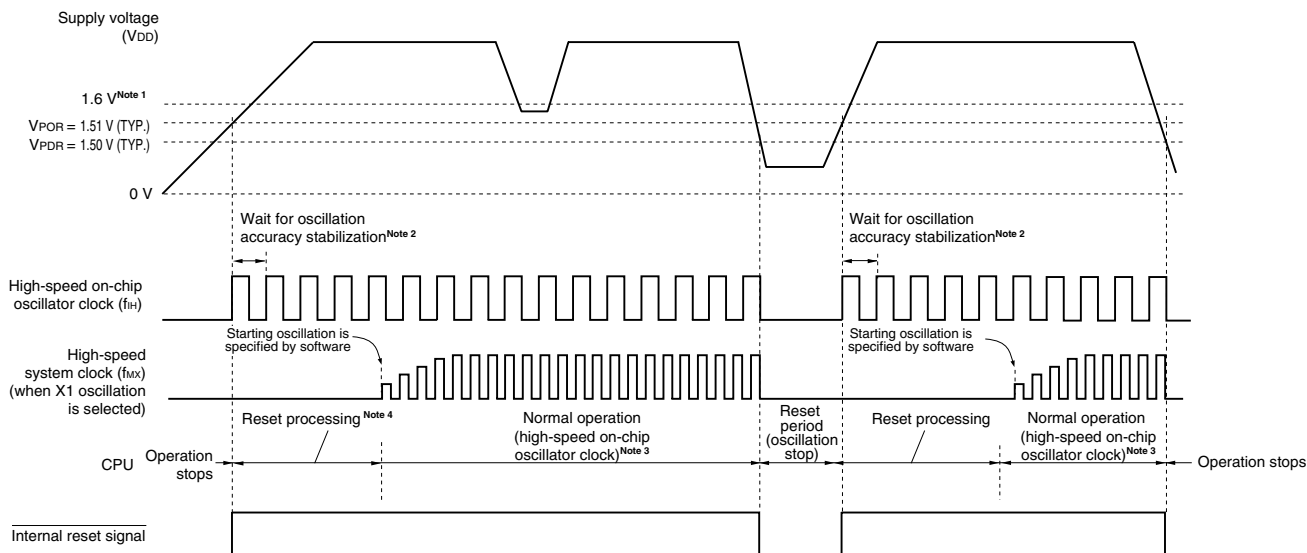
## 20.3 Operation of Power-on-reset Circuit

- An internal reset signal is generated on power application. When the supply voltage ( $V_{DD}$ ) exceeds the detection voltage ( $V_{PDR} = 1.51 \text{ V} \pm 0.03 \text{ V}$ ), the reset status is released.
- The supply voltage ( $V_{DD}$ ) and detection voltage ( $V_{PDR} = 1.50 \text{ V} \pm 0.03 \text{ V}$ ) are compared. When  $V_{DD} < V_{PDR}$ , the internal reset signal is generated.

The timing of generation of the internal reset signal by the power-on-reset circuit and voltage detector is shown below.

**Figure 20-2. Timing of Generation of Internal Reset Signal by Power-on-reset Circuit and Voltage Detector (1/2)**

<R> (1) When LVD is OFF (option byte 000C1H/010C1H: VPOC2 = 1B)



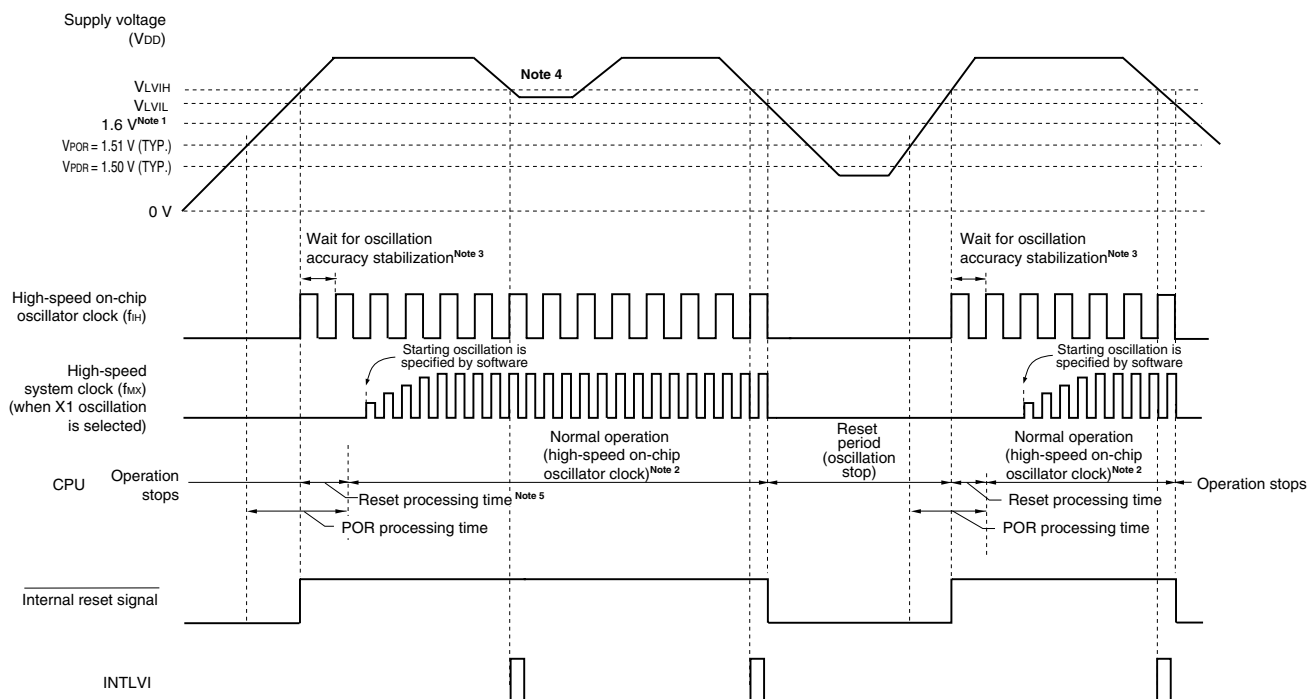
- Notes**
1. The operation guaranteed range is  $1.6\text{ V} \leq V_{DD} \leq 5.5\text{ V}$ . To make the state at lower than 1.6 V reset state when the supply voltage falls, use the reset function of the voltage detector, or input the low level to the  $\overline{\text{RESET}}$  pin.
  2. The internal reset processing time includes the oscillation accuracy stabilization time of the high-speed on-chip oscillator clock.
  3. The high-speed on-chip oscillator clock and a high-speed system clock or subsystem clock can be selected as the CPU clock. To use the X1 clock, use the oscillation stabilization time counter status register (OSTC) to confirm the lapse of the oscillation stabilization time. To use the XT1 clock, use the timer function for confirmation of the lapse of the stabilization time.

<R> 4. Reset processing time: 155 to 407  $\mu\text{s}$

**Remark** V<sub>POR</sub>: POR power supply rise detection voltage  
 V<sub>PDR</sub>: POR power supply fall detection voltage

**Figure 20-2. Timing of Generation of Internal Reset Signal by Power-on-reset Circuit and Voltage Detector (2/2)**

**(2) When LVD is interrupt & reset mode (option byte 000C1/010C1H: LVIMDS1, LVIMDS0 = 1, 0)**



**Notes 1.** The operation guaranteed range is  $1.6\text{ V} \leq V_{DD} \leq 5.5\text{ V}$ . To make the state at lower than 1.6 V reset state when the supply voltage falls, use the reset function of the voltage detector, or input the low level to the **RESET** pin.

**2.** The high-speed on-chip oscillator clock and a high-speed system clock or subsystem clock can be selected as the CPU clock. To use the X1 clock, use the oscillation stabilization time counter status register (OSTC) to confirm the lapse of the oscillation stabilization time. To use the XT1 clock, use the timer function for confirmation of the lapse of the stabilization time.

**3.** The internal reset processing time includes the oscillation accuracy stabilization time of the high-speed on-chip oscillator clock.

**4.** After the first interrupt request signal (INTLVI) is generated, the LVIL and LVIMD bits of the voltage detection level register (LVIS) are automatically set to 1. If the operating voltage returns to 1.6 V or higher without falling below the voltage detection level (V<sub>LVIL</sub>), after INTLVI is generated, perform the required backup processing, and then use software to specify the following settings in order:

<1> Clear the LVILV bit of the LVIS register to 0.

<2> Clear the LVIMD bit of the LVIS register to 0.

**5.** Reset processing time: 387 to 720  $\mu\text{s}$

**Remark** V<sub>LVIH</sub>, V<sub>LVIL</sub>: LVD detection voltage

V<sub>POR</sub>: POR power supply rise detection voltage

V<sub>PDR</sub>: POR power supply fall detection voltage

### 20.4 Cautions for Power-on-reset Circuit

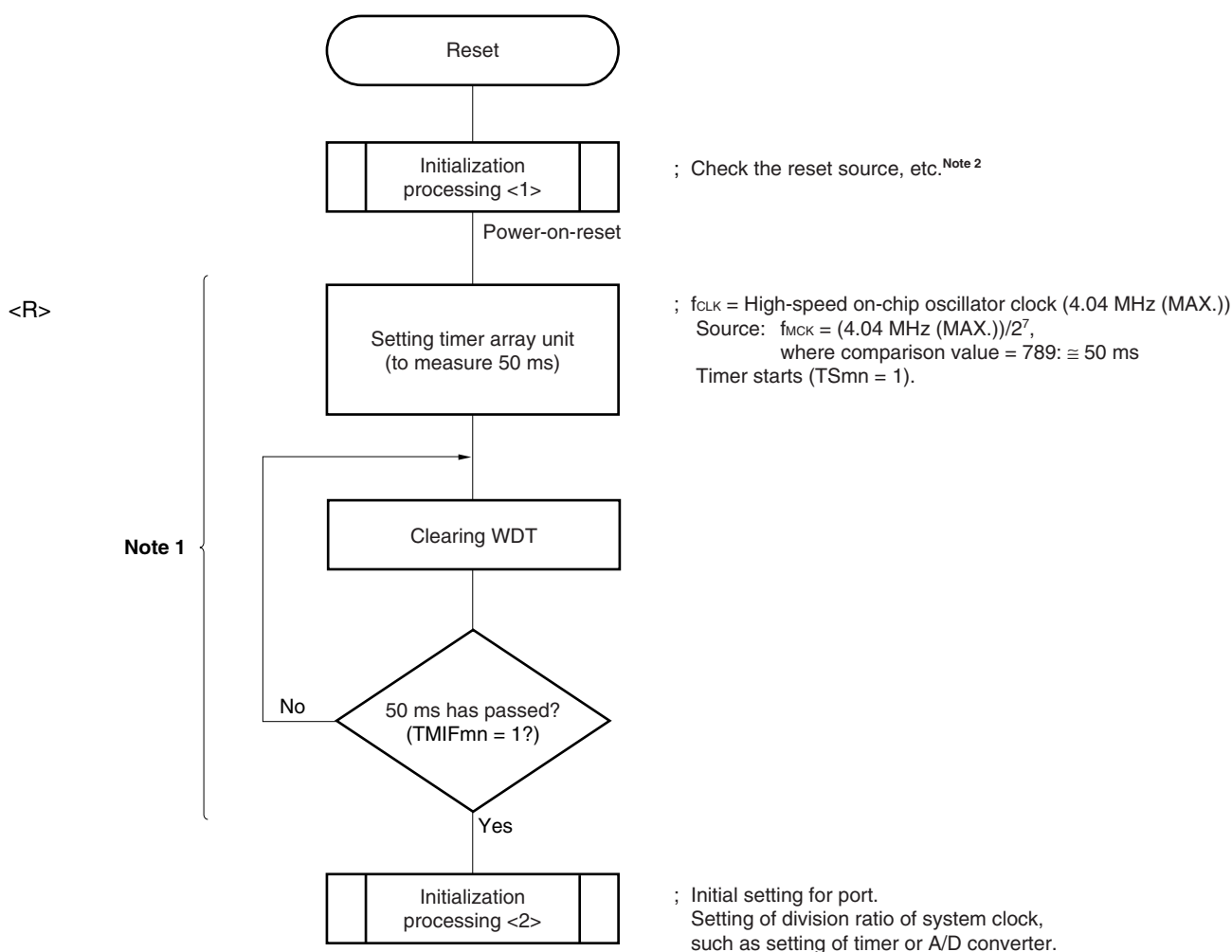
In a system where the supply voltage ( $V_{DD}$ ) fluctuates for a certain period in the vicinity of the POR detection voltage ( $V_{POR}$ ,  $V_{PDR}$ ), the system may be repeatedly reset and released from the reset status. In this case, the time from release of reset to the start of the operation of the microcontroller can be arbitrarily set by taking the following action.

<Action>

After releasing the reset signal, wait for the supply voltage fluctuation period of each system by means of a software counter that uses a timer, and then initialize the ports.

**Figure 20-3. Example of Software Processing After Reset Release (1/2)**

- If supply voltage fluctuation is 50 ms or less in vicinity of POR detection voltage



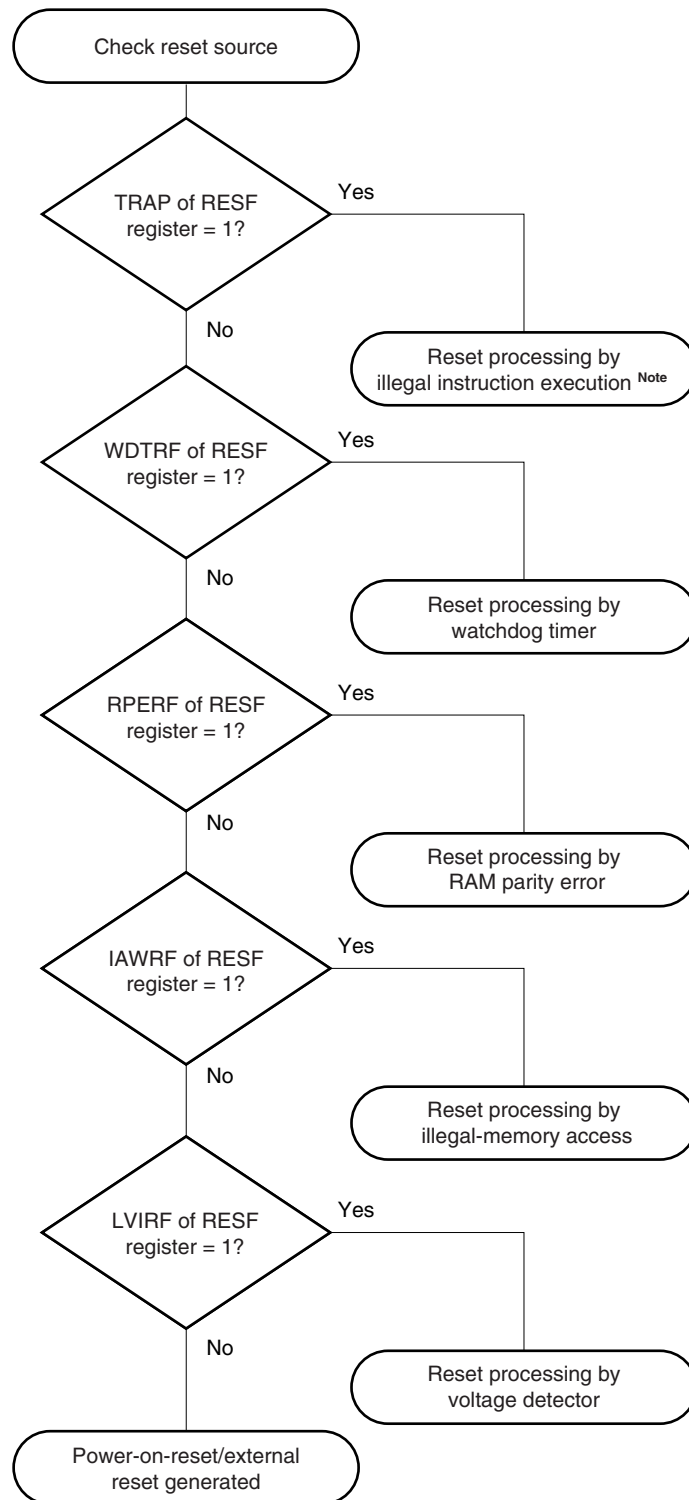
- Notes**
1. If reset is generated again during this period, initialization processing <2> is not started.
  2. A flowchart is shown on the next page.

**Remark** m = 0, 1  
n = 0 to 7



Figure 20-3. Example of Software Processing After Reset Release (2/2)

- Checking reset source



**Note** The illegal instruction is generated when instruction code FFH is executed. Reset by the illegal instruction execution not issued by emulation with the in-circuit emulator or on-chip debug emulator.

## CHAPTER 21 VOLTAGE DETECTOR

## 21.1 Functions of Voltage Detector

The voltage detector (LVD) has the following functions.

- The LVD circuit compares the supply voltage ( $V_{DD}$ ) with the detection voltage ( $V_{LVIH}$ ,  $V_{LVIL}$ ), and generates an internal reset or internal interrupt signal.
- The detection level for the power supply detection voltage ( $V_{LVIH}$ ,  $V_{LVIL}$ ) can be selected by using the option byte as one of 14 levels (For details, see **CHAPTER 24 OPTION BYTE**).
- Operable in STOP mode.
- The following three operation modes can be selected by using the option byte.

(a) Interrupt & reset mode (option byte LVIMDS1, LVIMDS0 = 1, 0)

For the two detection voltages selected by the option byte 000C1H/010C1H, the high-voltage detection level ( $V_{LVIH}$ ) is used for generating interrupts and ending resets, and the low-voltage detection level ( $V_{LVIL}$ ) is used for triggering resets.

(b) Reset mode (option byte LVIMDS1, LVIMDS0 = 1, 1)

The detection voltage ( $V_{LVI}$ ) selected by the option byte 000C1H/010C1H is used for triggering and ending resets.

<R> (c) Interrupt mode (option byte LVIMDS1, LVIMDS0 = 0, 1)

The detection voltage ( $V_{LVI}$ ) selected by the option byte 000C1H/010C1H is used for generating interrupts/reset release.

Two detection voltages ( $V_{LVIH}$ ,  $V_{LVIL}$ ) can be specified in the interrupt & reset mode, and one ( $V_{LVI}$ ) can be specified in the reset mode and interrupt mode.

The reset and interrupt signals are generated as follows according to the option byte (LVIMDS0, LVIMDS1) selection.

	Interrupt & reset mode (LVIMDS1, LVIMDS0 = 1, 0)	Reset mode (LVIMDS1, LVIMDS0 = 1, 1)	Interrupt mode (LVIMDS1, LVIMDS0 = 0, 1)
<R>	Generates an internal interrupt signal when $V_{DD} < V_{LVIH}$ , and an internal reset when $V_{DD} < V_{LVIL}$ . Releases the reset signal when $V_{DD} \geq V_{LVH}$ .	Generates an internal reset signal when $V_{DD} < V_{LVI}$ and releases the reset signal when $V_{DD} \geq V_{LVI}$ .	Generates an internal interrupt signal when $V_{DD}$ drops lower than $V_{LVI}$ ( $V_{DD} < V_{LVI}$ ) or when $V_{DD}$ becomes $V_{LVI}$ or higher ( $V_{DD} \geq V_{LVI}$ ). Releases the reset signal when $V_{DD} \geq V_{LVI}$ at power on.

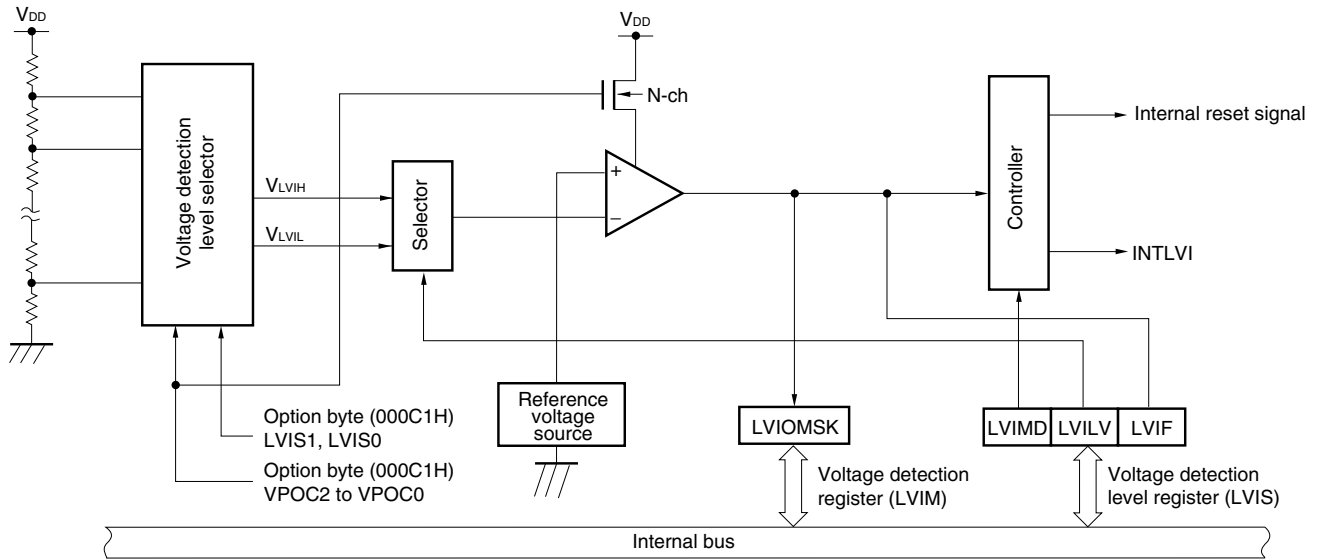
While the voltage detector is operating, whether the supply voltage or the input voltage from an external input pin is more than or less than the detection level can be checked by reading the voltage detection flag (LVIF: bit 0 of the voltage detection register (LVIM)).

Bit 0 (LVIRF) of the reset control flag register (RESF) is set to 1 if reset occurs. For details of the RESF register, see **CHAPTER 19 RESET FUNCTION**.

### 21.2 Configuration of Voltage Detector

The block diagram of the voltage detector is shown in Figure 21-1.

Figure 21-1. Block Diagram of Voltage Detector



### 21.3 Registers Controlling Voltage Detector

The voltage detector is controlled by the following registers.

- Voltage detection register (LVIM)
- Voltage detection level register (LVIS)

**(1) Voltage detection register (LVIM)**

This register is used to specify whether to enable or disable rewriting the voltage detection level register (LVIS), as well as to check the LVD output mask status.

This register can be set by a 1-bit or 8-bit memory manipulation instruction.

Reset signal generation clears this register to 00H.

**Figure 21-2. Format of Voltage Detection Register (LVIM)**

Address: FFFA9H After reset: 00H <sup>Note 1</sup> R/W <sup>Note 2</sup>

Symbol	<7>	6	5	4	3	2	<1>	<0>
LVIM	LVISEN	0	0	0	0	0	LVIOMSK	LVIF

LVISEN	Specification of whether to enable or disable rewriting the voltage detection level register (LVIS)
0	Disabling rewriting
1	Enabling rewriting <sup>Note 3</sup>

LVIOMSK	Mask status flag of LVD output
0	Mask is invalid
1	Mask is valid <sup>Note 4</sup>

LVIF	Voltage detection flag
0	Supply voltage ( $V_{DD}$ ) $\geq$ detection voltage ( $V_{LVI}$ ), or when LVD operation is disabled
1	Supply voltage ( $V_{DD}$ ) $<$ detection voltage ( $V_{LVI}$ )

- Notes**
1. The reset value changes depending on the reset source.  
If the LVIS register is reset by LVD, it is not reset but holds the current value.
  2. Bits 0 and 1 are read-only.
  3. This can only be set when LVIMDS1 and LVIMDS0 are set to 1 and 0 (interrupt and reset mode) by the option byte.
  4. LVIOMSK bit is automatically set to "1" in the following periods and reset or interruption by LVD is masked.
    - Period during LVISEN = 1
    - Waiting period from the time when LVD interrupt is generated until LVD detection voltage becomes stable
    - Waiting period from the time when the value of LVILV bit changes until LVD detection voltage becomes stable

<R>

<R>

<R>

**(2) Voltage detection level register (LVIS)**

This register selects the voltage detection level.

This register can be set by a 1-bit or 8-bit memory manipulation instruction.

Reset signal generation input sets this register to 00H/01H/81H <sup>Note1</sup>.

**Figure 21-3. Format of Voltage Detection Level Select Register (LVIS)**

Address: FFFAAH    After reset: 00H/01H/81H <sup>Note 1</sup>    R/W

Symbol	<7>	6	5	4	3	2	1	<0>
LVIS	LVIMD	0	0	0	0	0	0	LVILV

LVIMD <sup>Note 2</sup>	Operation mode of voltage detection
0	Interrupt mode
1	Reset mode

LVILV <sup>Note 2</sup>	LVD detection level
0	High-voltage detection level (V <sub>LVIH</sub> )
1	Low-voltage detection level (V <sub>LVIL</sub> or V <sub>LVIL</sub> )

**Notes 1.** The reset value changes depending on the reset source and the setting of the option byte.

This register is not cleared (00H) by LVD reset.

The generation of reset signal other than an LVD reset sets as follows.

- When option byte LVIMDS1, LVIMDS0 = 1, 0: 00H
- When option byte LVIMDS1, LVIMDS0 = 1, 1: 81H
- When option byte LVIMDS1, LVIMDS0 = 0, 1: 01H

**2.** Writing “0” can only be allowed when LVIMDS1 and LVIMDS0 are set to 1 and 0 (interrupt and reset mode) by the option byte. In other cases, writing is not allowed and the value is switched automatically when reset or interrupt is generated.

**Cautions 1.** Only rewrite the value of the LVIS register after setting the LVISEN bit (bit 7 of the LVIM register) to 1.

**2.** Specify the LVD operation mode and detection voltage (V<sub>LVIH</sub>, V<sub>LVIL</sub>) by using the option byte (000C1H). Table 21-1 shows the option byte (000C1H) settings. For details about the option byte, see **CHAPTER 24 OPTION BYTE**.

**Table 21-1. LVD Operation Mode and Detection Voltage Settings for User Option Byte (000C1H/010C1H)**

- When used as interrupt & reset mode

Detection voltage			Option byte Setting Value												
V <sub>LVIH</sub>		V <sub>LVIL</sub>	LVIMDS1	LVIMDS0	VPOC2	VPOC1	VPOC0	LVIS1	LVIS0						
Rising edge	Falling edge	Falling edge													
1.77 V	1.73 V	1.63 V	1	0	0	0	0	1	0						
1.88 V	1.84 V							0	1						
2.92 V	2.86 V							0	0						
1.98 V	1.94 V	1.84 V			1	0	0	0	1	1	0				
2.09 V	2.04 V									0	1				
3.13 V	3.06 V									0	0				
2.61 V	2.55 V	2.45 V					1	0	0	1	0	1	0		
2.71 V	2.65 V											0	1		
3.75 V	3.67 V											0	0		
2.92 V	2.86 V	2.75 V							1	0	0	1	1	1	0
3.02 V	2.96 V													0	1
4.06 V	3.98 V													0	0
Other than above			Setting prohibited												

- When used as reset mode

<R>

Detection voltage			Option byte Setting Value								
V <sub>LVI</sub>		LVIMDS1	LVIMDS0	VPOC2	VPOC1	VPOC0	LVIS1	LVIS0			
Rising edge	Falling edge										
1.67 V	1.63 V	1	1	0	0	0	1	1			
1.77 V	1.73 V			0	0	0	1	0			
1.88 V	1.84 V			0	0	1	1	1			
1.98 V	1.94 V			0	0	1	1	0			
2.09 V	2.04 V			0	0	1	0	1			
2.50 V	2.45 V			0	1	0	1	1			
2.61 V	2.55 V			0	1	0	1	0			
2.71 V	2.65 V			0	1	0	0	1			
2.81 V	2.75 V			0	1	1	1	1			
2.92 V	2.86 V			0	1	1	1	0			
3.02 V	2.96 V			0	1	1	0	1			
3.13 V	3.06 V			0	0	1	0	0			
3.75 V	3.67 V			0	1	0	0	0			
4.06 V	3.98 V			0	1	1	0	0			
Other than above				Setting prohibited							

- When used as interrupt mode

Detection voltage		Option byte Setting Value						
V <sub>LVI</sub>		LVIMDS1	LVIMDS0	VPOC2	VPOC1	VPOC0	LVIS1	LVIS0
Rising edge	Falling edge							
1.67 V	1.63 V	0	1	0	0	0	1	1
1.77 V	1.73 V			0	0	0	1	0
1.88 V	1.84 V			0	0	1	1	1
1.98 V	1.94 V			0	0	1	1	0
2.09 V	2.04 V			0	0	1	0	1
2.50 V	2.45 V			0	1	0	1	1
2.61 V	2.55 V			0	1	0	1	0
2.71 V	2.65 V			0	1	0	0	1
2.81 V	2.75 V			0	1	1	1	1
2.92 V	2.86 V			0	1	1	1	0
3.02 V	2.96 V			0	1	1	0	1
3.13 V	3.06 V			0	0	1	0	0
3.75 V	3.67 V			0	1	0	0	0
4.06 V	3.98 V			0	1	1	0	0
Other than above				Setting prohibited				

- When LVDOFF

Detection voltage		Option byte Setting Value						
V <sub>LVI</sub>		LVIMDS1	LVIMDS0	VPOC2	VPOC1	VPOC0	LVIS1	LVIS0
Rising edge	Falling edge							
–	–	0/1	1	1	×	×	×	×
Other than above		Setting prohibited						

**Remark** ×: don't care

## 21.4 Operation of Voltage Detector

### 21.4.1 When used as reset mode

- When starting operation

Start in the following initial setting state.

Specify the operation mode (the reset mode (LVIMDS1, LVIMDS0 = 1, 1)) and the detection voltage ( $V_{LVI}$ ) by using the option byte 000C1H/010C1H.

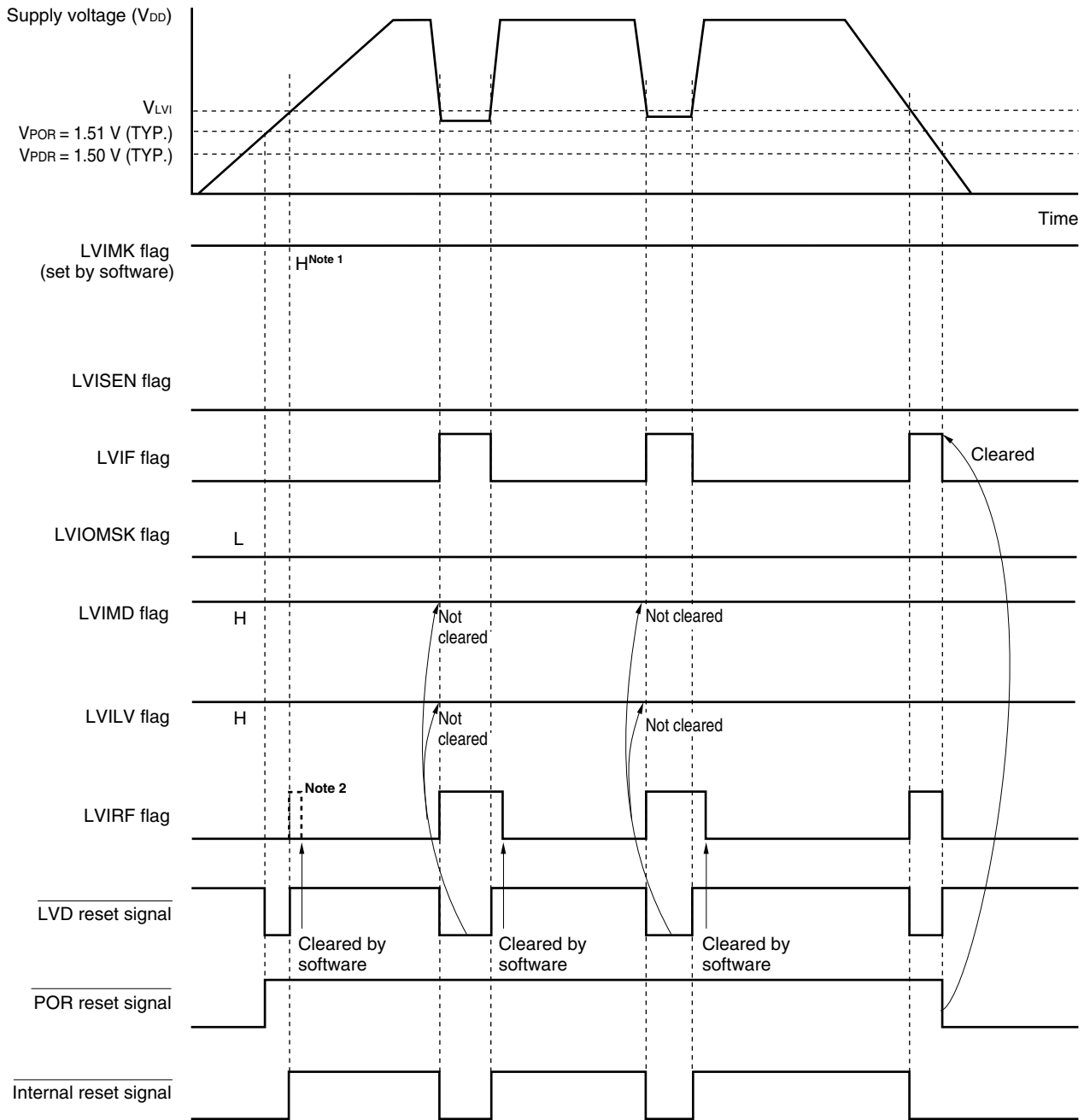
- <R>
- Set bit 7 (LVISEN) of the voltage detection register (LVIM) to 0 (disable rewriting of voltage detection level register (LVIS))
  - When the option byte LVIMDS1 and LVIMDS0 are set to 1, the initial value of the LVIS register is set to 81H.  
Bit 7 (LVIMD) is 1 (reset mode).  
Bit 0 (LVILV) is 1 (low-voltage detection level:  $V_{LVI}$ ).

Figure 21-4 shows the timing of the internal reset signal generated by the voltage detector.



<R>

**Figure 21-4. Timing of Voltage Detector Internal Reset Signal Generation  
(Option Byte LVIMDS1, LVIMDS0 = 1, 1)**



- Notes**
1. The LVIMK flag is set to "1" by reset signal generation.
  2. LVIRF flag is bit 0 of the reset control flag register (RESF).  
The LVIRF flag may become 1 from the beginning due to the power-on waveform.  
For details of the RESF register, see **CHAPTER 19 RESET FUNCTION**.

**Remark**  $V_{POR}$ : POR power supply rise detection voltage  
 $V_{PDR}$ : POR power supply fall detection voltage

### 21.4.2 When used as interrupt mode

- When starting operation

Specify the operation mode (the interrupt mode (LVIMDS1, LVIMDS0 = 0, 1)) and the detection voltage ( $V_{LVI}$ ) by using the option byte 000C1H/010C1H.

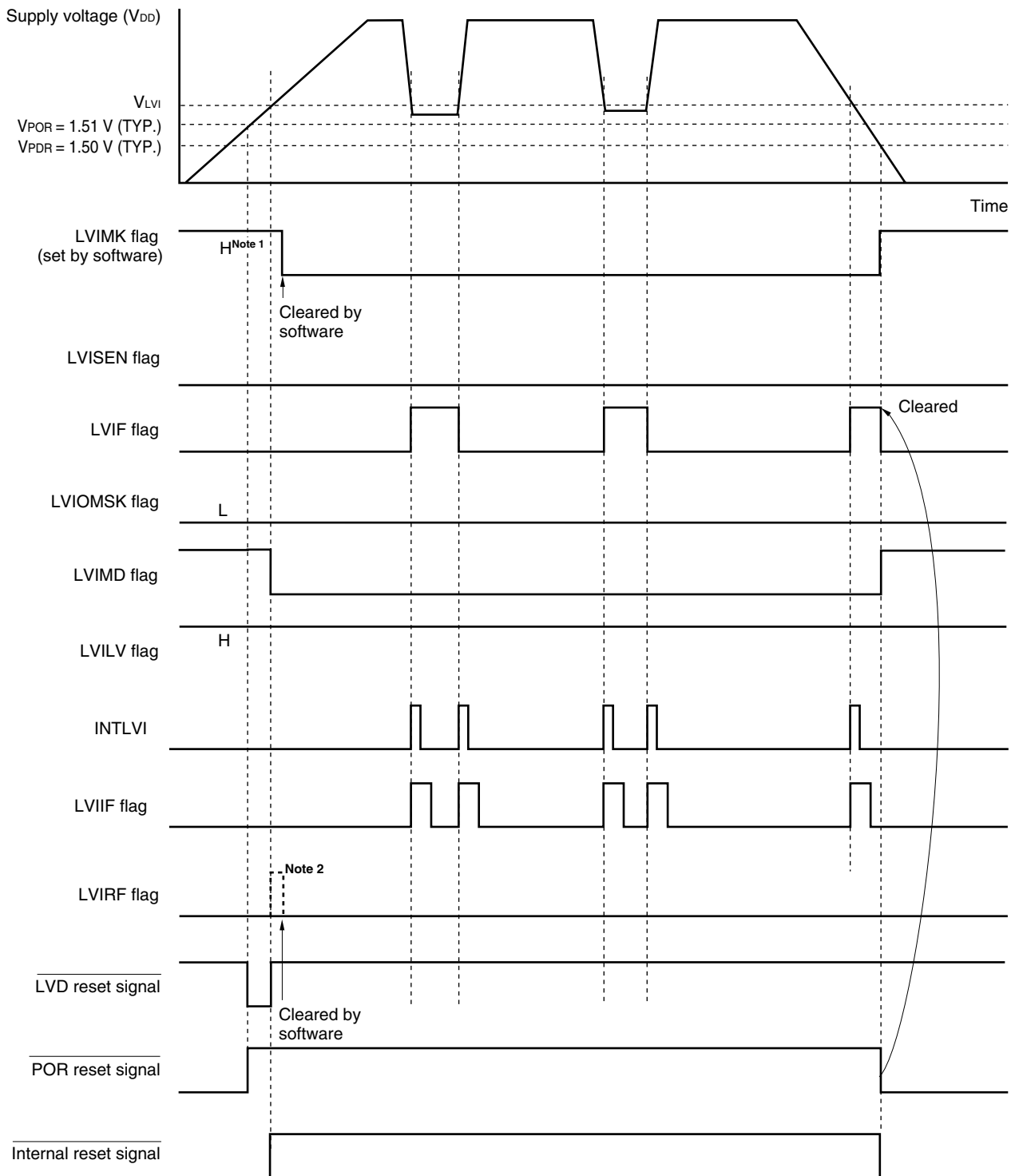
Start in the following initial setting state.

- <R>
- Set bit 7 (LVISEN) of the voltage detection register (LVIM) to 0 (disable rewriting of voltage detection level register (LVIS))
  - When the option byte LVIMDS1 is clear to 0 and LVIMDS0 is set to 1, the initial value of the LVIS register is set to 00H.
    - Bit 7 (LVIMD) is 0 (interrupt mode).
    - Bit 0 (LVILV) is 1 (low-voltage detection level:  $V_{LVI}$ ).

Figure 21-5 shows the timing of the internal interrupt signal generated by the voltage detector.

<R>

**Figure 21-5. Timing of Voltage Detector Internal Interrupt Signal Generation  
(Option Byte LVIMDS1, LVIMDS0 = 0, 1)**



- Notes**
1. The LVIMK flag is set to “1” by reset signal generation.
  2. LVIRF flag is bit 0 of the reset control flag register (RESF).  
The LVIRF flag may become 1 from the beginning due to the power-on waveform.  
For details of the RESF register, see **CHAPTER 19 RESET FUNCTION**.

**Remark** V<sub>POR</sub>: POR power supply rise detection voltage  
V<sub>PDR</sub>: POR power supply fall detection voltage

### 21.4.3 When used as interrupt and reset mode

- When starting operation

Specify the operation mode (the interrupt and reset (LVIMDS1, LVIMDS0 = 1, 0)) and the detection voltage ( $V_{LVIH}$ ,  $V_{LVIL}$ ) by using the option byte 000C1H/010C1H.

Start in the following initial setting state.

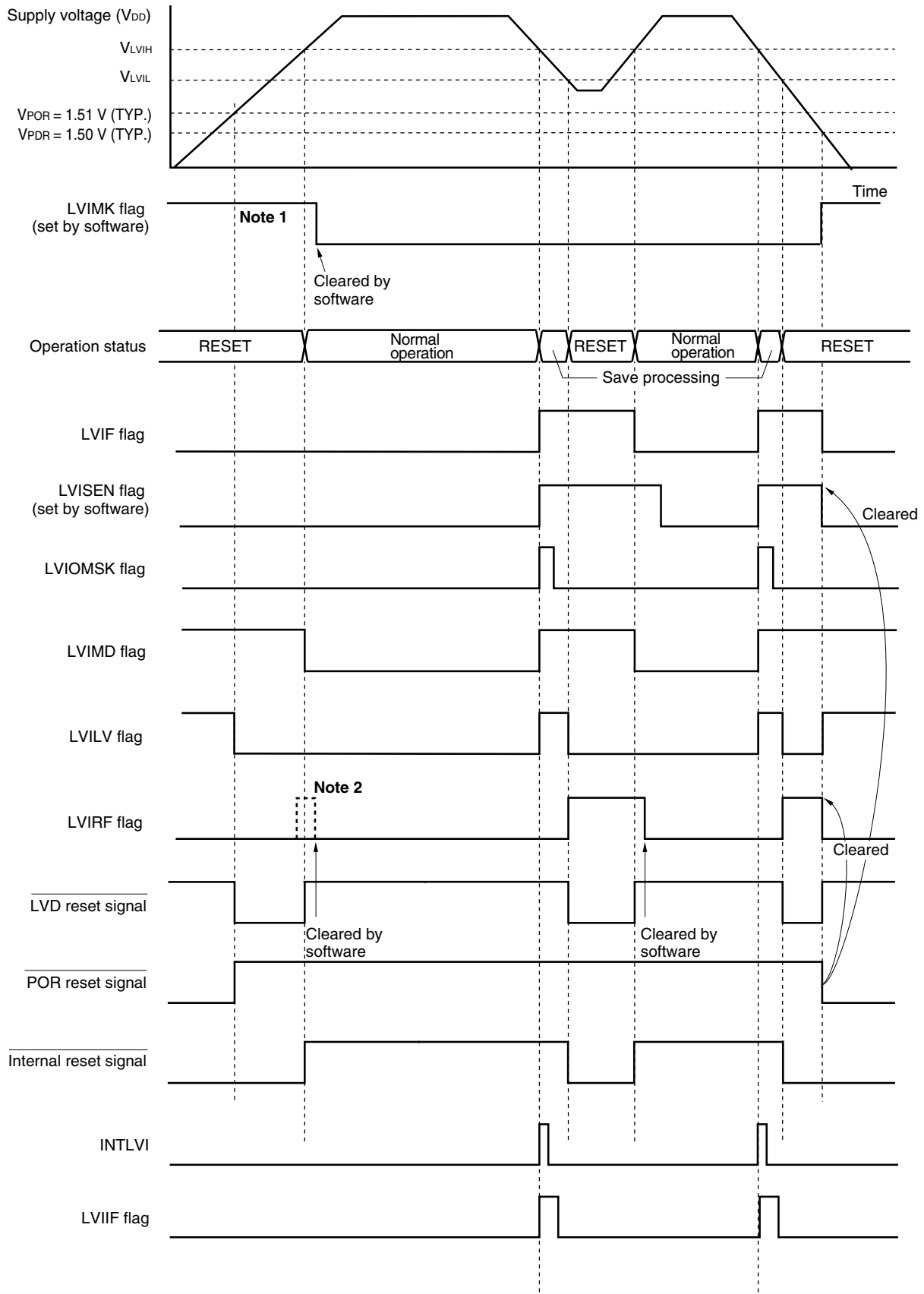
- <R>
- Set bit 7 (LVISEN) of the voltage detection register (LVIM) to 0 (disable rewriting of voltage detection level register (LVIS))
  - When the option byte LVIMDS1 is set to 1 and LVIMDS0 is clear to 0, the initial value of the LVIS register is set to 00H.
    - Bit 7 (LVIMD) is 0 (interrupt mode).
    - Bit 0 (LVILV) is 0 (high-voltage detection level:  $V_{LVIH}$ ).

**Caution** The LVIRF flag may become 1 from the beginning due to the power-on waveform.  
For details of the RESF register, see CHAPTER 19 RESET FUNCTION.

Figure 21-6 shows the timing of the internal reset signal and interrupt signal generated by the voltage detector.

<R>

**Figure 21-6. Timing of Voltage Detector Reset Signal and Interrupt Signal Generation  
(Option Byte LVIMDS1, LVIMDS0 = 1, 0)**



(Notes and Remark are listed on the next page.)

- Notes**
1. The LVIMK flag is set to “1” by reset signal generation.
  2. LVIRF flag is bit 0 of the reset control flag register (RESF).  
The LVIRF flag may become 1 from the beginning due to the power-on waveform.  
For details of the RESF register, see **CHAPTER 19 RESET FUNCTION**.

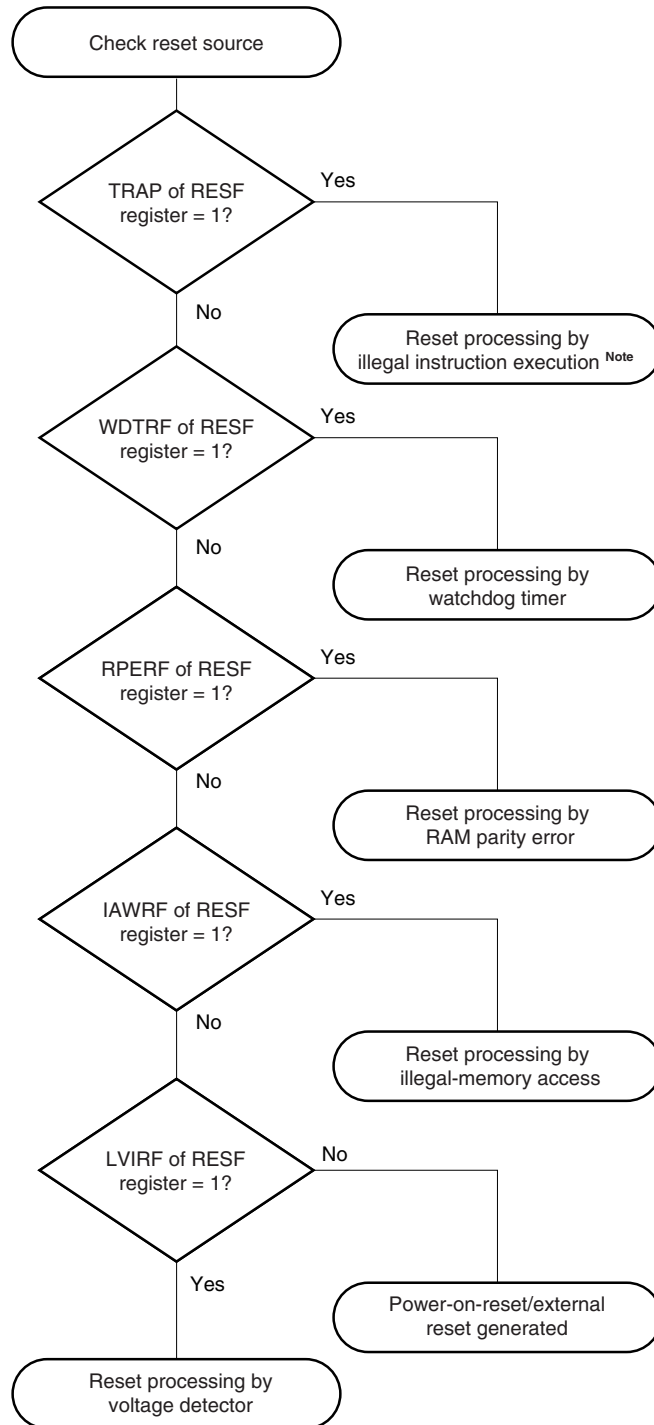
**Remark**  $V_{POR}$ : POR power supply rise detection voltage  
 $V_{PDR}$ : POR power supply fall detection voltage

### 21.5 Cautions for Voltage Detector

#### (1) Checking reset source

When a reset occurs, check the reset source by using the following method.

**Figure 21-7. Checking reset source**



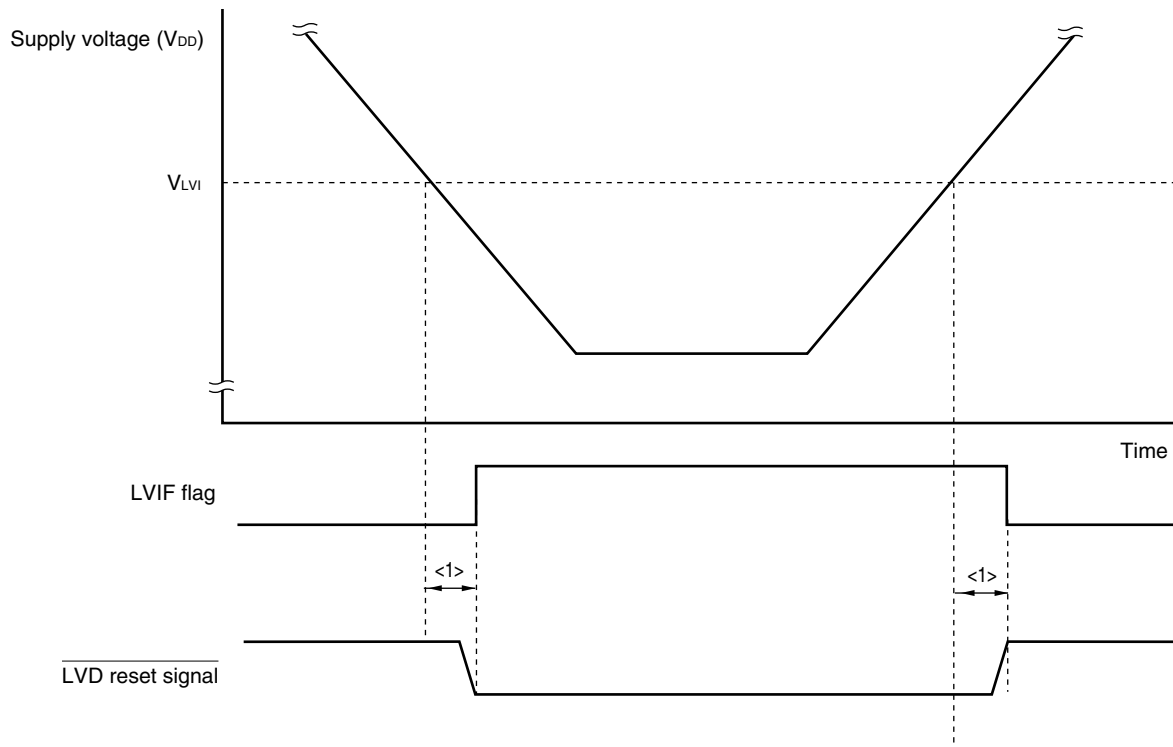
**Note** When instruction code FFH is executed.  
 Reset by the illegal instruction execution not issued by emulation with the in-circuit emulator or on-chip debug emulator.

**(2) Delay from the time LVD reset source is generated until the time LVD reset has been generated or released**

There is some delay from the time supply voltage ( $V_{DD}$ ) < LVD detection voltage ( $V_{LVI}$ ) until the time LVD reset has been generated.

In the same way, there is also some delay from the time LVD detection voltage ( $V_{LVI}$ )  $\leq$  supply voltage ( $V_{DD}$ ) until the time LVD reset has been released (see **Figure 21-8**).

**Figure 21-8. Delay from the time LVD reset source is generated until the time LVD reset has been generated or released**



<R> <1>: Detection delay (300  $\mu$ s (MAX.))



&lt;R&gt;

**CHAPTER 22 SAFETY FUNCTIONS****22.1 Overview of Safety Functions**

The following safety functions are provided in the RL78/G13 to comply with the IEC60730 and IEC61508 safety standards.

These functions enable the microcontroller to self-diagnose abnormalities and stop operating if an abnormality is detected.

**(1) Flash memory CRC operation function (high-speed CRC, general-purpose CRC)**

This detects data errors in the flash memory by performing CRC operations.

Two CRC functions are provided in the RL78/G13 that can be used according to the application or purpose of use.

- High-speed CRC: The CPU can be stopped and a high-speed check executed on its entire code flash memory area during the initialization routine.
- General CRC: This can be used for checking various data in addition to the code flash memory area while the CPU is running.

**(2) RAM parity error detection function**

This detects parity errors when the RAM is read as data.

**(3) RAM guard function**

This prevents RAM data from being rewritten when the CPU freezes.

**(4) SFR guard function**

This prevents SFRs from being rewritten when the CPU freezes.

**(5) Invalid memory access detection function**

This detects illegal accesses to invalid memory areas (such as areas where no memory is allocated and areas to which access is restricted).

**(6) Frequency detection function**

This uses TAU to detect the oscillation frequency.

**(7) A/D test function**

This is used to perform a self-check of A/D conversion by performing A/D conversion on the internal reference voltage.

**Remark** See the application note (currently under preparation) for the features required to comply with the IEC60730 and IEC61508 standards.

## 22.2 Registers Used by Safety Functions

The safety functions use the following registers for each function.

Register	Each Function of Safety Function
<ul style="list-style-type: none"> <li>Flash memory CRC control register (CRC0CTL)</li> <li>Flash memory CRC operation result register (PGCRCL)</li> </ul>	Flash memory CRC operation function (high-speed CRC)
<ul style="list-style-type: none"> <li>CRC input register (CRCIN)</li> <li>CRC data register (CRCD)</li> </ul>	CRC operation function (general-purpose CRC)
<ul style="list-style-type: none"> <li>RAM parity error control register (RPECTL)</li> </ul>	RAM parity error detection function
<ul style="list-style-type: none"> <li>Invalid memory access detection control register (IAWCTL)</li> </ul>	RAM guard function
	SFR guard function
	Invalid memory access detection function
<ul style="list-style-type: none"> <li>Timer input select register 0 (TIS0)</li> </ul>	Frequency detection function
<ul style="list-style-type: none"> <li>A/D test register (ADTES)</li> </ul>	A/D test function

The content of each register is described in **22.3 Operation of Safety Functions**.

## 22.3 Operation of Safety Functions

### 22.3.1 Flash memory CRC operation function (high-speed CRC)

The IEC60730 standard mandates the checking of data in the flash memory, and recommends using CRC to do it. The high-speed CRC provided in the RL78/G13 can be used to check the entire code flash memory area during the initialization routine. The high-speed CRC can be executed only when the program is allocated on the RAM and in the HALT mode of the main system clock.

The main feature of this check is that it does not take a long time. (For example, it only takes 512  $\mu$ s to check a 64 KB flash memory using a 32 MHz clock.)

The CRC generator polynomial used complies with “ $X^{16} + X^{12} + X^5 + 1$ ” of CRC-16-CCITT.

The high-speed CRC operates in MSB first order from bit 31 to bit 0.

**Remark** The operation result is different between the high-speed CRC and the general CRC, because the general CRC operates in LSB first order.

#### <Control register>

##### (1) Flash memory CRC control register (CRC0CTL)

This register is used to control the operation of the high-speed CRC ALU, as well as to specify the operation range.

The CRC0CTL register can be set by a 1-bit or 8-bit memory manipulation instruction.

Reset signal generation clears this register to 00H.

**Figure 22-1. Format of Flash Memory CRC Control Register (CRC0CTL) (1/2)**

Address: F02F0H After reset: 00H R/W

Symbol	<7>	6	5	4	3	2	1	0
CRC0CTL	CRC0EN	0	FEA5	FEA4	FEA3	FEA2	FEA1	FEA0

CRC0EN	Control of CRC ALU operation
0	Stop the operation.
1	Start the operation according to HALT instruction execution.

**Figure 22-1. Format of Flash Memory CRC Control Register (CRCOCTL) (2/2)**

Address: F02F0H After reset: 00H R/W

Symbol	<7>	6	5	4	3	2	1	0
CRCOCTL	CRC0EN	0	FEA5	FEA4	FEA3	FEA2	FEA1	FEA0

FEA5	FEA4	FEA3	FEA2	FEA1	FEA0	High-speed CRC operation range
0	0	0	0	0	0	0 to 3FFBH (16 K to 4 bytes)
0	0	0	0	0	1	0 to 7FFBH (32 K to 4 bytes)
0	0	0	0	1	0	0 to BFFBH (48 K to 4 bytes)
0	0	0	0	1	1	0 to FFFBH (64 K to 4 bytes)
0	0	0	1	0	0	0 to 13FFBH (80 K to 4 bytes)
0	0	0	1	0	1	0 to 17FFBH (96 K to 4 bytes)
0	0	0	1	1	0	0 to 1BFFBH (112 K to 4 bytes)
0	0	0	1	1	1	0 to 1FFFBH (128 K to 4 bytes)
0	0	1	0	0	0	0 to 23FFBH (144 K to 4 bytes)
0	0	1	0	0	1	0 to 27FFBH (160 K to 4 bytes)
0	0	1	0	1	0	0 to 2BFFBH (176 K to 4 bytes)
0	0	1	0	1	1	0 to 2FFFBH (192 K to 4 bytes)
0	0	1	1	0	0	0 to 33FFBH (208 K to 4 bytes)
0	0	1	1	0	1	0 to 37FFBH (224 K to 4 bytes)
0	0	1	1	1	0	0 to 3BFFBH (240 K to 4 bytes)
0	0	1	1	1	1	0 to 3FFFBH (256 K to 4 bytes)
0	1	0	0	0	0	0 to 43FFBH (272 K to 4 bytes)
0	1	0	0	0	1	0 to 47FFBH (288 K to 4 bytes)
0	1	0	0	1	0	0 to 4BFFBH (304 K to 4 bytes)
0	1	0	0	1	1	0 to 4FFFBH (320 K to 4 bytes)
0	1	0	1	0	0	0 to 53FFBH (336 K to 4 bytes)
0	1	0	1	0	1	0 to 57FFBH (352 K to 4 bytes)
0	1	0	1	1	0	0 to 5BFFBH (368 K to 4 bytes)
0	1	0	1	1	1	0 to 5FFFBH (384 K to 4 bytes)
0	1	1	0	0	0	0 to 63FFBH (400 K to 4 bytes)
0	1	1	0	0	1	0 to 67FFBH (416 K to 4 bytes)
0	1	1	0	1	0	0 to 6BFFBH (432 K to 4 bytes)
0	1	1	0	1	1	0 to 6FFFBH (448 K to 4 bytes)
0	1	1	1	0	0	0 to 73FFBH (464 K to 4 bytes)
0	1	1	1	0	1	0 to 77FFBH (480 K to 4 bytes)
0	1	1	1	1	0	0 to 7BFFBH (496 K to 4 bytes)
0	1	1	1	1	1	0 to 7FFFBH (512 K to 4 bytes)
Other than the above						Setting prohibited

**Remark** Input the expected CRC operation result value to be used for comparison in the lowest 4 bytes of the flash memory. Note that the operation range will thereby be reduced by 4 bytes.

**(2) Flash memory CRC operation result register (PGCRCL)**

This register is used to store the high-speed CRC operation results.

The PGCRCL register can be set by a 16-bit memory manipulation instruction.

Reset signal generation clears this register to 0000H.

**Figure 22-2. Format of Flash Memory CRC Operation Result Register (PGCRCL)**

Address: F02F2H After reset: 0000H R/W

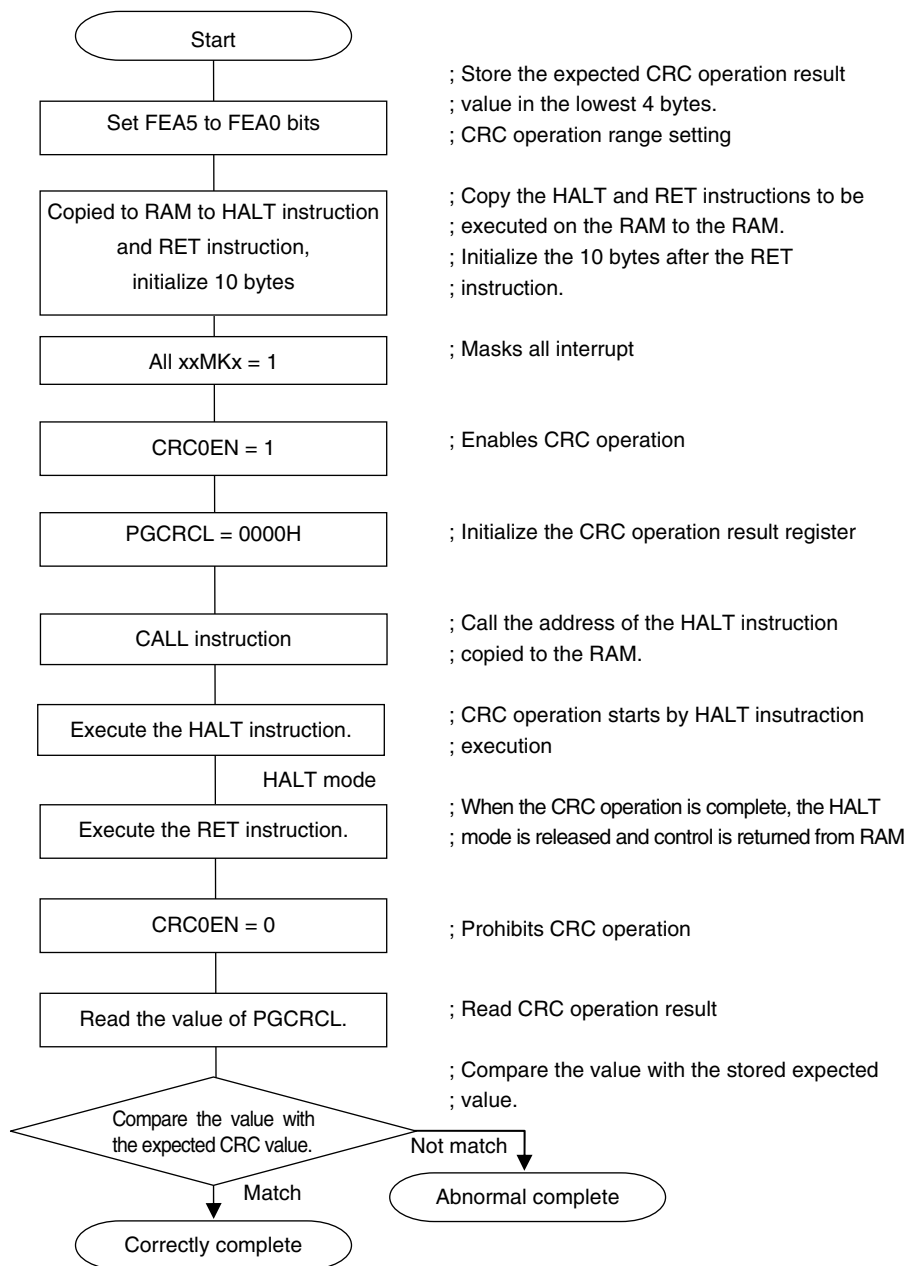
Symbol	15	14	13	12	11	10	9	8
PGCRCL	PGCRC15	PGCRC14	PGCRC13	PGCRC12	PGCRC11	PGCRC10	PGCRC9	PGCRC8
	7	6	5	4	3	2	1	0
	PGCRC7	PGCRC6	PGCRC5	PGCRC4	PGCRC3	PGCRC2	PGCRC1	PGCRC0
	PGCRC15 to 0		High-speed CRC operation results					
	0000H to FFFFH		Store the high-speed CRC operation results.					

**Caution** The PGCRCL register can only be written if CRC0EN (bit 7 of the CRC0CTL register) = 1.

Figure 22-3 shows the flowchart of flash memory CRC operation function (high-speed CRC).

<Operation flow>

Figure 22-3. Flowchart of Flash Memory CRC Operation Function (High-speed CRC)



- Cautions**
1. The CRC operation is executed only on the code flash.
  2. Store the expected CRC operation value in the area below the operation range in the code flash.
  3. Boot swapping is not performed while the CRC operation is being executed.
  4. The CRC operation is enabled by executing the HALT instruction in the RAM area.  
Be sure to execute the HALT instruction in RAM area.

The expected CRC value can be calculated by using tools such as the CubeSuite development environment. (See the CubeSuite user's manual for details.)

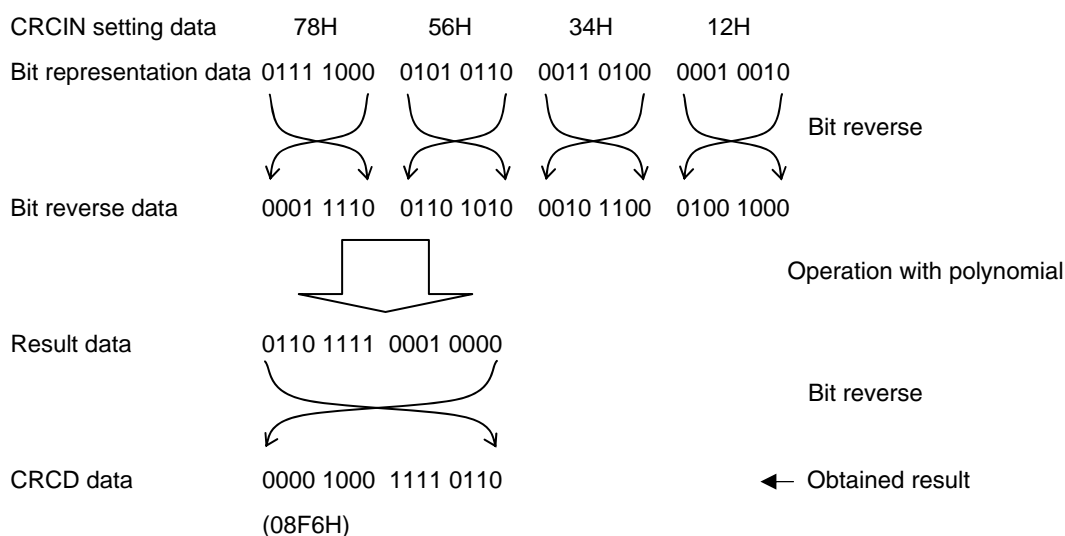
**22.3.2 CRC operation function (general-purpose CRC)**

In order to guarantee safety during operation, the IEC61508 standard mandates the checking of data even while the CPU is operating.

In the RL78/G13, a general CRC operation can be executed as a peripheral function while the CPU is operating. The general CRC can be used for checking various data in addition to the code flash memory area. The data to be checked can be specified by using software (a user-created program).

The general CRC operation can be executed in the main system clock operation mode as well as the subsystem clock operation mode.

The CRC generator polynomial used is “ $X^{16} + X^{12} + X^5 + 1$ ” of CRC-16-CCITT. The data to be input is inverted in bit order and then calculated to allow for LSB-first communication. For example, if the data 12345678H is sent from the LSB, values are written to the CRCIN register in the order of 78H, 56H, 34H, and 12H, enabling a value of 08F6H to be obtained from the CRCD register. This is the result obtained by executing a CRC operation on the bit rows shown below, which consist of the data 12345678H inverted in bit order.

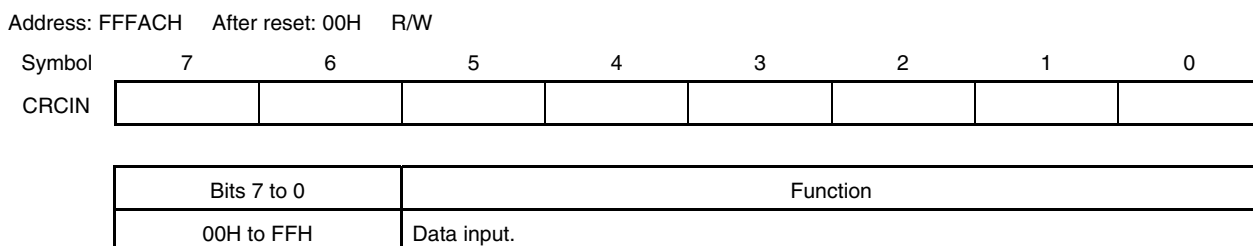


**<Control register>**

**(1) CRC input register (CRCIN)**

CRCIN register is an 8-bit register that is used to set the CRC operation data of general-purpose CRC. The possible setting range is 00H to FFH. The CRCIN register can be set by an 8-bit memory manipulation instruction. Reset signal generation clears this register to 00H.

**Figure 22-4. Format of CRC Input Register (CRCIN)**



**(2) CRC data register (CRCD)**

This register is used to store the CRC operation result of the general-purpose CRC.

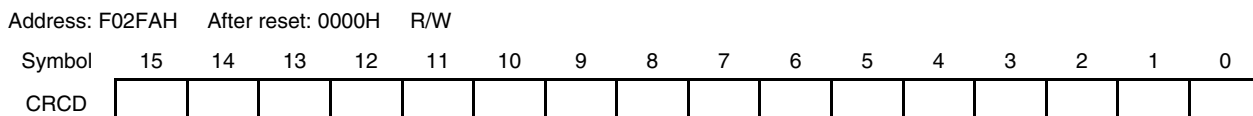
The setting range is 0000H to FFFFH.

After 1 clock of CPU/peripheral hardware clock ( $f_{CLK}$ ) has elapsed from the time CRCIN register is written, the CRC operation result is stored to the CRCD register.

The CRCD register can be set by a 16-bit memory manipulation instruction.

Reset signal generation clears this register to 0000H.

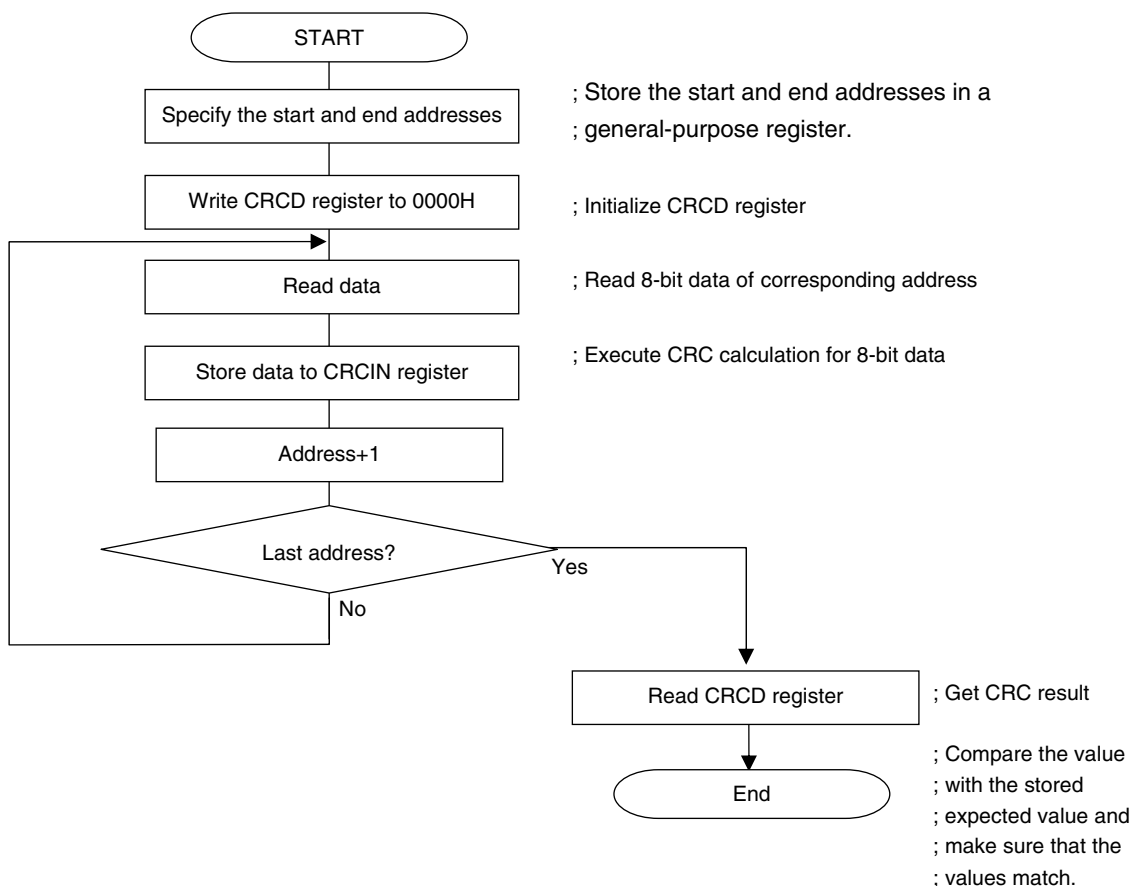
**Figure 22-5. Format of CRC Data Register (CRCD)**



- Cautions**
1. Read the value written to CRCD register before writing to CRCIN register.
  2. If conflict between writing and storing operation result to CRCD register occurs, the writing is ignored.

<Operation flow>

**Figure 22-6. CRC Operation Function (General-Purpose CRC)**



### 22.3.3 RAM parity error detection function

The IEC60730 standard mandates the checking of RAM data. A single-bit parity bit is therefore added to all 8-bit data in the RL78/G13's RAM. By using this RAM parity error detection function, the parity bit is appended when data is written, and the parity is checked when the data is read. This function can also be used to trigger a reset when a parity error occurs.

#### <Control register>

- **RAM parity error control register (RPECTL)**

This register is used to control parity error generation check bit and reset generation due to parity errors.

The RPECTL register can be set by a 1-bit or 8-bit memory manipulation instruction.

Reset signal generation clears this register to 00H.

**Figure 22-7. Format of RAM Parity Error Control Register (RPECTL)**

Address: F00F5H After reset: 00H R/W

Symbol	<7>	6	5	4	3	2	1	<0>
RPECTL	RPERDIS	0	0	0	0	0	0	RPEF
RPERDIS	Parity error reset mask flag							
0	Enable parity error resets.							
1	Disable parity error resets.							
RPEF	Parity error status flag							
0	No parity error has occurred.							
1	A parity error has occurred.							

**Caution** An instruction code fetched from RAM is not subject to parity error detection while it is being executed. However, the RL78's CPU executes lookahead due to the pipeline operation, the CPU might read an uninitialized RAM area that is allocated beyond the RAM used, which causes a RAM parity error. Therefore, when enabling RAM parity error resets (RPERDIS = 1), be sure to initialize the used RAM area + 10 bytes. When using the self-programming function while RAM parity error resets are enabled, be sure to initialize the RAM area to overwrite + 10 bytes before overwriting. The data read by the instruction is subject to parity error detection.

- Remarks**
1. The RAM parity check is always on, and the result can be confirmed by checking the RPEF flag.
  2. The parity error reset is enabled by default (RPERDIS = 0).  
Even if the parity error reset is disabled (RPERDIS = 1), the RPEF flag will be set (1) if a parity error occurs.
  3. The RPEF flag is set (1) by RAM parity errors and cleared (0) by writing 0 to it or by any reset source.  
When RPEF = 1, the value is retained even if RAM for which no parity error has occurred is read.



### 22.3.4 RAM guard function

In order to guarantee safety during operation, the IEC61508 standard mandates that important data stored in the RAM be protected, even if the CPU freezes.

This RAM guard function is used to protect data in the specified memory space.

If the RAM guard function is specified, writing to the specified RAM space is disabled, but reading from the space can be carried out as usual.

#### <Control register>

- **Invalid memory access detection control register (IAWCTL)**

This register is used to control the detection of invalid memory access and RAM/SFR guard function.

GRAM1 and GRAM0 bits are used in RAM guard function.

The IAWCTL register can be set by an 8-bit memory manipulation instruction.

Reset signal generation clears this register to 00H.

**Figure 22-8. Format of Invalid Memory Access Detection Control Register (IAWCTL)**

Address: F0078H After reset: 00H R/W

Symbol	7	6	5	4	3	2	1	0
IAWCTL	IAWEN	0	GRAM1	GRAM0	0	GPORT	GINT	GCSC

GRAM1	GRAM0	RAM guard space <sup>Note</sup>
0	0	Disabled. RAM can be written to.
0	1	The 128 bytes starting at the lower RAM address
1	0	The 256 bytes starting at the lower RAM address
1	1	The 512 bytes starting at the lower RAM address

**Note** The RAM start address differs depending on the size of the RAM provided with the product.

**22.3.5 SFR guard function**

In order to guarantee safety during operation, the IEC61508 standard mandates that important SFRs be protected from being overwritten, even if the CPU freezes.

This SFR guard function is used to protect data in the control registers used by the port function, interrupt function, clock control function, voltage detection function, and RAM parity error detection function.

If the SFR guard function is specified, writing to the specified SFRs is disabled, but reading from the SFRs can be carried out as usual.

**<Control register>**

• **Invalid memory access detection control register (IAWCTL)**

This register is used to control the detection of invalid memory access and RAM/SFR guard function.

GPORT, GINT and GCSC bits are used in SFR guard function.

The IAWCTL register can be set by an 8-bit memory manipulation instruction.

Reset signal generation clears this register to 00H.

**Figure 22-9. Format of Invalid Memory Access Detection Control Register (IAWCTL)**

Address: F0078H After reset: 00H R/W

Symbol	7	6	5	4	3	2	1	0
IAWCTL	IAWEN	0	GRAM1	GRAM0	0	GPORT	GINT	GCSC

GPORT	Control registers of port function guard
0	Disabled. Control registers of port function can be read or written to.
1	Enabled. Writing to control registers of port function is disabled. Reading is enabled. [Guarded SFR] PMxx, PUxx, PIMxx, POMxx, PMCxx, ADPC, PIOR <sup>Note 1</sup>

GINT	Registers of interrupt function guard
0	Disabled. Registers of interrupt function can be read or written to.
1	Enabled. Writing to registers of interrupt function is disabled. Reading is enabled. [Guarded SFR] IFxx, MKxx, PRxx, EGPx, EGNx

GCSC <sup>Notes 2</sup>	Control registers of clock control function, voltage detector and RAM parity error detection function guard
0	Disabled. Control registers of clock control function, voltage detector and RAM parity error detection function can be read or written to.
1	Enabled. Writing to control registers of clock control function, voltage detector and RAM parity error detection function is disabled. Reading is enabled. [Guarded SFR] CMC, CSC, OSTs, CKC, PERx, OSMC, LVIM, LVIS, RPECTL

- Notes**
1. Pxx (Port register) is not guarded.
  2. Clear GCSC bit to 0, during self programming /serial programming.

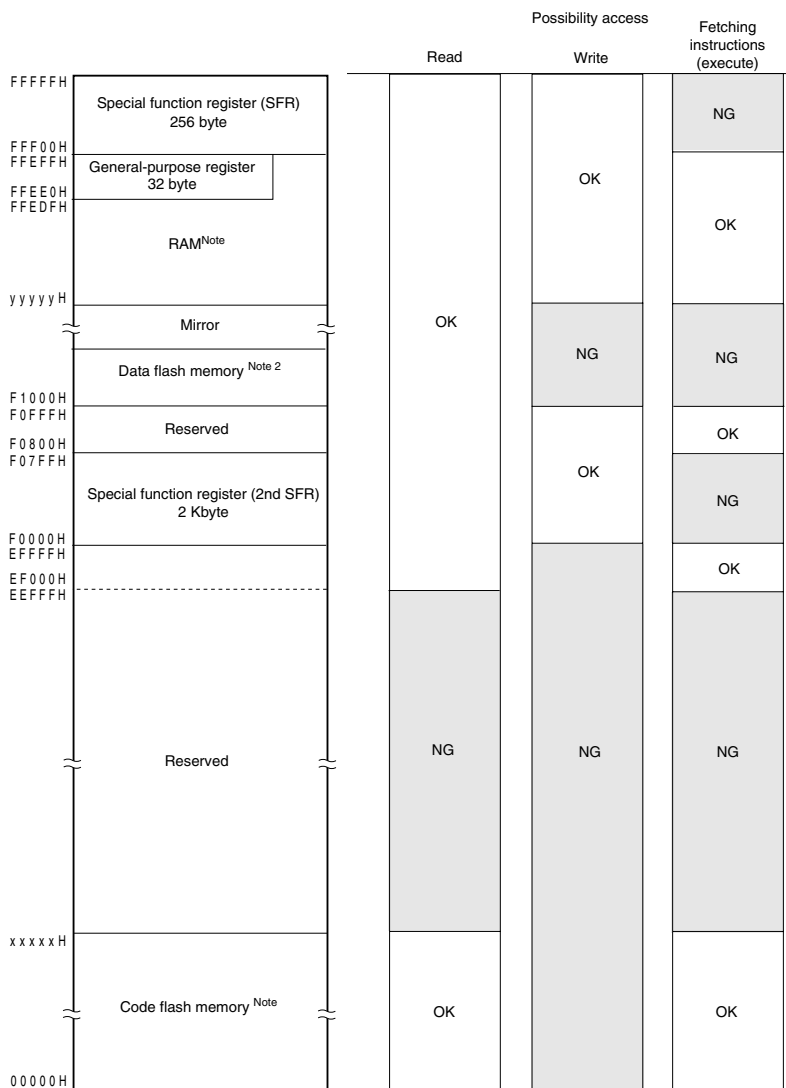
**22.3.6 Invalid memory access detection function**

The IEC60730 standard mandates checking that the CPU and interrupts are operating correctly.

The illegal memory access detection function triggers a reset if a memory space specified as access-prohibited is accessed.

The illegal memory access detection function applies to the areas indicated by NG in Figure 22-10.

**Figure 22-10. Invalid access detection area**



**Note** Code flash memory and RAM address of each product are as follows.

Products	Code flash memory (00000H to xxxxxH)	RAM (yyyyyH to FFEFFH)
R5F100xA, R5F101xA (x = 6 to 8, A to C, E to G)	16384 × 8 bit (00000H to 03FFFFH)	2048 × 8 bit (FF700H to FFEFFH)
R5F100xC, R5F101xC (x = 6 to 8, A to C, E to G, J, L)	32768 × 8 bit (00000H to 07FFFFH)	2048 × 8 bit (FF700H to FFEFFH)
R5F100xD, R5F101xD (x = 6 to 8, A to C, E to G, J, L)	49152 × 8 bit (00000H to 0BFFFFH)	3072 × 8 bit (FF300H to FFEFFH)
R5F100xE, R5F101xE (x = 6 to 8, A to C, E to G, J, L)	65536 × 8 bit (00000H to 0FFFFH)	4096 × 8 bit (FEE00H to FFEFFH)
R5F100xF, R5F101xF (x = A to C, E to G, J, L, M, P)	98304 × 8 bit (00000H to 17FFFFH)	8192 × 8 bit (FDF00H to FFEFFH)
R5F100xG, R5F101xG (x = A to C, E to G, J, L, M, P)	131072 × 8 bit (00000H to 1FFFFH)	12288 × 8 bit (FCF00H to FFEFFH)
R5F100xH, R5F101xH (x = E to G, J, L, M, P, S)	196608 × 8 bit (00000H to 2FFFFH)	16384 × 8 bit (FBF00H to FFEFFH)
R5F100xJ, R5F101xJ (x = F, G, J, L, M, P, S)	262144 × 8 bit (00000H to 3FFFFH)	20480 × 8 bit (FAF00H to FFEFFH)
R5F100xK, R5F101xK (x = F, G, J, L, M, P, S)	393216 × 8 bit (00000H to 5FFFFH)	24576 × 8 bit (F9F00H to FFEFFH)
R5F100xL, R5F101xL (x = F, G, J, L, M, P, S)	524288 × 8 bit (00000H to 7FFFFH)	32768 × 8 bit (F7F00H to FFEFFH)

<Control register>

• **Invalid memory access detection control register (IAWCTL)**

This register is used to control the detection of invalid memory access and RAM/SFR guard function.

IAWEN bit is used in invalid memory access detection function.

The IAWCTL register can be set by an 8-bit memory manipulation instruction.

Reset signal generation clears this register to 00H.

**Figure 22-11. Format of Invalid Memory Access Detection Control Register (IAWCTL)**

Address: F0078H After reset: 00H R/W

Symbol	7	6	5	4	3	2	1	0
IAWCTL	IAWEN	0	GRAM1	GRAM0	0	GPORT	GINT	GCSC

IAWEN <sup>Note</sup>	Control of invalid memory access detection
0	Disable the detection of invalid memory access.
1	Enable the detection of invalid memory access.

**Remark** By specifying WDTON = 1 for the option byte, the invalid memory access function is always enabled regardless of the setting for the IAWEN bit. (For details, see **CHAPTER 24 OPTION BYTE.**)

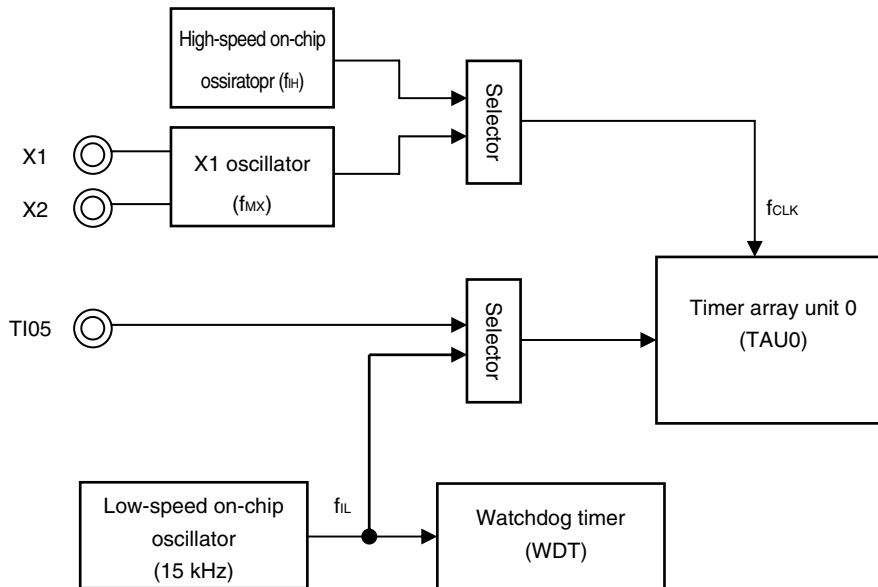
**Note** Only writing 1 to the IAWEN bit is enabled, not writing 0 to it after setting it to 1.

### 22.3.7 Frequency detection function

The IEC60730 standard mandates checking that the oscillation frequency is correct.

The frequency detection function can detect whether the clock is operating on an abnormal frequency by comparing the internal high-speed oscillation clock or external X1 oscillation clock with the internal low-speed oscillation clock (15 kHz).

**Figure 22-12. Configuration of Frequency Detection Function**



#### <Operational overview>

Whether the clock frequency is correct or not can be judged by measuring the pulse width under the following conditions:

- The internal high-speed oscillation clock ( $f_H$ ) or the external X1 oscillation clock ( $f_{MX}$ ) is selected as the CPU/peripheral hardware clock ( $f_{CLK}$ ).
- The internal low-speed oscillation clock ( $f_{IL}$ : 15 kHz) is selected as the timer input for channel 5 of timer array unit 0 (TAU0).

If pulse width measurement results in an abnormal value, it can be concluded that the clock frequency is abnormal. For how to execute pulse width measurement, see **6.7.4 Operation as input pulse interval measurement**.

## &lt;Control register&gt;

- **Timer input select register 0 (TIS0)**

This register is used to select the timer input of channel 5.

By selecting the internal low-speed oscillation clock for the timer input, its pulse width can be measured to determine whether the proportional relationship between the internal low-speed oscillation clock and the timer operation clock is correct.

The TIS0 register can be set by an 8-bit memory manipulation instruction.

Reset signal generation clears this register to 00H.

**Figure 22-13. Format of Timer Input Select Register 0 (TIS0)**

Address: F0074H    After reset: 00H    R/W

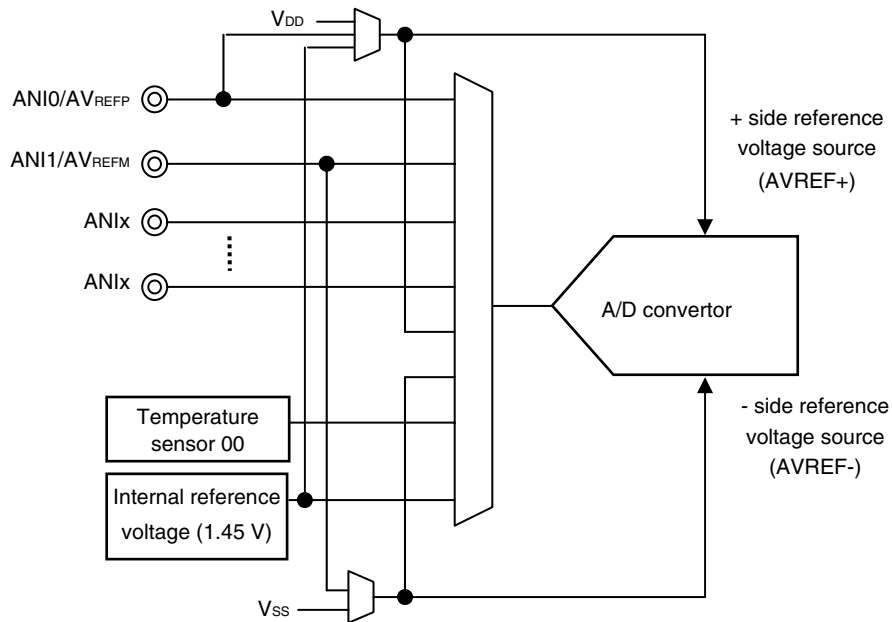
Symbol	7	6	5	4	3	2	1	0
TIS0	0	0	0	0	0	TIS02	TIS01	TIS00

TIS02	TIS01	TIS00	Selection of timer input used with channel 5
0	0	0	Input signal of timer input pin (TI05)
0	0	1	
0	1	0	
0	1	1	
1	0	0	Low-speed on-chip oscillator clock (f <sub>IL</sub> )
1	0	1	Subsystem clock (f <sub>SUB</sub> )
Other than the above			Setting prohibited

### 22.3.8 A/D test function

The IEC60730 standard mandates testing the A/D converter. The A/D test function is used to check whether the A/D converter is operating normally by executing A/D conversions of an internal voltage of 0 V, the AV<sub>REF</sub> voltage, and the internal reference voltage (1.45 V).

Figure 22-14. Configuration of A/D Test Function



## &lt;Control register&gt;

**(1) A/D test register (ADTES)**

This register is used to select the A/D converter's positive reference voltage  $AV_{REFP}$ , the A/D converter's negative reference voltage  $AV_{REFM}$ , or the analog input channel (ANlxx) as the target of A/D conversion.

When using the A/D test function, specify the following settings:

- Select  $AV_{REFM}$  as the target of A/D conversion when converting the internal 0 V.
- Select  $AV_{REFP}$  as the target of A/D conversion when converting  $AV_{REF}$ .
- Select ANlxx as the target of A/D conversion when converting the internal reference voltage (1.45 V), and specify the internal reference voltage output as the input source in the ADS register.

The ADTES register can be set by an 8-bit memory manipulation instruction.

Reset signal generation clears this register to 00H.

**Figure 22-15. Format of A/D Test Register (ADTES)**

Address: F0013H After reset: 00H R/W

Symbol	7	6	5	4	3	2	1	0
ADTES	0	0	0	0	0	0	ADTES1	ADTES0

ADTES1	ADTES0	A/D conversion target
0	0	ANlxx (This is specified using the analog input channel specification register (ADS).)
1	0	$AV_{REFM}$
1	1	$AV_{REFP}$
Other than the above		Setting prohibited



**(2) Analog input channel specification register (ADS)**

This register specifies the input channel of the analog voltage to be A/D converted.

Select ANI<sub>xx</sub> as the target of A/D conversion by ADTS register when converting the internal reference voltage (1.45 V), and specify the internal reference voltage output as the input source in the analog input channel specification register (ADS).

The ADS register can be set by a 1-bit or 8-bit memory manipulation instruction.

Reset signal generation clears this register to 00H.

**Figure 22-16. Format of Analog Input Channel Specification Register (ADS) (1/2)**

Address: FFF31H After reset: 00H R/W

Symbol	7	6	5	4	3	2	1	0
ADS	ADISS	0	0	ADS4	ADS3	ADS2	ADS1	ADS0

○ Select mode (ADMD = 0)

ADISS	ADS4	ADS3	ADS2	ADS1	ADS0	Analog input channel	Input source
0	0	0	0	0	0	ANI0	P20/ANI0/AV <sub>REFP</sub> pin
0	0	0	0	0	1	ANI1	P21/ANI1/AV <sub>REFM</sub> pin
0	0	0	0	1	0	ANI2	P22/ANI2 pin
0	0	0	0	1	1	ANI3	P23/ANI3 pin
0	0	0	1	0	0	ANI4	P24/ANI4 pin
0	0	0	1	0	1	ANI5	P25/ANI5 pin
0	0	0	1	1	0	ANI6	P26/ANI6 pin
0	0	0	1	1	1	ANI7	P27/ANI7 pin
0	0	1	0	0	0	ANI8	P150/ANI8 pin
0	0	1	0	0	1	ANI9	P151/ANI9 pin
0	0	1	0	1	0	ANI10	P152/ANI10 pin
0	0	1	0	1	1	ANI11	P153/ANI11 pin
0	0	1	1	0	0	ANI12	P154/ANI12 pin
0	0	1	1	0	1	ANI13	P155/ANI13 pin
0	0	1	1	1	0	ANI14	P156/ANI14 pin
0	0	1	1	1	1	Setting prohibited	
0	1	0	0	0	0	ANI16	P03/ANI16 pin <sup>Note 1</sup>
0	1	0	0	0	1	ANI17	P02/ANI17 pin <sup>Note 2</sup>
0	1	0	0	1	0	ANI18	P147/ANI18 pin
0	1	0	0	1	1	ANI19	P120/ANI19 pin
0	1	0	1	0	0	ANI20	P100/ANI20 pin
0	1	0	1	0	1	ANI21	P37/ANI21 pin
0	1	0	1	1	0	ANI22	P36/ANI22 pin
0	1	0	1	1	1	ANI23	P35/ANI23 pin
0	1	1	0	0	0	ANI24	P117/ANI24 pin
0	1	1	0	0	1	ANI25	P116/ANI25 pin
0	1	1	0	1	0	ANI26	P115/ANI26 pin
0	1	1	0	1	1	Setting prohibited	
1	0	0	0	0	0	–	Temperature sensor output
1	0	0	0	0	1	–	Internal reference voltage output (1.45 V)
Other than the above						Setting prohibited	

(Notes and cautions are listed on the next page.)

- Notes**
1. 20-, 24-, 25-, 30-, 32-pin products: P01/ANI16 pin
  2. 20-, 24-, 25-, 30-, 32-pin products: P00/ANI17 pin

- Cautions**
1. Be sure to clear bits 5 and 6 to 0.
  2. Only rewrite the value of the ADISS bit while A/D voltage comparator operation is stopped (which is indicated by the ADCS bit of A/D converter mode register 0 (ADM0) being 0).
  3. If using  $AV_{REFP}$  as the + side reference voltage source of the A/D converter, do not select ANI0 as an A/D conversion channel.
  4. If using  $AV_{REFM}$  as the – side reference voltage source of the A/D converter, do not select ANI1 as an A/D conversion channel.
  5. If ADISS is set to 1, the internal reference voltage (1.45 V) cannot be used for the + side reference

## CHAPTER 23 REGULATOR

## 23.1 Regulator Overview

The RL78/G13 contains a circuit for operating the device with a constant voltage. At this time, in order to stabilize the regulator output voltage, connect the REGC pin to V<sub>SS</sub> via a capacitor (0.47 to 1  $\mu$ F). Also, use a capacitor with good characteristics, since it is used to stabilize internal voltage.

<R> The regulator output voltage, see table 23-1.

<R> **Table 23-1. Regulator Output Voltage Conditions**

Mode	Output Voltage	Condition
Low voltage main mode	1.8 V	-
Low-speed main mode		
High-speed main mode	1.8 V	In STOP mode
		When both the high-speed system clock (f <sub>MX</sub> ) and the high-speed on-chip oscillator clock (f <sub>IH</sub> ) are stopped during CPU operation with the subsystem clock (f <sub>XT</sub> )
	When both the high-speed system clock (f <sub>MX</sub> ) and the high-speed on-chip oscillator clock (f <sub>IH</sub> ) are stopped during the HALT mode when the CPU operation with the subsystem clock (f <sub>XT</sub> ) has been set	
	2.1 V	Other than above (include during OCD mode) <sup>Note</sup>

**Note** When it shifts to the subsystem clock operation or STOP mode during the on-chip debugging, the regulator output voltage is kept at 2.1 V (not decline to 1.8 V).

## CHAPTER 24 OPTION BYTE

### 24.1 Functions of Option Bytes

Addresses 000C0H to 000C3H of the flash memory of the RL78/G13 form an option byte area.

Option bytes consist of user option byte (000C0H to 000C2H) and on-chip debug option byte (000C3H).

Upon power application or resetting and starting, an option byte is automatically referenced and a specified function is set. When using the product, be sure to set the following functions by using the option bytes.

To use the boot swap operation during self programming, 000C0H to 000C3H are replaced by 010C0H to 010C3H. Therefore, set the same values as 000C0H to 000C3H to 010C0H to 010C3H.

#### 24.1.1 User option byte (000C0H to 000C2H/010C0H to 010C2H)

##### (1) 000C0H/010C0H

- Operation of watchdog timer
  - Operation is stopped or enabled in the HALT or STOP mode.
- Setting of interval time of watchdog timer
- Operation of watchdog timer
  - Operation is stopped or enabled.
- Setting of window open period of watchdog timer
- Setting of interval interrupt of watchdog timer
  - Used or not used

**Caution** Set the same value as 000C0H to 010C0H when the boot swap operation is used because 000C0H is replaced by 010C0H.

##### (2) 000C1H/010C1H

- Setting of LVD operation mode
  - Interrupt & reset mode.
  - Reset mode.
- <R>  Interrupt mode.
- <R>  Setting of LVD detection level ( $V_{LVIH}$ ,  $V_{LVIL}$ ,  $V_{LVI}$ )

**Caution** Set the same value as 000C1H to 010C1H when the boot swap operation is used because 000C1H is replaced by 010C1H.

**(3) 000C2H/010C2H**

- Setting of flash operation mode
  - LV (low voltage main) mode
  - LS (low speed main) mode
  - HS (high speed main) mode
- Setting of the frequency of the high-speed on-chip oscillator
  - Select from 1 MHz, 4 MHz, 8 MHz, 12 MHz, 16 MHz, 24 MHz, and 32 MHz.

**Caution** Set the same value as 000C2H to 010C2H when the boot swap operation is used because 000C2H is replaced by 010C2H.

**24.1.2 On-chip debug option byte (000C3H/ 010C3H)**

- Control of on-chip debug operation
  - On-chip debug operation is disabled or enabled.
- Handling of data of flash memory in case of failure in on-chip debug security ID authentication
  - Data of flash memory is erased or not erased in case of failure in on-chip debug security ID authentication.

**Caution** Set the same value as 000C3H to 010C3H when the boot swap operation is used because 000C3H is replaced by 010C3H.

### 24.2 Format of User Option Byte

The format of user option byte is shown below.

**Figure 24-1. Format of User Option Byte (000C0H/010C0H)**

Address: 000C0H/010C0H<sup>Note 1</sup>

	7	6	5	4	3	2	1	0
	WDTINIT	WINDOW1	WINDOW0	WDTON	WDCS2	WDCS1	WDCS0	WDSTBYON

WDTINIT	Use of interval interrupt of watchdog timer		
0	Interval interrupt is not used.		
1	Interval interrupt is generated when 75% of the overflow time is reached.		

WINDOW1	WINDOW0	Watchdog timer window open period <sup>Note 2</sup>	
0	0	Setting prohibited	
0	1	50%	
1	0	75%	
1	1	100%	

WDTON	Operation control of watchdog timer counter		
0	Counter operation disabled (counting stopped after reset)		
1	Counter operation enabled (counting started after reset)		

WDCS2	WDCS1	WDCS0	Watchdog timer overflow time (f <sub>IL</sub> = 17.25 kHz (MAX.))	
0	0	0	2 <sup>6</sup> /f <sub>IL</sub> (3.71 ms)	
0	0	1	2 <sup>7</sup> /f <sub>IL</sub> (7.42 ms)	
0	1	0	2 <sup>8</sup> /f <sub>IL</sub> (14.84 ms)	
0	1	1	2 <sup>9</sup> /f <sub>IL</sub> (29.68 ms)	
1	0	0	2 <sup>11</sup> /f <sub>IL</sub> (118.72 ms)	
1	0	1	2 <sup>13</sup> /f <sub>IL</sub> (474.90 ms)	
1	1	0	2 <sup>14</sup> /f <sub>IL</sub> (949.80 ms)	
1	1	1	2 <sup>16</sup> /f <sub>IL</sub> (3799.19m s)	

WDSTBYON	Operation control of watchdog timer counter (HALT/STOP mode)		
0	Counter operation stopped in HALT/STOP mode <sup>Note 2</sup>		
1	Counter operation enabled in HALT/STOP mode		

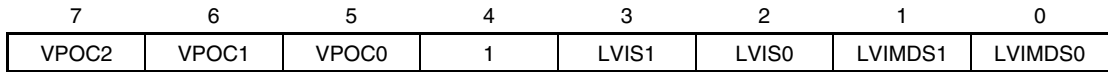
- Notes**
1. Set the same value as 000C0H to 010C0H when the boot swap operation is used because 000C0H is replaced by 010C0H.
  2. The window open period is 100% when WDSTBYON = 0, regardless the value of the WINDOW1 and WINDOW0 bits.

<R> **Caution** The watchdog timer continues its operation during EEPROM emulation. During processing, the interrupt acknowledge time is delayed. Set the overflow time and window size taking this delay into consideration.

**Remark** f<sub>IL</sub>: Low-speed on-chip oscillator clock frequency

Figure 24-2. Format of User Option Byte (000C1H/010C1H) (1/2)

Address: 000C1H/010C1H<sup>Note</sup>



- When used as interrupt & reset mode

Detection voltage			Option byte Setting Value												
V <sub>LVIH</sub>		V <sub>LVIL</sub>	LVIMDS1	LVIMDS0	VPOC2	VPOC1	VPOC0	LVIS1	LVIS0						
Rising edge	Falling edge	Falling edge													
1.77 V	1.73 V	1.63 V	1	0	0	0	0	1	0						
1.88 V	1.84 V							0	1						
2.92 V	2.86 V							0	0						
1.98 V	1.94 V	1.84 V			1	0	0	0	1	1	0				
2.09 V	2.04 V									0	1				
3.13 V	3.06 V									0	0				
2.61 V	2.55 V	2.45 V					1	0	0	1	0	1	0		
2.71 V	2.65 V											0	1		
3.75 V	3.67 V											0	0		
2.92 V	2.86 V	2.75 V							1	0	0	1	1	1	0
3.02 V	2.96 V													0	1
4.06 V	3.98 V													0	0
Other than above			Setting prohibited												

<R>

- When used as reset mode

Detection voltage		Option byte Setting Value								
V <sub>LVI</sub>		LVIMDS1	LVIMDS0	VPOC2	VPOC1	VPOC0	LVIS1	LVIS0		
Rising edge	Falling edge									
1.67 V	1.63 V	1	1	0	0	0	1	1		
1.77 V	1.73 V			0	0	0	1	0		
1.88 V	1.84 V			0	0	1	1	1		
1.98 V	1.94 V			0	0	1	1	0		
2.09 V	2.04 V			0	0	1	0	1		
2.50 V	2.45 V			0	1	0	1	1		
2.61 V	2.55 V			0	1	0	1	0		
2.71 V	2.65 V			0	1	0	0	1		
2.81 V	2.75 V			0	1	1	1	1		
2.92 V	2.86 V			0	1	1	1	0		
3.02 V	2.96 V			0	1	1	0	1		
3.13 V	3.06 V			0	0	1	0	0		
3.75 V	3.67 V			0	1	0	0	0		
4.06 V	3.98 V			0	1	1	0	0		
Other than above				Setting prohibited						

**Note** Set the same value as 000C1H to 010C1H when the boot swap operation is used because 000C1H is replaced by 010C1H.

**Caution** Be sure to set bit 4 to “1”.

Figure 24-2. Format of User Option Byte (000C1H/010C1H) (2/2)

Address: 000C1H/010C1H<sup>Note</sup>

7	6	5	4	3	2	1	0
VPOC2	VPOC1	VPOC0	1	LVIS1	LVIS0	LVIMDS1	LVIMDS0

<R> • When used as interrupt mode

Detection voltage		Option byte Setting Value						
V <sub>LVI</sub>		LVIMDS1	LVIMDS0	VPOC2	VPOC1	VPOC0	LVIS1	LVIS0
Rising edge	Falling edge							
1.67 V	1.63 V	0	1	0	0	0	1	1
1.77 V	1.73 V			0	0	0	1	0
1.88 V	1.84 V			0	0	1	1	1
1.98 V	1.94 V			0	0	1	1	0
2.09 V	2.04 V			0	0	1	0	1
2.50 V	2.45 V			0	1	0	1	1
2.61 V	2.55 V			0	1	0	1	0
2.71 V	2.65 V			0	1	0	0	1
2.81 V	2.75 V			0	1	1	1	1
2.92 V	2.86 V			0	1	1	1	0
3.02 V	2.96 V			0	1	1	0	1
3.13 V	3.06 V			0	0	1	0	0
3.75 V	3.67 V			0	1	0	0	0
4.06 V	3.98 V			0	1	1	0	0
Other than above				Setting prohibited				

<R> • When LVDOFF

Detection voltage		Option byte Setting Value						
V <sub>LVI</sub>		LVIMDS1	LVIMDS0	VPOC2	VPOC1	VPOC0	LVIS1	LVIS0
Rising edge	Falling edge							
-	-	0/1	1	1	×	×	×	×
Other than above		Setting prohibited						

**Note** Set the same value as 000C1H to 010C1H when the boot swap operation is used because 000C1H is replaced by 010C1H.

**Caution** Be sure to set bit 4 to “1”.

**Remark** ×: don't care



Figure 24-3. Format of Option Byte (000C2H/010C2H)

Address: 000C2H/010C2H<sup>Note</sup>

7	6	5	4	3	2	1	0
CMODE1	CMODE0	1	0	FRQSEL3	FRQSEL2	FRQSEL1	FRQSEL0

&lt;R&gt;

CMODE1	CMODE0	Setting of flash operation mode		
			Operating Frequency Range	Operating Voltage Range
0	0	LV (low voltage main) mode	1 to 4 MHz	1.6 to 5.5 V
1	0	LS (low speed main) mode	1 to 8 MHz	1.8 to 5.5 V
1	1	HS (high speed main) mode	1 to 16 MHz	2.4 to 5.5 V
			1 to 32 MHz	2.7 to 5.5 V
Other than above		Setting prohibited		

FRQSEL3	FRQSEL2	FRQSEL1	FRQSEL0	Frequency of the high-speed on-chip oscillator
1	0	0	0	32 MHz
0	0	0	0	24 MHz
1	0	0	1	16 MHz
0	0	0	1	12 MHz
1	0	1	0	8 MHz
1	0	1	1	4 MHz
1	1	0	1	1 MHz
Other than above				Setting prohibited

**Note** Set the same value as 000C2H to 010C2H when the boot swap operation is used because 000C2H is replaced by 010C2H.

### 24.3 Format of On-chip Debug Option Byte

The format of on-chip debug option byte is shown below.

**Figure 24-4. Format of On-chip Debug Option Byte (000C3H/010C3H)**

Address: 000C3H/010C3H<sup>Note</sup>

7	6	5	4	3	2	1	0
OCDENSET	0	0	0	0	1	0	OCDERSD

OCDENSET	OCDERSD	Control of on-chip debug operation
0	0	Disables on-chip debug operation.
0	1	Setting prohibited
1	0	Enables on-chip debugging. Erases data of flash memory in case of failures in authenticating on-chip debug security ID.
1	1	Enables on-chip debugging. Does not erases data of flash memory in case of failures in authenticating on-chip debug security ID.

**Note** Set the same value as 000C3H to 010C3H when the boot swap operation is used because 000C3H is replaced by 010C3H.

**Caution** Bits 7 and 0 (OCDENSET and OCDERSD) can only be specified a value.  
Be sure to set 000010B to bits 6 to 1.

**Remark** The value on bits 3 to 1 will be written over when the on-chip debug function is in use and thus it will become unstable after the setting.  
However, be sure to set the default values (0, 1, and 0) to bits 3 to 1 at setting.

## 24.4 Setting of Option Byte

The user option byte and on-chip debug option byte can be set using the assembler linker option, in addition to describing to the source. When doing so, the contents set by using the linker option take precedence, even if descriptions exist in the source, as mentioned below.

A software description example of the option byte setting is shown below.

OPT	CSEG	OPT_BYTE	
	DB	36H	; Does not use interval interrupt of watchdog timer, ; Enables watchdog timer operation, ; Window open period of watchdog timer is 50%, ; Overflow time of watchdog timer is $2^9/f_{IL}$ , ; Stops watchdog timer operation during HALT/STOP mode
	DB	1AH	; Select 1.63 V for $V_{LVIL}$ ; Select rising edge 1.77 V, falling edge 1.73 V for $V_{LVIH}$ ; Select the interrupt & reset mode as the LVD operation mode
	DB	2DH	; Select the LV (low voltage main) mode as the flash operation mode and 1 MHz as the frequency of the high-speed on-chip oscillator
	DB	85H	; Enables on-chip debug operation, does not erase flash memory data when security ID authorization fails

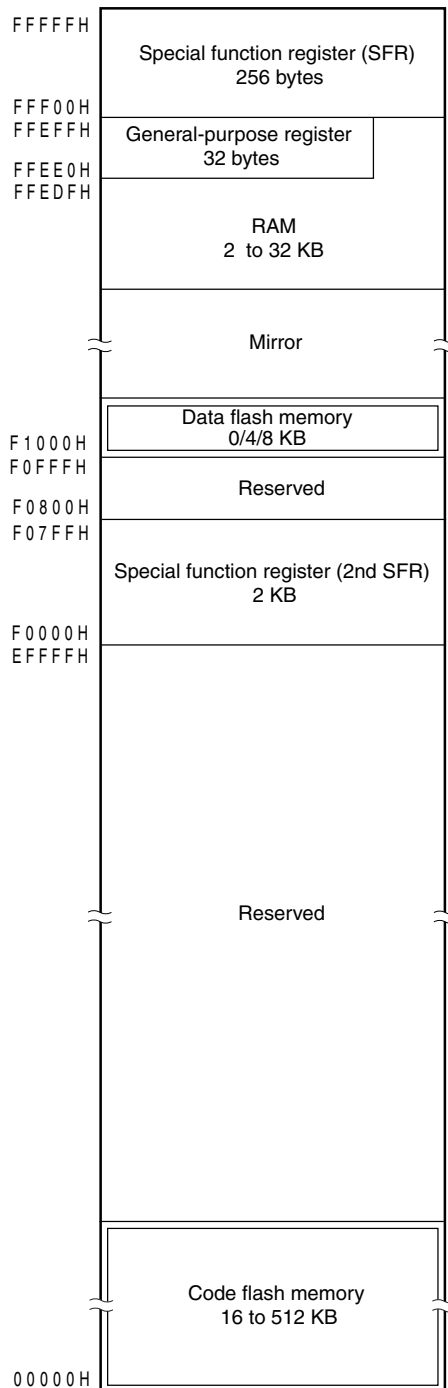
When the boot swap function is used during self programming, 000C0H to 000C3H is switched to 010C0H to 010C3H. Describe to 010C0H to 010C3H, therefore, the same values as 000C0H to 000C3H as follows.

OPT2	CSEG	AT	010C0H	
	DB		36H	; Does not use interval interrupt of watchdog timer, ; Enables watchdog timer operation, ; Window open period of watchdog timer is 50%, ; Overflow time of watchdog timer is $2^{10}/f_{IL}$ , ; Stops watchdog timer operation during HALT/STOP mode
	DB		1AH	; Select 1.63 V for $V_{LVIL}$ ; Select rising edge 1.77 V, falling edge 1.73 V for $V_{LVIH}$ ; Select the interrupt & reset mode as the LVD operation mode
	DB		2DH	; Select the LV (low main voltage) mode as the flash operation mode and 1 MHz as the frequency of the high-speed on-chip oscillator
	DB		85H	; Enables on-chip debug operation, does not erase flash memory data when security ID authorization fails

**Caution** To specify the option byte by using assembly language, use `OPT_BYTE` as the relocation attribute name of the `CSEG` pseudo instruction. To specify the option byte to 010C0H to 010C3H in order to use the boot swap function, use the relocation attribute `AT` to specify an absolute address.

**CHAPTER 25 FLASH MEMORY**

The RL78/G13 incorporates the flash memory to which a program can be written, erased, and overwritten while mounted on the board. The flash memory includes the “code flash memory”, in which programs can be executed, and the “data flash memory”, an area for storing data.



The following three methods for programming the flash memory are available:

- Writing to flash memory by using flash memory programmer (see 25.1)
- Writing to flash memory by using external device (that Incorporates UART) (see 25.2)
- Self-programming (see 25.7)

## 25.1 Writing to Flash Memory by Using Flash Memory Programmer

The following dedicated flash memory programmer can be used to write data to the internal flash memory of the RL78/G13.

- PG-FP5, FL-PR5
- E1 on-chip debugging emulator

Data can be written to the flash memory on-board or off-board, by using a dedicated flash memory programmer.

### (1) On-board programming

The contents of the flash memory can be rewritten after the RL78/G13 has been mounted on the target system. The connectors that connect the dedicated flash memory programmer must be mounted on the target system.

### (2) Off-board programming

Data can be written to the flash memory with a dedicated program adapter (FA series) before the RL78/G13 is mounted on the target system.

**Remark** FL-PR5 and FA series are products of Naito Densetsu Machida Mfg. Co., Ltd.

<R> **Table 25-1. Wiring Between RL78/G13 and Dedicated Flash Memory Programmer**

Pin Configuration of Dedicated Flash Memory Programmer				Pin Name	Pin No.								
Signal Name		I/O	Pin Function		20-pin	24-pin	25-pin	30-pin	32-pin	36-pin	40-pin	44-pin	
PG-FP5, FL-PR5	E1 on-chip debugging emulator				SSOP	WQFN (4x4)	FLGA (3x3)	SSOP	WQFN (5x5)	FLGA (4x4)	WQFN (6x6)	LQFP (10x10)	
-	TOOL0	I/O	Transmit/receive signal	TOOL0/P40	3	23	A5	5	1	6F	1	2	
SI/RxD	-	I/O	Transmit/receive signal										
SCK	-	Output	-	-	-	-	-	-	-	-	-	-	
CLK	-	Output	-	-	-	-	-	-	-	-	-	-	
-	RESET	Output	Reset signal	RESET	4	24	B5	6	2	5E	2	3	
/RESET	-	Output											
FLMD0	-	Output	Mode signal	-	-	-	-	-	-	-	-	-	
V <sub>DD</sub>		I/O	V <sub>DD</sub> voltage generation/power monitoring	V <sub>DD</sub>	10	6	B3	12	8	6B	10	11	
GND		-	Ground	V <sub>SS</sub>	9	5	B2	11	7	5C	9	10	
				EV <sub>SS</sub>	-	-	-	-	-	-	-	-	-
				REGC <sup>Note</sup>	8	4	A2	10	6	5D	8	9	
EMV <sub>DD</sub>		-	Driving power for TOOL pin	V <sub>DD</sub>	10	6	B3	12	8	6B	10	11	

Pin Configuration of Dedicated Flash Memory Programmer				Pin Name	Pin No.							
Signal Name		I/O	Pin Function		48-pin	52-pin	64-pin		80-pin	100-pin		128-pin
PG-FP5, FL-PR5	E1 on-chip debugging emulator				LQFP (7x7), WQFN (7x7)	LQFP (10x10)	LQFP (12x12), LQFP (10x10), TQFP (7x7)	FBGA (4x4)	LQFP (14x14), LQFP (12x12)	LQFP (14x14)	LQFP (14x20)	LQFP (14x20)
-	TOOL0	I/O	Transmit/receive signal	TOOL0/P40	39	4	5	D6	9	12	89	22
SI/RxD	-	I/O	Transmit/receive signal									
SCK	-	Output	-	-	-	-	-	-	-	-	-	-
CLK	-	Output	-	-	-	-	-	-	-	-	-	-
-	RESET	Output	Reset signal	RESET	40	5	6	E7	10	13	90	26
/RESET	-	Output										
FLMD0	-	Output	Mode signal	-	-	-	-	-	-	-	-	-
V <sub>DD</sub>		I/O	V <sub>DD</sub> voltage generation/power monitoring	V <sub>DD</sub>	48	13	15	B7	19	22	99	35
GND		-	Ground	V <sub>SS</sub>	47	12	13	C7	17	20	97	33
				EV <sub>SS</sub>	-	-	14	B8	18	21, 43	98, 20	34, 56
				REGC <sup>Note</sup>	46	11	12	D7	16	19	96	32
EMV <sub>DD</sub>		-	Driving power for TOOL pin	V <sub>DD</sub>	48	13	-	-	-	-	-	-
				EV <sub>DD</sub>	-	-	16	A8	20	23, 53	100, 30	36, 57

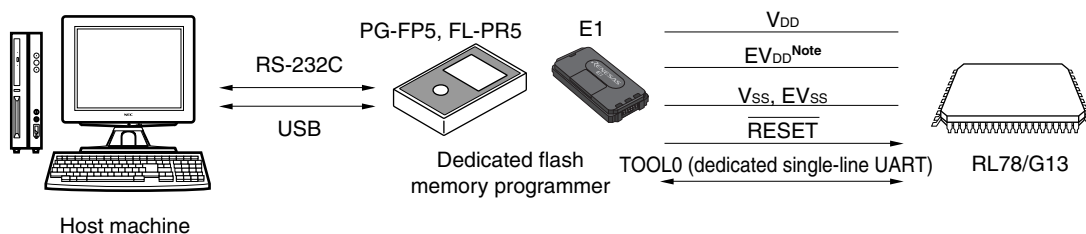
**Note** Connect REGC pin to ground via a capacitor (default: 0.47 μF).

**Remark** Pins that are not indicated in the above table can be left open when using the flash memory programmer for flash programming.

25.1.1 Programming Environment

The environment required for writing a program to the flash memory of the RL78/G13 is illustrated below.

Figure 25-1. Environment for Writing Program to Flash Memory



**Note** 64-pin, 80-pin, 100-pin and 128-pin products only.

A host machine that controls the dedicated flash memory programmer is necessary.

To interface between the dedicated flash memory programmer and the RL78/G13, the TOOL0 pin is used for manipulation such as writing and erasing via a dedicated single-line UART. To write the flash memory off-board, a dedicated program adapter (FA series) is necessary.

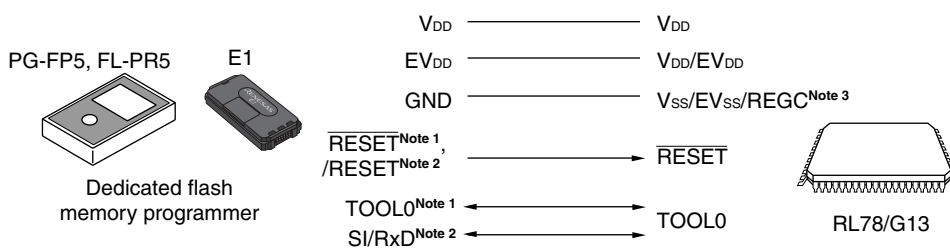
25.1.2 Communication Mode

Communication between the dedicated flash memory programmer and the RL78/G13 is established by serial communication using the TOOL0 pin via a dedicated single-line UART of the RL78/G13.

Transfer rate: 1 M, 500 k, 250 k, 115.2 kbps

<R>

Figure 25-2. Communication with Dedicated Flash Memory Programmer



- Notes**
1. When using E1 on-chip debugging emulator.
  2. When using PG-FP5 or FL-PR5.
  3. Connect REGC pin to ground via a capacitor (default: 0.47  $\mu$ F).

The dedicated flash memory programmer generates the following signals for the RL78/G13. See the manual of PG-FP5, FL-PR5, or E1 on-chip debugging emulator for details.

**Table 25-2. Pin Connection**

Dedicated Flash Memory Programmer			RL78/G13	Connection	
Signal Name		I/O	Pin Name		
PG-FP5, FL-PR5	E1 on-chip debugging emulator				
FLMD0	–	Output	Mode signal	–	×
V <sub>DD</sub>		I/O	V <sub>DD</sub> voltage generation/power monitoring	V <sub>DD</sub>	◎
GND		–	Ground	V <sub>SS</sub> , EV <sub>SS</sub> , REGC <sup>Note</sup>	◎
EMV <sub>DD</sub>		–	Driving power for TOOL pin	V <sub>DD</sub> , EV <sub>DD</sub>	◎
CLK	–	Output	Clock output	–	×
/RESET	–	Output	Reset signal	$\overline{\text{RESET}}$	◎
–	$\overline{\text{RESET}}$	Output			
–	TOOL0	I/O	Transmit/receive signal	TOOL0	◎
SI/RxD	–	I/O	Transmit/receive signal		
SCK	–	Output	Transfer clock	–	×

**Note** Connect REGC pin to ground via a capacitor (default: 0.47  $\mu$ F).

**Remark** ◎: Be sure to connect the pin.  
 ×: The pin does not have to be connected.

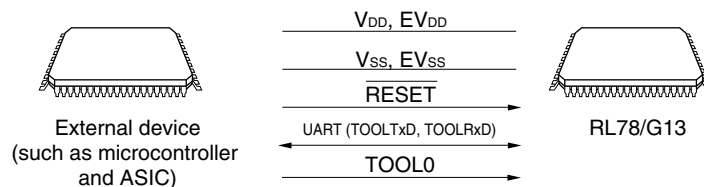
### 25.2 Writing to Flash Memory by Using External Device (that Incorporates UART)

On-board data writing to the internal flash memory is possible by using the RL78/G13 and an external device (a microcontroller or ASIC) connected to a UART.

#### 25.2.1 Programming Environment

The environment required for writing a program to the flash memory of the RL78/G13 is illustrated below.

**Figure 25-3. Environment for Writing Program to Flash Memory**



Processing to write data to or delete data from the RL78/G13 by using an external device is performed on-board. Off-board writing is not possible.

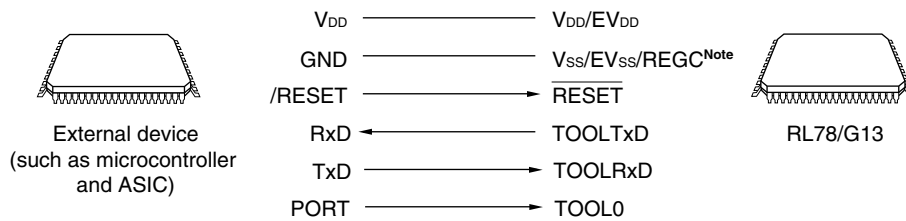


**25.2.2 Communication Mode**

Communication between the external device and the RL78/G13 is established by serial communication using the <R> TOOLTxD and TOOLRxD pins via the dedicated UART of the RL78/G13.

<R> Transfer rate: 1 M, 500 k, 250 k, 115.2kbps

**Figure 25-4. Communication with External Device**



**Note** Connect REGC pin to ground via a capacitor (default: 0.47  $\mu$ F).

**Caution** Make EV<sub>DD</sub> the same potential as V<sub>DD</sub>.

The external device generates the following signals for the RL78/G13.

**Table 25-3. Pin Connection**

External Device			RL78/G13	Connection
Signal Name	I/O	Pin Function	Pin Name	
V <sub>DD</sub>	I/O	V <sub>DD</sub> voltage generation/power monitoring	V <sub>DD</sub> , EV <sub>DD</sub>	◎
GND	–	Ground	V <sub>SS</sub> , EV <sub>SS</sub> , REGC <sup>Note</sup>	◎
CLK	Output	Clock output	–	×
RESETOUT	Output	Reset signal output	RESET	◎
RxD	Input	Receive signal	TOOL0TxD	◎
TxD	Output	Transmit signal	TOOL0RxD	◎
PORT	Output	Mode signal	TOOL0	◎
SCK	Output	Transfer clock	–	×

**Note** Connect REGC pin to ground via a capacitor (default: 0.47  $\mu$ F).

**Caution** Make EV<sub>DD</sub> the same potential as V<sub>DD</sub>.

**Remark** ◎: Be sure to connect the pin.  
 ×: The pin does not have to be connected.

## 25.3 Connection of Pins on Board

To write the flash memory on-board by using the flash memory programmer, connectors that connect the dedicated flash memory programmer must be provided on the target system. First provide a function that selects the normal operation mode or flash memory programming mode on the board.

When the flash memory programming mode is set, all the pins not used for programming the flash memory are in the same status as immediately after reset. Therefore, if the external device does not recognize the state immediately after reset, the pins must be handled as described below.

### 25.3.1 P40/TOOL0 pin

In the flash memory programming mode, connect this pin to the dedicated flash memory programmer via an external 1 k $\Omega$  pull-up resistor.

When this pin is used as the port pin, use that by the following method.

When used as an input pin: Input of low-level is prohibited for 1 ms period after pin reset release. Furthermore, when this pin is used via pull-down resistors, use the 500 k $\Omega$  or more resistors.

When used as an output pin: When this pin is used via pull-down resistors, use the 500 k $\Omega$  or more resistors.

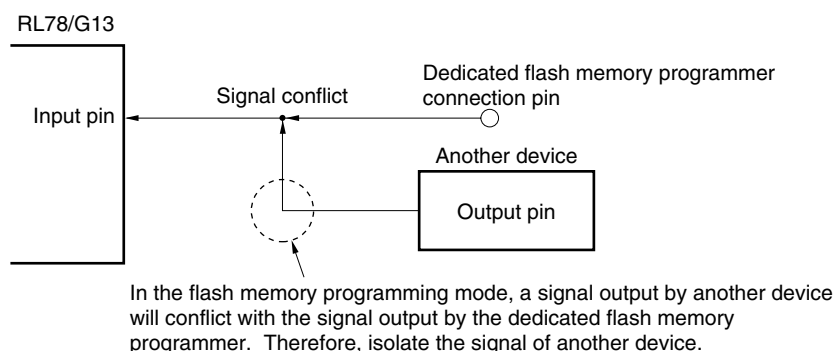
**Remark** The SAU and IICA pins are not used for communication between the RL78/G13 and dedicated flash memory programmer, because single-line UART (TOOL0 pin) is used.

### 25.3.2 $\overline{\text{RESET}}$ pin

Signal conflict will occur if the reset signal of the dedicated flash memory programmer and external device are connected to the  $\overline{\text{RESET}}$  pin that is connected to the reset signal generator on the board. To prevent this conflict, isolate the connection with the reset signal generator.

The flash memory will not be correctly programmed if the reset signal is input from the user system while the flash memory programming mode is set. Do not input any signal other than the reset signal of the dedicated flash memory programmer and external device.

**Figure 25-5. Signal Conflict ( $\overline{\text{RESET}}$  Pin)**



### 25.3.3 Port pins

When the flash memory programming mode is set, all the pins not used for flash memory programming enter the same status as that immediately after reset. If external devices connected to the ports do not recognize the port status immediately after reset, the port pin must be connected to either to  $V_{DD}$  or  $EV_{DD}$ , or  $V_{SS}$  or  $EV_{SS}$ , via a resistor.

### 25.3.4 REGC pin

Connect the REGC pin to GND via a capacitor (0.47 to 1  $\mu$ F) in the same manner as during normal operation. Also, use a capacitor with good characteristics, since it is used to stabilize internal voltage.

### 25.3.5 X1 and X2 pins

Connect X1 and X2 in the same status as in the normal operation mode.

**Remark** In the flash memory programming mode, the high-speed on-chip oscillator clock ( $f_{IH}$ ) is used.

### 25.3.6 Power supply

To use the supply voltage output of the flash memory programmer, connect the  $V_{DD}$  pin to  $V_{DD}$  of the flash memory programmer, and the  $V_{SS}$  pin to GND of the flash memory programmer.

To use the on-board supply voltage, connect in compliance with the normal operation mode.

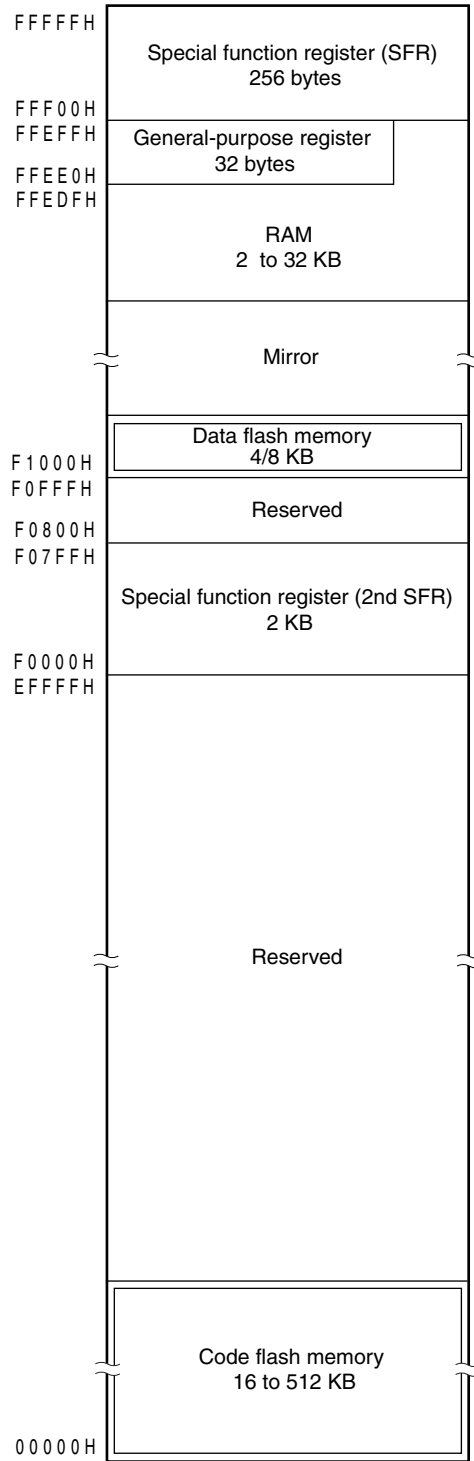
However, when writing to the flash memory by using the flash memory programmer and using the on-board supply voltage, be sure to connect the  $V_{DD}$  and  $V_{SS}$  pins to  $V_{DD}$  and GND of the flash memory programmer to use the power monitor function with the flash memory programmer.

Supply the same other power supplies ( $EV_{DD}$ ,  $EV_{SS}$ ) as those  $V_{DD}$  and  $V_{SS}$ .

## 25.4 Data Flash

### 25.4.1 Data flash overview

<R> In addition to 16 to 512 KB of code flash memory, the RL78/G13 with data flash includes 4/8 KB of data flash memory for storing data.



An overview of the data flash memory is provided below.

- The data flash memory can be written to by using the flash memory programmer or an external device
- <R> • Programming is performed in 8-bit units
- Blocks can be deleted in 1 KB units
- The only access by CPU instructions is byte reading (reading: four clock cycles)
- Because the data flash memory is an area exclusively used for data, it cannot be used to execute instructions (code fetching)
- Instructions can be executed from the code flash memory while rewriting the data flash memory (That is, back ground operation (BGO) is supported)
- Accessing the data flash memory is not possible while rewriting the code flash memory (during self programming)
- Because the data flash memory is stopped after a reset ends, the data flash control register (DFLCTL) must be set up in order to use the data flash memory
- Manipulating the DFLCTL register is not possible while rewriting the data flash memory
- <R> • When data flash is accessed, the CPU waits for three clock cycles

### 25.4.2 Register controlling data flash memory

#### (1) Data flash control register (DFLCTL)

This register is used to enable or disable accessing to the data flash.

The DFLCTL register is set by a 1-bit or 8-bit memory manipulation instruction.

Reset input sets this register to 00H.

**Figure 25-6. Format of Data Flash Control Register (DFLCTL)**

Address: F0090H    After reset: 00H    R/W

Symbol	7	6	5	4	3	2	1	<input type="checkbox"/>
DFLCTL	0	0	0	0	0	0	0	DFLEN

DFLEN	Data flash access control
0	Disables data flash access
1	Enables data flash access

**Caution** Manipulating the DFLCTL register is not possible while rewriting the data flash memory.

### 25.4.3 Procedure for accessing data flash memory

The data flash memory is initially stopped after a reset ends and cannot be accessed (read or programmed). To access the memory, perform the following procedure:

<1> Write 1 to bit 0 (DFLEN) of the data flash control register (DFLCTL).

<2> Wait for the setup to finish.

The time setup takes differs for each main clock mode.

<Setup time for each main clock mode>

- <R>
- HS (High-speed main): 5  $\mu$ s
  - LS (Low-speed main): 720 ns
  - LV (Low-voltage main): 10  $\mu$ s

<3> After the wait, the data flash memory can be accessed.

**Cautions 1. Accessing the data flash memory is not possible during the setup time.**

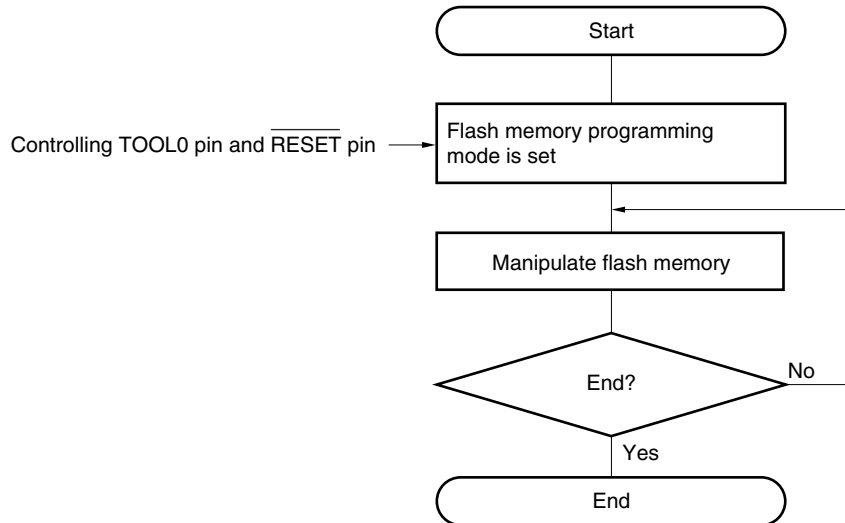
**2. Before executing a STOP instruction during the setup time, temporarily clear DFLEN to 0.**

## 25.5 Programming Method

### 25.5.1 Controlling flash memory

The following figure illustrates the procedure to manipulate the flash memory.

**Figure 25-7. Flash Memory Manipulation Procedure**



**25.5.2 Flash memory programming mode**

To rewrite the contents of the flash memory, set the RL78/G13 in the flash memory programming mode. To enter the mode, set as follows.

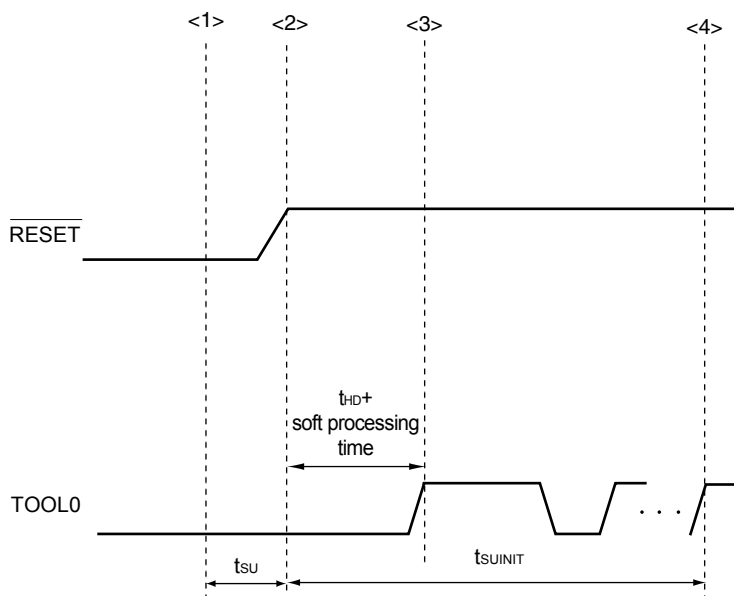
<When programming by using the dedicated flash memory programmer>

<R> Communication from the dedicated flash memory programmer is performed to automatically switch to the flash memory programming mode.

<When programming by using an external device>

<R> Set the TOOL0 pin to the low level, and then cancel the reset. Keep the TOOL0 pin at the low level from the reset ends to 1 ms + software processing end, and then use UART communication to send the data “00H” from the external device. Finish UART communication within 100 ms after the reset ends.

**Figure 25-8. Setting of Flash Memory Programming Mode**



- <1> The low level is input to the TOOL0 pin.
- <2> The pins reset ends (POR and LVD reset must end before the pin reset ends.).
- <3> The TOOL0 pin is set to the high level.
- <4> Setting of the flash memory programming mode by UART reception and complete the baud rate setting.

**Remark**  $t_{SUIINIT}$ : The segment shows that it is necessary to finish specifying the initial communication settings within 100 ms from when the external and internal resets end.

- $t_{SU}$ : How long from when the TOOL0 pin is placed at the low level until a pin reset ends
- $t_{HD}$ : How long to keep the TOOL0 pin at the low level from when the external and internal resets end



**Table 25-4. Relationship Between TOOL0 Pin and Operation Mode After Reset Release**

TOOL0	Operation Mode
V <sub>DD</sub>	Normal operation mode
0	Flash memory programming mode

There are two flash memory programming modes for which the voltage range in which to write, erase, or verify data differs.

**Table 25-5. Programming Modes and Voltages at Which Data Can Be Written, Erased, or Verified**

Mode	Voltages at which data can be written, erased, or verified
Wide voltage mode	1.8 V to 5.5 V
Full speed mode <sup>Note</sup>	2.4 V to 5.5 V
	2.7 V to 5.5 V

**Note** This can only be specified if the CMODE1 and CMODE0 bits of the option byte 000C2H are 1.

Specify the mode that corresponds to the voltage range in which to write data. When programming by using the dedicated flash memory programmer, the mode is automatically selected by the voltage setting on GUI.

**Remarks 1.** Using both the wide voltage mode and full speed mode imposes no restrictions on writing, deletion, or verification.

**2.** For details about communication commands, see **25.5.4 Communication commands**.

### 25.5.3 Selecting communication mode

Communication mode of the RL78/G13 as follows.

**Table 25-6. Communication Modes**

Communication Mode	Standard Setting <sup>Note 1</sup>				Pins Used
	Port	Speed <sup>Note 2</sup>	Frequency	Multiply Rate	
1-line mode (when flash memory programmer is used)	UART	115200 bps, 250000 bps, 500000 bps, 1 Mbps	–	–	TOOL0
Dedicated UART (when external device is used)	UART	115200 bps, 250000 bps, 500000 bps, 1 Mbps	–	–	TOOLTxD, TOOLRxD

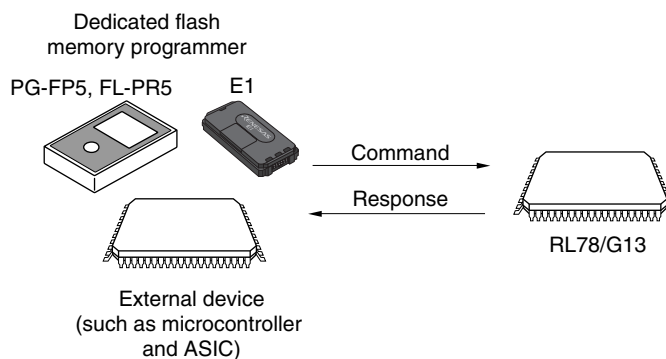
**Notes 1.** Selection items for Standard settings on GUI of the flash memory programmer.

**2.** Because factors other than the baud rate error, such as the signal waveform slew, also affect UART communication, thoroughly evaluate the slew as well as the baud rate error.

**25.5.4 Communication commands**

The RL78/G13 communicates with the dedicated flash memory programmer or external device by using commands. The signals sent from the flash memory programmer or external device to the RL78/G13 are called commands, and the signals sent from the RL78/G13 to the dedicated flash memory programmer or external device are called response.

**Figure 25-9. Communication Commands**



The flash memory control commands of the RL78/G13 are listed in the table below. All these commands are issued from the programmer or external device, and the RL78/G13 perform processing corresponding to the respective commands.

**Table 25-7. Flash Memory Control Commands**

Classification	Command Name	Function
Verify	Verify	Compares the contents of a specified area of the flash memory with data transmitted from the programmer.
Erase	Block Erase	Erases a specified area in the flash memory.
Blank check	Block Blank Check	Checks if a specified block in the flash memory has been correctly erased.
Write	Programming	Writes data to a specified area in the flash memory.
Getting information	Silicon Signature	Gets the RL78/G13 information (such as the part number, flash memory configuration, and programming firmware version).
	Checksum	Gets the checksum data for a specified area.
Security	Security Set	Sets security information.
	Security Get	Gets security information.
	Security Release	Release setting of prohibition of writing.
Others	Reset	Used to detect synchronization status of communication.
	Baud Rate Set	Sets baud rate when UART communication mode is selected.

The RL78/G13 returns a response for the command issued by the dedicated flash memory programmer or external device. The response names sent from the RL78/G13 are listed below.

**Table 25-8. Response Names**

Response Name	Function
ACK	Acknowledges command/data.
NAK	Acknowledges illegal command/data.

**<R> 25.5.5 Description of signature data**

When the “silicon signature” command is performed, the RL78/G13 information (such as the part number, flash memory configuration, and programming firmware version) can be obtained.

Table 25-9 and 25-10 show signature data list and example of signature data list.

**Table 25-9. Signature Data List**

Field name	Description	Number of transmit data
Device code	The serial number assigned to the device	3 bytes
Device name	Device name (ASCII code)	10 bytes
Code flash memory area last address	Last address of code flash memory area (Sent from lower address. Example. 00000H to 0FFFFH (64 KB) → FFH, 1FH, 00H)	3 bytes
Data flash memory area last address	Last address of data flash memory area (Sent from lower address. Example. F1000H to F1FFFH (4 KB) → FFH, 1FH, 0FH)	3 bytes
Firmware version	Version information of firmware for programming (Sent from upper address. Example. From Ver. 1.23 → 01H, 02H, 03H)	3 bytes

**Table 25-10. Example of Signature Data**

Field name	Description	Number of transmit data	Data (hexadecimal)
Device code	Serial number	3 bytes	10 00 03
Device name	RSF100LE	10 bytes	52 = “R” 35 = “S” 46 = “F” 31 = “1” 30 = “0” 30 = “0” 4C = “L” 45 = “E” 20 = “ ” 20 = “ ”
Code flash memory area last address	Code flash memory area 00000H to 0FFFFH (64 KB)	3 bytes	FF FF 00
Data flash memory area last address	Data flash memory area F1000H to F1FFFH (4 KB)	3 bytes	FF 1F 0F
Firmware version	Ver.1.23	3 bytes	01 02 03

## 25.6 Security Settings

The RL78/G13 supports a security function that prohibits rewriting the user program written to the internal flash memory, so that the program cannot be changed by an unauthorized person.

The operations shown below can be performed using the Security Set command. The security setting is valid when the programming mode is set next.

- Disabling block erase  
Execution of the block erase command for a specific block in the flash memory is prohibited during on-board/off-board programming. However, blocks can be erased by means of self programming.
- Disabling write  
Execution of the write command for entire blocks in the flash memory is prohibited during on-board/off-board programming. However, blocks can be written by means of self programming.
- Disabling rewriting boot cluster 0  
Execution of the block erase command and write command on boot cluster 0 (00000H to 00FFFH) in the flash memory is prohibited by this setting.

The block erase, write commands and rewriting boot cluster 0 are enabled by the default setting when the flash memory is shipped. Security can be set by on-board/off-board programming and self programming. Each security setting can be used in combination.

Table 25-11 shows the relationship between the erase and write commands when the RL78/G13 security function is enabled.

**Remark** To prohibit writing and erasing during self-programming, use the flash sealed window function (see **25.7.2** for detail).

**Table 25-11. Relationship Between Enabling Security Function and Command**

**(1) During on-board/off-board programming**

Valid Security	Executed Command	
	Block Erase	Write
Prohibition of block erase	Blocks cannot be erased.	Can be performed. <sup>Note</sup>
Prohibition of writing	Blocks can be erased.	Cannot be performed.
Prohibition of rewriting boot cluster 0	Boot cluster 0 cannot be erased.	Boot cluster 0 cannot be written.

**Note** Confirm that no data has been written to the write area. Because data cannot be erased after block erase is prohibited, do not write data if the data has not been erased.

**(2) During self programming**

Valid Security	Executed Command	
	Block Erase	Write
Prohibition of block erase	Blocks can be erased.	Can be performed.
Prohibition of writing		
Prohibition of rewriting boot cluster 0	Boot cluster 0 cannot be erased.	Boot cluster 0 cannot be written.

**Remark** To prohibit writing and erasing during self-programming, use the flash sealed window function (see 25.7.2 for detail).

**Table 25-12. Setting Security in Each Programming Mode**

**(1) On-board/off-board programming**

Security	Security Setting	How to Disable Security Setting
Prohibition of block erase	Set via GUI of dedicated flash memory programmer, etc.	Cannot be disabled after set.
Prohibition of writing		Execute security release command
Prohibition of rewriting boot cluster 0		Cannot be disabled after set.

**Caution** The security release command can be applied only when the security is not set as the block erase prohibition and the boot cluster 0 rewrite prohibition with code flash memory area and data flash memory area being blanks.

**(2) Self programming**

Security	Security Setting	How to Disable Security Setting
Prohibition of block erase	Set by using flash self programming library.	Cannot be disabled after set.
Prohibition of writing		Execute security release command during on-board/off-board programming (cannot be disabled during self programming)
Prohibition of rewriting boot cluster 0		Cannot be disabled after set.

## 25.7 Flash Memory Programming by Self-Programming

The RL78/G13 supports a self-programming function that can be used to rewrite the flash memory via a user program. Because this function allows a user application to rewrite the flash memory by using the RL78/G13 self-programming library, it can be used to upgrade the program in the field.

- Cautions**
1. The self-programming function cannot be used when the CPU operates with the subsystem clock.
  2. To prohibit an interrupt during self-programming, in the same way as in the normal operation mode, execute the self-programming library in the state where the IE flag is cleared (0) by the DI instruction. To enable an interrupt, clear (0) the interrupt mask flag to accept in the state where the IE flag is set (1) by the EI instruction, and then execute the self-programming library.
  3. When enabling RAM parity error resets (RPERDIS = 1), be sure to initialize the RAM area to use + 10 bytes before overwriting.

- Remarks**
1. For details of the self-programming function and the RL78/G13 self-programming library, refer to **RL78 Microcontroller Self Programming Library Type01 User's Manual (R01AN0350E)**.
  2. For details of the time required to execute self programming, see the notes on use that accompany the flash self programming library tool.

Similar to when writing data by using the flash memory programmer, there are two flash memory programming modes for which the voltage range in which to write, erase, or verify data differs.

**Table 25-13. Programming Modes and Voltages at Which Data Can Be Written, Erased, or Verified**

Mode	Voltages at which data can be written, erased, or verified	Writing Clock Frequency
Wide voltage mode	1.8 V to 5.5 V	8 MHz (MAX.)
Full speed mode <sup>Note</sup>	2.4 V to 5.5 V	16 MHz (MAX.)
	2.7 V to 5.5 V	32 MHz (MAX.)

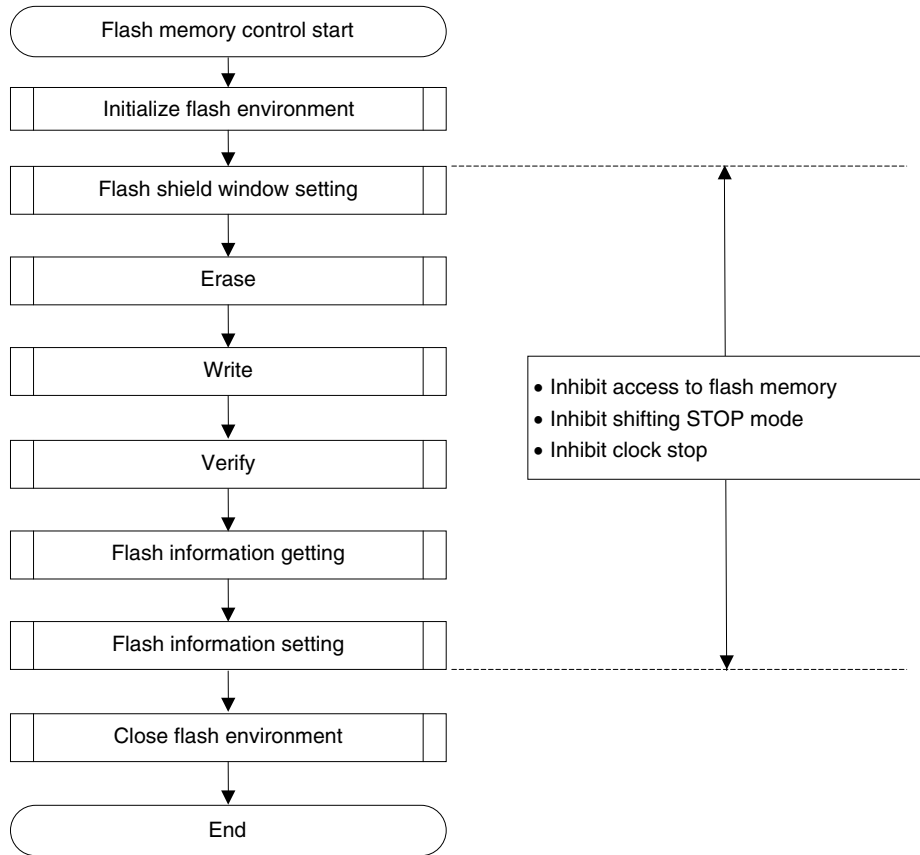
**Note** This can only be specified if the CMODE1 and CMODE0 bits of the option byte 000C2H are 1.

Specify the mode that corresponds to the voltage range in which to write data. If the argument `fsl_flash_voltage_u08` is other than 00H when the `FSL_Init` function of the self programming library provided by Renesas Electronics is executed, wide-voltage mode is specified. If the argument is 00H, full-speed mode is specified.

- Remarks**
1. Using both the wide voltage mode and full speed mode imposes no restrictions on writing, deletion, or verification.
  2. For details of the self-programming function and the RL78/G13 self-programming library, refer to **RL78 Microcontroller Self Programming Library Type01 User's Manual (R01AN0350E)**.

The following figure illustrates a flow of rewriting the flash memory by using a self programming library.

**Figure 25-10. Flow of Self Programming (Rewriting Flash Memory)**



**25.7.1 Boot swap function**

If rewriting the boot area failed by temporary power failure or other reasons, restarting a program by resetting or overwriting is disabled due to data destruction in the boot area.

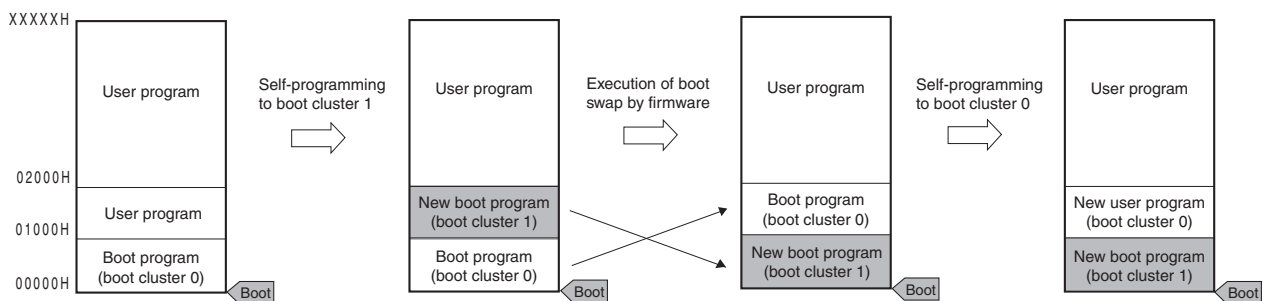
The boot swap function is used to avoid this problem.

Before erasing boot cluster 0<sup>Note</sup>, which is a boot program area, by self-programming, write a new boot program to boot cluster 1 in advance. When the program has been correctly written to boot cluster 1, swap this boot cluster 1 and boot cluster 0 by using the set information function of the firmware of the RL78/G13, so that boot cluster 1 is used as a boot area. After that, erase or write the original boot program area, boot cluster 0.

As a result, even if a power failure occurs while the boot programming area is being rewritten, the program is executed correctly because it is booted from boot cluster 1 to be swapped when the program is reset and started next.

**Note** A boot cluster is a 4 KB area and boot clusters 0 and 1 are swapped by the boot swap function.

**Figure 25-11. Boot Swap Function**



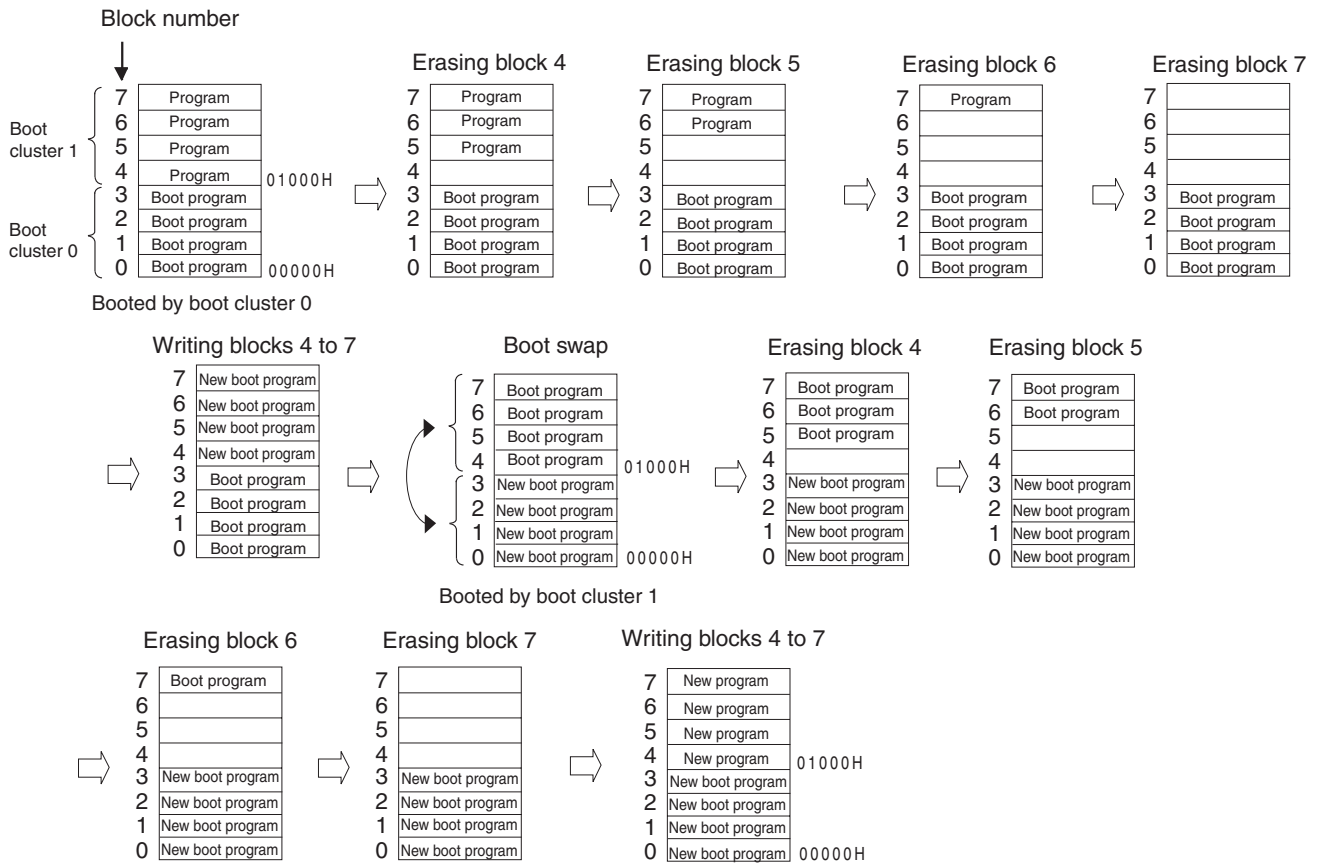
In an example of above figure, it is as follows.

Boot cluster 0: Boot program area before boot swap

Boot cluster 1: Boot program area after boot swap



Figure 25-12. Example of Executing Boot Swapping



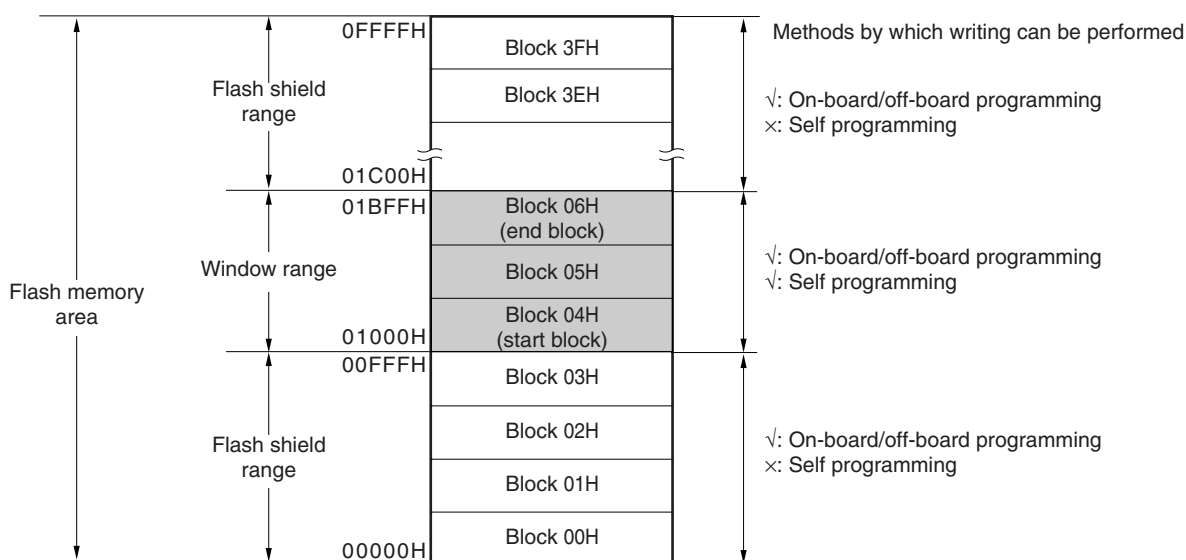
**25.7.2 Flash shield window function**

The flash shield window function is provided as one of the security functions for self programming. It disables writing to and erasing areas outside the range specified as a window only during self programming.

The window range can be set by specifying the start and end blocks. The window range can be set or changed during both on-board/off-board programming and self programming.

Writing to and erasing areas outside the window range are disabled during self programming. During on-board/off-board programming, however, areas outside the range specified as a window can be written and erased.

**Figure 25-13. Flash Shield Window Setting Example**  
**(Target Devices: R5F100LE, Start Block: 04H, End Block: 06H)**



- Cautions**
1. If the rewrite-prohibited area of the boot cluster 0 overlaps with the flash shield window range, prohibition to rewrite the boot cluster 0 takes priority.
  2. The flash shield window can only be used for the code flash memory (and is not supported for the data flash memory).

**Table 25-14. Relationship between Flash Shield Window Function Setting/Change Methods and Commands**

Programming conditions	Window Range Setting/Change Methods	Execution Commands	
		Block erase	Write
Self-programming	Specify the starting and ending blocks by the flash self programming library.	Block erasing is enabled only within the window range.	Writing is enabled only within the range of window range.
On-board/Off-board programming	Specify the starting and ending blocks on GUI of dedicated flash memory programmer, etc.	Block erasing is enabled also outside the window range.	Writing is enabled also outside the window range.

<R>

**Remark** See 25.6 Security Settings to prohibit writing/erasing during on-board/off-board programming.

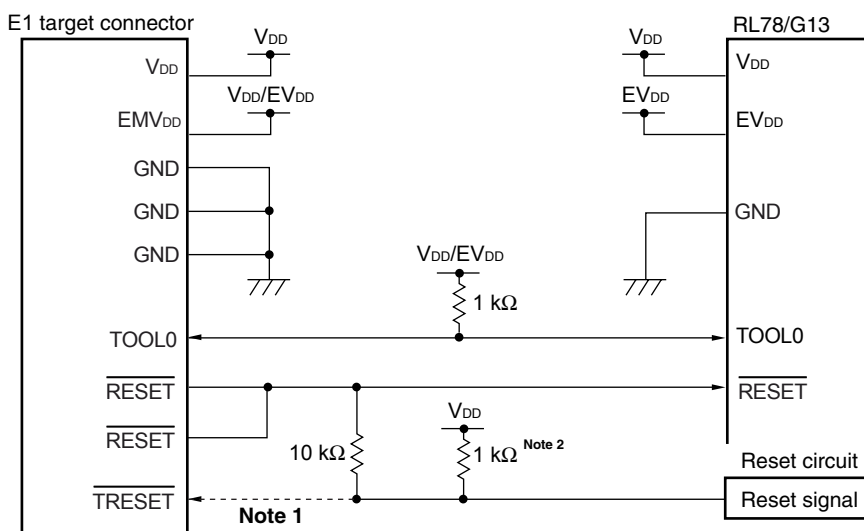
CHAPTER 26 ON-CHIP DEBUG FUNCTION

26.1 Connecting E1 On-chip Debugging Emulator to RL78/G13

The RL78/G13 uses the  $V_{DD}$ ,  $\overline{\text{RESET}}$ , TOOL0, and  $V_{SS}$  pins to communicate with the host machine via an E1 on-chip debugging emulator. Serial communication is performed by using a single-line UART that uses the TOOL0 pin.

**Caution** The RL78/G13 has an on-chip debug function, which is provided for development and evaluation. Do not use the on-chip debug function in products designated for mass production, because the guaranteed number of rewritable times of the flash memory may be exceeded when this function is used, and product reliability therefore cannot be guaranteed. Renesas Electronics is not liable for problems occurring when the on-chip debug function is used.

Figure 26-1. Connection Example of E1 On-chip Debugging Emulator and RL78/G13



- Notes**
1. Connecting the dotted line is not necessary during flash programming.
  2. If the reset circuit on the target system does not have a buffer and generates a reset signal only with resistors and capacitors, this pull-up resistor is not necessary.

**Caution** This circuit diagram is assumed that the reset signal outputs from an N-ch O.D. buffer (output resistor: 100 Ω or less)

## 26.2 On-Chip Debug Security ID

The RL78/G13 has an on-chip debug operation control bit in the flash memory at 000C3H (see **CHAPTER 24 OPTION BYTE**) and an on-chip debug security ID setting area at 000C4H to 000CDH, to prevent third parties from reading memory content.

When the boot swap function is used, also set a value that is the same as that of 010C3H and 010C4H to 010CDH in advance, because 000C3H, 000C4H to 000CDH and 010C3H, and 010C4H to 010CDH are switched.

**Table 26-1. On-Chip Debug Security ID**

Address	On-Chip Debug Security ID
000C4H to 000CDH	Any ID code of 10 bytes
010C4H to 010CDH	

## 26.3 Securing of User Resources

To perform communication between the RL78/G13 and E1 on-chip debugging emulator, as well as each debug function, the securing of memory space must be done beforehand.

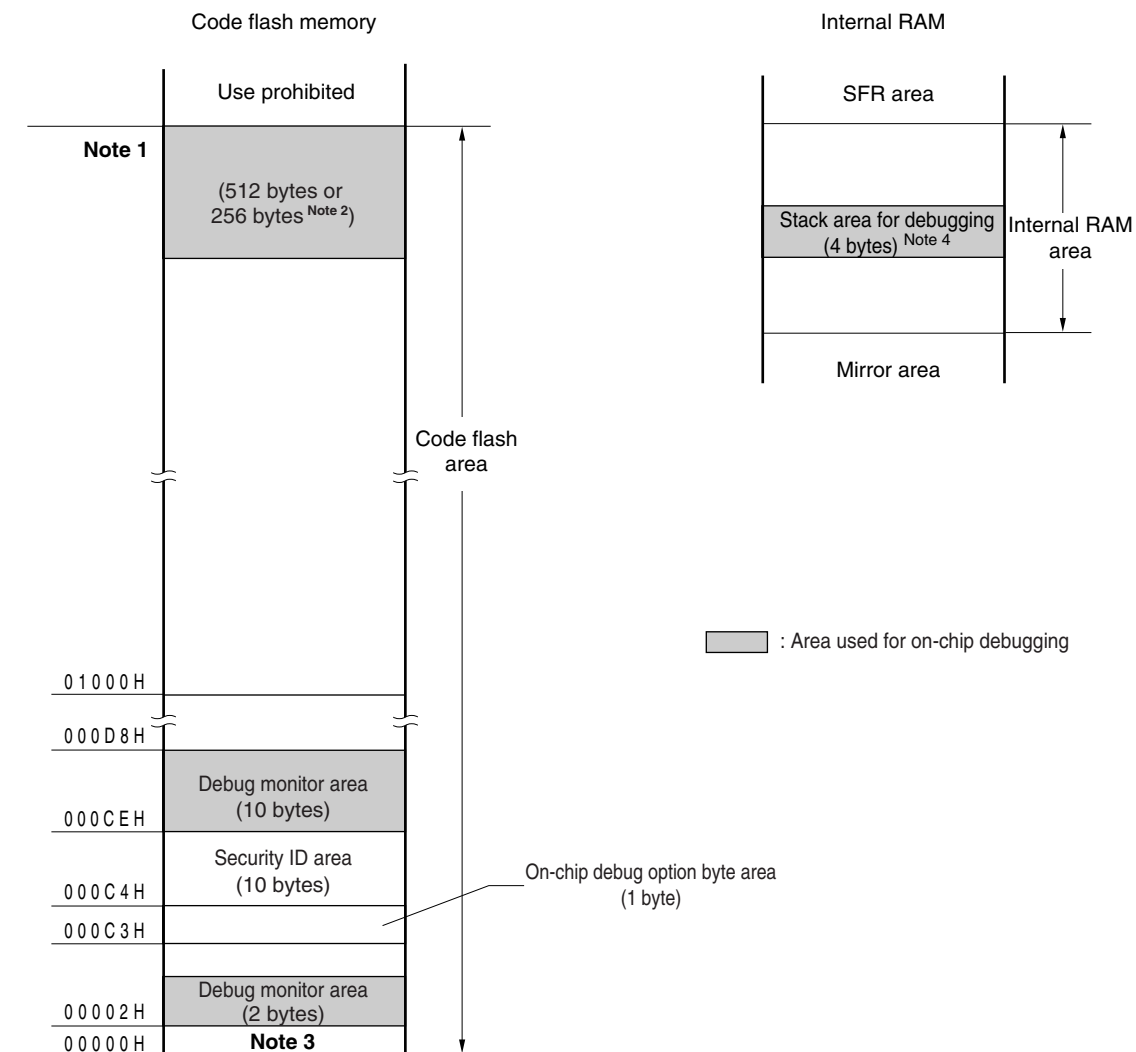
If Renesas Electronics assembler or compiler is used, the items can be set by using linker options.

### (1) Securement of memory space

The shaded portions in Figure 26-2 are the areas reserved for placing the debug monitor program, so user programs or data cannot be allocated in these spaces. When using the on-chip debug function, these spaces must be secured so as not to be used by the user program. Moreover, this area must not be rewritten by the user program.

<R>

**Figure 26-2. Memory Spaces Where Debug Monitor Programs Are Allocated**



**Notes 1.** Address differs depending on products as follows.

Products (code flash memory capacity)	Address of <b>Note 1</b>
R5F100xA, R5F101xA (x = 6 to 8, A to C, E to G)	03FFFFH
R5F100xC, R5F101xC (x = 6 to 8, A to C, E to G, J, L)	07FFFFH
R5F100xD, R5F101xD (x = 6 to 8, A to C, E to G, J, L)	0BFFFFH
R5F100xE, R5F101xE (x = 6 to 8, A to C, E to G, J, L)	0FFFFFFH
R5F100xF, R5F101xF (x = A to C, E to G, J, L, M, P)	17FFFFH
R5F100xG, R5F101xG (x = A to C, E to G, J, L, M, P)	1FFFFFFH
R5F100xH, R5F101xH (x = E to G, J, L, M, P, S)	2FFFFFFH
R5F100xJ, R5F101xJ (x = F, G, J, L, M, P, S)	3FFFFFFH
R5F100xK, R5F101xK (x = F, G, J, L, M, P, S)	5FFFFFFH
R5F100xL, R5F101xL (x = F, G, J, L, M, P, S)	7FFFFFFH

- When real-time RAM monitor (RRM) function and dynamic memory modification (DMM) function are not used, it is 256 bytes.
- In debugging, reset vector is rewritten to address allocated to a monitor program.
- Since this area is allocated immediately before the stack area, the address of this area varies depending on the stack increase and decrease. That is, 4 extra bytes are consumed for the stack area used. When using self-programming, 12 extra bytes are consumed for the stack area used.

## CHAPTER 27 BCD CORRECTION CIRCUIT

### 27.1 BCD Correction Circuit Function

The result of addition/subtraction of the BCD (binary-coded decimal) code and BCD code can be obtained as BCD code with this circuit.

The decimal correction operation result is obtained by performing addition/subtraction having the A register as the operand and then adding/ subtracting the BCD correction result register (BCDADJ).

### 27.2 Registers Used by BCD Correction Circuit

The BCD correction circuit uses the following registers.

- BCD correction result register (BCDADJ)

#### (1) BCD correction result register (BCDADJ)

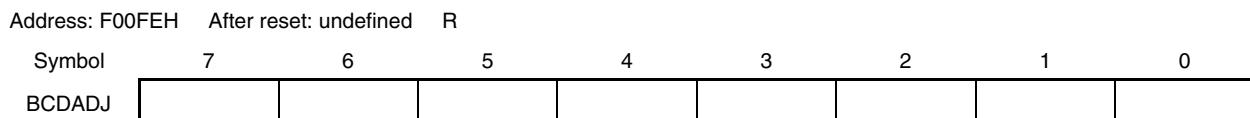
The BCDADJ register stores correction values for obtaining the add/subtract result as BCD code through add/subtract instructions using the A register as the operand.

The value read from the BCDADJ register varies depending on the value of the A register when it is read and those of the CY and AC flags.

The BCDADJ register is read by an 8-bit memory manipulation instruction.

Reset input sets this register to undefined.

**Figure 27-1. Format of BCD Correction Result Register (BCDADJ)**



### 27.3 BCD Correction Circuit Operation

The basic operation of the BCD correction circuit is as follows.

**(1) Addition: Calculating the result of adding a BCD code value and another BCD code value by using a BCD code value**

- <1> The BCD code value to which addition is performed is stored in the A register.
- <2> By adding the value of the A register and the second operand (value of one more BCD code to be added) as are in binary, the binary operation result is stored in the A register and the correction value is stored in the BCD correction result register (BCDADJ).
- <3> Decimal correction is performed by adding in binary the value of the A register (addition result in binary) and the BCDADJ register (correction value), and the correction result is stored in the A register and CY flag.

**Caution** The value read from the BCDADJ register varies depending on the value of the A register when it is read and those of the CY and AC flags. Therefore, execute the instruction <3> after the instruction <2> instead of executing any other instructions. To perform BCD correction in the interrupt enabled state, saving and restoring the A register is required within the interrupt function. PSW (CY flag and AC flag) is restored by the RETI instruction.

An example is shown below.

Examples 1: 99 + 89 = 188

Instruction	A Register	CY Flag	AC Flag	BCDADJ Register
MOV A, #99H ; <1>	99H	–	–	–
ADD A, #89H ; <2>	22H	1	1	66H
ADD A, !BCDADJ ; <3>	88H	1	0	–

Examples 2: 85 + 15 = 100

Instruction	A Register	CY Flag	AC Flag	BCDADJ Register
MOV A, #85H ; <1>	85H	–	–	–
ADD A, #15H ; <2>	9AH	0	0	66H
ADD A, !BCDADJ ; <3>	00H	1	1	–

Examples 3: 80 + 80 = 160

Instruction	A Register	CY Flag	AC Flag	BCDADJ Register
MOV A, #80H ; <1>	80H	–	–	–
ADD A, #80H ; <2>	00H	1	0	60H
ADD A, !BCDADJ ; <3>	60H	1	0	–

**(2) Subtraction: Calculating the result of subtracting a BCD code value from another BCD code value by using a BCD code value**

- <1> The BCD code value from which subtraction is performed is stored in the A register.
- <2> By subtracting the value of the second operand (value of BCD code to be subtracted) from the A register as is in binary, the calculation result in binary is stored in the A register, and the correction value is stored in the BCD correction result register (BCDADJ).
- <3> Decimal correction is performed by subtracting the value of the BCDADJ register (correction value) from the A register (subtraction result in binary) in binary, and the correction result is stored in the A register and CY flag.

**Caution** The value read from the BCDADJ register varies depending on the value of the A register when it is read and those of the CY and AC flags. Therefore, execute the instruction <3> after the instruction <2> instead of executing any other instructions. To perform BCD correction in the interrupt enabled state, saving and restoring the A register is required within the interrupt function. PSW (CY flag and AC flag) is restored by the RETI instruction.

An example is shown below.

Example:  $91 - 52 = 39$

Instruction	A Register	CY Flag	AC Flag	BCDADJ Register
MOV A, #91H ; <1>	91H	–	–	–
SUB A, #52H ; <2>	3FH	0	1	06H
SUB A, !BCDADJ ; <3>	39H	0	0	–



## CHAPTER 28 INSTRUCTION SET

This chapter lists the instructions in the RL78 microcontroller instruction set. For details of each operation and <R> operation code, refer to the separate document **RL78 Microcontrollers User's Manual: software**.

## 28.1 Conventions Used in Operation List

### 28.1.1 Operand identifiers and specification methods

Operands are described in the “Operand” column of each instruction in accordance with the description method of the instruction operand identifier (refer to the assembler specifications for details). When there are two or more description methods, select one of them. Alphabetic letters in capitals and the symbols, #, !, !!, \$, \$!, [ ], and ES: are keywords and are described as they are. Each symbol has the following meaning.

- #: Immediate data specification
- !: 16-bit absolute address specification
- !!: 20-bit absolute address specification
- \$: 8-bit relative address specification
- \$!: 16-bit relative address specification
- [ ]: Indirect address specification
- ES:: Extension address specification

In the case of immediate data, describe an appropriate numeric value or a label. When using a label, be sure to describe the #, !, !!, \$, \$!, [ ], and ES: symbols.

For operand register identifiers, r and rp, either function names (X, A, C, etc.) or absolute names (names in parentheses in the table below, R0, R1, R2, etc.) can be used for description.

**Table 28-1. Operand Identifiers and Specification Methods**

Identifier	Description Method
r	X (R0), A (R1), C (R2), B (R3), E (R4), D (R5), L (R6), H (R7)
rp	AX (RP0), BC (RP1), DE (RP2), HL (RP3)
sfr	Special-function register symbol (SFR symbol) FFF00H to FFFFFH
sfrp	Special-function register symbols (16-bit manipulatable SFR symbol. Even addresses only <sup>Note</sup> ) FFF00H to FFFFFH
saddr	FFE20H to FFF1FH Immediate data or labels
saddrp	FFE20H to FF1FH Immediate data or labels (even addresses only <sup>Note</sup> )
addr20	00000H to FFFFFH Immediate data or labels
addr16	0000H to FFFFH Immediate data or labels (only even addresses for 16-bit data transfer instructions <sup>Note</sup> )
addr5	0080H to 00BFH Immediate data or labels (even addresses only)
word	16-bit immediate data or label
byte	8-bit immediate data or label
bit	3-bit immediate data or label
RBn	RB0 to RB3

**Note** Bit 0 = 0 when an odd address is specified.

**Remark** The special function registers can be described to operand sfr as symbols. See **Table 3-5 SFR List** for the symbols of the special function registers. The extended special function registers can be described to operand laddr16 as symbols. See **Table 3-6 Extended SFR (2nd SFR) List** for the symbols of the extended special function registers.

### 28.1.2 Description of operation column

The operation when the instruction is executed is shown in the “Operation” column using the following symbols.

**Table 28-2. Symbols in “Operation” Column**

Symbol	Function
A	A register; 8-bit accumulator
X	X register
B	B register
C	C register
D	D register
E	E register
H	H register
L	L register
ES	ES register
CS	CS register
AX	AX register pair; 16-bit accumulator
BC	BC register pair
DE	DE register pair
HL	HL register pair
PC	Program counter
SP	Stack pointer
PSW	Program status word
CY	Carry flag
AC	Auxiliary carry flag
Z	Zero flag
RBS	Register bank select flag
IE	Interrupt request enable flag
()	Memory contents indicated by address or register contents in parentheses
X <sub>H</sub> , X <sub>L</sub>	16-bit registers: X <sub>H</sub> = higher 8 bits, X <sub>L</sub> = lower 8 bits
X <sub>S</sub> , X <sub>H</sub> , X <sub>L</sub>	20-bit registers: X <sub>S</sub> = (bits 19 to 16), X <sub>H</sub> = (bits 15 to 8), X <sub>L</sub> = (bits 7 to 0)
∧	Logical product (AND)
∨	Logical sum (OR)
⊕	Exclusive logical sum (exclusive OR)
–	Inverted data
addr5	16-bit immediate data (even addresses only in 0080H to 00BFH)
addr16	16-bit immediate data
addr20	20-bit immediate data
jdisp8	Signed 8-bit data (displacement value)
jdisp16	Signed 16-bit data (displacement value)

### 28.1.3 Description of flag operation column

The change of the flag value when the instruction is executed is shown in the “Flag” column using the following symbols.

**Table 28-3. Symbols in “Flag” Column**

Symbol	Change of Flag Value
(Blank)	Unchanged
0	Cleared to 0
1	Set to 1
×	Set/cleared according to the result
R	Previously saved value is restored

### 28.1.4 PREFIX instruction

Instructions with “ES:” have a PREFIX operation code as a prefix to extend the accessible data area to the 1 MB space (00000H to FFFFFH), by adding the ES register value to the 64 KB space from F0000H to FFFFFH. When a PREFIX operation code is attached as a prefix to the target instruction, only one instruction immediately after the PREFIX operation code is executed as the addresses with the ES register value added.

A interrupt and DMA transfer are not acknowledged between a PREFIX instruction code and the instruction immediately after.

**Table 28-4. Use Example of PREFIX Operation Code**

Instruction	Opcode				
	1	2	3	4	5
MOV !addr16, #byte	CFH	!addr16		#byte	–
MOV ES:!addr16, #byte	11H	CFH	!addr16		#byte
MOV A, [HL]	8BH	–	–	–	–
MOV A, ES:[HL]	11H	8BH	–	–	–

**Caution** Set the ES register value with MOV ES, A, etc., before executing the PREFIX instruction.

<R> 28.2 Operation List

Table 28-5. Operation List (1/17)

Instruction Group	Mnemonic	Operands	Bytes	Clocks		Operands	Flag
				Note 1	Note 2		
8-bit data transfer	MOV	r, #byte	2	1	-	r ← byte	
		PSW, #byte	3	3	-	PSW ← byte	x x x
		CS, #byte	3	1	-	CS ← byte	
		ES, #byte	2	1	-	ES ← byte	
		!addr16, #byte	4	1	-	(addr16) ← byte	
		ES:!addr16, #byte	5	2	-	(ES, addr16) ← byte	
		saddr, #byte	3	1	-	(saddr) ← byte	
		sfr, #byte	3	1	-	sfr ← byte	
		[DE+byte], #byte	3	1	-	(DE+byte) ← byte	
		ES:[DE+byte], #byte	4	2	-	((ES, DE)+byte) ← byte	
		[HL+byte], #byte	3	1	-	(HL+byte) ← byte	
		ES:[HL+byte], #byte	4	2	-	((ES, HL)+byte) ← byte	
		[SP+byte], #byte	3	1	-	(SP+byte) ← byte	
		word[B], #byte	4	1	-	(B+word) ← byte	
		ES:word[B], #byte	5	2	-	((ES, B)+word) ← byte	
		word[C], #byte	4	1	-	(C+word) ← byte	
		ES:word[C], #byte	5	2	-	((ES, C)+word) ← byte	
		word[BC], #byte	4	1	-	(BC+word) ← byte	
		ES:word[BC], #byte	5	2	-	((ES, BC)+word) ← byte	
		A, r <sup>Note 3</sup>	1	1	-	A ← r	
		r, A <sup>Note 3</sup>	1	1	-	r ← A	
		A, PSW	2	1	-	A ← PSW	
		PSW, A	2	3	-	PSW ← A	x x x
		A, CS	2	1	-	A ← CS	
		CS, A	2	1	-	CS ← A	
		A, ES	2	1	-	A ← ES	
		ES, A	2	1	-	ES ← A	
		A, !addr16	3	1	4	A ← (addr16)	
		A, ES:!addr16	4	2	5	A ← (ES, addr16)	
		!addr16, A	3	1	-	(addr16) ← A	
ES:!addr16, A	4	2	-	(ES, addr16) ← A			
A, saddr	2	1	-	A ← (saddr)			
saddr, A	2	1	-	(saddr) ← A			

- Notes 1.** Number of CPU clocks (f<sub>CLK</sub>) when the internal RAM area, SFR area, or extended SFR area is accessed, or when no data is accessed.
- 2.** Number of CPU clocks (f<sub>CLK</sub>) when the program memory area is accessed.
- 3.** Except r = A

**Remark** Number of clock is when program exists in the internal ROM (flash memory) area. If fetching the instruction from the internal RAM area, the number becomes double number plus 3 clocks at a maximum.

Table 28-5. Operation List (2/17)

Instruction Group	Mnemonic	Operands	Bytes	Clocks		Clocks	Flag		
				Note 1	Note 2		Z	AC	CY
8-bit data transfer	MOV	A, sfr	2	1	–	A ← sfr			
		sfr, A	2	1	–	sfr ← A			
		A, [DE]	1	1	4	A ← (DE)			
		[DE], A	1	1	–	(DE) ← A			
		A, ES:[DE]	2	2	5	A ← (ES, DE)			
		ES:[DE], A	2	2	–	(ES, DE) ← A			
		A, [HL]	1	1	4	A ← (HL)			
		[HL], A	1	1	–	(HL) ← A			
		A, ES:[HL]	2	2	5	A ← (ES, HL)			
		ES:[HL], A	2	2	–	(ES, HL) ← A			
		A, [DE+byte]	2	1	4	A ← (DE + byte)			
		[DE+byte], A	2	1	–	(DE + byte) ← A			
		A, ES:[DE+byte]	3	2	5	A ← ((ES, DE) + byte)			
		ES:[DE+byte], A	3	2	–	((ES, DE) + byte) ← A			
		A, [HL+byte]	2	1	4	A ← (HL + byte)			
		[HL+byte], A	2	1	–	(HL + byte) ← A			
		A, ES:[HL+byte]	3	2	5	A ← ((ES, HL) + byte)			
		ES:[HL+byte], A	3	2	–	((ES, HL) + byte) ← A			
		A, [SP+byte]	2	1	–	A ← (SP + byte)			
		[SP+byte], A	2	1	–	(SP + byte) ← A			
		A, word[B]	3	1	4	A ← (B + word)			
		word[B], A	3	1	–	(B + word) ← A			
		A, ES:word[B]	4	2	5	A ← ((ES, B) + word)			
		ES:word[B], A	4	2	–	((ES, B) + word) ← A			
		A, word[C]	3	1	4	A ← (C + word)			
		word[C], A	3	1	–	(C + word) ← A			
		A, ES:word[C]	4	2	5	A ← ((ES, C) + word)			
		ES:word[C], A	4	2	–	((ES, C) + word) ← A			
		A, word[BC]	3	1	4	A ← (BC + word)			
		word[BC], A	3	1	–	(BC + word) ← A			
		A, ES:word[BC]	4	2	5	A ← ((ES, BC) + word)			
		ES:word[BC], A	4	2	–	((ES, BC) + word) ← A			

**Notes 1.** Number of CPU clocks ( $f_{CLK}$ ) when the internal RAM area, SFR area, or extended SFR area is accessed, or when no data is accessed.

**2.** Number of CPU clocks ( $f_{CLK}$ ) when the program memory area is accessed.

**Remark** Number of clock is when program exists in the internal ROM (flash memory) area. If fetching the instruction from the internal RAM area, the number becomes double number plus 3 clocks at a maximum.

Table 28-5. Operation List (3/17)

Instruction Group	Mnemonic	Operands	Bytes	Clocks		Clocks	Flag		
				Note 1	Note 2		Z	AC	CY
8-bit data transfer	MOV	A, [HL+B]	2	1	4	$A \leftarrow (HL + B)$			
		[HL+B], A	2	1	–	$(HL + B) \leftarrow A$			
		A, ES:[HL+B]	3	2	5	$A \leftarrow ((ES, HL) + B)$			
		ES:[HL+B], A	3	2	–	$((ES, HL) + B) \leftarrow A$			
		A, [HL+C]	2	1	4	$A \leftarrow (HL + C)$			
		[HL+C], A	2	1	–	$(HL + C) \leftarrow A$			
		A, ES:[HL+C]	3	2	5	$A \leftarrow ((ES, HL) + C)$			
		ES:[HL+C], A	3	2	–	$((ES, HL) + C) \leftarrow A$			
		X, laddr16	3	1	4	$X \leftarrow (addr16)$			
		X, ES:laddr16	4	2	5	$X \leftarrow (ES, addr16)$			
		X, saddr	2	1	–	$X \leftarrow (saddr)$			
		B, laddr16	3	1	4	$B \leftarrow (addr16)$			
		B, ES:laddr16	4	2	5	$B \leftarrow (ES, addr16)$			
		B, saddr	2	1	–	$B \leftarrow (saddr)$			
		C, laddr16	3	1	4	$C \leftarrow (addr16)$			
		C, ES:laddr16	4	2	5	$C \leftarrow (ES, addr16)$			
	C, saddr	2	1	–	$C \leftarrow (saddr)$				
	ES, saddr	3	1	–	$ES \leftarrow (saddr)$				
	XCH	A, r <sup>Note 3</sup>	1 (r = X) 2 (other than r = X)	1	–	$A \leftrightarrow r$			
		A, laddr16	4	2	–	$A \leftrightarrow (addr16)$			
		A, ES:laddr16	5	3	–	$A \leftrightarrow (ES, addr16)$			
		A, saddr	3	2	–	$A \leftrightarrow (saddr)$			
		A, sfr	3	2	–	$A \leftrightarrow sfr$			
		A, [DE]	2	2	–	$A \leftrightarrow (DE)$			
		A, ES:[DE]	3	3	–	$A \leftrightarrow (ES, DE)$			
		A, [HL]	2	2	–	$A \leftrightarrow (HL)$			
		A, ES:[HL]	3	3	–	$A \leftrightarrow (ES, HL)$			
		A, [DE+byte]	3	2	–	$A \leftrightarrow (DE + \text{byte})$			
A, ES:[DE+byte]		4	3	–	$A \leftrightarrow ((ES, DE) + \text{byte})$				
A, [HL+byte]		3	2	–	$A \leftrightarrow (HL + \text{byte})$				
A, ES:[HL+byte]	4	3	–	$A \leftrightarrow ((ES, HL) + \text{byte})$					

**Notes 1.** Number of CPU clocks ( $f_{CLK}$ ) when the internal RAM area, SFR area, or extended SFR area is accessed, or when no data is accessed.

**2.** Number of CPU clocks ( $f_{CLK}$ ) when the program memory area is accessed.

**3.** Except r = A

**Remark** Number of clock is when program exists in the internal ROM (flash memory) area. If fetching the instruction from the internal RAM area, the number becomes double number plus 3 clocks at a maximum.

Table 28-5. Operation List (4/17)

Instruction Group	Mnemonic	Operands	Bytes	Clocks		Clocks	Flag			
				Note 1	Note 2		Z	AC	CY	
8-bit data transfer	XCH	A, [HL+B]	2	2	–	A ←→ (HL+B)				
		A, ES:[HL+B]	3	3	–	A ←→ ((ES, HL)+B)				
		A, [HL+C]	2	2	–	A ←→ (HL+C)				
		A, ES:[HL+C]	3	3	–	A ←→ ((ES, HL)+C)				
	ONEB	A	1	1	–	A ← 01H				
		X	1	1	–	X ← 01H				
		B	1	1	–	B ← 01H				
		C	1	1	–	C ← 01H				
		!addr16	3	1	–	(addr16) ← 01H				
		ES:!addr16	4	2	–	(ES, addr16) ← 01H				
		saddr	2	1	–	(saddr) ← 01H				
	CLR B	A	1	1	–	A ← 00H				
		X	1	1	–	X ← 00H				
		B	1	1	–	B ← 00H				
		C	1	1	–	C ← 00H				
		!addr16	3	1	–	(addr16) ← 00H				
		ES:!addr16	4	2	–	(ES, addr16) ← 00H				
		saddr	2	1	–	(saddr) ← 00H				
	MOVS	[HL+byte], X	3	1	–	(HL+byte) ← X	x		x	
		ES:[HL+byte], X	4	2	–	(ES, HL+byte) ← X	x		x	
	16-bit data transfer	MOVW	rp, #word	3	1	–	rp ← word			
			saddrp, #word	4	1	–	(saddrp) ← word			
			sfrp, #word	4	1	–	sfrp ← word			
			AX, rp <sup>Note 3</sup>	1	1	–	AX ← rp			
rp, AX <sup>Note 3</sup>			1	1	–	rp ← AX				
AX, !addr16			3	1	4	AX ← (addr16)				
!addr16, AX			3	1	–	(addr16) ← AX				
AX, ES:!addr16			4	2	5	AX ← (ES, addr16)				
ES:!addr16, AX			4	2	–	(ES, addr16) ← AX				
AX, saddrp			2	1	–	AX ← (saddrp)				
saddrp, AX			2	1	–	(saddrp) ← AX				
AX, sfrp			2	1	–	AX ← sfrp				
sfrp, AX			2	1	–	sfrp ← AX				

- Notes 1.** Number of CPU clocks ( $f_{CLK}$ ) when the internal RAM area, SFR area, or extended SFR area is accessed, or when no data is accessed.
- 2.** Number of CPU clocks ( $f_{CLK}$ ) when the program memory area is accessed.
- 3.** Except  $rp = AX$

**Remark** Number of clock is when program exists in the internal ROM (flash memory) area. If fetching the instruction from the internal RAM area, the number becomes double number plus 3 clocks at a maximum.



Table 28-5. Operation List (5/17)

Instruction Group	Mnemonic	Operands	Bytes	Clocks		Clocks	Flag		
				Note 1	Note 2		Z	AC	CY
16-bit data transfer	MOVW	AX, [DE]	1	1	4	AX ← (DE)			
		[DE], AX	1	1	–	(DE) ← AX			
		AX, ES:[DE]	2	2	5	AX ← (ES, DE)			
		ES:[DE], AX	2	2	–	(ES, DE) ← AX			
		AX, [HL]	1	1	4	AX ← (HL)			
		[HL], AX	1	1	–	(HL) ← AX			
		AX, ES:[HL]	2	2	5	AX ← (ES, HL)			
		ES:[HL], AX	2	2	–	(ES, HL) ← AX			
		AX, [DE+byte]	2	1	4	AX ← (DE+byte)			
		[DE+byte], AX	2	1	–	(DE+byte) ← AX			
		AX, ES:[DE+byte]	3	2	5	AX ← ((ES, DE) + byte)			
		ES:[DE+byte], AX	3	2	–	((ES, DE) + byte) ← AX			
		AX, [HL+byte]	2	1	4	AX ← (HL + byte)			
		[HL+byte], AX	2	1	–	(HL + byte) ← AX			
		AX, ES:[HL+byte]	3	2	5	AX ← ((ES, HL) + byte)			
		ES:[HL+byte], AX	3	2	–	((ES, HL) + byte) ← AX			
		AX, [SP+byte]	2	1	–	AX ← (SP + byte)			
		[SP+byte], AX	2	1	–	(SP + byte) ← AX			
		AX, word[B]	3	1	4	AX ← (B + word)			
		word[B], AX	3	1	–	(B+ word) ← AX			
		AX, ES:word[B]	4	2	5	AX ← ((ES, B) + word)			
		ES:word[B], AX	4	2	–	((ES, B) + word) ← AX			
		AX, word[C]	3	1	4	AX ← (C + word)			
		word[C], AX	3	1	–	(C + word) ← AX			
		AX, ES:word[C]	4	2	5	AX ← ((ES, C) + word)			
		ES:word[C], AX	4	2	–	((ES, C) + word) ← AX			
		AX, word[BC]	3	1	4	AX ← (BC + word)			
		word[BC], AX	3	1	–	(BC + word) ← AX			
		AX, ES:word[BC]	4	2	5	AX ← ((ES, BC) + word)			
		ES:word[BC], AX	4	2	–	((ES, BC) + word) ← AX			

**Notes 1.** Number of CPU clocks ( $f_{CLK}$ ) when the internal RAM area, SFR area, or extended SFR area is accessed, or when no data is accessed.

**2.** Number of CPU clocks ( $f_{CLK}$ ) when the program memory area is accessed.

**Remark** Number of clock is when program exists in the internal ROM (flash memory) area. If fetching the instruction from the internal RAM area, the number becomes double number plus 3 clocks at a maximum.

Table 28-5. Operation List (6/17)

Instruction Group	Mnemonic	Operands	Bytes	Clocks		Clocks	Flag		
				Note 1	Note 2		Z	AC	CY
16-bit data transfer	MOVW	BC, !addr16	3	1	4	BC ← (addr16)			
		BC, ES:!addr16	4	2	5	BC ← (ES, addr16)			
		DE, !addr16	3	1	4	DE ← (addr16)			
		DE, ES:!addr16	4	2	5	DE ← (ES, addr16)			
		HL, !addr16	3	1	4	HL ← (addr16)			
		HL, ES:!addr16	4	2	5	HL ← (ES, addr16)			
		BC, saddrp	2	1	–	BC ← (saddrp)			
		DE, saddrp	2	1	–	DE ← (saddrp)			
		HL, saddrp	2	1	–	HL ← (saddrp)			
	XCHW	AX, rp <sup>Note 3</sup>	1	1	–	AX ↔ rp			
	ONEW	AX	1	1	–	AX ← 0001H			
		BC	1	1	–	BC ← 0001H			
	CLRW	AX	1	1	–	AX ← 0000H			
		BC	1	1	–	BC ← 0000H			
8-bit operation	ADD	A, #byte	2	1	–	A, CY ← A + byte	x	x	x
		saddr, #byte	3	2	–	(saddr), CY ← (saddr)+byte	x	x	x
		A, r <sup>Note 4</sup>	2	1	–	A, CY ← A + r	x	x	x
		r, A	2	1	–	r, CY ← r + A	x	x	x
		A, !addr16	3	1	4	A, CY ← A + (addr16)	x	x	x
		A, ES:!addr16	4	2	5	A, CY ← A + (ES, addr16)	x	x	x
		A, saddr	2	1	–	A, CY ← A + (saddr)	x	x	x
		A, [HL]	1	1	4	A, CY ← A + (HL)	x	x	x
		A, ES:[HL]	2	2	5	A, CY ← A + (ES, HL)	x	x	x
		A, [HL+byte]	2	1	4	A, CY ← A + (HL+byte)	x	x	x
		A, ES:[HL+byte]	3	2	5	A, CY ← A + ((ES, HL)+byte)	x	x	x
		A, [HL+B]	2	1	4	A, CY ← A + (HL+B)	x	x	x
		A, ES:[HL+B]	3	2	5	A, CY ← A + ((ES, HL)+B)	x	x	x
		A, [HL+C]	2	1	4	A, CY ← A + (HL+C)	x	x	x
		A, ES:[HL+C]	3	2	5	A, CY ← A + ((ES, HL) + C)	x	x	x

- Notes 1.** Number of CPU clocks ( $f_{CLK}$ ) when the internal RAM area, SFR area, or extended SFR area is accessed, or when no data is accessed.
- 2.** Number of CPU clocks ( $f_{CLK}$ ) when the program memory area is accessed.
- 3.** Except rp = AX
- 4.** Except r = A

**Remark** Number of clock is when program exists in the internal ROM (flash memory) area. If fetching the instruction from the internal RAM area, the number becomes double number plus 3 clocks at a maximum.

Table 28-5. Operation List (7/17)

Instruction Group	Mnemonic	Operands	Bytes	Clocks		Clocks	Flag		
				Note 1	Note 2		Z	AC	CY
8-bit operation	ADDC	A, #byte	2	1	–	A, CY ← A+byte+CY	x	x	x
		saddr, #byte	3	2	–	(saddr), CY ← (saddr) +byte+CY	x	x	x
		A, r <sup>Note 3</sup>	2	1	–	A, CY ← A + r + CY	x	x	x
		r, A	2	1	–	r, CY ← r + A + CY	x	x	x
		A, laddr16	3	1	4	A, CY ← A + (addr16)+CY	x	x	x
		A, ES:!addr16	4	2	5	A, CY ← A + (ES, addr16)+CY	x	x	x
		A, saddr	2	1	–	A, CY ← A + (saddr)+CY	x	x	x
		A, [HL]	1	1	4	A, CY ← A+ (HL) + CY	x	x	x
		A, ES:[HL]	2	2	5	A,CY ← A+ (ES, HL) + CY	x	x	x
		A, [HL+byte]	2	1	4	A, CY ← A+ (HL+byte) + CY	x	x	x
		A, ES:[HL+byte]	3	2	5	A,CY ← A+ ((ES, HL)+byte) + CY	x	x	x
		A, [HL+B]	2	1	4	A, CY ← A+ (HL+B) +CY	x	x	x
		A, ES:[HL+B]	3	2	5	A,CY ← A+((ES, HL)+B)+CY	x	x	x
		A, [HL+C]	2	1	4	A, CY ← A+ (HL+C)+CY	x	x	x
	A, ES:[HL+C]	3	2	5	A,CY ← A+ ((ES, HL)+C)+CY	x	x	x	
	SUB	A, #byte	2	1	–	A, CY ← A – byte	x	x	x
		saddr, #byte	3	2	–	(saddr), CY ← (saddr) – byte	x	x	x
		A, r <sup>Note 3</sup>	2	1	–	A, CY ← A – r	x	x	x
		r, A	2	1	–	r, CY ← r – A	x	x	x
		A, laddr16	3	1	4	A, CY ← A – (addr16)	x	x	x
		A, ES:!addr16	4	2	5	A, CY ← A – (ES, addr16)	x	x	x
		A, saddr	2	1	–	A, CY ← A – (saddr)	x	x	x
		A, [HL]	1	1	4	A, CY ← A – (HL)	x	x	x
		A, ES:[HL]	2	2	5	A,CY ← A – (ES, HL)	x	x	x
		A, [HL+byte]	2	1	4	A, CY ← A – (HL+byte)	x	x	x
		A, ES:[HL+byte]	3	2	5	A,CY ← A – ((ES, HL)+byte)	x	x	x
		A, [HL+B]	2	1	4	A, CY ← A – (HL+B)	x	x	x
		A, ES:[HL+B]	3	2	5	A,CY ← A – ((ES, HL)+B)	x	x	x
A, [HL+C]		2	1	4	A, CY ← A – (HL+C)	x	x	x	
A, ES:[HL+C]	3	2	5	A,CY ← A – ((ES, HL)+C)	x	x	x		

**Notes 1.** Number of CPU clocks ( $f_{CLK}$ ) when the internal RAM area, SFR area, or extended SFR area is accessed, or when no data is accessed.

**2.** Number of CPU clocks ( $f_{CLK}$ ) when the program memory area is accessed.

**3.** Except  $r = A$

**Remark** Number of clock is when program exists in the internal ROM (flash memory) area. If fetching the instruction from the internal RAM area, the number becomes double number plus 3 clocks at a maximum.

Table 28-5. Operation List (8/17)

Instruction Group	Mnemonic	Operands	Bytes	Clocks		Clocks	Flag		
				Note 1	Note 2		Z	AC	CY
8-bit operation	SUBC	A, #byte	2	1	–	A, CY ← A – byte – CY	x	x	x
		saddr, #byte	3	2	–	(saddr), CY ← (saddr) – byte – CY	x	x	x
		A, r <sup>Note 3</sup>	2	1	–	A, CY ← A – r – CY	x	x	x
		r, A	2	1	–	r, CY ← r – A – CY	x	x	x
		A, laddr16	3	1	4	A, CY ← A – (addr16) – CY	x	x	x
		A, ES:!addr16	4	2	5	A, CY ← A – (ES, addr16) – CY	x	x	x
		A, saddr	2	1	–	A, CY ← A – (saddr) – CY	x	x	x
		A, [HL]	1	1	4	A, CY ← A – (HL) – CY	x	x	x
		A, ES:[HL]	2	2	5	A, CY ← A – (ES, HL) – CY	x	x	x
		A, [HL+byte]	2	1	4	A, CY ← A – (HL+byte) – CY	x	x	x
		A, ES:[HL+byte]	3	2	5	A, CY ← A – ((ES, HL)+byte) – CY	x	x	x
		A, [HL+B]	2	1	4	A, CY ← A – (HL+B) – CY	x	x	x
		A, ES:[HL+B]	3	2	5	A, CY ← A – ((ES, HL)+B) – CY	x	x	x
		A, [HL+C]	2	1	4	A, CY ← A – (HL+C) – CY	x	x	x
		A, ES:[HL+C]	3	2	5	A, CY ← A – ((ES:HL)+C) – CY	x	x	x
	AND	A, #byte	2	1	–	A ← A ∧ byte	x		
		saddr, #byte	3	2	–	(saddr) ← (saddr) ∧ byte	x		
		A, r <sup>Note 3</sup>	2	1	–	A ← A ∧ r	x		
		r, A	2	1	–	R ← r ∧ A	x		
		A, laddr16	3	1	4	A ← A ∧ (addr16)	x		
		A, ES:!addr16	4	2	5	A ← A ∧ (ES:addr16)	x		
		A, saddr	2	1	–	A ← A ∧ (saddr)	x		
		A, [HL]	1	1	4	A ← A ∧ (HL)	x		
		A, ES:[HL]	2	2	5	A ← A ∧ (ES:HL)	x		
		A, [HL+byte]	2	1	4	A ← A ∧ (HL+byte)	x		
		A, ES:[HL+byte]	3	2	5	A ← A ∧ ((ES:HL)+byte)	x		
		A, [HL+B]	2	1	4	A ← A ∧ (HL+B)	x		
		A, ES:[HL+B]	3	2	5	A ← A ∧ ((ES:HL)+B)	x		
A, [HL+C]	2	1	4	A ← A ∧ (HL+C)	x				
A, ES:[HL+C]	3	2	5	A ← A ∧ ((ES:HL)+C)	x				

**Notes 1.** Number of CPU clocks ( $f_{CLK}$ ) when the internal RAM area, SFR area, or extended SFR area is accessed, or when no data is accessed.

**2.** Number of CPU clocks ( $f_{CLK}$ ) when the program memory area is accessed.

**3.** Except  $r = A$

**Remark** Number of clock is when program exists in the internal ROM (flash memory) area. If fetching the instruction from the internal RAM area, the number becomes double number plus 3 clocks at a maximum.

Table 28-5. Operation List (9/17)

Instruction Group	Mnemonic	Operands	Bytes	Clocks		Clocks	Flag		
				Note 1	Note 2		Z	AC	CY
8-bit operation	OR	A, #byte	2	1	–	$A \leftarrow A \vee \text{byte}$		x	
		saddr, #byte	3	2	–	$(\text{saddr}) \leftarrow (\text{saddr}) \vee \text{byte}$		x	
		A, r <sup>Note 3</sup>	2	1	–	$A \leftarrow A \vee r$		x	
		r, A	2	1	–	$r \leftarrow r \vee A$		x	
		A, laddr16	3	1	4	$A \leftarrow A \vee (\text{addr}16)$		x	
		A, ES:!addr16	4	2	5	$A \leftarrow A \vee (\text{ES:addr}16)$		x	
		A, saddr	2	1	–	$A \leftarrow A \vee (\text{saddr})$		x	
		A, [HL]	1	1	4	$A \leftarrow A \vee (\text{H})$		x	
		A, ES:[HL]	2	2	5	$A \leftarrow A \vee (\text{ES:HL})$		x	
		A, [HL+byte]	2	1	4	$A \leftarrow A \vee (\text{HL}+\text{byte})$		x	
		A, ES:[HL+byte]	3	2	5	$A \leftarrow A \vee ((\text{ES:HL})+\text{byte})$		x	
		A, [HL+B]	2	1	4	$A \leftarrow A \vee (\text{HL}+\text{B})$		x	
		A, ES:[HL+B]	3	2	5	$A \leftarrow A \vee ((\text{ES:HL})+\text{B})$		x	
		A, [HL+C]	2	1	4	$A \leftarrow A \vee (\text{HL}+\text{C})$		x	
	A, ES:[HL+C]	3	2	5	$A \leftarrow A \vee ((\text{ES:HL})+\text{C})$		x		
	XOR	A, #byte	2	1	–	$A \leftarrow A \oplus \text{byte}$		x	
		saddr, #byte	3	2	–	$(\text{saddr}) \leftarrow (\text{saddr}) \oplus \text{byte}$		x	
		A, r <sup>Note 3</sup>	2	1	–	$A \leftarrow A \oplus r$		x	
		r, A	2	1	–	$r \leftarrow r \oplus A$		x	
		A, laddr16	3	1	4	$A \leftarrow A \oplus (\text{addr}16)$		x	
		A, ES:!addr16	4	2	5	$A \leftarrow A \oplus (\text{ES:addr}16)$		x	
		A, saddr	2	1	–	$A \leftarrow A \oplus (\text{saddr})$		x	
		A, [HL]	1	1	4	$A \leftarrow A \oplus (\text{HL})$		x	
		A, ES:[HL]	2	2	5	$A \leftarrow A \oplus (\text{ES:HL})$		x	
		A, [HL+byte]	2	1	4	$A \leftarrow A \oplus (\text{HL}+\text{byte})$		x	
		A, ES:[HL+byte]	3	2	5	$A \leftarrow A \oplus ((\text{ES:HL})+\text{byte})$		x	
		A, [HL+B]	2	1	4	$A \leftarrow A \oplus (\text{HL}+\text{B})$		x	
		A, ES:[HL+B]	3	2	5	$A \leftarrow A \oplus ((\text{ES:HL})+\text{B})$		x	
A, [HL+C]		2	1	4	$A \leftarrow A \oplus (\text{HL}+\text{C})$		x		
A, ES:[HL+C]	3	2	5	$A \leftarrow A \oplus ((\text{ES:HL})+\text{C})$		x			

**Notes 1.** Number of CPU clocks ( $f_{\text{CLK}}$ ) when the internal RAM area, SFR area, or extended SFR area is accessed, or when no data is accessed.

**2.** Number of CPU clocks ( $f_{\text{CLK}}$ ) when the program memory area is accessed.

**3.** Except  $r = A$

**Remark** Number of clock is when program exists in the internal ROM (flash memory) area. If fetching the instruction from the internal RAM area, the number becomes double number plus 3 clocks at a maximum.

Table 28-5. Operation List (10/17)

Instruction Group	Mnemonic	Operands	Bytes	Clocks		Clocks	Flag		
				Note 1	Note 2		Z	AC	CY
8-bit operation	CMP	A, #byte	2	1	–	A – byte	x	x	x
		laddr16, #byte	4	1	4	(addr16) – byte	x	x	x
		ES:laddr16, #byte	5	2	5	(ES:addr16) – byte	x	x	x
		saddr, #byte	3	1	–	(saddr) – byte	x	x	x
		A, r <sup>Note3</sup>	2	1	–	A – r	x	x	x
		r, A	2	1	–	r – A	x	x	x
		A, laddr16	3	1	4	A – (addr16)	x	x	x
		A, ES:laddr16	4	2	5	A – (ES:addr16)	x	x	x
		A, saddr	2	1	–	A – (saddr)	x	x	x
		A, [HL]	1	1	4	A – (HL)	x	x	x
		A, ES:[HL]	2	2	5	A – (ES:HL)	x	x	x
		A, [HL+byte]	2	1	4	A – (HL+byte)	x	x	x
		A, ES:[HL+byte]	3	2	5	A – ((ES:HL)+byte)	x	x	x
		A, [HL+B]	2	1	4	A – (HL+B)	x	x	x
		A, ES:[HL+B]	3	2	5	A – ((ES:HL)+B)	x	x	x
		A, [HL+C]	2	1	4	A – (HL+C)	x	x	x
	A, ES:[HL+C]	3	2	5	A – ((ES:HL)+C)	x	x	x	
	CMP0	A	1	1	–	A – 00H	x	x	x
		X	1	1	–	X – 00H	x	x	x
		B	1	1	–	B – 00H	x	x	x
		C	1	1	–	C – 00H	x	x	x
		laddr16	3	1	4	(addr16) – 00H	x	x	x
		ES:laddr16	4	2	5	(ES:addr16) – 00H	x	x	x
		saddr	2	1	–	(saddr) – 00H	x	x	x
	CMPS	X, [HL+byte]	3	1	4	X – (HL+byte)	x	x	x
		X, ES:[HL+byte]	4	2	5	X – ((ES:HL)+byte)	x	x	x

- Notes**
1. Number of CPU clocks ( $f_{CLK}$ ) when the internal RAM area, SFR area, or extended SFR area is accessed, or when no data is accessed.
  2. Number of CPU clocks ( $f_{CLK}$ ) when the program memory area is accessed.
  3. Except  $r = A$

**Remark** Number of clock is when program exists in the internal ROM (flash memory) area. If fetching the instruction from the internal RAM area, the number becomes double number plus 3 clocks at a maximum.

Table 28-5. Operation List (11/17)

Instruction Group	Mnemonic	Operands	Bytes	Clocks		Clocks	Flag		
				Note 1	Note 2		Z	AC	CY
16-bit operation	ADDW	AX, #word	3	1	–	AX, CY ← AX+word	x	x	x
		AX, AX	1	1	–	AX, CY ← AX+AX	x	x	x
		AX, BC	1	1	–	AX, CY ← AX+BC	x	x	x
		AX, DE	1	1	–	AX, CY ← AX+DE	x	x	x
		AX, HL	1	1	–	AX, CY ← AX+HL	x	x	x
		AX, !addr16	3	1	4	AX, CY ← AX+(addr16)	x	x	x
		AX, ES:!addr16	4	2	5	AX, CY ← AX+(ES:addr16)	x	x	x
		AX, saddrp	2	1	–	AX, CY ← AX+(saddrp)	x	x	x
		AX, [HL+byte]	3	1	4	AX, CY ← AX+(HL+byte)	x	x	x
		AX, ES: [HL+byte]	4	2	5	AX, CY ← AX+((ES:HL)+byte)	x	x	x
	SUBW	AX, #word	3	1	–	AX, CY ← AX – word	x	x	x
		AX, BC	1	1	–	AX, CY ← AX – BC	x	x	x
		AX, DE	1	1	–	AX, CY ← AX – DE	x	x	x
		AX, HL	1	1	–	AX, CY ← AX – HL	x	x	x
		AX, !addr16	3	1	4	AX, CY ← AX – (addr16)	x	x	x
		AX, ES:!addr16	4	2	5	AX, CY ← AX – (ES:addr16)	x	x	x
		AX, saddrp	2	1	–	AX, CY ← AX – (saddrp)	x	x	x
		AX, [HL+byte]	3	1	4	AX, CY ← AX – (HL+byte)	x	x	x
		AX, ES: [HL+byte]	4	2	5	AX, CY ← AX – ((ES:HL)+byte)	x	x	x
		CMPW	AX, #word	3	1	–	AX – word	x	x
	AX, BC		1	1	–	AX – BC	x	x	x
	AX, DE		1	1	–	AX – DE	x	x	x
	AX, HL		1	1	–	AX – HL	x	x	x
	AX, !addr16		3	1	4	AX – (addr16)	x	x	x
	AX, ES:!addr16		4	2	5	AX – (ES:addr16)	x	x	x
	AX, saddrp		2	1	–	AX – (saddrp)	x	x	x
	AX, [HL+byte]		3	1	4	AX – (HL+byte)	x	x	x
AX, ES: [HL+byte]	4		2	5	AX – ((ES:HL)+byte)	x	x	x	
Multiply	MULU	X	1	1	–	AX ← A×X			

**Notes 1.** Number of CPU clocks ( $f_{CLK}$ ) when the internal RAM area, SFR area, or extended SFR area is accessed, or when no data is accessed.

**2.** Number of CPU clocks ( $f_{CLK}$ ) when the program memory area is accessed.

**Remark** Number of clock is when program exists in the internal ROM (flash memory) area. If fetching the instruction from the internal RAM area, the number becomes double number plus 3 clocks at a maximum.

Table 28-5. Operation List (12/17)

Instruction Group	Mnemonic	Operands	Bytes	Clocks		Clocks	Flag		
				Note 1	Note 2		Z	AC	CY
Increment/ decrement	INC	r	1	1	–	$r \leftarrow r+1$	x	x	
		laddr16	3	2	–	$(addr16) \leftarrow (addr16)+1$	x	x	
		ES:laddr16	4	3	–	$(ES, addr16) \leftarrow (ES, addr16)+1$	x	x	
		saddr	2	2	–	$(saddr) \leftarrow (saddr)+1$	x	x	
		[HL+byte]	3	2	–	$(HL+byte) \leftarrow (HL+byte)+1$	x	x	
		ES: [HL+byte]	4	3	–	$((ES:HL)+byte) \leftarrow ((ES:HL)+byte)+1$	x	x	
	DEC	r	1	1	–	$r \leftarrow r-1$	x	x	
		laddr16	3	2	–	$(addr16) \leftarrow (addr16)-1$	x	x	
		ES:laddr16	4	3	–	$(ES, addr16) \leftarrow (ES, addr16)-1$	x	x	
		saddr	2	2	–	$(saddr) \leftarrow (saddr)-1$	x	x	
		[HL+byte]	3	2	–	$(HL+byte) \leftarrow (HL+byte)-1$	x	x	
		ES: [HL+byte]	4	3	–	$((ES:HL)+byte) \leftarrow ((ES:HL)+byte)-1$	x	x	
	INCW	rp	1	1	–	$rp \leftarrow rp+1$			
		laddr16	3	2	–	$(addr16) \leftarrow (addr16)+1$			
		ES:laddr16	4	3	–	$(ES, addr16) \leftarrow (ES, addr16)+1$			
		saddrp	2	2	–	$(saddrp) \leftarrow (saddrp)+1$			
		[HL+byte]	3	2	–	$(HL+byte) \leftarrow (HL+byte)+1$			
		ES: [HL+byte]	4	3	–	$((ES:HL)+byte) \leftarrow ((ES:HL)+byte)+1$			
	DECW	rp	1	1	–	$rp \leftarrow rp-1$			
		laddr16	3	2	–	$(addr16) \leftarrow (addr16)-1$			
		ES:laddr16	4	3	–	$(ES, addr16) \leftarrow (ES, addr16)-1$			
saddrp		2	2	–	$(saddrp) \leftarrow (saddrp)-1$				
[HL+byte]		3	2	–	$(HL+byte) \leftarrow (HL+byte)-1$				
ES: [HL+byte]		4	3	–	$((ES:HL)+byte) \leftarrow ((ES:HL)+byte)-1$				
Shift	SHR	A, cnt	2	1	–	$(CY \leftarrow A_0, A_{m-1} \leftarrow A_m, A_7 \leftarrow 0) \times cnt$			x
	SHRW	AX, cnt	2	1	–	$(CY \leftarrow AX_0, AX_{m-1} \leftarrow AX_m, AX_{15} \leftarrow 0) \times cnt$			x
	SHL	A, cnt	2	1	–	$(CY \leftarrow A_7, A_m \leftarrow A_{m-1}, A_0 \leftarrow 0) \times cnt$			x
		B, cnt	2	1	–	$(CY \leftarrow B_7, B_m \leftarrow B_{m-1}, B_0 \leftarrow 0) \times cnt$			x
		C, cnt	2	1	–	$(CY \leftarrow C_7, C_m \leftarrow C_{m-1}, C_0 \leftarrow 0) \times cnt$			x
	SHLW	AX, cnt	2	1	–	$(CY \leftarrow AX_{15}, AX_m \leftarrow AX_{m-1}, AX_0 \leftarrow 0) \times cnt$			x
		BC, cnt	2	1	–	$(CY \leftarrow BC_{15}, BC_m \leftarrow BC_{m-1}, BC_0 \leftarrow 0) \times cnt$			x
	SAR	A, cnt	2	1	–	$(CY \leftarrow A_0, A_{m-1} \leftarrow A_m, A_7 \leftarrow A_7) \times cnt$			x
SARW	AX, cnt	2	1	–	$(CY \leftarrow AX_0, AX_{m-1} \leftarrow AX_m, AX_{15} \leftarrow AX_{15}) \times cnt$			x	

**Notes 1.** Number of CPU clocks ( $f_{CLK}$ ) when the internal RAM area, SFR area, or extended SFR area is accessed, or when no data is accessed.

**2.** Number of CPU clocks ( $f_{CLK}$ ) when the program memory area is accessed.

**Remarks 1.** Number of clock is when program exists in the internal ROM (flash memory) area. If fetching the instruction from the internal RAM area, the number becomes double number plus 3 clocks at a maximum.

**2.** cnt indicates the bit shift count.



Table 28-5. Operation List (13/17)

Instruction Group	Mnemonic	Operands	Bytes	Clocks		Clocks	Flag		
				Note 1	Note 2		Z	AC	CY
Rotate	ROR	A, 1	2	1	–	$(CY, A_7 \leftarrow A_0, A_{m-1} \leftarrow A_m) \times 1$			x
	ROL	A, 1	2	1	–	$(CY, A_0 \leftarrow A_7, A_{m+1} \leftarrow A_m) \times 1$			x
	RORC	A, 1	2	1	–	$(CY \leftarrow A_0, A_7 \leftarrow CY, A_{m-1} \leftarrow A_m) \times 1$			x
	ROLC	A, 1	2	1	–	$(CY \leftarrow A_7, A_0 \leftarrow CY, A_{m+1} \leftarrow A_m) \times 1$			x
	ROLWC	AX,1	2	1	–	$(CY \leftarrow AX_{15}, AX_0 \leftarrow CY, AX_{m+1} \leftarrow AX_m) \times 1$			x
		BC,1	2	1	–	$(CY \leftarrow BC_{15}, BC_0 \leftarrow CY, BC_{m+1} \leftarrow BC_m) \times 1$			x
Bit manipulate	MOV1	CY, A.bit	2	1	–	$CY \leftarrow A.bit$			x
		A.bit, CY	2	1	–	$A.bit \leftarrow CY$			
		CY, PSW.bit	3	1	–	$CY \leftarrow PSW.bit$			x
		PSW.bit, CY	3	4	–	$PSW.bit \leftarrow CY$	x	x	
		CY, saddr.bit	3	1	–	$CY \leftarrow (saddr).bit$			x
		saddr.bit, CY	3	2	–	$(saddr).bit \leftarrow CY$			
		CY, sfr.bit	3	1	–	$CY \leftarrow sfr.bit$			x
		sfr.bit, CY	3	2	–	$sfr.bit \leftarrow CY$			
		CY,[HL].bit	2	1	4	$CY \leftarrow (HL).bit$			x
		[HL].bit, CY	2	2	–	$(HL).bit \leftarrow CY$			
	AND1	CY, ES:[HL].bit	3	2	5	$CY \leftarrow (ES, HL).bit$			x
		ES:[HL].bit, CY	3	3	–	$(ES, HL).bit \leftarrow CY$			
		CY, A.bit	2	1	–	$CY \leftarrow CY \wedge A.bit$			x
		CY, PSW.bit	3	1	–	$CY \leftarrow CY \wedge PSW.bit$			x
		CY, saddr.bit	3	1	–	$CY \leftarrow CY \wedge (saddr).bit$			x
		CY, sfr.bit	3	1	–	$CY \leftarrow CY \wedge sfr.bit$			x
	OR1	CY,[HL].bit	2	1	4	$CY \leftarrow CY \vee (HL).bit$			x
		CY, ES:[HL].bit	3	2	5	$CY \leftarrow CY \vee (ES, HL).bit$			x
		CY, A.bit	2	1	–	$CY \leftarrow CY \vee A.bit$			x
		CY, PSW.bit	3	1	–	$CY \leftarrow CY \vee PSW.bit$			x
		CY, saddr.bit	3	1	–	$CY \leftarrow CY \vee (saddr).bit$			x
		CY, sfr.bit	3	1	–	$CY \leftarrow CY \vee sfr.bit$			x

**Notes 1.** Number of CPU clocks ( $f_{CLK}$ ) when the internal RAM area, SFR area, or extended SFR area is accessed, or when no data is accessed.

**2.** Number of CPU clocks ( $f_{CLK}$ ) when the program memory area is accessed.

**Remark** Number of clock is when program exists in the internal ROM (flash memory) area. If fetching the instruction from the internal RAM area, the number becomes double number plus 3 clocks at a maximum.

Table 28-5. Operation List (14/17)

Instruction Group	Mnemonic	Operands	Bytes	Clocks		Clocks	Flag		
				Note 1	Note 2		Z	AC	CY
Bit manipulate	XOR1	CY, A.bit	2	1	–	$CY \leftarrow CY \nabla A.bit$			x
		CY, PSW.bit	3	1	–	$CY \leftarrow CY \nabla PSW.bit$			x
		CY, saddr.bit	3	1	–	$CY \leftarrow CY \nabla (saddr).bit$			x
		CY, sfr.bit	3	1	–	$CY \leftarrow CY \nabla sfr.bit$			x
		CY, [HL].bit	2	1	4	$CY \leftarrow CY \nabla (HL).bit$			x
		CY, ES:[HL].bit	3	2	5	$CY \leftarrow CY \nabla (ES, HL).bit$			x
	SET1	A.bit	2	1	–	$A.bit \leftarrow 1$			
		PSW.bit	3	4	–	$PSW.bit \leftarrow 1$	x	x	x
		!addr16.bit	4	2	–	$(addr16).bit \leftarrow 1$			
		ES:!addr16.bit	5	3	–	$(ES, addr16).bit \leftarrow 1$			
		saddr.bit	3	2	–	$(saddr).bit \leftarrow 1$			
		sfr.bit	3	2	–	$sfr.bit \leftarrow 1$			
		[HL].bit	2	2	–	$(HL).bit \leftarrow 1$			
		ES:[HL].bit	3	3	–	$(ES, HL).bit \leftarrow 1$			
	CLR1	A.bit	2	1	–	$A.bit \leftarrow 0$			
		PSW.bit	3	4	–	$PSW.bit \leftarrow 0$	x	x	x
		!addr16.bit	4	2	–	$(addr16).bit \leftarrow 0$			
		ES:!addr16.bit	5	3	–	$(ES, addr16).bit \leftarrow 0$			
		saddr.bit	3	2	–	$(saddr).bit \leftarrow 0$			
		sfr.bit	3	2	–	$sfr.bit \leftarrow 0$			
		[HL].bit	2	2	–	$(HL).bit \leftarrow 0$			
		ES:[HL].bit	3	3	–	$(ES, HL).bit \leftarrow 0$			
	SET1	CY	2	1	–	$CY \leftarrow 1$			1
	CLR1	CY	2	1	–	$CY \leftarrow 0$			0
	NOT1	CY	2	1	–	$CY \leftarrow \neg CY$			x

**Notes 1.** Number of CPU clocks ( $f_{CLK}$ ) when the internal RAM area, SFR area, or extended SFR area is accessed, or when no data is accessed

**2.** Number of CPU clocks ( $f_{CLK}$ ) when the program memory area is accessed.

**Remark** Number of clock is when program exists in the internal ROM (flash memory) area. If fetching the instruction from the internal RAM area, the number becomes double number plus 3 clocks at a maximum.

Table 28-5. Operation List (15/17)

Instruction Group	Mnemonic	Operands	Bytes	Clocks		Clocks	Flag		
				Note 1	Note 2		Z	AC	CY
Call/ return	CALL	rp	2	3	–	(SP – 2) ← (PC+2) <sub>s</sub> , (SP – 3) ← (PC+2) <sub>H</sub> , (SP – 4) ← (PC+2) <sub>L</sub> , PC ← CS, rp, SP ← SP – 4			
		\$!addr20	3	3	–	(SP – 2) ← (PC+3) <sub>s</sub> , (SP – 3) ← (PC+3) <sub>H</sub> , (SP – 4) ← (PC+3) <sub>L</sub> , PC ← PC+3+jdisp16, SP ← SP – 4			
		laddr16	3	3	–	(SP – 2) ← (PC+3) <sub>s</sub> , (SP – 3) ← (PC+3) <sub>H</sub> , (SP – 4) ← (PC+3) <sub>L</sub> , PC ← 0000, addr16, SP ← SP – 4			
		!!addr20	4	3	–	(SP – 2) ← (PC+4) <sub>s</sub> , (SP – 3) ← (PC+4) <sub>H</sub> , (SP – 4) ← (PC+4) <sub>L</sub> , PC ← addr20, SP ← SP – 4			
	CALLT	[addr5]	2	5	–	(SP – 2) ← (PC+2) <sub>s</sub> , (SP – 3) ← (PC+2) <sub>H</sub> , (SP – 4) ← (PC+2) <sub>L</sub> , PC <sub>s</sub> ← 0000, PC <sub>H</sub> ← (0000, addr5+1), PC <sub>L</sub> ← (0000, addr5), SP ← SP – 4			
	BRK	-	2	5	–	(SP – 1) ← PSW, (SP – 2) ← (PC+2) <sub>s</sub> , (SP – 3) ← (PC+2) <sub>H</sub> , (SP – 4) ← (PC+2) <sub>L</sub> , PC <sub>s</sub> ← 0000, PC <sub>H</sub> ← (0007FH), PC <sub>L</sub> ← (0007EH), SP ← SP – 4, IE ← 0			
	RET	-	1	6	–	PC <sub>L</sub> ← (SP), PC <sub>H</sub> ← (SP+1), PC <sub>s</sub> ← (SP+2), SP ← SP+4			
RETI	-	2	6	–	PC <sub>L</sub> ← (SP), PC <sub>H</sub> ← (SP+1), PC <sub>s</sub> ← (SP+2), PSW ← (SP+3), SP ← SP+4	R	R	R	
RETB	-	2	6	–	PC <sub>L</sub> ← (SP), PC <sub>H</sub> ← (SP+1), PC <sub>s</sub> ← (SP+2), PSW ← (SP+3), SP ← SP+4	R	R	R	

- Notes 1.** Number of CPU clocks ( $f_{CLK}$ ) when the internal RAM area, SFR area, or extended SFR area is accessed, or when no data is accessed.
- 2.** Number of CPU clocks ( $f_{CLK}$ ) when the program memory area is accessed.

**Remark** Number of clock is when program exists in the internal ROM (flash memory) area. If fetching the instruction from the internal RAM area, the number becomes double number plus 3 clocks at a maximum.

Table 28-5. Operation List (16/17)

Instruction Group	Mnemonic	Operands	Bytes	Clocks		Clocks	Flag		
				Note 1	Note 2		Z	AC	CY
Stack manipulate	PUSH	PSW	2	1	–	(SP – 1) ← PSW, (SP – 2) ← 00H, SP ← SP – 2			
		rp	1	1	–	(SP – 1) ← rp <sub>H</sub> , (SP – 2) ← rp <sub>L</sub> , SP ← SP – 2			
	POP	PSW	2	3	–	PSW ← (SP+1), SP ← SP + 2	R	R	R
		rp	1	1	–	rp <sub>L</sub> ← (SP), rp <sub>H</sub> ← (SP+1), SP ← SP + 2			
	MOVW	SP, #word	4	1	–	SP ← word			
		SP, AX	2	1	–	SP ← AX			
		AX, SP	2	1	–	AX ← SP			
		HL, SP	3	1	–	HL ← SP			
		BC, SP	3	1	–	BC ← SP			
		DE, SP	3	1	–	DE ← SP			
ADDW	SP, #byte	2	1	–	SP ← SP + byte				
SUBW	SP, #byte	2	1	–	SP ← SP – byte				
Unconditional branch	BR	AX	2	3	–	PC ← CS, AX			
		\$addr20	2	3	–	PC ← PC + 2 + jdisp8			
		!addr20	3	3	–	PC ← PC + 3 + jdisp16			
		laddr16	3	3	–	PC ← 0000, addr16			
		!!addr20	4	3	–	PC ← addr20			
Conditional branch	BC	\$addr20	2	2/4 <sup>Note3</sup>	–	PC ← PC + 2 + jdisp8 if CY = 1			
	BNC	\$addr20	2	2/4 <sup>Note3</sup>	–	PC ← PC + 2 + jdisp8 if CY = 0			
	BZ	\$addr20	2	2/4 <sup>Note3</sup>	–	PC ← PC + 2 + jdisp8 if Z = 1			
	BNZ	\$addr20	2	2/4 <sup>Note3</sup>	–	PC ← PC + 2 + jdisp8 if Z = 0			
	BH	\$addr20	3	2/4 <sup>Note3</sup>	–	PC ← PC + 3 + jdisp8 if (Z∨CY)=0			
	BNH	\$addr20	3	2/4 <sup>Note3</sup>	–	PC ← PC + 3 + jdisp8 if (Z∨CY)=1			
	BT	saddr.bit, \$addr20	4	3/5 <sup>Note3</sup>	–	PC ← PC + 4 + jdisp8 if (saddr).bit = 1			
		sfr.bit, \$addr20	4	3/5 <sup>Note3</sup>	–	PC ← PC + 4 + jdisp8 if sfr.bit = 1			
		A.bit, \$addr20	3	3/5 <sup>Note3</sup>	–	PC ← PC + 3 + jdisp8 if A.bit = 1			
		PSW.bit, \$addr20	4	3/5 <sup>Note3</sup>	–	PC ← PC + 4 + jdisp8 if PSW.bit = 1			
		[HL].bit, \$addr20	3	3/5 <sup>Note3</sup>	6/7	PC ← PC + 3 + jdisp8 if (HL).bit = 1			
ES:[HL].bit, \$addr20	4	4/6 <sup>Note3</sup>	7/8	PC ← PC + 4 + jdisp8 if (ES, HL).bit = 1					

- Notes 1.** Number of CPU clocks ( $f_{CLK}$ ) when the internal RAM area, SFR area, or extended SFR area is accessed, or when no data is accessed.
- 2.** Number of CPU clocks ( $f_{CLK}$ ) when the program memory area is accessed.
- 3.** This indicates the number of clocks “when condition is not met/when condition is met”.

**Remark** Number of clock is when program exists in the internal ROM (flash memory) area. If fetching the instruction from the internal RAM area, the number becomes double number plus 3 clocks at a maximum.

Table 28-5. Operation List (17/17)

Instruction Group	Mnemonic	Operands	Bytes	Clocks		Clocks	Flag		
				Note 1	Note 2		Z	AC	CY
Conditional branch	BF	saddr.bit, \$addr20	4	3/5 <sup>Note3</sup>	–	PC ← PC + 4 + jdisp8 if (saddr).bit = 0			
		sfr.bit, \$addr20	4	3/5 <sup>Note3</sup>	–	PC ← PC + 4 + jdisp8 if sfr.bit = 0			
		A.bit, \$addr20	3	3/5 <sup>Note3</sup>	–	PC ← PC + 3 + jdisp8 if A.bit = 0			
		PSW.bit, \$addr20	4	3/5 <sup>Note3</sup>	–	PC ← PC + 4 + jdisp8 if PSW.bit = 0			
		[HL].bit, \$addr20	3	3/5 <sup>Note3</sup>	6/7	PC ← PC + 3 + jdisp8 if (HL).bit = 0			
		ES:[HL].bit, \$addr20	4	4/6 <sup>Note3</sup>	7/8	PC ← PC + 4 + jdisp8 if (ES, HL).bit = 0			
	BTCLR	saddr.bit, \$addr20	4	3/5 <sup>Note3</sup>	–	PC ← PC + 4 + jdisp8 if (saddr).bit = 1 then reset (saddr).bit			
		sfr.bit, \$addr20	4	3/5 <sup>Note3</sup>	–	PC ← PC + 4 + jdisp8 if sfr.bit = 1 then reset sfr.bit			
		A.bit, \$addr20	3	3/5 <sup>Note3</sup>	–	PC ← PC + 3 + jdisp8 if A.bit = 1 then reset A.bit			
		PSW.bit, \$addr20	4	3/5 <sup>Note3</sup>	–	PC ← PC + 4 + jdisp8 if PSW.bit = 1 then reset PSW.bit	×	×	×
		[HL].bit, \$addr20	3	3/5 <sup>Note3</sup>	–	PC ← PC + 3 + jdisp8 if (HL).bit = 1 then reset (HL).bit			
		ES:[HL].bit, \$addr20	4	4/6 <sup>Note3</sup>	–	PC ← PC + 4 + jdisp8 if (ES, HL).bit = 1 then reset (ES, HL).bit			
Conditional skip	SKC	–	2	1	–	Next instruction skip if CY = 1			
	SKNC	–	2	1	–	Next instruction skip if CY = 0			
	SKZ	–	2	1	–	Next instruction skip if Z = 1			
	SKNZ	–	2	1	–	Next instruction skip if Z = 0			
	SKH	–	2	1	–	Next instruction skip if (Z∨CY)=0			
	SKNH	–	2	1	–	Next instruction skip if (Z∨CY)=1			
CPU control	SEL <sup>Note4</sup>	Rb <sub>n</sub>	2	1	–	RBS[1:0] ← n			
	NOP	–	1	1	–	No Operation			
	EI	–	3	4	–	IE ← 1 (Enable Interrupt)			
	DI	–	3	4	–	IE ← 0 (Disable Interrupt)			
	HALT	–	2	3	–	Set HALT Mode			
	STOP	–	2	3	–	Set STOP Mode			

- Notes 1.** Number of CPU clocks ( $f_{CLK}$ ) when the internal RAM area, SFR area, or extended SFR area is accessed, or when no data is accessed.
- 2.** Number of CPU clocks ( $f_{CLK}$ ) when the program memory area is accessed.
- 3.** This indicates the number of clocks “when condition is not met/when condition is met”.

**Remark** Number of clock is when program exists in the internal ROM (flash memory) area. If fetching the instruction from the internal RAM area, the number becomes double number plus 3 clocks at a maximum.

&lt;R&gt;

**CHAPTER 29 ELECTRICAL SPECIFICATIONS**

- Cautions**
- 1. The RL78/G13 have an on-chip debug function, which is provided for development and evaluation. Do not use the on-chip debug function in products designated for mass production, because the guaranteed number of rewritable times of the flash memory may be exceeded when this function is used, and product reliability therefore cannot be guaranteed. Renesas Electronics is not liable for problems occurring when the on-chip debug function is used.**
  - 2. The pins mounted are as follows according to product.**

**29.1 Pins Mounted According to Product****29.1.1 Port functions**

Refer to **2.1.1 20-pin products** to **2.1.14 128-pin products**.

**29.1.2 Non-port functions**

Refer to **2.1.15 Pins for each product (pins other than port pins)**.

**Caution** The pins mounted depend on the product. Refer to 2.1.1 20-pin products to 2.1.14 128-pin products, and 2.1.15 Pins for each product (pins other than port pins).

## <R> 29.2 Absolute Maximum Ratings

### Absolute Maximum Ratings (T<sub>A</sub> = 25°C) (1/2)

Parameter	Symbols	Conditions	Ratings	Unit
Supply voltage	V <sub>DD</sub>		-0.5 to +6.5	V
	EV <sub>DD0</sub> , EV <sub>DD1</sub>	EV <sub>DD0</sub> = EV <sub>DD1</sub>	-0.5 to +6.5	V
	V <sub>SS</sub>		-0.5 to +0.3	V
	EV <sub>SS0</sub> , EV <sub>SS1</sub>	EV <sub>SS0</sub> = EV <sub>SS1</sub>	-0.5 to +0.3	V
REGC pin input voltage	V <sub>REGC</sub>	REGC	-0.3 to +2.8 and -0.3 to V <sub>DD</sub> +0.3 <sup>Note 1</sup>	V
Input voltage	V <sub>I1</sub>	P00 to P07, P10 to P17, P30 to P37, P40 to P47, P50 to P57, P64 to P67, P70 to P77, P80 to P87, P90 to P97, P100 to P106, P110 to P117, P120, P125 to P127, P140 to P147	-0.3 to EV <sub>DD0</sub> +0.3 and -0.3 to V <sub>DD</sub> +0.3 <sup>Note 2</sup>	V
	V <sub>I2</sub>	P60 to P63 (N-ch open-drain)	-0.3 to +6.5	V
	V <sub>I3</sub>	P20 to P27, P121 to P124, P137, P150 to P156, EXCLK, EXCLKS, RESET	-0.3 to V <sub>DD</sub> +0.3 <sup>Note 2</sup>	V
Output voltage	V <sub>O1</sub>	P00 to P07, P10 to P17, P30 to P37, P40 to P47, P50 to P57, P60 to P67, P70 to P77, P80 to P87, P90 to P97, P100 to P106, P110 to P117, P120, P125 to P127, P130, P140 to P147	-0.3 to EV <sub>DD0</sub> +0.3 and -0.3 to V <sub>DD</sub> +0.3 <sup>Note 2</sup>	V
	V <sub>O2</sub>	P20 to P27, P150 to P156	-0.3 to V <sub>DD</sub> +0.3 <sup>Note 2</sup>	V
Analog input voltage	V <sub>AI1</sub>	ANI16 to ANI26	-0.3 to EV <sub>DD0</sub> +0.3 <sup>Note 2</sup>	V
	V <sub>AI2</sub>	ANI0 to ANI14	-0.3 to V <sub>DD</sub> +0.3 <sup>Note 2</sup>	V

- Notes**
1. Connect the REGC pin to V<sub>SS</sub> via a capacitor (0.47 to 1 μF). This value regulates the absolute maximum rating of the REGC pin. Do not use this pin with voltage applied to it.
  2. Must be 6.5 V or lower.

**Caution** Product quality may suffer if the absolute maximum rating is exceeded even momentarily for any parameter. That is, the absolute maximum ratings are rated values at which the product is on the verge of suffering physical damage, and therefore the product must be used under conditions that ensure that the absolute maximum ratings are not exceeded.

**Remark** Unless specified otherwise, the characteristics of alternate-function pins are the same as those of the port pins.

**Caution** The pins mounted depend on the product. Refer to 2.1.1 20-pin products to 2.1.14 128-pin products, and 2.1.15 Pins for each product (pins other than port pins).

**Absolute Maximum Ratings (TA = 25°C) (2/2)**

Parameter	Symbols	Conditions		Ratings	Unit
Output current, high	I <sub>OH1</sub>	Per pin	P00 to P07, P10 to P17, P30 to P37, P40 to P47, P50 to P57, P64 to P67, P70 to P77, P80 to P87, P90 to P97, P100 to P106, P110 to P117, P120, P125 to P127, P130, P140 to P147	-40	mA
		Total of all pins -170 mA	P00 to P04, P07, P32 to P37, P40 to P47, P102 to P106, P120, P125 to P127, P130, P140 to P145	-70	mA
			P05, P06, P10 to P17, P30, P31, P50 to P57, P64 to P67, P70 to P77, P80 to P87, P90 to P97, P100, P101, P110 to P117, P146, P147	-100	mA
	I <sub>OH2</sub>	Per pin	P20 to P27, P150 to P156	-0.5	mA
		Total of all pins		-2	mA
Output current, low	I <sub>OL1</sub>	Per pin	P00 to P07, P10 to P17, P30 to P37, P40 to P47, P50 to P57, P60 to P67, P70 to P77, P80 to P87, P90 to P97, P100 to P106, P110 to P117, P120, P125 to P127, P130, P140 to P147	40	mA
		Total of all pins 170 mA	P00 to P04, P07, P32 to P37, P40 to P47, P102 to P106, P120, P125 to p127, P130, P140 to P145	70	mA
			P05, P06, P10 to P17, P30, P31, P50 to P57, P64 to P67, P70 to P77, P80 to P87, P90 to P97, P100, P101, P110 to P117, P146, P147	100	mA
	I <sub>OL2</sub>	Per pin	P20 to P27, P150 to P156	1	mA
		Total of all pins		5	mA
Operating ambient temperature	T <sub>A</sub>	In normal operation mode		-40 to +85	°C
		In flash memory programming mode			
Storage temperature	T <sub>stg</sub>			-65 to +150	°C

**Caution** Product quality may suffer if the absolute maximum rating is exceeded even momentarily for any parameter. That is, the absolute maximum ratings are rated values at which the product is on the verge of suffering physical damage, and therefore the product must be used under conditions that ensure that the absolute maximum ratings are not exceeded.

**Remark** Unless specified otherwise, the characteristics of alternate-function pins are the same as those of the port pins.



**Caution** The pins mounted depend on the product. Refer to 2.1.1 20-pin products to 2.1.14 128-pin products, and 2.1.15 Pins for each product (pins other than port pins).

### 29.3 Oscillator Characteristics

#### 29.3.1 Main system clock oscillator characteristics

( $T_A = -40$  to  $+85^\circ\text{C}$ ,  $1.6\text{ V} \leq EV_{DD0} = EV_{DD1} \leq V_{DD} \leq 5.5\text{ V}$ ,  $V_{SS} = EV_{SS0} = EV_{SS1} = 0\text{ V}$ )

Resonator	Recommended Circuit	Parameter	Conditions	MIN.	TYP.	MAX.	Unit
Ceramic resonator		X1 clock oscillation frequency ( $f_x$ ) <sup>Note</sup>	$2.7\text{ V} \leq V_{DD} \leq 5.5\text{ V}$	1.0		20.0	MHz
			$1.8\text{ V} \leq V_{DD} < 2.7\text{ V}$	1.0		8.0	MHz
			$1.6\text{ V} \leq V_{DD} < 1.8\text{ V}$	1.0		4.0	MHz
Crystal resonator		X1 clock oscillation frequency ( $f_x$ ) <sup>Note</sup>	$2.7\text{ V} \leq V_{DD} \leq 5.5\text{ V}$	1.0		20.0	MHz
			$1.8\text{ V} \leq V_{DD} < 2.7\text{ V}$	1.0		8.0	MHz
			$1.6\text{ V} \leq V_{DD} < 1.8\text{ V}$	1.0		4.0	MHz

**Note** Indicates only oscillator characteristics. Refer to AC Characteristics for instruction execution time.

**Cautions** 1. When using the X1 oscillator, wire as follows in the area enclosed by the broken lines in the above figures to avoid an adverse effect from wiring capacitance.

- Keep the wiring length as short as possible.
  - Do not cross the wiring with the other signal lines.
  - Do not route the wiring near a signal line through which a high fluctuating current flows.
  - Always make the ground point of the oscillator capacitor the same potential as V<sub>SS</sub>.
  - Do not ground the capacitor to a ground pattern through which a high current flows.
  - Do not fetch signals from the oscillator.
2. Since the CPU is started by the high-speed on-chip oscillator clock after a reset release, check the X1 clock oscillation stabilization time using the oscillation stabilization time counter status register (OSTC) by the user. Determine the oscillation stabilization time of the OSTC register and the oscillation stabilization time select register (OSTS) after sufficiently evaluating the oscillation stabilization time with the resonator to be used.

**Caution** The pins mounted depend on the product. Refer to 2.1.1 20-pin products to 2.1.14 128-pin products, and 2.1.15 Pins for each product (pins other than port pins).

<R> 29.3.2 On-chip oscillator characteristics

( $T_A = -20$  to  $+85^\circ\text{C}$ ,  $1.6\text{ V} \leq EV_{DD0} = EV_{DD1} \leq V_{DD} \leq 5.5\text{ V}$ ,  $V_{SS} = EV_{SS0} = EV_{SS1} = 0\text{ V}$ )

Oscillators	Parameters	Conditions	MIN.	TYP.	MAX.	Unit	
High-speed on-chip oscillator clock frequency <sup>Note</sup>	$f_{IH}$	$1.8\text{ V} \leq V_{DD} \leq 5.5\text{ V}$	32 MHz selected	31.68	32.00	32.32	MHz
			24 MHz selected	23.76	24.00	24.24	MHz
			16 MHz selected	15.84	16.00	16.16	MHz
			12 MHz selected	11.88	12.00	12.12	MHz
			8 MHz selected	7.92	8.00	8.08	MHz
			4 MHz selected	3.96	4.00	4.04	MHz
			1 MHz selected	0.99	1.00	1.01	MHz
		$1.6\text{ V} \leq V_{DD} < 1.8\text{ V}$	32 MHz selected	30.40	32.00	33.60	MHz
			24 MHz selected	22.80	24.00	25.20	MHz
			16 MHz selected	15.20	16.00	16.80	MHz
			12 MHz selected	11.40	12.00	12.60	MHz
			8 MHz selected	7.60	8.00	8.40	MHz
			4 MHz selected	3.80	4.00	4.20	MHz
			1 MHz selected	0.95	1.00	1.05	MHz
Low-speed on-chip oscillator clock frequency	$f_{IL}$		12.75	15	17.25	kHz	

( $T_A = -40$  to  $+85^\circ\text{C}$ ,  $1.6\text{ V} \leq EV_{DD0} = EV_{DD1} \leq V_{DD} \leq 5.5\text{ V}$ ,  $V_{SS} = EV_{SS0} = EV_{SS1} = 0\text{ V}$ )

Oscillators	Parameters	Conditions	MIN.	TYP.	MAX.	Unit	
High-speed on-chip oscillator clock frequency <sup>Note</sup>	$f_{IH}$	$1.8\text{ V} \leq V_{DD} \leq 5.5\text{ V}$	32 MHz selected	31.52	32.00	32.48	MHz
			24 MHz selected	23.64	24.00	24.36	MHz
			16 MHz selected	15.76	16.00	16.24	MHz
			12 MHz selected	11.82	12.00	12.18	MHz
			8 MHz selected	7.88	8.00	8.12	MHz
			4 MHz selected	3.94	4.00	4.06	MHz
			1 MHz selected	0.985	1.00	1.015	MHz
		$1.6\text{ V} \leq V_{DD} < 1.8\text{ V}$	32 MHz selected	30.24	32.00	33.76	MHz
			24 MHz selected	22.68	24.00	25.32	MHz
			16 MHz selected	15.12	16.00	16.88	MHz
			12 MHz selected	11.34	12.00	12.66	MHz
			8 MHz selected	7.56	8.00	8.44	MHz
			4 MHz selected	3.78	4.00	4.22	MHz
			1 MHz selected	0.945	1.00	1.055	MHz
Low-speed on-chip oscillator clock frequency	$f_{IL}$		12.75	15	17.25	kHz	

**Note** This only indicates the oscillator characteristics. Refer to AC Characteristics for instruction execution time. When WQFN (24-, 32-, 40-, 48-pin), FLGA (25-, 36-pin), FBGA (64-pin), TQFP (64-pin), LQFP (14 × 20) (100-, 128-pin) products, these specifications show target values, which may change after device evaluation.

**Caution** The pins mounted depend on the product. Refer to 2.1.1 20-pin products to 2.1.14 128-pin products, and 2.1.15 Pins for each product (pins other than port pins).

### 29.3.3 Subsystem clock oscillator characteristics

( $T_A = -40$  to  $+85^\circ\text{C}$ ,  $1.6\text{ V} \leq EV_{DD0} = EV_{DD1} \leq V_{DD} \leq 5.5\text{ V}$ ,  $V_{SS} = EV_{SS0} = EV_{SS1} = 0\text{ V}$ )

Resonator	Recommended Circuit	Items	Conditions	MIN.	TYP.	MAX.	Unit
Crystal resonator		XT1 clock oscillation frequency ( $f_{XT1}$ ) <sup>Note</sup>		32	32.768	35	kHz

**Note** Indicates only oscillator characteristics. Refer to AC Characteristics for instruction execution time.

**Cautions 1.** When using the XT1 oscillator, wire as follows in the area enclosed by the broken lines in the above figures to avoid an adverse effect from wiring capacitance.

- Keep the wiring length as short as possible.
  - Do not cross the wiring with the other signal lines.
  - Do not route the wiring near a signal line through which a high fluctuating current flows.
  - Always make the ground point of the oscillator capacitor the same potential as  $V_{SS}$ .
  - Do not ground the capacitor to a ground pattern through which a high current flows.
  - Do not fetch signals from the oscillator.
2. The XT1 oscillator is designed as a low-amplitude circuit for reducing power consumption, and is more prone to malfunction due to noise than the X1 oscillator. Particular care is therefore required with the wiring method when the XT1 clock is used.

**Caution** The pins mounted depend on the product. Refer to 2.1.1 20-pin products to 2.1.14 128-pin products, and 2.1.15 Pins for each product (pins other than port pins).

<R> 29.3.4 Recommended Oscillator Constants

(1) X1 oscillation: Ceramic resonator (AMPH = 0, T<sub>A</sub> = - 40 to +85°C)

Manufacturer	Part Number	SMD/Lead	Frequency (MHz)	Flash operation mode <sup>Note</sup>	Recommended Circuit Constants			Oscillation Voltage Range	
					C1 (pF)	C2 (pF)	Rd (kΩ)	MIN. (V)	MAX. (V)
Murata Manufacturing Co., Ltd.	CSBFB1M00J58-R1	SMD	1.0	HS, LV, LS	100	100	0	1.7	5.5
	CSBLA1M00J58-B0	Lead			100	100	0		
	CSTCC2M00G56-R0	SMD	2.0		Internal (47)	Internal (47)	0	1.6	5.5
	CSTCR4M00G55-R0	SMD			Internal (39)	Internal (39)	0		
	CSTLS4M00G53-B0	Lead			Internal (15)	Internal (15)	0		
	CSTCR4M19G55-R0	SMD	4.194	HS, LS	Internal (39)	Internal (39)	0	1.8	5.5
	CSTLS4M19G53-B0	Lead			Internal (15)	Internal (15)	0		
	CSTCR4M91G53-R0	SMD	4.915		Internal (15)	Internal (15)	0		
	CSTLS4M91G53-B0	Lead			Internal (15)	Internal (15)	0		
	CSTCR5M00G53-R0	SMD	5.0		Internal (15)	Internal (15)	0		
	CSTLS5M00G53-B0	Lead			Internal (15)	Internal (15)	0		
	CSTCR6M00G53-R0	SMD	6.0		Internal (15)	Internal (15)	0		
	CSTLS6M00G53-B0	Lead			Internal (15)	Internal (15)	0		
	CSTCE8M00G52-R0	SMD	8.0		Internal (10)	Internal (10)	0		
	CSTLS8M00G53-B0	Lead			Internal (15)	Internal (15)	0		
	CSTCE8M38G52-R0	SMD	8.388	HS	Internal (10)	Internal (10)	0	2.4	5.5
CSTLS8M38G53-B0	Lead	Internal (15)			Internal (15)	0			
CSTCE10M0G52-R0	SMD	10.0		Internal (10)	Internal (10)	0			
CSTLS10M0G53-B0	Lead			Internal (15)	Internal (15)	0			
TDK Corporation	CCR4.0MUC8	SMD	4.0	HS, LV, LS	Internal (27)	Internal (27)	0	1.6	5.5
	CCR8.0MXC8	SMD	8.0	HS, LS	Internal (18)	Internal (18)	0	1.8	5.5
	CCR10.0MXC8	SMD	10.0	HS	Internal (18)	Internal (18)	0	2.4	5.5

**Note** Set the flash operation mode by using CMODE1 and CMODE0 bits of the option byte (000C2H/010C2H).

**Caution** The oscillator constants shown above are reference values based on evaluation in a specific environment by the resonator manufacturer. If it is necessary to optimize the oscillator characteristics in the actual application, apply to the resonator manufacturer for evaluation on the implementation circuit. The oscillation voltage and oscillation frequency only indicate the oscillator characteristic. Use the RL78/G13 so that the internal operation conditions are within the specifications of the DC and AC characteristics.

**Remark** Values in parentheses in the C1, C2 columns indicate an internal capacitance.

**Caution** The pins mounted depend on the product. Refer to 2.1.1 20-pin products to 2.1.14 128-pin products, and 2.1.15 Pins for each product (pins other than port pins).

**(2) X1 oscillation: Ceramic resonator (AMPH = 1, T<sub>A</sub> = - 40 to +85° C)**

Manufacturer	Part Number	SMD/Lead	Frequency (MHz)	Flash operation mode <sup>Note</sup>	Recommended Circuit Constants			Oscillation Voltage Range	
					C1 (pF)	C2 (pF)	Rd (kΩ)	MIN. (V)	MAX. (V)
Murata Manufacturing Co., Ltd.	CSTCE12M0G52-R0	SMD	12.0	HS	Internal (10)	Internal (10)	0	2.4	5.5
	CSTCE16M0V53-R0	SMD	16.0		Internal (15)	Internal (15)	0		
	CSTLS16M0X51-B0	Lead			Internal (5)	Internal (5)	0		
	CSTCE20M0V51-R0	SMD	20.0		Internal (5)	Internal (5)	0		
	CSTLS20M0X51-B0	Lead			Internal (5)	Internal (5)	0		
TDK Corporation	CCR16.0MX7	SMD	16.0	HS	4	4	0	2.4	5.5
	CCR20.0MX7	SMD	20.0		4	4	0		

**Note** Set the flash operation mode by using CMODE1 and CMODE0 bits of the option byte (000C2H/010C2H).

**Remark** Values in parentheses in the C1, C2 columns indicate an internal capacitance.

**(3) X1 oscillation: Crystal resonator (AMPH = 0, T<sub>A</sub> = - 40 to +85° C)**

Manufacturer	Part Number	SMD/Lead	Frequency (MHz)	Flash operation mode <sup>Note1</sup>	Recommended Circuit Constants			Oscillation Voltage Range	
					C1 (pF)	C2 (pF)	Rd (kΩ)	MIN. (V)	MAX. (V)
Nihon Dempa Kogyo Co., Ltd. <sup>Note2</sup>	NX8045GB	SMD	8.0	LS	3	4	0	1.8	5.5
		SMD		HS	5	5	0	2.4	5.5

**Notes 1.** Set the flash operation mode by using CMODE1 and CMODE0 bits of the option byte (000C2H/010C2H).

**2.** When using this resonator, contact Nihon Dempa Kogyo Co., Ltd (<http://www.ndk.com/en>).

**(4) X1 oscillation: Crystal resonator (AMPH = 1, T<sub>A</sub> = - 40 to +85° C)**

Manufacturer	Part Number	SMD/Lead	Frequency (MHz)	Flash operation mode <sup>Note1</sup>	Recommended Circuit Constants			Oscillation Voltage Range	
					C1 (pF)	C2 (pF)	Rd (kΩ)	MIN. (V)	MAX. (V)
Nihon Dempa Kogyo Co., Ltd. <sup>Note2</sup>	NX5032GA	SMD	16.0	HS	6	7	0	2.4	5.5
	NX3225HA	SMD	20.0		4	5	0		

**Notes 1.** Set the flash operation mode by using CMODE1 and CMODE0 bits of the option byte (000C2H/010C2H).

**2.** When using these resonators, contact Nihon Dempa Kogyo Co., Ltd (<http://www.ndk.com/en>).

**Caution** The oscillator constants shown above are reference values based on evaluation in a specific environment by the resonator manufacturer. If it is necessary to optimize the oscillator characteristics in the actual application, apply to the resonator manufacturer for evaluation on the implementation circuit. The oscillation voltage and oscillation frequency only indicate the oscillator characteristic. Use the RL78/G13 so that the internal operation conditions are within the specifications of the DC and AC characteristics.

**Caution** The pins mounted depend on the product. Refer to 2.1.1 20-pin products to 2.1.14 128-pin products, and 2.1.15 Pins for each product (pins other than port pins).

**(5) XT1 oscillation: Crystal resonator (T<sub>A</sub> = - 40 to +85° C)**

Manufacturer	Part Number	SMD/ Lead	Frequency (KHz)	Load Capacitance CL (pF)	XT1 oscillation mode <sup>Note1</sup>	Recommended Circuit Constants			Oscillation Voltage Range	
						C1 (pF)	C2 (pF)	Rd (kΩ)	MIN. (V)	MAX. (V)
Seiko Instruments Inc. <sup>Note2</sup>	SSP-T7-F	SMD	32.768	7.0	Normal oscillation	11	11	0	1.6	5.5
	SSP-T7-FL			6.0		9	9	0		
				6.0	Low power consumption oscillation	9	9	0		
						6	5	0		
				4.4	Ultra-low power consumption oscillation	6	5	0		
	3.7			4		4	0			
	VT-200-FL	Lead	6.0	Normal oscillation	9	9	0			
			6.0	Low power consumption oscillation	9	9	0			
					6	5	0			
			4.4	Ultra-low power consumption oscillation	6	5	0			
3.7	4	4	0							
Nihon Dempa Kogyo Co., Ltd. <sup>Note3</sup>	NX3215SA	SMD	32.768	6.0	Normal oscillation	6	7	0	1.6	5.5
				6.0	Low power consumption oscillation					
						6.0	Ultra-low power consumption oscillation	<b>Note 3</b>		
KYOCERA KINSEKI Corporation	ST3215SB	SMD	32.768	7.0	Normal oscillation	10	10	0	1.6	5.5
				7.0	Low power consumption oscillation					

**Notes 1.** Set the XT1 oscillation mode by using AMPHS0, AMPHS1 bits of the Clock Operation Mode Control Register (CMC).

**2.** When using these resonators, contact Seiko Instruments Inc., Ltd (<http://www.sii-crystal.com>).

**3.** When using this resonator, contact Nihon Dempa Kogyo Co., Ltd (<http://www.ndk.com/en>).

**Caution** The oscillator constants shown above are reference values based on evaluation in a specific environment by the resonator manufacturer. If it is necessary to optimize the oscillator characteristics in the actual application, apply to the resonator manufacturer for evaluation on the implementation circuit. The oscillation voltage and oscillation frequency only indicate the oscillator characteristic. Use the RL78/G13 so that the internal operation conditions are within the specifications of the DC and AC characteristics.

**Caution** The pins mounted depend on the product. Refer to 2.1.1 20-pin products to 2.1.14 128-pin products, and 2.1.15 Pins for each product (pins other than port pins).

## 29.4 DC Characteristics

### <R> 29.4.1 Pin characteristics

( $T_A = -40$  to  $+85^\circ\text{C}$ ,  $1.6\text{ V} \leq EV_{DD0} = EV_{DD1} \leq V_{DD} \leq 5.5\text{ V}$ ,  $V_{SS} = EV_{SS0} = EV_{SS1} = 0\text{ V}$ )

Items	Symbol	Conditions	MIN.	TYP.	MAX.	Unit	
Output current, high <sup>Note 1</sup>	I <sub>OH1</sub>	Per pin for P00 to P07, P10 to P17, P30 to P37, P40 to P47, P50 to P57, P64 to P67, P70 to P77, P80 to P87, P90 to P97, P100 to P106, P110 to P117, P120, P125 to P127, P130, P140 to P147	$1.6\text{ V} \leq EV_{DD0} \leq 5.5\text{ V}$			-10.0 <sup>Note 2</sup>	mA
		Total of P00 to P04, P07, P32 to P37, P40 to P47, P102 to P106, P120, P125 to P127, P130, P140 to P145 (When duty = 70% <sup>Note 3</sup> )	$4.0\text{ V} \leq EV_{DD0} \leq 5.5\text{ V}$			-55.0	mA
			$2.7\text{ V} \leq EV_{DD0} < 4.0\text{ V}$			-10.0	mA
			$1.8\text{ V} \leq EV_{DD0} < 2.7\text{ V}$			-5.0	mA
			$1.6\text{ V} \leq EV_{DD0} < 1.8\text{ V}$			-2.5	mA
		Total of P05, P06, P10 to P17, P30, P31, P50 to P57, P64 to P67, P70 to P77, P80 to P87, P90 to P97, P100, P101, P110 to P117, P146, P147 (When duty = 70% <sup>Note 3</sup> )	$4.0\text{ V} \leq EV_{DD0} \leq 5.5\text{ V}$			-80.0	mA
			$2.7\text{ V} \leq EV_{DD0} < 4.0\text{ V}$			-19.0	mA
			$1.8\text{ V} \leq EV_{DD0} < 2.7\text{ V}$			-10.0	mA
			$1.6\text{ V} \leq EV_{DD0} < 1.8\text{ V}$			-5.0	mA
		Total of all pins (When duty = 70% <sup>Note 3</sup> )	$1.6\text{ V} \leq EV_{DD0} \leq 5.5\text{ V}$			-135.0	mA
I <sub>OH2</sub>	Per pin for P20 to P27, P150 to P156	$1.6\text{ V} \leq V_{DD} \leq 5.5\text{ V}$			-0.1 <sup>Note 2</sup>	mA	
	Total of all pins (When duty = 70% <sup>Note 3</sup> )	$1.6\text{ V} \leq V_{DD} \leq 5.5\text{ V}$			-1.5	mA	

- Notes**
- Value of current at which the device operation is guaranteed even if the current flows from the  $EV_{DD0}$ ,  $EV_{DD1}$ ,  $V_{DD}$  pins to an output pin.
  - However, do not exceed the total current value.
  - Specification under conditions where the duty factor is 70%.

The output current value that has changed the duty ratio can be calculated with the following expression (when changing the duty factor from 70% to n%).

- Total output current of pins =  $(I_{OH} \times 0.7)/(n \times 0.01)$

<Example> Where  $n = 50\%$  and  $I_{OH} = -10.0\text{ mA}$

$$\text{Total output current of pins} = (-10.0 \times 0.7)/(50 \times 0.01) = -14.0\text{ mA}$$

However, the current that is allowed to flow into one pin does not vary depending on the duty factor. A current higher than the absolute maximum rating must not flow into one pin.

**Caution** P00, P02 to P04, P10 to P15, P17, P43 to P45, P50, P52 to P55, P71, P74, P80 to P82, P96, and P142 to P144 do not output high level in N-ch open-drain mode.

**Remark** Unless specified otherwise, the characteristics of alternate-function pins are the same as those of the port pins.

**Caution** The pins mounted depend on the product. Refer to 2.1.1 20-pin products to 2.1.14 128-pin products, and 2.1.15 Pins for each product (pins other than port pins).

( $T_A = -40$  to  $+85^\circ\text{C}$ ,  $1.6\text{ V} \leq EV_{DD0} = EV_{DD1} \leq V_{DD} \leq 5.5\text{ V}$ ,  $V_{SS} = EV_{SS0} = EV_{SS1} = 0\text{ V}$ )

Items	Symbol	Conditions	MIN.	TYP.	MAX.	Unit	
Output current, low <sup>Note 1</sup>	I <sub>OL1</sub>	Per pin for P00 to P07, P10 to P17, P30 to P37, P40 to P47, P50 to P57, P64 to P67, P70 to P77, P80 to P87, P90 to P97, P100 to P106, P110 to P117, P120, P125 to P127, P130, P140 to P147			20.0 <sup>Note 2</sup>	mA	
		Per pin for P60 to P63			15.0 <sup>Note 2</sup>	mA	
		Total of P00 to P04, P07, P32 to P37, P40 to P47, P102 to P106, P120, P125 to P127, P130, P140 to P145 (When duty = 70% <sup>Note 3</sup> )	$4.0\text{ V} \leq EV_{DD0} \leq 5.5\text{ V}$			70.0	mA
			$2.7\text{ V} \leq EV_{DD0} < 4.0\text{ V}$			15.0	mA
			$1.8\text{ V} \leq EV_{DD0} < 2.7\text{ V}$			9.0	mA
			$1.6\text{ V} \leq EV_{DD0} < 1.8\text{ V}$			4.5	mA
		Total of P05, P06, P10 to P17, P30, P31, P50 to P57, P64 to P67, P70 to P77, P80 to P87, P90 to P97, P100, P101, P110 to P117, P146, P147 (When duty = 70% <sup>Note 3</sup> )	$4.0\text{ V} \leq EV_{DD0} \leq 5.5\text{ V}$			80.0	mA
			$2.7\text{ V} \leq EV_{DD0} < 4.0\text{ V}$			35.0	mA
			$1.8\text{ V} \leq EV_{DD0} < 2.7\text{ V}$			20.0	mA
			$1.6\text{ V} \leq EV_{DD0} < 1.8\text{ V}$			10.0	mA
	Total of all pins (When duty = 70% <sup>Note 3</sup> )				150.0	mA	
	I <sub>OL2</sub>	Per pin for P20 to P27, P150 to P156				0.4 <sup>Note 2</sup>	mA
Total of all pins (When duty = 70% <sup>Note 3</sup> )		$1.6\text{ V} \leq V_{DD} \leq 5.5\text{ V}$			5.0	mA	

- Notes**
- Value of current at which the device operation is guaranteed even if the current flows from an output pin to the EV<sub>SS0</sub>, EV<sub>SS1</sub> and V<sub>SS</sub> pin.
  - However, do not exceed the total current value.
  - Specification under conditions where the duty factor is 70%.

The output current value that has changed the duty ratio can be calculated with the following expression (when changing the duty factor from 70% to n%).

- Total output current of pins =  $(I_{OL} \times 0.7)/(n \times 0.01)$

<Example> Where  $n = 50\%$  and  $I_{OL} = 10.0\text{ mA}$

$$\text{Total output current of pins} = (10.0 \times 0.7)/(50 \times 0.01) = 14.0\text{ mA}$$

However, the current that is allowed to flow into one pin does not vary depending on the duty factor. A current higher than the absolute maximum rating must not flow into one pin.

**Remark** Unless specified otherwise, the characteristics of alternate-function pins are the same as those of the port pins.



**Caution** The pins mounted depend on the product. Refer to 2.1.1 20-pin products to 2.1.14 128-pin products, and 2.1.15 Pins for each product (pins other than port pins).

( $T_A = -40$  to  $+85^\circ\text{C}$ ,  $1.6\text{ V} \leq EV_{DD0} = EV_{DD1} \leq V_{DD} \leq 5.5\text{ V}$ ,  $V_{SS} = EV_{SS0} = EV_{SS1} = 0\text{ V}$ )

Items	Symbol	Conditions	MIN.	TYP.	MAX.	Unit	
Input voltage, high	$V_{IH1}$	P00 to P07, P10 to P17, P30 to P37, P40 to P47, P50 to P57, P64 to P67, P70 to P77, P80 to P87, P90 to P97, P100 to P106, P110 to P117, P120, P125 to P127, P140 to P147	Normal input buffer	$0.8EV_{DD0}$		$EV_{DD0}$	V
	$V_{IH2}$	P01, P03, P04, P10, P11, P13 to P17, P43, P44, P53 to P55, P80, P81, P142, P143	TTL input buffer $4.0\text{ V} \leq EV_{DD0} \leq 5.5\text{ V}$	2.2		$EV_{DD0}$	V
			TTL input buffer $3.3\text{ V} \leq EV_{DD0} < 4.0\text{ V}$	2.0		$EV_{DD0}$	V
			TTL input buffer $1.6\text{ V} \leq EV_{DD0} < 3.3\text{ V}$	1.5		$EV_{DD0}$	V
	$V_{IH3}$	P20 to P27, P150 to P156		$0.7V_{DD}$		$V_{DD}$	V
	$V_{IH4}$	P60 to P63		$0.7EV_{DD0}$		6.0	V
$V_{IH5}$	P121 to P124, P137, EXCLK, EXCLKS, $\overline{\text{RESET}}$		$0.8V_{DD}$		$V_{DD}$	V	
Input voltage, low	$V_{IL1}$	P00 to P07, P10 to P17, P30 to P37, P40 to P47, P50 to P57, P64 to P67, P70 to P77, P80 to P87, P90 to P97, P100 to P106, P110 to P117, P120, P125 to P127, P140 to P147	Normal input buffer	0		$0.2EV_{DD0}$	V
	$V_{IL2}$	P01, P03, P04, P10, P11, P13 to P17, P43, P44, P53 to P55, P80, P81, P142, P143	TTL input buffer $4.0\text{ V} \leq EV_{DD0} \leq 5.5\text{ V}$	0		0.8	V
			TTL input buffer $3.3\text{ V} \leq EV_{DD0} < 4.0\text{ V}$	0		0.5	V
			TTL input buffer $1.6\text{ V} \leq EV_{DD0} < 3.3\text{ V}$	0		0.32	V
	$V_{IL3}$	P20 to P27, P150 to P156		0		$0.3V_{DD}$	V
	$V_{IL4}$	P60 to P63		0		$0.3EV_{DD0}$	V
$V_{IL5}$	P121 to P124, P137, EXCLK, EXCLKS, $\overline{\text{RESET}}$		0		$0.2V_{DD}$	V	

**Caution** The maximum value of  $V_{IH}$  of pins P00, P02 to P04, P10 to P15, P17, P43 to P45, P50, P52 to P55, P71, P74, P80 to P82, P96, and P142 to P144 is  $EV_{DD0}$ , even in the N-ch open-drain mode.

**Remark** Unless specified otherwise, the characteristics of alternate-function pins are the same as those of the port pins.

**Caution** The pins mounted depend on the product. Refer to 2.1.1 20-pin products to 2.1.14 128-pin products, and 2.1.15 Pins for each product (pins other than port pins).

( $T_A = -40$  to  $+85^\circ\text{C}$ ,  $1.6\text{ V} \leq EV_{DD0} = EV_{DD1} \leq V_{DD} \leq 5.5\text{ V}$ ,  $V_{SS} = EV_{SS0} = EV_{SS1} = 0\text{ V}$ )

Items	Symbol	Conditions	MIN.	TYP.	MAX.	Unit
Output voltage, high	V <sub>OH1</sub>	P00 to P07, P10 to P17, P30 to P37, P40 to P47, P50 to P57, P64 to P67, P70 to P77, P80 to P87, P90 to P97, P100 to P106, P110 to P117, P120, P125 to P127, P130, P140 to P147	$4.0\text{ V} \leq EV_{DD0} \leq 5.5\text{ V}$ , $I_{OH1} = -10.0\text{ mA}$	$EV_{DD0} - 1.5$		V
			$4.0\text{ V} \leq EV_{DD0} \leq 5.5\text{ V}$ , $I_{OH1} = -3.0\text{ mA}$	$EV_{DD0} - 0.7$		V
			$2.7\text{ V} \leq EV_{DD0} \leq 5.5\text{ V}$ , $I_{OH1} = -2.0\text{ mA}$	$EV_{DD0} - 0.6$		V
			$1.8\text{ V} \leq EV_{DD0} \leq 5.5\text{ V}$ , $I_{OH1} = -1.5\text{ mA}$	$EV_{DD0} - 0.5$		V
			$1.6\text{ V} \leq EV_{DD0} < 1.8\text{ V}$ , $I_{OH1} = -1.0\text{ mA}$	$EV_{DD0} - 0.5$		V
	V <sub>OH2</sub>	P20 to P27, P150 to P156	$1.6\text{ V} \leq V_{DD} \leq 5.5\text{ V}$ , $I_{OH2} = -100\ \mu\text{A}$	$V_{DD} - 0.5$		V
Output voltage, low	V <sub>OL1</sub>	P00 to P07, P10 to P17, P30 to P37, P40 to P47, P50 to P57, P64 to P67, P70 to P77, P80 to P87, P90 to P97, P100 to P106, P110 to P117, P120, P125 to P127, P130, P140 to P147	$4.0\text{ V} \leq EV_{DD0} \leq 5.5\text{ V}$ , $I_{OL1} = 20\text{ mA}$		1.3	V
			$4.0\text{ V} \leq EV_{DD0} \leq 5.5\text{ V}$ , $I_{OL1} = 8.5\text{ mA}$		0.7	V
			$4.0\text{ V} \leq EV_{DD0} \leq 5.5\text{ V}$ , $I_{OL1} = 3.0\text{ mA}$		0.6	V
			$2.7\text{ V} \leq EV_{DD0} \leq 5.5\text{ V}$ , $I_{OL1} = 1.5\text{ mA}$		0.4	V
			$1.8\text{ V} \leq EV_{DD0} \leq 5.5\text{ V}$ , $I_{OL1} = 0.6\text{ mA}$		0.4	V
			$1.6\text{ V} \leq EV_{DD0} < 5.5\text{ V}$ , $I_{OL1} = 0.3\text{ mA}$		0.4	V
			V <sub>OL2</sub>	P20 to P27, P150 to P156	$1.6\text{ V} \leq V_{DD} \leq 5.5\text{ V}$ , $I_{OL2} = 400\ \mu\text{A}$	
	V <sub>OL3</sub>	P60 to P63	$4.0\text{ V} \leq EV_{DD0} \leq 5.5\text{ V}$ , $I_{OL3} = 15.0\text{ mA}$		2.0	V
			$4.0\text{ V} \leq EV_{DD0} \leq 5.5\text{ V}$ , $I_{OL3} = 5.0\text{ mA}$		0.4	V
			$2.7\text{ V} \leq EV_{DD0} \leq 5.5\text{ V}$ , $I_{OL3} = 3.0\text{ mA}$		0.4	V
			$1.8\text{ V} \leq EV_{DD0} \leq 5.5\text{ V}$ , $I_{OL3} = 2.0\text{ mA}$		0.4	V
			$1.6\text{ V} \leq EV_{DD0} < 5.5\text{ V}$ , $I_{OL3} = 1.0\text{ mA}$		0.4	V

**Caution** P00, P02 to P04, P10 to P15, P17, P43 to P45, P50, P52 to P55, P71, P74, P80 to P82, P96, and P142 to P144 do not output high level in N-ch open-drain mode.

**Remark** Unless specified otherwise, the characteristics of alternate-function pins are the same as those of the port pins.

**Caution** The pins mounted depend on the product. Refer to 2.1.1 20-pin products to 2.1.14 128-pin products, and 2.1.15 Pins for each product (pins other than port pins).

( $T_A = -40$  to  $+85^\circ\text{C}$ ,  $1.6\text{ V} \leq EV_{DD0} = EV_{DD1} \leq V_{DD} \leq 5.5\text{ V}$ ,  $V_{SS} = EV_{SS0} = EV_{SS1} = 0\text{ V}$ )

Items	Symbol	Conditions	MIN.	TYP.	MAX.	Unit	
Input leakage current, high	$I_{LH1}$	P00 to P07, P10 to P17, P30 to P37, P40 to P47, P50 to P57, P60 to P67, P70 to P77, P80 to P87, P90 to P97, P100 to P106, P110 to P117, P120, P125 to P127, P140 to P147	$V_i = EV_{DD0}$			1	$\mu\text{A}$
	$I_{LH2}$	P20 to P27, P137, P150 to P156, RESET	$V_i = V_{DD}$			1	$\mu\text{A}$
	$I_{LH3}$	P121 to P124 (X1, X2, XT1, XT2, EXCLK, EXCLKS)	$V_i = V_{DD}$	In input port or external clock input			1
In resonator connection						10	$\mu\text{A}$
Input leakage current, low	$I_{LIL1}$	P00 to P07, P10 to P17, P30 to P37, P40 to P47, P50 to P57, P60 to P67, P70 to P77, P80 to P87, P90 to P97, P100 to P106, P110 to P117, P120, P125 to P127, P140 to P147	$V_i = EV_{SS0}$			-1	$\mu\text{A}$
	$I_{LIL2}$	P20 to P27, P137, $\overline{\text{RESET}}$	$V_i = V_{SS}$			-1	$\mu\text{A}$
	$I_{LIL3}$	P121 to P124 (X1, X2, XT1, XT2, EXCLK, EXCLKS)	$V_i = V_{SS}$	In input port or external clock input			-1
In resonator connection						-10	$\mu\text{A}$
On-chip pll-up resistance	$R_u$	P00 to P07, P10 to P17, P30 to P37, P40 to P47, P50 to P57, P64 to P67, P70 to P77, P80 to P87, P90 to P97, P100 to P106, P110 to P117, P120, P125 to P127, P140 to P147	$V_i = EV_{SS0}$ , In input port	10	20	100	$\text{k}\Omega$

**Remark** Unless specified otherwise, the characteristics of alternate-function pins are the same as those of the port pins.

**Caution** The pins mounted depend on the product. Refer to 2.1.1 20-pin products to 2.1.14 128-pin products, and 2.1.15 Pins for each product (pins other than port pins).

### 29.4.2 Supply current characteristics

#### <R> (1) Flash ROM: 16 to 64 KB of 20- to 64-pin products

( $T_A = -40$  to  $+85^\circ\text{C}$ ,  $1.6\text{ V} \leq EV_{DD0} = EV_{DD1} \leq V_{DD} \leq 5.5\text{ V}$ ,  $V_{SS} = EV_{SS0} = EV_{SS1} = 0\text{ V}$ )

(1/2)

Parameter	Symbol	Conditions				MIN.	TYP.	MAX.	Unit	
Supply current	I <sub>DD1</sub> <sup>Note 1</sup>	Operating mode	High-speed operation <sup>Note 5</sup>	f <sub>IH</sub> = 32 MHz <sup>Note 3</sup>	Basic operation	V <sub>DD</sub> = 5.0 V		2.1		mA
						V <sub>DD</sub> = 3.0 V		2.1		mA
				Normal operation	V <sub>DD</sub> = 5.0 V		4.6	7.0	mA	
					V <sub>DD</sub> = 3.0 V		4.6	7.0	mA	
				f <sub>IH</sub> = 24 MHz <sup>Note 3</sup>	Normal operation	V <sub>DD</sub> = 5.0 V		3.7	5.5	mA
						V <sub>DD</sub> = 3.0 V		3.7	5.5	mA
			f <sub>IH</sub> = 16 MHz <sup>Note 3</sup>	Normal operation	V <sub>DD</sub> = 5.0 V		2.7	4.0	mA	
					V <sub>DD</sub> = 3.0 V		2.7	4.0	mA	
			Low-speed operation <sup>Note 5</sup>	f <sub>IH</sub> = 8 MHz <sup>Note 3</sup>	Normal operation	V <sub>DD</sub> = 3.0 V		1.2	1.8	mA
						V <sub>DD</sub> = 2.0 V		1.2	1.8	mA
			Low-voltage operation <sup>Note 5</sup>	f <sub>IH</sub> = 4 MHz <sup>Note 3</sup>	Normal operation	V <sub>DD</sub> = 3.0 V		1.2	1.7	mA
						V <sub>DD</sub> = 2.0 V		1.2	1.7	mA
			High-speed operation <sup>Note 5</sup>	f <sub>MX</sub> = 20 MHz <sup>Note 2</sup> , V <sub>DD</sub> = 5.0 V	Normal operation	Square wave input		3.0	4.6	mA
						Resonator connection		3.2	4.8	mA
					Normal operation	Square wave input		3.0	4.6	mA
						Resonator connection		3.2	4.8	mA
				f <sub>MX</sub> = 10 MHz <sup>Note 2</sup> , V <sub>DD</sub> = 5.0 V	Normal operation	Square wave input		1.9	2.7	mA
						Resonator connection		1.9	2.7	mA
				f <sub>MX</sub> = 10 MHz <sup>Note 2</sup> , V <sub>DD</sub> = 3.0 V	Normal operation	Square wave input		1.9	2.7	mA
						Resonator connection		1.9	2.7	mA
			Low-speed operation <sup>Note 5</sup>	f <sub>MX</sub> = 8 MHz <sup>Note 2</sup> , V <sub>DD</sub> = 3.0 V	Normal operation	Square wave input		1.1	1.7	mA
						Resonator connection		1.1	1.7	mA
				f <sub>MX</sub> = 8 MHz <sup>Note 2</sup> , V <sub>DD</sub> = 2.0 V	Normal operation	Square wave input		1.1	1.7	mA
						Resonator connection		1.1	1.7	mA
Subsystem clock operation	f <sub>SUB</sub> = 32.768 kHz <sup>Note 4</sup> T <sub>A</sub> = -40°C	Normal operation	Resonator connection		4.1		μA			
			Square wave input		4.2		μA			
	f <sub>SUB</sub> = 32.768 kHz <sup>Note 4</sup> T <sub>A</sub> = +25°C	Normal operation	Square wave input		4.1	4.9	μA			
			Resonator connection		4.2	5.0	μA			
	f <sub>SUB</sub> = 32.768 kHz <sup>Note 4</sup> T <sub>A</sub> = +50°C	Normal operation	Square wave input		4.2	5.5	μA			
			Resonator connection		4.3	5.6	μA			
	f <sub>SUB</sub> = 32.768 kHz <sup>Note 4</sup> T <sub>A</sub> = +70°C	Normal operation	Square wave input		4.2	6.3	μA			
			Resonator connection		4.3	6.4	μA			
f <sub>SUB</sub> = 32.768 kHz <sup>Note 4</sup> T <sub>A</sub> = +85°C	Normal operation	Square wave input		4.8	7.7	μA				
		Resonator connection		4.9	7.8	μA				

(Notes and Remarks are listed on the next page.)

**Caution** The pins mounted depend on the product. Refer to 2.1.1 20-pin products to 2.1.14 128-pin products, and 2.1.15 Pins for each product (pins other than port pins).

- Notes**
1. Total current flowing into  $V_{DD}$  and  $EV_{DD0}$ , including the input leakage current flowing when the level of the input pin is fixed to  $V_{DD}$ ,  $EV_{DD0}$  or  $V_{SS}$ ,  $EV_{SS0}$ . The values below the MAX. column include the peripheral operation current (except for background operation (BGO)). However, not including the current flowing into the A/D converter, LVD circuit, I/O port, and on-chip pull-up/pull-down resistors.
  2. When high-speed on-chip oscillator and subsystem clock are stopped.
  3. When high-speed system clock and subsystem clock are stopped.
  4. When high-speed on-chip oscillator and high-speed system clock are stopped. When real-time counter and watchdog timer is stopped. When AMPHS1 = 1 (Ultra-low power consumption oscillation).
  5. Relationship between operation voltage width, operation frequency of CPU and operation mode is as below.  
 High speed operation:  $V_{DD} = 2.4\text{ V to }5.5\text{ V}@1\text{ MHz to }32\text{ MHz}$   
 Low speed operation:  $V_{DD} = 1.8\text{ V to }5.5\text{ V}@1\text{ MHz to }8\text{ MHz}$   
 Low voltage operation:  $V_{DD} = 1.6\text{ V to }5.5\text{ V}@1\text{ MHz to }4\text{ MHz}$

- Remarks**
1.  $f_{MX}$ : High-speed system clock frequency (X1 clock oscillation frequency or external main system clock frequency)
  2.  $f_{IH}$ : High-speed on-chip oscillator clock frequency
  3.  $f_{SUB}$ : Subsystem clock frequency (XT1 clock oscillation frequency)
  4. Except subsystem clock operation, temperature condition of the TYP. value is  $T_A = 25^\circ\text{C}$

<R>

**Caution** The pins mounted depend on the product. Refer to 2.1.1 20-pin products to 2.1.14 128-pin products, and 2.1.15 Pins for each product (pins other than port pins).

<R> (1) Flash ROM: 16 to 64 KB of 20- to 64-pin products

( $T_A = -40$  to  $+85^\circ\text{C}$ ,  $1.6\text{ V} \leq EV_{DD0} = EV_{DD1} \leq V_{DD} \leq 5.5\text{ V}$ ,  $V_{SS} = EV_{SS0} = EV_{SS1} = 0\text{ V}$ )

(2/2)

Parameter	Symbol	Conditions		MIN.	TYP.	MAX.	Unit	
Supply current Note 1	I <sub>DD2</sub> Note 2	HALT mode	High-speed operation Note 7	f <sub>IH</sub> = 32 MHz <sup>Note 4</sup>	V <sub>DD</sub> = 5.0 V	0.54	1.63	mA
					V <sub>DD</sub> = 3.0 V	0.54	1.63	mA
				f <sub>IH</sub> = 24 MHz <sup>Note 4</sup>	V <sub>DD</sub> = 5.0 V	0.44	1.28	mA
					V <sub>DD</sub> = 3.0 V	0.44	1.28	mA
				f <sub>IH</sub> = 16 MHz <sup>Note 4</sup>	V <sub>DD</sub> = 5.0 V	0.40	1.00	mA
					V <sub>DD</sub> = 3.0 V	0.40	1.00	mA
			Low-speed operation Note 7	f <sub>IH</sub> = 8 MHz <sup>Note 4</sup>	V <sub>DD</sub> = 3.0 V	260	530	μA
					V <sub>DD</sub> = 2.0 V	260	530	μA
			Low-voltage operation Note 7	f <sub>IH</sub> = 4 MHz <sup>Note 4</sup>	V <sub>DD</sub> = 3.0 V	420	640	μA
					V <sub>DD</sub> = 2.0 V	420	640	μA
			High-speed operation Note 7	f <sub>MX</sub> = 20 MHz <sup>Note 3</sup> , V <sub>DD</sub> = 5.0 V	Square wave input	0.28	1.00	mA
					Resonator connection	0.45	1.17	mA
				f <sub>MX</sub> = 20 MHz <sup>Note 3</sup> , V <sub>DD</sub> = 3.0 V	Square wave input	0.28	1.00	mA
					Resonator connection	0.45	1.17	mA
				f <sub>MX</sub> = 10 MHz <sup>Note 3</sup> , V <sub>DD</sub> = 5.0 V	Square wave input	0.19	0.60	mA
					Resonator connection	0.26	0.67	mA
				f <sub>MX</sub> = 10 MHz <sup>Note 3</sup> , V <sub>DD</sub> = 3.0 V	Square wave input	0.19	0.60	mA
					Resonator connection	0.26	0.67	mA
			Low-speed operation Note 7	f <sub>MX</sub> = 8 MHz <sup>Note 3</sup> , V <sub>DD</sub> = 3.0 V	Square wave input	95	330	μA
					Resonator connection	145	380	μA
				f <sub>MX</sub> = 8 MHz <sup>Note 3</sup> , V <sub>DD</sub> = 2.0 V	Square wave input	95	330	μA
					Resonator connection	145	380	μA
			Subsystem clock operation	f <sub>SUB</sub> = 32.768 kHz <sup>Note 5</sup> T <sub>A</sub> = -40°C	Square wave input	0.25		μA
					Resonator connection	0.44		μA
				f <sub>SUB</sub> = 32.768 kHz <sup>Note 5</sup> T <sub>A</sub> = +25°C	Square wave input	0.30	0.57	μA
					Resonator connection	0.49	0.76	μA
				f <sub>SUB</sub> = 32.768 kHz <sup>Note 5</sup> T <sub>A</sub> = +50°C	Square wave input	0.33	1.17	μA
					Resonator connection	0.52	1.36	μA
				f <sub>SUB</sub> = 32.768 kHz <sup>Note 5</sup> T <sub>A</sub> = +70°C	Square wave input	0.36	1.97	μA
					Resonator connection	0.55	2.16	μA
f <sub>SUB</sub> = 32.768 kHz <sup>Note 5</sup> T <sub>A</sub> = +85°C	Square wave input	0.97	3.37	μA				
	Resonator connection	1.16	3.56	μA				
I <sub>DD3</sub> Note 6	STOP mode	T <sub>A</sub> = -40°C		0.18		μA		
		T <sub>A</sub> = +25°C		0.23	0.50	μA		
		T <sub>A</sub> = +50°C		0.26	1.10	μA		
		T <sub>A</sub> = +70°C		0.29	1.90	μA		
		T <sub>A</sub> = +85°C		0.90	3.30	μA		

(Notes and Remarks are listed on the next page.)

**Caution** The pins mounted depend on the product. Refer to 2.1.1 20-pin products to 2.1.14 128-pin products, and 2.1.15 Pins for each product (pins other than port pins).

**Notes** 1. Total current flowing into  $V_{DD}$  and  $EV_{DD0}$ , including the input leakage current flowing when the level of the input pin is fixed to  $V_{DD}$ ,  $EV_{DD0}$  or  $V_{SS}$ ,  $EV_{SS0}$ . The values below the MAX. column include the peripheral operation current. However, not including the current flowing into the A/D converter, LVD circuit, I/O port, and on-chip pull-up/pull-down resistors.

2. During HALT instruction execution by flash memory.

3. When high-speed on-chip oscillator and subsystem clock are stopped.

4. When high-speed system clock and subsystem clock are stopped.

5. When operating real-time clock (RTC) and setting ultra-low current consumption ( $AMPHS1 = 1$ ). When high-speed on-chip oscillator and high-speed system clock are stopped. When watchdog timer is stopped. The values below the MAX. column include the leakage current.

<R>

6. When high-speed on-chip oscillator, high-speed system clock, and subsystem clock are stopped. When watchdog timer is stopped. The values below the MAX. column include the leakage current.

7. Relationship between operation voltage width, operation frequency of CPU and operation mode is as below.

High speed operation:  $V_{DD} = 2.4 \text{ V to } 5.5 \text{ V}@1 \text{ MHz to } 32 \text{ MHz}$

Low speed operation:  $V_{DD} = 1.8 \text{ V to } 5.5 \text{ V}@1 \text{ MHz to } 8 \text{ MHz}$

Low voltage operation:  $V_{DD} = 1.6 \text{ V to } 5.5 \text{ V}@1 \text{ MHz to } 4 \text{ MHz}$

**Remarks** 1.  $f_{MX}$ : High-speed system clock frequency (X1 clock oscillation frequency or external main system clock frequency)

2.  $f_{IH}$ : High-speed on-chip oscillator clock frequency

3.  $f_{SUB}$ : Subsystem clock frequency (XT1 clock oscillation frequency)

<R>

4. Except subsystem clock operation and STOP mode, temperature condition of the TYP. value is  $T_A = 25^\circ\text{C}$

**Caution** The pins mounted depend on the product. Refer to 2.1.1 20-pin products to 2.1.14 128-pin products, and 2.1.15 Pins for each product (pins other than port pins).

<R> (2) Flash ROM: 96 to 256 KB of 30- to 100-pin products

( $T_A = -40$  to  $+85^\circ\text{C}$ ,  $1.6\text{ V} \leq EV_{DD0} = EV_{DD1} \leq V_{DD} \leq 5.5\text{ V}$ ,  $V_{SS} = EV_{SS0} = EV_{SS1} = 0\text{ V}$ ) (1/2)

Parameter	Symbol	Conditions				MIN.	TYP.	MAX.	Unit			
Supply current	I <sub>DD1</sub> <sup>Note 1</sup>	Operating mode	High-speed operation <sup>Note 5</sup>	f <sub>IH</sub> = 32 MHz <sup>Note 3</sup>	Basic operation	V <sub>DD</sub> = 5.0 V		2.3		mA		
						V <sub>DD</sub> = 3.0 V		2.3		mA		
					Normal operation	V <sub>DD</sub> = 5.0 V		5.2	8.5	mA		
						V <sub>DD</sub> = 3.0 V		5.2	8.5	mA		
					Normal operation	V <sub>DD</sub> = 5.0 V		4.1	6.6	mA		
						V <sub>DD</sub> = 3.0 V		4.1	6.6	mA		
				f <sub>IH</sub> = 24 MHz <sup>Note 3</sup>	Normal operation	V <sub>DD</sub> = 5.0 V		4.1	6.6	mA		
						V <sub>DD</sub> = 3.0 V		4.1	6.6	mA		
					Normal operation	V <sub>DD</sub> = 5.0 V		3.0	4.7	mA		
						V <sub>DD</sub> = 3.0 V		3.0	4.7	mA		
					Low-speed operation <sup>Note 5</sup>	f <sub>IH</sub> = 8 MHz <sup>Note 3</sup>	Normal operation	V <sub>DD</sub> = 3.0 V		1.3	2.1	mA
								V <sub>DD</sub> = 2.0 V		1.3	2.1	mA
			Low-voltage operation <sup>Note 5</sup>	f <sub>IH</sub> = 4 MHz <sup>Note 3</sup>	Normal operation	V <sub>DD</sub> = 3.0 V		1.3	1.8	mA		
						V <sub>DD</sub> = 2.0 V		1.3	1.8	mA		
			High-speed operation <sup>Note 5</sup>	f <sub>MX</sub> = 20 MHz <sup>Note 2</sup> , V <sub>DD</sub> = 5.0 V	Normal operation	Square wave input		3.4	5.5	mA		
						Resonator connection		3.6	5.7	mA		
					Normal operation	Square wave input		3.4	5.5	mA		
						Resonator connection		3.6	5.7	mA		
					Normal operation	Square wave input		2.1	3.2	mA		
						Resonator connection		2.1	3.2	mA		
				f <sub>MX</sub> = 10 MHz <sup>Note 2</sup> , V <sub>DD</sub> = 3.0 V	Normal operation	Square wave input		2.1	3.2	mA		
						Resonator connection		2.1	3.2	mA		
					Normal operation	Square wave input		1.2	2.0	mA		
						Resonator connection		1.2	2.0	mA		
					Normal operation	Square wave input		1.2	2.0	mA		
						Resonator connection		1.2	2.0	mA		
			Low-speed operation <sup>Note 5</sup>	f <sub>SUB</sub> = 32.768 kHz <sup>Note 4</sup> T <sub>A</sub> = -40°C	Normal operation	Square wave input		4.8		μA		
						Resonator connection		4.9		μA		
Normal operation	Square wave input				4.9	5.9	μA					
	Resonator connection				5.0	6.0	μA					
Normal operation	Square wave input				4.9	7.6	μA					
	Resonator connection				5.0	7.7	μA					
f <sub>SUB</sub> = 32.768 kHz <sup>Note 4</sup> T <sub>A</sub> = +25°C	Normal operation	Square wave input			5.2	9.3	μA					
		Resonator connection			5.3	9.4	μA					
	Normal operation	Square wave input			6.1	13.3	μA					
		Resonator connection			6.2	13.4	μA					
	Normal operation	Square wave input			6.1	13.3	μA					
		Resonator connection			6.2	13.4	μA					

(Notes and Remarks are listed on the next page.)



**Caution** The pins mounted depend on the product. Refer to 2.1.1 20-pin products to 2.1.14 128-pin products, and 2.1.15 Pins for each product (pins other than port pins).

- Notes**
1. Total current flowing into  $V_{DD}$ ,  $EV_{DD0}$  and  $EV_{DD1}$ , including the input leakage current flowing when the level of the input pin is fixed to  $V_{DD}$ ,  $EV_{DD0}$  or  $V_{SS}$ ,  $EV_{SS0}$ . The values below the MAX. column include the peripheral operation current (except for background operation (BGO)). However, not including the current flowing into the A/D converter, LVD circuit, I/O port, and on-chip pull-up/pull-down resistors.
  2. When high-speed on-chip oscillator and subsystem clock are stopped.
  3. When high-speed system clock and subsystem clock are stopped.
  4. When high-speed on-chip oscillator and high-speed system clock are stopped. When real-time counter and watchdog timer is stopped. When AMPHS1 = 1 (Ultra-low power consumption oscillation).
  5. Relationship between operation voltage width, operation frequency of CPU and operation mode is as below.  
 High speed operation:  $V_{DD} = 2.4\text{ V to }5.5\text{ V}@1\text{ MHz to }32\text{ MHz}$   
 Low speed operation:  $V_{DD} = 1.8\text{ V to }5.5\text{ V}@1\text{ MHz to }8\text{ MHz}$   
 Low voltage operation:  $V_{DD} = 1.6\text{ V to }5.5\text{ V}@1\text{ MHz to }4\text{ MHz}$

- Remarks**
1.  $f_{MX}$ : High-speed system clock frequency (X1 clock oscillation frequency or external main system clock frequency)
  2.  $f_{IH}$ : High-speed on-chip oscillator clock frequency
  3.  $f_{SUB}$ : Subsystem clock frequency (XT1 clock oscillation frequency)
  4. Except subsystem clock operation, temperature condition of the TYP. value is  $T_A = 25^\circ\text{C}$

<R>

**Caution** The pins mounted depend on the product. Refer to 2.1.1 20-pin products to 2.1.14 128-pin products, and 2.1.15 Pins for each product (pins other than port pins).

<R> (2) Flash ROM: 96 to 256 KB of 30- to 100-pin products

( $T_A = -40$  to  $+85^\circ\text{C}$ ,  $1.6\text{ V} \leq EV_{DD0} = EV_{DD1} \leq V_{DD} \leq 5.5\text{ V}$ ,  $V_{SS} = EV_{SS0} = EV_{SS1} = 0\text{ V}$ ) (2/2)

Parameter	Symbol	Conditions		MIN.	TYP.	MAX.	Unit		
Supply current Note 1	I <sub>DD2</sub> Note 2	HALT mode	High-speed operation Note 7	f <sub>IH</sub> = 32 MHz <sup>Note 4</sup>	V <sub>DD</sub> = 5.0 V	0.62	1.86	mA	
					V <sub>DD</sub> = 3.0 V	0.62	1.86	mA	
				f <sub>IH</sub> = 24 MHz <sup>Note 4</sup>	V <sub>DD</sub> = 5.0 V	0.50	1.45	mA	
					V <sub>DD</sub> = 3.0 V	0.50	1.45	mA	
				f <sub>IH</sub> = 16 MHz <sup>Note 4</sup>	V <sub>DD</sub> = 5.0 V	0.44	1.11	mA	
					V <sub>DD</sub> = 3.0 V	0.44	1.11	mA	
			Low-speed operation Note 7	f <sub>IH</sub> = 8 MHz <sup>Note 4</sup>	V <sub>DD</sub> = 3.0 V	290	620	μA	
					V <sub>DD</sub> = 2.0 V	290	620	μA	
			Low-voltage operation Note 7	f <sub>IH</sub> = 4 MHz <sup>Note 4</sup>	V <sub>DD</sub> = 3.0 V	440	680	μA	
					V <sub>DD</sub> = 2.0 V	440	680	μA	
			High-speed operation Note 7	f <sub>MX</sub> = 20 MHz <sup>Note 3</sup> , V <sub>DD</sub> = 5.0 V	Square wave input	0.31	1.08	mA	
					Resonator connection	0.48	1.28	mA	
					f <sub>MX</sub> = 20 MHz <sup>Note 3</sup> , V <sub>DD</sub> = 3.0 V	Square wave input	0.31	1.08	mA
						Resonator connection	0.48	1.28	mA
					f <sub>MX</sub> = 10 MHz <sup>Note 3</sup> , V <sub>DD</sub> = 5.0 V	Square wave input	0.21	0.63	mA
						Resonator connection	0.28	0.71	mA
					f <sub>MX</sub> = 10 MHz <sup>Note 3</sup> , V <sub>DD</sub> = 3.0 V	Square wave input	0.21	0.63	mA
						Resonator connection	0.28	0.71	mA
			Low-speed operation Note 7	f <sub>MX</sub> = 8 MHz <sup>Note 3</sup> , V <sub>DD</sub> = 3.0 V	Square wave input	110	360	μA	
					Resonator connection	160	420	μA	
				f <sub>MX</sub> = 8 MHz <sup>Note 3</sup> , V <sub>DD</sub> = 2.0 V	Square wave input	110	360	μA	
					Resonator connection	160	420	μA	
			Subsystem clock operation	f <sub>SUB</sub> = 32.768 kHz <sup>Note 5</sup> T <sub>A</sub> = -40°C	Square wave input	0.28		μA	
					Resonator connection	0.47		μA	
				f <sub>SUB</sub> = 32.768 kHz <sup>Note 5</sup> T <sub>A</sub> = +25°C	Square wave input	0.34	0.61	μA	
					Resonator connection	0.53	0.80	μA	
				f <sub>SUB</sub> = 32.768 kHz <sup>Note 5</sup> T <sub>A</sub> = +50°C	Square wave input	0.37	2.30	μA	
					Resonator connection	0.56	2.49	μA	
f <sub>SUB</sub> = 32.768 kHz <sup>Note 5</sup> T <sub>A</sub> = +70°C	Square wave input	0.61		4.03	μA				
	Resonator connection	0.80		4.22	μA				
f <sub>SUB</sub> = 32.768 kHz <sup>Note 5</sup> T <sub>A</sub> = +85°C	Square wave input	1.55	8.04	μA					
	Resonator connection	1.74	8.23	μA					
I <sub>DD3</sub> Note 6	STOP mode	T <sub>A</sub> = -40°C		0.19		μA			
		T <sub>A</sub> = +25°C		0.25	0.52	μA			
		T <sub>A</sub> = +50°C		0.28	2.21	μA			
		T <sub>A</sub> = +70°C		0.52	3.94	μA			
		T <sub>A</sub> = +85°C		1.46	7.95	μA			

(Notes and Remarks are listed on the next page.)

**Caution** The pins mounted depend on the product. Refer to 2.1.1 20-pin products to 2.1.14 128-pin products, and 2.1.15 Pins for each product (pins other than port pins).

- Notes**
1. Total current flowing into  $V_{DD}$ ,  $EV_{DD0}$  and  $EV_{DD1}$ , including the input leakage current flowing when the level of the input pin is fixed to  $V_{DD}$ ,  $EV_{DD0}$  or  $V_{SS}$ ,  $EV_{SS0}$ . The values below the MAX. column include the peripheral operation current. However, not including the current flowing into the A/D converter, LVD circuit, I/O port, and on-chip pull-up/pull-down resistors.
  2. During HALT instruction execution by flash memory.
  3. When high-speed on-chip oscillator and subsystem clock are stopped.
  4. When high-speed system clock and subsystem clock are stopped.
  5. When operating real-time clock (RTC) and setting ultra-low current consumption ( $AMPHS1 = 1$ ). When high-speed on-chip oscillator and high-speed system clock are stopped. When watchdog timer is stopped. The values below the MAX. column include the leakage current.
  6. When high-speed on-chip oscillator, high-speed system clock, and subsystem clock are stopped. When watchdog timer is stopped. The values below the MAX. column include the leakage current.
  7. Relationship between operation voltage width, operation frequency of CPU and operation mode is as below.  
 High speed operation:  $V_{DD} = 2.4 \text{ V to } 5.5 \text{ V}@1 \text{ MHz to } 32 \text{ MHz}$   
 Low speed operation:  $V_{DD} = 1.8 \text{ V to } 5.5 \text{ V}@1 \text{ MHz to } 8 \text{ MHz}$   
 Low voltage operation:  $V_{DD} = 1.6 \text{ V to } 5.5 \text{ V}@1 \text{ MHz to } 4 \text{ MHz}$

- Remarks**
1.  $f_{MX}$ : High-speed system clock frequency (X1 clock oscillation frequency or external main system clock frequency)
  2.  $f_{IH}$ : High-speed on-chip oscillator clock frequency
  3.  $f_{SUB}$ : Subsystem clock frequency (XT1 clock oscillation frequency)
  4. Except subsystem clock operation and STOP mode, temperature condition of the TYP. value is  $T_A = 25^\circ\text{C}$

<R>

**Caution** The pins mounted depend on the product. Refer to 2.1.1 20-pin products to 2.1.14 128-pin products, and 2.1.15 Pins for each product (pins other than port pins).

**(3) 128-pin products, and flash ROM: 384 to 512 KB of 44- to 100-pin products**

**Preliminary**

( $T_A = -40$  to  $+85^\circ\text{C}$ ,  $1.6\text{ V} \leq EV_{DD0} = EV_{DD1} \leq V_{DD} \leq 5.5\text{ V}$ ,  $V_{SS} = EV_{SS0} = EV_{SS1} = 0\text{ V}$ )

(1/2)

Parameter	Symbol	Conditions				MIN.	TYP.	MAX.	Unit		
Supply current	I <sub>DD1</sub> <sup>Note 1</sup>	Operating mode	High-speed operation <sup>Note 5</sup>	f <sub>IH</sub> = 32 MHz <sup>Note 3</sup>	Basic operation	V <sub>DD</sub> = 5.0 V		2.6		mA	
						V <sub>DD</sub> = 3.0 V		2.6		mA	
					Normal operation	V <sub>DD</sub> = 5.0 V		5.5	8.5	mA	
						V <sub>DD</sub> = 3.0 V		5.5	8.5	mA	
					Normal operation	V <sub>DD</sub> = 5.0 V		4.4	6.8	mA	
						V <sub>DD</sub> = 3.0 V		4.4	6.8	mA	
				f <sub>IH</sub> = 24 MHz <sup>Note 3</sup>	Normal operation	V <sub>DD</sub> = 5.0 V		4.4	6.8	mA	
						V <sub>DD</sub> = 3.0 V		4.4	6.8	mA	
					Normal operation	V <sub>DD</sub> = 5.0 V		3.3	5.1	mA	
						V <sub>DD</sub> = 3.0 V		3.3	5.1	mA	
					Normal operation	V <sub>DD</sub> = 3.0 V		1.5	2.3	mA	
						V <sub>DD</sub> = 2.0 V		1.5	2.3	mA	
			Low-voltage operation <sup>Note 5</sup>	f <sub>IH</sub> = 4 MHz <sup>Note 3</sup>	Normal operation	V <sub>DD</sub> = 3.0 V		1.5	2.0	mA	
						V <sub>DD</sub> = 2.0 V		1.5	2.0	mA	
			High-speed operation <sup>Note 5</sup>	f <sub>MX</sub> = 20 MHz <sup>Note 2</sup> , V <sub>DD</sub> = 5.0 V	Normal operation	Square wave input		3.7	5.6	mA	
						Resonator connection		3.8	5.7	mA	
					Normal operation	Square wave input		3.7	5.6	mA	
						Resonator connection		3.8	5.7	mA	
					Normal operation	Square wave input		2.2	3.0	mA	
						Resonator connection		2.3	3.1	mA	
					Normal operation	Square wave input		2.2	3.0	mA	
						Resonator connection		2.3	3.1	mA	
				Low-speed operation <sup>Note 5</sup>	f <sub>MX</sub> = 8 MHz <sup>Note 2</sup> , V <sub>DD</sub> = 3.0 V	Normal operation	Square wave input		1.4	2.2	mA
							Resonator connection		1.4	2.2	mA
					Normal operation	Square wave input		1.4	2.2	mA	
						Resonator connection		1.4	2.2	mA	
			Subsystem clock operation	f <sub>SUB</sub> = 32.768 kHz <sup>Note 4</sup> T <sub>A</sub> = -40°C	Normal operation	Square wave input				μA	
						Resonator connection				μA	
Normal operation	Square wave input				5.1		μA				
	Resonator connection				5.1		μA				
Normal operation	Square wave input						μA				
	Resonator connection						μA				
f <sub>SUB</sub> = 32.768 kHz <sup>Note 4</sup> T <sub>A</sub> = +25°C	Normal operation	Square wave input					μA				
		Resonator connection					μA				
	Normal operation	Square wave input					μA				
		Resonator connection					μA				
	Normal operation	Square wave input					μA				
		Resonator connection					μA				
f <sub>SUB</sub> = 32.768 kHz <sup>Note 4</sup> T <sub>A</sub> = +50°C	Normal operation	Square wave input				μA					
		Resonator connection				μA					
	Normal operation	Square wave input				μA					
		Resonator connection				μA					
	Normal operation	Square wave input				μA					
		Resonator connection				μA					
f <sub>SUB</sub> = 32.768 kHz <sup>Note 4</sup> T <sub>A</sub> = +70°C	Normal operation	Square wave input				μA					
		Resonator connection				μA					
	Normal operation	Square wave input				μA					
		Resonator connection				μA					
	Normal operation	Square wave input				μA					
		Resonator connection				μA					
f <sub>SUB</sub> = 32.768 kHz <sup>Note 4</sup> T <sub>A</sub> = +85°C	Normal operation	Square wave input				μA					
		Resonator connection				μA					
	Normal operation	Square wave input				μA					
		Resonator connection				μA					
	Normal operation	Square wave input				μA					
		Resonator connection				μA					

<R>

<R> **Caution** 128-pin products, and flash ROM: 384 to 512 KB of 44- to 100-pin products, these specifications show target values, which may change after device evaluation.

(Notes and Remarks are listed on the next page.)

**Caution** The pins mounted depend on the product. Refer to 2.1.1 20-pin products to 2.1.14 128-pin products, and 2.1.15 Pins for each product (pins other than port pins).

- Notes**
1. Total current flowing into  $V_{DD}$ ,  $EV_{DD0}$  and  $EV_{DD1}$ , including the input leakage current flowing when the level of the input pin is fixed to  $V_{DD}$ ,  $EV_{DD0}$  or  $V_{SS}$ ,  $EV_{SS0}$ . The values below the MAX. column include the peripheral operation current (except for background operation (BGO)). However, not including the current flowing into the A/D converter, LVD circuit, I/O port, and on-chip pull-up/pull-down resistors.
  2. When high-speed on-chip oscillator and subsystem clock are stopped.
  3. When high-speed system clock and subsystem clock are stopped.
  4. When high-speed on-chip oscillator and high-speed system clock are stopped. When real-time counter and watchdog timer is stopped. When AMPHS1 = 1 (Ultra-low power consumption oscillation).
  5. Relationship between operation voltage width, operation frequency of CPU and operation mode is as below.  
 High speed operation:  $V_{DD} = 2.4\text{ V to }5.5\text{ V}@1\text{ MHz to }32\text{ MHz}$   
 Low speed operation:  $V_{DD} = 1.8\text{ V to }5.5\text{ V}@1\text{ MHz to }8\text{ MHz}$   
 Low voltage operation:  $V_{DD} = 1.6\text{ V to }5.5\text{ V}@1\text{ MHz to }4\text{ MHz}$

- Remarks**
1.  $f_{MX}$ : High-speed system clock frequency (X1 clock oscillation frequency or external main system clock frequency)
  2.  $f_{IH}$ : High-speed on-chip oscillator clock frequency
  3.  $f_{SUB}$ : Subsystem clock frequency (XT1 clock oscillation frequency)
  4. Except subsystem clock operation, temperature condition of the TYP. value is  $T_A = 25^\circ\text{C}$

<R>

**Caution** The pins mounted depend on the product. Refer to 2.1.1 20-pin products to 2.1.14 128-pin products, and 2.1.15 Pins for each product (pins other than port pins).

**(3) 128-pin products, and flash ROM: 384 to 512 KB of 44- to 100-pin products**

**Preliminary**

( $T_A = -40$  to  $+85^\circ\text{C}$ ,  $1.6\text{ V} \leq EV_{DD0} = EV_{DD1} \leq V_{DD} \leq 5.5\text{ V}$ ,  $V_{SS} = EV_{SS0} = EV_{SS1} = 0\text{ V}$ )

(2/2)

Parameter	Symbol	Conditions		MIN.	TYP.	MAX.	Unit		
Supply current Note 1	I <sub>DD2</sub> Note 2	HALT mode	High-speed operation Note 7	f <sub>IH</sub> = 32 MHz <sup>Note 4</sup>	V <sub>DD</sub> = 5.0 V	0.62	2.00	mA	
					V <sub>DD</sub> = 3.0 V	0.62	2.00	mA	
				f <sub>IH</sub> = 24 MHz <sup>Note 4</sup>	V <sub>DD</sub> = 5.0 V	0.50	1.60	mA	
					V <sub>DD</sub> = 3.0 V	0.50	1.60	mA	
				f <sub>IH</sub> = 16 MHz <sup>Note 4</sup>	V <sub>DD</sub> = 5.0 V	0.44	1.25	mA	
					V <sub>DD</sub> = 3.0 V	0.44	1.25	mA	
				Low-speed operation Note 7	f <sub>IH</sub> = 8 MHz <sup>Note 4</sup>	V <sub>DD</sub> = 3.0 V	300	610	μA
					V <sub>DD</sub> = 2.0 V	300	610	μA	
				Low-voltage operation Note 7	f <sub>IH</sub> = 4 MHz <sup>Note 4</sup>	V <sub>DD</sub> = 3.0 V	470	710	μA
					V <sub>DD</sub> = 2.0 V	470	710	μA	
				High-speed operation Note 7	f <sub>MX</sub> = 20 MHz <sup>Note 3</sup> , V <sub>DD</sub> = 5.0 V	Square wave input	0.35	1.30	mA
			Resonator connection			0.45	1.40	mA	
			f <sub>MX</sub> = 20 MHz <sup>Note 3</sup> , V <sub>DD</sub> = 3.0 V		Square wave input	0.35	1.30	mA	
					Resonator connection	0.45	1.40	mA	
			f <sub>MX</sub> = 10 MHz <sup>Note 3</sup> , V <sub>DD</sub> = 5.0 V		Square wave input	0.22	0.72	mA	
					Resonator connection	0.30	0.80	mA	
			f <sub>MX</sub> = 10 MHz <sup>Note 3</sup> , V <sub>DD</sub> = 3.0 V		Square wave input	0.22	0.72	mA	
					Resonator connection	0.30	0.80	mA	
				Low-speed operation Note 7	f <sub>MX</sub> = 8 MHz <sup>Note 3</sup> , V <sub>DD</sub> = 3.0 V	Square wave input	120	480	μA
			Resonator connection			160	520	μA	
			f <sub>MX</sub> = 8 MHz <sup>Note 3</sup> , V <sub>DD</sub> = 2.0 V		Square wave input	120	480	μA	
					Resonator connection	160	520	μA	
				Subsystem clock operation	f <sub>SUB</sub> = 32.768 kHz <sup>Note 5</sup> T <sub>A</sub> = -40°C	Square wave input			μA
			Resonator connection			0.49		μA	
			f <sub>SUB</sub> = 32.768 kHz <sup>Note 5</sup> T <sub>A</sub> = +25°C		Square wave input	0.54		μA	
					Resonator connection			μA	
			f <sub>SUB</sub> = 32.768 kHz <sup>Note 5</sup> T <sub>A</sub> = +50°C		Square wave input			μA	
					Resonator connection			μA	
f <sub>SUB</sub> = 32.768 kHz <sup>Note 5</sup> T <sub>A</sub> = +70°C	Square wave input				μA				
	Resonator connection				μA				
	f <sub>SUB</sub> = 32.768 kHz <sup>Note 5</sup> T <sub>A</sub> = +85°C	Square wave input			μA				
Resonator connection				μA					
	I <sub>DD3</sub> Note 6	STOP mode	T <sub>A</sub> = -40°C			μA			
			T <sub>A</sub> = +25°C		0.25	μA			
			T <sub>A</sub> = +50°C			μA			
			T <sub>A</sub> = +70°C			μA			
			T <sub>A</sub> = +85°C			μA			

**Caution** 128-pin products, and flash ROM: 384 to 512 KB of 44- to 100-pin products, these specifications show target values, which may change after device evaluation.

<R> (Notes and Remarks are listed on the next page.)

**Caution** The pins mounted depend on the product. Refer to 2.1.1 20-pin products to 2.1.14 128-pin products, and 2.1.15 Pins for each product (pins other than port pins).

- Notes**
1. Total current flowing into  $V_{DD}$ ,  $EV_{DD0}$  and  $EV_{DD1}$ , including the input leakage current flowing when the level of the input pin is fixed to  $V_{DD}$ ,  $EV_{DD0}$  or  $V_{SS}$ ,  $EV_{SS0}$ . The values below the MAX. column include the peripheral operation current. However, not including the current flowing into the A/D converter, LVD circuit, I/O port, and on-chip pull-up/pull-down resistors.
  2. During HALT instruction execution by flash memory.
  3. When high-speed on-chip oscillator and subsystem clock are stopped.
  4. When high-speed system clock and subsystem clock are stopped.
  5. When operating real-time clock (RTC) and setting ultra-low current consumption ( $AMPHS1 = 1$ ). When high-speed on-chip oscillator and high-speed system clock are stopped. When watchdog timer is stopped. The values below the MAX. column include the leakage current.
  6. When high-speed on-chip oscillator, high-speed system clock, and subsystem clock are stopped. When watchdog timer is stopped. The values below the MAX. column include the leakage current.
  7. Relationship between operation voltage width, operation frequency of CPU and operation mode is as below.  
 High speed operation:  $V_{DD} = 2.4 \text{ V to } 5.5 \text{ V@1 MHz to } 32 \text{ MHz}$   
 Low speed operation:  $V_{DD} = 1.8 \text{ V to } 5.5 \text{ V@1 MHz to } 8 \text{ MHz}$   
 Low voltage operation:  $V_{DD} = 1.6 \text{ V to } 5.5 \text{ V@1 MHz to } 4 \text{ MHz}$

- Remarks**
1.  $f_{MX}$ : High-speed system clock frequency (X1 clock oscillation frequency or external main system clock frequency)
  2.  $f_{IH}$ : High-speed on-chip oscillator clock frequency
  3.  $f_{SUB}$ : Subsystem clock frequency (XT1 clock oscillation frequency)
  4. Except subsystem clock operation and STOP mode, temperature condition of the TYP. value is  $T_A = 25^\circ\text{C}$

<R>

**Caution** The pins mounted depend on the product. Refer to 2.1.1 20-pin products to 2.1.14 128-pin products, and 2.1.15 Pins for each product (pins other than port pins).

#### (4) Common to RL78/G13 all products

( $T_A = -40$  to  $+85^\circ\text{C}$ ,  $1.6\text{ V} \leq \text{EV}_{\text{DD}0} = \text{EV}_{\text{DD}1} \leq \text{V}_{\text{DD}} \leq 5.5\text{ V}$ ,  $\text{V}_{\text{SS}} = \text{EV}_{\text{SS}0} = \text{EV}_{\text{SS}1} = 0\text{ V}$ )

Parameter	Symbol	Conditions		MIN.	TYP.	MAX.	Unit
RTC operating current	$I_{\text{RTC}}$ <sup>Notes 1, 2</sup>	$f_{\text{SUB}} = 32.768\text{ kHz}$	Real-time clock operation		0.02		$\mu\text{A}$
			Interval timer operation		0.02		
Watchdog timer operating current	$I_{\text{WDT}}$ <sup>Notes 2, 3</sup>	$f_{\text{IL}} = 15\text{ kHz}$			0.22		$\mu\text{A}$
A/D converter operating current	$I_{\text{ADC}}$ <sup>Note 4</sup>	When conversion at maximum speed	Normal mode, $\text{AV}_{\text{REFP}} = \text{V}_{\text{DD}} = 5.0\text{ V}$		1.3	1.7	mA
			Low voltage mode, $\text{AV}_{\text{REFP}} = \text{V}_{\text{DD}} = 3.0\text{ V}$		0.5	0.7	mA
Temperature sensor operating current	$I_{\text{TMPS}}$				75		$\mu\text{A}$
LVD operating current	$I_{\text{LVI}}$ <sup>Note 5</sup>				0.08		$\mu\text{A}$
BGO operating current	$I_{\text{BGO}}$ <sup>Note 6</sup>				2.50	12.20	mA

**Notes** 1. Current flowing only to the real-time clock (excluding the operating current of the XT1 oscillator). The TYP. value of the current value of the RL78/G13 is the sum of the TYP. values of either  $I_{\text{DD}1}$  or  $I_{\text{DD}2}$ , and  $I_{\text{RTC}}$ , when the real-time clock operates in operation mode or HALT mode. The  $I_{\text{DD}1}$  and  $I_{\text{DD}2}$  MAX. values also include the real-time clock operating current. However,  $I_{\text{DD}2}$  subsystem clock operation includes the operational current of the real-time clock.

<R>

- When high speed on-chip oscillator and high-speed system clock are stopped.
- Current flowing only to the watchdog timer (including the operating current of the low-speed on-chip oscillator). The current value of the RL78/G13 is the sum of  $I_{\text{DD}1}$ ,  $I_{\text{DD}2}$  or  $I_{\text{DD}3}$  and  $I_{\text{WDT}}$  when  $f_{\text{CLK}} = f_{\text{SUB}}$  when the watchdog timer operates in STOP mode.
- Current flowing only to the A/D converter. The current value of the RL78/G13 is the sum of  $I_{\text{DD}1}$  or  $I_{\text{DD}2}$  and  $I_{\text{ADC}}$  when the A/D converter operates in an operation mode or the HALT mode.
- Current flowing only to the LVD circuit. The current value of the RL78/G13 is the sum of  $I_{\text{DD}1}$ ,  $I_{\text{DD}2}$  or  $I_{\text{DD}3}$  and  $I_{\text{LVI}}$  when the LVD circuit operates in the Operating, HALT or STOP mode.
- Current flowing only to the BGO. The current value of the RL78/G13 is the sum of  $I_{\text{DD}1}$  or  $I_{\text{DD}2}$  and  $I_{\text{BGO}}$  when the BGO operates in an operation mode.

- Remarks**
- $f_{\text{IL}}$ : Low-speed on-chip oscillator clock frequency
  - $f_{\text{SUB}}$ : Subsystem clock frequency (XT1 clock oscillation frequency)
  - $f_{\text{CLK}}$ : CPU/peripheral hardware clock frequency
  - Temperature condition of the TYP. value is  $T_A = 25^\circ\text{C}$



**Caution** The pins mounted depend on the product. Refer to 2.1.1 20-pin products to 2.1.14 128-pin products, and 2.1.15 Pins for each product (pins other than port pins).

## 29.5 AC Characteristics

### 29.5.1 Basic operation

( $T_A = -40$  to  $+85^\circ\text{C}$ ,  $1.6\text{ V} \leq EV_{DD0} = EV_{DD1} \leq V_{DD} \leq 5.5\text{ V}$ ,  $V_{SS} = EV_{SS0} = EV_{SS1} = 0\text{ V}$ )

Items	Symbol	Conditions		MIN.	TYP.	MAX.	Unit	
Instruction cycle (minimum instruction execution time)	$T_{CY}$	Main system clock ( $f_{MAIN}$ ) operation	High-speed main mode	$2.7\text{ V} \leq V_{DD} \leq 5.5\text{ V}$	0.03125		1	$\mu\text{S}$
				$2.4\text{ V} \leq V_{DD} < 2.7\text{ V}$	0.0625		1	$\mu\text{S}$
			Low voltage main mode	$1.6\text{ V} \leq V_{DD} \leq 5.5\text{ V}$	0.25		1	$\mu\text{S}$
			Low-speed main mode	$1.8\text{ V} \leq V_{DD} \leq 5.5\text{ V}$	0.125		1	$\mu\text{S}$
		Subsystem clock ( $f_{SUB}$ ) operation		$1.8\text{ V} \leq V_{DD} \leq 5.5\text{ V}$	28.5	30.5	31.3	$\mu\text{S}$
		In the self programming mode	High-speed main mode	$2.7\text{ V} \leq V_{DD} \leq 5.5\text{ V}$	0.03125		1	$\mu\text{S}$
				$2.4\text{ V} \leq V_{DD} < 2.7\text{ V}$	0.0625		1	$\mu\text{S}$
			Low voltage main mode	$1.8\text{ V} \leq V_{DD} \leq 5.5\text{ V}$	0.25		1	$\mu\text{S}$
			Low-speed main mode	$1.8\text{ V} \leq V_{DD} \leq 5.5\text{ V}$	0.125		1	$\mu\text{S}$
		External main system clock frequency	$f_{EX}$	$2.7\text{ V} \leq V_{DD} \leq 5.5\text{ V}$		1.0		20.0
$1.8\text{ V} \leq V_{DD} < 2.7\text{ V}$				1.0		8.0	MHz	
$1.6\text{ V} \leq V_{DD} < 1.8\text{ V}$				1.0		4.0	MHz	
$f_{EXS}$				32		35	kHz	
External main system clock input high-level width, low-level width	$t_{EXH}, t_{EXL}$	$2.7\text{ V} \leq V_{DD} \leq 5.5\text{ V}$		24			ns	
		$1.8\text{ V} \leq V_{DD} < 2.7\text{ V}$		60			ns	
		$1.6\text{ V} \leq V_{DD} < 1.8\text{ V}$		120			ns	
	$t_{EXHS}, t_{EXLS}$			13.7			$\mu\text{S}$	
<R> TI00 to TI07, TI10 to TI17 input high-level width, low-level width	$t_{TIH}, t_{TIL}$			$1/f_{MCK}+10$			ns <sup>Note</sup>	
<R> TO00 to TO07, TO10 to TO17 output frequency	$f_{TO}$	High-speed main mode	$4.0\text{ V} \leq EV_{DD0} \leq 5.5\text{ V}$			16	MHz	
			$2.7\text{ V} \leq EV_{DD0} < 4.0\text{ V}$			8	MHz	
			$1.8\text{ V} \leq EV_{DD0} < 2.7\text{ V}$			4	MHz	
			$1.6\text{ V} \leq EV_{DD0} < 1.8\text{ V}$			2	MHz	
		Low voltage main mode	$1.6\text{ V} \leq EV_{DD0} \leq 5.5\text{ V}$			2	MHz	
		Low-speed main mode	$1.8\text{ V} \leq EV_{DD0} \leq 5.5\text{ V}$			4	MHz	
$1.6\text{ V} \leq EV_{DD0} < 1.8\text{ V}$			2	MHz				
<R> PCLBUZ0, PCLBUZ1 output frequency	$f_{PCL}$	High-speed main mode	$4.0\text{ V} \leq EV_{DD0} \leq 5.5\text{ V}$			16	MHz	
			$2.7\text{ V} \leq EV_{DD0} < 4.0\text{ V}$			8	MHz	
			$1.8\text{ V} \leq EV_{DD0} < 2.7\text{ V}$			4	MHz	
			$1.6\text{ V} \leq EV_{DD0} < 1.8\text{ V}$			2	MHz	
		Low voltage main mode	$1.8\text{ V} \leq EV_{DD0} \leq 5.5\text{ V}$			4	MHz	
		$1.6\text{ V} \leq EV_{DD0} < 1.8\text{ V}$			2	MHz		
<R> Interrupt input high-level width, low-level width	$t_{INTH}, t_{INTL}$	INTP0	$1.6\text{ V} \leq V_{DD} \leq 5.5\text{ V}$	1			$\mu\text{S}$	
		INTP1 to INTP11	$1.6\text{ V} \leq EV_{DD0} \leq 5.5\text{ V}$	1			$\mu\text{S}$	
<R> Key interrupt input low-level width	$t_{KR}$	KR0 to KR7	$1.8\text{ V} \leq EV_{DD0} \leq 5.5\text{ V}$	250			ns	
			$1.6\text{ V} \leq EV_{DD0} < 1.8\text{ V}$	1			$\mu\text{S}$	
RESET low-level width	$t_{RSL}$			10			$\mu\text{S}$	

(Note and Remark are listed on the next page.)

**Caution** The pins mounted depend on the product. Refer to 2.1.1 20-pin products to 2.1.14 128-pin products, and 2.1.15 Pins for each product (pins other than port pins).

**Note** The following conditions are required for low voltage interface when  $E_{VDD0} < V_{DD}$

1.8 V  $\leq$   $E_{VDD0} < 2.7$  V : MIN. 125 ns

1.6 V  $\leq$   $E_{VDD0} < 1.8$  V : MIN. 250 ns

**Remark**  $f_{MCK}$ : Timer array unit operation clock frequency

(Operation clock to be set by the CKS0n bit of timer mode register 0n (TMR0n). n: Channel number (n = 0 to 7))

**Caution** The pins mounted depend on the product. Refer to 2.1.1 20-pin products to 2.1.14 128-pin products, and 2.1.15 Pins for each product (pins other than port pins).

### 29.6 Peripheral Functions Characteristics

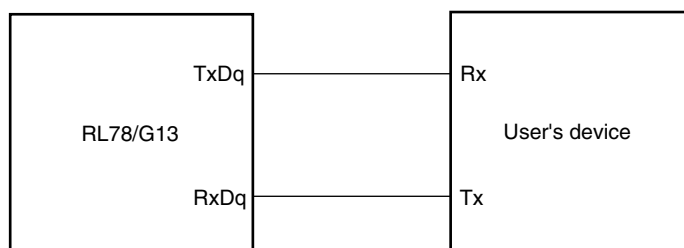
#### 29.6.1 Serial array unit

(1) During communication at same potential (UART mode) (dedicated baud rate generator output)

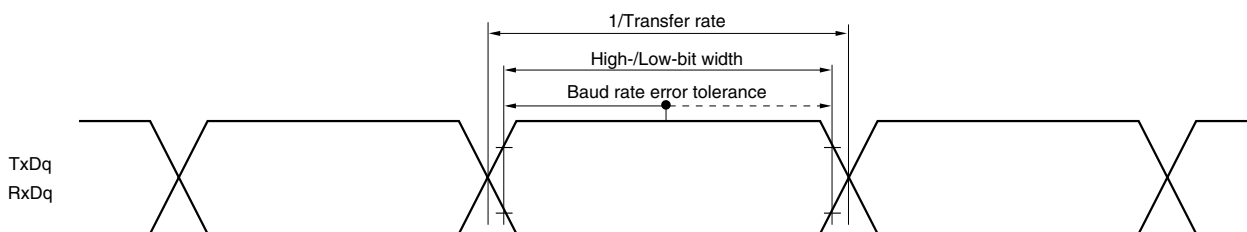
( $T_A = -40$  to  $+85^\circ\text{C}$ ,  $1.6\text{ V} \leq EV_{DD0} = EV_{DD1} \leq V_{DD} \leq 5.5\text{ V}$ ,  $V_{SS} = EV_{SS0} = EV_{SS1} = 0\text{ V}$ )

Parameter	Symbol	Conditions	MIN.	TYP.	MAX.	Unit
<R> Transfer rate <sup>Note 1</sup>		Theoretical value of the maximum transfer rate $f_{CLK} = 32\text{ MHz}$ , $f_{MCK} = f_{CLK}$			$f_{MCK}/6$ <sup>Note 2</sup>	bps
					5.3	Mbps

**UART mode connection diagram (during communication at same potential)**



**UART mode bit width (during communication at same potential) (reference)**



**Notes 1.** Transfer rate in the SNOOZE mode is max. 9600 bps, min. 4800 bps.

<R> **2.** The following conditions are required for low voltage interface when  $EV_{DD0} < V_{DD}$ .

$2.4\text{ V} \leq EV_{DD0} < 2.7\text{ V}$  : MAX. 2.6 Mbps

$1.8\text{ V} \leq EV_{DD0} < 2.4\text{ V}$  : MAX. 1.3 Mbps

$1.6\text{ V} \leq EV_{DD0} < 1.8\text{ V}$  : MAX. 0.6 Mbps

**Caution** Select the normal input buffer for the RxDq pin and the normal output mode for the TxDq pin by using port input mode register g (PIMg) and port output mode register g (POMg).

**Remarks 1.** q: UART number (q = 0 to 3), g: PIM and POM number (g = 0, 1, 8, 14)

**2.**  $f_{MCK}$ : Serial array unit operation clock frequency

(Operation clock to be set by the CKSmn bit of serial mode register mn (SMRmn). m: Unit number, n: Channel number (mn = 00 to 03, 10 to 13))

**Caution** The pins mounted depend on the product. Refer to 2.1.1 20-pin products to 2.1.14 128-pin products, and 2.1.15 Pins for each product (pins other than port pins).

(2) During communication at same potential (CSI mode) (master mode ( $f_{MCK}/2$ ),  $\overline{SCKp}$ ... internal clock output)  
( $T_A = -40$  to  $+85^\circ\text{C}$ ,  $2.7\text{ V} \leq EV_{DD0} = EV_{DD1} \leq V_{DD} \leq 5.5\text{ V}$ ,  $V_{SS} = EV_{SS0} = EV_{SS1} = 0\text{ V}$ )

Parameter	Symbol	Conditions	MIN.	TYP.	MAX.	Unit
$\overline{SCKp}$ cycle time	$t_{KCY1}$	$2.7\text{ V} \leq EV_{DD0} \leq 5.5\text{ V}$	62.5 <sup>Note 1</sup>			ns
$\overline{SCKp}$ high-/low-level width	$t_{KH1}$ , $t_{KL1}$	$4.0\text{ V} \leq EV_{DD0} \leq 5.5\text{ V}$	$t_{KCY1}/2 - 7$			ns
		$2.7\text{ V} \leq EV_{DD0} \leq 5.5\text{ V}$	$t_{KCY1}/2 - 10$			ns
<R> Slp setup time (to $\overline{SCKp}\uparrow$ ) <sup>Note 2</sup>	$t_{SIK1}$	$4.0\text{ V} \leq EV_{DD0} \leq 5.5\text{ V}$	23			ns
		$2.7\text{ V} \leq EV_{DD0} \leq 5.5\text{ V}$	33 <sup>Note 5</sup>			ns
Slp hold time (from $\overline{SCKp}\uparrow$ ) <sup>Note 3</sup>	$t_{KSI1}$	$2.7\text{ V} \leq EV_{DD0} \leq 5.5\text{ V}$	10			ns
Delay time from $\overline{SCKp}\downarrow$ to SOp output <sup>Note 4</sup>	$t_{KSO1}$	$C = 20\text{ pF}$ <sup>Note 6</sup>			10	ns

**Notes** 1. The value must also be  $2/f_{CLK}$  or more.

2. When  $DAPmn = 0$  and  $CKPmn = 0$ , or  $DAPmn = 1$  and  $CKPmn = 1$ . The Slp setup time becomes “to  $\overline{SCKp}\downarrow$ ” when  $DAPmn = 0$  and  $CKPmn = 1$ , or  $DAPmn = 1$  and  $CKPmn = 0$ .

3. When  $DAPmn = 0$  and  $CKPmn = 0$ , or  $DAPmn = 1$  and  $CKPmn = 1$ . The Slp hold time becomes “from  $\overline{SCKp}\downarrow$ ” when  $DAPmn = 0$  and  $CKPmn = 1$ , or  $DAPmn = 1$  and  $CKPmn = 0$ .

4. When  $DAPmn = 0$  and  $CKPmn = 0$ , or  $DAPmn = 1$  and  $CKPmn = 1$ . The delay time to SOp output becomes “from  $\overline{SCKp}\uparrow$ ” when  $DAPmn = 0$  and  $CKPmn = 1$ , or  $DAPmn = 1$  and  $CKPmn = 0$ .

<R> 5. Using the  $f_{MCK}$  within 24 MHz.

6. C is the load capacitance of the  $\overline{SCKp}$  and SOp output lines.

**Caution** Select the normal input buffer for the Slp pin and the normal output mode for the SOp pin and  $\overline{SCKp}$  pin by using port input mode register g (PIMg) and port output mode register g (POMg).

**Remarks** 1. This specification is valid only when CSI00's peripheral I/O redirect function is not used.

2. p: CSI number (p = 00), m: Unit number (m = 0), n: Channel number (n = 0),  
g: PIM and POM numbers (g = 1)

3.  $f_{MCK}$ : Serial array unit operation clock frequency  
(Operation clock to be set by the CKSmn bit of serial mode register mn (SMRmn). m: Unit number,  
n: Channel number (mn = 00))

**Caution** The pins mounted depend on the product. Refer to 2.1.1 20-pin products to 2.1.14 128-pin products, and 2.1.15 Pins for each product (pins other than port pins).

**(3) During communication at same potential (CSI mode) (master mode ( $f_{MCK}/4$ ),  $\overline{SCKp}$ ... internal clock output)**  
( $T_A = -40$  to  $+85^\circ\text{C}$ ,  $1.6\text{ V} \leq EV_{DD0} = EV_{DD1} \leq V_{DD} \leq 5.5\text{ V}$ ,  $V_{SS} = EV_{SS0} = EV_{SS1} = 0\text{ V}$ )

Parameter	Symbol	Conditions	MIN.	TYP.	MAX.	Unit
$\overline{SCKp}$ cycle time	$t_{CY1}$	$2.7\text{ V} \leq EV_{DD0} \leq 5.5\text{ V}$	125 <sup>Note 1</sup>			ns
		$2.4\text{ V} \leq EV_{DD0} \leq 5.5\text{ V}$	250 <sup>Note 1</sup>			ns
		$1.8\text{ V} \leq EV_{DD0} \leq 5.5\text{ V}$	500 <sup>Note 1</sup>			ns
		$1.6\text{ V} \leq EV_{DD0} \leq 5.5\text{ V}$	1000 <sup>Note 1</sup>			ns
$\overline{SCKp}$ high-/low-level width	$t_{KH1}$ , $t_{KL1}$	$4.0\text{ V} \leq EV_{DD0} \leq 5.5\text{ V}$	$t_{CY1}/2 - 12$			ns
		$2.7\text{ V} \leq EV_{DD0} \leq 5.5\text{ V}$	$t_{CY1}/2 - 18$			ns
		$2.4\text{ V} \leq EV_{DD0} \leq 5.5\text{ V}$	$t_{CY1}/2 - 38$			ns
		$1.8\text{ V} \leq EV_{DD0} \leq 5.5\text{ V}$	$t_{CY1}/2 - 50$			ns
		$1.6\text{ V} \leq EV_{DD0} \leq 5.5\text{ V}$	$t_{CY1}/2 - 100$			ns
<R> Slp setup time (to $\overline{SCKp}\uparrow$ ) <sup>Note 2</sup>	$t_{SIK1}$	$4.0\text{ V} \leq EV_{DD0} \leq 5.5\text{ V}$	44			ns
		$2.7\text{ V} \leq EV_{DD0} \leq 5.5\text{ V}$	44			ns
		$2.4\text{ V} \leq EV_{DD0} \leq 5.5\text{ V}$	75			ns
		$1.8\text{ V} \leq EV_{DD0} \leq 5.5\text{ V}$	110			ns
		$1.6\text{ V} \leq EV_{DD0} \leq 5.5\text{ V}$	220			ns
Slp hold time (from $\overline{SCKp}\uparrow$ ) <sup>Note 3</sup>	$t_{SH1}$		19			ns
Delay time from $\overline{SCKp}\downarrow$ to SOp output <sup>Note 4</sup>	$t_{SO1}$	$C = 30\text{ pF}$ <sup>Note 5</sup>			25	ns

**Notes** 1. The value must also be  $4/f_{CLK}$  or more.

- When  $DAPmn = 0$  and  $CKPmn = 0$ , or  $DAPmn = 1$  and  $CKPmn = 1$ . The Slp setup time becomes “to  $\overline{SCKp}\downarrow$ ” when  $DAPmn = 0$  and  $CKPmn = 1$ , or  $DAPmn = 1$  and  $CKPmn = 0$ .
- When  $DAPmn = 0$  and  $CKPmn = 0$ , or  $DAPmn = 1$  and  $CKPmn = 1$ . The Slp hold time becomes “from  $\overline{SCKp}\downarrow$ ” when  $DAPmn = 0$  and  $CKPmn = 1$ , or  $DAPmn = 1$  and  $CKPmn = 0$ .
- When  $DAPmn = 0$  and  $CKPmn = 0$ , or  $DAPmn = 1$  and  $CKPmn = 1$ . The delay time to SOp output becomes “from  $\overline{SCKp}\uparrow$ ” when  $DAPmn = 0$  and  $CKPmn = 1$ , or  $DAPmn = 1$  and  $CKPmn = 0$ .
- C is the load capacitance of the  $\overline{SCKp}$  and SOp output lines.

**Caution** Select the normal input buffer for the Slp pin and the normal output mode for the SOp pin and  $\overline{SCKp}$  pin by using port input mode register g (PIMg) and port output mode register g (POMg).

**Remarks** 1. This specification is valid only when CSI00's peripheral I/O redirect function is not used.

- p: CSI number (p = 00, 01, 10, 11, 20, 21, 30, 31), m: Unit number (m = 0, 1), n: Channel number (n = 0 to 3), g: PIM and POM numbers (g = 0, 1, 4, 5, 8, 14)
- $f_{MCK}$ : Serial array unit operation clock frequency  
(Operation clock to be set by the CKSmn bit of serial mode register mn (SMRmn). m: Unit number, n: Channel number (mn = 00 to 03, 10 to 13))

**Caution** The pins mounted depend on the product. Refer to 2.1.1 20-pin products to 2.1.14 128-pin products, and 2.1.15 Pins for each product (pins other than port pins).

**(4) During communication at same potential (CSI mode) (slave mode,  $\overline{\text{SCKp}}$ ... external clock input)**

( $T_A = -40$  to  $+85^\circ\text{C}$ ,  $1.6\text{ V} \leq \text{EV}_{\text{DD0}} = \text{EV}_{\text{DD1}} \leq \text{V}_{\text{DD}} \leq 5.5\text{ V}$ ,  $\text{V}_{\text{SS}} = \text{EV}_{\text{SS0}} = \text{EV}_{\text{SS1}} = 0\text{ V}$ )

Parameter	Symbol	Conditions		MIN.	TYP.	MAX.	Unit
<R> $\overline{\text{SCKp}}$ cycle time <sup>Note 5</sup>	$t_{\text{CY2}}$	$4.0\text{ V} \leq \text{EV}_{\text{DD0}} \leq 5.5\text{ V}$	$20\text{ MHz} < f_{\text{MCK}}$	$8/f_{\text{MCK}}$			ns
			$f_{\text{MCK}} \leq 20\text{ MHz}$	$6/f_{\text{MCK}}$			ns
		$2.7\text{ V} \leq \text{EV}_{\text{DD0}} < 4.0\text{ V}$	$16\text{ MHz} < f_{\text{MCK}}$	$8/f_{\text{MCK}}$			ns
			$f_{\text{MCK}} \leq 16\text{ MHz}$	$6/f_{\text{MCK}}$			ns
		$1.8\text{ V} \leq \text{EV}_{\text{DD0}} < 2.7\text{ V}$	$16\text{ MHz} < f_{\text{MCK}}$	$8/f_{\text{MCK}}$			ns
			$f_{\text{MCK}} \leq 16\text{ MHz}$	$6/f_{\text{MCK}}$			ns
		$1.6\text{ V} \leq \text{EV}_{\text{DD0}} < 1.8\text{ V}$		$6/f_{\text{MCK}}$			ns
$\overline{\text{SCKp}}$ high-/low-level width	$t_{\text{KH2}}$ , $t_{\text{KL2}}$	$1.6\text{ V} \leq \text{EV}_{\text{DD0}} \leq 5.5\text{ V}$		$t_{\text{CY2}}/2$			ns
<R> Slp setup time (to $\overline{\text{SCKp}}\uparrow$ ) <sup>Note 1</sup>	$t_{\text{SIK2}}$	$2.7\text{ V} \leq \text{EV}_{\text{DD0}} \leq 5.5\text{ V}$		$1/f_{\text{MCK}}+20$			ns
		$1.8\text{ V} \leq \text{EV}_{\text{DD0}} < 2.7\text{ V}$		$1/f_{\text{MCK}}+30$			ns
		$1.6\text{ V} \leq \text{EV}_{\text{DD0}} < 1.8\text{ V}$		$1/f_{\text{MCK}}+40$			ns
<R> Slp hold time (from $\overline{\text{SCKp}}\uparrow$ ) <sup>Note 2</sup>	$t_{\text{SIS2}}$	$2.7\text{ V} \leq \text{EV}_{\text{DD0}} \leq 5.5\text{ V}$		$1/f_{\text{MCK}}+31$			ns
		$1.8\text{ V} \leq \text{EV}_{\text{DD0}} < 2.7\text{ V}$		$1/f_{\text{MCK}}+31$			ns
		$1.6\text{ V} \leq \text{EV}_{\text{DD0}} < 1.8\text{ V}$		$1/f_{\text{MCK}}+$ 250			ns
<R> Delay time from $\overline{\text{SCKp}}\downarrow$ to SOp output <sup>Note 3</sup>	$t_{\text{SOS2}}$	$C = 30\text{ pF}$ <sup>Note 4</sup>	$4.0\text{ V} \leq \text{EV}_{\text{DD0}} \leq 5.5\text{ V}$			$2/f_{\text{MCK}}+44$	ns
			$2.7\text{ V} \leq \text{EV}_{\text{DD0}} < 4.0\text{ V}$			$2/f_{\text{MCK}}+44$	ns
			$2.4\text{ V} \leq \text{EV}_{\text{DD0}} < 2.7\text{ V}$			$2/f_{\text{MCK}}+75$	ns
			$1.8\text{ V} \leq \text{EV}_{\text{DD0}} < 2.4\text{ V}$			$2/f_{\text{MCK}}+110$	ns
			$1.6\text{ V} \leq \text{EV}_{\text{DD0}} < 1.8\text{ V}$			$2/f_{\text{MCK}}+220$	ns

**Notes** 1. When  $\text{DAPmn} = 0$  and  $\text{CKPmn} = 0$ , or  $\text{DAPmn} = 1$  and  $\text{CKPmn} = 1$ . The Slp setup time becomes “to  $\overline{\text{SCKp}}\downarrow$ ” when  $\text{DAPmn} = 0$  and  $\text{CKPmn} = 1$ , or  $\text{DAPmn} = 1$  and  $\text{CKPmn} = 0$ .

2. When  $\text{DAPmn} = 0$  and  $\text{CKPmn} = 0$ , or  $\text{DAPmn} = 1$  and  $\text{CKPmn} = 1$ . The Slp hold time becomes “from  $\overline{\text{SCKp}}\downarrow$ ” when  $\text{DAPmn} = 0$  and  $\text{CKPmn} = 1$ , or  $\text{DAPmn} = 1$  and  $\text{CKPmn} = 0$ .

3. When  $\text{DAPmn} = 0$  and  $\text{CKPmn} = 0$ , or  $\text{DAPmn} = 1$  and  $\text{CKPmn} = 1$ . The delay time to SOp output becomes “from  $\overline{\text{SCKp}}\uparrow$ ” when  $\text{DAPmn} = 0$  and  $\text{CKPmn} = 1$ , or  $\text{DAPmn} = 1$  and  $\text{CKPmn} = 0$ .

4. C is the load capacitance of the SOp output lines.

<R> 5. Transfer rate in the SNOOZE mode : MAX. 1 Mbps

**Caution** Select the TTL input buffer for the Slp pin and  $\overline{\text{SCKp}}$  pin and the normal output mode for the SOp pin by using port input mode register g (PIMg) and port output mode register g (POMg).

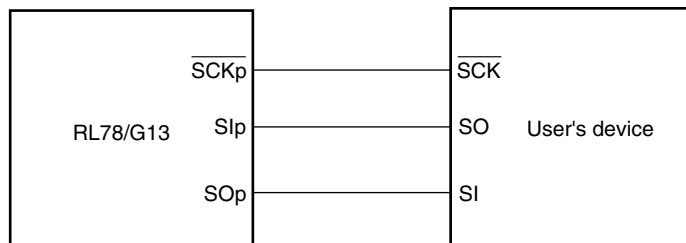
**Remarks** 1. p: CSI number (p = 00, 01, 10, 11, 20, 21, 30, 31), m: Unit number (m = 0, 1),  
n: Channel number (n = 0 to 3), g: PIM number (g = 0, 1, 4, 5, 8, 14)

2.  $f_{\text{MCK}}$ : Serial array unit operation clock frequency

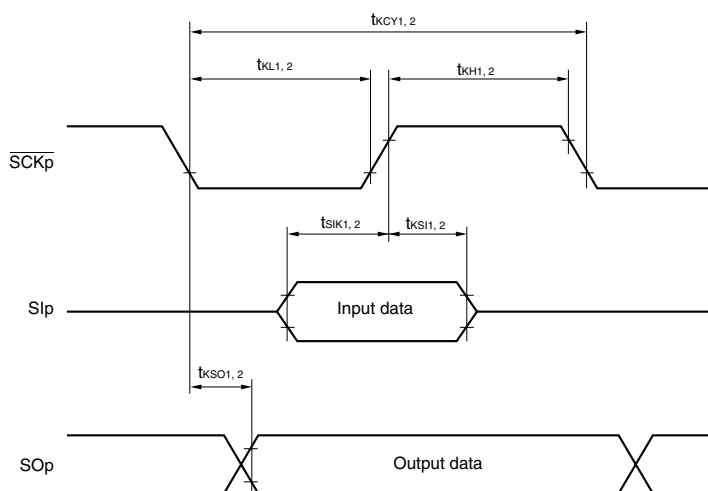
(Operation clock to be set by the CKSmn bit of serial mode register mn (SMRmn). m: Unit number, n: Channel number (mn = 00 to 03, 10 to 13))

**Caution** The pins mounted depend on the product. Refer to 2.1.1 20-pin products to 2.1.14 128-pin products, and 2.1.15 Pins for each product (pins other than port pins).

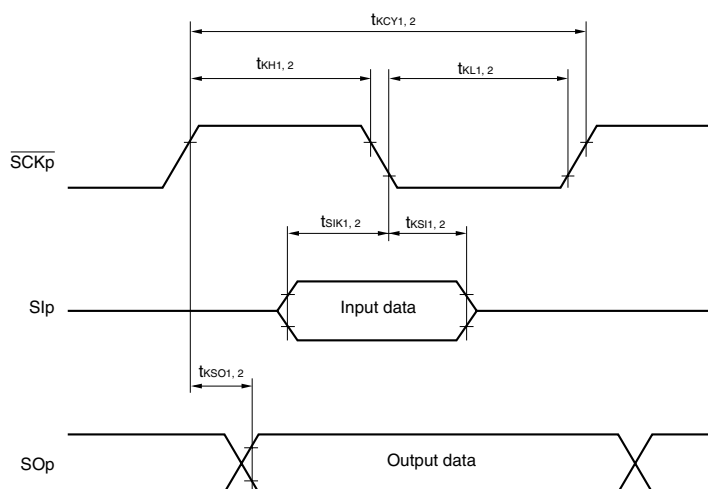
**CSI mode connection diagram (during communication at same potential)**



**CSI mode serial transfer timing (during communication at same potential)**  
 (When DAPmn = 0 and CKPmn = 0, or DAPmn = 1 and CKPmn = 1.)



**CSI mode serial transfer timing (during communication at same potential)**  
 (When DAPmn = 0 and CKPmn = 1, or DAPmn = 1 and CKPmn = 0.)



- Remarks 1.** p: CSI number (p = 00, 01, 10, 11, 20, 21, 30, 31)
- 2.** m: Unit number, n: Channel number (mn = 00 to 03, 10 to 13)

**Caution** The pins mounted depend on the product. Refer to 2.1.1 20-pin products to 2.1.14 128-pin products, and 2.1.15 Pins for each product (pins other than port pins).

(5) During communication at same potential (simplified I<sup>2</sup>C mode)

(T<sub>A</sub> = -40 to +85°C, 1.6 V ≤ EV<sub>DD0</sub> = EV<sub>DD1</sub> ≤ V<sub>DD</sub> ≤ 5.5 V, V<sub>SS</sub> = EV<sub>SS0</sub> = EV<sub>SS1</sub> = 0 V)

Parameter	Symbol	Conditions	MIN.	MAX.	Unit
SCLr clock frequency	f <sub>SCL</sub>	2.7 V ≤ EV <sub>DD0</sub> ≤ 5.5 V, C <sub>b</sub> = 50 pF, R <sub>b</sub> = 2.7 kΩ		1000	kHz
		1.8 V ≤ EV <sub>DD0</sub> ≤ 5.5 V, C <sub>b</sub> = 100 pF, R <sub>b</sub> = 3 kΩ		400	kHz
		1.8 V ≤ EV <sub>DD0</sub> < 2.7 V, C <sub>b</sub> = 100 pF, R <sub>b</sub> = 5 kΩ		300	kHz
		1.6 V ≤ EV <sub>DD0</sub> < 1.8 V, C <sub>b</sub> = 100 pF, R <sub>b</sub> = 5 kΩ		250	kHz
Hold time when SCLr = "L"	t <sub>LOW</sub>	2.7 V ≤ EV <sub>DD0</sub> ≤ 5.5 V, C <sub>b</sub> = 50 pF, R <sub>b</sub> = 2.7 kΩ	475		ns
		1.8 V ≤ EV <sub>DD0</sub> ≤ 5.5 V, C <sub>b</sub> = 100 pF, R <sub>b</sub> = 3 kΩ	1150		ns
		1.8 V ≤ EV <sub>DD0</sub> < 2.7 V, C <sub>b</sub> = 100 pF, R <sub>b</sub> = 5 kΩ	1550		ns
		1.6 V ≤ EV <sub>DD0</sub> < 1.8 V, C <sub>b</sub> = 100 pF, R <sub>b</sub> = 5 kΩ	1850		ns
Hold time when SCLr = "H"	t <sub>HIGH</sub>	2.7 V ≤ EV <sub>DD0</sub> ≤ 5.5 V, C <sub>b</sub> = 50 pF, R <sub>b</sub> = 2.7 kΩ	475		ns
		1.8 V ≤ EV <sub>DD0</sub> ≤ 5.5 V, C <sub>b</sub> = 100 pF, R <sub>b</sub> = 3 kΩ	1150		ns
		1.8 V ≤ EV <sub>DD0</sub> < 2.7 V, C <sub>b</sub> = 100 pF, R <sub>b</sub> = 5 kΩ	1550		ns
		1.6 V ≤ EV <sub>DD0</sub> < 1.8 V, C <sub>b</sub> = 100 pF, R <sub>b</sub> = 5 kΩ	1850		ns
Data setup time (reception)	t <sub>SU:DAT</sub>	2.7 V ≤ EV <sub>DD0</sub> ≤ 5.5 V, C <sub>b</sub> = 50 pF, R <sub>b</sub> = 2.7 kΩ	1/f <sub>MCK</sub> + 85 <small>Note</small>		ns
		1.8 V ≤ EV <sub>DD0</sub> ≤ 5.5 V, C <sub>b</sub> = 100 pF, R <sub>b</sub> = 3 kΩ	1/f <sub>MCK</sub> + 145 <small>Note</small>		ns
		1.8 V ≤ EV <sub>DD0</sub> < 2.7 V, C <sub>b</sub> = 100 pF, R <sub>b</sub> = 5 kΩ	1/f <sub>MCK</sub> + 230 <small>Note</small>		ns
		1.6 V ≤ EV <sub>DD0</sub> < 1.8 V, C <sub>b</sub> = 100 pF, R <sub>b</sub> = 5 kΩ	1/f <sub>MCK</sub> + 290 <small>Note</small>		ns
Data hold time (transmission)	t <sub>HD:DAT</sub>	2.7 V ≤ EV <sub>DD0</sub> ≤ 5.5 V, C <sub>b</sub> = 50 pF, R <sub>b</sub> = 2.7 kΩ	0	305	ns
		1.8 V ≤ EV <sub>DD0</sub> ≤ 5.5 V, C <sub>b</sub> = 100 pF, R <sub>b</sub> = 3 kΩ	0	355	ns
		1.8 V ≤ EV <sub>DD0</sub> < 2.7 V, C <sub>b</sub> = 100 pF, R <sub>b</sub> = 5 kΩ	0	405	ns
		1.6 V ≤ EV <sub>DD0</sub> < 1.8 V, C <sub>b</sub> = 100 pF, R <sub>b</sub> = 5 kΩ	0	405	ns

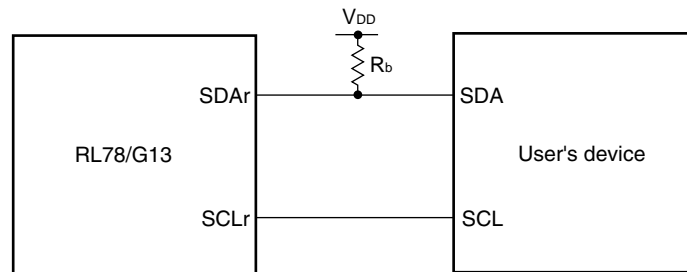
<R> **Note** Set the f<sub>MCK</sub> value to keep the hold time of SCLr = "L" and SCLr = "H".

(**Caution** and **Remarks** are listed on the next page.)

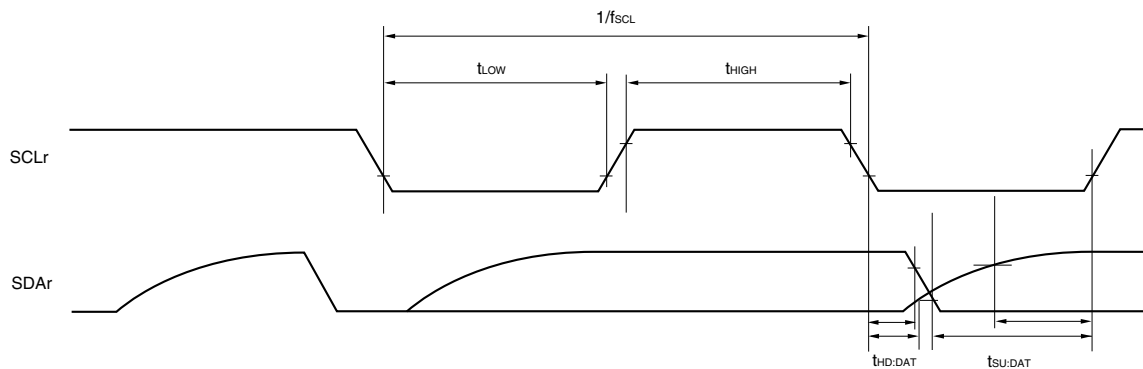


**Caution** The pins mounted depend on the product. Refer to 2.1.1 20-pin products to 2.1.14 128-pin products, and 2.1.15 Pins for each product (pins other than port pins).

**Simplified I<sup>2</sup>C mode connection diagram (during communication at same potential)**



**Simplified I<sup>2</sup>C mode serial transfer timing (during communication at same potential)**



**Caution** Select the TTL input buffer and the N-ch open drain output (V<sub>DD</sub> tolerance) mode for the SDAr pin and the normal output mode for the SCLr pin by using port input mode register g (PIMg) and port output mode register h (POMh).

- Remarks**
1. R<sub>b</sub>[Ω]: Communication line (SDAr) pull-up resistance, C<sub>b</sub>[F]: Communication line (SDAr, SCLr) load capacitance
  2. r: IIC number (r = 00, 01, 10, 11, 20, 21, 30, 31), g: PIM number (g = 0, 1, 4, 5, 8, 14), h: POM number (g = 0, 1, 4, 5, 7 to 9, 14)
  3. f<sub>MCK</sub>: Serial array unit operation clock frequency (Operation clock to be set by the CKSmn bit of serial mode register mn (SMRmn). m: Unit number (m = 0, 1), n: Channel number (n = 0 to 3), mn = 00 to 03, 10 to 13)

**Caution** The pins mounted depend on the product. Refer to 2.1.1 20-pin products to 2.1.14 128-pin products, and 2.1.15 Pins for each product (pins other than port pins).

**(6) Communication at different potential (2.5 V, 3 V) (UART mode) (dedicated baud rate generator output) (1/2)**  
**( $T_A = -40$  to  $+85^\circ\text{C}$ ,  $1.8\text{ V} \leq EV_{DD0} = EV_{DD1} \leq V_{DD} \leq 5.5\text{ V}$ ,  $V_{SS} = EV_{SS0} = EV_{SS1} = 0\text{ V}$ )**

Parameter	Symbol	Conditions	MIN.	TYP.	MAX.	Unit
Transfer rate	reception	$4.0\text{ V} \leq EV_{DD0} \leq 5.5\text{ V}$ , $2.7\text{ V} \leq V_b \leq 4.0\text{ V}$			$f_{MCK}/6$ <sup>Note 1</sup>	bps
			Theoretical value of the maximum transfer rate $f_{CLK} = 32\text{ MHz}$ , $f_{MCK} = f_{CLK}$		5.3	Mbps
		$2.7\text{ V} \leq EV_{DD0} < 4.0\text{ V}$ , $2.3\text{ V} \leq V_b \leq 2.7\text{ V}$			$f_{MCK}/6$ <sup>Note 1</sup>	bps
			Theoretical value of the maximum transfer rate $f_{CLK} = 32\text{ MHz}$ , $f_{MCK} = f_{CLK}$		5.3	Mbps
		$1.8\text{ V} \leq EV_{DD0} < 3.3\text{ V}$ , $1.6\text{ V} \leq V_b \leq 2.0\text{ V}$			$f_{MCK}/6$ Notes 1 to 3	bps
			Theoretical value of the maximum transfer rate $f_{CLK} = 8\text{ MHz}$ , $f_{MCK} = f_{CLK}$		1.3	Mbps

<R> **Notes 1.** Transfer rate in the SNOOZE mode : MAX. 9600 bps, MIN. 4800 bps

<R> **2.** Use it with  $EV_{DD0} \geq V_b$ .

<R> **3.** The following conditions are required for low voltage interface when  $EV_{DD0} < V_{DD}$ .

$2.4\text{ V} \leq EV_{DD0} < 2.7\text{ V}$  : MAX. 2.6 Mbps

$1.8\text{ V} \leq EV_{DD0} < 2.4\text{ V}$  : MAX. 1.3 Mbps

$1.6\text{ V} \leq EV_{DD0} < 1.8\text{ V}$  : MAX. 0.6 Mbps

**Caution** Select the TTL input buffer for the RxDq pin and the N-ch open drain output ( $V_{DD}$  tolerance) mode for the TxDq pin by using port input mode register g (PIMg) and port output mode register g (POMg).

**Remarks 1.**  $V_b[V]$ : Communication line voltage

**2.** q: UART number (q = 0 to 3), g: PIM and POM number (g = 0, 1, 8, 14)

**3.**  $f_{MCK}$ : Serial array unit operation clock frequency

(Operation clock to be set by the CKSmn bit of serial mode register mn (SMRmn). m: Unit number, n: Channel number (mn = 00 to 03, 10 to 13))

**4.**  $V_{IH}$  and  $V_{IL}$  below are observation points for the AC characteristics of the serial array unit when communicating at different potentials in UART mode.

$4.0\text{ V} \leq EV_{DD0} \leq 5.5\text{ V}$ ,  $2.7\text{ V} \leq V_b \leq 4.0\text{ V}$ :  $V_{IH} = 2.2\text{ V}$ ,  $V_{IL} = 0.8\text{ V}$

$2.7\text{ V} \leq EV_{DD0} < 4.0\text{ V}$ ,  $2.3\text{ V} \leq V_b \leq 2.7\text{ V}$ :  $V_{IH} = 2.0\text{ V}$ ,  $V_{IL} = 0.5\text{ V}$

<R>  $1.8\text{ V} \leq EV_{DD0} < 3.3\text{ V}$ ,  $1.6\text{ V} \leq V_b \leq 2.0\text{ V}$ :  $V_{IH} = 1.5\text{ V}$ ,  $V_{IL} = 0.32\text{ V}$

<R> **5.** UART2 cannot communicate at different potential when bit 1 (PIOR1) of peripheral I/O redirection register (PIOR) is 1.

**Caution** The pins mounted depend on the product. Refer to 2.1.1 20-pin products to 2.1.14 128-pin products, and 2.1.15 Pins for each product (pins other than port pins).

**(6) Communication at different potential (2.5 V, 3 V) (UART mode) (dedicated baud rate generator output) (2/2)**  
**(T<sub>A</sub> = -40 to +85°C, 1.8 V ≤ EV<sub>DD0</sub> = EV<sub>DD1</sub> ≤ V<sub>DD</sub> ≤ 5.5 V, V<sub>SS</sub> = EV<sub>SS0</sub> = EV<sub>SS1</sub> = 0 V)**

Parameter	Symbol	Conditions	MIN.	TYP.	MAX.	Unit
<R> Transfer rate	transmission	4.0 V ≤ EV <sub>DD0</sub> ≤ 5.5 V, 2.7 V ≤ V <sub>b</sub> ≤ 4.0 V			<b>Notes 1, 2</b>	bps
			Theoretical value of the maximum transfer rate C <sub>b</sub> = 50 pF, R <sub>b</sub> = 1.4 kΩ, V <sub>b</sub> = 2.7 V		2.8 <sup>Note 3</sup>	Mbps
		2.7 V ≤ EV <sub>DD0</sub> < 4.0 V, 2.3 V ≤ V <sub>b</sub> ≤ 2.7 V			<b>Notes 2, 4</b>	bps
			Theoretical value of the maximum transfer rate C <sub>b</sub> = 50 pF, R <sub>b</sub> = 2.7 kΩ, V <sub>b</sub> = 2.3 V		1.2 <sup>Note 5</sup>	Mbps
		1.8 V ≤ EV <sub>DD0</sub> < 3.3 V, 1.6 V ≤ V <sub>b</sub> ≤ 2.0 V			<b>Notes 2, 6, 7</b>	bps
			Theoretical value of the maximum transfer rate C <sub>b</sub> = 50 pF, R <sub>b</sub> = 5.5 kΩ, V <sub>b</sub> = 1.6 V		0.43 <sup>Note 8</sup>	Mbps

**Notes 1.** The smaller maximum transfer rate derived by using f<sub>MCK</sub>/6 or the following expression is the valid maximum transfer rate.

Expression for calculating the transfer rate when 4.0 V ≤ EV<sub>DD0</sub> ≤ 5.5 V and 2.7 V ≤ V<sub>b</sub> ≤ 4.0 V

$$\text{Maximum transfer rate} = \frac{1}{\{-C_b \times R_b \times \ln(1 - \frac{2.2}{V_b})\} \times 3} \text{ [bps]}$$

$$\text{Baud rate error (theoretical value)} = \frac{\frac{1}{\text{Transfer rate} \times 2} - \{-C_b \times R_b \times \ln(1 - \frac{2.2}{V_b})\}}{(\frac{1}{\text{Transfer rate}}) \times \text{Number of transferred bits}} \times 100 \text{ [%]}$$

\* This value is the theoretical value of the relative difference between the transmission and reception sides.

- <R> **2.** Transfer rate in the SNOOZE mode : MAX. 9600 bps, MIN. 4800 bps  
**3.** This value as an example is calculated when the conditions described in the “Conditions” column are met. Refer to Note 1 above to calculate the maximum transfer rate under conditions of the customer.  
**4.** The smaller maximum transfer rate derived by using f<sub>MCK</sub>/6 or the following expression is the valid maximum transfer rate.

Expression for calculating the transfer rate when 2.7 V ≤ EV<sub>DD0</sub> < 4.0 V and 2.3 V ≤ V<sub>b</sub> ≤ 2.7 V

$$\text{Maximum transfer rate} = \frac{1}{\{-C_b \times R_b \times \ln(1 - \frac{2.0}{V_b})\} \times 3} \text{ [bps]}$$

$$\text{Baud rate error (theoretical value)} = \frac{\frac{1}{\text{Transfer rate} \times 2} - \{-C_b \times R_b \times \ln(1 - \frac{2.0}{V_b})\}}{(\frac{1}{\text{Transfer rate}}) \times \text{Number of transferred bits}} \times 100 \text{ [%]}$$

\* This value is the theoretical value of the relative difference between the transmission and reception sides.

- 5.** This value as an example is calculated when the conditions described in the “Conditions” column are met. Refer to Note 4 above to calculate the maximum transfer rate under conditions of the customer.

**Caution** The pins mounted depend on the product. Refer to 2.1.1 20-pin products to 2.1.14 128-pin products, and 2.1.15 Pins for each product (pins other than port pins).

<R> **Notes** 6. Use it with  $EV_{DD0} \geq V_b$ .

7. The smaller maximum transfer rate derived by using  $f_{MCK}/6$  or the following expression is the valid maximum transfer rate.

<R> Expression for calculating the transfer rate when  $1.8\text{ V} \leq EV_{DD0} < 3.3\text{ V}$  and  $1.6\text{ V} \leq V_b \leq 2.0\text{ V}$

$$\text{Maximum transfer rate} = \frac{1}{\{-C_b \times R_b \times \ln(1 - \frac{1.5}{V_b})\} \times 3} \text{ [bps]}$$

$$\text{Baud rate error (theoretical value)} = \frac{\frac{1}{\text{Transfer rate} \times 2} - \{-C_b \times R_b \times \ln(1 - \frac{1.5}{V_b})\}}{(\frac{1}{\text{Transfer rate}}) \times \text{Number of transferred bits}} \times 100 \text{ [%]}$$

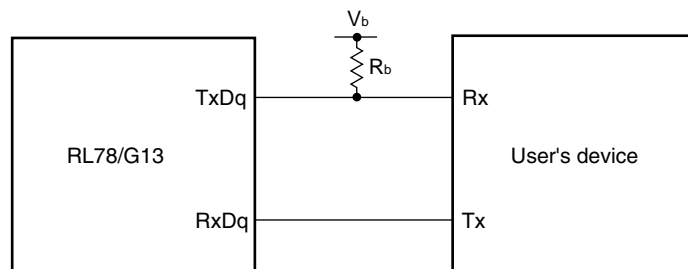
\* This value is the theoretical value of the relative difference between the transmission and reception sides.

8. This value as an example is calculated when the conditions described in the “Conditions” column are met. Refer to Note 7 above to calculate the maximum transfer rate under conditions of the customer.

**Caution** Select the TTL input buffer for the RxDq pin and the N-ch open drain output ( $V_{DD}$  tolerance) mode for the TxDq pin by using port input mode register g (PIMg) and port output mode register g (POMg).

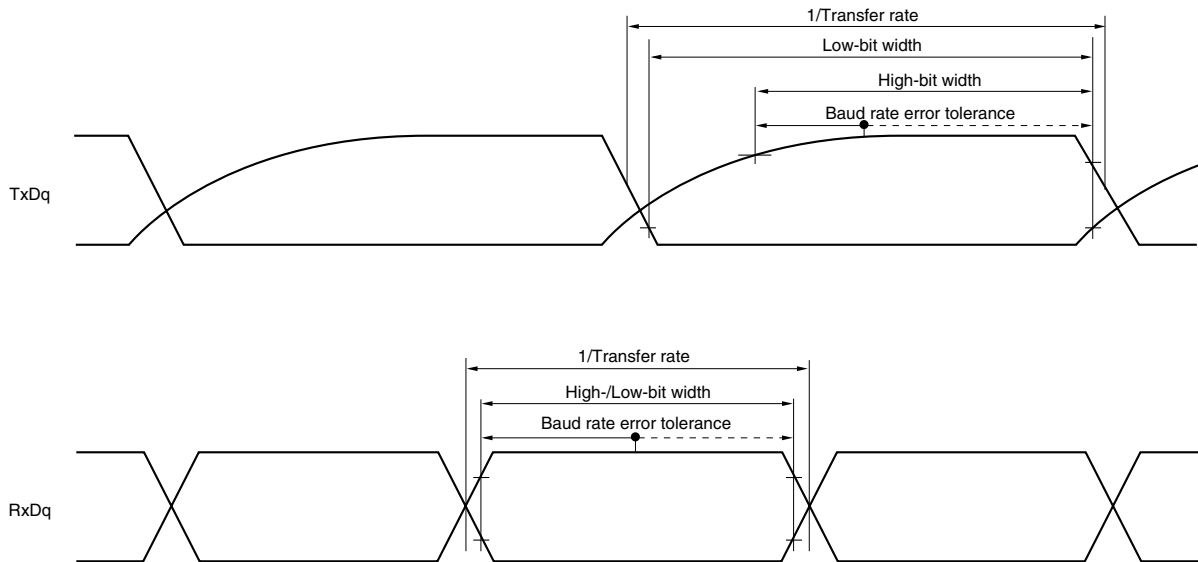
- Remarks**
1.  $R_b[\Omega]$ : Communication line (TxDq) pull-up resistance,  
 $C_b[F]$ : Communication line (TxDq) load capacitance,  $V_b[V]$ : Communication line voltage
  2. q: UART number (q = 0 to 3), g: PIM and POM number (g = 0, 1, 8, 14)
  3.  $f_{MCK}$ : Serial array unit operation clock frequency  
 (Operation clock to be set by the CKSmn bit of serial mode register mn (SMRmn).  
 m: Unit number, n: Channel number (mn = 00 to 03, 10 to 13))
  4.  $V_{IH}$  and  $V_{IL}$  below are observation points for the AC characteristics of the serial array unit when communicating at different potentials in UART mode.  
 $4.0\text{ V} \leq EV_{DD0} \leq 5.5\text{ V}, 2.7\text{ V} \leq V_b \leq 4.0\text{ V}: V_{IH} = 2.2\text{ V}, V_{IL} = 0.8\text{ V}$   
 $2.7\text{ V} \leq EV_{DD0} < 4.0\text{ V}, 2.3\text{ V} \leq V_b \leq 2.7\text{ V}: V_{IH} = 2.0\text{ V}, V_{IL} = 0.5\text{ V}$   
 $1.8\text{ V} \leq EV_{DD0} < 3.3\text{ V}, 1.6\text{ V} \leq V_b \leq 2.0\text{ V}: V_{IH} = 1.5\text{ V}, V_{IL} = 0.32\text{ V}$
  5. UART2 cannot communicate at different potential when bit 1 (PIOR1) of peripheral I/O redirection register (PIOR) is 1.

**UART mode connection diagram (during communication at different potential)**



**Caution** The pins mounted depend on the product. Refer to 2.1.1 20-pin products to 2.1.14 128-pin products, and 2.1.15 Pins for each product (pins other than port pins).

**UART mode bit width (during communication at different potential) (reference)**



**Caution** Select the TTL input buffer for the RxDq pin and the N-ch open drain output ( $V_{DD}$  tolerance) mode for the TxDq pin by using port input mode register g (PIMg) and port output mode register g (POMg).

- Remarks**
1. UART2 cannot communicate at different potential when bit 1 (PIOR1) of peripheral I/O redirection register (PIOR) is 1.
  2.  $R_b[\Omega]$ : Communication line (TxDq) pull-up resistance,  $V_b[V]$ : Communication line voltage
  3. q: UART number (q = 0 to 3), g: PIM and POM number (g = 0, 1, 8, 14)

**Caution** The pins mounted depend on the product. Refer to 2.1.1 20-pin products to 2.1.14 128-pin products, and 2.1.15 Pins for each product (pins other than port pins).

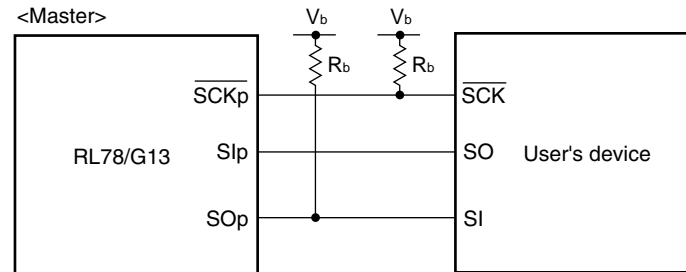
**(7) Communication at different potential (2.5 V, 3 V) ( $f_{MCK}/2$ ) (CSI mode) (master mode,  $\overline{SCKp}$ ... internal clock output)  
( $T_A = -40$  to  $+85^\circ\text{C}$ ,  $2.7\text{ V} \leq EV_{DD0} = EV_{DD1} \leq V_{DD} \leq 5.5\text{ V}$ ,  $V_{SS} = EV_{SS0} = EV_{SS1} = 0\text{ V}$ )**

Parameter	Symbol	Conditions	MIN.	TYP.	MAX.	Unit
$\overline{SCKp}$ cycle time	$t_{KCY1}$	$4.0\text{ V} \leq EV_{DD0} \leq 5.5\text{ V}$ , $2.7\text{ V} \leq V_b \leq 4.0\text{ V}$ , $C_b = 20\text{ pF}$ , $R_b = 1.4\text{ k}\Omega$	200 <sup>Note 1</sup>			ns
		$2.7\text{ V} \leq EV_{DD0} < 4.0\text{ V}$ , $2.3\text{ V} \leq V_b \leq 2.7\text{ V}$ , $C_b = 20\text{ pF}$ , $R_b = 2.7\text{ k}\Omega$	300 <sup>Note 1</sup>			ns
$\overline{SCKp}$ high-level width	$t_{KH1}$	$4.0\text{ V} \leq EV_{DD0} \leq 5.5\text{ V}$ , $2.7\text{ V} \leq V_b \leq 4.0\text{ V}$ , $C_b = 20\text{ pF}$ , $R_b = 1.4\text{ k}\Omega$	$t_{KCY1}/2 - 50$			ns
		$2.7\text{ V} \leq EV_{DD0} < 4.0\text{ V}$ , $2.3\text{ V} \leq V_b \leq 2.7\text{ V}$ , $C_b = 20\text{ pF}$ , $R_b = 2.7\text{ k}\Omega$	$t_{KCY1}/2 - 120$			ns
$\overline{SCKp}$ low-level width	$t_{KL1}$	$4.0\text{ V} \leq EV_{DD0} \leq 5.5\text{ V}$ , $2.7\text{ V} \leq V_b \leq 4.0\text{ V}$ , $C_b = 20\text{ pF}$ , $R_b = 1.4\text{ k}\Omega$	$t_{KCY1}/2 - 7$			ns
		$2.7\text{ V} \leq EV_{DD0} < 4.0\text{ V}$ , $2.3\text{ V} \leq V_b \leq 2.7\text{ V}$ , $C_b = 20\text{ pF}$ , $R_b = 2.7\text{ k}\Omega$	$t_{KCY1}/2 - 10$			ns
Slp setup time (to $\overline{SCKp}\uparrow$ ) <sup>Note 2</sup>	$t_{SIK1}$	$4.0\text{ V} \leq EV_{DD0} \leq 5.5\text{ V}$ , $2.7\text{ V} \leq V_b \leq 4.0\text{ V}$ , $C_b = 20\text{ pF}$ , $R_b = 1.4\text{ k}\Omega$	58			ns
		$2.7\text{ V} \leq EV_{DD0} < 4.0\text{ V}$ , $2.3\text{ V} \leq V_b \leq 2.7\text{ V}$ , $C_b = 20\text{ pF}$ , $R_b = 2.7\text{ k}\Omega$	121			ns
Slp hold time (from $\overline{SCKp}\uparrow$ ) <sup>Note 2</sup>	$t_{KSI1}$	$4.0\text{ V} \leq EV_{DD0} \leq 5.5\text{ V}$ , $2.7\text{ V} \leq V_b \leq 4.0\text{ V}$ , $C_b = 20\text{ pF}$ , $R_b = 1.4\text{ k}\Omega$	10			ns
		$2.7\text{ V} \leq EV_{DD0} < 4.0\text{ V}$ , $2.3\text{ V} \leq V_b \leq 2.7\text{ V}$ , $C_b = 20\text{ pF}$ , $R_b = 2.7\text{ k}\Omega$	10			ns
Delay time from $\overline{SCKp}\downarrow$ to SOP output <sup>Note 2</sup>	$t_{KSO1}$	$4.0\text{ V} \leq EV_{DD0} \leq 5.5\text{ V}$ , $2.7\text{ V} \leq V_b \leq 4.0\text{ V}$ , $C_b = 20\text{ pF}$ , $R_b = 1.4\text{ k}\Omega$			60	ns
		$2.7\text{ V} \leq EV_{DD0} < 4.0\text{ V}$ , $2.3\text{ V} \leq V_b \leq 2.7\text{ V}$ , $C_b = 20\text{ pF}$ , $R_b = 2.7\text{ k}\Omega$			130	ns
Slp setup time (to $\overline{SCKp}\downarrow$ ) <sup>Note 3</sup>	$t_{SIK1}$	$4.0\text{ V} \leq EV_{DD0} \leq 5.5\text{ V}$ , $2.7\text{ V} \leq V_b \leq 4.0\text{ V}$ , $C_b = 20\text{ pF}$ , $R_b = 1.4\text{ k}\Omega$	23			ns
		$2.7\text{ V} \leq EV_{DD0} < 4.0\text{ V}$ , $2.3\text{ V} \leq V_b \leq 2.7\text{ V}$ , $C_b = 20\text{ pF}$ , $R_b = 2.7\text{ k}\Omega$	33			ns
Slp hold time (from $\overline{SCKp}\downarrow$ ) <sup>Note 3</sup>	$t_{KSI1}$	$4.0\text{ V} \leq EV_{DD0} \leq 5.5\text{ V}$ , $2.7\text{ V} \leq V_b \leq 4.0\text{ V}$ , $C_b = 20\text{ pF}$ , $R_b = 1.4\text{ k}\Omega$	10			ns
		$2.7\text{ V} \leq EV_{DD0} < 4.0\text{ V}$ , $2.3\text{ V} \leq V_b \leq 2.7\text{ V}$ , $C_b = 20\text{ pF}$ , $R_b = 2.7\text{ k}\Omega$	10			ns
Delay time from $\overline{SCKp}\uparrow$ to SOP output <sup>Note 3</sup>	$t_{KSO1}$	$4.0\text{ V} \leq EV_{DD0} \leq 5.5\text{ V}$ , $2.7\text{ V} \leq V_b \leq 4.0\text{ V}$ , $C_b = 20\text{ pF}$ , $R_b = 1.4\text{ k}\Omega$			10	ns
		$2.7\text{ V} \leq EV_{DD0} < 4.0\text{ V}$ , $2.3\text{ V} \leq V_b \leq 2.7\text{ V}$ , $C_b = 20\text{ pF}$ , $R_b = 2.7\text{ k}\Omega$			10	ns

(Note, Caution and Remark are listed on the next page.)

**Caution** The pins mounted depend on the product. Refer to 2.1.1 20-pin products to 2.1.14 128-pin products, and 2.1.15 Pins for each product (pins other than port pins).

**CSI mode connection diagram (during communication at different potential)**



- Notes**
1. The value must also be  $2/f_{CLK}$  or more.
  2. When  $DAPmn = 0$  and  $CKPmn = 0$ , or  $DAPmn = 1$  and  $CKPmn = 1$ .
  3. When  $DAPmn = 0$  and  $CKPmn = 1$ , or  $DAPmn = 1$  and  $CKPmn = 0$ .

**Caution** Select the TTL input buffer for the Slp pin and the N-ch open drain output ( $V_{DD}$  tolerance) mode for the SOp pin and  $\overline{SCKp}$  pin by using port input mode register g (PIMg) and port output mode register g (POMg).

**Remarks** 1.  $R_b[\Omega]$ : Communication line ( $\overline{SCKp}$ , SOp) pull-up resistance,  $C_b[F]$ : Communication line ( $\overline{SCKp}$ , SOp) load capacitance,  $V_b[V]$ : Communication line voltage

2. p: CSI number ( $p = 00$ ), m: Unit number ( $m = 0$ ), n: Channel number ( $n = 0$ ), g: PIM and POM number ( $g = 1$ )

<R> 3.  $V_{IH}$  and  $V_{IL}$  below are observation points for the AC characteristics of the serial array unit when communicating at different potentials in CSI mode.

$$4.0 \text{ V} \leq EV_{DD0} \leq 5.5 \text{ V}, 2.7 \text{ V} \leq V_b \leq 4.0 \text{ V}: V_{IH} = 2.2 \text{ V}, V_{IL} = 0.8 \text{ V}$$

$$2.7 \text{ V} \leq EV_{DD0} < 4.0 \text{ V}, 2.3 \text{ V} \leq V_b \leq 2.7 \text{ V}: V_{IH} = 2.0 \text{ V}, V_{IL} = 0.5 \text{ V}$$

4.  $f_{MCK}$ : Serial array unit operation clock frequency  
(Operation clock to be set by the CKSmn bit of serial mode register mn (SMRmn). m: Unit number, n: Channel number ( $mn = 00$ ))

<R> 5. This specification is valid only when CSI00's peripheral I/O redirect function is not used.

**Caution** The pins mounted depend on the product. Refer to 2.1.1 20-pin products to 2.1.14 128-pin products, and 2.1.15 Pins for each product (pins other than port pins).

**(8) Communication at different potential (2.5 V, 3 V) ( $f_{mck}/4$ ) (CSI mode) (master mode,  $\overline{SCKp}$ ... internal clock output) (1/2)**  
**( $T_A = -40$  to  $+85^\circ\text{C}$ ,  $1.8\text{ V} \leq EV_{DD0} = EV_{DD1} \leq V_{DD} \leq 5.5\text{ V}$ ,  $V_{SS} = EV_{SS0} = EV_{SS1} = 0\text{ V}$ )**

Parameter	Symbol	Conditions	MIN.	TYP.	MAX.	Unit
<R> $\overline{SCKp}$ cycle time	$t_{kCY1}$	$4.0\text{ V} \leq EV_{DD0} \leq 5.5\text{ V}$ , $2.7\text{ V} \leq V_b \leq 4.0\text{ V}$ , $C_b = 30\text{ pF}$ , $R_b = 1.4\text{ k}\Omega$	300 <sup>Note</sup>			ns
		$2.7\text{ V} \leq EV_{DD0} < 4.0\text{ V}$ , $2.3\text{ V} \leq V_b \leq 2.7\text{ V}$ , $C_b = 30\text{ pF}$ , $R_b = 2.7\text{ k}\Omega$	500 <sup>Note</sup>			ns
		$1.8\text{ V} \leq EV_{DD0} < 3.3\text{ V}$ , $1.6\text{ V} \leq V_b \leq 2.0\text{ V}$ , $C_b = 30\text{ pF}$ , $R_b = 5.5\text{ k}\Omega$	1150 <sup>Note</sup>			ns
<R> $\overline{SCKp}$ high-level width	$t_{kH1}$	$4.0\text{ V} \leq EV_{DD0} \leq 5.5\text{ V}$ , $2.7\text{ V} \leq V_b \leq 4.0\text{ V}$ , $C_b = 30\text{ pF}$ , $R_b = 1.4\text{ k}\Omega$	$t_{kCY1}/2 - 75$			ns
		$2.7\text{ V} \leq EV_{DD0} < 4.0\text{ V}$ , $2.3\text{ V} \leq V_b \leq 2.7\text{ V}$ , $C_b = 30\text{ pF}$ , $R_b = 2.7\text{ k}\Omega$	$t_{kCY1}/2 - 170$			ns
		$1.8\text{ V} \leq EV_{DD0} < 3.3\text{ V}$ , $1.6\text{ V} \leq V_b \leq 2.0\text{ V}$ , $C_b = 30\text{ pF}$ , $R_b = 5.5\text{ k}\Omega$	$t_{kCY1}/2 - 458$			ns
<R> $\overline{SCKp}$ low-level width	$t_{kL1}$	$4.0\text{ V} \leq EV_{DD0} \leq 5.5\text{ V}$ , $2.7\text{ V} \leq V_b \leq 4.0\text{ V}$ , $C_b = 30\text{ pF}$ , $R_b = 1.4\text{ k}\Omega$	$t_{kCY1}/2 - 12$			ns
		$2.7\text{ V} \leq EV_{DD0} < 4.0\text{ V}$ , $2.3\text{ V} \leq V_b \leq 2.7\text{ V}$ , $C_b = 30\text{ pF}$ , $R_b = 2.7\text{ k}\Omega$	$t_{kCY1}/2 - 18$			ns
		$1.8\text{ V} \leq EV_{DD0} < 3.3\text{ V}$ , $1.6\text{ V} \leq V_b \leq 2.0\text{ V}$ , $C_b = 30\text{ pF}$ , $R_b = 5.5\text{ k}\Omega$	$t_{kCY1}/2 - 50$			ns

**Note** The value must also be  $4/f_{CLK}$  or more.

**Cautions** 1. Select the TTL input buffer for the  $S_{Ip}$  pin and the N-ch open drain output ( $V_{DD}$  tolerance) mode for the  $S_{Op}$  pin and  $\overline{SCKp}$  pin by using port input mode register g (PIMg) and port output mode register g (POMg).

2. Use it with  $EV_{DD0} \geq V_b$ .

**Remarks** 1.  $R_b[\Omega]$ : Communication line ( $\overline{SCKp}$ ,  $S_{Op}$ ) pull-up resistance,  $C_b[\text{F}]$ : Communication line ( $\overline{SCKp}$ ,  $S_{Op}$ ) load capacitance,  $V_b[\text{V}]$ : Communication line voltage

2. p: CSI number (p = 00, 01, 10, 20, 30, 31), m: Unit number, n: Channel number (mn = 00, 01, 02, 10, 12, 13), g: PIM and POM number (g = 0, 1, 4, 5, 8, 14)

3.  $V_{IH}$  and  $V_{IL}$  below are observation points for the AC characteristics of the serial array unit when communicating at different potentials in CSI mode.

$4.0\text{ V} \leq EV_{DD0} \leq 5.5\text{ V}$ ,  $2.7\text{ V} \leq V_b \leq 4.0\text{ V}$ :  $V_{IH} = 2.2\text{ V}$ ,  $V_{IL} = 0.8\text{ V}$

$2.7\text{ V} \leq EV_{DD0} < 4.0\text{ V}$ ,  $2.3\text{ V} \leq V_b \leq 2.7\text{ V}$ :  $V_{IH} = 2.0\text{ V}$ ,  $V_{IL} = 0.5\text{ V}$

<R>  $1.8\text{ V} \leq EV_{DD0} < 3.3\text{ V}$ ,  $1.6\text{ V} \leq V_b \leq 2.0\text{ V}$ :  $V_{IH} = 1.5\text{ V}$ ,  $V_{IL} = 0.32\text{ V}$

4. CSI01 of 48-, 52-, 64-pin products, and CSI11 and CSI21 cannot communicate at different potential. Use other CSI for communication at different potential.



**Caution** The pins mounted depend on the product. Refer to 2.1.1 20-pin products to 2.1.14 128-pin products, and 2.1.15 Pins for each product (pins other than port pins).

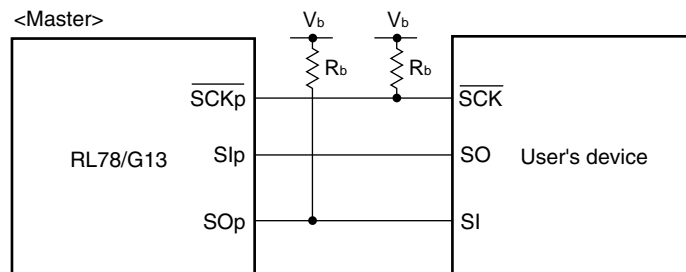
**(8) Communication at different potential (2.5 V, 3 V) ( $f_{mck}/4$ ) (CSI mode) (master mode,  $\overline{SCKp}$ ... internal clock output) (2/2)**  
**( $T_A = -40$  to  $+85^\circ\text{C}$ ,  $1.8\text{ V} \leq EV_{DD0} = EV_{DD1} \leq V_{DD} \leq 5.5\text{ V}$ ,  $V_{SS} = EV_{SS0} = EV_{SS1} = 0\text{ V}$ )**

Parameter	Symbol	Conditions	MIN.	TYP.	MAX.	Unit
<R> Slp setup time (to $\overline{SCKp}\uparrow$ ) <sup>Note 1</sup>	$t_{SIK1}$	$4.0\text{ V} \leq EV_{DD0} \leq 5.5\text{ V}$ , $2.7\text{ V} \leq V_b \leq 4.0\text{ V}$ , $C_b = 30\text{ pF}$ , $R_b = 1.4\text{ k}\Omega$	81			ns
		$2.7\text{ V} \leq EV_{DD0} < 4.0\text{ V}$ , $2.3\text{ V} \leq V_b \leq 2.7\text{ V}$ , $C_b = 30\text{ pF}$ , $R_b = 2.7\text{ k}\Omega$	177			ns
		$1.8\text{ V} \leq EV_{DD0} < 3.3\text{ V}$ , $1.6\text{ V} \leq V_b \leq 2.0\text{ V}$ , $C_b = 30\text{ pF}$ , $R_b = 5.5\text{ k}\Omega$	479			ns
<R> Slp hold time (from $\overline{SCKp}\uparrow$ ) <sup>Note 1</sup>	$t_{SIK1}$	$4.0\text{ V} \leq EV_{DD0} \leq 5.5\text{ V}$ , $2.7\text{ V} \leq V_b \leq 4.0\text{ V}$ , $C_b = 30\text{ pF}$ , $R_b = 1.4\text{ k}\Omega$	19			ns
		$2.7\text{ V} \leq EV_{DD0} < 4.0\text{ V}$ , $2.3\text{ V} \leq V_b \leq 2.7\text{ V}$ , $C_b = 30\text{ pF}$ , $R_b = 2.7\text{ k}\Omega$	19			ns
		$1.8\text{ V} \leq EV_{DD0} < 3.3\text{ V}$ , $1.6\text{ V} \leq V_b \leq 2.0\text{ V}$ , $C_b = 30\text{ pF}$ , $R_b = 5.5\text{ k}\Omega$	19			ns
<R> Delay time from $\overline{SCKp}\downarrow$ to SOP output <sup>Note 1</sup>	$t_{KSO1}$	$4.0\text{ V} \leq EV_{DD0} \leq 5.5\text{ V}$ , $2.7\text{ V} \leq V_b \leq 4.0\text{ V}$ , $C_b = 30\text{ pF}$ , $R_b = 1.4\text{ k}\Omega$			100	ns
		$2.7\text{ V} \leq EV_{DD0} < 4.0\text{ V}$ , $2.3\text{ V} \leq V_b \leq 2.7\text{ V}$ , $C_b = 30\text{ pF}$ , $R_b = 2.7\text{ k}\Omega$			195	ns
		$1.8\text{ V} \leq EV_{DD0} < 3.3\text{ V}$ , $1.6\text{ V} \leq V_b \leq 2.0\text{ V}$ , $C_b = 30\text{ pF}$ , $R_b = 5.5\text{ k}\Omega$			483	ns
<R> Slp setup time (to $\overline{SCKp}\downarrow$ ) <sup>Note 2</sup>	$t_{SIK1}$	$4.0\text{ V} \leq EV_{DD0} \leq 5.5\text{ V}$ , $2.7\text{ V} \leq V_b \leq 4.0\text{ V}$ , $C_b = 30\text{ pF}$ , $R_b = 1.4\text{ k}\Omega$	44			ns
		$2.7\text{ V} \leq EV_{DD0} < 4.0\text{ V}$ , $2.3\text{ V} \leq V_b \leq 2.7\text{ V}$ , $C_b = 30\text{ pF}$ , $R_b = 2.7\text{ k}\Omega$	44			ns
		$1.8\text{ V} \leq EV_{DD0} < 3.3\text{ V}$ , $1.6\text{ V} \leq V_b \leq 2.0\text{ V}$ , $C_b = 30\text{ pF}$ , $R_b = 5.5\text{ k}\Omega$	110			ns
<R> Slp hold time (from $\overline{SCKp}\downarrow$ ) <sup>Note 2</sup>	$t_{SIK1}$	$4.0\text{ V} \leq EV_{DD0} \leq 5.5\text{ V}$ , $2.7\text{ V} \leq V_b \leq 4.0\text{ V}$ , $C_b = 30\text{ pF}$ , $R_b = 1.4\text{ k}\Omega$	19			ns
		$2.7\text{ V} \leq EV_{DD0} < 4.0\text{ V}$ , $2.3\text{ V} \leq V_b \leq 2.7\text{ V}$ , $C_b = 30\text{ pF}$ , $R_b = 2.7\text{ k}\Omega$	19			ns
		$1.8\text{ V} \leq EV_{DD0} < 3.3\text{ V}$ , $1.6\text{ V} \leq V_b \leq 2.0\text{ V}$ , $C_b = 30\text{ pF}$ , $R_b = 5.5\text{ k}\Omega$	19			ns
<R> Delay time from $\overline{SCKp}\uparrow$ to SOP output <sup>Note 2</sup>	$t_{KSO1}$	$4.0\text{ V} \leq EV_{DD0} \leq 5.5\text{ V}$ , $2.7\text{ V} \leq V_b \leq 4.0\text{ V}$ , $C_b = 30\text{ pF}$ , $R_b = 1.4\text{ k}\Omega$			25	ns
		$2.7\text{ V} \leq EV_{DD0} < 4.0\text{ V}$ , $2.3\text{ V} \leq V_b \leq 2.7\text{ V}$ , $C_b = 30\text{ pF}$ , $R_b = 2.7\text{ k}\Omega$			25	ns
		$1.8\text{ V} \leq EV_{DD0} < 3.3\text{ V}$ , $1.6\text{ V} \leq V_b \leq 2.0\text{ V}$ , $C_b = 30\text{ pF}$ , $R_b = 5.5\text{ k}\Omega$			25	ns

(Notes, Cautions and Remarks are listed on the next page.)

**Caution** The pins mounted depend on the product. Refer to 2.1.1 20-pin products to 2.1.14 128-pin products, and 2.1.15 Pins for each product (pins other than port pins).

**CSI mode connection diagram (during communication at different potential)**



- Notes**
1. When DAPmn = 0 and CKPmn = 0, or DAPmn = 1 and CKPmn = 1.
  2. When DAPmn = 0 and CKPmn = 1, or DAPmn = 1 and CKPmn = 0.

**Cautions**

1. Select the TTL input buffer for the Slp pin and the N-ch open drain output (V<sub>DD</sub> tolerance) mode for the SOp pin and SCKp pin by using port input mode register g (PIMg) and port output mode register g (POMg).

<R> 2. Use it with  $EV_{DD0} \geq V_b$ .

- Remarks**
1.  $R_b[\Omega]$ : Communication line ( $\overline{SCKp}$ , SOp) pull-up resistance,  $C_b[F]$ : Communication line ( $\overline{SCKp}$ , SOp) load capacitance,  $V_b[V]$ : Communication line voltage
  2. p: CSI number (p = 00, 01, 10, 20, 30, 31), m: Unit number, n: Channel number (mn = 00, 01, 02, 10, 12, 13), g: PIM and POM number (g = 0, 1, 4, 5, 8, 14)
  3.  $V_{IH}$  and  $V_{IL}$  below are observation points for the AC characteristics of the serial array unit when communicating at different potentials in CSI mode.

$$4.0 \text{ V} \leq EV_{DD0} \leq 5.5 \text{ V}, 2.7 \text{ V} \leq V_b \leq 4.0 \text{ V}: V_{IH} = 2.2 \text{ V}, V_{IL} = 0.8 \text{ V}$$

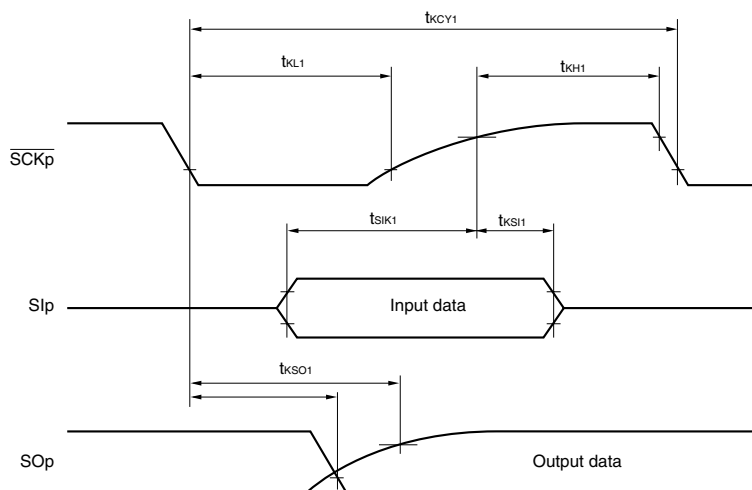
$$2.7 \text{ V} \leq EV_{DD0} < 4.0 \text{ V}, 2.3 \text{ V} \leq V_b \leq 2.7 \text{ V}: V_{IH} = 2.0 \text{ V}, V_{IL} = 0.5 \text{ V}$$

$$1.8 \text{ V} \leq EV_{DD0} < 3.3 \text{ V}, 1.6 \text{ V} \leq V_b \leq 2.0 \text{ V}: V_{IH} = 1.5 \text{ V}, V_{IL} = 0.32 \text{ V}$$

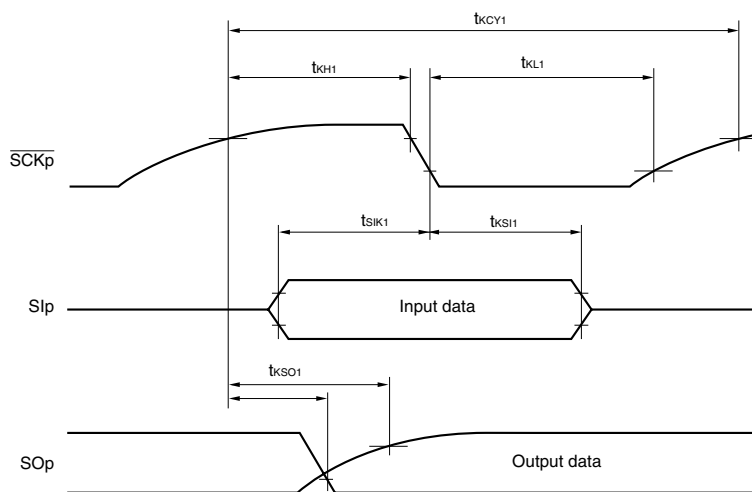
- <R> 4. CSI01 of 48-, 52-, 64-pin products, and CSI11 and CSI21 cannot communicate at different potential. Use other CSI for communication at different potential.

**Caution** The pins mounted depend on the product. Refer to 2.1.1 20-pin products to 2.1.14 128-pin products, and 2.1.15 Pins for each product (pins other than port pins).

**CSI mode serial transfer timing (master mode) (during communication at different potential)  
(When DAPmn = 0 and CKPmn = 0, or DAPmn = 1 and CKPmn = 1.)**



**CSI mode serial transfer timing (master mode) (during communication at different potential)  
(When DAPmn = 0 and CKPmn = 1, or DAPmn = 1 and CKPmn = 0.)**



**Caution** Select the TTL input buffer for the Slp pin and the N-ch open drain output ( $V_{DD}$  tolerance) mode for the SOp pin and SCKp pin by using port input mode register g (PIMg) and port output mode register g (POMg).

- Remarks**
1. p: CSI number (p = 00, 01, 10, 20, 30, 31), m: Unit number (m = 00, 01, 02, 10, 12, 13), n: Channel number (n = 0, 2), g: PIM and POM number (g = 0, 1, 4, 5, 8, 14)
  2. CSI01 of 48-, 52-, 64-pin products, and CSI11 and CSI21 cannot communicate at different potential. Use other CSI for communication at different potential.

**Caution** The pins mounted depend on the product. Refer to 2.1.1 20-pin products to 2.1.14 128-pin products, and 2.1.15 Pins for each product (pins other than port pins).

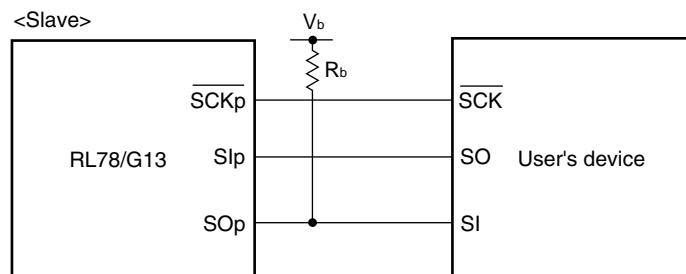
**(9) Communication at different potential (2.5 V, 3 V) (CSI mode) (slave mode,  $\overline{\text{SCKp}}$ ... external clock input)**  
**( $T_A = -40$  to  $+85^\circ\text{C}$ ,  $1.8\text{ V} \leq \text{EV}_{\text{DD0}} = \text{EV}_{\text{DD1}} \leq \text{V}_{\text{DD}} \leq 5.5\text{ V}$ ,  $\text{V}_{\text{SS}} = \text{EV}_{\text{SS0}} = \text{EV}_{\text{SS1}} = 0\text{ V}$ )**

Parameter	Symbol	Conditions	MIN.	TYP.	MAX.	Unit
<R> $\overline{\text{SCKp}}$ cycle time <sup>Note 1</sup>	$t_{\text{KCY2}}$	$4.0\text{ V} \leq \text{EV}_{\text{DD0}} \leq 5.5\text{ V}$ , $2.7\text{ V} \leq \text{V}_b \leq 4.0\text{ V}$	$24\text{ MHz} < f_{\text{MCK}}$	$14/f_{\text{MCK}}$		ns
			$20\text{ MHz} < f_{\text{MCK}} \leq 24\text{ MHz}$	$12/f_{\text{MCK}}$		ns
			$8\text{ MHz} < f_{\text{MCK}} \leq 20\text{ MHz}$	$10/f_{\text{MCK}}$		ns
			$4\text{ MHz} < f_{\text{MCK}} \leq 8\text{ MHz}$	$8/f_{\text{MCK}}$		ns
			$f_{\text{MCK}} \leq 4\text{ MHz}$	$6/f_{\text{MCK}}$		ns
		$2.7\text{ V} \leq \text{EV}_{\text{DD0}} < 4.0\text{ V}$ , $2.3\text{ V} \leq \text{V}_b \leq 2.7\text{ V}$	$24\text{ MHz} < f_{\text{MCK}}$	$20/f_{\text{MCK}}$		ns
			$20\text{ MHz} < f_{\text{MCK}} \leq 24\text{ MHz}$	$16/f_{\text{MCK}}$		ns
			$16\text{ MHz} < f_{\text{MCK}} \leq 20\text{ MHz}$	$14/f_{\text{MCK}}$		ns
			$8\text{ MHz} < f_{\text{MCK}} \leq 16\text{ MHz}$	$12/f_{\text{MCK}}$		ns
			$4\text{ MHz} < f_{\text{MCK}} \leq 8\text{ MHz}$	$8/f_{\text{MCK}}$		ns
		$1.8\text{ V} \leq \text{EV}_{\text{DD0}} < 3.3\text{ V}$ , $1.6\text{ V} \leq \text{V}_b \leq 2.0\text{ V}$ <sup>Note 2</sup>	$24\text{ MHz} < f_{\text{MCK}}$	$48/f_{\text{MCK}}$		ns
			$20\text{ MHz} < f_{\text{MCK}} \leq 24\text{ MHz}$	$36/f_{\text{MCK}}$		ns
			$16\text{ MHz} < f_{\text{MCK}} \leq 20\text{ MHz}$	$32/f_{\text{MCK}}$		ns
			$8\text{ MHz} < f_{\text{MCK}} \leq 16\text{ MHz}$	$26/f_{\text{MCK}}$		ns
			$4\text{ MHz} < f_{\text{MCK}} \leq 8\text{ MHz}$	$16/f_{\text{MCK}}$		ns
SCKp high-/low-level width	$t_{\text{KH2}}$ , $t_{\text{KL2}}$	$4.0\text{ V} \leq \text{EV}_{\text{DD0}} \leq 5.5\text{ V}$ , $2.7\text{ V} \leq \text{V}_b \leq 4.0\text{ V}$	$t_{\text{KCY2}}/2 - 12$		ns	
		$2.7\text{ V} \leq \text{EV}_{\text{DD0}} < 4.0\text{ V}$ , $2.3\text{ V} \leq \text{V}_b \leq 2.7\text{ V}$	$t_{\text{KCY2}}/2 - 18$		ns	
		$1.8\text{ V} \leq \text{EV}_{\text{DD0}} < 3.3\text{ V}$ , $1.6\text{ V} \leq \text{V}_b \leq 2.0\text{ V}$ <sup>Note 2</sup>	$t_{\text{KCY2}}/2 - 50$		ns	
<R> Slp setup time (to $\overline{\text{SCKp}}\uparrow$ ) <sup>Note 3</sup>	$t_{\text{SIK2}}$	$2.7\text{ V} \leq \text{EV}_{\text{DD0}} \leq 5.5\text{ V}$	$1/f_{\text{MCK}} + 20$		ns	
		$1.8\text{ V} \leq \text{EV}_{\text{DD0}} < 3.3\text{ V}$	$1/f_{\text{MCK}} + 30$		ns	
Slp hold time (from $\overline{\text{SCKp}}\uparrow$ ) <sup>Note 4</sup>	$t_{\text{SLI2}}$		$1/f_{\text{MCK}} + 31$		ns	
<R> Delay time from $\overline{\text{SCKp}}\downarrow$ to SOP output <sup>Note 5</sup>	$t_{\text{KSO2}}$	$4.0\text{ V} \leq \text{EV}_{\text{DD0}} \leq 5.5\text{ V}$ , $2.7\text{ V} \leq \text{V}_b \leq 4.0\text{ V}$ , $C_b = 30\text{ pF}$ , $R_b = 1.4\text{ k}\Omega$	$1/f_{\text{MCK}} + 250$		$2/f_{\text{MCK}} + 120$	ns
		$2.7\text{ V} \leq \text{EV}_{\text{DD0}} < 4.0\text{ V}$ , $2.3\text{ V} \leq \text{V}_b \leq 2.7\text{ V}$ , $C_b = 30\text{ pF}$ , $R_b = 2.7\text{ k}\Omega$			$2/f_{\text{MCK}} + 214$	ns
		$1.8\text{ V} \leq \text{EV}_{\text{DD0}} < 3.3\text{ V}$ , $1.6\text{ V} \leq \text{V}_b \leq 2.0\text{ V}$ <sup>Note 2</sup> , $C_b = 30\text{ pF}$ , $R_b = 5.5\text{ k}\Omega$			$2/f_{\text{MCK}} + 573$	ns

(Notes, Caution and Remarks are listed on the next page.)

**Caution** The pins mounted depend on the product. Refer to 2.1.1 20-pin products to 2.1.14 128-pin products, and 2.1.15 Pins for each product (pins other than port pins).

**CSI mode connection diagram (during communication at different potential)**



<R> **Notes** 1. Transfer rate in the SNOOZE mode : MAX. 1 Mbps

<R> 2. Use it with  $EV_{DD0} \geq V_b$ .

3. When  $DAP_{mn} = 0$  and  $CKP_{mn} = 0$ , or  $DAP_{mn} = 1$  and  $CKP_{mn} = 1$ . The Slp setup time becomes “to  $\overline{SCKp}\downarrow$ ” when  $DAP_{mn} = 0$  and  $CKP_{mn} = 1$ , or  $DAP_{mn} = 1$  and  $CKP_{mn} = 0$ .

4. When  $DAP_{mn} = 0$  and  $CKP_{mn} = 0$ , or  $DAP_{mn} = 1$  and  $CKP_{mn} = 1$ . The Slp hold time becomes “from  $\overline{SCKp}\downarrow$ ” when  $DAP_{mn} = 0$  and  $CKP_{mn} = 1$ , or  $DAP_{mn} = 1$  and  $CKP_{mn} = 0$ .

5. When  $DAP_{mn} = 0$  and  $CKP_{mn} = 0$ , or  $DAP_{mn} = 1$  and  $CKP_{mn} = 1$ . The delay time to SOp output becomes “from  $\overline{SCKp}\uparrow$ ” when  $DAP_{mn} = 0$  and  $CKP_{mn} = 1$ , or  $DAP_{mn} = 1$  and  $CKP_{mn} = 0$ .

**Caution** Select the TTL input buffer for the Slp pin and  $\overline{SCKp}$  pin and the N-ch open drain output ( $V_{DD}$  tolerance) mode for the SOp pin by using port input mode register g (PIMg) and port output mode register g (POMg).

**Remarks** 1.  $R_b[\Omega]$ : Communication line (SOp) pull-up resistance,  $C_b[F]$ : Communication line (SOp) load capacitance,  $V_b[V]$ : Communication line voltage

2. p: CSI number (p = 00, 01, 10, 20, 30, 31), m: Unit number (m = 0, 1), n: Channel number (n = 00, 01, 02, 10, 12, 13), g: PIM and POM number (g = 0, 1, 4, 5, 8, 14)

3.  $f_{MCK}$ : Serial array unit operation clock frequency  
(Operation clock to be set by the CKSmn bit of serial mode register mn (SMRmn).  
m: Unit number, n: Channel number (mn = 00, 01, 02, 10, 12, 13))

4.  $V_{IH}$  and  $V_{IL}$  below are observation points for the AC characteristics of the serial array unit when communicating at different potentials in CSI mode.

$$4.0 \text{ V} \leq EV_{DD0} \leq 5.5 \text{ V}, 2.7 \text{ V} \leq V_b \leq 4.0 \text{ V}: V_{IH} = 2.2 \text{ V}, V_{IL} = 0.8 \text{ V}$$

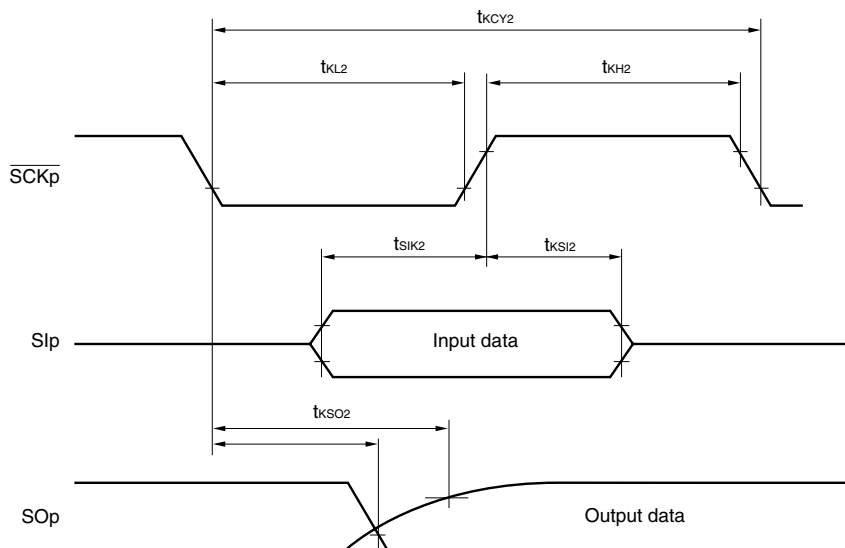
$$2.7 \text{ V} \leq EV_{DD0} < 4.0 \text{ V}, 2.3 \text{ V} \leq V_b \leq 2.7 \text{ V}: V_{IH} = 2.0 \text{ V}, V_{IL} = 0.5 \text{ V}$$

$$1.8 \text{ V} \leq EV_{DD0} < 3.3 \text{ V}, 1.6 \text{ V} \leq V_b \leq 2.0 \text{ V}: V_{IH} = 1.5 \text{ V}, V_{IL} = 0.32 \text{ V}$$

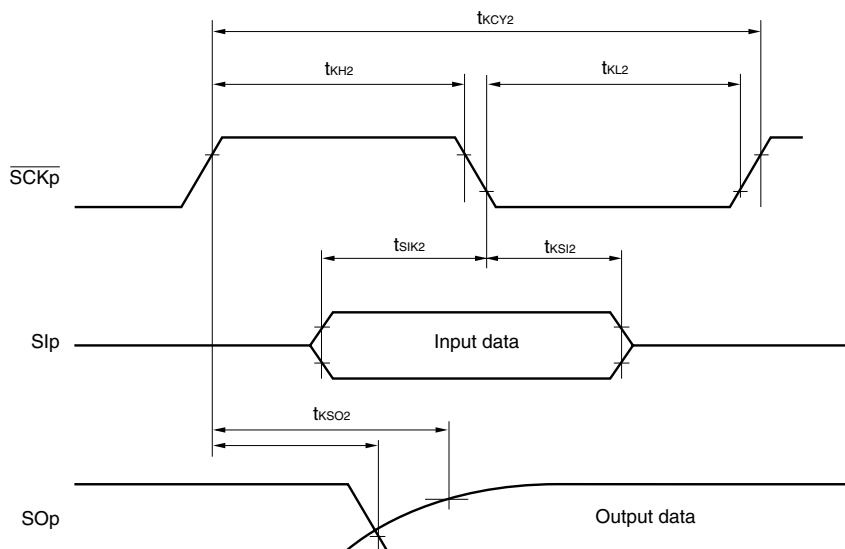
<R> 5. CSI01 of 48-, 52-, 64-pin products, and CSI11 and CSI21 cannot communicate at different potential. Use other CSI for communication at different potential.

**Caution** The pins mounted depend on the product. Refer to 2.1.1 20-pin products to 2.1.14 128-pin products, and 2.1.15 Pins for each product (pins other than port pins).

**CSI mode serial transfer timing (slave mode) (during communication at different potential)**  
 (When DAPmn = 0 and CKPmn = 0, or DAPmn = 1 and CKPmn = 1.)



**CSI mode serial transfer timing (slave mode) (during communication at different potential)**  
 (When DAPmn = 0 and CKPmn = 1, or DAPmn = 1 and CKPmn = 0.)



**Caution** Select the TTL input buffer for the Slp pin and SCKp pin and the N-ch open drain output ( $V_{DD}$  tolerance) mode for the SOp pin by using port input mode register g (PIMg) and port output mode register g (POMg).

- Remarks**
1. p: CSI number (p = 00, 01, 10, 20, 30, 31), m: Unit number, n: Channel number (mn = 00, 01, 02, 10, 12, 13), g: PIM and POM number (g = 0, 1, 4, 5, 8, 14)
  2. CSI01 of 48-, 52-, 64-pin products, and CSI11 and CSI21 cannot communicate at different potential. Use other CSI for communication at different potential.

**Caution** The pins mounted depend on the product. Refer to 2.1.1 20-pin products to 2.1.14 128-pin products, and 2.1.15 Pins for each product (pins other than port pins).

**(10) Communication at different potential (2.5 V, 3 V) (simplified I<sup>2</sup>C mode) (1/2)**

**(T<sub>A</sub> = -40 to +85°C, 1.8 V ≤ EV<sub>DD0</sub> = EV<sub>DD1</sub> ≤ V<sub>DD</sub> ≤ 5.5 V, V<sub>SS</sub> = EV<sub>SS0</sub> = EV<sub>SS1</sub> = 0 V)**

Parameter	Symbol	Conditions	MIN.	MAX.	Unit
<R> SCLr clock frequency	f <sub>SCL</sub>	4.0 V ≤ EV <sub>DD0</sub> ≤ 5.5 V, 2.7 V ≤ V <sub>b</sub> ≤ 4.0 V, C <sub>b</sub> = 50 pF, R <sub>b</sub> = 2.7 kΩ		1000	kHz
		2.7 V ≤ EV <sub>DD0</sub> < 4.0 V, 2.3 V ≤ V <sub>b</sub> < 2.7 V, C <sub>b</sub> = 50 pF, R <sub>b</sub> = 2.7 kΩ		1000	kHz
		4.0 V ≤ EV <sub>DD0</sub> ≤ 5.5 V, 2.7 V ≤ V <sub>b</sub> ≤ 4.0 V, C <sub>b</sub> = 100 pF, R <sub>b</sub> = 2.8 kΩ		400	kHz
		2.7 V ≤ EV <sub>DD0</sub> < 4.0 V, 2.3 V ≤ V <sub>b</sub> < 2.7 V, C <sub>b</sub> = 100 pF, R <sub>b</sub> = 2.7 kΩ		400	kHz
		1.8 V ≤ EV <sub>DD0</sub> < 3.3 V, 1.6 V ≤ V <sub>b</sub> ≤ 2.0 V <sup>Note 1</sup> , C <sub>b</sub> = 100 pF, R <sub>b</sub> = 5.5 kΩ		300	kHz
<R> Hold time when SCLr = "L"	t <sub>LOW</sub>	4.0 V ≤ EV <sub>DD0</sub> ≤ 5.5 V, 2.7 V ≤ V <sub>b</sub> ≤ 4.0 V, C <sub>b</sub> = 50 pF, R <sub>b</sub> = 2.7 kΩ	475		ns
		2.7 V ≤ EV <sub>DD0</sub> < 4.0 V, 2.3 V ≤ V <sub>b</sub> < 2.7 V, C <sub>b</sub> = 50 pF, R <sub>b</sub> = 2.7 kΩ	475		ns
		4.0 V ≤ EV <sub>DD0</sub> ≤ 5.5 V, 2.7 V ≤ V <sub>b</sub> ≤ 4.0 V, C <sub>b</sub> = 100 pF, R <sub>b</sub> = 2.8 kΩ	1150		ns
		2.7 V ≤ EV <sub>DD0</sub> < 4.0 V, 2.3 V ≤ V <sub>b</sub> < 2.7 V, C <sub>b</sub> = 100 pF, R <sub>b</sub> = 2.7 kΩ	1150		ns
		1.8 V ≤ EV <sub>DD0</sub> < 3.3 V, 1.6 V ≤ V <sub>b</sub> ≤ 2.0 V <sup>Note 1</sup> , C <sub>b</sub> = 100 pF, R <sub>b</sub> = 5.5 kΩ	1550		ns
<R> Hold time when SCLr = "H"	t <sub>HIGH</sub>	4.0 V ≤ EV <sub>DD0</sub> ≤ 5.5 V, 2.7 V ≤ V <sub>b</sub> ≤ 4.0 V, C <sub>b</sub> = 50 pF, R <sub>b</sub> = 2.7 kΩ	245		ns
		2.7 V ≤ EV <sub>DD0</sub> < 4.0 V, 2.3 V ≤ V <sub>b</sub> < 2.7 V, C <sub>b</sub> = 50 pF, R <sub>b</sub> = 2.7 kΩ	200		ns
		4.0 V ≤ EV <sub>DD0</sub> ≤ 5.5 V, 2.7 V ≤ V <sub>b</sub> ≤ 4.0 V, C <sub>b</sub> = 100 pF, R <sub>b</sub> = 2.8 kΩ	675		ns
		2.7 V ≤ EV <sub>DD0</sub> < 4.0 V, 2.3 V ≤ V <sub>b</sub> < 2.7 V, C <sub>b</sub> = 100 pF, R <sub>b</sub> = 2.7 kΩ	600		ns
		1.8 V ≤ EV <sub>DD0</sub> < 3.3 V, 1.6 V ≤ V <sub>b</sub> ≤ 2.0 V <sup>Note 1</sup> , C <sub>b</sub> = 100 pF, R <sub>b</sub> = 5.5 kΩ	610		ns

(Notes, Caution and Remarks are listed on the next page.)

**Caution** The pins mounted depend on the product. Refer to 2.1.1 20-pin products to 2.1.14 128-pin products, and 2.1.15 Pins for each product (pins other than port pins).

**(10) Communication at different potential (2.5 V, 3 V) (simplified I<sup>2</sup>C mode) (2/2)**

**(T<sub>A</sub> = -40 to +85°C, 1.8 V ≤ EV<sub>DD0</sub> = EV<sub>DD1</sub> ≤ V<sub>DD</sub> ≤ 5.5 V, V<sub>SS</sub> = EV<sub>SS0</sub> = EV<sub>SS1</sub> = 0 V)**

Parameter	Symbol	Conditions	MIN.	MAX.	Unit
<R> Data setup time (reception)	t <sub>SU:DAT</sub>	4.0 V ≤ EV <sub>DD0</sub> ≤ 5.5 V, 2.7 V ≤ V <sub>b</sub> ≤ 4.0 V, C <sub>b</sub> = 50 pF, R <sub>b</sub> = 2.7 kΩ	1/f <sub>MCK</sub> + 135 <small>Note 2</small>		ns
		2.7 V ≤ EV <sub>DD0</sub> < 4.0 V, 2.3 V ≤ V <sub>b</sub> < 2.7 V, C <sub>b</sub> = 50 pF, R <sub>b</sub> = 2.7 kΩ	1/f <sub>MCK</sub> + 135 <small>Note 2</small>		ns
		4.0 V ≤ EV <sub>DD0</sub> ≤ 5.5 V, 2.7 V ≤ V <sub>b</sub> ≤ 4.0 V, C <sub>b</sub> = 100 pF, R <sub>b</sub> = 2.8 kΩ	1/f <sub>MCK</sub> + 190 <small>Note 2</small>		ns
		2.7 V ≤ EV <sub>DD0</sub> < 4.0 V, 2.3 V ≤ V <sub>b</sub> < 2.7 V, C <sub>b</sub> = 100 pF, R <sub>b</sub> = 2.7 kΩ	1/f <sub>MCK</sub> + 190 <small>Note 2</small>		ns
		1.8 V ≤ EV <sub>DD0</sub> < 3.3 V, 1.6 V ≤ V <sub>b</sub> ≤ 2.0 V <sup>Note 1</sup> , C <sub>b</sub> = 100 pF, R <sub>b</sub> = 5.5 kΩ	1/f <sub>MCK</sub> + 190 <small>Note 2</small>		ns
<R> Data hold time (transmission)	t <sub>HD:DAT</sub>	4.0 V ≤ EV <sub>DD0</sub> ≤ 5.5 V, 2.7 V ≤ V <sub>b</sub> ≤ 4.0 V, C <sub>b</sub> = 50 pF, R <sub>b</sub> = 2.7 kΩ	0	305	ns
		2.7 V ≤ EV <sub>DD0</sub> < 4.0 V, 2.3 V ≤ V <sub>b</sub> < 2.7 V, C <sub>b</sub> = 50 pF, R <sub>b</sub> = 2.7 kΩ	0	305	ns
		4.0 V ≤ EV <sub>DD0</sub> ≤ 5.5 V, 2.7 V ≤ V <sub>b</sub> ≤ 4.0 V, C <sub>b</sub> = 100 pF, R <sub>b</sub> = 2.8 kΩ	0	355	ns
		2.7 V ≤ EV <sub>DD0</sub> < 4.0 V, 2.3 V ≤ V <sub>b</sub> < 2.7 V, C <sub>b</sub> = 100 pF, R <sub>b</sub> = 2.7 kΩ	0	355	ns
		1.8 V ≤ EV <sub>DD0</sub> < 3.3 V, 1.6 V ≤ V <sub>b</sub> ≤ 2.0 V <sup>Note 1</sup> , C <sub>b</sub> = 100 pF, R <sub>b</sub> = 5.5 kΩ	0	405	ns

<R> **Notes 1.** Use it with EV<sub>DD0</sub> ≥ V<sub>b</sub>.

<R> **2.** Set the f<sub>MCK</sub> value to keep the hold time of SCLr = "L" and SCLr = "H".

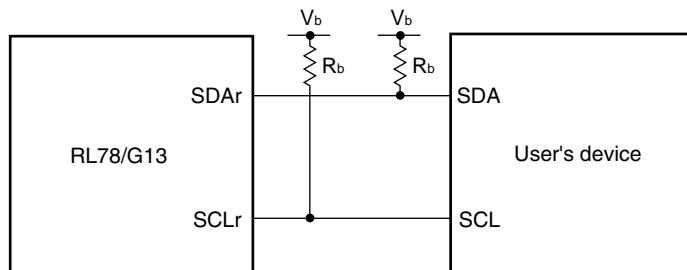
**Caution** Select the TTL input buffer and the N-ch open drain output (V<sub>DD</sub> tolerance) mode for the SDAr pin and the N-ch open drain output (V<sub>DD</sub> tolerance) mode for the SCLr pin by using port input mode register g (PIMg) and port output mode register g (POMg).

(Remarks is listed on the next page.)

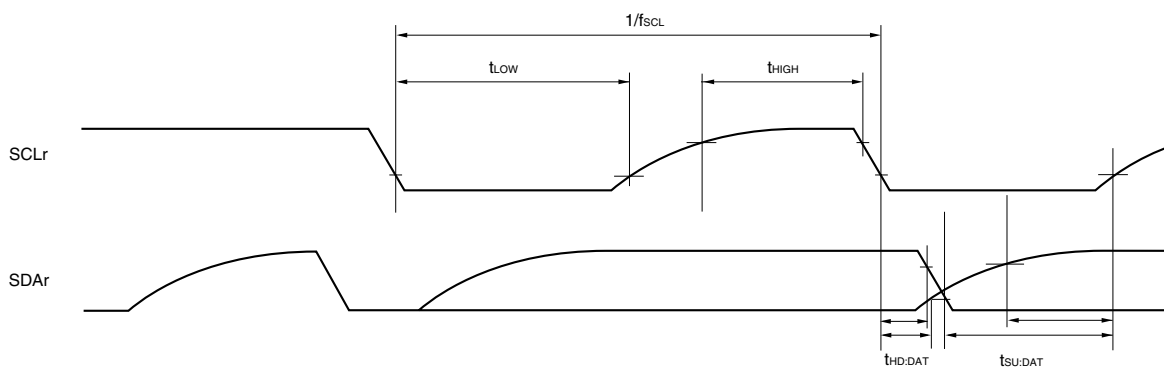


**Caution** The pins mounted depend on the product. Refer to 2.1.1 20-pin products to 2.1.14 128-pin products, and 2.1.15 Pins for each product (pins other than port pins).

**Simplified I<sup>2</sup>C mode connection diagram (during communication at different potential)**



**Simplified I<sup>2</sup>C mode serial transfer timing (during communication at different potential)**



**Caution** Select the TTL input buffer and the N-ch open drain output (V<sub>DD</sub> tolerance) mode for the SDAr pin and the N-ch open drain output (V<sub>DD</sub> tolerance) mode for the SCLr pin by using port input mode register g (PIMg) and port output mode register g (POMg).

- Remarks**
1. R<sub>b</sub>[Ω]: Communication line (SDAr, SCLr) pull-up resistance, C<sub>b</sub>[F]: Communication line (SDAr, SCLr) load capacitance, V<sub>b</sub>[V]: Communication line voltage
  2. r: IIC number (r = 00, 01, 10, 20, 30, 31), g: PIM, POM number (g = 0, 1, 4, 5, 8, 14)
  3. f<sub>MCK</sub>: Serial array unit operation clock frequency  
(Operation clock to be set by the CKSmn bit of serial mode register mn (SMRmn). m: Unit number, n: Channel number (mn = 00, 01, 02, 10, 12, 13))
  4. V<sub>IH</sub> and V<sub>IL</sub> below are observation points for the AC characteristics of the serial array unit when communicating at different potentials in simplified I<sup>2</sup>C mode mode.  
 4.0 V ≤ EV<sub>DD0</sub> ≤ 5.5 V, 2.7 V ≤ V<sub>b</sub> ≤ 4.0 V: V<sub>IH</sub> = 2.2 V, V<sub>IL</sub> = 0.8 V  
 2.7 V ≤ EV<sub>DD0</sub> < 4.0 V, 2.3 V ≤ V<sub>b</sub> ≤ 2.7 V: V<sub>IH</sub> = 2.0 V, V<sub>IL</sub> = 0.5 V  
 1.8 V ≤ EV<sub>DD0</sub> < 3.3 V, 1.6 V ≤ V<sub>b</sub> ≤ 2.0 V: V<sub>IH</sub> = 1.5 V, V<sub>IL</sub> = 0.32 V

<R>

**Caution** The pins mounted depend on the product. Refer to 2.1.1 20-pin products to 2.1.14 128-pin products, and 2.1.15 Pins for each product (pins other than port pins).

**29.6.2 Serial interface IICA**

( $T_A = -40$  to  $+85^\circ\text{C}$ ,  $1.6\text{ V} \leq EV_{DD0} = EV_{DD1} \leq V_{DD} \leq 5.5\text{ V}$ ,  $V_{SS} = EV_{SS0} = EV_{SS1} = 0\text{ V}$ )

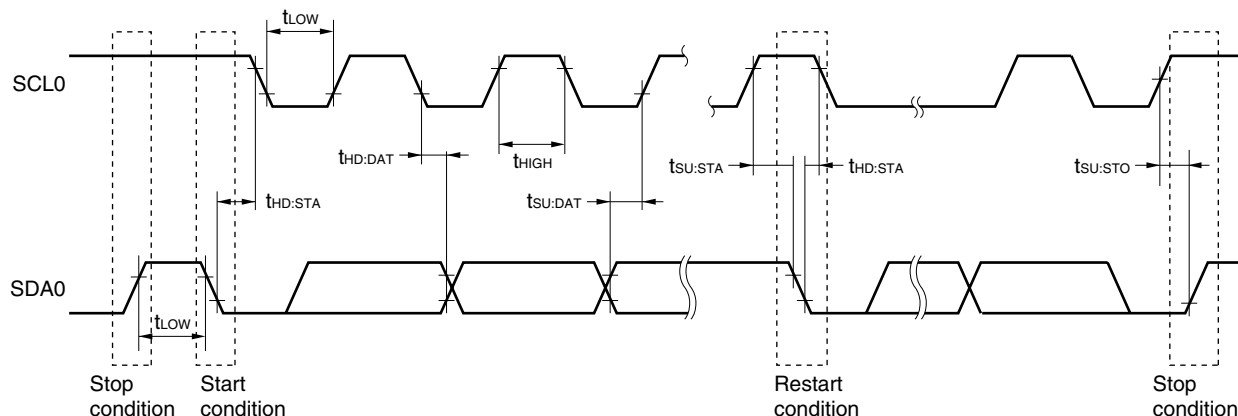
Parameter	Symbol	Conditions	Standard Mode		Fast Mode		Fast Mode Plus		Unit
			MIN.	MAX.	MIN.	MAX.	MIN.	MAX.	
SCLA0 clock frequency	$f_{SCL}$	Fast mode plus: $f_{CLK} \geq 10\text{ MHz}$	$2.7\text{ V} \leq EV_{DD0} \leq 5.5\text{ V}$				0	1000	kHz
		Fast mode: $f_{CLK} \geq 3.5\text{ MHz}$	$1.8\text{ V} \leq EV_{DD0} \leq 5.5\text{ V}$				0	400	kHz
		Normal mode: $f_{CLK} \geq 1\text{ MHz}$	$1.6\text{ V} \leq EV_{DD0} \leq 5.5\text{ V}$		0	100			kHz
Setup time of restart condition	$t_{SU:STA}$		4.7		0.6		0.26	$\mu\text{s}$	
Hold time <sup>Note 1</sup>	$t_{HD:STA}$		4.0		0.6		0.26	$\mu\text{s}$	
Hold time when SCLA0 = "L"	$t_{LOW}$		4.7		1.3		0.5	$\mu\text{s}$	
Hold time when SCLA0 = "H"	$t_{HIGH}$		4.0		0.6		0.26	$\mu\text{s}$	
Data setup time (reception)	$t_{SU:DAT}$		250		100		50	ns	
Data hold time (transmission) <sup>Note 2</sup>	$t_{HD:DAT}$		0	3.45	0	0.9	0	$\mu\text{s}$	
Setup time of stop condition	$t_{SU:STO}$		4.0		0.6		0.26	$\mu\text{s}$	
Bus-free time	$t_{BUF}$		4.7		1.3		0.5	$\mu\text{s}$	

- Notes**
- The first clock pulse is generated after this period when the start/restart condition is detected.
  - The maximum value (MAX.) of  $t_{HD:DAT}$  is during normal transfer and a wait state is inserted in the  $\overline{\text{ACK}}$  (acknowledge) timing.

**Remark** The maximum value of  $C_b$  (communication line capacitance) and the value of  $R_b$  (communication line pull-up resistor) at that time in each mode are as follows.

- Standard mode:  $C_b = 400\text{ pF}$ ,  $R_b = 2.7\text{ k}\Omega$
- Fast mode:  $C_b = 320\text{ pF}$ ,  $R_b = 1.1\text{ k}\Omega$
- Fast mode plus:  $C_b = 120\text{ pF}$ ,  $R_b = 1.1\text{ k}\Omega$

**IICA serial transfer timing**



**Caution** The pins mounted depend on the product. Refer to 2.1.1 20-pin products to 2.1.14 128-pin products, and 2.1.15 Pins for each product (pins other than port pins).

### 29.6.3 On-chip debug (UART)

( $T_A = -40$  to  $+85^\circ\text{C}$ ,  $1.8\text{ V} \leq EV_{DD0} = EV_{DD1} \leq V_{DD} \leq 5.5\text{ V}$ ,  $V_{SS} = EV_{SS0} = EV_{SS1} = 0\text{ V}$ )

Parameter	Symbol	Conditions	MIN.	TYP.	MAX.	Unit
Transfer rate			115.2 k		1 M	bps

## 29.7 Analog Characteristics

### <R> 29.7.1 A/D converter characteristics

(1) When  $AV_{REF(+)} = AV_{REFP}/ANI0$  ( $ADREFP1 = 0$ ,  $ADREFP0 = 1$ ),  $AV_{REF(-)} = AV_{REFM}/ANI1$  ( $ADREFM = 1$ ), target ANI pin : ANI2 to ANI14 (supply ANI pin to  $V_{DD}$ )

( $T_A = -40$  to  $+85^\circ\text{C}$ ,  $1.6\text{ V} \leq EV_{DD0} = EV_{DD1} \leq V_{DD} \leq 5.5\text{ V}$ ,  $V_{SS} = EV_{SS0} = EV_{SS1} = 0\text{ V}$ , Reference voltage (+) =  $AV_{REFP}$ , Reference voltage (-) =  $AV_{REFM} = 0\text{ V}$ )

Parameter	Symbol	Conditions	MIN.	TYP.	MAX.	Unit	
Resolution	RES		8		10	bit	
Overall error <sup>Notes 1, 2</sup>	AINL	10-bit resolution $AV_{REFP} = V_{DD}$	$1.8\text{ V} \leq V_{DD} \leq 5.5\text{ V}$		1.2	$\pm 3.5$	LSB
			$1.6\text{ V} \leq V_{DD} \leq 5.5\text{ V}$		1.2	$\pm 7.0$	LSB
Conversion time	tCONV	10-bit resolution $AV_{REFP} = V_{DD}$	$3.6\text{ V} \leq V_{DD} \leq 5.5\text{ V}$	2.125		39	$\mu\text{s}$
			$2.7\text{ V} \leq V_{DD} \leq 5.5\text{ V}$	3.1875		39	$\mu\text{s}$
			$1.8\text{ V} \leq V_{DD} \leq 5.5\text{ V}$	17		39	$\mu\text{s}$
			$1.6\text{ V} \leq V_{DD} \leq 5.5\text{ V}$	57		95	$\mu\text{s}$
Zero-scale error <sup>Notes 1, 2</sup>	EZS	10-bit resolution $AV_{REFP} = V_{DD}$	$1.8\text{ V} \leq V_{DD} \leq 5.5\text{ V}$			$\pm 0.25$	%FSR
			$1.6\text{ V} \leq V_{DD} \leq 5.5\text{ V}$			$\pm 0.50$	%FSR
Full-scale error <sup>Notes 1, 2</sup>	EFS	10-bit resolution $AV_{REFP} = V_{DD}$	$1.8\text{ V} \leq V_{DD} \leq 5.5\text{ V}$			$\pm 0.25$	%FSR
			$1.6\text{ V} \leq V_{DD} \leq 5.5\text{ V}$			$\pm 0.50$	%FSR
Integral linearity error <sup>Note 1</sup>	ILE	10-bit resolution $AV_{REFP} = V_{DD}$	$1.8\text{ V} \leq V_{DD} \leq 5.5\text{ V}$			$\pm 2.5$	LSB
			$1.6\text{ V} \leq V_{DD} \leq 5.5\text{ V}$			$\pm 5.0$	LSB
Differential linearity error <sup>Note 1</sup>	DLE	10-bit resolution $AV_{REFP} = V_{DD}$	$1.8\text{ V} \leq V_{DD} \leq 5.5\text{ V}$			$\pm 1.5$	LSB
			$1.6\text{ V} \leq V_{DD} \leq 5.5\text{ V}$			$\pm 2.0$	LSB
Reference voltage (+)	$AV_{REFP}$		1.6		$V_{DD}$	V	
Analog input voltage	$V_{AIN}$		0		$AV_{REFP}$	V	
	$V_{BGR}$	$2.4\text{ V} \leq V_{DD} \leq 5.5\text{ V}$	1.38	1.45	1.5	V	

**Notes** 1. Excludes quantization error ( $\pm 1/2$  LSB).

2. This value is indicated as a ratio (%FSR) to the full-scale value.

**Caution** The pins mounted depend on the product. Refer to 2.1.1 20-pin products to 2.1.14 128-pin products, and 2.1.15 Pins for each product (pins other than port pins).

(2) When  $AV_{REF(+)} = AV_{REFP}/ANI0$  ( $ADREFP1 = 0$ ,  $ADREFP0 = 1$ ),  $AV_{REF(-)} = AV_{REFM}/ANI1$  ( $ADREFM = 1$ ), target ANI pin : ANI16 to ANI26 (supply ANI pin to  $EV_{DD0}$ )

( $T_A = -40$  to  $+85^\circ\text{C}$ ,  $1.6\text{ V} \leq EV_{DD0} = EV_{DD1} \leq V_{DD} \leq 5.5\text{ V}$ ,  $V_{SS} = EV_{SS0} = EV_{SS1} = 0\text{ V}$ , Reference voltage (+) =  $AV_{REFP}$ , Reference voltage (-) =  $AV_{REFM}$ )

Parameter	Symbol	Conditions	MIN.	TYP.	MAX.	Unit	
Resolution	$R_{ES}$		8		10	bit	
Overall error <sup>Notes 1, 2</sup>	AINL	10-bit resolution $AV_{REFP} = V_{DD}$	$1.8\text{ V} \leq V_{DD} \leq 5.5\text{ V}$		1.2	$\pm 5.0$	LSB
			$1.6\text{ V} \leq V_{DD} \leq 5.5\text{ V}$		1.2	$\pm 8.5$	LSB
Conversion time	$t_{CONV}$	10-bit resolution $AV_{REFP} = V_{DD}$	$3.6\text{ V} \leq V_{DD} \leq 5.5\text{ V}$	2.125		39	$\mu\text{S}$
			$2.7\text{ V} \leq V_{DD} \leq 5.5\text{ V}$	3.1875		39	$\mu\text{S}$
			$1.8\text{ V} \leq V_{DD} \leq 5.5\text{ V}$	17		39	$\mu\text{S}$
			$1.6\text{ V} \leq V_{DD} \leq 5.5\text{ V}$	57		95	$\mu\text{S}$
Zero-scale error <sup>Notes 1, 2</sup>	EZS	10-bit resolution $AV_{REFP} = V_{DD}$	$1.8\text{ V} \leq V_{DD} \leq 5.5\text{ V}$			$\pm 0.35$	%FSR
			$1.6\text{ V} \leq V_{DD} \leq 5.5\text{ V}$			$\pm 0.60$	%FSR
Full-scale error <sup>Notes 1, 2</sup>	EFS	10-bit resolution $AV_{REFP} = V_{DD}$	$1.8\text{ V} \leq V_{DD} \leq 5.5\text{ V}$			$\pm 0.35$	%FSR
			$1.6\text{ V} \leq V_{DD} \leq 5.5\text{ V}$			$\pm 0.60$	%FSR
Integral linearity error <sup>Note 1</sup>	ILE	10-bit resolution $AV_{REFP} = V_{DD}$	$1.8\text{ V} \leq V_{DD} \leq 5.5\text{ V}$			$\pm 3.5$	LSB
			$1.6\text{ V} \leq V_{DD} \leq 5.5\text{ V}$			$\pm 6.0$	LSB
Differential linearity error <sup>Note 1</sup>	DLE	10-bit resolution $AV_{REFP} = V_{DD}$	$1.8\text{ V} \leq V_{DD} \leq 5.5\text{ V}$			$\pm 2.0$	LSB
			$1.6\text{ V} \leq V_{DD} \leq 5.5\text{ V}$			$\pm 2.5$	LSB
Reference voltage (+)	$AV_{REFP}$		1.6		$V_{DD}$	V	
Analog input voltage	$V_{AIN}$		0		$AV_{REFP}$ and $EV_{DD0}$	V	
	$V_{BGR}$	$2.4\text{ V} \leq V_{DD} \leq 5.5\text{ V}$	1.38	1.45	1.5	V	

**Notes** 1. Excludes quantization error ( $\pm 1/2$  LSB).

2. This value is indicated as a ratio (%FSR) to the full-scale value.

**Caution** The pins mounted depend on the product. Refer to 2.1.1 20-pin products to 2.1.14 128-pin products, and 2.1.15 Pins for each product (pins other than port pins).

(3) When  $AV_{REF(+)} = V_{DD}$  (ADREFP1 = 0, ADREFP0 = 0),  $AV_{REF(-)} = V_{SS}$  (ADREFM = 0), target ANI pin : ANI0 to ANI14, ANI16 to ANI26

( $T_A = -40$  to  $+85^\circ\text{C}$ ,  $1.6\text{ V} \leq EV_{DD0} = EV_{DD1} \leq V_{DD} \leq 5.5\text{ V}$ ,  $V_{SS} = EV_{SS0} = EV_{SS1} = 0\text{ V}$ , Reference voltage (+) =  $V_{DD}$ , Reference voltage (-) =  $V_{SS}$ )

Parameter	Symbol	Conditions		MIN.	TYP.	MAX.	Unit
Resolution	$R_{ES}$			8		10	bit
Overall error <sup>Notes 1, 2</sup>	AINL	10-bit resolution	$1.8\text{ V} \leq V_{DD} \leq 5.5\text{ V}$		1.2	$\pm 7.0$	LSB
			$1.6\text{ V} \leq V_{DD} \leq 5.5\text{ V}$		1.2	$\pm 10.5$	LSB
Conversion time	$t_{CONV}$	10-bit resolution	$3.6\text{ V} \leq V_{DD} \leq 5.5\text{ V}$	2.125		39	$\mu\text{S}$
			$2.7\text{ V} \leq V_{DD} \leq 5.5\text{ V}$	3.1875		39	$\mu\text{S}$
			$1.8\text{ V} \leq V_{DD} \leq 5.5\text{ V}$	17		39	$\mu\text{S}$
			$1.6\text{ V} \leq V_{DD} \leq 5.5\text{ V}$	57		95	$\mu\text{S}$
Zero-scale error <sup>Notes 1, 2</sup>	EVS	10-bit resolution	$1.8\text{ V} \leq V_{DD} \leq 5.5\text{ V}$			$\pm 0.60$	%FSR
			$1.6\text{ V} \leq V_{DD} \leq 5.5\text{ V}$			$\pm 0.85$	%FSR
Full-scale error <sup>Notes 1, 2</sup>	EFS	10-bit resolution	$1.8\text{ V} \leq V_{DD} \leq 5.5\text{ V}$			$\pm 0.60$	%FSR
			$1.6\text{ V} \leq V_{DD} \leq 5.5\text{ V}$			$\pm 0.85$	%FSR
Integral linearity error <sup>Note 1</sup>	ILE	10-bit resolution	$1.8\text{ V} \leq V_{DD} \leq 5.5\text{ V}$			$\pm 4.0$	LSB
			$1.6\text{ V} \leq V_{DD} \leq 5.5\text{ V}$			$\pm 6.5$	LSB
Differential linearity error <sup>Note 1</sup>	DLE	10-bit resolution	$1.8\text{ V} \leq V_{DD} \leq 5.5\text{ V}$			$\pm 2.0$	LSB
			$1.6\text{ V} \leq V_{DD} \leq 5.5\text{ V}$			$\pm 2.5$	LSB
Analog input voltage	$V_{AIN}$	ANI0 to ANI14		0		$V_{DD}$	V
		ANI16 to ANI26		0		$EV_{DD0}$	V
	$V_{BGR}$	$2.4\text{ V} \leq V_{DD} \leq 5.5\text{ V}$		1.38	1.45	1.5	V

**Notes** 1. Excludes quantization error ( $\pm 1/2$  LSB).

2. This value is indicated as a ratio (%FSR) to the full-scale value.

**Caution** The pins mounted depend on the product. Refer to 2.1.1 20-pin products to 2.1.14 128-pin products, and 2.1.15 Pins for each product (pins other than port pins).

(4) When  $AV_{REF(+)}$  = Internal reference voltage (ADREFP1 = 1, ADREFP0 = 0),  $AV_{REF(-)}$  =  $AV_{REFM}/ANI1$  (ADREFM = 1), target ANI pin : ANI0 to ANI14, ANI16 to ANI26

( $T_A = -40$  to  $+85^\circ\text{C}$ ,  $1.6\text{ V} \leq EV_{DD0} = EV_{DD1} \leq V_{DD} \leq 5.5\text{ V}$ ,  $V_{SS} = EV_{SS0} = EV_{SS1} = 0\text{ V}$ , Reference voltage (+) =  $V_{BGR}$ , Reference voltage (-) =  $AV_{REFM} = 0\text{ V}$ )

Parameter	Symbol	Conditions		MIN.	TYP.	MAX.	Unit
Resolution	$R_{ES}$			8			bit
Conversion time	$t_{CONV}$	8-bit resolution	$2.4\text{ V} \leq V_{DD} \leq 5.5\text{ V}$	17		39	$\mu\text{s}$
Zero-scale error <sup>Notes 1, 2</sup>	EZS	8-bit resolution	$2.4\text{ V} \leq V_{DD} \leq 5.5\text{ V}$			$\pm 0.60$	%FSR
Integral linearity error <sup>Note 1</sup>	ILE	8-bit resolution	$2.4\text{ V} \leq V_{DD} \leq 5.5\text{ V}$			$\pm 2.0$	LSB
Differential linearity error <sup>Note 1</sup>	DLE	8-bit resolution	$2.4\text{ V} \leq V_{DD} \leq 5.5\text{ V}$			$\pm 1.0$	LSB
Reference voltage (+)	$V_{BGR}$			1.38	1.45	1.5	V
Reference voltage (-)	$AV_{REFM}$			$V_{SS}$			V
Analog input voltage	$V_{AIN}$			0		$V_{BGR}$	V

**Notes** 1. Excludes quantization error ( $\pm 1/2$  LSB).

2. This value is indicated as a ratio (%FSR) to the full-scale value.

**Caution** The pins mounted depend on the product. Refer to 2.1.1 20-pin products to 2.1.14 128-pin products, and 2.1.15 Pins for each product (pins other than port pins).

### 29.7.2 Temperature sensor characteristics

( $T_A = -40$  to  $+85^\circ\text{C}$ ,  $2.4\text{ V} \leq EV_{DD0} = EV_{DD1} \leq V_{DD} \leq 5.5\text{ V}$ ,  $V_{SS} = EV_{SS0} = EV_{SS1} = 0\text{ V}$ )

	Parameter	Symbol	Conditions	MIN.	TYP.	MAX.	Unit
<R>	Temperature sensor output voltage	$V_{TMPS25}$	Setting ADS register = 80H, $T_A = +25^\circ\text{C}$		1.05		V
<R>	Reference output voltage	$V_{CONST}$	Setting ADS register = 81H	1.38	1.45	1.5	V
<R>	Temperature coefficient	$F_{VTMPS}$	Temperature sensor that depends on the temperature		-3.6		mV/C
	Operation stabilization wait time	$t_{AMP}$				5	$\mu\text{s}$

### 29.7.3 POR circuit characteristics

( $T_A = -40$  to  $+85^\circ\text{C}$ ,  $V_{SS} = 0\text{ V}$ )

	Parameter	Symbol	Conditions	MIN.	TYP.	MAX.	Unit
<R>	Detection voltage	$V_{POR}$	Power supply rise time	1.48	1.51	1.54	V
<R>		$V_{PDR}$	Power supply fall time	1.47	1.50	1.53	V
	Minimum pulse width	$T_{PW}$		300			$\mu\text{s}$
	Detection delay time					350	$\mu\text{s}$

**Caution** The pins mounted depend on the product. Refer to 2.1.1 20-pin products to 2.1.14 128-pin products, and 2.1.15 Pins for each product (pins other than port pins).

#### 29.7.4 LVD circuit characteristics

##### LVD Detection Voltage of Reset Mode and Interrupt Mode

( $T_A = -40$  to  $+85^\circ\text{C}$ ,  $V_{PDR} \leq EV_{DD0} = EV_{DD1} \leq V_{DD} \leq 5.5$  V,  $V_{SS} = EV_{SS0} = EV_{SS1} = 0$  V)

Parameter		Symbol	Conditions	MIN.	TYP.	MAX.	Unit
Detection voltage	Supply voltage level	V <sub>LVD0</sub>	Power supply rise time	3.98	4.06	4.14	V
			Power supply fall time	3.90	3.98	4.06	V
		V <sub>LVD1</sub>	Power supply rise time	3.68	3.75	3.82	V
			Power supply fall time	3.60	3.67	3.74	V
		V <sub>LVD2</sub>	Power supply rise time	3.07	3.13	3.19	V
			Power supply fall time	3.00	3.06	3.12	V
		V <sub>LVD3</sub>	Power supply rise time	2.96	3.02	3.08	V
			Power supply fall time	2.90	2.96	3.02	V
		V <sub>LVD4</sub>	Power supply rise time	2.86	2.92	2.97	V
			Power supply fall time	2.80	2.86	2.91	V
		V <sub>LVD5</sub>	Power supply rise time	2.76	2.81	2.87	V
			Power supply fall time	2.70	2.75	2.81	V
		V <sub>LVD6</sub>	Power supply rise time	2.66	2.71	2.76	V
			Power supply fall time	2.60	2.65	2.70	V
		V <sub>LVD7</sub>	Power supply rise time	2.56	2.61	2.66	V
			Power supply fall time	2.50	2.55	2.60	V
		V <sub>LVD8</sub>	Power supply rise time	2.45	2.50	2.55	V
			Power supply fall time	2.40	2.45	2.50	V
		V <sub>LVD9</sub>	Power supply rise time	2.05	2.09	2.13	V
			Power supply fall time	2.00	2.04	2.08	V
		V <sub>LVD10</sub>	Power supply rise time	1.94	1.98	2.02	V
			Power supply fall time	1.90	1.94	1.98	V
		V <sub>LVD11</sub>	Power supply rise time	1.84	1.88	1.91	V
			Power supply fall time	1.80	1.84	1.87	V
		V <sub>LVD12</sub>	Power supply rise time	1.74	1.77	1.81	V
			Power supply fall time	1.70	1.73	1.77	V
V <sub>LVD13</sub>	Power supply rise time	1.64	1.67	1.70	V		
	Power supply fall time	1.60	1.63	1.66	V		
Minimum pulse width		t <sub>LW</sub>		300			μs
Detection delay time		t <sub>LD</sub>				300	μs

**Remark**  $V_{LVD(n-1)} > V_{LVDn}$ : n = 1 to 13



**Caution** The pins mounted depend on the product. Refer to 2.1.1 20-pin products to 2.1.14 128-pin products, and 2.1.15 Pins for each product (pins other than port pins).

### LVD Detection Voltage of Interrupt & Reset Mode

( $T_A = -40$  to  $+85^\circ\text{C}$ ,  $V_{PDR} \leq EV_{DD0} = EV_{DD1} \leq V_{DD} \leq 5.5$  V,  $V_{SS} = EV_{SS0} = EV_{SS1} = 0$  V)

Parameter	Symbol	Conditions	MIN.	TYP.	MAX.	Unit	
Interrupt and reset mode	$V_{LVD13}$	$V_{POC0}, V_{POC1}, V_{POC2} = 0, 0, 0$ , falling reset voltage: 1.6 V	1.60	1.63	1.66	V	
	$V_{LVD12}$	$LVIS0, LVIS1 = 1, 0$ (+0.1 V)	Rising release reset voltage	1.74	1.77	1.81	V
			Falling interrupt voltage	1.70	1.73	1.77	V
	$V_{LVD11}$	$LVIS0, LVIS1 = 0, 1$ (+0.2 V)	Rising release reset voltage	1.84	1.88	1.91	V
			Falling interrupt voltage	1.80	1.84	1.87	V
	$V_{LVD4}$	$LVIS0, LVIS1 = 0, 0$ (+1.2 V)	Rising release reset voltage	2.86	2.92	2.97	V
			Falling interrupt voltage	2.80	2.86	2.91	V
	$V_{LVD11}$	$V_{POC0}, V_{POC1}, V_{POC2} = 0, 0, 1$ , falling reset voltage: 1.8 V	1.80	1.84	1.87	V	
	$V_{LVD10}$	$LVIS0, LVIS1 = 1, 0$ (+0.1 V)	Rising release reset voltage	1.94	1.98	2.02	V
			Falling interrupt voltage	1.90	1.94	1.98	V
	$V_{LVD9}$	$LVIS0, LVIS1 = 0, 1$ (+0.2 V)	Rising release reset voltage	2.05	2.09	2.13	V
			Falling interrupt voltage	2.00	2.04	2.08	V
	$V_{LVD2}$	$LVIS0, LVIS1 = 0, 0$ (+1.2 V)	Rising release reset voltage	3.07	3.13	3.19	V
			Falling interrupt voltage	3.00	3.06	3.12	V
	$V_{LVD8}$	$V_{POC0}, V_{POC1}, V_{POC2} = 0, 1, 0$ , falling reset voltage: 2.4 V	2.40	2.45	2.50	V	
	$V_{LVD7}$	$LVIS0, LVIS1 = 1, 0$ (+0.1 V)	Rising release reset voltage	2.56	2.61	2.66	V
Falling interrupt voltage			2.50	2.55	2.60	V	
$V_{LVD6}$	$LVIS0, LVIS1 = 0, 1$ (+0.2 V)	Rising release reset voltage	2.66	2.71	2.76	V	
		Falling interrupt voltage	2.60	2.65	2.70	V	
$V_{LVD1}$	$LVIS0, LVIS1 = 0, 0$ (+1.2 V)	Rising release reset voltage	3.68	3.75	3.82	V	
		Falling interrupt voltage	3.60	3.67	3.74	V	
$V_{LVD5}$	$V_{POC0}, V_{POC1}, V_{POC2} = 0, 1, 1$ , falling reset voltage: 2.7 V	2.70	2.75	2.81	V		
$V_{LVD4}$	$LVIS0, LVIS1 = 1, 0$ (+0.1 V)	Rising release reset voltage	2.86	2.92	2.97	V	
		Falling interrupt voltage	2.80	2.86	2.91	V	
$V_{LVD3}$	$LVIS0, LVIS1 = 0, 1$ (+0.2 V)	Rising release reset voltage	2.96	3.02	3.08	V	
		Falling interrupt voltage	2.90	2.96	3.02	V	
$V_{LVD0}$	$LVIS0, LVIS1 = 0, 0$ (+1.2 V)	Rising release reset voltage	3.98	4.06	4.14	V	
		Falling interrupt voltage	3.90	3.98	4.06	V	

**Caution** The pins mounted depend on the product. Refer to 2.1.1 20-pin products to 2.1.14 128-pin products, and 2.1.15 Pins for each product (pins other than port pins).

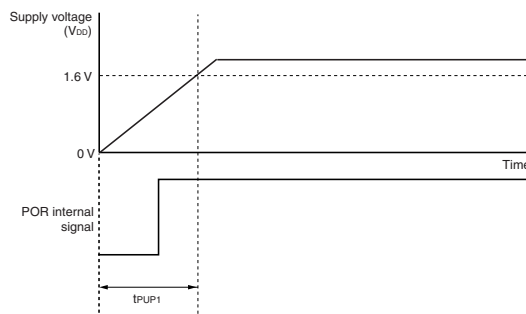
<R> **Supply Voltage Rise Time** ( $T_A = -40$  to  $+85^\circ\text{C}$ ,  $V_{SS} = 0$  V)

Parameter	Symbol	Conditions	MIN.	TYP.	MAX.	Unit
Maximum time to rise to 1.6 V ( $V_{DD}$ (MIN.)) <sup>Note</sup> ( $V_{DD}$ : 0 V $\rightarrow$ 1.6 V)	$t_{PUP1}$	When $\overline{\text{RESET}}$ input is not used			3.2	ms

**Note** Make sure to raise the power supply in a shorter time than this.

**Supply Voltage Rise Time Timing**

- When RESET pin input is not used



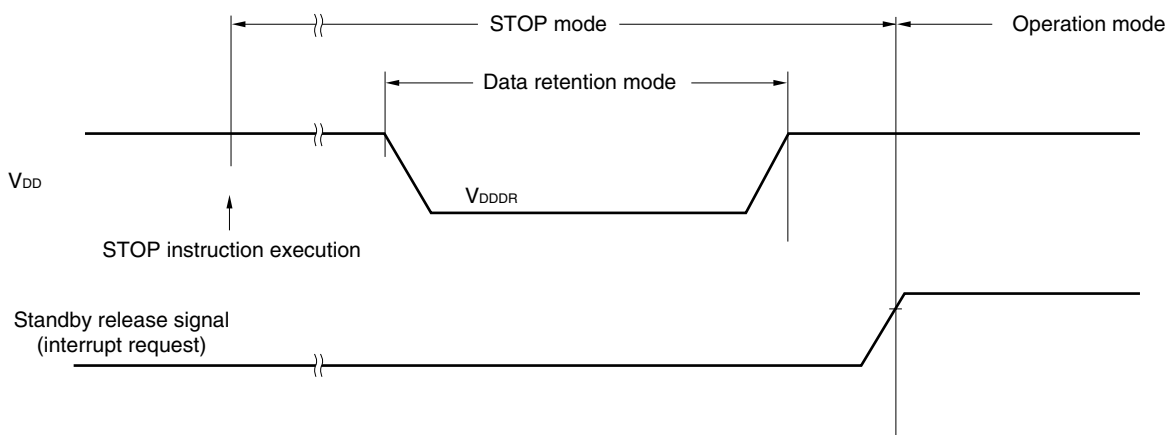
**Caution** The pins mounted depend on the product. Refer to 2.1.1 20-pin products to 2.1.14 128-pin products, and 2.1.15 Pins for each product (pins other than port pins).

### 29.8 Data Memory STOP Mode Low Supply Voltage Data Retention Characteristics

( $T_A = -40$  to  $+85^\circ\text{C}$ )

Parameter	Symbol	Conditions	MIN.	TYP.	MAX.	Unit
<R> Data retention supply voltage	$V_{DDDR}$		1.47 <sup>Note</sup>		5.5	V

**Note** The value depends on the POR detection voltage. When the voltage drops, the data is retained before a POR reset is effected, but data is not retained when a POR reset is effected.



### 29.9 Flash Memory Programming Characteristics

( $T_A = -40$  to  $+85^\circ\text{C}$ ,  $1.8\text{ V} \leq EV_{DD0} = EV_{DD1} \leq V_{DD} \leq 5.5\text{ V}$ ,  $V_{SS} = EV_{SS0} = EV_{SS1} = 0\text{ V}$ )

Parameter	Symbol	Conditions	MIN.	TYP.	MAX.	Unit
CPU/peripheral hardware clock frequency	$f_{CLK}$	$1.8\text{ V} \leq V_{DD} \leq 5.5\text{ V}$	1		32	MHz
<R> Number of code flash rewrites <small>Note 1</small>	$C_{enwr}$	1 erase + 1 write after the erase is regarded as 1 rewrite. The retaining years are until next rewrite after the rewrite.	Retained for 20 years (Self/serial programming) <sup>Note 2</sup>	1,000		Times
<R> Number of data flash rewrites			Retained for 1 years (Self/serial programming) <sup>Note 2</sup>		1,000,000	
<R>			Retained for 5 years (Self/serial programming) <sup>Note 2</sup>	100,000		

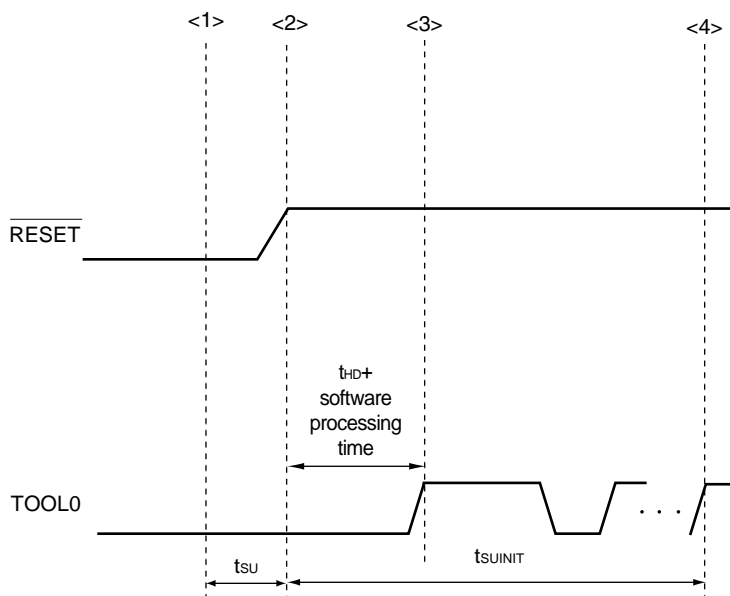
- Notes**
- 128-pin products, and flash ROM: 384 to 512 KB of 44- to 100-pin products, these specifications show target values, which may change after device evaluation.
  - When using flash memory programmer and Renesas Electronics self programming library

**Remark** When updating data multiple times, use the flash memory as one for updating data.

**Caution** The pins mounted depend on the product. Refer to 2.1.1 20-pin products to 2.1.14 128-pin products, and 2.1.15 Pins for each product (pins other than port pins).

**29.10 Timing Specs for Switching Modes**

Parameter	Symbol	Conditions	MIN.	TYP.	MAX.	Unit
<R> How long from when a pin reset ends until the initial communication settings are specified	$t_{SUIINIT}$	POR and LVD reset must end before the pin reset ends.			100	ms
<R> How long from when the TOOL0 pin is placed at the low level until a pin reset ends	$t_{SU}$	POR and LVD reset must end before the pin reset ends.	10			$\mu s$
<R> How long the TOOL0 pin must be kept at the low level after a reset ends	$t_{HD}$	POR and LVD reset must end before the pin reset ends.	1			ms



- <1> The low level is input to the TOOL0 pin.
- <2> The pins reset ends (POR and LVD reset must end before the pin reset ends.).
- <3> The TOOL0 pin is set to the high level.
- <4> Setting of the flash memory programming mode by UART reception and complete the baud rate setting.

**Remark**  $t_{SUIINIT}$ : The segment shows that it is necessary to finish specifying the initial communication settings within 100 ms from when the external and internal resets end.

- <R>  $t_{SU}$ : How long from when the TOOL0 pin is placed at the low level until a pin reset ends
- $t_{HD}$ : How long to keep the TOOL0 pin at the low level from when the external and internal resets end

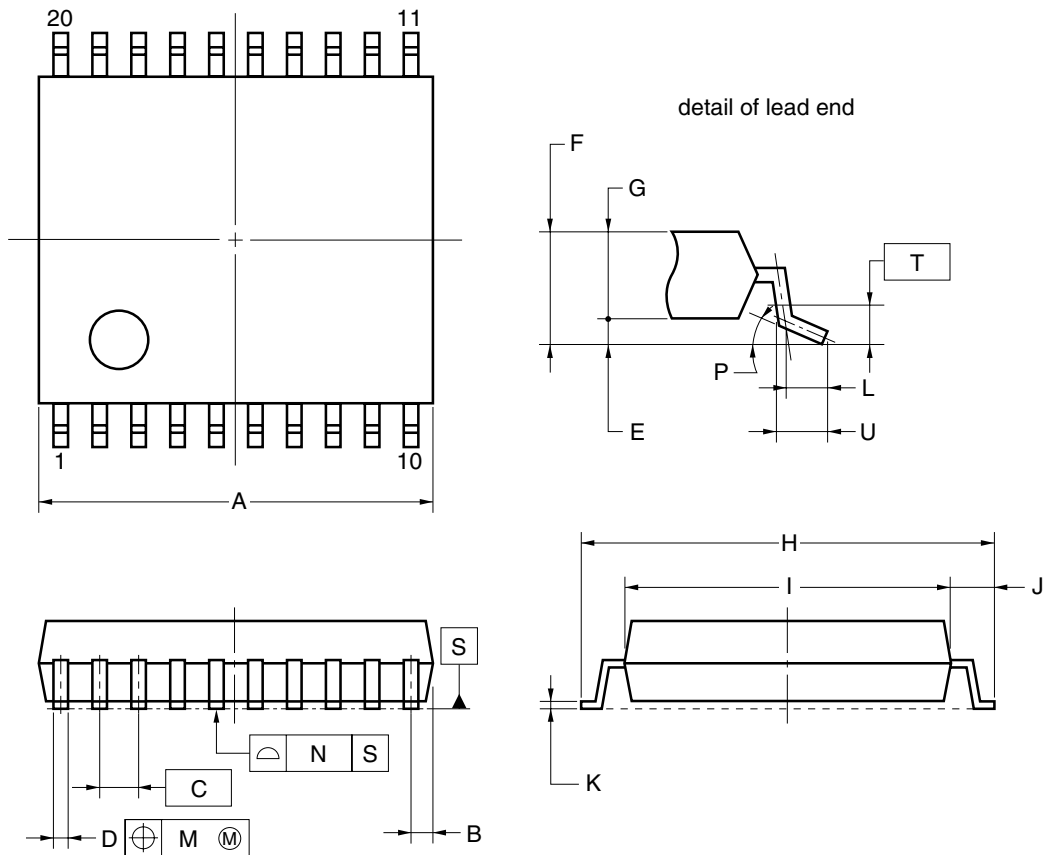
<R>

CHAPTER 30 PACKAGE DRAWINGS

30.1 20-pin products

R5F1006AASP, R5F1006CASP, R5F1006DASP, R5F1006EASP  
 R5F1016AASP, R5F1016CASP, R5F1016DASP, R5F1016EASP

20-PIN PLASTIC SSOP (7.62 mm (300))



NOTE

Each lead centerline is located within 0.13 mm of its true position (T.P.) at maximum material condition.

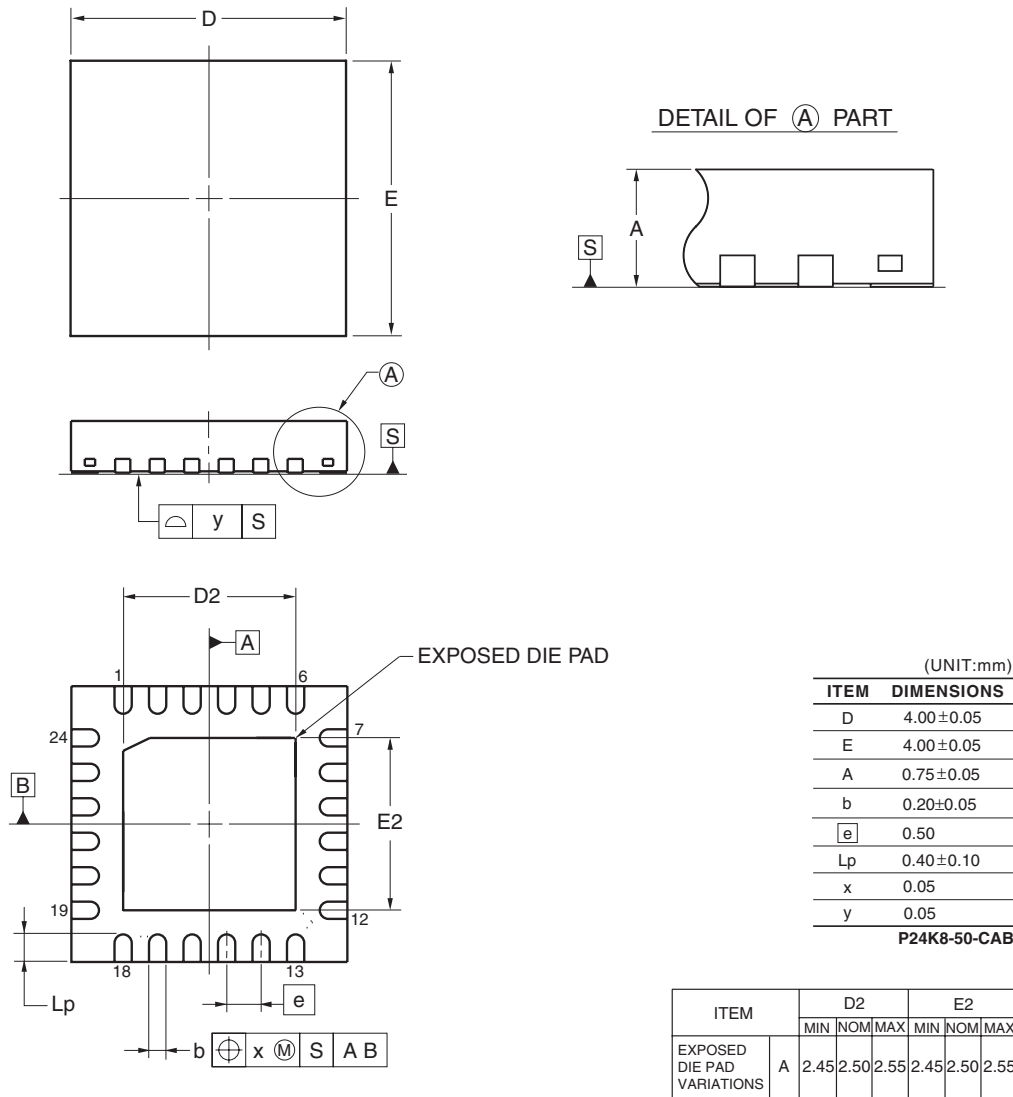
ITEM	MILLIMETERS
A	6.65±0.15
B	0.475 MAX.
C	0.65 (T.P.)
D	0.24 <sup>+0.08</sup> <sub>-0.07</sub>
E	0.1±0.05
F	1.3±0.1
G	1.2
H	8.1±0.2
I	6.1±0.2
J	1.0±0.2
K	0.17±0.03
L	0.5
M	0.13
N	0.10
P	3° <sup>+5°</sup> <sub>-3°</sub>
T	0.25
U	0.6±0.15

S20MC-65-5A4-2

30.2 24-pin products

R5F1007AANA, R5F1007CANA, R5F1007DANA, R5F1007EANA  
 R5F1017AANA, R5F1017CANA, R5F1017DANA, R5F1017EANA

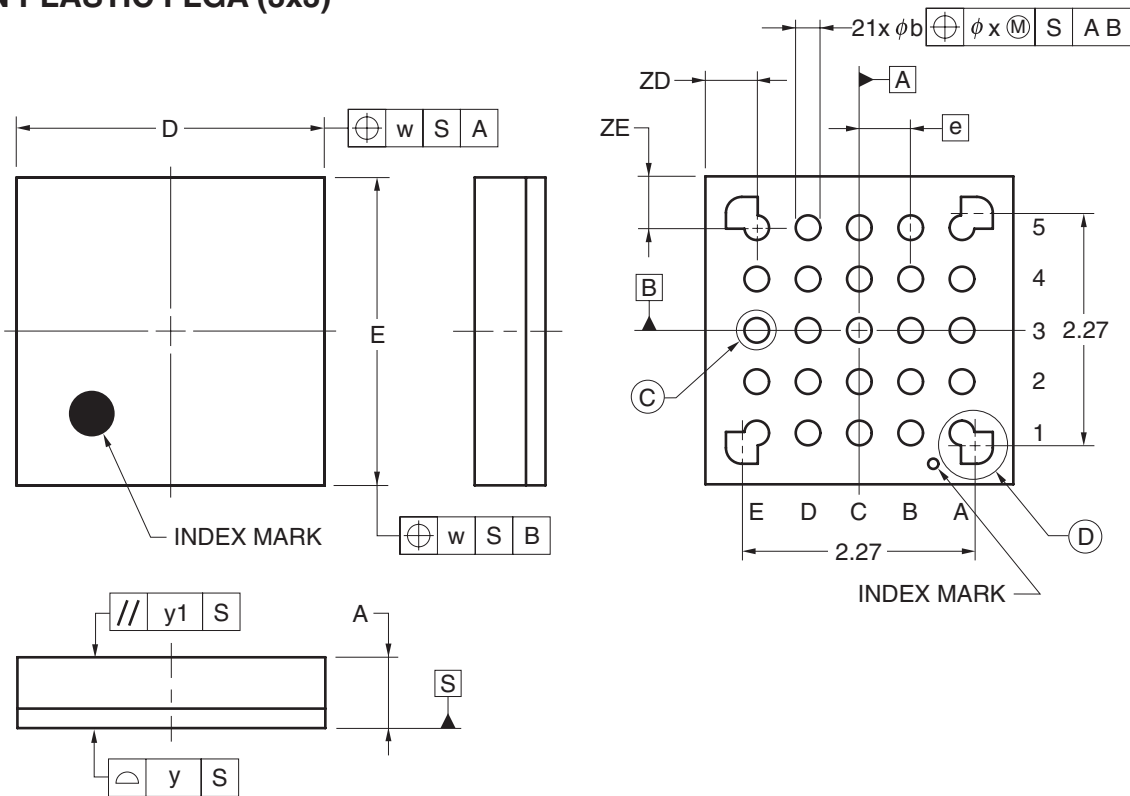
24-PIN PLASTIC WQFN(4x4)



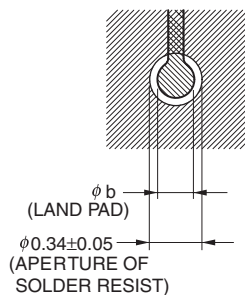
30.3 25-pin products

R5F1008AALA, R5F1008CALA, R5F1008DALA, R5F1008EALA  
 R5F1018AALA, R5F1018CALA, R5F1018DALA, R5F1018EALA

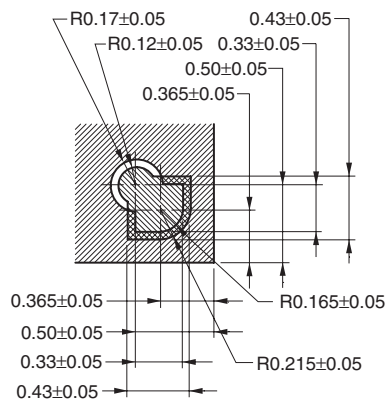
25-PIN PLASTIC FLGA (3x3)



DETAIL OF © PART



DETAIL OF ④ PART



(UNIT:mm)

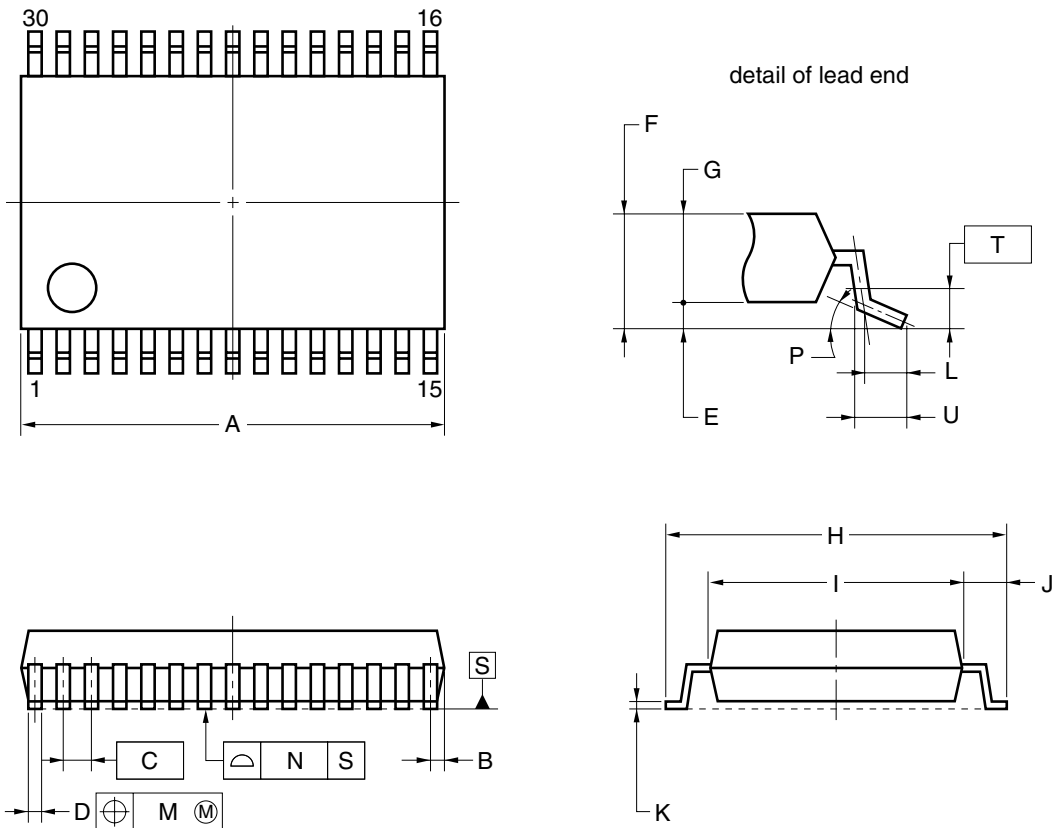
ITEM	DIMENSIONS
D	3.00±0.10
E	3.00±0.10
w	0.20
e	0.50
A	0.69±0.07
b	0.24±0.05
x	0.05
y	0.08
y1	0.20
ZD	0.50
ZE	0.50
P25FC-50-2N2-1	

©2010 Renesas Electronics Corporation. All rights reserved.

30.4 30-pin products

R5F100AAASP, R5F100ACASP, R5F100ADASP, R5F100AEASP, R5F100AFASP, R5F100AGASP  
 R5F101AAASP, R5F101ACASP, R5F101ADASP, R5F101AEASP, R5F101AFASP, R5F101AGASP

30-PIN PLASTIC SSOP (7.62 mm (300))



NOTE

Each lead centerline is located within 0.13 mm of its true position (T.P.) at maximum material condition.

ITEM	MILLIMETERS
A	9.85±0.15
B	0.45 MAX.
C	0.65 (T.P.)
D	0.24 <sup>+0.08</sup> <sub>-0.07</sub>
E	0.1±0.05
F	1.3±0.1
G	1.2
H	8.1±0.2
I	6.1±0.2
J	1.0±0.2
K	0.17±0.03
L	0.5
M	0.13
N	0.10
P	3° <sup>+5°</sup> <sub>-3°</sub>
T	0.25
U	0.6±0.15

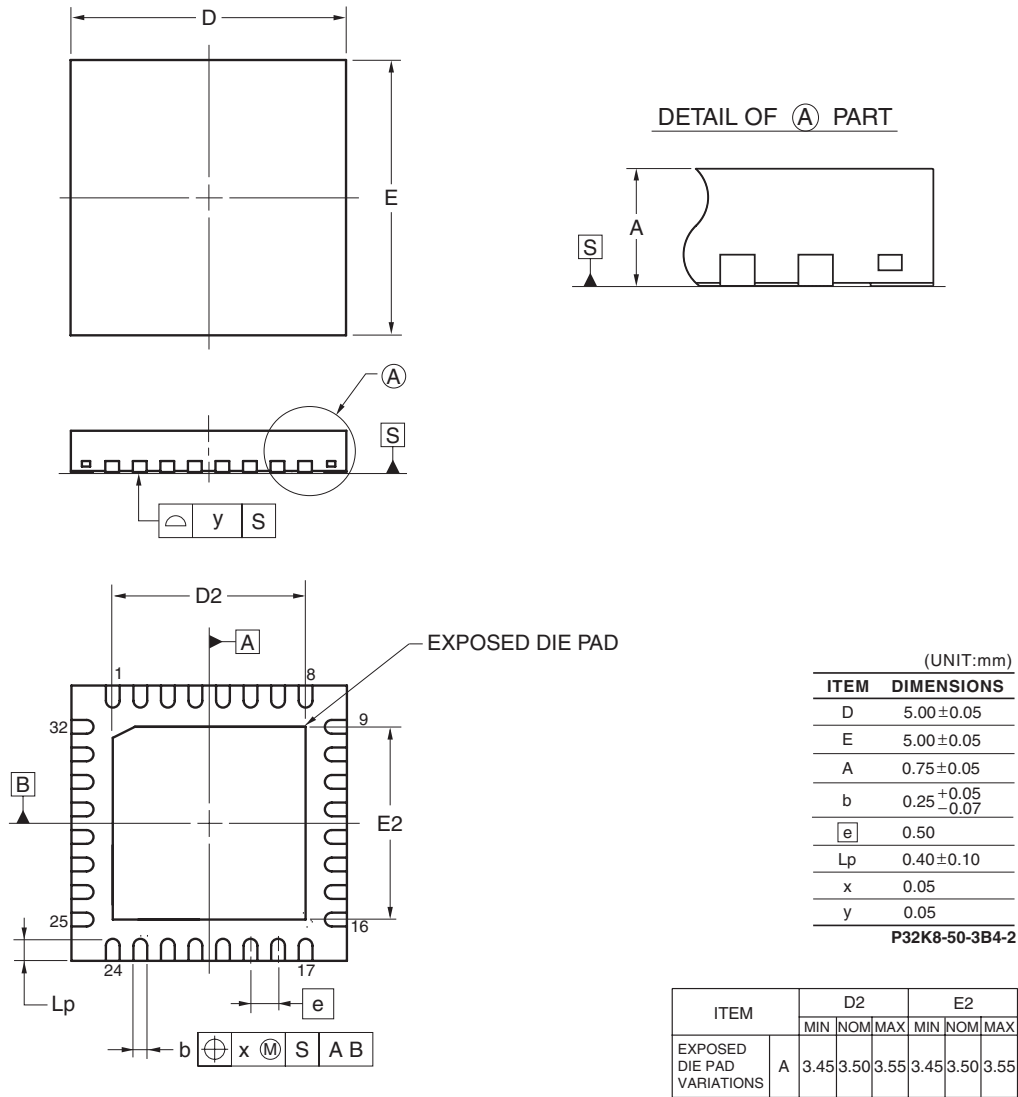
S30MC-65-5A4-2



30.5 32-pin products

R5F100BAANA, R5F100BCANA, R5F100BDANA, R5F100BEANA, R5F100BFANA, R5F100BGANA  
 R5F101BAANA, R5F101BCANA, R5F101BDANA, R5F101BEANA, R5F101BFANA, R5F101BGANA

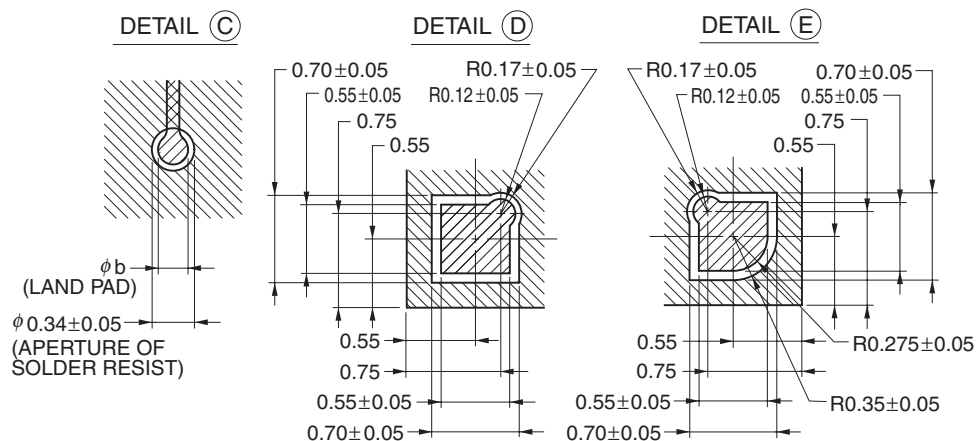
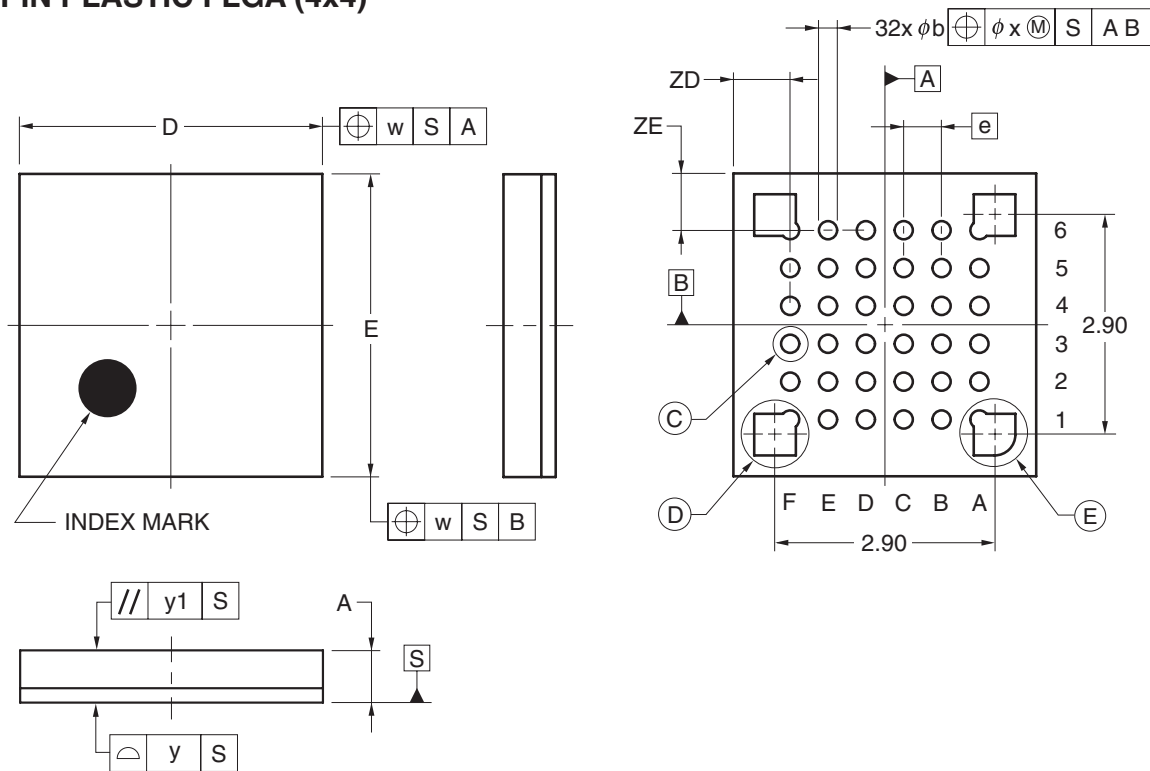
32-PIN PLASTIC WQFN(5x5)



30.6 36-pin products

R5F100CAALA, R5F100CCALA, R5F100CDALA, R5F100CEALA, R5F100CFALA, R5F100CGALA  
 R5F101CAALA, R5F101CCALA, R5F101CDALA, R5F101CEALA, R5F101CFALA, R5F101CGALA

36-PIN PLASTIC FLGA (4x4)



(UNIT:mm)

ITEM	DIMENSIONS
D	4.00±0.10
E	4.00±0.10
w	0.20
e	0.50
A	0.69±0.07
b	0.24±0.05
x	0.05
y	0.08
y1	0.20
ZD	0.75
ZE	0.75

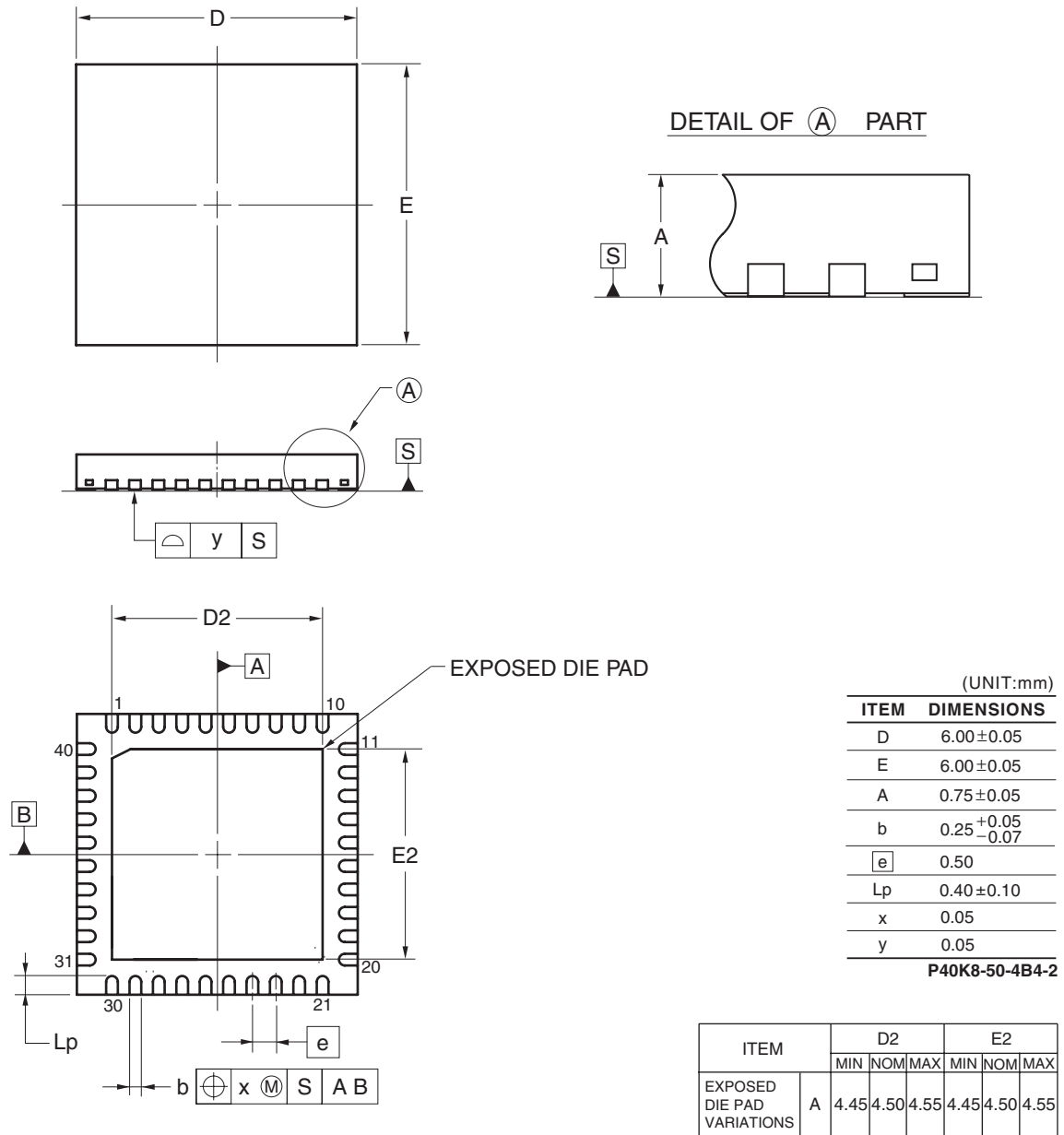
P36FC-50-AA4-1

©2010 Renesas Electronics Corporation. All rights reserved.

30.7 40-pin products

R5F100EAANA, R5F100ECANA, R5F100EDANA, R5F100EEANA, R5F100EFANA, R5F100EGANA, R5F100EHANA  
 R5F101EAANA, R5F101ECANA, R5F101EDANA, R5F101EEANA, R5F101EFANA, R5F101EGANA, R5F101EHANA

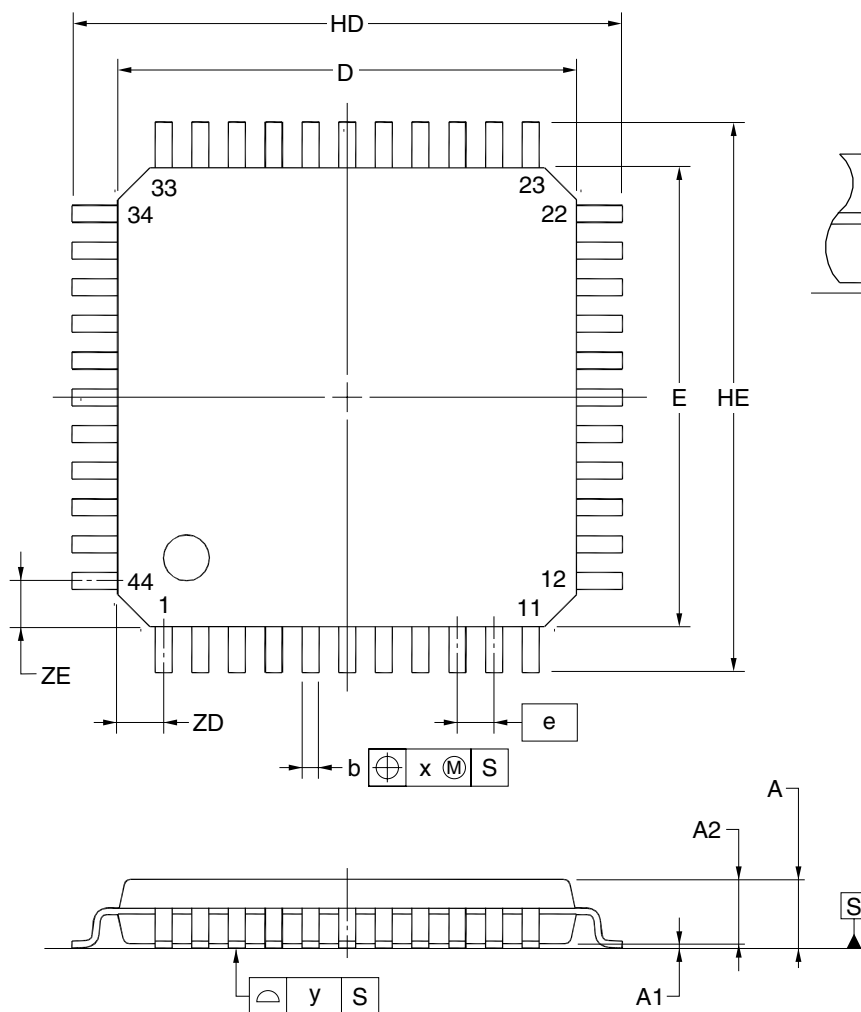
40-PIN PLASTIC WQFN(6x6)



30.8 44-pin products

R5F100FAAFP, R5F100FCAFP, R5F100FDAFP, R5F100FEAFP, R5F100FFAFP, R5F100FGAFP, R5F100FHAFP, R5F100FJAFP, R5F100FKAFP, R5F100FLAFP  
 R5F101FAAFP, R5F101FCAFP, R5F101FDAFP, R5F101FEAFP, R5F101FFAFP, R5F101FGAFP, R5F101FHAFP, R5F101FJAFP, R5F101FKAFP, R5F101FLAFP

44-PIN PLASTIC LQFP(10x10)



(UNIT:mm)

ITEM	DIMENSIONS
D	10.00±0.20
E	10.00±0.20
HD	12.00±0.20
HE	12.00±0.20
A	1.60 MAX.
A1	0.10±0.05
A2	1.40±0.05
A3	0.25
b	0.37 <sup>+0.08</sup> <sub>-0.07</sub>
c	0.145 <sup>+0.055</sup> <sub>-0.045</sub>
L	0.50
Lp	0.60±0.15
L1	1.00±0.20
θ	3° <sup>+5°</sup> <sub>-3°</sub>
e	0.80
x	0.20
y	0.10
ZD	1.00
ZE	1.00

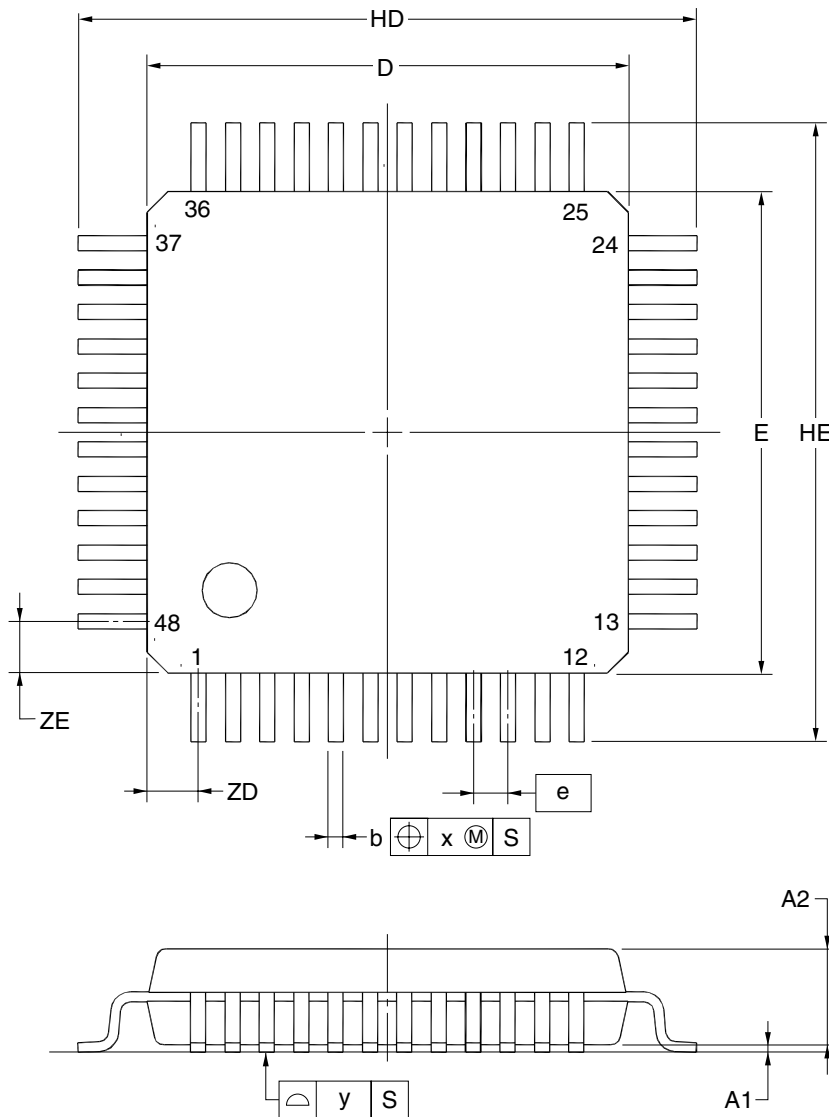
P44GB-80-UES-1

**NOTE**  
 Each lead centerline is located within 0.20 mm of its true position at maximum material condition.

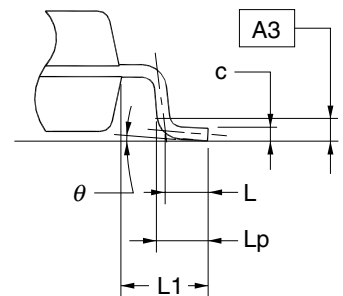
30.9 48-pin products

R5F100GAAFB, R5F100GCAFB, R5F100GDAFB, R5F100GEAFB, R5F100GFAFB, R5F100GGAFB, R5F100GHAFB, R5F100GJAFB, R5F100GKAFB, R5F100GLAFB  
 R5F101GAAFB, R5F101GCAFB, R5F101GDAFB, R5F101GEAFB, R5F101GFAFB, R5F101GGAFB, R5F101GHAFB, R5F101GJAFB, R5F101GKAFB, R5F101GLAFB

48-PIN PLASTIC LQFP (FINE PITCH)(7x7)



detail of lead end



(UNIT:mm)

ITEM	DIMENSIONS
D	7.00±0.20
E	7.00±0.20
HD	9.00±0.20
HE	9.00±0.20
A	1.60 MAX.
A1	0.10±0.05
A2	1.40±0.05
A3	0.25
b	0.22±0.05
c	0.145 <sup>+0.055</sup> <sub>-0.045</sub>
L	0.50
Lp	0.60±0.15
L1	1.00±0.20
θ	3° <sup>+5°</sup> <sub>-3°</sub>
e	0.50
x	0.08
y	0.08
ZD	0.75
ZE	0.75

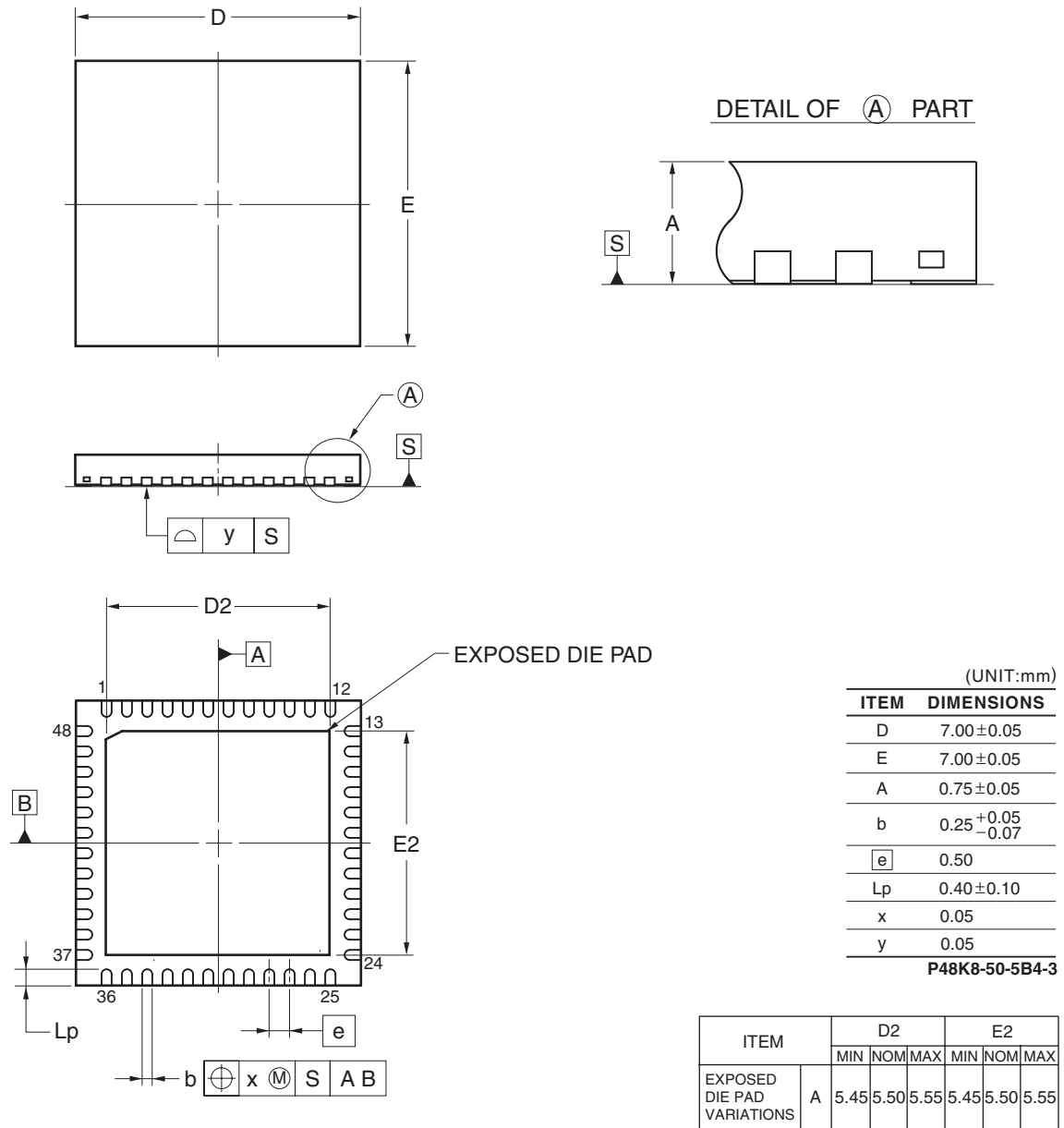
P48GA-50-8EU

NOTE

Each lead centerline is located within 0.08 mm of its true position at maximum material condition.

R5F100GAANA, R5F100GCANA, R5F100GDANA, R5F100GEANA, R5F100GFANA, R5F100GGANA,  
 R5F100GHANA, R5F100GJANA, R5F100GKANA, R5F100GLANA  
 R5F101GAANA, R5F101GCANA, R5F101GDANA, R5F101GEANA, R5F101GFANA, R5F101GGANA,  
 R5F101GHANA, R5F101GJANA, R5F101GKANA, R5F101GLANA

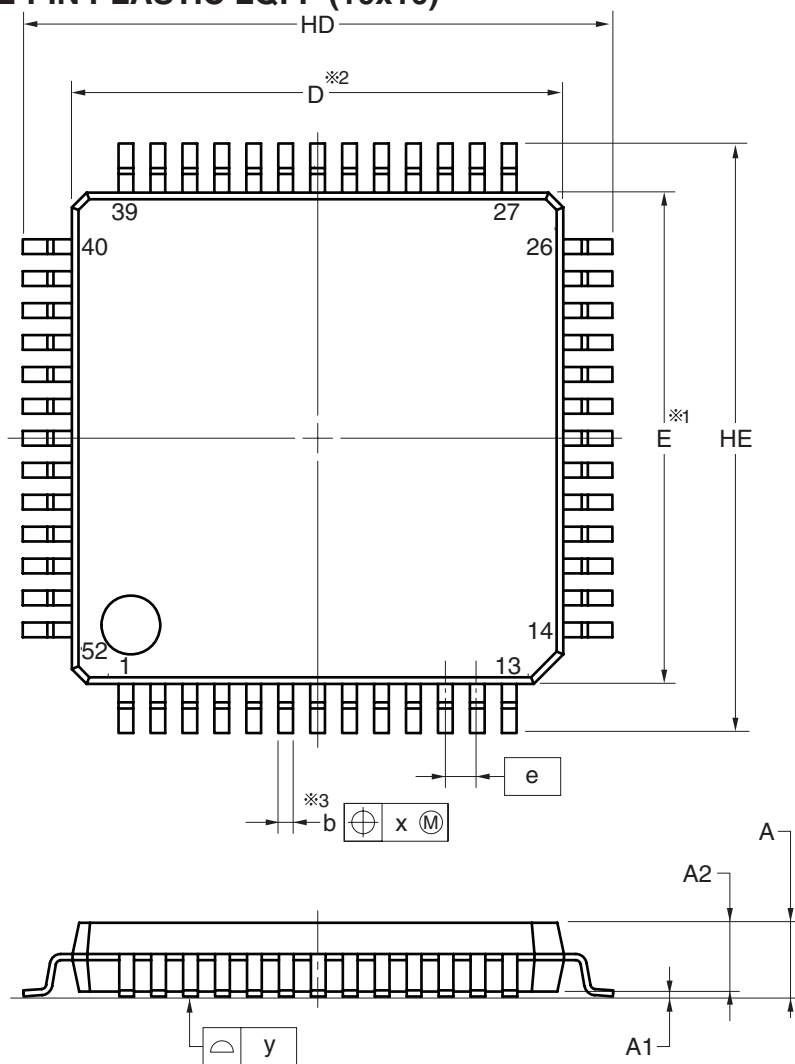
**48-PIN PLASTIC WQFN(7x7)**



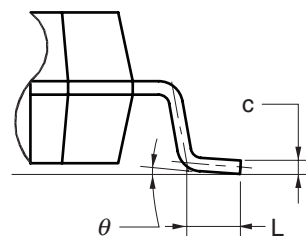
30.10 52-pin products

R5F100JCAFA, R5F100JDAFA, R5F100JEAFA, R5F100JFAFA, R5F100JGAFA, R5F100JHAFA, R5F100JJFAFA,  
 R5F100JKFAFA, R5F100JLAFA  
 R5F101JCAFA, R5F101JDAFA, R5F101JEAFA, R5F101JFAFA, R5F101JGAFA, R5F101JHAFA, R5F101JJFAFA,  
 R5F101JKFAFA, R5F101JLAFA

52-PIN PLASTIC LQFP (10x10)



detail of lead end



(UNIT:mm)

ITEM	DIMENSIONS
D	10.00±0.10
E	10.00±0.10
HD	12.00±0.20
HE	12.00±0.20
A	1.70 MAX.
A1	0.10±0.05
A2	1.40
b	0.32±0.05
c	0.145±0.055
L	0.50±0.15
$\theta$	0° to 8°
e	0.65
x	0.13
y	0.10

P52GB-65-GBS

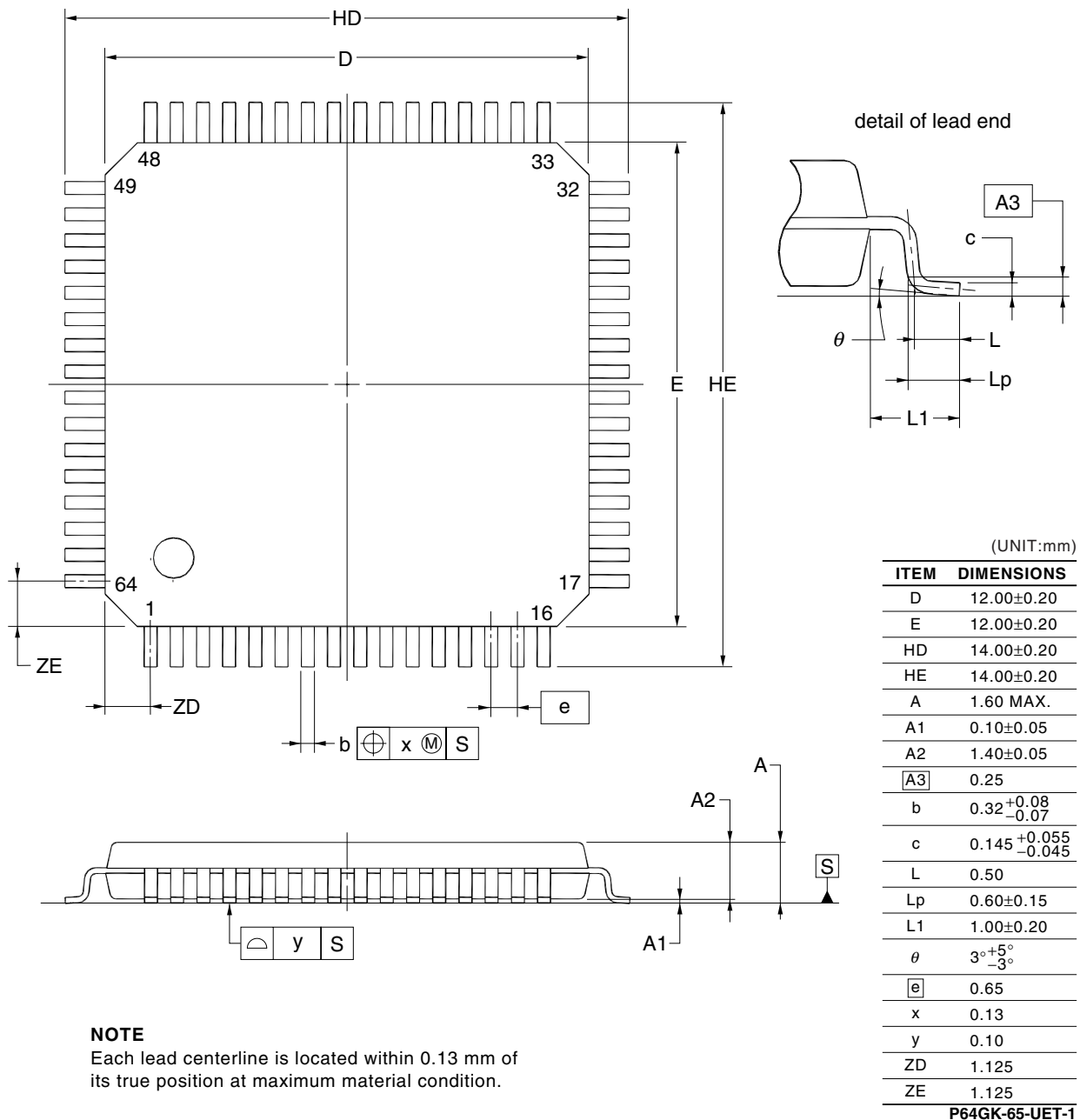
NOTE

1. Dimensions "※1" and "※2" do not include mold flash.
2. Dimension "※3" does not include trim offset.

30.11 64-pin products

R5F100LCAFA, R5F100LDAFA, R5F100LEAFA, R5F100LFAFA, R5F100LGAFA, R5F100LHAFA, R5F100LJAF, R5F100LKAF, R5F100LLAFA  
 R5F101LCAFA, R5F101LDAFA, R5F101LEAFA, R5F101LFAFA, R5F101LGAFA, R5F101LHAFA, R5F101LJAF, R5F101LKAF, R5F101LLAFA

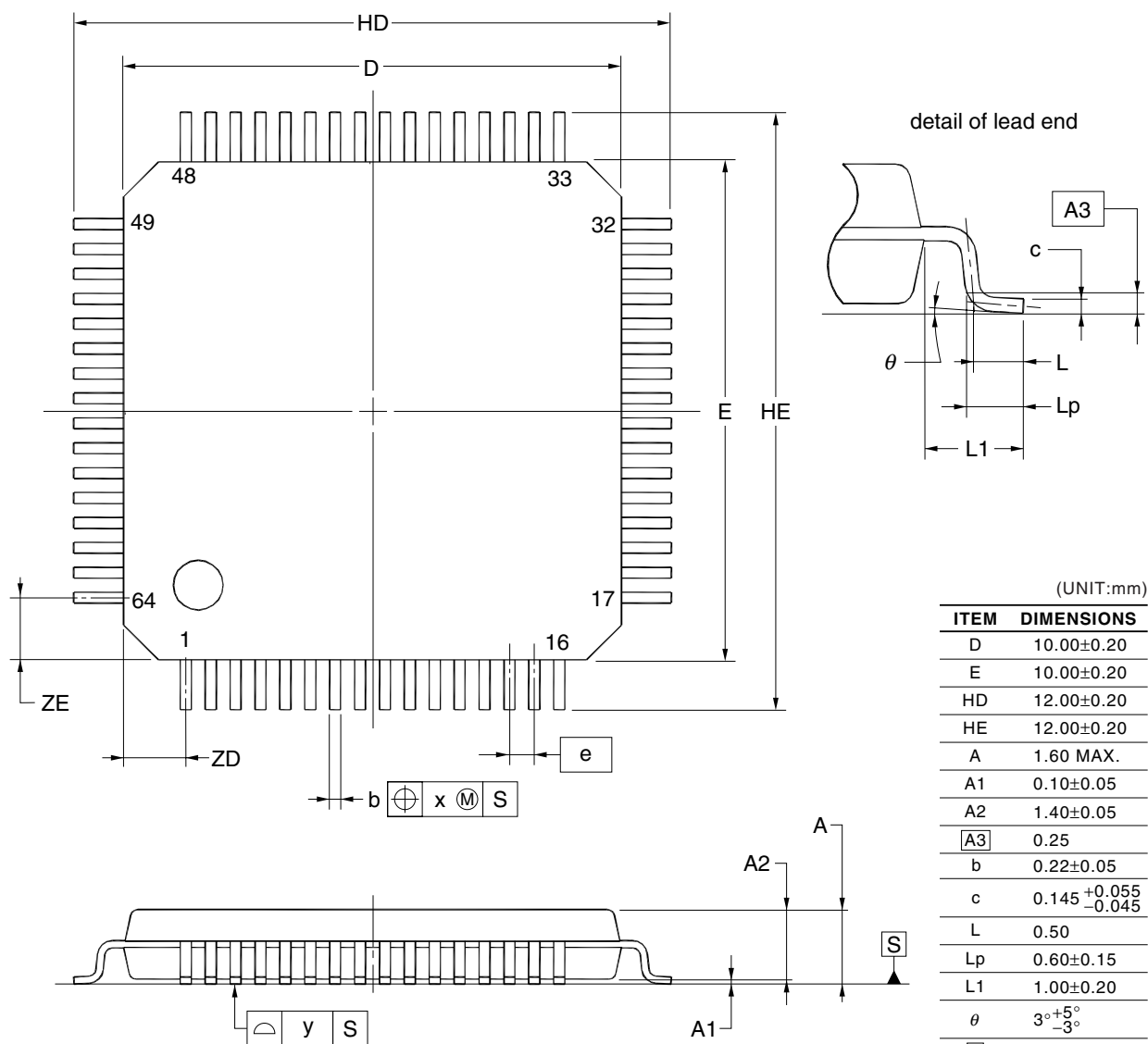
64-PIN PLASTIC LQFP(12x12)





R5F100LCAFB, R5F100LDAFB, R5F100LEAFB, R5F100LFAFB, R5F100LGAFB, R5F100LHAFB, R5F100LJAFB,  
 R5F100LKAFB, R5F100LLAFB  
 R5F101LCAFB, R5F101LDAFB, R5F101LEAFB, R5F101LFAFB, R5F101LGAFB, R5F101LHAFB, R5F101LJAFB,  
 R5F101LKAFB, R5F101LLAFB

**64-PIN PLASTIC LQFP(FINE PITCH)(10x10)**



**NOTE**  
 Each lead centerline is located within 0.08 mm of its true position at maximum material condition.

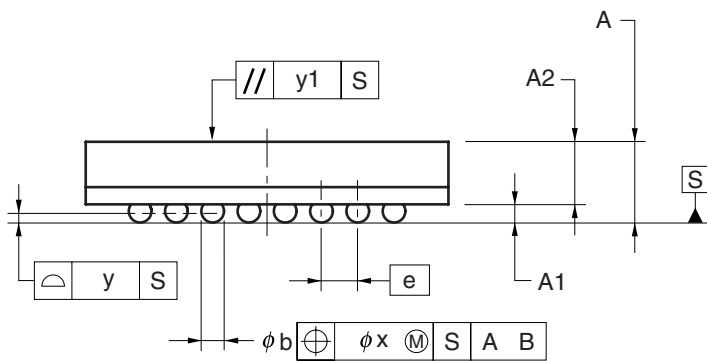
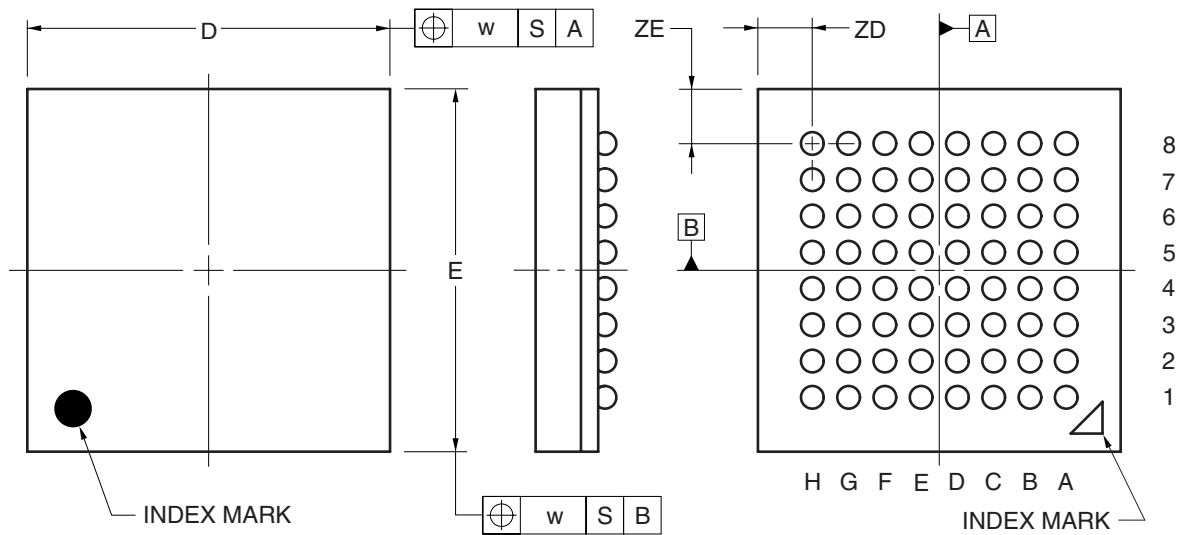
P64GB-50-UEU-1

R5F100LCAFC, R5F100LDAFC, R5F100LEAFC, R5F100LFAFC, R5F100LGAFC, R5F100LHAFC, R5F100LJAF  
R5F101LCAFC, R5F101LDAFC, R5F101LEAFC, R5F101LFAFC, R5F101LGAFC, R5F101LHAFC, R5F101LJAF

64-PIN PLASTIC TQFP (7x7) Under development
--

R5F100LCABG, R5F100LDABG, R5F100LEABG, R5F100LFABG, R5F100LGABG, R5F100LHABG, R5F100LJABG  
 R5F101LCABG, R5F101LDABG, R5F101LEABG, R5F101LFABG, R5F101LGABG, R5F101LHABG, R5F101LJABG

**64-PIN PLASTIC FBGA (4x4)**



(UNIT:mm)

ITEM	DIMENSIONS
D	4.00±0.10
E	4.00±0.10
w	0.15
A	0.89±0.10
A1	0.20±0.05
A2	0.69
e	0.40
b	0.25±0.05
x	0.05
y	0.08
y1	0.20
ZD	0.60
ZE	0.60

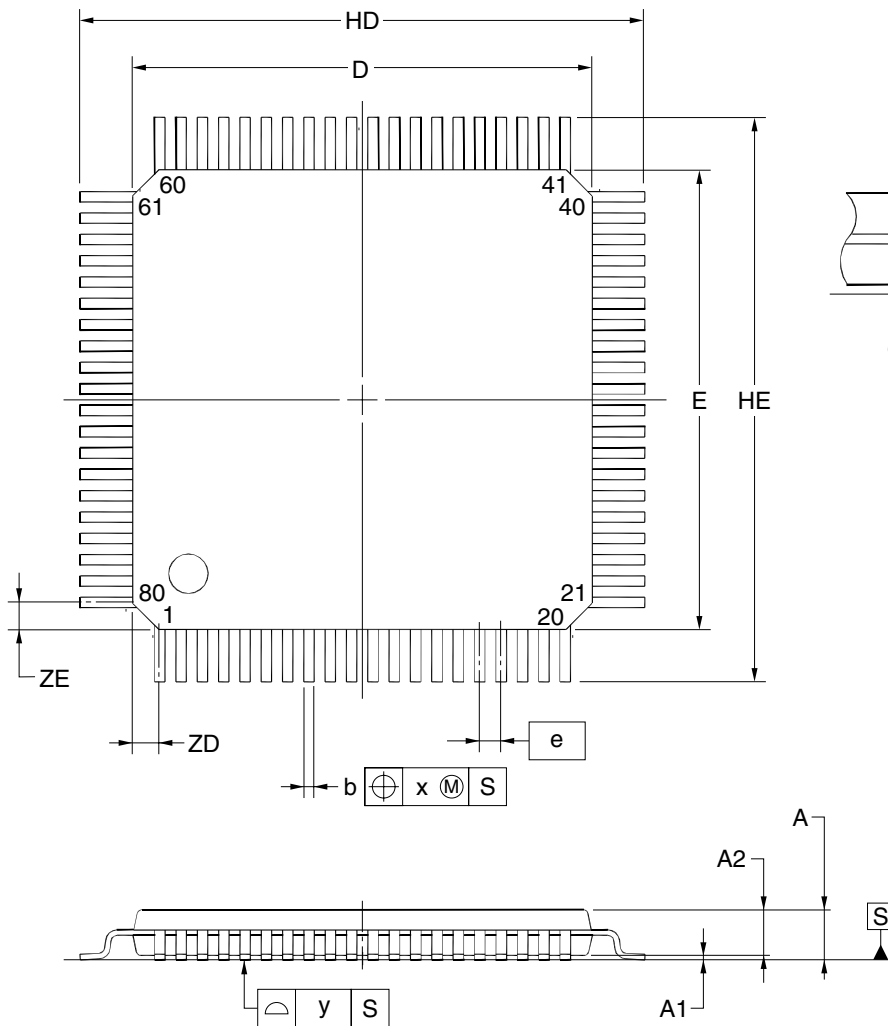
P64F1-40-AA2-1

©2010 Renesas Electronics Corporation. All rights reserved.

30.12 80-pin products

R5F100MFAFA, R5F100MGafa, R5F100MHafa, R5F100MJafa, R5F100MKafa, R5F100MLafa  
 R5F101MFAFA, R5F101MGafa, R5F101MHafa, R5F101MJafa, R5F101MKafa, R5F101MLafa

80-PIN PLASTIC LQFP(14x14)



(UNIT:mm)

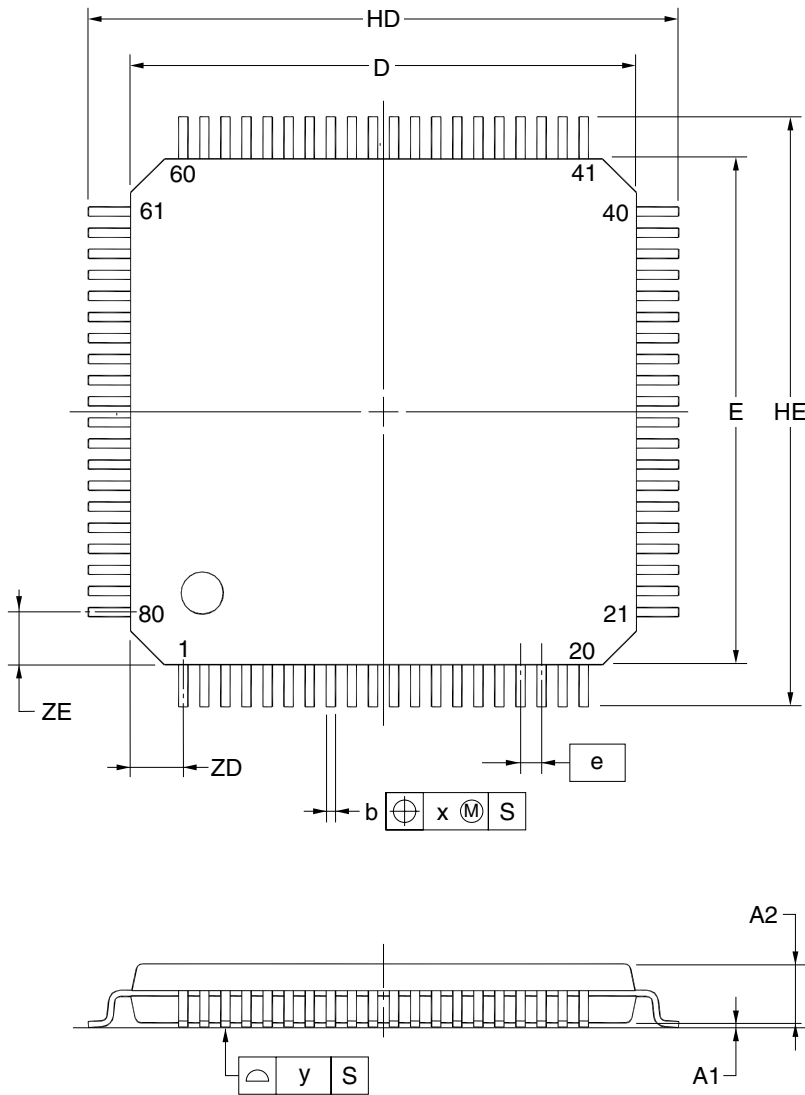
ITEM	DIMENSIONS
D	14.00±0.20
E	14.00±0.20
HD	17.20±0.20
HE	17.20±0.20
A	1.70 MAX.
A1	0.125±0.075
A2	1.40±0.05
A3	0.25
b	0.32±0.06
c	0.17 <sup>+0.03</sup> <sub>-0.06</sub>
L	0.80
Lp	0.886±0.15
L1	1.60±0.20
θ	3° <sup>+5°</sup> <sub>-3°</sub>
e	0.65
x	0.13
y	0.10
ZD	0.825
ZE	0.825
<b>P80GC-65-UBT</b>	

NOTE

Each lead centerline is located within 0.13 mm of its true position at maximum material condition.

R5F100MFAFB, R5F100MGAFB, R5F100MHAFB, R5F100MJAFB, R5F100MKAFB, R5F100MLAFB  
 R5F101MFAFB, R5F101MGAFB, R5F101MHAFB, R5F101MJAFB, R5F101MKAFB, R5F101MLAFB

**80-PIN PLASTIC LQFP(FINE PITCH)(12x12)**



detail of lead end

(UNIT:mm)

ITEM	DIMENSIONS
D	12.00±0.20
E	12.00±0.20
HD	14.00±0.20
HE	14.00±0.20
A	1.60 MAX.
A1	0.10±0.05
A2	1.40±0.05
A3	0.25
b	0.22±0.05
c	0.145 <sup>+0.055</sup> <sub>-0.045</sub>
L	0.50
Lp	0.60±0.15
L1	1.00±0.20
θ	3° <sup>+5°</sup> <sub>-3°</sub>
e	0.50
x	0.08
y	0.08
ZD	1.25
ZE	1.25

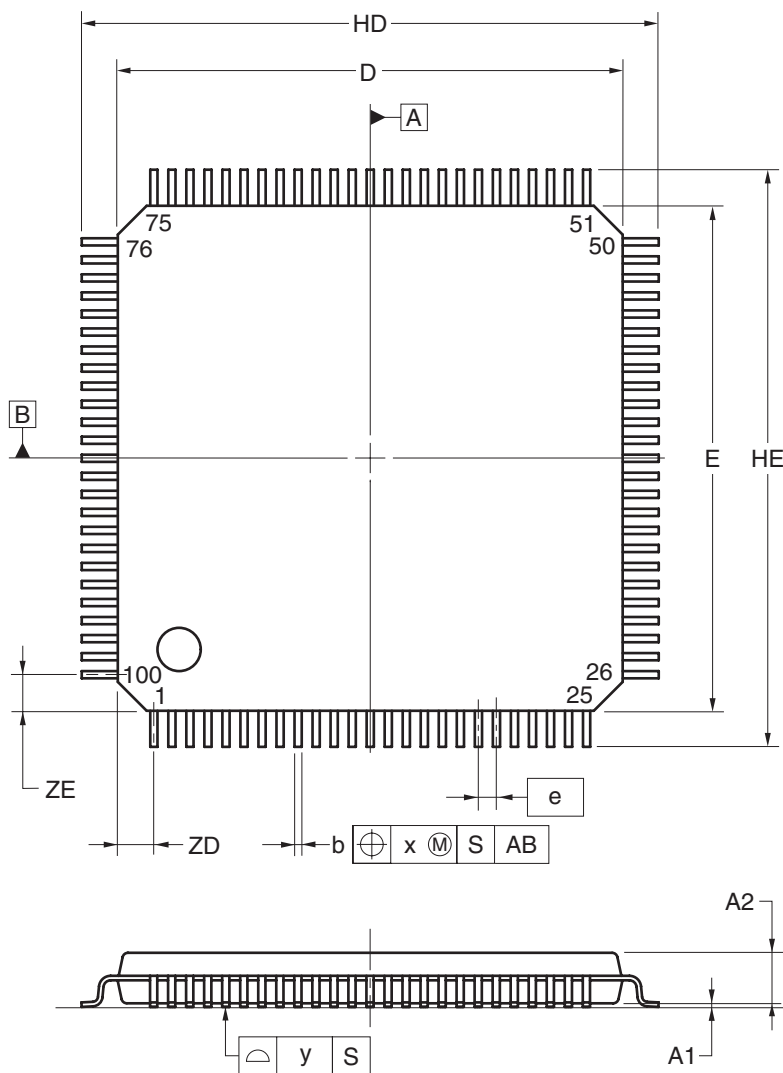
P80GK-50-8EU-1

**NOTE**  
 Each lead centerline is located within 0.08 mm of its true position at maximum material condition.

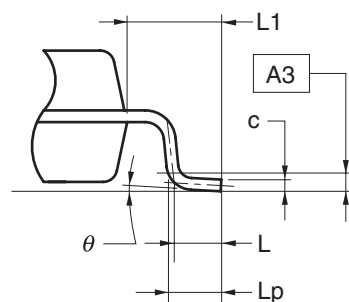
30.13 100-pin products

R5F100PFAFB, R5F100PGAFA, R5F100PHAFA, R5F100PJAFB, R5F100PKAFB, R5F100PLAFB  
 R5F101PFAFB, R5F101PGAFA, R5F101PHAFA, R5F101PJAFB, R5F101PKAFB, R5F101PLAFB

100-PIN PLASTIC LQFP(FINE PITCH) (14x14)



detail of lead end



(UNIT:mm)

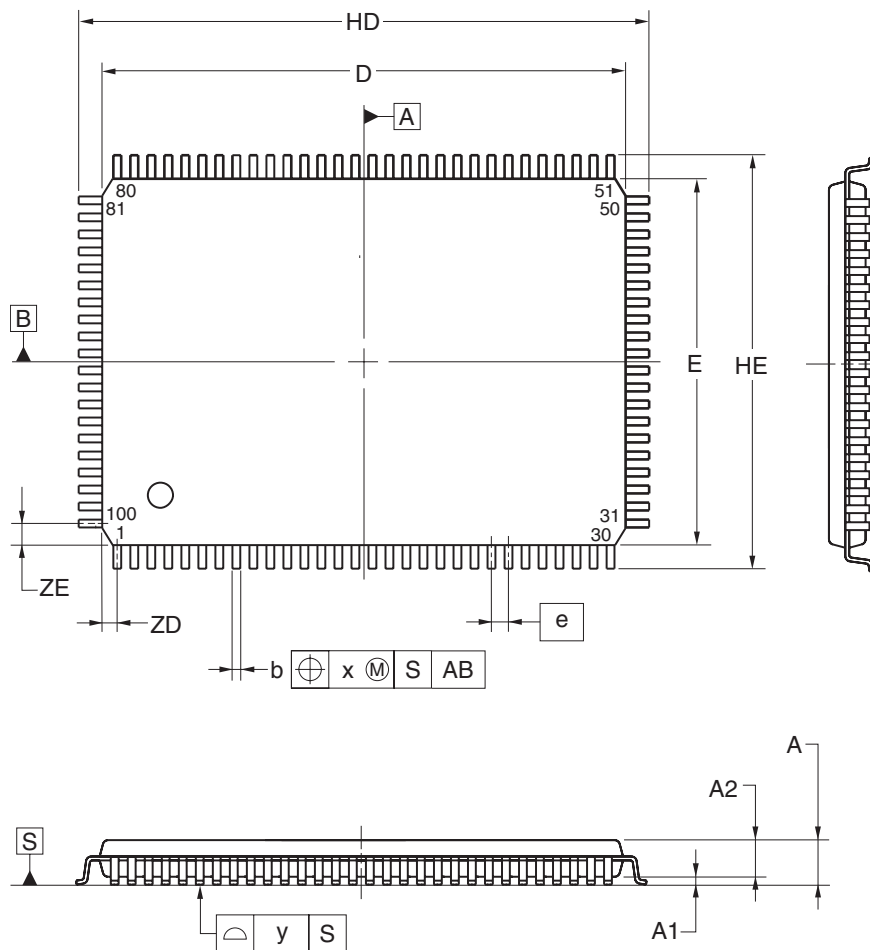
ITEM	DIMENSIONS
D	14.00±0.20
E	14.00±0.20
HD	16.00±0.20
HE	16.00±0.20
A	1.60 MAX.
A1	0.10±0.05
A2	1.40±0.05
A3	0.25
b	0.22±0.05
c	0.145 <sup>+0.055</sup> <sub>-0.045</sub>
L	0.50
Lp	0.60±0.15
L1	1.00±0.20
θ	3° <sup>+5°</sup> <sub>-3°</sub>
e	0.50
x	0.08
y	0.08
ZD	1.00
ZE	1.00

P100GC-50-GBR

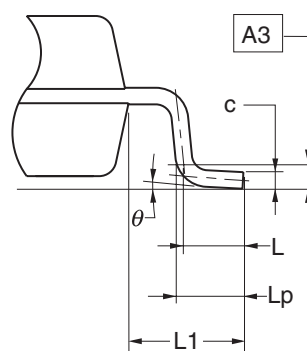
© 2011 Renesas Electronics Corporation. All rights reserved.

R5F100PFAFA, R5F100PGAFA, R5F100PHAFA, R5F100PJAJA, R5F100PKAFA, R5F100PLAFA  
 R5F101PFAFA, R5F101PGAFA, R5F101PHAFA, R5F101PJAJA, R5F101PKAFA, R5F101PLAFA

**100-PIN PLASTIC LQFP (14x20)**



detail of lead end



(UNIT:mm)

ITEM	DIMENSIONS
D	20.00±0.20
E	14.00±0.20
HD	22.00±0.20
HE	16.00±0.20
A	1.60 MAX.
A1	0.10±0.05
A2	1.40±0.05
A3	0.25
b	0.32 <sup>+0.08</sup> <sub>-0.07</sub>
c	0.145 <sup>+0.055</sup> <sub>-0.045</sub>
L	0.50
Lp	0.60±0.15
L1	1.00±0.20
θ	3° <sup>+5°</sup> <sub>-3°</sub>
e	0.65
x	0.13
y	0.10
ZD	0.575
ZE	0.825

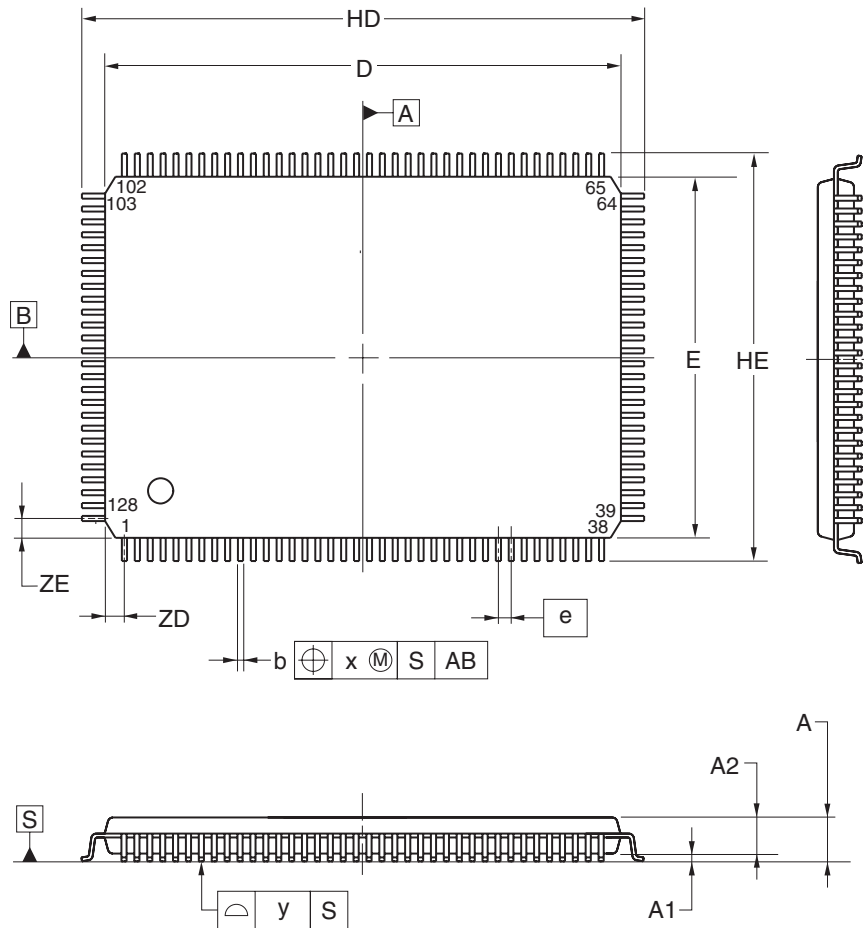
P100GF-65-GBN

© 2011 Renesas Electronics Corporation. All rights reserved.

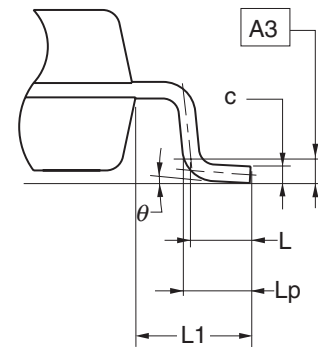
30.14 128-pin products

R5F100SHAFB, R5F100SJAFB, R5F100SKAFB, R5F100SLAFB  
 R5F101SHAFB, R5F101SJAFB, R5F101SKAFB, R5F101SLAFB

128-PIN PLASTIC LQFP(FINE PITCH) (14x20)



detail of lead end



(UNIT:mm)

ITEM	DIMENSIONS
D	20.00±0.20
E	14.00±0.20
HD	22.00±0.20
HE	16.00±0.20
A	1.60 MAX.
A1	0.10±0.05
A2	1.40±0.05
A3	0.25
b	0.22±0.05
c	0.145 <sup>+0.055</sup> <sub>-0.045</sub>
L	0.50
Lp	0.60±0.15
L1	1.00±0.20
θ	3° <sup>+5°</sup> <sub>-3°</sub>
e	0.50
x	0.08
y	0.08
ZD	0.75
ZE	0.75

P128GF-50-GBP

© 2011 Renesas Electronics Corporation. All rights reserved.



## APPENDIX A REVISION HISTORY

## A.1 Major Revisions in This Edition

(1/7)

Page	Description	Classification
<b>R01UH0146EJ0007 → R01UH0146EJ0100</b>		
-	Change the internal high-speed oscillator to high-speed on-chip oscillator	(c)
-	Change the internal low-speed oscillator to low-speed on-chip oscillator	(c)
-	Deletion of target in ELECTRICAL SPECIFICATIONS	(b)
<b>CHAPTER 1 OUTLINE</b>		
Though out	Expose the function for peripheral I/O redirection register (PIOR)	(b)
p. 2	Change of note 1 to note 3	(c)
p. 40, 42	Change of note 1	(c)
<b>CHAPTER 2 PIN FUNCTIONS</b>		
Though out	Expose the function for peripheral I/O redirection register (PIOR)	(b)
p. 75, 78	Change of <b>2.1.15 Pins for each product (pins other than port pins)</b>	(a), (b)
p. 80, 82, 90	Addition of description for digital I/O/analog input to <b>2.2 Description of Pin Functions</b>	(c)
p. 87, 88	Change of description for pull-up resistor option register in <b>2.2 Description of Pin Functions</b>	(c)
p. 91	Addition of remark to <b>2.2.17 (2) V<sub>ss</sub>, EV<sub>sso</sub>, EV<sub>ss1</sub></b> Change of description in <b>2.2.19 REGC</b>	(c), (b)
p. 93	Addition of remark 3 to <b>Table 2-3. Connection of Unused Pins (128-pin products) (2/4)</b>	(c)
p. 96, 97	Change of <b>Figure 2-1. Pin I/O Circuit List</b>	(a)
<b>CHAPTER 3 CPU ARCHITECTURE</b>		
p. 99 to 101	Change of <b>Figure 3-1 to Figure 3-3</b>	(c)
p. 101, 102, 106, 108	Change of note 1 in <b>Figure 3-3, Figure 3-4, Figure 3-8, Figure 3-10</b>	(c)
p. 115	Change of <b>Table 3-3. Vector Table</b>	(a)
p. 117	Change of description in <b>3.1.2 Mirror area</b>	(c)
p. 119	Change of caution 2 in <b>3.1.3 Internal data memory space</b>	(c)
p. 121 to 123	Change of <b>Figure 3-12 to Figure 3-14</b>	(c)
p. 123, 124, 128, 130	Change of note 1 in <b>Figure 3-14, Figure 3-15, Figure 3-19, Figure 3-21</b>	(c)
p. 132	Change of caution 3 in <b>3.2.1 (3) Stack pointer (SP)</b>	(c)
p. 133	Change of caution 2 in <b>3.2.2 General-purpose registers</b>	(c)
p. 144	Change and addition of note in <b>Table 3-6. Extended SFR (2nd SFR) List (2/8)</b>	(a), (c)
p. 149	Change of <b>Table 3-6. Extended SFR (2nd SFR) List (7/8)</b>	(c)
p. 152	Change of <b>Figure 3-31. Outline of Table Indirect Addressing</b>	(c)

**Remark** "Classification" in the above table classifies revisions as follows.

- (a): Error correction, (b): Addition/change of specifications, (c): Addition/change of description or note, (d): Addition/change of package, part number, or management division, (e): Addition/change of related documents

(2/7)

Page	Description	Classification
<b>CHAPTER 4 PORT FUNCTIONS</b>		
Though out	Addition of <b>Table 4-x. Settings of Registers When Using Port x</b>	(c)
Though out	Change of <b>Block Diagram</b> in <b>4.2 Port Configuration</b> to be corresponded to 128-pin products	(c)
Though out	Change of description for Digital I/O/analog input in <b>4.2 Port Configuration</b>	(c)
Though out	Change of description for reset signal generation in <b>4.2 Port Configuration</b>	(c)
p. 180	Change of <b>Figure 4-10. Block Diagram of P13</b>	(c)
p. 186	Change of <b>Figure 4-15. Block Diagram of P20 to P27</b>	(c)
p. 197	Change of <b>Figure 4-23. Block Diagram of P43, P44</b>	(a)
p. 199	Change of <b>Figure 4-25. Block Diagram of P46</b>	(a)
p. 200	Change of <b>Figure 4-26. Block Diagram of P47</b>	(a)
p. 236	Change of <b>Figure 4-52. Block Diagram of P121 and P122</b>	(c)
p. 237	Change of <b>Figure 4-53. Block Diagram of P123 and P124</b>	(c)
p. 239	Change of description in <b>4.2.14 Port 13</b>	(c)
p. 250	Change of <b>Figure 4-64. Block Diagram of P150 to P156</b>	(c)
p. 251, 252	Change of <b>Table 4-21. PMxx, Pxx, PUxx, PIMxx, POMxx, PMCxx registers and the bits mounted on each product (20-pin products to 64-pin products)</b>	(c)
p. 256	Change of <b>Table 4-22. PMxx, Pxx, PUxx, PIMxx, POMxx, PMCxx registers and the bits mounted on each product (80-pin products to 128-pin products) (3/4)</b>	(c)
p. 265	Change of <b>Figure 4-70. Format of Port Mode Control Register</b>	(c)
p. 268	Change of cautions 1 and 2 in <b>Figure 4-72. Format of Peripheral I/O Redirection Register (PIOR)</b>	(c)
p. 269	Change of description in <b>4.3 (9) Global digital input disable register (GDIDIS)</b>	(c)
p. 271, 272	Change of description in <b>4.4.4 Connecting to external device with different potential (1.8 V, 2.5 V, 3 V)</b>	(c)
p. 273 to 277	Change of <b>Table 4-23. Settings of Port Mode Register, and Output Latch When Using Alternate Function</b>	(b), (c)
p. 278	Addition of note 3 to <b>Table 4-23. Settings of Port Mode Register, and Output Latch When Using Alternate Function</b>	(c)
p. 279	Addition of <b>4.6 Cautions When Using Port Function</b>	(c)
p. 280, 281	Addition of <b>4.6.2 Cautions on the pin settings on the products other than 128-pin</b>	(c)
<b>CHAPTER 5 CLOCK GENERATOR</b>		
p. 283	Change of description in <b>5.1 (2) Subsystem clock</b>	(c)
p. 285	Change of <b>Figure 5-1. Block Diagram of Clock Generator</b>	(c)
p. 287	Change and addition of note to <b>Figure 5-2. Format of Clock Operation Mode Control Register (CMC)</b>	(c)
p. 289	Change of description and deletion of note 2 in <b>5.3 (2) System clock control register (CKC)</b>	(c)
p. 295	Change of <b>Figure 5-6. Format of Oscillation Stabilization Time Select Register (OSTS)</b>	(c)
p. 296	Deletion of note 4 in <b>Figure 5-7. Format of Peripheral Enable Register 0 (PER0)</b>	(c)
p. 299	Change of description and deletion of caution in <b>5.3 (7) Operation speed mode control register (OSMC)</b>	(c)
p. 300	Change of cautions 2, 3 in <b>Figure 5-9. Format of High-speed On-chip Oscillator Frequency Select Register (HOCODIV)</b>	(c)
p. 301	Change of <b>5.3 (9) High-speed on-chip oscillator trimming register (HIOTRM)</b>	(c)
p. 308	Addition of note 3 to <b>Figure 5-14. Clock Generator Operation When Power Supply Voltage Is Turned On</b>	(c)
p. 309	Change of <b>5.6.1 Example of setting high-speed on-chip oscillator</b>	(c)
p. 310	Change of description in <b>5.6.2 Example of setting X1 oscillation clock</b>	(c)
p. 315	Change of (6) and (8) in <b>Table 5-3. CPU Clock Transition and SFR Register Setting Examples</b>	(c)
p. 320	Change of <b>Table 5-6 and Table 5-7</b>	(c)

**Remark** "Classification" in the above table classifies revisions as follows.

- (a): Error correction, (b): Addition/change of specifications, (c): Addition/change of description or note,
- (d): Addition/change of package, part number, or management division, (e): Addition/change of related documents

(3/7)

Page	Description	Classification
<b>CHAPTER 6 TIMER ARRAY UNIT</b>		
p. 329	Change of <b>Table 6-2. Timer I/O Pins provided in Each Product</b>	(c)
p. 332	Change of <b>6.2 (1) Timer count register mn (TCRmn)</b>	(c)
p. 336	Change of caution in <b>6.3 (2) Timer clock select register m (TPSm)</b>	(c)
p. 338	Addition of note to <b>Table 6-4. Interval Times Available for Operation Clock CKSm2 or CKSm3</b>	(c)
p. 339	Change of caution in <b>6.3 (3) Timer mode register mn (TMRmn)</b>	(c)
p. 340 to 343	Change of <b>Figure 6-8. Format of Timer Mode Register mn (TMRmn)</b>	(c)
p. 345	Change of description in <b>6.3 (5) Timer channel enable status register m (TEm)</b>	(c)
p. 346	Change of description in <b>6.3 (6) Timer channel start register m (TSM)</b>	(c)
p. 353	Change of <b>Figure 6-18. Format of Input Switch Control Register (ISC)</b>	(c)
p. 357	Addition of remark to <b>6.3 (15) Port mode registers 0, 1, 3, 4, 6, 10, 14 (PM0, PM1, PM3, PM4, PM6, PM10, PM14)</b>	(c)
p. 359	Change of description in <b>6.4.1 Basic rules of simultaneous channel operation function</b>	(c)
p. 369	Change of description in <b>6.5.2 (e) Start timing in capture &amp; one-count mode (when high-level width is measured)</b> Change of <b>Figure 6-27. Start Timing (In Capture &amp; One-count Mode)</b>	(c)
p. 373	Change of <b>Figure 6-30. TOMn Pin Output Status at Toggle Output (TOMmn = 0)</b>	(c)
p. 381, 382, 388, 397, 401, 403, 405, 412, 419, 427	Change of note in <b>Figure 6-37, Figure 6-39, Figure 6-43, Figure 6-51, Figure 6-55, Figure 6-57, Figure 6-59, Figure 6-64, Figure 6-69, Figure 6-74</b>	(c)
p. 382, 388, 397, 401, 405	Change of operation clock ( $f_{MCK}$ ) selection in <b>Figure 6-39, Figure 6-43, Figure 6-51, Figure 6-55, Figure 6-59</b>	(c)
p. 395, 400	Addition of note to <b>Figure 6-49, Figure 6-53</b>	(c)
p. 403	Change of description in <b>6.7.6 Operation as delay counter</b>	(c)
p. 430	Addition of <b>6.9 Cautions When Using Timer Array Unit</b>	(c)
<b>CHAPTER 7 REAL-TIME CLOCK</b>		
p. 431	Change of caution in <b>7.1 Functions of Real-time Clock</b>	(c)
p. 432	Change of figure and caution in <b>Figure 7-1. Block Diagram of Real-time Clock</b>	(c)
p. 434	Deletion of caution 4 of <b>7.3 (1) Peripheral enable register 0 (PER0)</b>	(c)
p. 435	Change of caution in <b>7.3 (2) Operation speed mode control register (OSMC)</b>	(c)
p. 438	Change of <b>Figure 7-5. Format of Real-time Clock Control Register 1 (RTCC1) (2/2)</b>	(c)
p. 439, 440, 442 to 444	Change of description and caution in <b>7.3 (5) Second count register (SEC) to 7.3 (11) Year count register (YEAR)</b>	(c)
p. 450	Change of description in <b>7.4.3 Reading/writing real-time clock</b>	(c)
p. 451	Addition of caution 2 to <b>Figure 7-20. Procedure for Writing Real-time Clock</b>	(c)
p. 453	Change of <b>Figure 7-22. 1 Hz Output Setting Procedure</b>	(c)
<b>CHAPTER 8 INTERVAL TIMER</b>		
p. 457	Change of description in <b>8.1 Functions of Interval Timer</b>	(c)
p. 460	Change of caution 1 in <b>Figure 8-4. Format of Interval Timer Control Register (ITMC)</b>	(c)

**Remark** "Classification" in the above table classifies revisions as follows.

- (a): Error correction, (b): Addition/change of specifications, (c): Addition/change of description or note, (d): Addition/change of package, part number, or management division, (e): Addition/change of related documents

(4/7)

Page	Description	Classification
<b>CHAPTER 9 CLOCK OUTPUT/BUZZER OUTPUT CONTROLLER</b>		
p. 463	Change of note and addition of remark to <b>Figure 9-1. Block Diagram of Clock Output/Buzzer Output Controller</b>	(a), (c)
p. 465	Change of <b>Figure 9-2. Format of Clock Output Select Register n (CKSn)</b>	(c)
p. 466	Change of <b>9.3 (2) Port mode register 1, 3, 5, 14 (PM1, PM3, PM5, PM14)</b>	(c)
<b>CHAPTER 10 WATCHDOG TIMER</b>		
p. 472	Change of caution 4 and deletion of caution 5 in <b>10.4.1 Controlling operation of watchdog timer</b> Deletion of caution of <b>Table 10-3. Setting of Overflow Time of Watchdog Timer</b>	(c)
p. 473, 474	Deletion of caution 1 and change of remark in <b>Table 10-4. Setting Window Open Period of Watchdog Timer</b>	(c)
<b>CHAPTER 11 A/D CONVERTER</b>		
p. 475	Change of description in <b>11.1 Function of A/D Converter</b>	(c)
p. 476	Change of <b>Figure 11-1. Block Diagram of A/D Converter</b>	(c)
p. 477, 478	Change of description in <b>11.2 Configuration of A/D Converter</b>	(b), (c)
p. 479	Change of <b>11.3 Registers Used in A/D Converter</b>	(c)
p. 482	Addition of note to <b>Table 11-1. Settings of ADCS and ADCE Bits</b> Change of <b>Table 11-2. Setting and Clearing Conditions for ADCS Bit</b>	(c)
p. 486, 487, 490, 491	Change of <b>Table 11-3. A/D Conversion Time Selection</b>	(c)
p. 493	Change of <b>Figure 11-7. Format of A/D Converter Mode Register 2 (ADM2)</b>	(a), (c)
p. 494	Change of <b>Figure 11-8. ADRCK Bit Interrupt Signal Generation Range</b>	(a)
p. 496, 497	Change of <b>Figure 11-11. Format of Analog Input Channel Specification Register (ADS)</b>	(c)
p. 499	Change of <b>Figure 11-14. Format of A/D Test Register (ADTES)</b>	(c)
p. 500	Change of description in <b>11.3 (11) A/D port configuration register (ADPC)</b>	(c)
p. 501	Change of <b>11.3 (12) Port mode control registers 0, 3, 10, 11, 12, 14 (PMC0, PMC3, PMC10, PMC11, PMC12, PMC14)</b>	(c)
p. 502, 503	Change of <b>11.3 (13) Port mode register 0, 2, 3, 10, 11, 12, 14, 15 (PM0, PM2, PM3, PM10, PM11, PM12, PM14, PM15)</b>	(c)
p. 507 to 518	Change from "power down status" to "stop status" in <b>11.6 A/D Converter Operation Modes</b>	(c)
p. 523	Change of <b>11.7.4 Setup when using temperature sensor (example for software trigger mode and one-shot conversion mode)</b>	(c)
p. 526	Addition of description to <b>11.8 (1) If an interrupt is generated after A/D conversion ends</b>	(c)
p. 530	Change of <b>11.10 (2) Input range of ANI0 to ANI14 and ANI16 to ANI26 pins</b>	(b)
p. 533	Change of <b>Table 11-6. Resistance and Capacitance Values of Equivalent Circuit (Reference Values)</b>	(b)

**Remark** "Classification" in the above table classifies revisions as follows.

- (a): Error correction, (b): Addition/change of specifications, (c): Addition/change of description or note, (d): Addition/change of package, part number, or management division, (e): Addition/change of related documents

(5/7)

Page	Description	Classification
<b>CHAPTER 12 SERIAL ARRAY UNIT</b>		
Though out	Addition of description of CSI30, CSI31, UART3, IIC30, IIC31 (corresponding to 128-pin products)	(c)
Though out	Change of description to be corresponded to 128-pin products	(c)
p. 536, 537, 574, 631 to 634, 638, 658 to 662	Change of description to CSI-UART channel corresponding SNOOZE mode	(c)
p. 543, 638, 641, 642, 651	Change of description to UART channel corresponding 9-bit data communication	(c)
p. 535	Change of caution in <b>CHAPTER 12 SERIAL ARRAY UNIT</b>	(c)
p. 538	Change of description in <b>12.1.3 Simplified I<sup>2</sup>C (IIC00, IIC01, IIC10, IIC11, IIC20, IIC21, IIC30, IIC31)</b>	(c)
p. 540	Change of note 1 in <b>Table 12-1. Configuration of Serial Array Unit</b>	(c)
p. 542	Change of <b>Figure 12-2. Block Diagram of Serial Array Unit 1</b>	(c)
p. 544	Addition of note to <b>Figure 12-3 and 12-4</b>	(c)
p. 546	Change of caution 1 in <b>Figure 12-5. Format of Peripheral Enable Register 0 (PER0)</b>	(c)
p. 548	Change of <b>Figure 12-6. Format of Serial Clock Select Register m (SPSm)</b>	(c)
p. 551, 552	Change of note 2 and caution in <b>Figure 12-8. Format of Serial Communication Operation Setting Register mn (SCRmn)</b>	(c)
p. 553	Change of description in <b>12.3 (5) Higher 7 bits of the serial data register mn (SDRmn)</b>	(c)
p. 558	Addition of caution 2 to <b>Figure 12-12. Format of Serial Channel Start Register m (SSm)</b>	(c)
p. 563	Change of description in <b>12.3 (13) Serial output level register m (SOLm)</b>	(c)
p. 564	Change of note and addition of caution to <b>12.3 (14) Serial standby control register m (SSCm)</b>	(c)
p. 565	Change of <b>Figure 12-19. Format of Input Switch Control Register (ISC)</b>	(c)
p. 584, 586, 593, 595, 602, 604, 611, 613, 620, 628, 630, 632, 634	Change of flowchart for each operation mode	(c)
p. 654	Change of <b>Figure 12-86. Initial Setting Procedure for UART Reception</b>	(c)
p. 655	Change of <b>Figure 12-88. Procedure for Resuming UART Reception</b>	(c)
p.680, 686, 690	Change of note in <b>12.8.1 Address field transmission to 12.8.3 Data reception</b>	(c)
<b>CHAPTER 13 SERIAL INTERFACE IICA</b>		
p. 709, 710	Change of <b>Figure 13-6. Format of IICA Control Register 00 (IICCTL00)</b>	(c)
p. 713	Change of <b>Figure 13-7. Format of IICA Status Register 0 (IICSO)</b>	(c)
p. 720	Change of <b>13.4.2 Setting transfer clock by using IICWL0 and IICWH0 registers</b>	(c)
p. 779	Change of description in <b>Figure 13-33. Example of Slave to Master Communication (8-Clock Wait Is Selected for Master, 9-Clock Wait Is Selected for Slave) (1/3)</b>	(c)
<b>CHAPTER 14 MULTIPLIER AND DIVIDER/MULTIPLY-ACCUMULATOR</b>		
p. 792	Change of <b>Figure 14-6. Timing Diagram of Multiplication (Unsigned) Operation (2 × 3 = 6)</b>	(c)
p. 794	Change of description in <b>14.4.3 Multiply-accumulation (unsigned) operation</b>	(c)
p. 795	Change of <b>Figure 14-8. Timing Diagram of Multiply-Accumulation (Unsigned) Operation (2 × 3 + 3 = 9 → 32767 × 2 + 4294901762 = 0 (over flow generated))</b>	(c)
p. 796	Change of description in <b>14.4.4 Multiply-accumulation (signed) operation</b>	(c)
p. 797	Change of <b>Figure 14-9. Timing Diagram of Multiply-Accumulation (signed) Operation (2 × 3 + (- 4) = 2 → 32767 × (- 1) + (- 2147483647) = - 2147450882 (overflow occurs.))</b>	(c)

**Remark** "Classification" in the above table classifies revisions as follows.

- (a): Error correction, (b): Addition/change of specifications, (c): Addition/change of description or note, (d): Addition/change of package, part number, or management division, (e): Addition/change of related documents

(6/7)

Page	Description	Classification
<b>CHAPTER 15 DMA CONTROLLER</b>		
p. 802	Change of <b>Table 15-2 Internal RAM Area other than the General-purpose Registers</b>	(c)
p. 821	Change of (4) and addition of (6) to <b>15.6 Cautions on Using DMA Controller</b>	(c)
<b>CHAPTER 16 INTERRUPT FUNCTION</b>		
p. 823, 825, 826	Change of <b>Table 16-1. Interrupt Source List</b>	(c)
p. 830	Change of <b>Table 16-2. Flags Corresponding to Interrupt Request Sources</b>	(c)
p. 845	Change of caution in <b>16.4.2 Software interrupt request acknowledgment</b>	(c)
<b>CHAPTER 18 STANDBY FUNCTION</b>		
p. 853	Change of cautions 2, 4 and remark, and addition of caution 3 to <b>18.1.1 Standby function</b>	(c)
p. 860, 861	Addition of note to <b>Figure 18-3</b> and <b>Figure 18-4</b> .	(c)
p. 862	Change of remark in <b>18.2.2 (1) STOP mode setting and operating statuses</b>	(c)
p. 863, 864	Change of remark 2, caution 2 in <b>Table 18-2. Operating Statuses in STOP Mode</b>	(c)
p. 864 to 866	Addition of note to <b>Figure 18-5</b> and <b>Figure 18-6</b> .	(c)
p. 867	Change of remark in <b>18.2.3 (1) SNOOZE mode setting and operating statuses</b>	(c)
p. 868	Change of remark 2 in <b>Table 18-3. Operating Statuses in SNOOZE Mode</b>	(c)
<b>CHAPTER 19 RESET FUNCTION</b>		
p. 869	Change of description and deletion caution 3 in <b>CHAPTER 19 RESET FUNCTION</b>	(c)
p. 871, 872	Change of <b>Figure 19-2.</b> to <b>Figure 19-4</b> .	(c)
p. 874	Change of <b>Table 19-2. Hardware Statuses After Reset Acknowledgment (1/4)</b> and change of note 2	(c)
p. 878	Change of values of LVIM, LVIS of note 2 in <b>Table 19-2. Hardware Statuses After Reset Acknowledgment (4/4)</b>	(c)
<b>CHAPTER 20 POWER-ON-RESET CIRCUIT</b>		
p. 883	Change of figure and addition of note 4 to <b>Figure 20-2. Timing of Generation of Internal Reset Signal by Power-on-reset Circuit and Voltage Detector (1/2)</b>	(b), (c)
p. 884	Change of note 4 and addition of note 5 to <b>Figure 20-2. Timing of Generation of Internal Reset Signal by Power-on-reset Circuit and Voltage Detector (2/2)</b>	(b)
p. 885	Change of <b>Figure 20-3. Example of Software Processing After Reset Release</b>	(c)
<b>CHAPTER 21 VOLTAGE DETECTOR</b>		
p. 887	Change of description in <b>21.1 Functions of Voltage Detector</b>	(c)
p. 889	Change of note 2 and addition of notes 3, 4 to <b>Figure 21-2. Format of Voltage Detection Register (LVIM)</b>	(c)
p. 890	Change of <b>Figure 21-3. Format of Voltage Detection Level Select Register (LVIS)</b>	(c)
p. 891, 892	Change of <b>Table 21-1. LVD Operation Mode and Detection Voltage Settings for User Option Byte (000C1H/010C1H)</b>	(c)
p. 893	Change of description in <b>21.4.1 When used as reset mode</b>	(c)
p. 894	Change of <b>Figure 21-4. Timing of Voltage Detector Internal Reset Signal Generation (Option Byte LVIMDS1, LVIMDS0 = 1, 1)</b>	(c)
p. 895	Change of description in <b>21.4.2 When used as interrupt mode</b>	(c)
p. 896	Change of <b>Figure 21-5. Timing of Voltage Detector Internal Interrupt Signal Generation (Option Byte LVIMDS1, LVIMDS0 = 0, 1)</b>	(c)
p. 897	Change of description in <b>21.4.3 When used as interrupt and reset mode</b>	(c)
p. 898	Change of <b>Figure 21-6. Timing of Voltage Detector Reset Signal and Interrupt Signal Generation (Option Byte LVIMDS1, LVIMDS0 = 1, 0)</b>	(c)
p. 901	Change of <b>Figure 21-8. Delay from the time LVD reset source is generated until the time LVD reset has been generated or released</b>	(c)

**Remark** "Classification" in the above table classifies revisions as follows.

- (a): Error correction, (b): Addition/change of specifications, (c): Addition/change of description or note, (d): Addition/change of package, part number, or management division, (e): Addition/change of related documents



(7/7)

Page	Description	Classification
<b>CHAPTER 22 SAFETY FUNCTIONS</b>		
Though out	Change of all	(c)
<b>CHAPTER 23 REGULATOR</b>		
p. 920	Change of <b>23.1 Regulator Overview</b> and <b>Table 23-1. Regulator Output Voltage Conditions</b>	(c)
<b>CHAPTER 24 OPTION BYTE</b>		
p. 921	Change of description in <b>24.1.1 User option byte (000C0H to 000C2H/010C0H to 010C2H)</b>	(c)
p. 923	Change of caution in <b>Figure 24-1. Format of User Option Byte (000C0H/010C0H)</b>	(c)
p. 924, 925	Change of <b>Figure 24-2. Format of User Option Byte (000C1H/010C1H) (1/2)</b>	(c)
p. 926	Change of <b>Figure 24-3. Format of Option Byte (000C2H/010C2H)</b>	(c)
<b>CHAPTER 25 FLASH MEMORY</b>		
p. 931	Change of <b>Table 25-1. Wiring Between RL78/G13 and Dedicated Flash Memory Programmer</b>	(c)
p. 932	Change of <b>25.1.2 Communication Mode</b>	(c)
p. 934	Change of description in <b>25.2.2 Communication Mode</b>	(c)
p. 937, 938	Change of description in <b>25.4.1 Data flash overview</b>	(c)
p. 939	Change of description in <b>25.4.3 Procedure for accessing data flash memory</b>	(c)
p. 941	Change of description in <b>25.5.2 Flash memory programming mode</b>	(c)
p. 944	Addition of <b>25.5.5 Description of signature data</b>	(c)
p. 946	Change of <b>Table 25-12. Setting Security in Each Programming Mode</b>	(c)
p. 951	Change of <b>Table 25-14. Relationship between Flash Shield Window Function Setting/Change Methods and Commands</b>	(c)
<b>CHAPTER 26 ON-CHIP DEBUG FUNCTION</b>		
p. 954	Change of <b>Figure 26-2. Memory Spaces Where Debug Monitor Programs Are Allocated</b>	(c)
<b>CHAPTER 28 INSTRUCTION SET</b>		
p. 958	Change of description and deletion of remark in <b>CHAPTER 28 INSTRUCTION SET</b>	(c)
p. 962 to 978	Change of <b>28.2 Operation List</b>	(c)
<b>CHAPTER 29 ELECTRICAL SPECIFICATIONS</b>		
Though out	Addition of caution for pins of each products	(c)
p. 980, 981	Change of <b>29.2 Absolute Maximum Ratings</b>	(b), (c)
p. 983	Change of <b>29.3.2 On-chip oscillator characteristics</b>	(b), (c)
p. 985 to 987	Addition of <b>29.3.4 Recommended Oscillator Constants</b>	(b), (c)
p. 988 to 992	Change of <b>29.4.1 Pin characteristics</b>	(b), (c)
p. 993 to 1005	Change of <b>29.4.2 Supply current characteristics</b>	(b), (c)
p. 1006	Change of <b>29.5.1 Basic operation</b>	(b), (c)
p. 1008 to 1030	Change of <b>29.6.1 Serial array unit</b>	(b), (c)
p. 1032 to 1035	Change of <b>29.7.1 A/D converter characteristics</b>	(b), (c)
p. 1036	Change of <b>29.7.2 Temperature sensor characteristics</b> and <b>29.7.3 POR circuit characteristics</b>	(b), (c)
p. 1039	Change of <b>Supply Voltage Rise Time</b>	(b), (c)
p. 1040	Change of <b>29.8 Data Memory STOP Mode Low Supply Voltage Data Retention Characteristics</b> and <b>29.9 Flash Memory Programming Characteristics</b>	(b), (c)
p. 1041	Change of <b>29.10 Timing Specs for Switching Modes</b>	(b), (c)
<b>CHAPTER 30 PACKAGE DRAWINGS</b>		
Though out	Addition of <b>CHAPTER 30 PACKAGE DRAWINGS</b>	(b), (c)

**Remark** "Classification" in the above table classifies revisions as follows.

- (a): Error correction, (b): Addition/change of specifications, (c): Addition/change of description or note, (d): Addition/change of package, part number, or management division, (e): Addition/change of related documents

## &lt;R&gt; A.2 Revision History of Preceding Editions

Here is the revision history of the preceding editions. Chapter indicates the chapter of each edition.

(1/2)

Edition	Description	Chapter
Ver.0.07	Change of <b>1.1 Features</b>	<b>CHAPTER 1 PIN FUNCTIONS</b>
	Change of <b>1.6 Outline of Functions</b>	
	Change of <b>2.1 (5) 128-pin products</b>	<b>CHAPTER 2 PIN FUNCTIONS</b>
	Change of <b>2.1.12 80-pin products</b>	
	Change of <b>2.1.13 100-pin products</b>	
	Change of <b>2.1.14 128-pin products</b>	
	Change of <b>2.1.15 Pins for each product (pins other than port pins) (6/6)</b>	
	Change of caution in <b>2.2.5 (2) Control mode</b>	
	Change of <b>2.2.17 V<sub>DD</sub>, EV<sub>DD0</sub>, EV<sub>DD1</sub>, V<sub>SS</sub>, EV<sub>SS0</sub>, EV<sub>SS1</sub></b>	
	Change of Type 37-C in <b>Figure 2-1. Pin I/O Circuit List (1/2)</b>	
	Change of <b>Figure 3-1 to Figure 3-10</b>	
	Change of description of <b>3.1.2 Mirror area</b>	
	Change of <b>Figure 3-11. Format of Configuration of Processor Mode Control Register (PMC)</b>	
	Change of caution in <b>3.1.3 Internal data memory space</b>	
	Change of <b>Figure 3-12 to Figure 3-21</b>	
	Change of caution in <b>3.2.1 (3) Stack pointer (SP)</b>	
	Change of caution in <b>3.2.2 General-purpose registers</b>	
	Modification of <b>Table 3-1 Set Values of Internal Memory Size Switching Register (IMS) (78K0/KB2, and 38-pin products and 44-pin products of the 78K0/KC2) and Table 3-2 Set Values of Internal Memory Size Switching Register (IMS) and Internal Expansion RAM Size Switching Register (IXS) (48-pin products of the 78K0/KC2, 78K0/KD2, 78K0/KE2, and 78K0/KF2)</b>	<b>CHAPTER 3 CPU ARCHITECTURE</b>
	Addition of description in <b>3.2.1 (2) Program status word (PSW)</b>	
	Modification of <b>Notes 2 to 4 in Table 3-8 Special Function Register List (5/5)</b>	
	Change of <b>Table 4-1 (5) 128-pin products</b>	<b>CHAPTER 4 PORT FUNCTIONS</b>
	Deletion of note and caution 3 in <b>4.2.5 Port 4</b>	
	Change of <b>Figure 4-56. Block Diagram of P137</b>	
	Change of <b>Table 4-7. Settings of Port Mode Register, and Output Latch When Using Alternate Function (1/4)</b>	
Change of <b>5.1 (2) Subsystem clock</b>	<b>CHAPTER 5 CLOCK GENERATOR</b>	
Change of <b>Figure 5-1. Block Diagram of Clock Generator</b>		
Change of <b>Figure 5-10. Format of Internal High-Speed Oscillator Trimming Register (HIOTRM)</b>		
Change of <b>Figure 5-15. CPU Clock Status Transition Diagram</b>		



(2/2)

Edition	Description	Chapter
Ver.0.07	Change of note 2 in <b>Figure 6-8. Format of Timer Mode Register mn (TMRmn) (4/4)</b>	<b>CHAPTER 6 TIMER ARRAY UNIT</b>
	Change of <b>6. 3 (6) Timer channel start register m (TSm)</b>	
	Change of <b>Figure 6-42. Operation Procedure of Interval Timer/Square Wave Output Function (2/2)</b>	
	Change of <b>Figure 6-46. Operation Procedure When External Event Counter Function Is Used</b>	
	Change of <b>Figure 6-50. Operation Procedure When Frequency Divider Function Is Used</b>	
	Change of <b>Figure 6-62. Operation Procedure When Delay Counter Function Is Used</b>	
	Change of <b>Figure 6-67. Operation Procedure of One-Shot Pulse Output Function (2/2)</b>	
	Change of <b>Figure 6-72. Operation Procedure When PWM Function Is Used (2/2)</b>	
	Change of <b>Figure 6-77. Operation Procedure When Multiple PWM Output Function Is Used (2/2)</b>	
	Addition of cautions to <b>Figure 19-5. Format of Reset Control Flag Register (RESF)</b>	
Addition of caution to <b>Figure 22-6. Format of RAM Parity Error Control Register (RPECTL)</b>	<b>CHAPTER 22 SAFETY FUNCTIONS</b>	
Change of <b>Table 25-1. Wiring Between RL78/G13 and Dedicated Flash Memory Programmer</b>	<b>CHAPTER 25 FLASH MEMORY</b>	
Change of <b>Figure 25-2. Communication with Dedicated Flash Memory Programmer</b>		
Change of <b>Table 25-2. Pin Connection</b>		
Change of description of <b>25.4.1 Data flash overview</b>		
Change of description of <b>25.5.2 Flash memory programming mode</b>		
Change of <b>Table 25-7. Flash Memory Control Commands</b>		
Addition of caution to <b>25.7 Flash Memory Programming by Self-Programming</b>		
Change of <b>29.10 Timing Specs for Switching Modes</b>		<b>CHAPTER 29 ELECTRICAL SPECIFICATIONS (TARGET)</b>

---

RL78/G13 User's Manual: Hardware

Publication Date: Rev.1.00 Sep 22, 2011

Published by: Renesas Electronics Corporation

---

**SALES OFFICES**

Renesas Electronics Corporation

<http://www.renesas.com>Refer to "<http://www.renesas.com/>" for the latest and detailed information.

**Renesas Electronics America Inc.**  
2880 Scott Boulevard Santa Clara, CA 95050-2554, U.S.A.  
Tel: +1-408-588-6000, Fax: +1-408-588-6130

**Renesas Electronics Canada Limited**  
1101 Nicholson Road, Newmarket, Ontario L3Y 9C3, Canada  
Tel: +1-905-898-5441, Fax: +1-905-898-3220

**Renesas Electronics Europe Limited**  
Dukes Meadow, Millboard Road, Bourne End, Buckinghamshire, SL8 5FH, U.K  
Tel: +44-1628-585-100, Fax: +44-1628-585-900

**Renesas Electronics Europe GmbH**  
Arcadiastrasse 10, 40472 Düsseldorf, Germany  
Tel: +49-211-65030, Fax: +49-211-6503-1327

**Renesas Electronics (China) Co., Ltd.**  
7th Floor, Quantum Plaza, No.27 ZhiChunLu Haidian District, Beijing 100083, P.R.China  
Tel: +86-10-8235-1155, Fax: +86-10-8235-7679

**Renesas Electronics (Shanghai) Co., Ltd.**  
Unit 204, 205, AZIA Center, No.1233 Lujiazui Ring Rd., Pudong District, Shanghai 200120, China  
Tel: +86-21-5877-1818, Fax: +86-21-6887-7858 / -7898

**Renesas Electronics Hong Kong Limited**  
Unit 1601-1613, 16/F., Tower 2, Grand Century Place, 193 Prince Edward Road West, Mongkok, Kowloon, Hong Kong  
Tel: +852-2886-9318, Fax: +852-2886-9022/9044

**Renesas Electronics Taiwan Co., Ltd.**  
7F, No. 363 Fu Shing North Road Taipei, Taiwan  
Tel: +886-2-8175-9600, Fax: +886-2-8175-9670

**Renesas Electronics Singapore Pte. Ltd.**  
1 HarbourFront Avenue, #06-10, Keppel Bay Tower, Singapore 098632  
Tel: +65-6213-0200, Fax: +65-6278-8001

**Renesas Electronics Malaysia Sdn.Bhd.**  
Unit 906, Block B, Menara Amcorp, Amcorp Trade Centre, No. 18, Jln Persiaran Barat, 46050 Petaling Jaya, Selangor Darul Ehsan, Malaysia  
Tel: +60-3-7955-9390, Fax: +60-3-7955-9510

**Renesas Electronics Korea Co., Ltd.**  
11F., Samik Lavied' or Bldg., 720-2 Yeoksam-Dong, Kangnam-Ku, Seoul 135-080, Korea  
Tel: +82-2-558-3737, Fax: +82-2-558-5141

RL78/G13

## X-ON Electronics

Largest Supplier of Electrical and Electronic Components

*Click to view similar products for [16-bit Microcontrollers - MCU category](#):*

*Click to view products by [Renesas manufacturer](#):*

Other Similar products are found below :

[MB90F036APMC-GSE1](#) [MB90F342CASPMC-GSE1](#) [MB90F345CESPMC-GE1](#) [MB90F349CAPFR-GSE1](#) [MB90F428GCPFR-GSE1](#)  
[MB90F462APFM-GE1](#) [MB90F462APMC-G-SNE1](#) [MB90F497GPF-GE1](#) [MB90F546GSPFR-GE1](#) [MB90F947APFR-GS-SPE1](#)  
[MB96F346RSBPMC-GS-N2E2](#) [MB96F683RBPMC-GSAE1](#) [R5F11BGEAFB#30](#) [DF3026XBL25V](#) [S912ZVFP64F1VLL](#)  
[R4F24268NVRFQV](#) [R5F107DEGSP#X0](#) [R5F11B7EANA#U0](#) [R5F21172DSP#U0](#) [M30622F8PGP#U3C](#) [MB90092PF-G-BNDE1](#)  
[MB90F335APMC1-G-SPE1](#) [MB90F342CASPF-R-GS-N2E1](#) [MB90F345CAPFR-GSE1](#) [MB90F543GPF-GE1](#) [MB90F546GSPF-GE1](#)  
[MB90F568PMCR-GE1](#) [MB90F594APFR-GE1](#) [MB90F882ASPMC-GE1](#) [MB96F346RSAPQCR-GS-N2E2](#) [MB96F387RSBPMC-GSE2](#)  
[MB96F387RSBPMC-GS-N2E2](#) [MB96F395RSAPMC-GSE2](#) [MB96F623RBPMC1-GSE1](#) [MB96F646RBPMC-GSE1](#)  
[XE167F96F66LACFXUMA1](#) [MB96F696RBPMC-GSAE1](#) [MB96F018RBPMC-GSE1](#) [MB90F962SPMCR-GE1](#) [MB90F867ASPFR-GE1](#)  
[MB90F543GPF-G-FLE1](#) [MB90F345CESPF-GE1](#) [M30290FCHP#U3A](#) [DF2239FA20IV](#) [HD64F3672FPV](#) [R5F104AEASP#V0](#)  
[R5F100BCANA#U0](#) [R5F100BFANA#U0](#) [S9S12H256J2VFVER](#) [R5F100ACASP#V0](#)