

## 114 dB, 192-kHz 6-Ch CODEC with S/PDIF Receiver

### Features

- ◆ Six 24-bit D/A, two 24-bit A/D Converters
- ◆ 114 dB DAC / 114 dB ADC Dynamic Range
- ◆ -100 dB THD+N
- ◆ System Sampling Rates up to 192 kHz
- ◆ S/PDIF Receiver Compatible with EIAJ CP1201 and IEC-60958
- ◆ Recovered S/PDIF Clock or System Clock Selection
- ◆ 8:2 S/PDIF Input MUX
- ◆ ADC High-Pass Filter for DC Offset Calibration
- ◆ Expandable ADC Channels and One-Line Mode Support
- ◆ Digital Output Volume Control with Soft Ramp
- ◆ Digital  $\pm 15$  dB Input Gain Adjust for ADC
- ◆ Differential Analog Architecture
- ◆ Supports Logic Levels between 1.8 V and 5 V

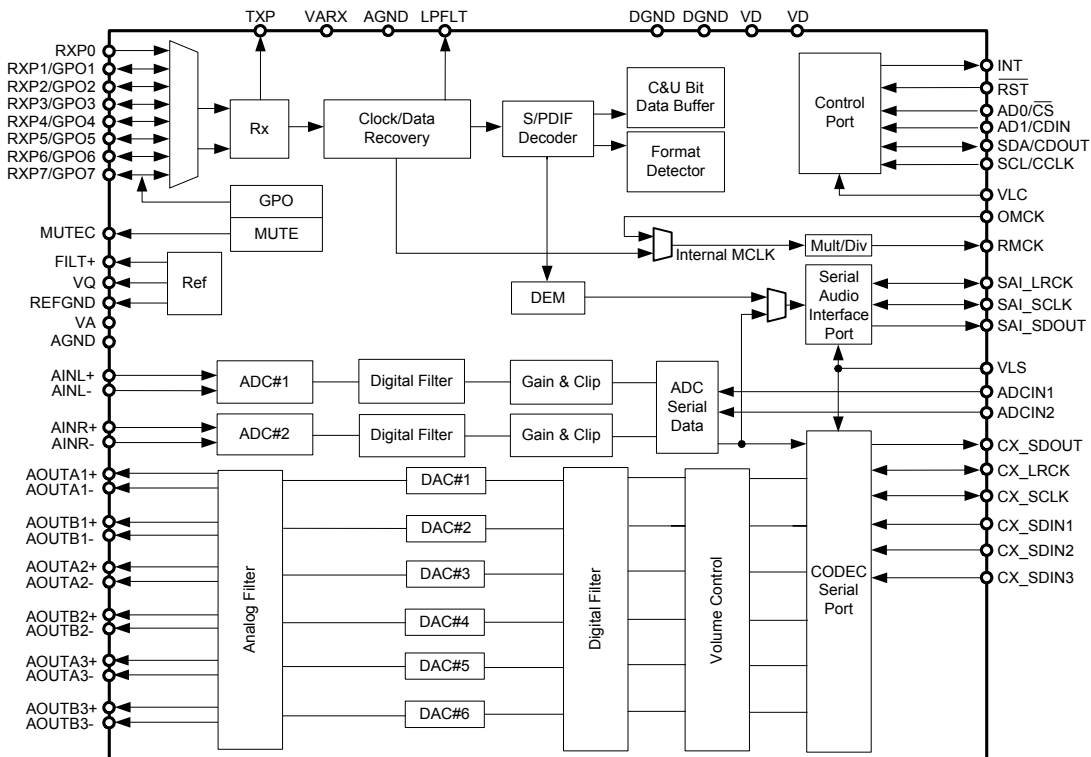
### General Description

The CS42526 provides two analog-to-digital and six digital-to-analog delta-sigma converters, as well as an integrated S/PDIF receiver.

The CS42526 integrated S/PDIF receiver supports up to eight inputs, clock recovery circuitry and format auto-detection. The internal stereo ADC is capable of independent channel gain control for single-ended or differential analog inputs. All six channels of DAC provide digital volume control and differential analog outputs. The general-purpose outputs may be driven high or low, or mapped to a variety of DAC mute controls or ADC overflow indicators.

The CS42526 is ideal for audio systems requiring wide dynamic range, negligible distortion and low noise, such as A/V receivers, DVD receivers, and digital speakers.

The CS42526 is available in a 64-pin LQFP package in Commercial ( $-10^{\circ}$  to  $+70^{\circ}$  C) grades. The CDB42528 Customer Demonstration board is also available for device evaluation. Refer to "Ordering Information" on page 90.



---

**TABLE OF CONTENTS**

<b>1. CHARACTERISTICS AND SPECIFICATIONS .....</b>	<b>6</b>
SPECIFIED OPERATING CONDITIONS .....	6
ABSOLUTE MAXIMUM RATINGS .....	6
ANALOG INPUT CHARACTERISTICS .....	7
A/D DIGITAL FILTER CHARACTERISTICS .....	8
ANALOG OUTPUT CHARACTERISTICS .....	9
D/A DIGITAL FILTER CHARACTERISTICS .....	10
SWITCHING CHARACTERISTICS .....	11
SWITCHING CHARACTERISTICS - CONTROL PORT - I <sup>2</sup> C™ FORMAT .....	12
SWITCHING CHARACTERISTICS - CONTROL PORT - SPI™ FORMAT .....	13
DC ELECTRICAL CHARACTERISTICS .....	14
DIGITAL INTERFACE CHARACTERISTICS .....	15
<b>2. PIN DESCRIPTIONS .....</b>	<b>16</b>
<b>3. TYPICAL CONNECTION DIAGRAM .....</b>	<b>19</b>
<b>4. APPLICATIONS .....</b>	<b>20</b>
4.1 Overview .....	20
4.2 Analog Inputs .....	20
4.2.1 Line-Level Inputs .....	20
4.2.2 High-Pass Filter and DC Offset Calibration .....	21
4.3 Analog Outputs .....	21
4.3.1 Line-Level Outputs and Filtering .....	21
4.3.2 Interpolation Filter .....	21
4.3.3 Digital Volume and Mute Control .....	22
4.3.4 ATAPI Specification .....	22
4.4 S/PDIF Receiver .....	23
4.4.1 8:2 S/PDIF Input Multiplexer .....	23
4.4.2 Error Reporting and Hold Function .....	23
4.4.3 Channel Status Data Handling .....	23
4.4.4 User Data Handling .....	23
4.4.5 Non-Audio Auto-Detection .....	23
4.5 Clock Generation .....	24
4.5.1 PLL and Jitter Attenuation .....	24
4.5.2 OMCK System Clock Mode .....	25
4.5.3 Master Mode .....	25
4.5.4 Slave Mode .....	25
4.6 Digital Interfaces .....	26
4.6.1 Serial Audio Interface Signals .....	26
4.6.2 Serial Audio Interface Formats .....	28
4.6.3 ADCIN1/ADCIN2 Serial Data Format .....	31
4.6.4 One-Line Mode (OLM) Configurations .....	32
4.6.4.1 OLM Config #1 .....	32
4.6.4.2 OLM Config #2 .....	33
4.6.4.3 OLM Config #3 .....	34
4.6.4.4 OLM Config #4 .....	35
4.6.4.5 OLM Config #5 .....	36
4.7 Control Port Description and Timing .....	37
4.7.1 SPI Mode .....	37
4.7.2 I <sup>2</sup> C Mode .....	38
4.8 Interrupts .....	39
4.9 Reset and Power-Up .....	39
4.10 Power Supply, Grounding, and PCB Layout .....	39
<b>5. REGISTER QUICK REFERENCE .....</b>	<b>41</b>

<b>6. REGISTER DESCRIPTION</b> .....	<b>45</b>
6.1 Memory Address Pointer (MAP) .....	45
6.2 Chip I.D. and Revision Register (address 01h) (Read Only) .....	45
6.3 Power Control (address 02h) .....	46
6.4 Functional Mode (address 03h) .....	47
6.5 Interface Formats (address 04h) .....	49
6.6 Misc Control (address 05h) .....	50
6.7 Clock Control (address 06h) .....	52
6.8 OMCK/PLL_CLK Ratio (address 07h) (Read Only) .....	53
6.9 RVCR Status (address 08h) (Read Only) .....	54
6.10 Burst Preamble PC and PD Bytes (addresses 09h - 0Ch)(Read Only) .....	55
6.11 Volume Transition Control (address 0Dh) .....	56
6.12 Channel Mute (address 0Eh) .....	58
6.13 Volume Control (addresses 0Fh, 10h, 11h, 12h, 13h, 14h) .....	58
6.14 Channel Invert (address 17h) .....	58
6.15 Mixing Control Pair 1 (Channels A1 & B1) (address 18h) Mixing Control Pair 2 (Channels A2 & B2) (address 19h) Mixing Control Pair 3 (Channels A3 & B3) (address 1Ah) .....	58
6.16 ADC Left Channel Gain (address 1Ch) .....	61
6.17 ADC Right Channel Gain (address 1Dh) .....	61
6.18 Receiver Mode Control (address 1Eh) .....	61
6.19 Receiver Mode Control 2 (address 1Fh) .....	63
6.20 Interrupt Status (address 20h) (Read Only) .....	63
6.21 Interrupt Mask (address 21h) .....	64
6.22 Interrupt Mode MSB (address 22h) Interrupt Mode LSB (address 23h) .....	65
6.23 Channel Status Data Buffer Control (address 24h) .....	65
6.24 Receiver Channel Status (address 25h) (Read Only) .....	66
6.25 Receiver Errors (address 26h) (Read Only) .....	67
6.26 Receiver Errors Mask (address 27h) .....	68
6.27 Mutec Pin Control (address 28h) .....	69
6.28 RXP/General-Purpose Pin Control (addresses 29h to 2Fh) .....	69
6.29 Q-Channel Subcode Bytes 0 to 9 (addresses 30h to 39h) (Read Only) .....	71
6.30 C-Bit or U-Bit Data Buffer (addresses 3Ah to 51h) (Read Only) .....	71
<b>7. PARAMETER DEFINITIONS</b> .....	<b>72</b>
<b>8. APPENDIX A: EXTERNAL FILTERS</b> .....	<b>73</b>
8.1 ADC Input Filter .....	73
8.2 DAC Output Filter .....	73
<b>9. APPENDIX B: S/PDIF RECEIVER</b> .....	<b>74</b>
9.1 Error Reporting and Hold Function .....	74
9.2 Channel Status Data Handling .....	74
9.2.1 Channel Status Data E Buffer Access .....	75
9.2.1.1 One-Byte Mode .....	75
9.2.1.2 Two-Byte Mode .....	75
9.2.2 Serial Copy Management System (SCMS) .....	76
9.3 User (U) Data E Buffer Access .....	76
9.3.1 Non-Audio Auto-Detection .....	76
9.3.1.1 Format Detection .....	76
<b>10. APPENDIX C: PLL FILTER</b> .....	<b>77</b>
10.1 External Filter Components .....	77
10.1.1 General .....	77
10.1.2 Jitter Attenuation .....	79
10.1.3 Capacitor Selection .....	80
10.1.4 Circuit Board Layout .....	81

<b>11. APPENDIX D: EXTERNAL AES3-S/PDIF-IEC60958 RECEIVER COMPONENTS</b> .....	<b>82</b>
11.1 AES3 Receiver External Components .....	82
<b>12. APPENDIX E: ADC FILTER PLOTS</b> .....	<b>83</b>
<b>13. APPENDIX F: DAC FILTER PLOTS</b> .....	<b>85</b>
<b>14. PACKAGE DIMENSIONS</b> .....	<b>89</b>
THERMAL CHARACTERISTICS .....	89
<b>15. ORDERING INFORMATION</b> .....	<b>90</b>
<b>16. REFERENCES</b> .....	<b>90</b>
<b>17. REVISION HISTORY</b> .....	<b>91</b>

## LIST OF FIGURES

Figure 1. Serial Audio Port Master Mode Timing .....	11
Figure 2. Serial Audio Port Slave Mode Timing .....	11
Figure 3. Control Port Timing - I <sup>2</sup> C Format .....	12
Figure 4. Control Port Timing - SPI Format .....	13
Figure 5. Typical Connection Diagram .....	19
Figure 6. Full-Scale Analog Input .....	20
Figure 7. Full-Scale Output .....	21
Figure 8. ATAPI Block Diagram (x = channel pair 1, 2, or 3) .....	22
Figure 9. CS42526 Clock Generation .....	24
Figure 10. I <sup>2</sup> S Serial Audio Formats .....	28
Figure 11. Left-Justified Serial Audio Formats .....	29
Figure 12. Right-Justified Serial Audio Formats .....	29
Figure 13. One Line Mode #1 Serial Audio Format .....	30
Figure 14. One Line Mode #2 Serial Audio Format .....	30
Figure 15. ADCIN1/ADCIN2 Serial Audio Format .....	31
Figure 16. OLM Configuration #1 .....	32
Figure 17. OLM Configuration #2 .....	33
Figure 18. OLM Configuration #3 .....	34
Figure 19. OLM Configuration #4 .....	35
Figure 20. OLM Configuration #5 .....	36
Figure 21. Control Port Timing in SPI Mode .....	37
Figure 22. Control Port Timing, I <sup>2</sup> C Write .....	38
Figure 23. Control Port Timing, I <sup>2</sup> C Read .....	38
Figure 24. Recommended Analog Input Buffer .....	73
Figure 25. Recommended Analog Output Buffer .....	73
Figure 26. Channel Status Data Buffer Structure .....	75
Figure 27. PLL Block Diagram .....	77
Figure 28. Jitter-Attenuation Characteristics of PLL - Configurations 1 & 2 .....	79
Figure 29. Jitter-Attenuation Characteristics of PLL - Configuration 3 .....	79
Figure 30. Recommended Layout Example .....	81
Figure 31. Consumer Input Circuit .....	82
Figure 32. S/PDIF MUX Input Circuit .....	82
Figure 33. TTL/CMOS Input Circuit .....	82
Figure 34. Single-Speed Mode Stopband Rejection .....	83
Figure 35. Single-Speed Mode Transition Band .....	83
Figure 36. Single-Speed Mode Transition Band (Detail) .....	83
Figure 37. Single-Speed Mode Passband Ripple .....	83
Figure 38. Double-Speed Mode Stopband Rejection .....	83
Figure 39. Double-Speed Mode Transition Band .....	83
Figure 40. Double-Speed Mode Transition Band (Detail) .....	84
Figure 41. Double-Speed Mode Passband Ripple .....	84
Figure 42. Quad-Speed Mode Stopband Rejection .....	84

Figure 43. Quad-Speed Mode Transition Band .....	84
Figure 44. Quad-Speed Mode Transition Band (Detail) .....	84
Figure 45. Quad-Speed Mode Passband Ripple .....	84
Figure 46. Single-Speed (fast) Stopband Rejection .....	85
Figure 47. Single-Speed (fast) Transition Band .....	85
Figure 48. Single-Speed (fast) Transition Band (detail) .....	85
Figure 49. Single-Speed (fast) Passband Ripple .....	85
Figure 50. Single-Speed (slow) Stopband Rejection .....	85
Figure 51. Single-Speed (slow) Transition Band .....	85
Figure 52. Single-Speed (slow) Transition Band (detail) .....	86
Figure 53. Single-Speed (slow) Passband Ripple .....	86
Figure 54. Double-Speed (fast) Stopband Rejection .....	86
Figure 55. Double-Speed (fast) Transition Band .....	86
Figure 56. Double-Speed (fast) Transition Band (detail) .....	86
Figure 57. Double-Speed (fast) Passband Ripple .....	86
Figure 58. Double-Speed (slow) Stopband Rejection .....	87
Figure 59. Double-Speed (slow) Transition Band .....	87
Figure 60. Double-Speed (slow) Transition Band (detail) .....	87
Figure 61. Double-Speed (slow) Passband Ripple .....	87
Figure 62. Quad-Speed (fast) Stopband Rejection .....	87
Figure 63. Quad-Speed (fast) Transition Band .....	87
Figure 64. Quad-Speed (fast) Transition Band (detail) .....	88
Figure 65. Quad-Speed (fast) Passband Ripple .....	88
Figure 66. Quad-Speed (slow) Stopband Rejection .....	88
Figure 67. Quad-Speed (slow) Transition Band .....	88
Figure 68. Quad-Speed (slow) Transition Band (detail) .....	88
Figure 69. Quad-Speed (slow) Passband Ripple .....	88

## LIST OF TABLES

Table 1. Common OMCK Clock Frequencies .....	25
Table 2. Common PLL Output Clock Frequencies.....	25
Table 3. Slave Mode Clock Ratios .....	26
Table 4. Serial Audio Port Channel Allocations .....	27
Table 5. DAC De-Emphasis .....	48
Table 6. Receiver De-Emphasis .....	48
Table 7. Digital Interface Formats .....	49
Table 8. ADC One-Line Mode.....	49
Table 9. DAC One-Line Mode.....	49
Table 10. RMCK Divider Settings .....	52
Table 11. OMCK Frequency Settings .....	52
Table 12. Master Clock Source Select.....	53
Table 13. AES Format Detection .....	54
Table 14. Receiver Clock Frequency Detection.....	55
Table 15. Example Digital Volume Settings .....	58
Table 16. ATAPI Decode .....	60
Table 17. Example ADC Input Gain Settings .....	61
Table 18. TXP Output Selection.....	63
Table 19. Receiver Input Selection .....	63
Table 20. Auxiliary Data Width Selection .....	66
Table 21. External PLL Component Values & Locking Modes .....	77

## 1. CHARACTERISTICS AND SPECIFICATIONS

(All Min/Max characteristics and specifications are guaranteed over the Specified Operating Conditions. Typical performance characteristics and specifications are derived from measurements taken at nominal supply voltages and  $T_A = 25^\circ \text{C}$ .)

### SPECIFIED OPERATING CONDITIONS

(AGND=DGND=0, all voltages with respect to ground; OMCK=12.288 MHz; Master Mode)

Parameter	Symbol	Min	Typ	Max	Units	
DC Power Supply	Analog	VA / VARX	4.75	5.0	5.25	V
	Digital	VD	3.13	3.3	5.25	V
	Serial Port Interface	VLS	1.8	5.0	5.25	V
	Control Port Interface	VLC	1.8	5.0	5.25	V
Ambient Operating Temperature (power applied)	$T_A$	-10	-	+70	$^\circ\text{C}$	

### ABSOLUTE MAXIMUM RATINGS

(AGND = DGND = 0 V; all voltages with respect to ground.)

Parameters	Symbol	Min	Max	Units	
DC Power Supply	Analog	VA / VARX	-0.3	6.0	V
	Digital	VD	-0.3	6.0	V
	Serial Port Interface	VLS	-0.3	6.0	V
	Control Port Interface	VLC	-0.3	6.0	V
Input Current	(Note 1) $I_{in}$	-	$\pm 10$	mA	
Analog Input Voltage	(Note 2) $V_{IN}$	AGND-0.7	VA+0.7	V	
Digital Input Voltage	Serial Port Interface	$V_{IND-S}$	-0.3	VLS+ 0.4	V
	Control Port Interface	$V_{IND-C}$	-0.3	VLC+ 0.4	V
	S/PDIF interface	$V_{IND-SP}$	-0.3	VARX+0.4	V
Ambient Operating Temperature(power applied)	$T_A$	-20	+85	$^\circ\text{C}$	
	$T_A$	-50	+95	$^\circ\text{C}$	
Storage Temperature	$T_{stg}$	-65	+150	$^\circ\text{C}$	

**WARNING:** Operation at or beyond these limits may result in permanent damage to the device. Normal operation is not guaranteed at these extremes.

#### Notes:

- Any pin except supplies. Transient currents of up to  $\pm 100$  mA on the analog input pins will not cause SCR latch-up.
- The maximum over/under voltage is limited by the input current.

## ANALOG INPUT CHARACTERISTICS

( $T_A = 25^\circ\text{C}$ ;  $V_A = \text{VARX} = 5\text{ V}$ ,  $V_D = 3.3\text{ V}$ , Logic “0” = DGND = AGND = 0 V; Logic “1” = VLS = VLC = 5 V; Measurement Bandwidth is 10 Hz to 20 kHz unless otherwise specified. Full-scale input sine wave, 997 Hz.; PDN\_RCVR = 1; SW\_CTRL[1:0] = ‘01’; OMCK = 12.288 MHz; Single-Speed Mode CX\_SCLK = 3.072 MHz; Double-Speed Mode CX\_SCLK = 6.144 MHz; Quad-Speed Mode CX\_SCLK = 12.288 MHz.)

Parameter	Symbol	Min	Typ	Max	Unit
<b>Single-Speed Mode (Fs=48 kHz)</b>					
Dynamic Range	A-weighted	108	114	-	dB
	unweighted	105	111	-	dB
Total Harmonic Distortion + Noise (Note 3)	-1 dB	-	-100	-94	dB
	-20 dB	-	-91	-	dB
	-60 dB	-	-51	-	dB
<b>Double-Speed Mode (Fs=96 kHz)</b>					
Dynamic Range	A-weighted	108	114	-	dB
	unweighted	105	111	-	dB
	40 kHz bandwidth unweighted	-	108	-	dB
Total Harmonic Distortion + Noise (Note 3)	-1 dB	-	-100	-94	dB
	-20 dB	-	-91	-	dB
	-60 dB	-	-51	-	dB
	40 kHz bandwidth -1 dB	-	-97	-	dB
<b>Quad-Speed Mode (Fs=192 kHz)</b>					
Dynamic Range	A-weighted	108	114	-	dB
	unweighted	105	111	-	dB
	40 kHz bandwidth unweighted	-	108	-	dB
Total Harmonic Distortion+ Noise (Note 3)	-1 dB	-	-100	-94	dB
	-20 dB	-	-91	-	dB
	-60 dB	-	-51	-	dB
	40 kHz bandwidth -1 dB	-	-97	-	dB
<b>Dynamic Performance for All Modes</b>					
Interchannel Isolation		-	110	-	dB
Interchannel Phase Deviation		-	0.0001	-	Degree
<b>DC Accuracy</b>					
Interchannel Gain Mismatch		-	0.1	-	dB
Gain Drift		-	+/-100	-	ppm/°C
Offset Error	HPF_FREEZE disabled	-	0	-	LSB
	HPF_FREEZE enabled	-	100	-	LSB
<b>Analog Input</b>					
Full-scale Differential Input Voltage		1.05 VA	1.10 VA	1.16 VA	Vpp
Input Impedance (Differential) (Note 4)		17	-	-	kΩ
Common Mode Rejection Ratio	CMRR	-	82	-	dB

### Notes:

3. Referred to the typical full-scale voltage.
4. Measured between AIN+ and AIN-

**A/D DIGITAL FILTER CHARACTERISTICS**

Parameter	Symbol	Min	Typ	Max	Unit
<b>Single-Speed Mode (2 to 50 kHz sample rates)</b>					
Passband (-0.1 dB) (Note 5)		0	-	0.47	Fs
Passband Ripple		-	-	±0.035	dB
Stopband (Note 5)		0.58	-	-	Fs
Stopband Attenuation		-95	-	-	dB
Total Group Delay (Fs = Output Sample Rate)	$t_{gd}$	-	12/Fs	-	s
Group Delay Variation vs. Frequency	$\Delta t_{gd}$	-	-	0.0	μs
<b>Double-Speed Mode (50 to 100 kHz sample rates)</b>					
Passband (-0.1 dB) (Note 5)		0	-	0.45	Fs
Passband Ripple		-	-	±0.035	dB
Stopband (Note 5)		0.68	-	-	Fs
Stopband Attenuation		-92	-	-	dB
Total Group Delay (Fs = Output Sample Rate)	$t_{gd}$	-	9/Fs	-	s
Group Delay Variation vs. Frequency	$\Delta t_{gd}$	-	-	0.0	μs
<b>Quad-Speed Mode (100 to 192 kHz sample rates)</b>					
Passband (-0.1 dB) (Note 5)		0	-	0.24	Fs
Passband Ripple		-	-	±0.035	dB
Stopband (Note 5)		0.78	-	-	Fs
Stopband Attenuation		-97	-	-	dB
Total Group Delay (Fs = Output Sample Rate)	$t_{gd}$	-	5/Fs	-	s
Group Delay Variation vs. Frequency	$\Delta t_{gd}$	-	-	0.0	μs
<b>High-Pass Filter Characteristics</b>					
Frequency Response -3.0 dB		-	1	-	Hz
-0.13 dB (Note 6)		-	20	-	Hz
Phase Deviation @ 20 Hz (Note 6)		-	10	-	Deg
Passband Ripple		-	-	0	dB
Filter Setting Time		-	10 <sup>9</sup> /Fs	-	s

**Notes:**

5. The filter frequency response scales precisely with Fs.
6. Response shown is for Fs equal to 48 kHz. Filter characteristics scale with Fs.



## ANALOG OUTPUT CHARACTERISTICS

( $T_A = 25^\circ\text{C}$ ;  $V_A = \text{VARX} = 5\text{ V}$ ,  $V_D = 3.3\text{ V}$ , Logic "0" = DGND = AGND = 0 V; Logic "1" = VLS = VLC = 5V; Measurement Bandwidth 10 Hz to 20 kHz unless otherwise specified.; Full-scale output 997 Hz sine wave, Test load  $R_L = 3\text{ k}\Omega$ ,  $C_L = 30\text{ pF}$ ; PDN\_RCVR = 1; SW\_CTRL[1:0] = '01'; OMCK = 12.288 MHz; Single-Speed Mode, CX\_SCLK = 3.072 MHz; Double-Speed Mode, CX\_SCLK = 6.144 MHz; Quad-Speed Mode, CX\_SCLK = 12.288 MHz.)

Parameter	Symbol	Min	Typ	Max	Unit
<b>Dynamic performance for all modes</b>					
Dynamic Range (Note 7)					
24-bit A-Weighted unweighted		108	114	-	dB
16-bit A-Weighted (Note 8) unweighted		-	97	-	dB
		105	111	-	dB
		-	94	-	dB
Total Harmonic Distortion + Noise					
24-bit 0 dB	THD+N	-	-100	-94	dB
24-bit -20 dB		-	-91	-	dB
24-bit -60 dB		-	-51	-	dB
16-bit 0 dB		-	-94	-	dB
16-bit (Note 8) -20 dB		-	-74	-	dB
16-bit (Note 8) -60 dB		-	-34	-	dB
Idle Channel Noise/Signal-to-Noise Ratio (A-Weighted)		-	114	-	dB
Interchannel Isolation (1 kHz)		-	90	-	dB
<b>Analog Output Characteristics for all modes</b>					
Unloaded Full-Scale Differential Output Voltage	$V_{FS}$	.89 VA	.94 VA	.99 VA	Vpp
Interchannel Gain Mismatch		-	0.1	-	dB
Gain Drift		-	300	-	ppm/°C
Output Impedance	$Z_{OUT}$	-	150	-	$\Omega$
AC-Load Resistance	$R_L$	3	-	-	k $\Omega$
Load Capacitance	$C_L$	-	-	30	pF

### Notes:

7. One LSB of triangular PDF dither is added to data.
8. Performance limited by 16-bit quantization noise.

**D/A DIGITAL FILTER CHARACTERISTICS**

Parameter	Fast Roll-Off			Slow Roll-Off			Unit	
	Min	Typ	Max	Min	Typ	Max		
<b>Combined Digital and On-chip Analog Filter Response - Single-Speed Mode - 48 kHz</b>								
Passband (Note 9)	to -0.01 dB corner	0	-	0.4535	0	-	0.4166	Fs
	to -3 dB corner	0	-	0.4998	0	-	0.4998	Fs
Frequency Response 10 Hz to 20 kHz	-0.01	-	+0.01	-0.01	-	+0.01		dB
StopBand	0.5465	-	-	0.5834	-	-		Fs
StopBand Attenuation (Note 10)	90	-	-	64	-	-		dB
Group Delay	-	12/Fs	-	-	6.5/Fs	-		s
Passband Group Delay Deviation 0 - 20 kHz	-	-	±0.41/Fs	-	-	±0.14/Fs		s
De-emphasis Error (Note 11) (Relative to 1 kHz)	Fs = 32 kHz	-	-	±0.23	-	-	±0.23	dB
	Fs = 44.1 kHz	-	-	±0.14	-	-	±0.14	dB
	Fs = 48 kHz	-	-	±0.09	-	-	±0.09	dB
<b>Combined Digital and On-chip Analog Filter Response - Double-Speed Mode - 96 kHz</b>								
Passband (Note 9)	to -0.01 dB corner	0	-	0.4166	0	-	0.2083	Fs
	to -3 dB corner	0	-	0.4998	0	-	0.4998	Fs
Frequency Response 10 Hz to 20 kHz	-0.01	-	0.01	-0.01	-	0.01		dB
StopBand	0.5834	-	-	0.7917	-	-		Fs
StopBand Attenuation (Note 10)	80	-	-	70	-	-		dB
Group Delay	-	4.6/Fs	-	-	3.9/Fs	-		s
Passband Group Delay Deviation 0 - 20 kHz	-	-	±0.03/Fs	-	-	±0.01/Fs		s
<b>Combined Digital and On-chip Analog Filter Response - Quad-Speed Mode - 192 kHz</b>								
Passband (Note 9)	to -0.01 dB corner	0	-	0.1046	0	-	0.1042	Fs
	to -3 dB corner	0	-	0.4897	0	-	0.4813	Fs
Frequency Response 10 Hz to 20 kHz	-0.01	-	0.01	-0.01	-	0.01		dB
StopBand	0.6355	-	-	0.8683	-	-		Fs
StopBand Attenuation (Note 10)	90	-	-	75	-	-		dB
Group Delay	-	4.7/Fs	-	-	4.2/Fs	-		s
Passband Group Delay Deviation 0 - 20 kHz	-	-	±0.01/Fs	-	-	±0.01/Fs		s

**Notes:**

9. Response is clock dependent and will scale with Fs. Note that the response plots (Figures 46 to 69) have been normalized to Fs and can be de-normalized by multiplying the X-axis scale by Fs.
10. Single- and Double-Speed Mode Measurement Bandwidth is from stopband to 3 Fs.  
Quad-Speed Mode Measurement Bandwidth is from stopband to 1.34 Fs.
11. De-emphasis is available only in Single-Speed Mode.

## SWITCHING CHARACTERISTICS

( $T_A = -10$  to  $+70^\circ\text{C}$ ;  $V_A = \text{VARX} = 5\text{V}$ ,  $V_D = \text{VLC} = 3.3\text{V}$ ,  $V_{LS} = 1.8\text{V}$  to  $5.25\text{V}$ ; Inputs: Logic 0 = DGND, Logic 1 = VLS,  $C_L = 30\text{pF}$ )

Parameters	Symbol	Min	Typ	Max	Units
$\overline{\text{RST}}$ Pin Low Pulse Width (Note 12)		1	-	-	ms
PLL Clock Recovery Sample Rate Range		30	-	200	kHz
RMCK Output Jitter (Note 14)		-	200	-	ps RMS
RMCK Output Duty Cycle (Note 15)		45	50	55	%
OMCK Frequency (Note 13)		1.024	-	25.600	MHz
OMCK Duty Cycle (Note 13)		40	50	60	%
CX_SCLK, SAI_SCLK Duty Cycle		45	50	55	%
CX_LRCK, SAI_LRCK Duty Cycle		45	50	55	%
<b>Master Mode</b>					
RMCK to CX_SCLK, SAI_SCLK active edge delay	$t_{\text{smd}}$	0	-	15	ns
RMCK to CX_LRCK, SAI_LRCK delay	$t_{\text{lmd}}$	0	-	15	ns
<b>Slave Mode</b>					
CX_SCLK, SAI_SCLK Falling Edge to CX_SDOU, SAI_SDOU Output Valid	$t_{\text{dpd}}$		-	(Note 16)	ns
CX_LRCK, SAI_LRCK Edge to MSB Valid	$t_{\text{lrpd}}$		-	26.5	ns
CX_SDIN Setup Time Before CX_SCLK Rising Edge	$t_{\text{ds}}$	10	-	-	ns
CX_SDIN Hold Time After CX_SCLK Rising Edge	$t_{\text{dh}}$	30	-	-	ns
CX_SCLK, SAI_SCLK High Time	$t_{\text{sckh}}$	20	-	-	ns
CX_SCLK, SAI_SCLK Low Time	$t_{\text{sckl}}$	20	-	-	ns
CX_SCLK, SAI_SCLK falling to CX_LRCK, SAI_LRCK Edge	$t_{\text{lrck}}$	-25	-	+25	ns

### Notes:

12. After powering-up the CS42526,  $\overline{\text{RST}}$  should be held low after the power supplies and clocks are settled.
13. See [Table 1 on page 25](#) for suggested OMCK frequencies
14. Limit the loading on RMCK to 1 CMOS load if operating above 24.576 MHz.
15. Not valid when RMCK\_DIV in “Clock Control (address 06h)” on [page 52](#) is set to Multiply by 2.
16. 76.5 ns for Single-Speed and Double-Speed modes, 23 ns for Quad-Speed Mode.

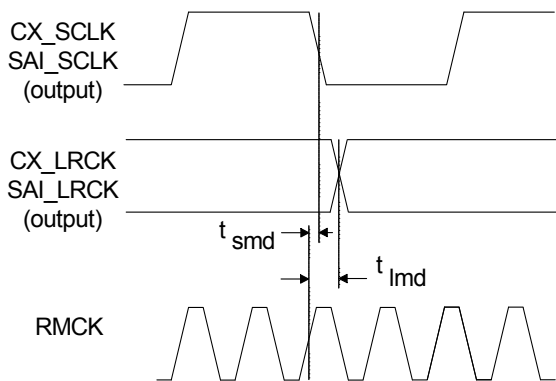


Figure 1. Serial Audio Port Master Mode Timing

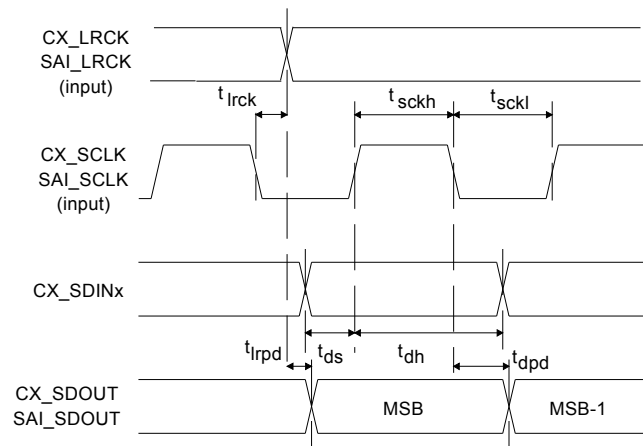


Figure 2. Serial Audio Port Slave Mode Timing

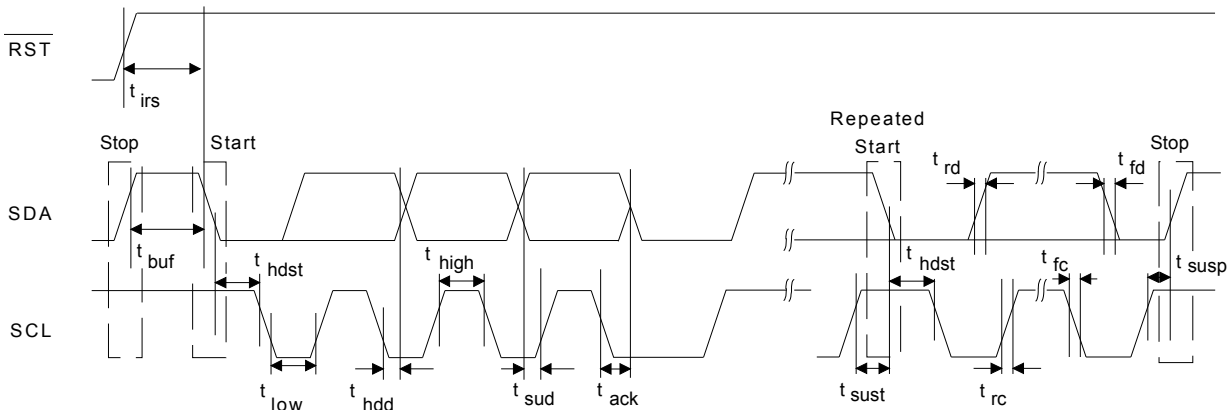
**SWITCHING CHARACTERISTICS - CONTROL PORT - I<sup>2</sup>C™ FORMAT**

(T<sub>A</sub> = -10 to +70° C; V<sub>A</sub>=V<sub>ARX</sub> = 5 V, V<sub>D</sub> =V<sub>LS</sub>= 3.3 V; V<sub>L</sub>C = 1.8 V to 5.25 V; Inputs: Logic 0 = DGND, Logic 1 = V<sub>L</sub>C, C<sub>L</sub> = 30 pF)

Parameter	Symbol	Min	Max	Unit
SCL Clock Frequency	f <sub>scl</sub>	-	100	kHz
RST Rising Edge to Start	t <sub>irs</sub>	500	-	ns
Bus Free Time Between Transmissions	t <sub>buf</sub>	4.7	-	μs
Start Condition Hold Time (prior to first clock pulse)	t <sub>hdst</sub>	4.0	-	μs
Clock Low time	t <sub>low</sub>	4.7	-	μs
Clock High Time	t <sub>high</sub>	4.0	-	μs
Setup Time for Repeated Start Condition	t <sub>sust</sub>	4.7	-	μs
SDA Hold Time from SCL Falling (Note 17)	t <sub>hdd</sub>	0	-	μs
SDA Setup time to SCL Rising	t <sub>sud</sub>	250	-	ns
Rise Time of SCL and SDA	t <sub>rc</sub>	-	1	μs
Fall Time SCL and SDA	t <sub>fc</sub>	-	300	ns
Setup Time for Stop Condition	t <sub>susp</sub>	4.7	-	μs
Acknowledge Delay from SCL Falling (Note 18)	t <sub>ack</sub>	-	(Note 19)	ns

**Notes:**

17. Data must be held for sufficient time to bridge the transition time, t<sub>fc</sub>, of SCL.
18. The acknowledge delay is based on MCLK and can limit the maximum transaction speed.
19.  $\frac{15}{256 \times F_s}$  for Single-Speed Mode,  $\frac{15}{128 \times F_s}$  for Double-Speed Mode,  $\frac{15}{64 \times F_s}$  for Quad-Speed Mode


**Figure 3. Control Port Timing - I<sup>2</sup>C Format**

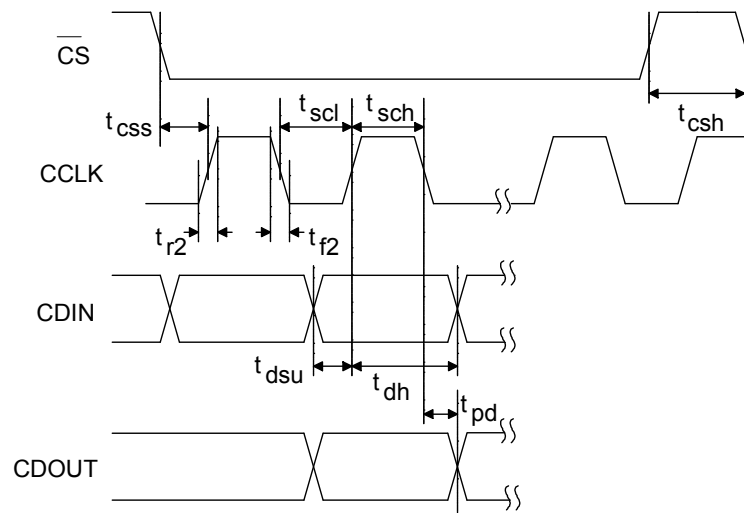
**SWITCHING CHARACTERISTICS - CONTROL PORT - SPI™ FORMAT**

( $T_A = -10$  to  $+70^\circ\text{C}$ ;  $V_A = V_{ARX} = 5\text{V}$ ,  $V_D = V_{LS} = 3.3\text{V}$ ;  $V_{LC} = 1.8\text{V}$  to  $5.25\text{V}$ ; Inputs: Logic 0 = DGND, Logic 1 = VLC,  $C_L = 30\text{pF}$ )

Parameter	Symbol	Min	Typ	Max	Units
CCLK Clock Frequency (Note 20)	$f_{sck}$	0	-	6.0	MHz
CS High Time Between Transmissions	$t_{csh}$	1.0	-	-	$\mu\text{s}$
CS Falling to CCLK Edge	$t_{css}$	20	-	-	ns
CCLK Low Time	$t_{scl}$	66	-	-	ns
CCLK High Time	$t_{sch}$	66	-	-	ns
CDIN to CCLK Rising Setup Time	$t_{dsu}$	40	-	-	ns
CCLK Rising to DATA Hold Time (Note 21)	$t_{dh}$	15	-	-	ns
CCLK Falling to CDOUT Stable	$t_{pd}$	-	-	50	ns
Rise Time of CDOUT	$t_{r1}$	-	-	25	ns
Fall Time of CDOUT	$t_{f1}$	-	-	25	ns
Rise Time of CCLK and CDIN (Note 22)	$t_{r2}$	-	-	100	ns
Fall Time of CCLK and CDIN (Note 22)	$t_{f2}$	-	-	100	ns

**Notes:**

20. If  $F_s$  is lower than 46.875 kHz, the maximum CCLK frequency should be less than 128  $F_s$ . This is dictated by the timing requirements necessary to access the Channel Status and User Bit buffer memory. Access to the control register file can be carried out at the full 6 MHz rate. The minimum allowable input sample rate is 8 kHz, so choosing CCLK to be less than or equal to 1.024 MHz should be safe for all possible conditions.
21. Data must be held for sufficient time to bridge the transition time of CCLK.
22. For  $f_{sck} < 1\text{MHz}$ .



**Figure 4. Control Port Timing - SPI Format**

**DC ELECTRICAL CHARACTERISTICS**

(T<sub>A</sub> = 25° C; AGND=DGND=0, all voltages with respect to ground; OMCK=12.288 MHz; Master Mode)

Parameter	Symbol	Min	Typ	Max	Units	
Power Supply Current (Note 23)	normal operation, V <sub>A</sub> = V <sub>ARX</sub> = 5 V	I <sub>A</sub>	-	75	-	mA
	VD = 5 V	I <sub>D</sub>	-	85	-	mA
	VD = 3.3 V	I <sub>D</sub>	-	51	-	mA
	Interface current, V <sub>LC</sub> =5 V (Note 24)	I <sub>LC</sub>	-	250	-	μA
	V <sub>LS</sub> =5 V	I <sub>LS</sub>	-	13	-	mA
	power-down state (all supplies) (Note 25)	I <sub>pd</sub>	-	250	-	μA
Power Consumption (Note 23)	V <sub>A</sub> =V <sub>ARX</sub> =5 V, V <sub>D</sub> =V <sub>LS</sub> =V <sub>LC</sub> =3.3 V		-	587	650	mW
	normal operation		-	1.25	-	mW
	power-down (Note 25)		-	866	960	mW
	V <sub>A</sub> =V <sub>ARX</sub> =5 V, V <sub>D</sub> =V <sub>LS</sub> =V <sub>LC</sub> =5 V		-	1.25	-	mW
Power Supply Rejection Ratio (Note 26)	(1 kHz)	PSRR	-	60	-	dB
	(60 Hz)		-	40	-	dB
VQ Nominal Voltage		-	2.7	-	V	
VQ Output Impedance		-	50	-	kΩ	
VQ Maximum allowable DC current		-	0.01	-	mA	
FILT+ Nominal Voltage		-	5.0	-	V	
FILT+ Output Impedance		-	35	-	kΩ	
FILT+ Maximum allowable DC current		-	0.01	-	mA	

**Notes:**

23. Current consumption increases with increasing FS and increasing OMCK. Max values are based on highest FS and highest OMCK. Variance between speed modes is negligible.
24. I<sub>LC</sub> measured with no external loading on the SDA pin.
25. Power-Down Mode is defined as  $\overline{RST}$  pin = Low with all clock and data lines held static.
26. Valid with the recommended capacitor values on FILT+ and VQ as shown in Figure 5.

**DIGITAL INTERFACE CHARACTERISTICS**

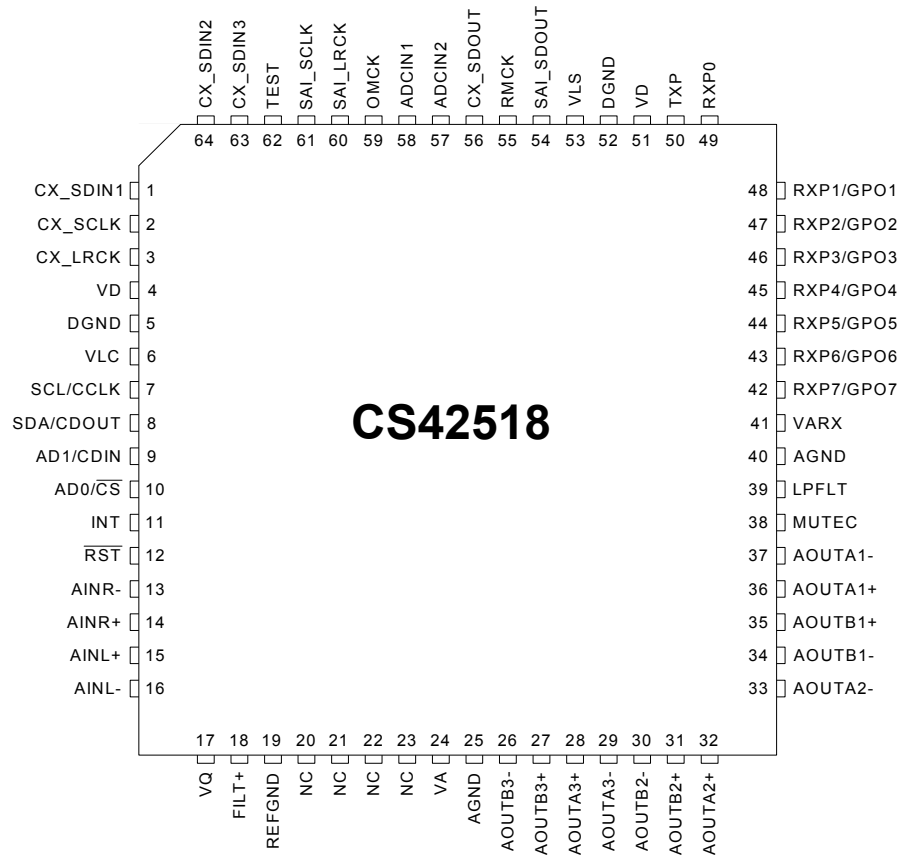
 (T<sub>A</sub> = +25° C)

Parameters (Note 27)	Symbol	Min	Typ	Max	Units	
High-Level Input Voltage	Serial Port	V <sub>IH</sub>	0.7xVLS	-	-	V
	Control Port		0.7xVLC	-	-	V
Low-Level Input Voltage	Serial Port	V <sub>IL</sub>	-	-	0.2xVLS	V
	Control Port		-	-	0.2xVLC	V
High-Level Output Voltage at I <sub>o</sub> =2 mA	(Note 28) Serial Port	V <sub>OH</sub>	VLS-1.0	-	-	V
	Control Port		VLC-1.0	-	-	V
	MUTE <sub>C</sub> , GPO <sub>x</sub>		VA-1.0	-	-	V
	TXP		VD-1.0	-	-	V
Low-Level Output Voltage at I <sub>o</sub> =2 mA	(Note 28)	V <sub>OL</sub>	-	-	0.4	V
High-Level Output Voltage at I <sub>o</sub> =100 μA	(Note 28) Serial Port	V <sub>OH</sub>	0.8xVLS	-	-	V
	Control Port		0.8xVLC	-	-	V
	MUTE <sub>C</sub> , GPO <sub>x</sub>		0.8xVA	-	-	V
	TXP		0.8xVD	-	-	V
Low-Level Output Voltage at I <sub>o</sub> =100 μA	(Note 28) Serial Port	V <sub>OL</sub>	-	-	0.2xVLS	V
	Control Port		-	-	0.2xVLC	V
	MUTE <sub>C</sub> , GPO <sub>x</sub>		-	-	0.2xVA	V
	TXP		-	-	0.2xVD	V
Input Sensitivity, RXP[7:0]	V <sub>TH</sub>	-	150	200	mVpp	
Input Leakage Current	I <sub>in</sub>	-	-	±10	μA	
Input Capacitance		-	8	-	pF	
MUTE <sub>C</sub> Drive Current		-	3	-	mA	

**Notes:**

27. Serial Port signals include: RMCK, OMCK, SAI\_SCLK, SAI\_LRCK, SAI\_SDOUT, CX\_SCLK, CX\_LRCK, CX\_SDOUT, CX\_SDIN1-3, AD-CIN1/2
- Port signals include: SCL/CCLK, SDA/CDO<sub>UT</sub>, AD0/ $\overline{\text{CS}}$ , AD1/CDIN, INT,  $\overline{\text{RST}}$  Control S/PDIF-
- GPO Interface signals include: RXP0, RXP/GPO[1:7]
28. When operating RMCK above 24.576 MHz, limit the loading on the signal to 1 CMOS load.

## 2. PIN DESCRIPTIONS



Pin Name	#	Pin Description
CX_SDIN1	1	
CX_SDIN2	64	<b>Codec Serial Audio Data Input (Input)</b> - Input for two's complement serial audio data.
CX_SDIN3	63	
CX_SCLK	2	<b>CODEC Serial Clock (Input/Output)</b> - Serial clock for the CODEC serial audio interface.
CX_LRCK	3	<b>CODEC Left Right Clock (Input/Output)</b> - Determines which channel, Left or Right, is currently active on the CODEC serial audio data line.
VD	4 51	<b>Digital Power (Input)</b> - Positive power supply for the digital section.
DGND	5 52	<b>Digital Ground (Input)</b> - Ground reference. Should be connected to digital ground.
VLC	6	<b>Control Port Power (Input)</b> - Determines the required signal level for the control port.
SCL/CCLK	7	<b>Serial Control Port Clock (Input)</b> - Serial clock for the serial control port. Requires an external pull-up resistor to the logic interface voltage in I <sup>2</sup> C mode as shown in the Typical Connection Diagram.
SDA/CDOUT	8	<b>Serial Control Data (Input/Output)</b> - SDA is a data I/O line in I <sup>2</sup> C mode and requires an external pull-up resistor to the logic interface voltage, as shown in the Typical Connection Diagram. CDOUT is the output data line for the control port interface in SPI mode.
AD1/CDIN	9	<b>Address Bit 1 (I<sup>2</sup>C)/Serial Control Data (SPI) (Input)</b> - AD1 is a chip address pin in I <sup>2</sup> C mode; CDIN is the input data line for the control port interface in SPI mode.
AD0/ $\overline{\text{CS}}$	10	<b>Address Bit 0 (I<sup>2</sup>C)/Control Port Chip Select (SPI) (Input)</b> - AD0 is a chip address pin in I <sup>2</sup> C mode; $\overline{\text{CS}}$ is the chip select signal in SPI mode.



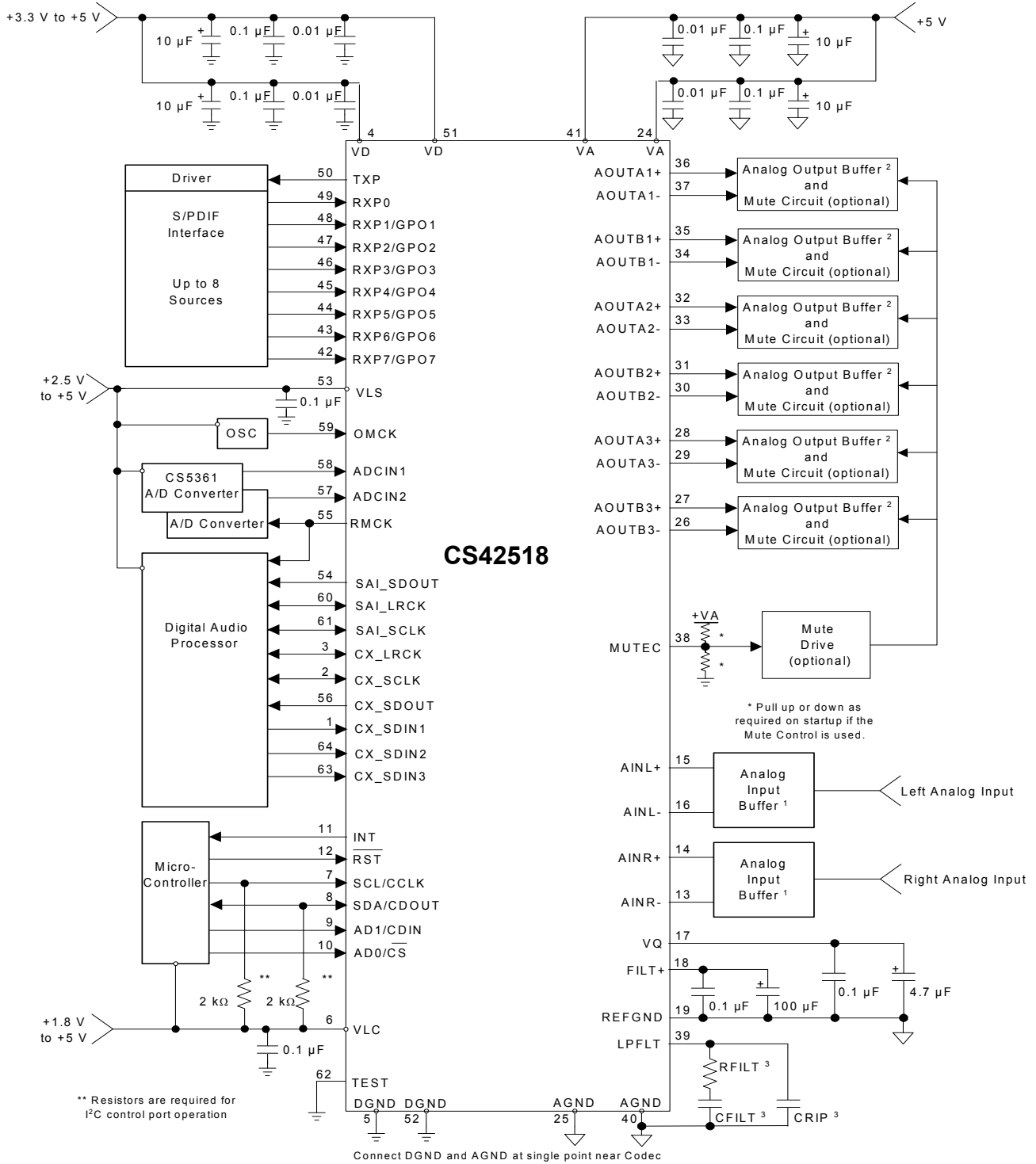
INT	11	<b>Interrupt (Output)</b> - The CS42526 will generate an interrupt condition as per the Interrupt Mask register. See “Interrupts” on page 39 for more details.
$\overline{\text{RST}}$	12	<b>Reset (Input)</b> - The device enters a low power mode and all internal registers are reset to their default settings when low.
AINR- AINR+	13 14	<b>Differential Right Channel Analog Input (Input)</b> - Signals are presented differentially to the delta-sigma modulators via the AINR+/- pins.
AINL+ AINL-	15 16	<b>Differential Left Channel Analog Input (Input)</b> - Signals are presented differentially to the delta-sigma modulators via the AINL+/- pins.
VQ	17	<b>Quiescent Voltage (Output)</b> - Filter connection for internal quiescent reference voltage.
FILT+	18	<b>Positive Voltage Reference (Output)</b> - Positive reference voltage for the internal sampling circuits.
REFGND	19	<b>Reference Ground (Input)</b> - Ground reference for the internal sampling circuits.
	20	
NC	21 22 23	<b>No Connect Pins</b> - Do not make any connection to these pins.
AOUTA1 +,- AOUTB1 +,-	36,37 35,34	
AOUTA2 +,- AOUTB2 +,-	32,33 31,30	<b>Differential Analog Output (Output)</b> - The full-scale differential analog output level is specified in the Analog Characteristics specification table.
AOUTA3 +,- AOUTB3 +,-	28,29 27,26	
VA VARX	24 41	<b>Analog Power (Input)</b> - Positive power supply for the analog section.
AGND	25 40	<b>Analog Ground (Input)</b> - Ground reference. Should be connected to analog ground.
MUTE $\overline{\text{C}}$	38	<b>Mute Control (Output)</b> - The Mute Control pin outputs high impedance following an initial power-on condition or whenever the PDN bit is set to a ‘1’, forcing the codec into power-down mode. The signal will remain in a high impedance state as long as the part is in power-down mode. The Mute Control pin goes to the selected “active” state during reset, muting, or if the master clock to left/right clock frequency ratio is incorrect. This pin is intended to be used as a control for external mute circuits to prevent the clicks and pops that can occur in any single supply system. The use of external mute circuits are not mandatory but may be desired for designs requiring the absolute minimum in extraneous clicks and pops.
LPFLT	39	<b>PLL Loop Filter (Output)</b> - An RC network should be connected between this pin and ground.
RXP7/GPO7 RXP6/GPO6 RXP5/GPO5 RXP4/GPO4 RXP3/GPO3 RXP2/GPO2 RXP1/GPO1	42 43 44 45 46 47 48	<b>S/PDIF Receiver Input/ General Purpose Output (Input/Output)</b> - Receiver inputs for S/PDIF encoded data. The CS42526 has an internal 8:2 multiplexer to select the active receiver port, according to the Receiver Mode Control 2 register. These pins can also be configured as general purpose output pins, ADC Overflow indicators or Mute Control outputs according to the RXP/General Purpose Pin Control registers.
RXP0	49	<b>S/PDIF Receiver Input (Input)</b> - Dedicated receiver input for S/PDIF encoded data.
TXP	50	<b>S/PDIF Transmitter Output (Output)</b> - S/PDIF encoded data output, mapped directly from one of the receiver inputs as indicated by the Receiver Mode Control 2 register.
VLS	53	<b>Serial Port Interface Power (Input)</b> - Determines the required signal level for the serial port interfaces.
SAI_SDO $\overline{\text{U}}$ T	54	<b>Serial Audio Interface Serial Data Output (Output)</b> - Output for two’s complement serial audio PCM data from the S/PDIF incoming stream. This pin can also be configured to transmit the output of the internal and external ADCs.
RMCK	55	<b>Recovered Master Clock (Output)</b> - Recovered master clock output from the External Clock Reference (OMCK, pin 59) or the PLL which is locked to the incoming S/PDIF stream or CX_LRCK.
CX_SDO $\overline{\text{U}}$ T	56	<b>CODEC Serial Data Output (Output)</b> - Output for two’s complement serial audio data from the internal and external ADCs.

---

ADCIN1	58	<b>External ADC Serial Input (Input)</b> - The CS42526 provides for up to two external stereo analog to digital converter inputs to provide a maximum of six channels on one serial data output line when the CS42526 is placed in One-Line Mode.
ADCIN2	57	
OMCK	59	<b>External Reference Clock (Input)</b> - External clock reference that must be within the ranges specified in the register " <a href="#">OMCK Frequency (OMCK Freqx)</a> " on page 52.
TEST	62	<b>Test Pin (Input)</b> - This pin must be connected to DGND.
SAI_LRCK	60	<b>Serial Audio Interface Left/Right Clock (Input/Output)</b> - Determines which channel, Left or Right, is currently active on the serial audio data line.
SAI_SCLK	61	<b>Serial Audio Interface Serial Clock (Input/Output)</b> - Serial clock for the Serial Audio Interface.

---

### 3. TYPICAL CONNECTION DIAGRAM



1. See the ADC Input Filter section in the Appendix.
2. See the DAC Output Filter section in the Appendix.
3. See the PLL Filter section in the Appendix.

Figure 5. Typical Connection Diagram

## 4. APPLICATIONS

### 4.1 Overview

The CS42526 is a highly integrated mixed-signal 24-bit audio codec comprised of 2 analog-to-digital converters (ADC), implemented using multi-bit delta-sigma techniques, 6 digital-to-analog converters (DAC) and a 192 kHz digital audio S/PDIF receiver. Other functions integrated within the codec include independent digital volume controls for each DAC, digital de-emphasis filters for DAC and S/PDIF, digital gain control for ADC channels, ADC high-pass filters, an on-chip voltage reference, and an 8:2 mux for S/PDIF sources. All serial data is transmitted through two configurable serial audio interfaces with standard serial interface support as well as enhanced one-line modes of operation, allowing up to 6 channels of serial audio data on one data line. All functions are configured through a serial control port operable in SPI mode or in I<sup>2</sup>C mode. 5 show the recommended connections for the CS42526.

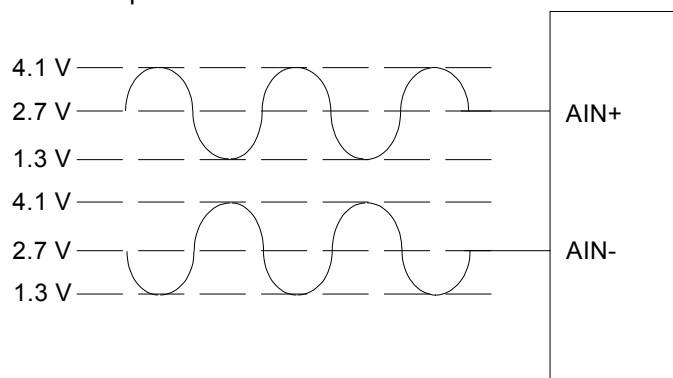
The CS42526 operates in one of three oversampling modes based on the input sample rate. Mode selection is determined by the FM bits in register “[Functional Mode \(address 03h\)](#)” on page 47. Single-Speed Mode (SSM) supports input sample rates up to 50 kHz and uses a 128x oversampling ratio. Double-Speed Mode (DSM) supports input sample rates up to 100 kHz and uses an oversampling ratio of 64x. Quad-Speed Mode (QSM) supports input sample rates up to 192 kHz and uses an oversampling ratio of 32x.

Using the receiver clock recovery PLL, a low-jitter clock is recovered from the incoming S/PDIF data stream. The recovered clock or an externally supplied clock attached to the OMCK pin can be used as the System Clock.

### 4.2 Analog Inputs

#### 4.2.1 Line-Level Inputs

AINR+, AINR-, AINL+, and AINL- are the line-level differential analog inputs. The analog signal must be externally biased to V<sub>Q</sub>, approximately 2.7 V, before being applied to these inputs. The level of the signal can be adjusted for the left and right ADC independently through the ADC Left and Right Channel Gain Control Registers on page 61. The ADC output data is in two’s complement binary format. For inputs above positive full scale or below negative full scale, the ADC will output 7FFFFFFH or 800000H, respectively and cause the ADC Overflow bit in the register “[Interrupt Status \(address 20h\) \(Read Only\)](#)” on page 63 to be set to a ‘1’. The RXP/GPO pins may also be configured to indicate an overflow condition has occurred in the ADC. See “[RXP/General-Purpose Pin Control \(addresses 29h to 2Fh\)](#)” on page 69 for proper configuration. Figure 6 shows the full-scale analog input levels. See “[ADC Input Filter](#)” on page 73 for a recommended input buffer.



Full-Scale Input Level= (AIN+) - (AIN-)= 5.6 Vpp

**Figure 6. Full-Scale Analog Input**

### 4.2.2 High-Pass Filter and DC Offset Calibration

The high-pass filter continuously subtracts a measure of the DC offset from the output of the decimation filter. The high-pass filter can be independently enabled and disabled. If the HPF\_Freeze bit is set during normal operation, the current value of the DC offset for the corresponding channel is frozen and this DC offset will continue to be subtracted from the conversion result. This feature makes it possible to perform a system DC offset calibration by:

1. Running the CS42526 with the high-pass filter enabled until the filter settles. See the Digital Filter Characteristics for filter settling time.
2. Disabling the high-pass filter and freezing the stored DC offset.

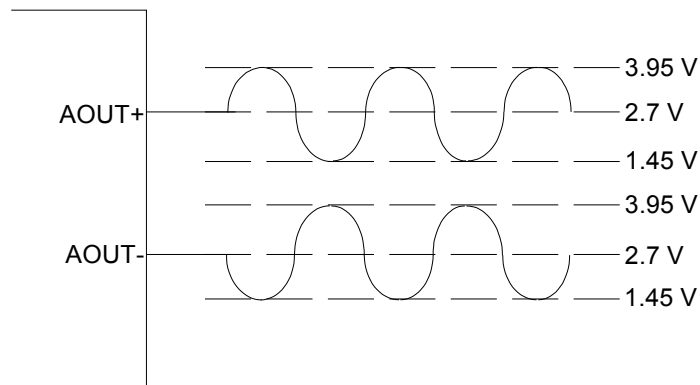
The high-pass filters are controlled using the HPF\_FREEZE bit in the register “Misc Control (address 05h)” on page 50.

## 4.3 Analog Outputs

### 4.3.1 Line-Level Outputs and Filtering

The CS42526 contains on-chip buffer amplifiers capable of producing line-level differential outputs. These amplifiers are biased to a quiescent DC level of approximately V<sub>Q</sub>.

The delta-sigma conversion process produces high-frequency noise beyond the audio passband, most of which is removed by the on-chip analog filters. The remaining out-of-band noise can be attenuated using an off-chip low-pass filter. See “DAC Output Filter” on page 73 for a recommended output buffer. This filter configuration accounts for the normally differing AC loads on the AOUT+ and AOUT- differential output pins. It also shows an AC coupling configuration which minimizes the number of required AC coupling capacitors. Figure 7 shows the full-scale analog output levels.



Full-Scale Output Level = (A<sub>IN+</sub>) - (A<sub>IN-</sub>) = 5 V<sub>pp</sub>

**Figure 7. Full-Scale Output**

### 4.3.2 Interpolation Filter

To accommodate the increasingly complex requirements of digital audio systems, the CS42526 incorporates selectable interpolation filters for each mode of operation. A “fast” and a “slow” roll-off filter is available in Single-, Double-, and Quad-Speed Modes. These filters have been designed to accommodate a variety of musical tastes and styles. The FILT\_SEL bit found in the register “Misc Control (address 05h)” on page 50 selects which filter is used. Filter response plots can be found in Figures 46 to 69.

### 4.3.3 Digital Volume and Mute Control

Each DAC's output level is controlled via the Volume Control registers operating over the range of 0 to -127 dB attenuation with 0.5 dB resolution. See [“Volume Control \(addresses 0Fh, 10h, 11h, 12h, 13h, 14h\)” on page 58](#). Volume control changes are programmable to ramp in increments of 0.125 dB at the rate controlled by the SZC[1:0] bits in the Digital Volume Control register. See [“Volume Transition Control \(address 0Dh\)” on page 56](#).

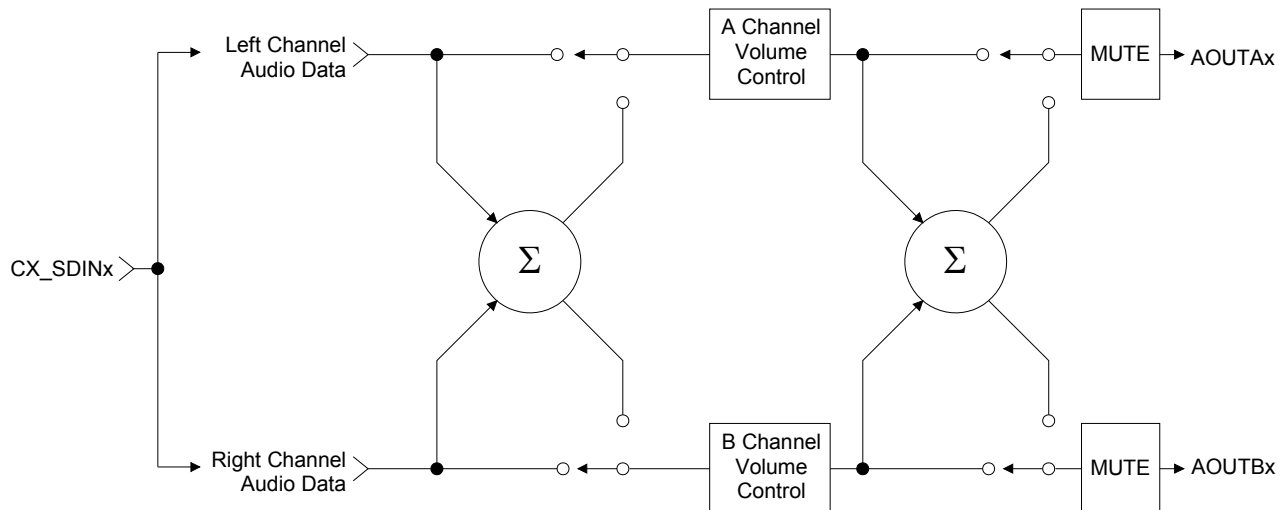
Each output can be independently muted via mute control bits in the register [“Channel Mute \(address 0Eh\)” on page 58](#). When enabled, each XX\_MUTE bit attenuates the corresponding DAC to its maximum value (-127 dB). When the XX\_MUTE bit is disabled, the corresponding DAC returns to the attenuation level set in the Volume Control register. The attenuation is ramped up and down at the rate specified by the SZC[1:0] bits.

The Mute Control pin, MUTE<sub>EC</sub>, is typically connected to an external mute control circuit. The Mute Control pin outputs high impedance during Power-Up or in Power-Down Mode by setting the PDN bit in the register [“Power Control \(address 02h\)” on page 46](#) to a ‘1’. Once out of Power-Down Mode, the pin can be controlled by the user via the control port, or automatically asserted high when zero data is present on all DAC inputs, or when serial port clock errors are present. To prevent large transients on the output, it is desirable to mute the DAC outputs before the Mute Control pin is asserted. Please see the MUTE<sub>EC</sub> pin in the Pin Descriptions section for more information.

Each of the RXP1/GPO1-RXP7/GPO7 can be programmed to provide a hardware MUTE signal to individual circuits. When not used as an S/PDIF input, each pin can be programmed as an output, with specific muting capabilities as defined by the function bits in the register [“RXP/General-Purpose Pin Control \(addresses 29h to 2Fh\)” on page 69](#).

### 4.3.4 ATAPI Specification

The CS42526 implements the channel-mixing functions of the ATAPI CD-ROM specification. The ATAPI functions are applied per A-B pair. Refer to [Table 16 on page 60](#) and [Figure 8](#) for additional information.



**Figure 8. ATAPI Block Diagram (x = channel pair 1, 2, or 3)**

## 4.4 S/PDIF Receiver

The CS42526 includes an S/PDIF digital audio receiver. The S/PDIF receiver accepts and decodes digital audio data according to the IEC60958 (S/PDIF), and EIAJ CP-1201 interface standards. The receiver consists of an 8:2 multiplexer input stage driven through pins RXP0 and RXP1/GPO1 - RXP7/GPO7, a PLL based clock recovery circuit, and a decoder which separates the audio data from the channel status and user data. A comprehensive buffering scheme provides read access to the channel status and user data.

External components are used to terminate and isolate the incoming data cables from the CS42526. These components and required circuitry are detailed in the CDB42528.

### 4.4.1 8:2 S/PDIF Input Multiplexer

The CS42526 contains an 8:2 S/PDIF Input Multiplexer to accommodate up to eight channels of input digital audio data. Digital audio data is single-ended and input through the RXP0 and RXP1/GPO1-RXP7/GPO7 pins. Any one of these inputs can be multiplexed to the input of the S/PDIF receiver and to the S/PDIF output pin TXP.

When any portion of the multiplexer is implemented, unused RXP0 and RXPx/GPOx pins should be tied to a 0.01uF capacitor to ground. The receiver multiplexer select line control is accessed through bits RMUX2:0 in the Receiver Mode Control 2 register on [page 63](#). The TXP multiplexer select line control is accessed through bits TMUX2:0 in the same register. The multiplexer defaults to RXP0 for both functions.

### 4.4.2 Error Reporting and Hold Function

While decoding the incoming S/PDIF data stream, the CS42526 can identify several kinds of error, indicated in the register “[Receiver Errors \(address 26h\) \(Read Only\)](#)” on [page 67](#). See “[Error Reporting and Hold Function](#)” on [page 74](#) for more information.

### 4.4.3 Channel Status Data Handling

The first 2 bytes of the Channel Status block (C data) are decoded into the Receiver Channel Status register (See “[Receiver Channel Status \(address 25h\) \(Read Only\)](#)” on [page 66](#)). See “[Channel Status Data Handling](#)” on [page 74](#) for more information.

### 4.4.4 User Data Handling

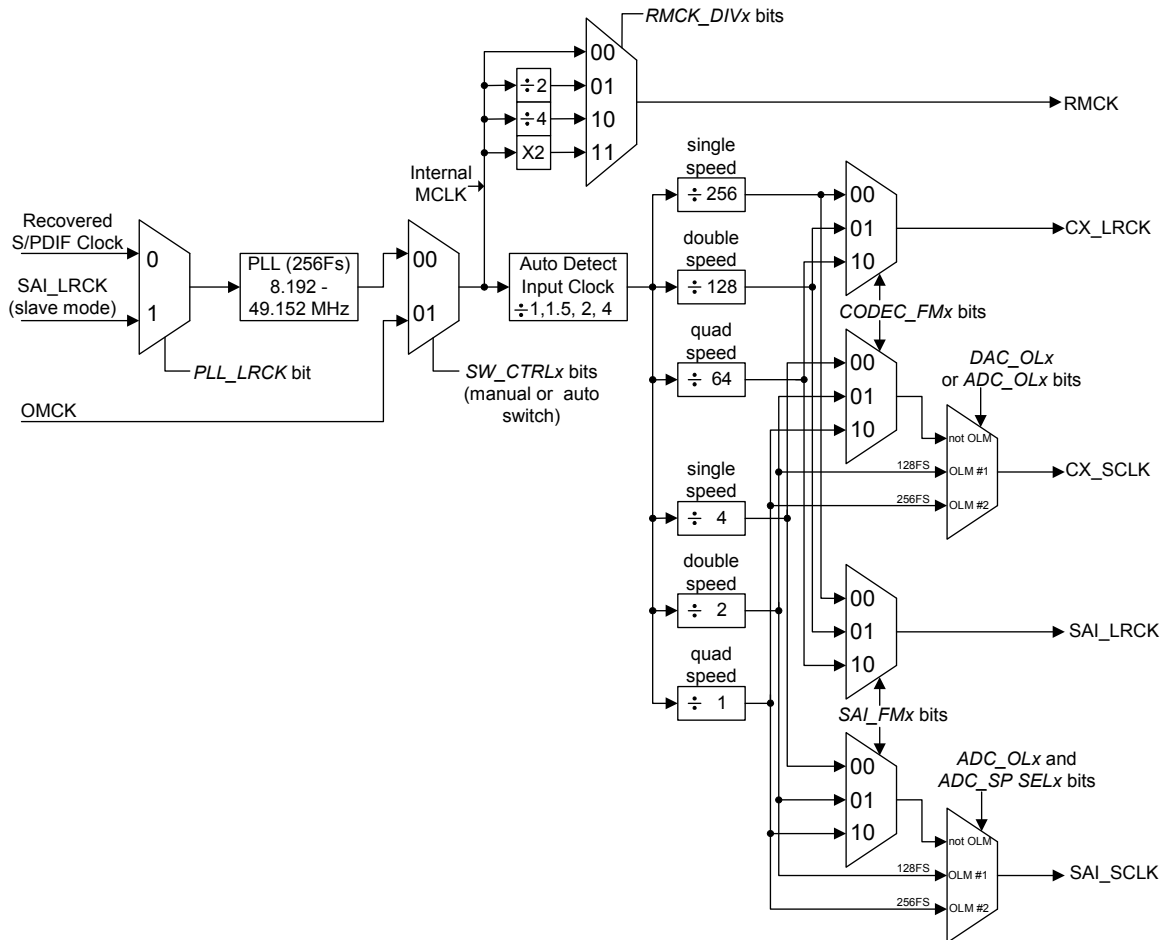
The incoming User (U) data is buffered in a user accessible buffer. If the U data bits have been encoded as Q-channel subcode, the data is decoded and presented in 10 consecutive register locations, address 30h to 39h. The user can configure the Interrupt Mask Register to cause interrupts to indicate the decoding of a new Q-channel block, which may be read through the control port. See “[User \(U\) Data E Buffer Access](#)” on [page 76](#) for more information.

### 4.4.5 Non-Audio Auto-Detection

A S/PDIF data stream may be used to convey non-audio data, thus it is important to know whether the incoming data stream is digital PCM audio samples or not. This information is typically conveyed in channel status bit 1 (AUDIO), which is extracted automatically by the CS42526. Certain non-audio sources, however, such as AC-3® or MPEG encoders, may not adhere to this convention, and the bit may not be properly set. See “[Non-Audio Auto-Detection](#)” on [page 76](#) for more information including details for interface format detection.

## 4.5 Clock Generation

The clock generation for the CS42526 is shown in the figure below. The internal MCLK is derived from the output of the PLL or a master clock source attached to OMCK. The mux selection is controlled by the SW\_CTRLx bits and can be configured to manual switch mode only, or automatically switch on loss of PLL lock to the other source input.



**Figure 9. CS42526 Clock Generation**

### 4.5.1 PLL and Jitter Attenuation

An on-chip Phase Locked Loop (PLL) is used to recover the clock from the incoming S/PDIF data stream. There are some applications where low jitter in the recovered clock, presented on the RMCK pin, is important. For this reason, the PLL has been designed to have good jitter attenuation characteristics as shown in Figure 28 on page 79.

The PLL can be configured to lock onto the incoming SAI\_LRCK signal from the Serial Audio Interface Port and generate the required internal master clock frequency. By setting the PLL\_LRCK bit to a '1' in the register [“Clock Control \(address 06h\)” on page 52](#), the PLL will lock to the incoming SAI\_LRCK and generate an output master clock (RMCK) of 256Fs. [Table 2](#) shows the output of the PLL with typical input Fs values for SAI\_LRCK.

See [“Appendix C: PLL Filter” on page 77](#) for more information concerning PLL operation, required filter components, optimal layout guidelines, and jitter-attenuation characteristics.



### 4.5.2 OMCK System Clock Mode

A special clock-switching mode is available that allows the clock that is input through the OMCK pin to be used as the internal master clock. This feature is controlled by the SW\_CTRLx bits in register “[Clock Control \(address 06h\)](#)” on page 52. An advanced auto-switching mode is also implemented to maintain master clock functionality. The clock auto-switching mode allows the clock input through OMCK to be used as a clock in the system without any disruption when the PLL loses lock, for example, when the input is removed from the receiver. This clock-switching is done glitch-free. A clock adhering to the specifications detailed in the Switching Characteristics table on page 11 must be applied to the OMCK pin at all times that the FRC\_PLL\_LK bit is set to ‘0’ (See “[Force PLL Lock \(FRC\\_PLL\\_LK\)](#)” on page 53).

Sample Rate (kHz)	OMCK (MHz)								
	Single-Speed (4 to 50 kHz)			Double-Speed (50 to 100 kHz)			Quad-Speed (100 to 192 kHz)		
	256x	384x	512x	128x	192x	256x	64x	96x	128x
48	12.2880	18.4320	24.5760	-	-	-	-	-	-
96	-	-	-	12.2880	18.4320	24.5760	-	-	-
192	-	-	-	-	-	-	12.2880	18.4320	24.5760

Table 1. Common OMCK Clock Frequencies

### 4.5.3 Master Mode

In Master Mode, the serial interface timings are derived from an external clock attached to OMCK or from the output of the PLL with an input reference to either the S/PDIF Receiver recovered clock or the SAI\_LRCK input from the Serial Audio Interface Port. Master clock selection and operation is configured with the SW\_CTRL1:0 bits in the Clock Control Register (See “[Clock Control \(address 06h\)](#)” on page 52). The supported PLL output frequencies are shown in Table 2 below.

Sample Rate (kHz)	PLL Output (MHz)		
	Single Speed (4 to 50 kHz)	Double Speed (50 to 100 kHz)	Quad Speed (100 to 192 kHz)
	256x	256x	256x
32	8.1920	-	-
44.1	11.2896	-	-
48	12.2880	-	-
64	-	16.3840	-
88.2	-	22.5792	-
96	-	24.5760	-
176.4	-	-	45.1584
192	-	-	49.1520

Table 2. Common PLL Output Clock Frequencies

### 4.5.4 Slave Mode

In Slave Mode, CX\_LRCK, CX\_SCLK and/or SAI\_LRCK, SAI\_SCLK operate as inputs. The Left/Right clock signal must be equal to the sample rate, Fs, and must be synchronously derived from the supplied master clock, OMCK, or the output of the PLL. The serial bit clock, CX\_SCLK and/or SAI\_SCLK, must be synchronously derived from the master clock and be equal to 128x, 64x, 48x or 32x Fs, depending on the interface format selected and desired speed mode.

When the device is clocked from OMCK, the frequency of OMCK must be at least twice the frequency of the fastest Slave Mode, SCLK. For example, if both serial ports are in Slave Mode with one SCLK running at 32x Fs and the other at 64x Fs, the slowest OMCK signal that can be used to clock the device is 128x Fs.

When either serial port is in Slave Mode, its respective LRCK signal must be present for proper device operation.

In Slave Mode, One-Line Mode #1 is supported; One-Line Mode #2 is not.

The sample rate to OMCK ratios and OMCK frequency requirements for Slave Mode operation are shown in [Table 1](#). Refer to [Table 3](#) for required clock ratios.

	Single-Speed	Double-Speed	Quad-Speed	One-Line Mode #1
OMCK/LRCK Ratio	256x, 384x, 512x	128x, 192x, 256x	64x, 96x, 128x	256x
SCLK/LRCK Ratio	32x, 48x, 64x, 128x	32x, 48x, 64x	32x, 48x, 64x	128x

**Table 3. Slave Mode Clock Ratios**

## 4.6 Digital Interfaces

### 4.6.1 Serial Audio Interface Signals

The CS42526 interfaces to an external Digital Audio Processor via two independent serial ports, the CODEC serial port, CODEC\_SP and the Serial Audio Interface serial port, SAI\_SP. The digital output of the internal ADCs can be configured to use either the CX\_SDOUT pin or the SAI\_SDOUT pin and the corresponding serial port clocking signals. These configuration bits and the selection of Single-, Double- or Quad-Speed Mode for CODEC\_SP and SAI\_SP are found in register [“Functional Mode \(address 03h\)”](#) on [page 47](#).

The serial interface clocks, SAI\_SCLK for SAI\_SP and CX\_SCLK for CODEC\_SP, are used for transmitting and receiving audio data. Either SAI\_SCLK or CX\_SCLK can be generated by the CS42526 (Master Mode), or it can be input from an external source (Slave Mode). Master or Slave Mode selection is made using bits CODEC\_SP M/S and SAI\_SP M/S in register [“Misc Control \(address 05h\)”](#) on [page 50](#).

The Left/Right clock (SAI\_LRCK or CX\_LRCK) is used to indicate left and right data frames and the start of a new sample period. It may be an output of the CS42526 (Master Mode), or it may be generated by an external source (Slave Mode). As described in later sections, particular modes of operation do allow the sample rate,  $F_s$ , of the SAI\_SP and the CODEC\_SP to be different, but must be multiples of each other.

The serial data interface format selection (Left/Right-Justified, I<sup>2</sup>S or One-Line Mode) for the Serial Audio Interface serial port data out pin, SAI\_SDOUT, the CODEC serial port data out pin, CX\_SDOUT, and the CODEC input pins, CX\_SDIN1:3, is configured using the appropriate bits in the register [“Interface Formats \(address 04h\)”](#) on [page 49](#). The serial audio data is presented in two's complement binary form with the MSB first in all formats.

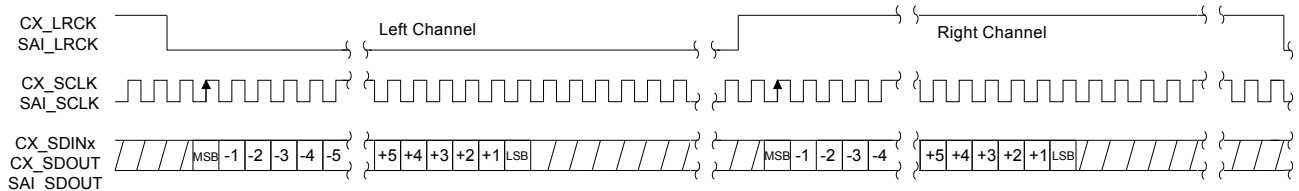
CX\_SDIN1, CX\_SDIN2, and CX\_SDIN3 are the serial data input pins supplying the associated internal DAC. CX\_SDOUT, the ADC data output pin, carries data from the two internal 24-bit ADCs and, when configured for one-line mode, up to four additional ADC channels attached externally to the signals ADCIN1 and ADCIN2 (typically two CS5361 stereo ADCs). When operated in One-Line Mode, 6 channels of DAC data are input on CX\_SDIN1 and 6 channels of ADC data are output on CX\_SDOUT. [Table 4](#) on [page 27](#) outlines the serial port channel allocations.

<b>Serial Inputs / Outputs</b>		
CX_SDIN1	left channel right channel One-Line Mode	DAC #1 DAC #2 DAC channels 1,2,3,4,5,6
CX_SDIN2	left channel right channel One-Line Mode	DAC #3 DAC #4 not used
CX_SDIN3	left channel right channel One-Line Mode	DAC #5 DAC #6 not used
CX_SDOUT	left channel right channel One-Line Mode	ADC #1 ADC #2 ADC channels 1,2,3,4,5,6
SAI_SDOUT	left channel right channel One-Line Mode	S/PDIF Left or ADC #1 S/PDIF Right or ADC #2 ADC channels 1,2,3,4,5,6
ADCIN1	left channel right channel	External ADC #3 External ADC #4
ADCIN2	left channel right channel	External ADC #5 External ADC #6

**Table 4. Serial Audio Port Channel Allocations**

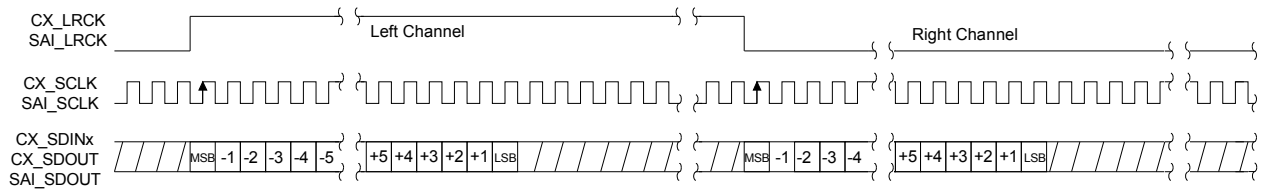
### 4.6.2 Serial Audio Interface Formats

The CODEC\_SP and SAI\_SP digital audio serial ports support five formats with varying bit depths from 16 to 24 as shown in Figures 10 to 14. These formats are selected using the configuration bits in the registers, “Functional Mode (address 03h)” on page 47 and “Interface Formats (address 04h)” on page 49. For the diagrams below, Single-Speed Mode is equivalent to  $F_s = 32, 44.1, 48$  kHz; Double-Speed Mode is for  $F_s = 64, 88.2, 96$  kHz; and Quad-Speed Mode is for  $F_s = 176.4, 196$  kHz.

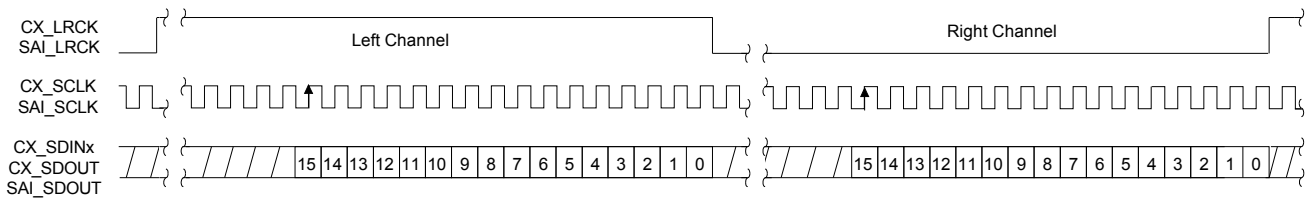


I <sup>2</sup> S Mode, Data Valid on Rising Edge of SCLK			
Bits/Sample	SCLK Rate(s)		Notes
	Master	Slave	
16	64	48, 64, 128 $F_s$	Single-Speed Mode
	64 $F_s$	64 $F_s$	Double-Speed Mode
	64 $F_s$	64 $F_s$	Quad-Speed Mode
18 to 24	64, 128, 256 $F_s$	48, 64, 128 $F_s$	Single-Speed Mode
	64 $F_s$	48, 64 $F_s$	Double-Speed Mode
	64 $F_s$	48, 64 $F_s$	Quad-Speed Mode

Figure 10. I<sup>2</sup>S Serial Audio Formats

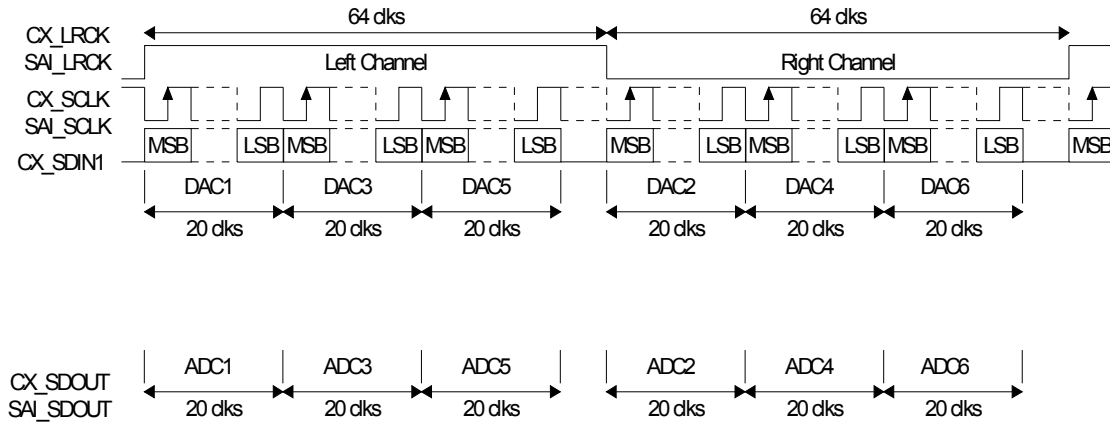


Left-Justified Mode, Data Valid on Rising Edge of SCLK			
Bits/Sample	SCLK Rate(s)		Notes
	Master	Slave	
16	64	32, 48, 64, 128 Fs	Single-Speed Mode
	64 Fs	32, 64 Fs	Double-Speed Mode
	64 Fs	32, 64 Fs	Quad-Speed Mode
18 to 24	64, 128, 256 Fs	48, 64, 128 Fs	Single-Speed Mode
	64 Fs	48, 64 Fs	Double-Speed Mode
	64 Fs	48, 64 Fs	Quad-Speed Mode

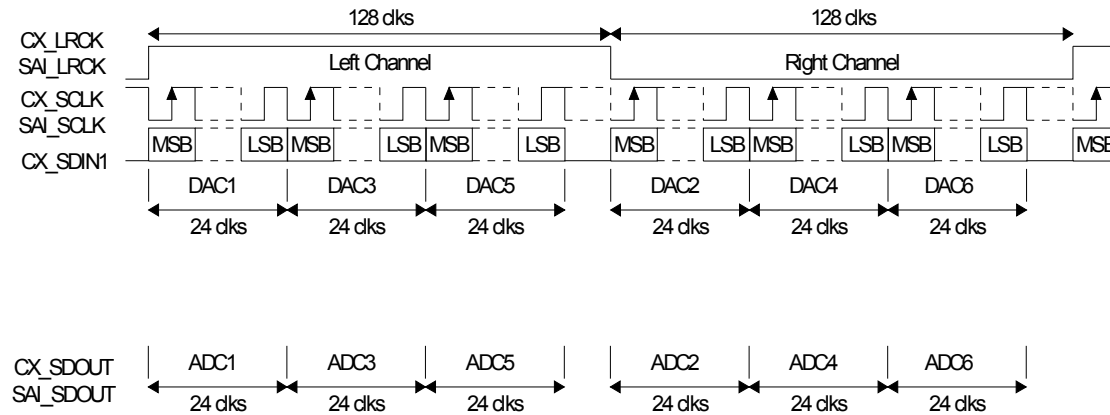
**Figure 11. Left-Justified Serial Audio Formats**


Right-Justified Mode, Data Valid on Rising Edge of SCLK			
Bits/Sample	SCLK Rate(s)		Notes
	Master	Slave	
16	64	32, 48, 64, 128 Fs	Single-Speed Mode
	64 Fs	32, 64 Fs	Double-Speed Mode
	64 Fs	32, 64 Fs	Quad-Speed Mode
24	64, 128, 256 Fs	48, 64, 128 Fs	Single-Speed Mode
	64 Fs	48, 64 Fs	Double-Speed Mode
	64 Fs	48, 64 Fs	Quad-Speed Mode

**Figure 12. Right-Justified Serial Audio Formats**



One Line Data Mode #1, Data Valid on Rising Edge of SCLK			
Bits/Sample	SCLK Rate(s)		Notes
	Master	Slave	
20	128 Fs	128 Fs	single-speed mode
	128 Fs	128 Fs	double-speed mode

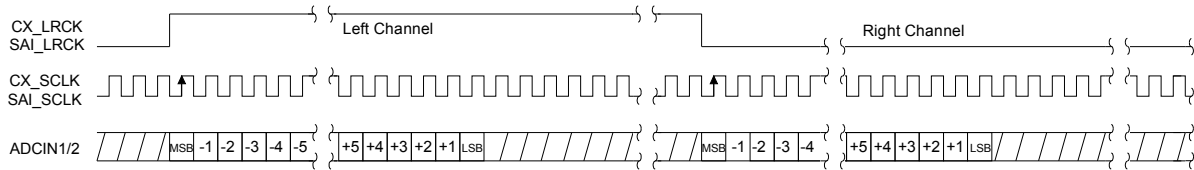
**Figure 13. One Line Mode #1 Serial Audio Format**


One Line Data Mode #2, Data Valid on Rising Edge of SCLK			
Bits/Sample	SCLK Rate(s)		Notes
	Master	Slave	
24	256 Fs	not supported	single-speed mode

**Figure 14. One Line Mode #2 Serial Audio Format**

### 4.6.3 ADCIN1/ADCIN2 Serial Data Format

The two serial data lines which interface to the optional external ADCs, ADCIN1 and ADCIN2, support only left-justified, 24-bit samples at 64Fs or 128Fs. This interface is not affected by any of the serial port configuration register bit settings. These serial data lines are used when supporting One-Line Mode of operation with external ADCs attached. If these signals are not being used, they should be tied together and wired to GND via a pull-down resistor.



Left-Justified Mode, Data Valid on Rising Edge of SCLK		
Bits/Sample	SCLK Rate(s)	Notes
24	64, 128 Fs	Single-Speed Mode, Fs= 32, 44.1, 48 kHz
	64 Fs	Double-Speed Mode, Fs= 64, 88.2, 96 kHz
	not supported	Quad-Speed Mode, Fs= 176.4, 192 kHz

**Figure 15. ADCIN1/ADCIN2 Serial Audio Format**

For proper operation, the CS42526 must be configured to select which SCLK/LRCK is being used to clock the external ADCs. The EXT ADC SCLK bit in register “Misc Control (address 05h)” on page 50 must be set accordingly. Set this bit to ‘1’ if the external ADCs are wired using the CODEC\_SP clocks. If the ADCs are wired to use the SAI\_SP clocks, set this bit to ‘0’.

#### 4.6.4 One-Line Mode (OLM) Configurations

##### 4.6.4.1 OLM Config #1

One-Line Mode Configuration #1 can support up to 6 channels of DAC data, 6 channels of ADC data and 2 channels of S/PDIF received data. This is the only configuration which will support up to 24-bit samples at a sampling frequency of 48 kHz on all channels for both the DAC and ADC.

Register / Bit Settings	Description
<b>Functional Mode Register (addr = 03h)</b>	
Set CODEC_Fm <sub>x</sub> = SAI_FM <sub>x</sub> = 00,01,10	CX_LRCK must equal SAI_LRCK; sample rate conversion not supported
Set ADC_SP SEL <sub>x</sub> = 00	Configure ADC data on CX_SDO <sub>UT</sub> , S/PDIF data on SAI_SDO <sub>UT</sub>
<b>Interface Format Register (addr = 04h)</b>	
Set DIF <sub>x</sub> bits to proper serial format	Select the digital interface format when not in One-Line Mode
Set ADC_OL <sub>x</sub> bits = 00,01,10	Select ADC operating mode, see table below for valid combinations
Set DAC_OL <sub>x</sub> bits = 00,01,10	Select DAC operating mode, see table below for valid combinations
<b>Misc. Control Register (addr = 05h)</b>	
Set CODEC_SP M/S = 1	Configure CODEC Serial Port to master mode.
Set SAI_SP M/S = 1	Configure Serial Audio Interface Port to master mode.
Set EXT ADC SCLK = 0	Identify external ADC clock source as SAI Serial Port.

		DAC Mode		
		Not One-Line Mode	One-Line Mode #1	One-Line Mode #2
ADC Mode	Not One-Line Mode	CX_SCLK=64 Fs CX_LRCK=SSM/DSM/QSM SAI_SCLK=64 Fs SAI_LRCK=CX_LRCK	CX_SCLK=128 Fs CX_LRCK=SSM/DSM SAI_SCLK=64 Fs SAI_LRCK=CX_LRCK	not valid
	One-Line Mode #1	CX_SCLK=128 Fs CX_LRCK=SSM/DSM SAI_SCLK=64 Fs SAI_LRCK=CX_LRCK	CX_SCLK=128 Fs CX_LRCK=SSM/DSM SAI_SCLK=64 Fs SAI_LRCK=CX_LRCK	not valid
	One-Line Mode #2	CX_SCLK=256 Fs CX_LRCK=SSM SAI_SCLK=64 Fs SAI_LRCK=CX_LRCK	not valid	CX_SCLK=256 Fs CX_LRCK=SSM SAI_SCLK=64 Fs SAI_LRCK=CX_LRCK

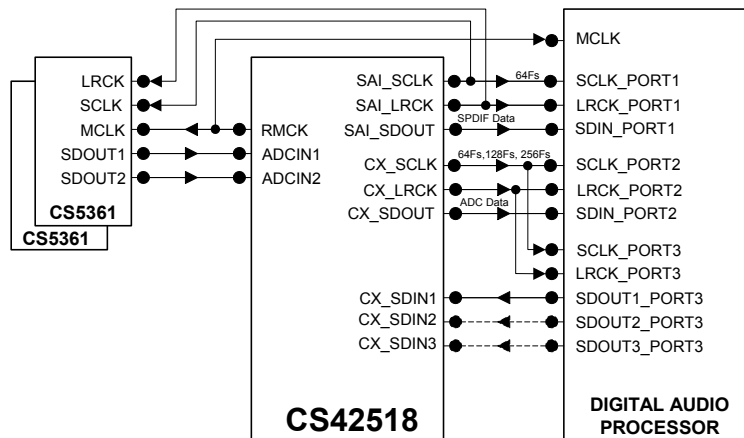


Figure 16. OLM Configuration #1



### 4.6.4.2 OLM Config #2

This configuration will support up to 6 channels of DAC data or 6 channels of ADC data and no channels of S/PDIF received data and will handle up to 20-bit samples at a sampling-frequency of 96 kHz on all channels for both the DAC and ADC. The output data stream of the internal and external ADCs is configured to use the SAI\_SDOUT output and run at the SAI\_SP clock speeds.

Register / Bit Settings	Description
<b>Functional Mode Register (addr = 03h)</b>	
Set CODEC_Fm <sub>x</sub> = SAI_Fm <sub>x</sub> = 00,01,10	CX_LRCK must equal SAI_LRCK; sample rate conversion not supported
Set ADC_SP SEL <sub>x</sub> = 10	Configure ADC data to use SAI_SDOUT and SAI_SP Clocks. S/PDIF data is not supported in this configuration
<b>Interface Format Register (addr = 04h)</b>	
Set DIF <sub>x</sub> bits to proper serial format	Select the digital interface format when not in one line mode
Set ADC_OL <sub>x</sub> bits = 00,01,10	Select ADC operating mode, see table below for valid combinations
Set DAC_OL <sub>x</sub> bits = 00,01	Select DAC operating mode, see table below for valid combinations
<b>Misc. Control Register (addr = 05h)</b>	
Set CODEC_SP M/S = 1	Set CODEC Serial Port to master mode.
Set SAI_SP M/S = 1	Set Serial Audio Interface Port to master mode.
Set EXT ADC SCLK = 1	Identify external ADC clock source as CODEC Serial Port.

CX_SDOUT= not used SAI_SDOUT=ADC Data		DAC Mode		
		Not One-Line Mode	One-Line Mode #1	One-Line Mode #2
ADC Mode	Not One-Line Mode	CX_SCLK=64 Fs CX_LRCK=SSM/DSM/QSM SAI_SCLK=64 Fs SAI_LRCK=CX_LRCK	CX_SCLK=128 Fs CX_LRCK=SSM SAI_SCLK=64 Fs SAI_LRCK=CX_LRCK	not valid
	One-Line Mode #1	CX_SCLK=64 Fs CX_LRCK=SSM/DSM SAI_SCLK=128 Fs SAI_LRCK=CX_LRCK	CX_SCLK=128 Fs CX_LRCK=SSM SAI_SCLK=128 Fs SAI_LRCK=CX_LRCK	not valid
	One-Line Mode #2	CX_SCLK=64 Fs CX_LRCK=SSM SAI_SCLK=256 Fs SAI_LRCK=CX_LRCK	not valid	not valid

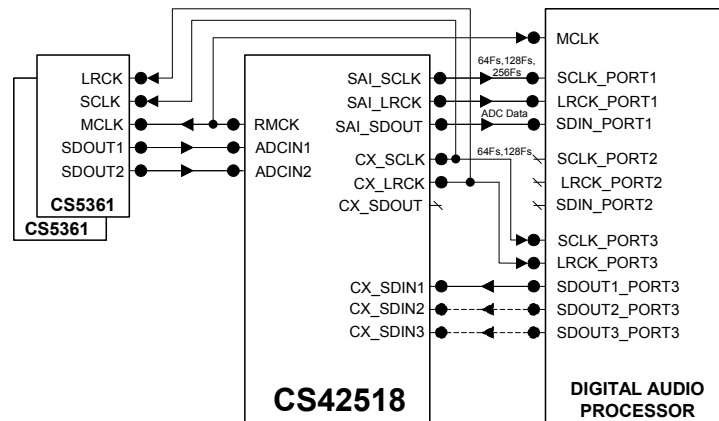


Figure 17. OLM Configuration #2

### 4.6.4.3 OLM Config #3

This One Line Mode configuration #3 will support up to 6 channels of DAC data, 6 channels of ADC data and 2 channels of S/PDIF received data and will handle up to 20-bit samples at a sampling frequency of 48kHz on all channels for both the DAC and ADC. The output data stream of the internal and external ADCs is configured to use the CX\_SDOUT output and run at the CODEC\_SP clock speeds. One Line Mode #2, which supports 24-bit samples, is not supported by this configuration.

Register / Bit Settings	Description
<b>Functional Mode Register (addr = 03h)</b>	
Set CODEC_Fm <sub>x</sub> = SAI_Fm <sub>x</sub> = 00,01,10	CX_LRCK must equal SAI_LRCK; sample rate conversion not supported
Set ADC_SP SEL <sub>x</sub> = 00	Configure ADC data to use CX_SDOUT and CODEC_SP Clocks. S/PDIF data is supported on SAI_SDOUT
<b>Interface Format Register (addr = 04h)</b>	
Set DIF <sub>x</sub> bits to proper serial format	Select the digital interface format when not in one line mode
Set ADC_OL <sub>x</sub> bits = 00,01	Select ADC operating mode, see table below for valid combinations
Set DAC_OL <sub>x</sub> bits = 00,01	Select DAC operating mode, see table below for valid combinations
<b>Misc. Control Register (addr = 05h)</b>	
Set CODEC_SP M/S = 1	Set CODEC Serial Port to master mode.
Set SAI_SP M/S = 0 or 1	Set Serial Audio Interface Port to master mode or slave mode.
Set EXT ADC SCLK = 1	Identify external ADC clock source as CODEC Serial Port.

CX_SDOUT= ADC Data SAI_SDOUT=S/PDIF Data		DAC Mode		
		Not One Line Mode	One Line Mode #1	One Line Mode #2
ADC Mode	Not One-Line Mode	CX_SCLK=64 Fs CX_LRCK=SSM/DSM/QSM SAI_SCLK=64 Fs SAI_LRCK=CX_LRCK	CX_SCLK=128 Fs CX_LRCK=SSM SAI_SCLK=64 Fs SAI_LRCK=CX_LRCK	not valid
	One-Line Mode #1	CX_SCLK=128 Fs CX_LRCK=SSM SAI_SCLK=64 Fs SAI_LRCK=CX_LRCK	CX_SCLK=128 Fs CX_LRCK=SSM SAI_SCLK=64 Fs SAI_LRCK=CX_LRCK	not valid
	One-Line Mode #2	not valid	not valid	not valid

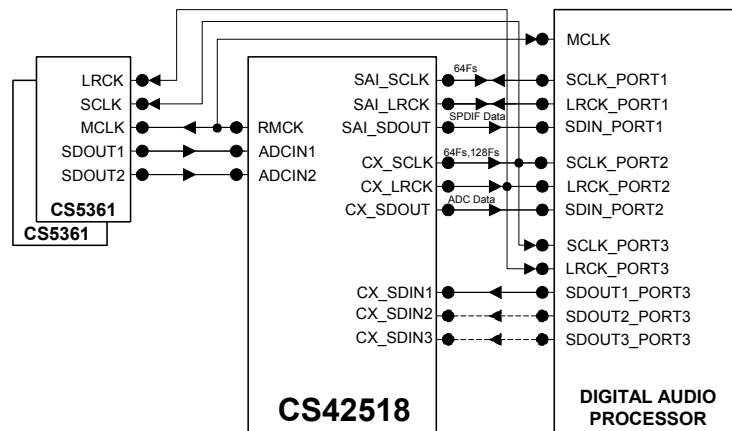


Figure 18. OLM Configuration #3

#### 4.6.4.4 OLM Config #4

This configuration will support up to 6 channels of DAC data 6 channels of ADC data and no channels of S/PDIF received data. OLM Config #4 will handle up to 20-bit ADC samples at an Fs of 48 kHz and 24-bit DAC samples at an Fs of 48 kHz. Since the ADC's data stream is configured to use the SAI\_SDOOUT output and the internal and external ADCs are clocked from the SAI\_SP, the sample rate for the CODEC Serial Port can be different from the sample rate of the Serial Audio Interface serial port.

Register / Bit Settings	Description
<b>Functional Mode Register (addr = 03h)</b>	
Set CODEC_Fm <sub>x</sub> = 00,01,10	CX_LRCK can run at SSM, DSM, or QSM independent of SAI_LRCK
Set SAI_FM <sub>x</sub> = 00,01,10	SAI_LRCK can run at SSM, DSM, or QSM independent of CX_LRCK
Set ADC_SP SEL <sub>x</sub> = 10	Configure ADC data to use SAI_SDOOUT and SAI_SP Clocks. S/PDIF data is not supported in this configuration
<b>Interface Format Register (addr = 04h)</b>	
Set DIF <sub>x</sub> bits to proper serial format	Select the digital interface format when not in one line mode
Set ADC_OL <sub>x</sub> bits = 00,01	Select ADC operating mode, see table below for valid combinations
Set DAC_OL <sub>x</sub> bits = 00,01,10	Select DAC operating mode, see table below for valid combinations
<b>Misc. Control Register (addr = 05h)</b>	
Set CODEC_SP M/S = 1	Set DAC Serial Port to master mode.
Set SAI_SP M/S = 0 or 1	Set ADC Serial Port to master mode or slave mode.
Set EXT ADC SCLK = 0	Identify external ADC clock source as SAI Serial Port.

CX_SDOOUT= not used SAI_SDOOUT=ADC Data		DAC Mode		
		Not One Line Mode	One Line Mode #1	One Line Mode #2
ADC Mode	Not One-Line Mode	CX_SCLK=64 Fs CX_LRCK=SSM/DSM/QSM SAI_SCLK=64 Fs SAI_LRCK=SSM/DSM/QSM	CX_SCLK=128 Fs CX_LRCK=SSM/DSM SAI_SCLK=64 Fs SAI_LRCK=SSM/DSM/QSM	CX_SCLK=256 Fs CX_LRCK=SSM SAI_SCLK=64 Fs SAI_LRCK=SSM/DSM/QSM
	One-Line Mode #1	CX_SCLK=64 Fs CX_LRCK=SSM/DSM/QSM SAI_SCLK=128 Fs SAI_LRCK=SSM	CX_SCLK=128 Fs CX_LRCK=SSM/DSM SAI_SCLK=128 Fs SAI_LRCK=SSM	CX_SCLK=256 Fs CX_LRCK=SSM SAI_SCLK=128 Fs SAI_LRCK=SSM
	One-Line Mode #2	not valid	not valid	not valid

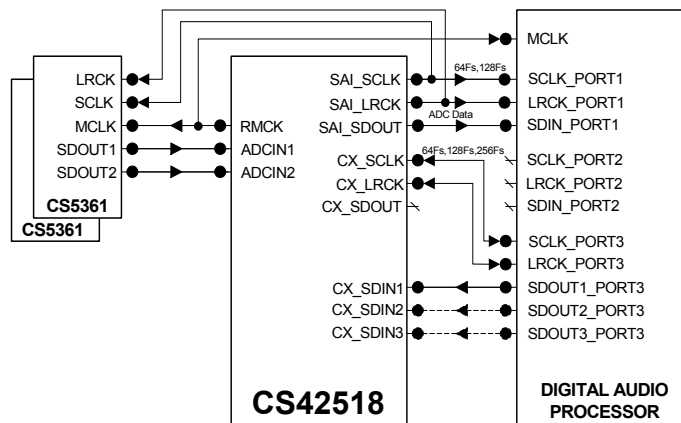


Figure 19. OLM Configuration #4

#### 4.6.4.5 OLM Config #5

This One-Line Mode configuration can support up to 6 channels of DAC data 2 channels of ADC data and 2 channels of S/PDIF received data and will handle up to 24-bit samples at a sampling frequency of 48 kHz on all channels for both the DAC and ADC. The output data stream of the internal ADCs can be configured to use the CX\_SDOUT output and run at the CODEC\_SP clock speeds or to use the SAI\_SDOUT data output and run at the SAI\_SP rate. The CODEC\_SP and SAI\_SP can operate at different Fs rates.

Register / Bit Settings	Description
<b>Functional Mode Register (addr = 03h)</b>	
Set CODEC_FM <sub>x</sub> = 00,01,10	CX_LRCK can run at SSM, DSM, or QSM independent of SAI_LRCK
Set SAI_FM <sub>x</sub> = 00,01,10	SAI_LRCK can run at SSM, DSM, or QSM independent of CX_LRCK
Set ADC_SP SEL <sub>x</sub> = 00,01,10	Configure ADC data to use CX_SDOUT and CODEC_SP clocks, or SAI_SDOUT and SAI_SP clocks.
<b>Interface Format Register (addr = 04h)</b>	
Set DIF <sub>x</sub> bits to proper serial format	Select the digital interface format when not in one line mode
Set ADC_OL <sub>x</sub> bits = 00	Set ADC operating mode to Not One Line Mode since only 2 channels of ADC are supported
Set DAC_OL <sub>x</sub> bits = 00,01	Select DAC operating mode, see table below for valid combinations
<b>Misc. Control Register (addr = 05h)</b>	
Set CODEC_SP M/S = 0 or 1	Set CODEC Serial Port to master mode or slave mode.
Set SAI_SP M/S = 0 or 1	Set Serial Audio Interface Port to master mode or slave mode.
Set EXT ADC SCLK = 0	External ADCs are not used. Leave bit in default state.

CX_SDOUT= ADC Data SAI_SDOUT=ADC or S/PDIF Data		DAC Mode		
		Not One-Line Mode	One-Line Mode #1	One-Line Mode #2
ADC Mode	Not One-Line Mode	CX_SCLK=64 Fs CX_LRCK=SSM/DSM/QSM SAI_SCLK=64 Fs SAI_LRCK=SSM/DSM/QSM	CX_SCLK=128 Fs CX_LRCK=SSM/DSM SAI_SCLK=64 Fs SAI_LRCK=SSM/DSM/QSM	not valid
	One-Line Mode #1	not valid	not valid	not valid
	One-Line Mode #2	not valid	not valid	not valid

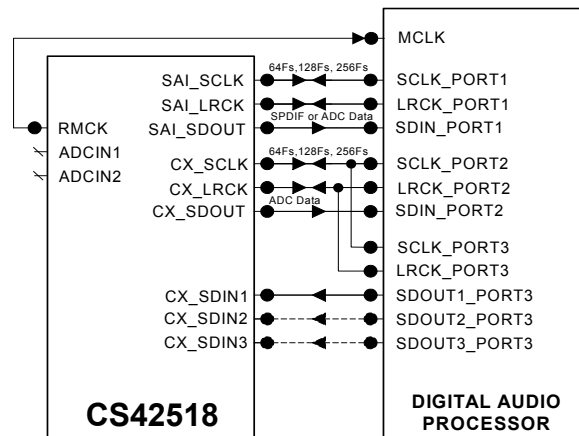


Figure 20. OLM Configuration #5

## 4.7 Control Port Description and Timing

The control port is used to access the registers, allowing the CS42526 to be configured for the desired operational modes and formats. The operation of the control port may be completely asynchronous with respect to the audio sample rates. However, to avoid potential interference problems, the control port pins should remain static if no operation is required.

The control port has two modes: SPI and I<sup>2</sup>C, with the CS42526 acting as a slave device. SPI mode is selected if there is a high-to-low transition on the AD0/ $\overline{\text{CS}}$  pin after the  $\overline{\text{RST}}$  pin has been brought high. I<sup>2</sup>C mode is selected by connecting the AD0/ $\overline{\text{CS}}$  pin through a resistor to VLC or DGND, thereby permanently selecting the desired AD0 bit address state.

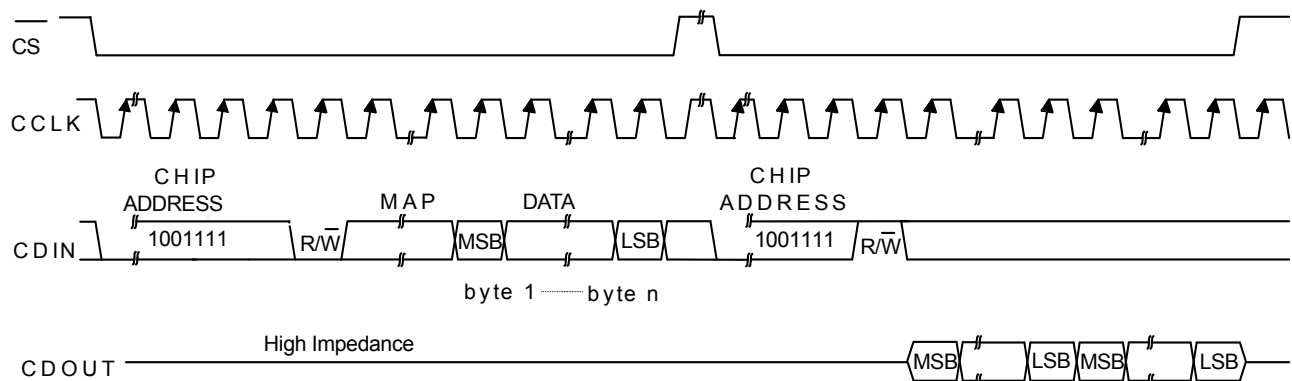
### 4.7.1 SPI Mode

In SPI mode,  $\overline{\text{CS}}$  is the CS42526 chip-select signal; CCLK is the control port bit clock (input into the CS42526 from the microcontroller); CDIN is the input data line from the microcontroller, and CDOUT is the output data line to the microcontroller. Data is clocked in on the rising edge of CCLK and out on the falling edge.

Figure 21 shows the operation of the control port in SPI mode. To write to a register, bring  $\overline{\text{CS}}$  low. The first seven bits on CDIN form the chip address and must be 1001111. The eighth bit is a read/write indicator (R/W), which should be low to write. The next eight bits form the Memory Address Pointer (MAP), which is set to the address of the register that is to be updated. The next eight bits are the data which will be placed into the register designated by the MAP. During writes, the CDOUT output stays in the Hi-Z state. It may be externally pulled high or low with a 47 k $\Omega$  resistor, if desired.

There is a MAP auto-increment capability, enabled by the INCR bit in the MAP register. If INCR is a zero, the MAP will stay constant for successive read or writes. If INCR is set to a 1, the MAP will auto-increment after each byte is read or written, allowing block reads or writes of successive registers.

To read a register, the MAP has to be set to the correct address by executing a partial write cycle which finishes ( $\overline{\text{CS}}$  high) immediately after the MAP byte. The MAP auto increment bit (INCR) may be set or not, as desired. To begin a read, bring  $\overline{\text{CS}}$  low, send out the chip address and set the read/write bit (R/W) high. The next falling edge of CCLK will clock out the MSB of the addressed register (CDOUT will leave the high impedance state). If the MAP auto-increment bit is set to 1, the data for successive registers will appear consecutively.



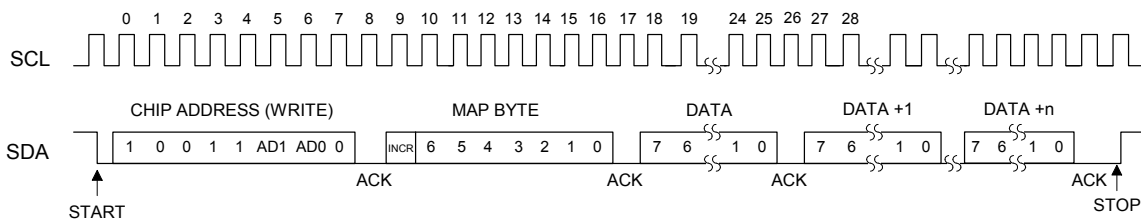
MAP = Memory Address Pointer, 8 bits, MSB first

**Figure 21. Control Port Timing in SPI Mode**

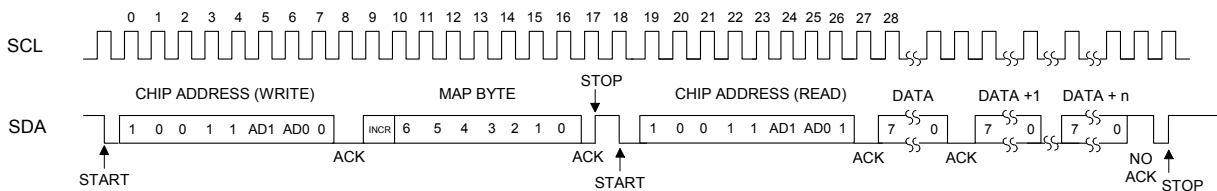
### 4.7.2 I<sup>2</sup>C Mode

In I<sup>2</sup>C mode, SDA is a bidirectional data line. Data is clocked into and out of the part by the clock, SCL. There is no  $\overline{CS}$  pin. Pins AD0 and AD1 form the two least-significant bits of the chip address and should be connected through a resistor to VLC or DGND as desired. The state of the pins is sensed while the CS42526 is being reset.

The signal timings for a read and write cycle are shown in [Figure 22](#) and [Figure 23](#). A Start condition is defined as a falling transition of SDA while the clock is high. A Stop condition is a rising transition while the clock is high. All other transitions of SDA occur while the clock is low. The first byte sent to the CS42526 after a Start condition consists of a 7-bit chip address field and a R/W bit (high for a read, low for a write). The upper 5 bits of the 7-bit address field are fixed at 10011. To communicate with a CS42526, the chip address field, which is the first byte sent to the CS42526, should match 10011, followed by the settings of the AD1 and AD0. The eighth bit of the address is the R/W bit. If the operation is a write, the next byte is the Memory Address Pointer (MAP) which selects the register to be read or written. If the operation is a read, the contents of the register pointed to by the MAP will be output. Setting the auto-increment bit in MAP allows successive reads or writes of consecutive registers. Each byte is separated by an acknowledge bit. The ACK bit is output from the CS42526 after each input byte is read and is input to the CS42526 from the microcontroller after each transmitted byte.



**Figure 22. Control Port Timing, I<sup>2</sup>C Write**



**Figure 23. Control Port Timing, I<sup>2</sup>C Read**

Since the read operation cannot set the MAP, an aborted write operation is used as a preamble. As shown in [Figure 23](#), the write operation is aborted after the acknowledge for the MAP byte by sending a stop condition. The following pseudocode illustrates an aborted write operation followed by a read operation.

- Send start condition.
- Send 10011x0 (chip address & write operation).
- Receive acknowledge bit.
- Send MAP byte, auto increment off.
- Receive acknowledge bit.
- Send stop condition, aborting write.

- Send start condition.
- Send 10011xx1(chip address & read operation).
- Receive acknowledge bit.
- Receive byte, contents of selected register.
- Send acknowledge bit.
- Send stop condition.

Setting the auto increment bit in the MAP allows successive reads or writes of consecutive registers. Each byte is separated by an acknowledge bit.

## 4.8 Interrupts

The CS42526 has a comprehensive interrupt capability. The INT output pin is intended to drive the interrupt input pin on the host microcontroller. The INT pin may be set to be active low, active high or active low with no active pull-up transistor. This last mode is used for active low, wired-OR hook-ups, with multiple peripherals connected to the microcontroller interrupt input pin.

Many conditions can cause an interrupt, as listed in the interrupt status register descriptions (see [“Interrupt Status \(address 20h\) \(Read Only\)” on page 63](#)). Each source may be masked off through mask register bits. In addition, each source may be set to rising edge, falling edge, or level-sensitive. Combined with the option of level-sensitive or edge-sensitive modes within the microcontroller, many different configurations are possible, depending on the needs of the equipment designer.

## 4.9 Reset and Power-Up

Reliable power-up can be accomplished by keeping the device in reset until the power supplies, clocks and configuration pins are stable. It is also recommended that reset be activated if the analog or digital supplies drop below the recommended operating condition to prevent power-glitch-related issues.

When  $\overline{RST}$  is low, the CS42526 enters a low-power mode and all internal states are reset, including the control port and registers, and the outputs are muted. When  $\overline{RST}$  is high, the control port becomes operational, and the desired settings should be loaded into the control registers. Writing a 0 to the PDN bit in the Power Control Register will then cause the part to leave the low-power state and begin operation. If the internal PLL is selected as the clock source, the serial audio outputs will be enabled after the PLL has settled (see [“Power Control \(address 02h\)” on page 46](#) for more details).

The delta-sigma modulators settle in a matter of microseconds after the analog section is powered, either through the application of power or by setting the  $\overline{RST}$  pin high. However, the voltage reference will take much longer to reach a final value due to the presence of external capacitance on the FILT+ pin. A time delay of approximately 80 ms is required after applying power to the device or after exiting a reset state. During this voltage reference ramp delay, all serial ports and DAC outputs will be automatically muted.

## 4.10 Power Supply, Grounding, and PCB Layout

As with any high-resolution converter, the CS42526 requires careful attention to power supply and grounding arrangements if its potential performance is to be realized. Figure 5 shows the recommended power arrangements, with VA and VARX connected to clean supplies. VD, which powers the digital circuitry, may be run from the system logic supply. Alternatively, VD may be powered from the analog supply via a ferrite bead. In this case, no additional devices should be powered from VD.

For applications where the output of the PLL is required to be low jitter, use a separate, low-noise analog +5 V supply for VARX, decoupled to AGND. In addition, a separate region of analog ground plane around the FILT+, VQ, LPFLT, REFGND, AGND, VA, VARX, RXP/and RXP0 pins is recommended.

Extensive use of power and ground planes, ground plane fill in unused areas and surface mount decoupling capacitors are recommended. Decoupling capacitors should be as near to the pins of the CS42526 as possible. The low value ceramic capacitor should be the nearest to the pin and should be mounted on the same side of the board as the CS42526 to minimize inductance effects. All signals, especially clocks, should be kept away from the FILT+, VQ and LPFLT pins in order to avoid unwanted coupling into the modulators and PLL. The FILT+ and VQ decoupling capacitors, particularly the 0.1  $\mu$ F, must be positioned to minimize the electrical path from FILT+ and REFGND. The CDB42528 evaluation board demonstrates the optimum layout and power supply arrangements.



## 5. REGISTER QUICK REFERENCE

Addr	Function	7	6	5	4	3	2	1	0
01h	ID <a href="#">page 45</a> default	Chip_ID3 1	Chip_ID2 1	Chip_ID1 1	Chip_ID0 1	Rev_ID3 X	Rev_ID2 X	Rev_ID1 X	Rev_ID0 X
02h	Power Control <a href="#">page 46</a> default	PDN_RCVR1 1	PDN_RCVR0 0	PDN_ADC 0	Reserved 0	PDN_DAC3 0	PDN_DAC2 0	PDN_DAC1 0	PDN 1
03h	Functional Mode <a href="#">page 45</a> default	CODEC_FM1 0	CODEC_FM0 0	SAI_FM1 0	SAI_FM0 0	ADC_SP_SEL1 0	ADC_SP_SEL0 0	DAC_DEM 0	RCVR_DEM 0
04h	Interface Formats <a href="#">page 49</a> default	DIF1 0	DIF0 1	ADC_OL1 0	ADC_OL0 0	DAC_OL1 0	DAC_OL0 0	SAI_RJ16 0	CODEC_RJ16 0
05h	Misc Control <a href="#">page 50</a> default	Ext ADC SCLK 0	HiZ_RMCK 0	Reserved 0	FREEZE 0	FILTSEL 0	HPF_FREEZE 0	CODEC_SP_M/S 0	SAI_SP_M/S 0
06h	Clock Control <a href="#">page 52</a> default	RMCK_DIV1 0	RMCK_DIV0 0	OMCK Freq1 0	OMCK Freq0 0	PLL_LRCK 0	SW_CTRL1 0	SW_CTRL0 0	FRC_PLL_LK 0
07h	OMCK/PLL_CLK Ratio <a href="#">page 53</a> default	RATIO7 X	RATIO6 X	RATIO5 X	RATIO4 X	RATIO3 X	RATIO2 X	RATIO1 X	RATIO0 X
08h	RVCR Status <a href="#">page 54</a> default	Digital Silence X	AES Format2 X	AES Format1 X	AES Format0 X	Active_CLK X	RVCR_CLK2 X	RVCR_CLK1 X	RVCR_CLK0 X
09h	Burst Preamble PC Byte 0 <a href="#">page 55</a> default	PC0-7 X	PC0-6 X	PC0-5 X	PC0-4 X	PC0-3 X	PC0-2 X	PC0-1 X	PC0-0 X
0Ah	Burst Preamble PC Byte 1 <a href="#">page 55</a> default	PC1-7 X	PC1-6 X	PC1-5 X	PC1-4 X	PC1-3 X	PC1-2 X	PC1-1 X	PC1-0 X
0Bh	Burst Preamble PD Byte 0 <a href="#">page 55</a> default	PD0-7 X	PD0-6 X	PD0-5 X	PD0-4 X	PD0-3 X	PD0-2 X	PD0-1 X	PD0-0 X
0Ch	Burst Preamble PD Byte 1 <a href="#">page 55</a> default	PD1-7 X	PD1-6 X	PD1-5 X	PD1-4 X	PD1-3 X	PD1-2 X	PD1-1 X	PD1-0 X
0Dh	Volume Control <a href="#">page 56</a> default	Reserved 0	SNGVOL 0	SZC1 0	SZC0 0	AMUTE 1	MUTE_SAI_SP 0	RAMP_UP 0	RAMP_DN 0
0Eh	Channel Mute <a href="#">page 58</a> default	Reserved 0	Reserved 0	B3_MUTE 0	A3_MUTE 0	B2_MUTE 0	A2_MUTE 0	B1_MUTE 0	A1_MUTE 0

Addr	Function	7	6	5	4	3	2	1	0
0Fh	Vol. Control A1 <a href="#">page 58</a> default	A1_VOL7 0	A1_VOL6 0	A1_VOL5 0	A1_VOL4 0	A1_VOL3 0	A1_VOL2 0	A1_VOL1 0	A1_VOL0 0
10h	Vol. Control B1 <a href="#">page 58</a> default	B1_VOL7 0	B1_VOL6 0	B1_VOL5 0	B1_VOL4 0	B1_VOL3 0	B1_VOL2 0	B1_VOL1 0	B1_VOL0 0
11h	Vol. Control A2 <a href="#">page 58</a> default	A2_VOL7 0	A2_VOL6 0	A2_VOL5 0	A2_VOL4 0	A2_VOL3 0	A2_VOL2 0	A2_VOL1 0	A2_VOL0 0
12h	Vol. Control B2 <a href="#">page 58</a> default	B2_VOL7 0	B2_VOL6 0	B2_VOL5 0	B2_VOL4 0	B2_VOL3 0	B2_VOL2 0	B2_VOL1 0	B2_VOL0 0
13h	Vol. Control A3 <a href="#">page 58</a> default	A3_VOL7 0	A3_VOL6 0	A3_VOL5 0	A3_VOL4 0	A3_VOL3 0	A3_VOL2 0	A3_VOL1 0	A3_VOL0 0
14h	Vol. Control B3 <a href="#">page 58</a> default	B3_VOL7 0	B3_VOL6 0	B3_VOL5 0	B3_VOL4 0	B3_VOL3 0	B3_VOL2 0	B3_VOL1 0	B3_VOL0 0
15h	Reserved <a href="#">page 58</a> default	Reserved 0	Reserved 0	Reserved 0	Reserved 0	Reserved 0	Reserved 0	Reserved 0	Reserved 0
16h	Reserved <a href="#">page 58</a> default	Reserved 0	Reserved 0	Reserved 0	Reserved 0	Reserved 0	Reserved 0	Reserved 0	Reserved 0
17h	Channel Invert <a href="#">page 58</a> default	Reserved 0	Reserved 0	INV_B3 0	INV_A3 0	INV_B2 0	INV_A2 0	INV_B1 0	INV_A1 0
18h	Mixing Ctrl Pair 1 <a href="#">page 58</a> default	P1_A=B 0	Reserved 0	Reserved 0	P1_ATAPI4 0	P1_ATAPI3 1	P1_ATAPI2 0	P1_ATAPI1 0	P1_ATAPI0 1
19h	Mixing Ctrl Pair 2 <a href="#">page 58</a> default	P2_A=B 0	Reserved 0	Reserved 0	P2_ATAPI4 0	P2_ATAPI3 1	P2_ATAPI2 0	P2_ATAPI1 0	P2_ATAPI0 1
1Ah	Mixing Ctrl Pair 3 <a href="#">page 58</a> default	P3_A=B 0	Reserved 0	Reserved 0	P3_ATAPI4 0	P3_ATAPI3 1	P3_ATAPI2 0	P3_ATAPI1 0	P3_ATAPI0 1
1Bh	Reserved <a href="#">page 58</a> default	Reserved 0	Reserved 0	Reserved 0	Reserved 0	Reserved 1	Reserved 0	Reserved 0	Reserved 1
1Ch	ADC Left Ch. Gain <a href="#">page 61</a> default	Reserved 0	Reserved 0	LGAIN5 0	LGAIN4 0	LGAIN3 0	LGAIN2 0	LGAIN1 0	LGAIN0 0
1Dh	ADC Right Ch. Gain <a href="#">page 61</a> default	Reserved 0	Reserved 0	RGAIN5 0	RGAIN4 0	RGAIN3 0	RGAIN2 0	RGAIN1 0	RGAIN0 0
1Eh	RCVR Mode Ctrl <a href="#">page 61</a> default	SP_SYNC 0	Reserved 0	DE-EMPH1 0	DE-EMPH0 0	INT1 0	INT0 0	HOLD1 0	HOLD0 0

Addr	Function	7	6	5	4	3	2	1	0
1Fh	RCVR Mode Ctrl 2 <a href="#">page 63</a> default	Reserved 0	TMUX2 0	TMUX1 0	TMUX0 0	Reserved 0	RMUX2 0	RMUX1 0	RMUX0 0
20h	Interrupt Status <a href="#">page 63</a> default	UNLOCK X	Reserved X	QCH X	DETC X	DETU X	Reserved X	OverFlow X	RERR X
21h	Interrupt Mask <a href="#">page 64</a> default	UNLOCKM 0	Reserved 0	QCHM 0	DETCM 0	DETUM 0	Reserved 0	OverFlowM 0	RERRM 0
22h	Interrupt Mode MSB <a href="#">page 65</a> default	UNLOCK1 0	Reserved 0	QCH1 0	DETC1 0	DETU1 0	Reserved 0	OF1 0	RERR1 0
23h	Interrupt Mode LSB <a href="#">page 65</a> default	UNLOCK0 0	Reserved 0	QCH0 0	DETC0 0	DETU0 0	Reserved 0	OF0 0	RERR0 0
24h	Buffer Ctrl <a href="#">page 65</a> default	LOCKM1 0	LOCKM0 1	Reserved 0	Reserved 0	Reserved 0	BSEL 0	CAM 0	CHS 0
25h	RCVR CS Data. <a href="#">page 66.</a> default	AUX3 0	AUX2 0	AUX1 0	AUX0 0	PRO 0	AUDIO 0	COPY 0	ORIG 0
26h	RCVR Errors <a href="#">page 67</a> default	Reserved 0	QCRC 0	CCRC 0	UNLOCK 0	V 0	CONF 0	BIP 0	PAR 0
27h	RCVR Errors Mask <a href="#">page 68</a> default	Reserved 0	QCRCM 0	CCRCM 0	UNLOCKM 0	VM 0	CONFM 0	BIPM 0	PARM 0
28h	MUTEC <a href="#">page 69</a> default	Reserved 0	Reserved 0	MCPolarity 0	M_AOUTA1 1	M_AOUTB1 1	M_AOUTA2 M_AOUTB2 1	M_AOUTA3 M_AOUTB3 1	Reserved 1
29h	RXP7/GPO 7 <a href="#">page 69</a> default	Mode1 0	Mode0 0	Polarity 0	Function4 0	Function3 0	Function2 0	Function1 0	Function0 0
2Ah	RXP6/GPO 6 <a href="#">page 69</a> default	Mode1 0	Mode0 0	Polarity 0	Function4 0	Function3 0	Function2 0	Function1 0	Function0 0
2Bh	RXP5/GPO 5 <a href="#">page 69</a> default	Mode1 0	Mode0 0	Polarity 0	Function4 0	Function3 0	Function2 0	Function1 0	Function0 0
2Ch	RXP4/GPO 4 <a href="#">page 69</a> default	Mode1 0	Mode0 0	Polarity 0	Function4 0	Function3 0	Function2 0	Function1 0	Function0 0
2Dh	RXP3/GPO 3 <a href="#">page 69</a> default	Mode1 0	Mode0 0	Polarity 0	Function4 0	Function3 0	Function2 0	Function1 0	Function0 0

Addr	Function	7	6	5	4	3	2	1	0
2Eh	RXP2/GPO 2 <a href="#">page 69</a> default	Mode1 0	Mode0 0	Polarity 0	Function4 0	Function3 0	Function2 0	Function1 0	Function0 0
2Fh	RXP1/GPO 1 <a href="#">page 69</a> default	Mode1 0	Mode0 0	Polarity 0	Function4 0	Function3 0	Function2 0	Function1 0	Function0 0
30h	Q Subcode <a href="#">page 71</a> default	Address3 X	Address2 X	Address1 X	Address0 X	Control3 X	Control2 X	Control1 X	Control0 X
31h	Q Subcode <a href="#">page 71</a> default	Track7 X	Track6 X	Track5 X	Track4 X	Track3 X	Track2 X	Track1 X	Track0 X
32h	Q Subcode <a href="#">page 71</a> default	Index7 X	Index6 X	Index5 X	Index4 X	Index3 X	Index2 X	Index1 X	Index0 X
33h	Q Subcode <a href="#">page 71</a> default	Minute7 X	Minute6 X	Minute5 X	Minute4 X	Minute3 X	Minute2 X	Minute1 X	Minute0 X
34h	Q Subcode <a href="#">page 71</a> default	Second7 X	Second6 X	Second5 X	Second4 X	Second3 X	Second2 X	Second1 X	Second0 X
35h	Q Subcode <a href="#">page 71</a> default	Frame7 X	Frame6 X	Frame5 X	Frame4 X	Frame3 X	Frame2 X	Frame1 X	Frame0 X
36h	Q Subcode <a href="#">page 71</a> default	Zero7 X	Zero6 X	Zero5 X	Zero4 X	Zero3 X	Zero2 X	Zero1 X	Zero0 X
37h	Q Subcode <a href="#">page 71</a> default	A.Minute7 X	A.Minute6 X	A.Minute5 X	A.Minute4 X	A.Minute3 X	A.Minute2 X	A.Minute1 X	A.Minute0 X
38h	Q Subcode <a href="#">page 71</a> default	A.Second7 X	A.Second6 X	A.Second5 X	A.Second4 X	A.Second3 X	A.Second2 X	A.Second1 X	A.Second0 X
39h	Q Subcode <a href="#">page 71</a> default	A.Frame7 X	A.Frame6 X	A.Frame5 X	A.Frame4 X	A.Frame3 X	A.Frame2 X	A.Frame1 X	A.Frame0 X
3Ah - 51h	C or U Data Buffer <a href="#">page 71</a> default	CU Buffer7 X	CU Buffer6 X	CU Buffer5 X	CU Buffer4 X	CU Buffer3 X	CU Buffer2 X	CU Buffer1 X	CU Buffer0 X

## 6. REGISTER DESCRIPTION

All registers are read/write except for the I.D. and Revision Register, OMCK/PLL\_CLK Ratio Register, Interrupt Status Register, and Q-Channel Subcode Bytes and C-bit or U-bit Data Buffer, which are read only. See the following bit definition tables for bit assignment information. The default state of each bit after a power-up sequence or reset is listed in each bit description.

### 6.1 Memory Address Pointer (MAP)

Not a register

7	6	5	4	3	2	1	0
INCR	MAP6	MAP5	MAP4	MAP3	MAP2	MAP1	MAP0

#### 6.1.1 INCREMENT (INCR)

*Default = 1*

Function:

Memory Address Pointer auto increment control

- 0 - MAP is not incremented automatically.
- 1 - Internal MAP is automatically incremented after each read or write.

#### 6.1.2 MEMORY ADDRESS POINTER (MAPX)

*Default = 0000001*

Function:

Memory Address Pointer (MAP). Sets the register address that will be read or written by the control port.

### 6.2 Chip I.D. and Revision Register (address 01h) (Read Only)

7	6	5	4	3	2	1	0
Chip_ID3	Chip_ID2	Chip_ID1	CHIP_ID0	Rev_ID3	Rev_ID2	Rev_ID1	Rev_ID0

#### 6.2.1 CHIP I.D. (CHIP\_IDX)

*Default = 1111*

Function:

I.D. code for the CS42526. Permanently set to 1111.

#### 6.2.2 CHIP REVISION (REV\_IDX)

*Default = xxxx*

Function:

CS42526 revision level.

Revision D is coded as 0100.

Revision C is coded as 0011.

### 6.3 Power Control (address 02h)

7	6	5	4	3	2	1	0
PDN_RCVR1	PDN_RCVR0	PDN_ADC	Reserved	PDN_DAC3	PDN_DAC2	PDN_DAC1	PDN

#### 6.3.1 POWER DOWN RECEIVER (PDN\_RCVRX)

*Default = 10*

00 - Receiver and PLL in normal operational mode.

01 - Receiver and PLL held in a reset state. Equivalent to setting 11.

10 - Reserved.

11 - Receiver and PLL held in a reset state. Equivalent to setting 01.

*Function:*

Places the S/PDIF receiver and PLL in a reset state. It is advised that any change of these bits be made while the DACs are muted or the power-down bit (PDN) is enabled to eliminate the possibility of audible artifacts.

It should be noted that, for Revision C compatibility, PDN\_RCVR1 may be set to '0' and receiver operation may be controlled with the PDN\_RCVR0 bit.

#### 6.3.2 POWER DOWN ADC (PDN\_ADC)

*Default = 0*

*Function:*

When enabled the stereo analog to digital converter will remain in a reset state. It is advised that any change of this bit be made while the DACs are muted or the power-down bit (PDN) is enabled to eliminate the possibility of audible artifacts.

#### 6.3.3 POWER DOWN RESERVE TEST (PDN\_RSVD)

*Default = 0*

*Function:*

This bit is a reserved power down bit used for test purposes only. For proper operation, this bit must be set to '1'.

#### 6.3.4 POWER DOWN DAC PAIRS (PDN\_DACX)

*Default = 0*

*Function:*

When enabled the respective DAC channel pair x (AOUTAx and AOUTBx) will remain in a reset state.

#### 6.3.5 POWER DOWN (PDN)

*Default = 1*

*Function:*

The entire device will enter a low-power state when this function is enabled, and the contents of the control registers are retained in this mode. The power-down bit defaults to 'enabled' on power-up and must be disabled before normal operation can occur.

## 6.4 Functional Mode (address 03h)

7	6	5	4	3	2	1	0
CODEC_FM1	CODEC_FM0	SAI_FM1	SAI_FM0	ADC_SP_SEL1	ADC_SP_SEL0	DAC_DEM	RCVR_DEM

### 6.4.1 CODEC FUNCTIONAL MODE (CODEC\_FMX)

*Default = 00*

- 00 - Single-Speed Mode (4 to 50 kHz sample rates)
- 01 - Double-Speed Mode (50 to 100 kHz sample rates)
- 10 - Quad-Speed Mode (100 to 192 kHz sample rates)
- 11 - Reserved

Function:

Selects the required range of sample rates for all converters clocked from the Codec serial port (CODEC\_SP). Bits must be set to the corresponding sample rate range when the CODEC\_SP is in Master or Slave Mode.

### 6.4.2 SERIAL AUDIO INTERFACE FUNCTIONAL MODE (SAI\_FMX)

*Default = 00*

- 00 - Single-Speed Mode (4 to 50 kHz sample rates)
- 01 - Double-Speed Mode (50 to 100 kHz sample rates)
- 10 - Quad-Speed Mode (100 to 192 kHz sample rates)
- 11 - Reserved

Function:

Selects the required range of sample rates for the Serial Audio Interface port (SAI\_SP). These bits must be set to the corresponding sample rate range when the SAI\_SP is in Master or Slave Mode.

### 6.4.3 ADC SERIAL PORT SELECT (ADC\_SP\_SELX)

*Default = 00*

- 00 - Serial data on CX\_SDOOUT pin, clocked from the CODEC\_SP. S/PDIF data on SAI\_SDOOUT pin.
- 01 - Serial data on CX\_SDOOUT pin, clocked from the SAI\_SP. S/PDIF data on SAI\_SDOOUT pin.
- 10 - Serial data on SAI\_SDOOUT pin, clocked from the SAI\_SP. No S/PDIF data available.
- 11 - Reserved

Function:

Selects the desired clocks and routing for the ADC serial output.

### 6.4.4 DAC DE-EMPHASIS CONTROL (DAC\_DEM)

*Default = 0*

Function:

Enables the digital filter to maintain the standard 15 $\mu$ s/50 $\mu$ s digital de-emphasis filter response at the auto-detected sample rate of either 32, 44.1, or 48 kHz. De-emphasis will not be enabled, regardless of this register setting, at any other sample rate. If the FRC\_PLL\_LK bit is set to a '1'b, the auto-detect sample rate feature is disabled. To apply the correct de-emphasis filter, use the DE-EMPH bits in the

Receiver Mode Control (address 1Eh) register to set the appropriate sample rate.

DAC_DEM reg03h[1]	FRC_PLL_LK reg06h[0]	DE-EMPH[1:0] reg1Eh[5:4]	De-Emphasis Mode
0	X	XX	No De-Emphasis
1	0	XX	Auto-Detect Fs
1	1	00	Reserved
		01	32 kHz
		10	44.1 kHz
		11	48 kHz

**Table 5. DAC De-Emphasis**

#### 6.4.5 RECEIVER DE-EMPHASIS CONTROL (RCVR\_DEM)

*Default = 0*

Function:

When enabled, de-emphasis will be automatically applied when emphasis is detected based on the channel status bits. The appropriate digital filter will be selected to maintain the standard 15 $\mu$ s/50 $\mu$ s digital de-emphasis filter response at the auto-detected sample rate of either 32, 44.1, or 48 kHz. If the FRC\_PLL\_LK bit is set to a '1'b, then the auto-detect sample rate feature is disabled. To apply the correct de-emphasis filter, use the DE-EMPH bits in the Receiver Mode Control (address 1Eh) register to set the appropriate sample rate.

RCVR_DEM reg03h[0]	FRC_PLL_LK reg06h[0]	DE-EMPH[1:0] reg1Eh[5:4]	De-Emphasis Mode
0	X	XX	No De-Emphasis
1	0	XX	Auto-Detect Fs
1	1	00	Reserved
		01	32 kHz
		10	44.1 kHz
		11	48 kHz

**Table 6. Receiver De-Emphasis**



## 6.5 Interface Formats (address 04h)

7	6	5	4	3	2	1	0
DIF1	DIF0	ADC_OL1	ADC_OL0	DAC_OL1	DAC_OL0	SAI_RJ16	CODEC_RJ16

### 6.5.1 DIGITAL INTERFACE FORMAT (DIFX)

*Default = 01*

Function:

These bits select the digital interface format used for the CODEC Serial Port and Serial Audio Interface Port when not in One-Line Mode. The required relationship between the Left/Right clock, serial clock, and serial data is defined by the Digital Interface Format and the options are detailed in [11-12](#).

DIF1	DIF0	Description	Format	Figure
0	0	Left-Justified, up to 24-bit data	0	<a href="#">11</a>
0	1	I <sup>2</sup> S, up to 24-bit data	1	<a href="#">10</a>
1	0	Right-Justified, 16-bit or 24-bit data	2	<a href="#">12</a>
1	1	Reserved	-	-

**Table 7. Digital Interface Formats**

### 6.5.2 ADC ONE\_LINE MODE (ADC\_OLX)

*Default = 00*

Function:

These bits select which mode the ADC will use. By default, One-Line Mode is disabled, but it can be selected using these bits. Please see [Figures 13 and 14](#) to see the format of One-Line Mode 1 and One-Line Mode 2.

ADC_OL1	ADC_OL0	Description	Format	Figure
0	0	DIF: take the DIF setting from reg04h[7:6]	-	-
0	1	One-Line #1	3	<a href="#">13</a>
1	0	One-Line #2	4	<a href="#">14</a>
1	1	Reserved	-	-

**Table 8. ADC One-Line Mode**

### 6.5.3 DAC ONE\_LINE MODE (DAC\_OLX)

*Default = 00*

Function:

These bits select which mode the DAC will use. By default, One-Line Mode is disabled, but it can be selected using these bits. Please see [Figures 13 and 14](#) to see the format of One-Line Mode 1 and One-Line Mode 2.

DAC_OL1	DAC_OL0	Description	Format	Figure
0	0	DIF: take the DIF setting from reg04h[7:6]	-	-
0	1	One-Line #1	3	<a href="#">13</a>
1	0	One-Line #2	4	<a href="#">14</a>
1	1	Reserved	-	-

**Table 9. DAC One-Line Mode**

### 6.5.4 SAI RIGHT-JUSTIFIED BITS (SAI\_RJ16)

*Default = 0*

Function:

This bit determines how many bits to use during right-justified mode for the Serial Audio Interface Port. By default the receiver will be in RJ24 bits but can be set to RJ16 bits.

0 - 24 bit mode.

1 - 16 bit mode.

### 6.5.5 CODEC RIGHT-JUSTIFIED BITS (CODEC\_RJ16)

*Default = 0*

Function:

This bit determines how many bits to use during Right-Justified Mode for the DAC and ADC within the CODEC Serial Port. By default, the DAC and ADC will be in RJ24 bits, but can be set to RJ16 bits.

0 - 24 bit mode.

1 - 16 bit mode.

## 6.6 Misc Control (address 05h)

7	6	5	4	3	2	1	0
Ext ADC SCLK	HiZ_RMCK	Reserved	FREEZE	FILT_SEL	HPF_FREEZE	CODEC_SP M/S	SAI_SP M/S

### 6.6.1 EXTERNAL ADC SCLK SELECT (EXT ADC SCLK)

*Default = 0*

Function:

This bit identifies the SCLK source for the external ADCs attached to the ADCIN1/2 ports when using One-Line Mode of operation.

0 - SAI\_SCLK is used as external ADC SCLK.

1 - CX\_SCLK is used as external ADC SCLK.

### 6.6.2 RMCK HIGH IMPEDANCE (HIZ\_RMCK)

*Default = 0*

Function:

This bit is used to create a high-impedance output on RMCK when the clock signal is not required.

### 6.6.3 FREEZE CONTROLS (FREEZE)

*Default = 0*

Function:

This function will freeze the previous output of, and allow modifications to be made to, the Volume Control (address 0Fh-16h), Channel Invert (address 17h), and Mixing Control Pair (address 18h-1Bh) registers without the changes taking effect until the FREEZE is disabled. To make multiple changes in these control port registers take effect simultaneously, enable the FREEZE bit, make all register changes, then disable the FREEZE bit.

#### 6.6.4 INTERPOLATION FILTER SELECT (FILT\_SEL)

*Default = 0*

Function:

This feature allows the user to select whether the DAC interpolation filter has a fast- or slow roll-off. For filter characteristics, please See [“D/A Digital Filter Characteristics” on page 10](#).

0 - Fast roll-off.

1 - Slow roll-off.

#### 6.6.5 HIGH-PASS FILTER FREEZE (HPF\_FREEZE)

*Default = 0*

Function:

When this bit is set, the internal high-pass filter for the selected channel will be disabled. The current DC offset value will be frozen and continue to be subtracted from the conversion result. See [“A/D Digital Filter Characteristics” on page 8](#).

#### 6.6.6 CODEC SERIAL PORT MASTER/SLAVE SELECT (CODEC\_SP M/ $\bar{S}$ )

*Default = 0*

Function:

In Master Mode, CX\_SCLK and CX\_LRCK are outputs. Internal dividers will divide the master clock to generate the serial clock and left/right clock. In Slave Mode, CX\_SCLK and CX\_LRCK become inputs.

If the CX\_SP is in Slave Mode, CX\_LRCK must be present for proper device operation.

#### 6.6.7 SERIAL AUDIO INTERFACE SERIAL PORT MASTER/SLAVE SELECT (SAI\_SP M/ $\bar{S}$ )

*Default = 0*

Function:

In Master Mode, SAI\_SCLK and SAI\_LRCK are outputs. Internal dividers will divide the master clock to generate the serial clock and left/right clock. In Slave Mode, SAI\_SCLK and SAI\_LRCK become inputs.

If the SAI\_SP is in Slave Mode, SAI\_LRCK must be present for proper device operation.

## 6.7 Clock Control (address 06h)

7	6	5	4	3	2	1	0
RMCK_DIV1	RMCK_DIV0	OMCK Freq1	OMCK Freq0	PLL_LRCK	SW_CTRL1	SW_CTRL0	FRC_PLL_LK

### 6.7.1 RMCK DIVIDE (RMCK\_DIVX)

*Default = 00*

Function:

Divides/multiplies the internal MCLK, either from the PLL or OMCK, by the selected factor.

RMCK_DIV1	RMCK_DIV0	Description
0	0	Divide by 1
0	1	Divide by 2
1	0	Divide by 4
1	1	Multiply by 2

**Table 10. RMCK Divider Settings**

### 6.7.2 OMCK FREQUENCY (OMCK\_FREQX)

*Default = 00*

Function:

Sets the appropriate frequency for the supplied OMCK.

OMCK Freq1	OMCK Freq0	Description
0	0	11.2896 MHz or 12.2880 MHz
0	1	16.9344 MHz or 18.4320 MHz
1	0	22.5792 MHz or 24.5760 MHz
1	1	Reserved

**Table 11. OMCK Frequency Settings**

### 6.7.3 PLL LOCK TO LRCK (PLL\_LRCK)

*Default = 0*

*0 - Disabled*

*1 - Enabled*

Function:

When enabled, the internal PLL of the CS42526 will lock to the SAI\_LRCK of the SAI serial port.

### 6.7.4 MASTER CLOCK SOURCE SELECT (SW\_CTRLX)

Default = 00

Function:

These two bits, along with the UNLOCK bit in register “Interrupt Status (address 20h) (Read Only)” on page 63, determine the master clock source for the CS42526. When SW\_CTRL1 and SW\_CTRL0 are set to '00'b, selecting the output of the PLL as the internal clock source, and the PLL becomes unlocked, RMCK will equal OMCK, but all internal and serial port timings are not valid.

When the FRC\_PLL\_LK bit is set to '1'b, the SW\_CTRLX bits must be set to '00'b. If the PLL becomes unlocked when the FRC\_PLL\_LK bit is set to '1'b, RMCK will not equal OMCK.

SW_CTRL1	SW_CTRL0	UNLOCK	Description
0	0	X	Manual setting, MCLK sourced from PLL.
0	1	X	Manual setting, MCLK sourced from OMCK.
1	0	0 1	Hold, keep same MCLK source. Auto switch, MCLK sourced from OMCK.
1	1	0 1	Auto switch, MCLK sourced from PLL. Auto switch, MCLK sourced from OMCK.

**Table 12. Master Clock Source Select**

### 6.7.5 FORCE PLL LOCK (FRC\_PLL\_LK)

Default = 0

Function:

This bit is used to enable the PLL to lock to the S/PDIF input stream or the SAI\_LRCK with the absence of a clock signal on OMCK. When set to a '1'b, the auto-detect sample frequency feature will be disabled and the SW\_CTRLX bits must be set to '00'b. The OMCK/PLL\_CLK Ratio (address 07h) (Read Only) register contents are not valid, and the PLL\_CLK[2:0] bits will be set to '111'b. Use the DE-EMPH[1:0] bits to properly apply de-emphasis filtering.

## 6.8 OMCK/PLL\_CLK Ratio (address 07h) (Read Only)

7	6	5	4	3	2	1	0
RATIO7(2 <sup>1</sup> )	RATIO6(2 <sup>0</sup> )	RATIO5(2 <sup>-1</sup> )	RATIO4(2 <sup>-2</sup> )	RATIO3(2 <sup>-3</sup> )	RATIO2(2 <sup>-4</sup> )	RATIO1(2 <sup>-5</sup> )	RATIO0(2 <sup>-6</sup> )

### 6.8.1 OMCK/PLL\_CLK RATIO (RATIOX)

Default = xxxxxxxx

Function:

This register allows the user to find the exact absolute frequency of the recovered MCLK coming from the PLL. This value is represented as an integer (RATIO7:6) and a fractional (RATIO5:0) part. For example, an OMCK/PLL\_CLK ratio of 1.5 would be displayed as 60h.

## 6.9 RVCR Status (address 08h) (Read Only)

7	6	5	4	3	2	1	0
Digital Silence	AES Format2	AES Format1	AES Format0	Active_CLK	RVCR_CLK2	RVCR_CLK1	RVCR_CLK0

### 6.9.1 DIGITAL SILENCE DETECTION (DIGITAL SILENCE)

*Default = x*

*0 - Digital Silence not detected*

*1 - Digital Silence detected*

Function:

The CS42526 will auto-detect a digital silence condition when 1548 consecutive zeros have been detected.

### 6.9.2 AES FORMAT DETECTION (AES FORMATX)

*Default = xxx*

Function:

The CS42526 will auto-detect the AES format of the incoming S/PDIF stream and display the information according to the following table.

AES Format2	AES Format1	AES Format0	Description
0	0	0	Linear PCM
0	0	1	DTS®-CD
0	1	0	DTS®-LD
0	1	1	HDCD®
1	0	0	IEC 61937
1	0	1	Reserved
1	1	0	Reserved
1	1	1	Reserved

**Table 13. AES Format Detection**

### 6.9.3 SYSTEM CLOCK SELECTION (ACTIVE\_CLK)

*Default = x*

*0 - Output of PLL*

*1 - OMCK*

Function:

This bit identifies the source of the internal system clock (MCLK).

### 6.9.4 RECEIVER CLOCK FREQUENCY (RCVR\_CLKX)

*Default = xxx*

Function:

The CS42526 detects the ratio between the OMCK and the recovered clock from the PLL. Given the absolute frequency of OMCK, this ratio may be used to determine the absolute frequency of the PLL clock.

If a 12.2880 MHz, 18.4320 MHz, or 24.5760 MHz clock is applied to OMCK and the OMCK\_FREQX bits are set accordingly (see “OMCK Frequency (OMCK Freqx)” on page 52), the absolute frequency of the PLL clock is reflected in the RCVR\_CLKX bits according to Table 16. If the absolute frequency of the PLL clock does not match one of the frequencies given in Table 16, these bits will reflect the closest available value.

If the frequency of OMCK is not equal to 12.2880 MHz, 18.4320 MHz, or 24.5760 MHz, the contents of the RCVR\_CLKX bits will be inaccurate and should be disregarded. In this case, an external controller may use the contents of the OMCK/PLL\_CLK ratio register and the known OMCK frequency to determine the absolute frequency of the PLL clock.

**Note:** These bits are set to ‘111’b when the FRC\_PLL\_LK bit is ‘1’b.

RCVR_CLK2	RCVR_CLK1	RCVR_CLK0	Description
0	0	0	8.1920 MHz
0	0	1	11.2896 MHz
0	1	0	12.288 MHz
0	1	1	16.3840 MHz
1	0	0	22.5792 MHz
1	0	1	24.5760 MHz
1	1	0	45.1584 MHz
1	1	1	49.1520 MHz

**Table 14. Receiver Clock Frequency Detection**

### 6.10 Burst Preamble PC and PD Bytes (addresses 09h - 0Ch)(Read Only)

7	6	5	4	3	2	1	0
PCx-7	PCx-6	PCx-5	PCx-4	PCx-3	PCx-2	PCx-1	PCx-0
PDx-7	PDx-6	PDx-5	PDx-4	PDx-3	PDx-2	PDx-1	PDx-0

#### 6.10.1 BURST PREAMBLE BITS (PCX & PDX)

*Default = xxh*

Function:

The PC and PD burst preamble bytes are loaded into these four registers.

## 6.11 Volume Transition Control (address 0Dh)

7	6	5	4	3	2	1	0
Reserved	SNGVOL	SZC1	SZC0	AMUTE	MUTE_SAI_SP	RAMP_UP	RAMP_DN

### 6.11.1 SINGLE VOLUME CONTROL (SNGVOL)

*Default = 0*

Function:

The individual channel volume levels are independently controlled by their respective Volume Control registers when this function is disabled. When enabled, the volume on all channels is determined by the A1 Channel Volume Control register and the other Volume Control registers are ignored.

### 6.11.2 SOFT RAMP AND ZERO CROSS CONTROL (SZCX)

*Default = 00*

00 - Immediate Change

01 - Zero Cross

10 - Soft Ramp

11 - Soft Ramp on Zero Crossings

Function:

#### Immediate Change

When Immediate Change is selected, all level changes will take effect immediately in one step.

#### Zero Cross

Zero Cross Enable dictates that signal-level changes, either by attenuation changes or muting, will occur on a signal zero crossing to minimize audible artifacts. The requested level-change will occur after a timeout period between 512 and 1024 sample periods (10.7 ms to 21.3 ms at 48 kHz sample rate) if the signal does not encounter a zero crossing. The zero cross function is independently monitored and implemented for each channel.

#### Soft Ramp

Soft Ramp allows level changes, both muting and attenuation, to be implemented by incrementally ramping, in 1/8 dB steps, from the current level to the new level at a rate of 1 dB per 8 left/right clock periods.

#### Soft Ramp on Zero Crossing

Soft Ramp and Zero Cross Enable dictates that signal level changes, either by attenuation changes or muting, will occur in 1/8 dB steps and be implemented on a signal zero crossing. The 1/8 dB level change will occur after a timeout period between 512 and 1024 sample periods (10.7 ms to 21.3 ms at 48 kHz sample rate) if the signal does not encounter a zero crossing. The zero cross function is independently monitored and implemented for each channel.



### 6.11.3 AUTO-MUTE (AMUTE)

*Default = 1*

0 - Disabled

1 - Enabled

Function:

The digital-to-analog converters of the CS42526 will mute the output following the reception of 8192 consecutive audio samples of static 0 or -1. A single sample of non-static data will release the mute. Detection and muting is done independently for each channel. The quiescent voltage on the output will be retained, and the MUTE pin will go active during the mute period. The muting function is affected, similar to volume control changes, by the Soft and Zero Cross bits (SZC[1:0]).

### 6.11.4 SERIAL AUDIO INTERFACE SERIAL PORT MUTE (MUTE\_SAI\_SP)

*Default = 0*

0 - Disabled

1 - Enabled

Function:

When enabled, the Serial Audio Interface port (SAI\_SP) will be muted.

### 6.11.5 SOFT VOLUME RAMP-UP AFTER ERROR (RMP\_UP)

*Default = 0*

0 - Disabled

1 - Enabled

Function:

An un-mute will be performed after executing a filter mode change, after a MCLK/LRCK ratio change or error, and after changing the Functional Mode. When this feature is enabled, this un-mute is affected, similar to attenuation changes, by the Soft and Zero Cross bits (SZC[1:0]). When disabled, an immediate un-mute is performed in these instances.

**Note:** For best results, it is recommended that this bit be used in conjunction with the RMP\_DN bit.

### 6.11.6 SOFT RAMP-DOWN BEFORE FILTER MODE CHANGE (RMP\_DN)

*Default = 0*

0 - Disabled

1 - Enabled

Function:

A mute will be performed prior to executing a filter mode or de-emphasis mode change. When this feature is enabled, this mute is affected, similar to attenuation changes, by the Soft and Zero Cross bits (SZC[1:0]). When disabled, an immediate mute is performed prior to executing a filter mode or de-emphasis mode change.

**Note:** For best results, it is recommended that this bit be used in conjunction with the RMP\_UP bit.

### 6.12 Channel Mute (address 0Eh)

7	6	5	4	3	2	1	0
Reserved	Reserved	B3_MUTE	A3_MUTE	B2_MUTE	A2_MUTE	B1_MUTE	A1_MUTE

#### 6.12.1 INDEPENDENT CHANNEL MUTE (XX\_MUTE)

*Default = 0*

0 - Disabled

1 - Enabled

Function:

The digital-to-analog converter outputs of the CS42526 will mute when enabled. The quiescent voltage on the outputs will be retained. The muting function is affected, similar to attenuation changes, by the Soft and Zero Cross bits (SZC[1:0]).

### 6.13 Volume Control (addresses 0Fh, 10h, 11h, 12h, 13h, 14h)

7	6	5	4	3	2	1	0
xx_VOL7	xx_VOL6	xx_VOL5	xx_VOL4	xx_VOL3	xx_VOL2	xx_VOL1	xx_VOL0

#### 6.13.1 VOLUME CONTROL (XX\_VOL)

*Default = 0*

Function:

The Digital Volume Control registers allow independent control of the signal levels in 0.5 dB increments from 0 to -127 dB. Volume settings are decoded as shown in [Table 15](#). The volume changes are implemented as dictated by the Soft and Zero Cross bits (SZC[1:0]). All volume settings less than -127 dB are equivalent to enabling the MUTE bit for the given channel.

Binary Code	Decimal Value	Volume Setting
00000000	0	0 dB
00101000	40	-20 dB
01010000	80	-40 dB
01111000	120	-60 dB
10110100	180	-90 dB

Table 15. Example Digital Volume Settings

### 6.14 Channel Invert (address 17h)

7	6	5	4	3	2	1	0
Reserved	Reserved	INV_B3	INV_A3	INV_B2	INV_A2	INV_B1	INV_A1

#### 6.14.1 INVERT SIGNAL POLARITY (INV\_XX)

*Default = 0*

0 - Disabled

1 - Enabled

Function:

When enabled, these bits will invert the signal polarity of their respective channels.

### 6.15 Mixing Control Pair 1 (Channels A1 & B1) (address 18h)

---

**Mixing Control Pair 2 (Channels A2 & B2) (address 19h)**

**Mixing Control Pair 3 (Channels A3 & B3) (address 1Ah)**

7	6	5	4	3	2	1	0
Px_A=B	Reserved	Reserved	Px_ATAPI4	Px_ATAPI3	Px_ATAPI2	Px_ATAPI1	Px_ATAPI0

#### 6.15.1 CHANNEL A VOLUME = CHANNEL B VOLUME (PX\_A=B)

*Default = 0*

0 - Disabled

1 - Enabled

Function:

The AOUTAx and AOUTBx volume levels are independently controlled by the A and the B Channel Volume Control registers when this function is disabled. The volume on both AOUTAx and AOUTBx are determined by the A Channel Volume Control registers (per A-B pair), and the B Channel Volume Control registers are ignored when this function is enabled.

**6.15.2 ATAPI CHANNEL-MIXING AND MUTING (PX\_ATAPIX)**

Default = 01001

Function:

The CS42526 implements the channel-mixing functions of the ATAPI CD-ROM specification. The AT-API functions are applied per A-B pair. Refer to [Table 16](#) and [Figure 8](#) for additional information.

ATAPI4	ATAPI3	ATAPI2	ATAPI1	ATAPI0	AOUTAx	AOUTBx
0	0	0	0	0	MUTE	MUTE
0	0	0	0	1	MUTE	bR
0	0	0	1	0	MUTE	bL
0	0	0	1	1	MUTE	b[(L+R)/2]
0	0	1	0	0	aR	MUTE
0	0	1	0	1	aR	bR
0	0	1	1	0	aR	bL
0	0	1	1	1	aR	b[(L+R)/2]
0	1	0	0	0	aL	MUTE
0	1	0	0	1	aL	bR
0	1	0	1	0	aL	bL
0	1	0	1	1	aL	b[(L+R)/2]
0	1	1	0	0	a[(L+R)/2]	MUTE
0	1	1	0	1	a[(L+R)/2]	bR
0	1	1	1	0	a[(L+R)/2]	bL
0	1	1	1	1	a[(L+R)/2]	b[(L+R)/2]
1	0	0	0	0	MUTE	MUTE
1	0	0	0	1	MUTE	bR
1	0	0	1	0	MUTE	bL
1	0	0	1	1	MUTE	[(aL+bR)/2]
1	0	1	0	0	aR	MUTE
1	0	1	0	1	aR	bR
1	0	1	1	0	aR	bL
1	0	1	1	1	aR	[(bL+aR)/2]
1	1	0	0	0	aL	MUTE
1	1	0	0	1	aL	bR
1	1	0	1	0	aL	bL
1	1	0	1	1	aL	[(aL+bR)/2]
1	1	1	0	0	[(aL+bR)/2]	MUTE
1	1	1	0	1	[(aL+bR)/2]	bR
1	1	1	1	0	[(bL+aR)/2]	bL
1	1	1	1	1	[(aL+bR)/2]	[(aL+bR)/2]

**Table 16. ATAPI Decode**

**6.16 ADC Left Channel Gain (address 1Ch)**

7	6	5	4	3	2	1	0
Reserved	Reserved	LGAIN5	LGAIN4	LGAIN3	LGAIN2	LGAIN1	LGAIN0

**6.16.1 ADC LEFT CHANNEL GAIN (LGAINX)**

*Default = 00h*

Function:

The level of the left analog channel can be adjusted in 1 dB increments as dictated by the Soft and Zero Cross bits (SZC[1:0]) from +15 to -15 dB. Levels are decoded in two's complement, as shown in [Table 17](#).

**6.17 ADC Right Channel Gain (address 1Dh)**

7	6	5	4	3	2	1	0
Reserved	Reserved	RGAIN5	RGAIN4	RGAIN3	RGAIN2	RGAIN1	RGAIN0

**6.17.1 ADC RIGHT CHANNEL GAIN (RGAINX)**

*Default = 00h*

Function:

The level of the right analog channel can be adjusted in 1 dB increments as dictated by the Soft and Zero Cross bits (SZC[1:0]) from +15 to -15 dB. Levels are decoded in two's complement, as shown in [Table 17](#).

Binary Code	Decimal Value	Volume Setting
001111	+15	+15 dB
001010	+10	+10 dB
000101	+5	+5 dB
000000	0	0 dB
111011	-5	-5 dB
110110	-10	-10 dB
110001	-15	-15 dB

**Table 17. Example ADC Input Gain Settings**

**6.18 Receiver Mode Control (address 1Eh)**

7	6	5	4	3	2	1	0
SP_SYNC	Reserved	DE-EMPH1	DE-EMPH0	INT1	INT0	HOLD1	HOLD0

**6.18.1 SERIAL PORT SYNCHRONIZATION (SP\_SYNC)**

*Default = 0*

*0 - CX & SAI Serial Port timings not in phase*

*1 - CX & SAI Serial Port timings are in phase*

Function:

Forces the LRCK and SCLK from the CX & SAI Serial Ports to align and operate in phase. This function will operate when both ports are running at the same sample rate or when operating at different sample rates.

**6.18.2 DE-EMPHASIS SELECT BITS (DE-EMPHX)**

*Default = 00*

*00 - Reserved*

*01 - De-Emphasis for 32 kHz sample rate.*

*10 - De-Emphasis for 44.1 kHz sample rate.*

*11 - De-Emphasis for 48 kHz sample rate.*

Function:

Used to specify which de-emphasis filter to apply when the “[Force PLL Lock \(FRC\\_PLL\\_LK\)](#)” on [page 53](#) is enabled.

**6.18.3 INTERRUPT PIN CONTROL (INTX)**

*Default = 00*

*00 - Active high; high output indicates interrupt condition has occurred*

*01 - Active low; low output indicates an interrupt condition has occurred*

*10 - Open drain, active low. Requires an external pull-up resistor on the INT pin.*

*11 - Reserved*

Function:

Determines how the interrupt pin (INT) will indicate an interrupt condition.

**6.18.4 AUDIO SAMPLE HOLD (HOLDX)**

*Default = 00*

*00 - Hold the last valid audio sample*

*01 - Replace the current audio sample with 00 (mute)*

*10 - Do not change the received audio sample*

*11 - Reserved*

Function:

Determines how received audio samples are affected when a receiver error occurs.

**6.19 Receiver Mode Control 2 (address 1Fh)**

7	6	5	4	3	2	1	0
Reserved	TMUX2	TMUX1	TMUX0	Reserved	RMUX2	RMUX1	RMUX0

**6.19.1 TXP MULTIPLEXER (TMUXX)**

Default = 000

Function:

Selects which of the eight receiver inputs will be mapped directly to the TXP output pin.

TMUX2	TMUX1	TMUX0	Description
0	0	0	Output from pin RXP0
0	0	1	Output from pin RXP1
0	1	0	Output from pin RXP2
0	1	1	Output from pin RXP3
1	0	0	Output from pin RXP4
1	0	1	Output from pin RXP5
1	1	0	Output from pin RXP6
1	1	1	Output from pin RXP7

Table 18. TXP Output Selection

**6.19.2 RECEIVER MULTIPLEXER (RMUXX)**

Default = 000

Function:

Selects which of the eight receiver inputs will be mapped to the internal receiver.

RMUX2	RMUX1	RMUX0	Description
0	0	0	Input from pin RXP0
0	0	1	Input from pin RXP1
0	1	0	Input from pin RXP2
0	1	1	Input from pin RXP3
1	0	0	Input from pin RXP4
1	0	1	Input from pin RXP5
1	1	0	Input from pin RXP6
1	1	1	Input from pin RXP7

Table 19. Receiver Input Selection

**6.20 Interrupt Status (address 20h) (Read Only)**

7	6	5	4	3	2	1	0
UNLOCK	Reserved	QCH	DETC	DETU	Reserved	OverFlow	RERR

For all bits in this register, a "1" means the associated interrupt condition has occurred at least once since the register was last read. A "0" means the associated interrupt condition has NOT occurred since the last reading of the register. Reading the register resets all bits to 0. Status bits that are masked off in the associated mask register will always be "0" in this register.

**6.20.1 PLL UNLOCK (UNLOCK)**

*Default = 0*

Function:

PLL unlock status bit. This bit will go high if the PLL becomes unlocked.

**6.20.2 NEW Q-SUBCODE BLOCK (QCH)**

*Default = 0*

Function:

Indicates when the Q-Subcode block has changed.

**6.20.3 D TO E C-BUFFER TRANSFER (DETC)**

*Default = 0*

Function:

Indicates when the channel status buffer has changed.

**6.20.4 D TO E U-BUFFER TRANSFER (DETU)**

*Default = 0*

Function:

Indicates when the user status buffer has changed.

**6.20.5 ADC OVERFLOW (OVERFLOW)**

*Default = 0*

Function:

Indicates that there is an over-range condition anywhere in the CS42526 ADC signal path.

**6.20.6 RECEIVER ERROR (RERR)**

*Default = 0*

Function:

Indicates that a receiver error has occurred. The register [“Receiver Errors \(address 26h\) \(Read Only\)” on page 67](#) may be read to determine the nature of the error which caused the interrupt.

**6.21 Interrupt Mask (address 21h)**

7	6	5	4	3	2	1	0
UNLOCKM	Reserved	QCHM	DETCM	DETUM	Reserved	OverFlowM	RERRM

*Default = 00000000*

Function:

The bits of this register serve as a mask for the interrupt sources found in the register [“Interrupt Status \(address 20h\) \(Read Only\)” on page 63](#). If a mask bit is set to 1, the error is unmasked, meaning that its occurrence will affect the INT pin and the status register. If a mask bit is set to 0, the error is masked, meaning that its occurrence will not affect the INT pin or the status register. The bit positions align with the corresponding bits in the Interrupt Status register.



## 6.22 Interrupt Mode MSB (address 22h) Interrupt Mode LSB (address 23h)

7	6	5	4	3	2	1	0
UNLOCK1	Reserved	QCH1	DETC1	DETU1	Reserved	OF1	RERR1
UNLOCK0	Reserved	QCH0	DETC0	DETU0	Reserved	OF0	RERR0

Default = 00000000

Function:

The two Interrupt Mode registers form a 2-bit code for each Interrupt Status register function. There are three ways to set the INT pin active in accordance with the interrupt condition. In the Rising edge active mode, the INT pin becomes active on the arrival of the interrupt condition. In the Falling edge active mode, the INT pin becomes active on the removal of the interrupt condition. In Level active mode, the INT interrupt pin becomes active during the interrupt condition. Be aware that the active level (Active High or Low) only depends on the INT[1:0] bits located in the register “Receiver Mode Control (address 1Eh)” on page 61.

- 00 - Rising edge active
- 01 - Falling edge active
- 10 - Level active
- 11 - Reserved

## 6.23 Channel Status Data Buffer Control (address 24h)

7	6	5	4	3	2	1	0
LOCKM1	LOCKM0	Reserved	Reserved	Reserved	BSEL	CAM	CHS

### 6.23.1 S/PDIF RECEIVER LOCKING MODE (LOCKMX)

Default = 01

00 - Revision C compatibility mode.

01 - Revision D default mode. Provides improved wideband jitter rejection in Double- and Quad-Speed modes.

10 - High update rate phase detector mode. Provides improved in-band jitter, but increased wideband jitter. Use this setting for best ADC and DAC performance with clocked from the PLL recovered clock.

11 - Reserved.

Function:

Selects the mode used by the S/PDIF receiver to lock to the active RXP[7:0] input. Revision C compatibility mode is included for backward compatibility with Revision C.

### 6.23.2 DATA BUFFER SELECT (BSEL)

Default = 0

0 - Data buffer address space contains Channel Status data

1 - Data buffer address space contains User data

Function:

Selects the data buffer register addresses to contain either User data or Channel Status data.

**6.23.3 C-DATA BUFFER CONTROL (CAM)**

*Default = 0*

*0 - One byte mode*

*1 - Two byte mode*

Function:

Sets the C-data buffer control port access mode.

**6.23.4 CHANNEL SELECT (CHS)**

*Default = 0*

Function:

When set to '0', channel A information is displayed in the receiver channel status register. Channel A information is output during control port reads when CAM is set to '0' (one byte mode).

When set to '1', channel B information is displayed in the receiver channel status register. Channel B information is output during control port reads when CAM is set to '0' (one byte mode).

**6.24 Receiver Channel Status (address 25h) (Read Only)**

<b>7</b>	<b>6</b>	<b>5</b>	<b>4</b>	<b>3</b>	<b>2</b>	<b>1</b>	<b>0</b>
AUX3	AUX2	AUX1	AUX0	PRO	AUDIO	COPY	ORIG

The bits in this register can be associated with either channel A or B of the received data. The desired channel is selected with the CHS bit of the Channel Status Data Buffer Control register.

**6.24.1 AUXILIARY DATA WIDTH (AUXX)**

*Default = xxxx*

Function:

Displays the incoming auxiliary data field width, as indicated by the incoming channel status bits, decoded according to IEC60958.

<b>AUX3</b>	<b>AUX2</b>	<b>AUX1</b>	<b>AUX0</b>	<b>Description</b>
0	0	0	0	Auxiliary data is not present
0	0	0	1	Auxiliary data is 1 bit long
0	0	1	0	Auxiliary data is 2 bit long
0	0	1	1	Auxiliary data is 3 bit long
0	1	0	0	Auxiliary data is 4 bit long
0	1	0	1	Auxiliary data is 5 bit long
0	1	1	0	Auxiliary data is 6 bit long
0	1	1	1	Auxiliary data is 7 bit long
1	0	0	0	Auxiliary data is 8 bit long
1	0	0	1	1001 - 1111 is Reserved

**Table 20. Auxiliary Data Width Selection**

**6.24.2 CHANNEL STATUS BLOCK FORMAT (PRO)**

Default = x

Function:

Indicates the channel status block format.

**6.24.3 AUDIO INDICATOR (AUDIO)**

Default = x

Function:

A '0' indicates that the received data is linearly coded PCM audio. A '1' indicates that the received data is not linearly coded PCM audio.

**6.24.4 SCMS COPYRIGHT (COPY)**

Default = x

Function:

A '0' indicates that copyright is not asserted, while a '1' indicates that copyright is asserted. If the category code is set to General in the incoming S/PDIF digital stream, copyright will always be indicated by COPY, even when the stream indicates no copyright.

**6.24.5 SCMS GENERATION (ORIG)**

Default = x

Function:

A '0' indicates that the received data is 1st generation or higher. A '1' indicates that the received data is original. COPY and ORIG will both be set to '1' if the incoming data is flagged as professional, or if the receiver is not in use.

**6.25 Receiver Errors (address 26h) (Read Only)**

7	6	5	4	3	2	1	0
Reserved	QCRC	CCRC	UNLOCK	V	CONF	BIP	PAR

**6.25.1 CRC ERROR (QCRC)**

Default = x

0 - No error

1 - Error

Function:

Indicates a Q-subcode data CRC error. This bit is updated on Q-subcode block boundaries.

**6.25.2 REDUNDANCY CHECK (CCRC)**

Default = x

0 - No error

1 - Error

Function:

Indicates a channel status block cyclic redundancy. This bit is updated on CS block boundaries, valid in Professional mode.

**6.25.3 PLL LOCK STATUS (UNLOCK)**

*Default = x*  
*0 - PLL locked*  
*1 - PLL out of lock*  
 Function:

Indicates the lock status of the PLL.

**6.25.4 RECEIVED VALIDITY (V)**

*Default = x*  
*0 - Data is valid and is normally linear coded PCM audio*  
*1 - Data is invalid, or may be valid compressed audio*  
 Function:

Indicates the received validity status. This bit is updated on sub-frame boundaries.

**6.25.5 RECEIVED CONFIDENCE (CONF)**

*Default = x*  
*0 - No error*  
*1 - Confidence error. The logical OR of UNLOCK and BIP. The input data stream may be near an error condition due to jitter.*  
 Function:

Indicates the received confidence status. This bit is updated on sub-frame boundaries.

**6.25.6 BI-PHASE ERROR (BIP)**

*Default = x*  
*0 - No error*  
*1 - Bi-phase error. This indicates an error in the received bi-phase coding.*  
 Function:

Indicates a bi-phase coding error. This bit is updated on sub-frame boundaries.

**6.25.7 PARITY STATUS (PAR)**

*Default = x*  
*0 - No error*  
*1 - Parity Error*  
 Function:

Indicates the Parity status. This bit is updated on sub-frame boundaries.

**6.26 Receiver Errors Mask (address 27h)**

7	6	5	4	3	2	1	0
Reserved	QCRCM	CCRCM	UNLOCKM	VM	CONFM	BIPM	PARM

*Default = 00000000*  
 Function:

The bits in this register serve as masks for the corresponding bits of the Receiver Errors register. If a mask bit is set to 1, the error is unmasked, meaning that its occurrence will appear in the receiver errors register, will affect the RERR interrupt, and will affect the current audio sample according to

the status of the HOLD bit. If a mask bit is set to 0, the error is masked, meaning that its occurrence will not appear in the receiver error register, will not affect the RERR interrupt, and will not affect the current audio sample. The CCRC and QCRC bits behave differently from the other bits: they do not affect the current audio sample even when unmasked.

## 6.27 Mutec Pin Control (address 28h)

7	6	5	4	3	2	1	0
Reserved	Reserved	MCPolarity	M_AOUTA1	M_AOUTB1	M_AOUTA2 M_AOUTB2	M_AOUTA3 M_AOUTB3	Reserved

### 6.27.1 MUTE POLARITY SELECT (MCPOLARITY)

*Default = 0*

*0 - Active low*

*1 - Active high*

Function:

Determines the polarity of the MUTE pin.

### 6.27.2 CHANNEL MUTES SELECT (M\_AOUTXX)

*Default = 1111*

*0 - Channel mute is not mapped to the MUTE pin*

*1 - Channel mute is mapped to the MUTE pin*

Function:

Determines which channel mutes will be mapped to the MUTE pin. If no channel mute bits are mapped, then the MUTE pin is driven to the “active” state as defined by the POLARITY bit. These Channel Mute Select bits are “ANDed” together in order for the MUTE pin to go active. This means that if multiple Channel Mutes are selected to be mapped to the MUTE pin, all corresponding channels must be muted before the MUTE pin will go active.

## 6.28 RXP/General-Purpose Pin Control (addresses 29h to 2Fh)

7	6	5	4	3	2	1	0
Mode1	Mode0	Polarity	Function4	Function3	Function2	Function1	Function0

### 6.28.1 MODE CONTROL (MODEX)

*Default = 00*

*00 - RXP Input*

*01 - Mute Mode*

*10 - GPO/Overflow Mode*

*11 - GPO, Drive High Mode*

Function:

RXP Input - The pin is configured as a receiver input which can then be muxed to either the TXP pin or to the internal receiver.

Mute Mode - The pin is configured as a dedicated mute pin. The muting function is controlled by the Function bits.

GPO, Drive Low / ADC Overflow Mode - The pin is configured as a general-purpose output driven low

or as a dedicated ADC overflow pin indicating an over-range condition anywhere in the ADC signal path for either the left or right channel. The Functionx bits determine the operation of the pin. When configured as a GPO with the output driven low, the driver is a CMOS driver. When configured to identify an ADC Overflow condition, the driver is an open drain driver requiring a pull-up resistor.

GPO, Drive High Mode - The pin is configured as a general purpose output driven high.

### 6.28.2 POLARITY SELECT (POLARITY)

*Default = 0*

Function:

RXP Input - If the pin is configured for an RXP input, the polarity bit is ignored. It is recommended that in this mode this bit be set to 0.

Mute Mode - If the pin is configured as a dedicated mute output pin, the polarity bit determines the polarity of the mapped pin according to the following

*0 - Active low*

*1 - Active high*

GPO, Drive Low / ADC Overflow Mode - If the pin is configured as a GPO, Drive Low / ADC Overflow Mode pin, the polarity bit is ignored. It is recommended that in this mode this bit be set to 0.

GPO, Drive High - If the pin is configured as a general-purpose output driven high, the polarity bit is ignored. It is recommended that in this mode this bit be set to 0.

### 6.28.3 FUNCTIONAL CONTROL (FUNCTIONX)

*Default = 00000*

Function:

RXP Input - If the pin is configured for an RXP input, the functional bits are ignored. It is recommended that in this mode all the functional bits be set to 0.

Mute Mode - If the pin is configured as a dedicated mute pin, the functional bits determine which channel mutes will be mapped to this pin according to the following table.

*0 - Channel mute is not mapped to the RXPx/GPOx pin*

*1 - Channel mute is mapped to the RXPx/GPOx pin:*

RXPx/GPOx	Reg Address	Function4	Function3	Function2	Function1	Function0
RXP7/GPO7 pin 42	29h	M_AOUTA1	M_AOUTB1	M_AOUTA2 M_AOUTB2	M_AOUTA3 M_AOUTB3	Reserved
RXP6/GPO6 pin 43	2Ah	M_AOUTA1 M_AOUTB1	M_AOUTA2	M_AOUTB2	M_AOUTA3 M_AOUTB3	Reserved
RXP5/GPO5 pin 44	2Bh	M_AOUTA1 M_AOUTB1	M_AOUTA2	M_AOUTB2	M_AOUTA3 M_AOUTB3	Reserved
RXP4/GPO4 pin 45	2Ch	M_AOUTA1 M_AOUTB1	M_AOUTA2 M_AOUTB2	M_AOUTA3	M_AOUTB3	Reserved
RXP3/GPO3 pin 46	2Dh	M_AOUTA1 M_AOUTB1	M_AOUTA2 M_AOUTB2	M_AOUTA3	M_AOUTB3	Reserved
RXP2/GPO2 pin 47	2Eh	M_AOUTA1 M_AOUTB1	M_AOUTA2 M_AOUTB2	M_AOUTA3 M_AOUTB3	Reserved	Reserved
RXP1/GPO1 pin 48	2Fh	M_AOUTA1 M_AOUTB1	M_AOUTA2 M_AOUTB2	M_AOUTA3 M_AOUTB3	Reserved	Reserved

GPO, Drive Low / ADC Overflow Mode - If the pin is configured as a GPO, Drive Low / ADC Overflow Mode pin, the Function1 and Function0 bits determine how the output will behave according to the

following table. It is recommended that in this mode the remaining functional bits be set to 0.

Function1	Function0	GPOx	Driver Type
0	0	Drive Low	CMOS
1	1	OVFL R or L	Open Drain

**GPO, Drive High** - If the pin is configured as a general-purpose output, the functional bits are ignored and the pin is driven high. It is recommended that in this mode all the functional bits be set to 0.

### 6.29 Q-Channel Subcode Bytes 0 to 9 (addresses 30h to 39h) (Read Only)

7	6	5	4	3	2	1	0
Address3	Address2	Address1	Address0	Control3	Control2	Control1	Control0
Track7	Track6	Track5	Track4	Track3	Track2	Track1	Track0
Index7	Index6	Index5	Index4	Index3	Index2	Index1	Index0
Minute7	Minute6	Minute5	Minute4	Minute3	Minute2	Minute1	Minute0
Second7	Second6	Second5	Second4	Second3	Second2	Second1	Second0
Frame7	Frame6	Frame5	Frame4	Frame3	Frame2	Frame1	Frame0
Zero7	Zero6	Zero5	Zero4	Zero3	Zero2	Zero1	Zero0
A.Minute7	A.Minute6	A.Minute5	A.Minute4	A.Minute3	A.Minute2	A.Minute1	A.Minute0
A.Second7	A.Second6	A.Second5	A.Second4	A.Second3	A.Second2	A.Second1	A.Second0
A.Frame7	A.Frame6	A.Frame5	A.Frame4	A.Frame3	A.Frame2	A.Frame1	A.Frame0

These ten registers contain the decoded Q-channel subcode data.

### 6.30 C-Bit or U-Bit Data Buffer (addresses 3Ah to 51h) (Read Only)

7	6	5	4	3	2	1	0
CU Buffer7	CU Buffer6	CU Buffer5	CU Buffer4	CU Buffer3	CU Buffer2	CU Buffer1	CU Buffer0

Either channel status data buffer E or user data buffer E is accessible through these register addresses.

## **7. PARAMETER DEFINITIONS**

### **Dynamic Range**

The ratio of the rms value of the signal to the rms sum of all other spectral components over the specified bandwidth. Dynamic Range is a signal-to-noise ratio measurement over the specified band width made with a -60 dBFS signal. 60 dB is added to resulting measurement to refer the measurement to full-scale. This technique ensures that the distortion components are below the noise level and do not effect the measurement. This measurement technique has been accepted by the Audio Engineering Society, AES17-1991, and the Electronic Industries Association of Japan, EIAJ CP-307. Expressed in decibels.

### **Total Harmonic Distortion + Noise**

The ratio of the rms value of the signal to the rms sum of all other spectral components over the specified band width (typically 10 Hz to 20 kHz), including distortion components. Expressed in decibels. Measured at -1 and -20 dBFS as suggested in AES17-1991 Annex A.

### **Frequency Response**

A measure of the amplitude response variation from 10 Hz to 20 kHz relative to the amplitude response at 1 kHz. Units in decibels.

### **Interchannel Isolation**

A measure of crosstalk between the left and right channels. Measured for each channel at the converter's output with no signal to the input under test and a full-scale signal applied to the other channel. Units in decibels.

### **Interchannel Gain Mismatch**

The gain difference between left and right channels. Units in decibels.

### **Gain Error**

The deviation from the nominal full-scale analog output for a full-scale digital input.

### **Gain Drift**

The change in gain value with temperature. Units in ppm/°C.

### **Offset Error**

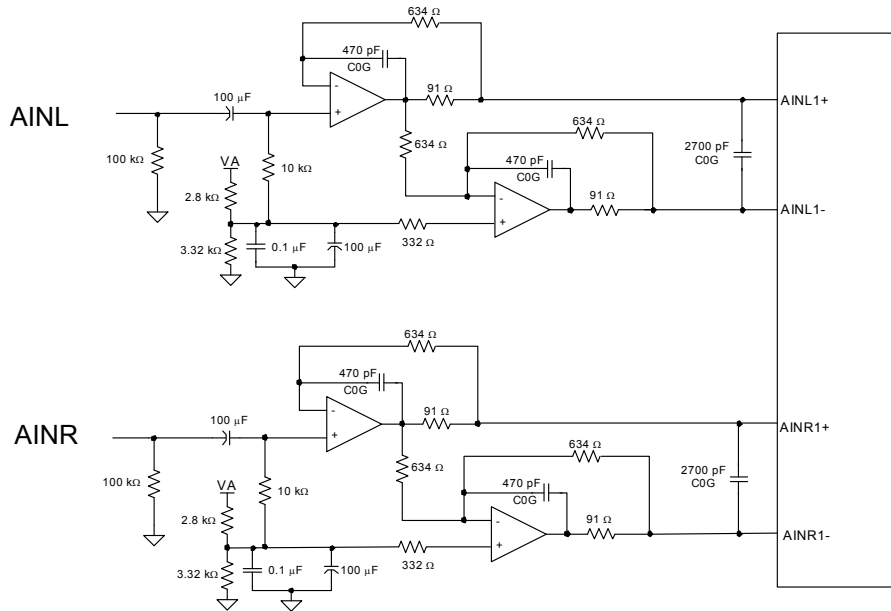
The deviation of the mid-scale transition (111...111 to 000...000) from the ideal. Units in mV.



## 8. APPENDIX A: EXTERNAL FILTERS

### 8.1 ADC Input Filter

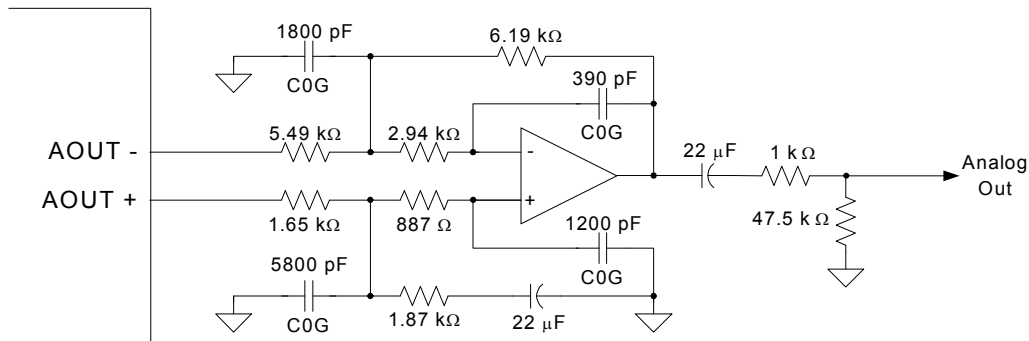
The analog modulator samples the input at 6.144 MHz (internal MCLK=12.288 MHz). The digital filter will reject signals within the stopband of the filter. However, there is no rejection for input signals which are  $(n \times 6.144 \text{ MHz})$  the digital passband frequency, where  $n=0,1,2,\dots$  Refer to [Figure 24](#) for a recommended analog input buffer that will attenuate any noise energy at 6.144 MHz, in addition to providing the optimum source impedance for the modulators. The use of capacitors that have a large voltage coefficient (such as general-purpose ceramics) must be avoided since these can degrade signal linearity.



**Figure 24. Recommended Analog Input Buffer**

### 8.2 DAC Output Filter

The CS42526 is a linear phase design and does not include phase or amplitude compensation for an external filter. Therefore, the DAC system phase and amplitude response will be dependent on the external analog circuitry.



**Figure 25. Recommended Analog Output Buffer**

## 9. APPENDIX B: S/PDIF RECEIVER

### 9.1 Error Reporting and Hold Function

The UNLOCK bit indicates whether the PLL is locked to the incoming S/PDIF data. The V bit reflects the current validity bit status. The CONF (Confidence) bit indicates the amplitude of the eye pattern opening, indicating a link that is close to generating errors. The BIP (Bi-Phase) error bit indicates an error in incoming bi-phase coding. The PAR (Parity) bit indicates a received parity error.

The error bits are “sticky”, meaning they are set on the first occurrence of the associated error and will remain set until the user reads the register through the control port. This enables the register to log all unmasked errors that occurred since the last time the register was read.

The Receiver Errors Mask register (See [“Receiver Errors Mask \(address 27h\)” on page 68](#)) allows masking of individual errors. The bits in this register serve as masks for the corresponding bits of the Receiver Error Register. If a mask bit is set to 1, the error is unmasked, which implies the following: its occurrence will be reported in the receiver error register, invoke the occurrence of a RERR interrupt, and affect the current audio sample according to the status of the HOLD bits. The HOLD bits allow a choice of holding the previous sample, replacing the current sample with zero (mute), or not changing the current audio sample. If a mask bit is set to 0, the error is masked, which implies the following: its occurrence will not be reported in the receiver error register, the RERR interrupt will not be generated, and the current audio sample will not be affected. The QCRC and CCRC errors do not affect the current audio sample, even if unmasked.

### 9.2 Channel Status Data Handling

The setting of the CHS bit in the register [“Channel Status Data Buffer Control \(address 24h\)” on page 65](#) determines whether the channel status decodes are from the A channel (CHS = 0) or B channel (CHS = 1).

The PRO (professional) bit is extracted directly. For consumer data, the COPY (copyright) bit is extracted, and the category code and L bits are decoded to determine SCMS status, indicated by the ORIG (original) bit. If the category code is set to General on the incoming S/PDIF stream, copyright will always be indicated even when the stream indicates no copyright. Finally, the AUDIO bit is extracted and used to set an AUDIO indicator, as described in section [4.4.5, Non-Audio Auto-Detection](#).

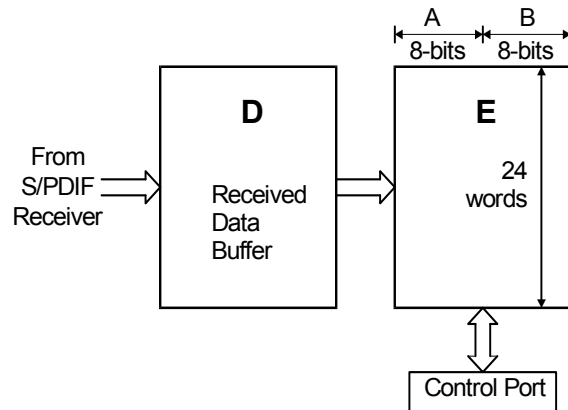
If 50/15  $\mu$ s pre-emphasis is detected, and the Receiver Auto De-emphasis control is enabled, then de-emphasis will automatically be applied to the incoming digital PCM data. See [“Functional Mode \(address 03h\)” on page 47](#) for more details.

The encoded channel status bits which indicate sample word length are decoded according to IEC 60958. Audio data routed to the Serial Audio Interface port is unaffected by the word length settings; all 24 bits are passed on as received.

The CS42526 also contains sufficient RAM to store a full block of C data for both A and B channels ( $192 \times 2 = 384$  bits), and also 384 bits of User (U data) information. The user may read from these buffer RAMs through the control port.

The buffering scheme involves two block-sized buffers, named D and E, as shown in [Figure 26](#). The MSB of each byte represents the first bit in the serial C data stream. For example, the MSB of byte 0 (which is at control port address 4Ah) is the consumer/professional bit for channel status block A.

The first buffer (D) accepts incoming C data from the S/PDIF receiver. The 2nd buffer (E) accepts entire blocks of data from the D buffer. The E buffer is also accessible from the control port, allowing reading of the C data.



**Figure 26. Channel Status Data Buffer Structure**

## 9.2.1 Channel Status Data E Buffer Access

The user can monitor the incoming Channel Status data by reading the E buffer, which is mapped into the register space of the CS42526 through the control port Data Buffer. The Data Buffer must first be configured to point to the address space of the C data. This is accomplished by setting the BSEL bit to '0' in the register [“Channel Status Data Buffer Control \(address 24h\)”](#) on page 65.

The user can configure the Interrupt Mask Register to cause an interrupt whenever any data-bit changes are detected when D to E Channel Status buffer transfers occur. If no data bits have changed within the current transfer of data from D to E, no interrupt will be generated. This allows determination of the acceptable time periods to interact with the E buffer. See [“Interrupt Mask \(address 21h\)”](#) on page 64 for more details.

The E buffer is organized as 24 x 16-bit words. For each word the MS Byte is the A channel data, and the LS Byte is the B channel data (see [Figure 26](#)). There are two methods of accessing this memory, known as One-Byte Mode and Two-Byte Mode. The desired mode is selected by setting the CAM bit in the Channel Status Data Buffer Control Register.

### 9.2.1.1 One-Byte Mode

In many applications, the channel status blocks for the A and B channels will be identical. In this situation, the user may read a byte from one of the channel's blocks since the corresponding byte for the other channel will likely be the same. One-Byte Mode takes advantage of the often identical nature of A and B channel status data. When reading data in One-Byte Mode, a single byte is returned, which can be from channel A or B data, depending on a register control bit.

One-Byte Mode saves the user substantial control port access time, as it effectively accesses two bytes worth of information in 1 byte's worth of access time. If the control port's auto-increment addressing is used in combination with this mode, multi-byte accesses, such as full-block reads, can be done especially efficiently.

### 9.2.1.2 Two-Byte Mode

There are those applications in which the A and B channel status blocks will not be the same, and the user is interested in accessing both blocks. In these situations, Two-Byte Mode should be used to access the E buffer.

In this mode, a read will cause the CS42526 to output two bytes from its control port. The first byte out will represent the A channel status data, and the second byte will represent the B channel status data.

### 9.2.2 Serial Copy Management System (SCMS)

The CS42526 allows read access to all the channel status bits. For consumer mode SCMS compliance, the host microcontroller needs to read and interpret the Category Code, Copy bit and L bit appropriately.

## 9.3 User (U) Data E Buffer Access

Entire blocks of U data are buffered using a cascade of two block-sized RAMs to perform the buffering as described in the Channel Status section. The user has access to the E buffer through the control port Data Buffer which is mapped into the register space of the CS42526. The Data Buffer must first be configured to point to the address space of the U data. This is accomplished by setting the BSEL bit to '1' in the register "Channel Status Data Buffer Control (address 24h)" on page 65.

The user can configure the Interrupt Mask Register to cause an interrupt whenever any data bit changes are detected when D to E Channel Status buffer transfers occur. If no data bits have changed within the current transfer of data from D to E, no interrupt will be generated. This allows determination of the acceptable time periods to interact with the E buffer. See "Interrupt Mask (address 21h)" on page 64 for more details.

The U buffer access only operates in Two-Byte Mode, since there is no concept of A and B blocks for user data. The arrangement of the data is as follows: Bit15[A7]Bit14[B7]Bit13[A6]Bit12[B6]...Bit1[A0]Bit0[B0]. The arrangement of the data in each byte is as follows: MSB is the first received bit and is the first transmitted bit. The first byte read is the first byte received, and the first byte sent is the first byte transmitted. When two bytes are read from the E buffer, the bits are presented in the following arrangement: A[7]B[7]A[6]B[6]....A[0]B[0].

### 9.3.1 Non-Audio Auto-Detection

The CS42526 S/PDIF receiver can detect non-audio data originating from AC-3 or MPEG encoders. This is accomplished by looking for a 96-bit sync code, consisting of 0x0000, 0x0000, 0x0000, 0x0000, 0xF872, and 0x4E1F. When the sync code is detected, an internal AUTODETECT signal will be asserted. If no additional sync codes are detected within the next 4096 frames, AUTODETECT will be de-asserted until another sync code is detected. The AUDIO bit in the Receiver Channel Status register is the logical OR of AUTODETECT and the received channel status bit 1. If non-audio data is detected, the data will be processed exactly as if it were normal audio. It is up to the user to mute the outputs as required.

#### 9.3.1.1 Format Detection

The CS42526 can automatically detect various serial audio input formats. The Receiver Status register (08h) is used to indicate a detected format. The register will indicate if uncompressed PCM data, IEC61937 data, DTS-LD data, DTS-CD data, HDCD data, or digital silence was detected. Additionally, the IEC61937 Pc/Pd burst preambles are available in registers 09h-0Ch. See the register descriptions for more information.

## 10. APPENDIX C: PLL FILTER

The PLL has been designed to only use the preambles of the S/PDIF stream to provide lock update information to the PLL. This results in the PLL being immune to data-dependent jitter effects because the S/PDIF preambles do not vary with the data.

The PLL has the ability to lock onto a wide range of input sample rates with no external component changes. The nominal center sample rate is the sample rate that the PLL first locks onto upon application of an S/PDIF data stream.

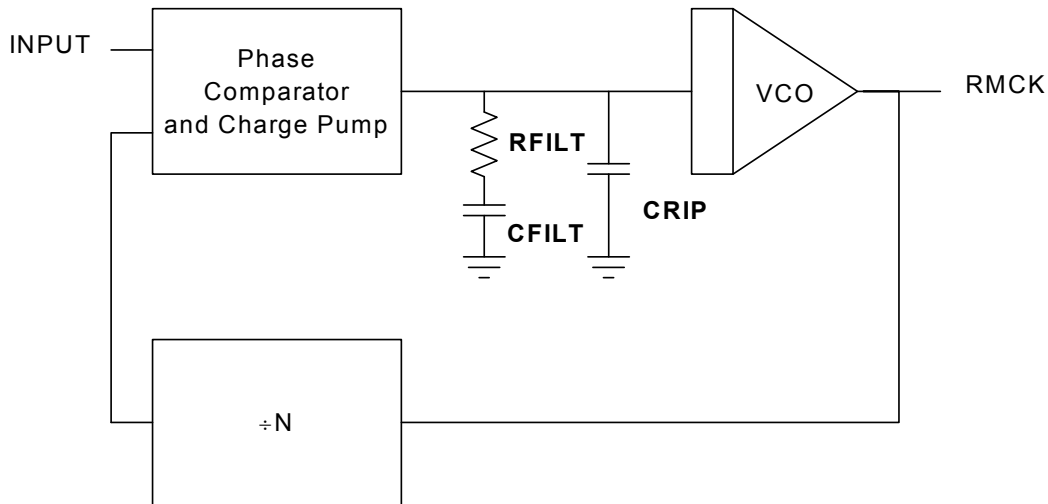


Figure 27. PLL Block Diagram

### 10.1 External Filter Components

#### 10.1.1 General

The PLL behavior is affected by the external filter component values and the locking mode as configured by the LOCKM[1:0] bits in register 24h. [Table 21](#) shows the supported configurations of PLL component values and their associated locking modes.

	Rfilt (kΩ)	CFilt (μF)	CRIP (pF)	LOCKM[1:0]	Notes
Configuration 1	2.55	0.047	2200	00	Used for backward compatibility with Revision C devices.
Configuration 2	2.55	0.047	2200	01	Default configuration for Revision D devices. Provides improved wideband jitter rejection in Double- and Quad-Speed modes.
Configuration 3	1.37	0.022	1000	10	Provides improved in-band jitter rejection, with increased wideband jitter. Use this configuration for best DAC and ADC performance when clocked from the PLL recovered clock.

Table 21. External PLL Component Values & Locking Modes

The external PLL component values listed in [Table 21](#) have a high corner-frequency jitter-attenuation curve, take a short time to lock, and offer good output jitter performance. It should be noted that the PLL component values shown must be used with their associated locking modes as shown in [Table 21](#). Use of any other combinations of component values and locking modes may result in unstable PLL behavior.

Configuration 1 may be used for hardware and software backward-compatibility for designs originally made with the CS42526 Revision C.

Configuration 2 may be used for hardware-only backward-compatibility for designs originally made with the CS42526 Revision C. Using the Revision D default locking mode of '01' will provide improved wide-band jitter rejection in Double- and Quad-Speed modes.

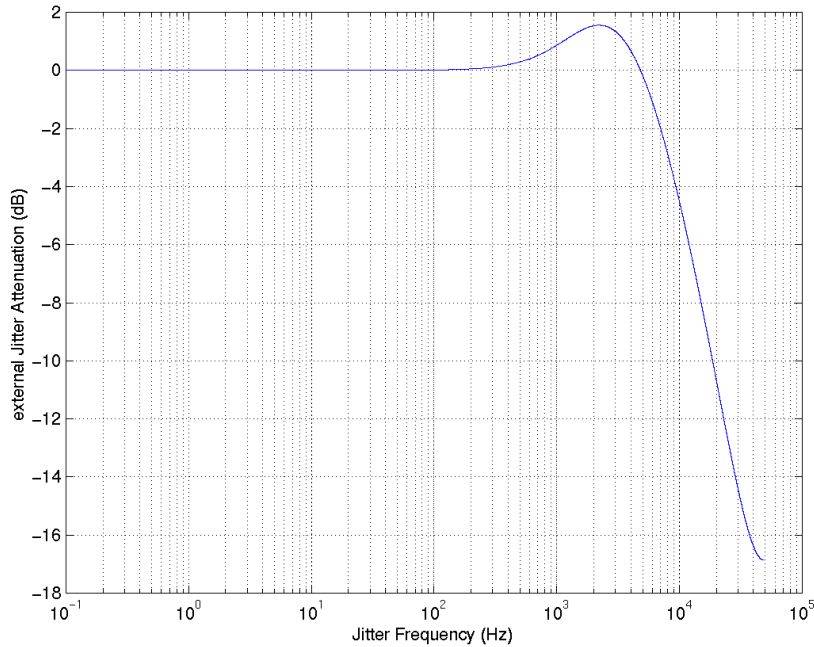
Configuration 3 may be used for new designs with the CS42526 Revision D, or for existing designs in which the hardware and software may be changed to use the specified PLL component values and LOCKM[1:0] register setting. This configuration provides the best DAC and ADC performance when clocked from the PLL recovered clock.

The Typical Connection Diagram, [Figure 5](#) shows the recommended configuration of the two capacitors and one resistor that comprise the PLL filter. It is important to treat the LPFILT pin as a low-level analog input. It is suggested that the ground end of the PLL filter be returned directly to the AGND pin independently of the digital ground plane.

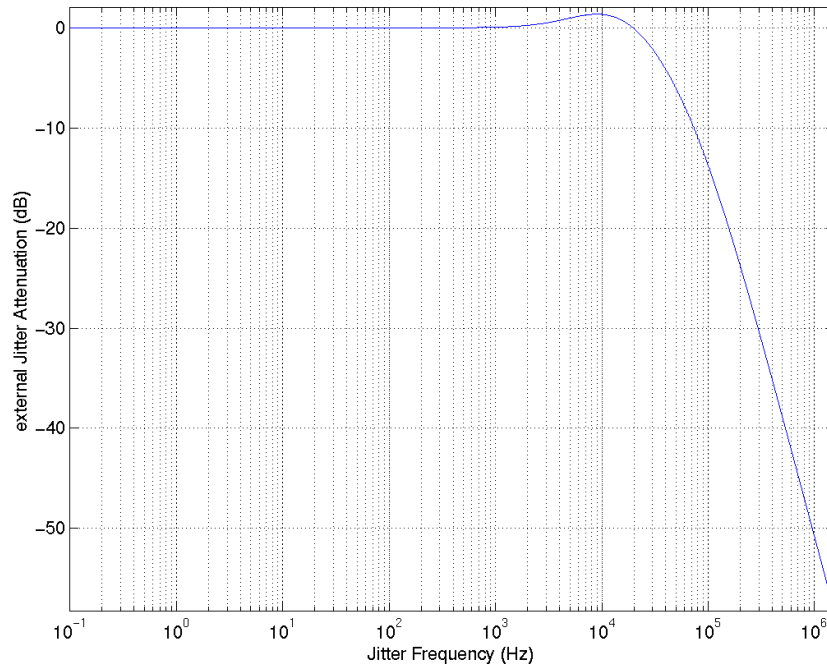
### 10.1.2 Jitter Attenuation

Figures 28 and 29 show the jitter-attenuation characteristics for the 32-192 kHz sample rate range when used with the external PLL component values and locking modes as specified in Table 21.

The AES3 and IEC60958-4 specifications do not have allowances for locking to sample rates less than 32 kHz or for locking to the SAI\_LRCK input. These specifications state a maximum of 2 dB jitter gain or peaking.



**Figure 28. Jitter-Attenuation Characteristics of PLL - Configurations 1 & 2**



**Figure 29. Jitter-Attenuation Characteristics of PLL - Configuration 3**

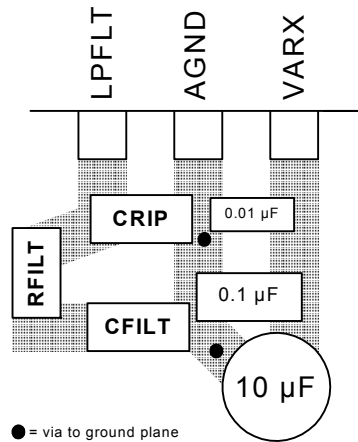
### 10.1.3 Capacitor Selection

The type of capacitors used for the PLL filter can have a significant effect on receiver performance. Large or exotic film capacitors are not necessary because their leads, and the required longer circuit board traces, add undesirable inductance to the circuit. Surface-mount ceramic capacitors are a good choice because their own inductance is low, and they can be mounted close to the LPFLT pin to minimize trace inductance. For CRIP, a C0G or NPO dielectric is recommended; and for CFILT, an X7R dielectric is preferred. Avoid capacitors with large temperature co-efficient, or capacitors with high dielectric constants, that are sensitive to shock and vibration. These include the Z5U and Y5V dielectrics.



### 10.1.4 Circuit Board Layout

Board layout and capacitor choice affect each other and determine the performance of the PLL. Figure 30 illustrates a suggested layout for the PLL filter components and for bypassing the analog supply voltage. The 10  $\mu\text{F}$  bypass capacitor is an electrolytic in a surface-mount case A or thru-hole package. RFILT, CFILT, CRIP, and the 0.1  $\mu\text{F}$  decoupling capacitor are in an 0805 form factor. The 0.01  $\mu\text{F}$  decoupling capacitor is in the 0603 form factor. The traces are on the top surface of the board with the IC so that there is no via inductance. The traces themselves are short to minimize the inductance in the filter path. The VARX and AGND traces extend back to their origin and are shown only in truncated form in the drawing.



**Figure 30. Recommended Layout Example**

## 11.APPENDIX D: EXTERNAL AES3-S/PDIF-IEC60958 RECEIVER COMPONENTS

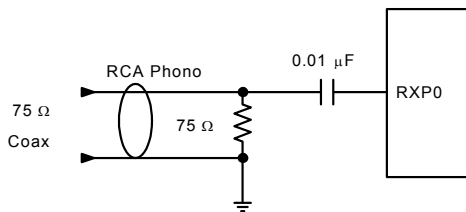
### 11.1 AES3 Receiver External Components

The CS42526 AES3 receiver is designed to accept only consumer-standard interfaces. The standards call for an unbalanced circuit having a receiver impedance of  $75\ \Omega \pm 5\%$ . The connector is an RCA phono socket. The receiver circuit is shown in Figure 31. Figure 32 shows an implementation of the Input S/PDIF Multiplexer using the consumer interface.

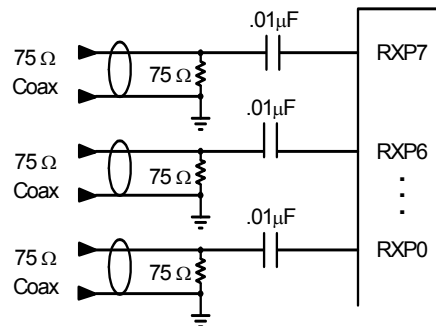
In the configuration of systems, it is important to avoid ground loops and DC current flowing down the shield of the cable that could result when boxes with different ground potentials are connected. Generally, it is good practice to ground the shield to the chassis of the transmitting unit and connect the shield through a capacitor to chassis ground at the receiver. However, in some cases, it is advantageous to have the ground of two boxes held at the same potential and make the electrical connection through the cable shield. Generally, it may be a good idea to provide the option of grounding or capacitively coupling the shield to the chassis.

When more than one RXP pin is driven simultaneously, as shown in Figure 32, there is a potential for crosstalk between inputs. To minimize this crosstalk, provide as much trace separation as is reasonable and choose non-adjacent inputs when possible.

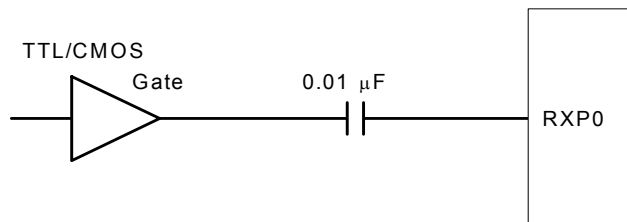
The circuit shown in Figure 33 may be used when external RS422 receivers, optical receivers or other TTL/CMOS logic outputs drive the CS42526 receiver input.



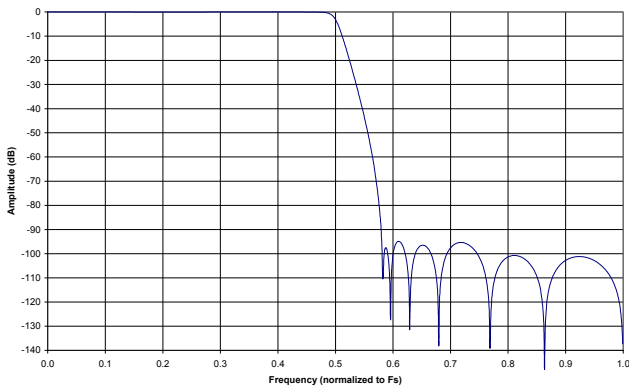
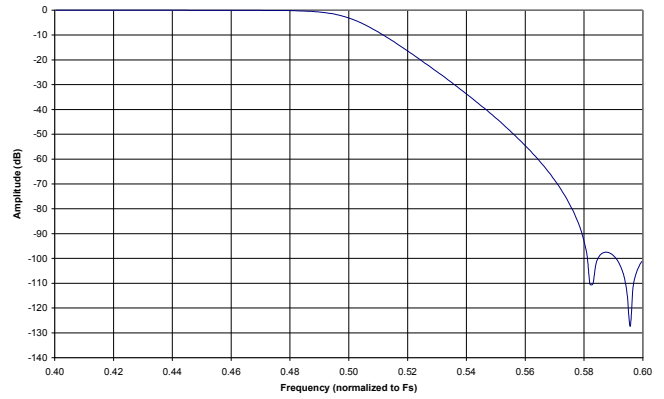
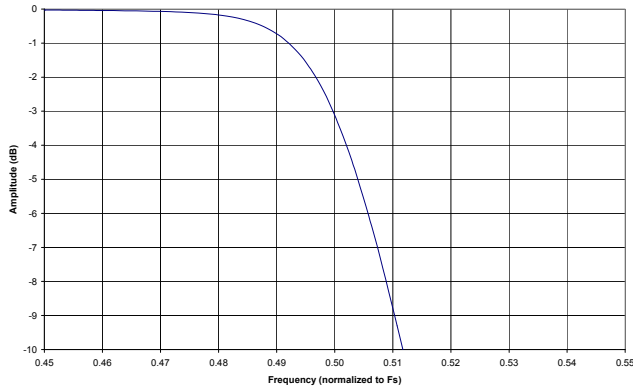
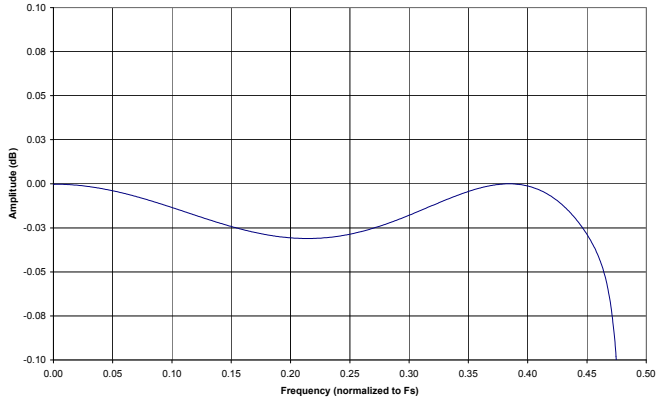
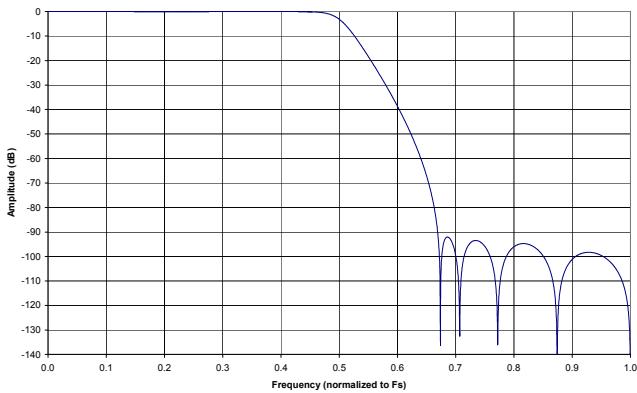
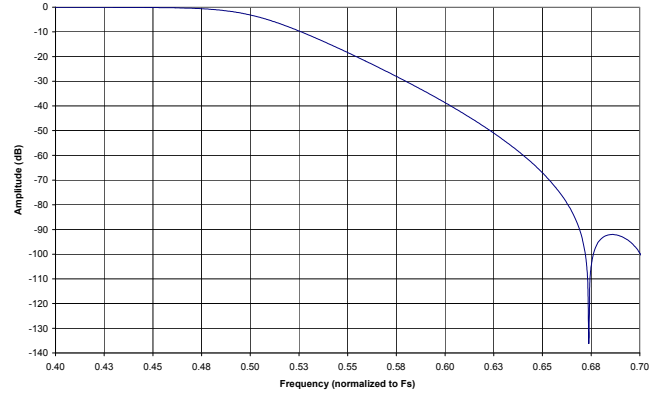
**Figure 31. Consumer Input Circuit**

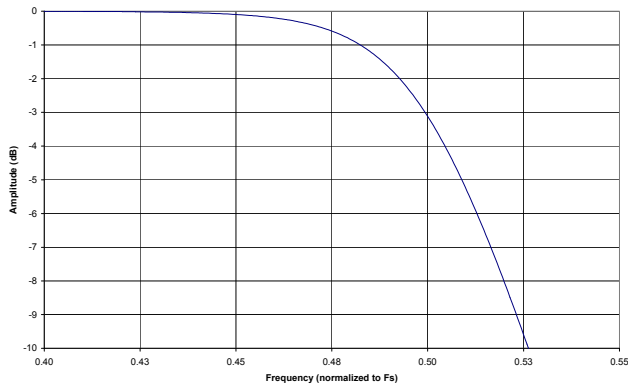
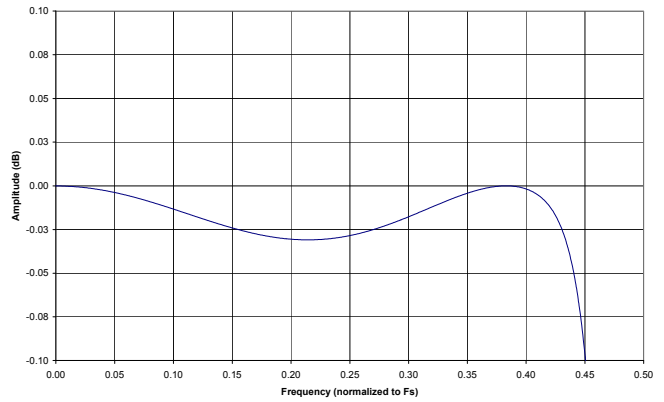
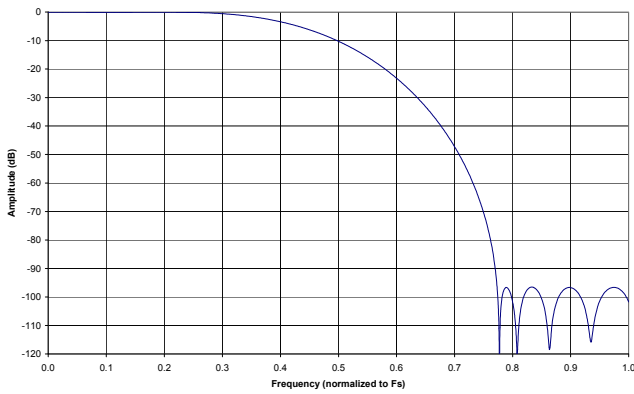
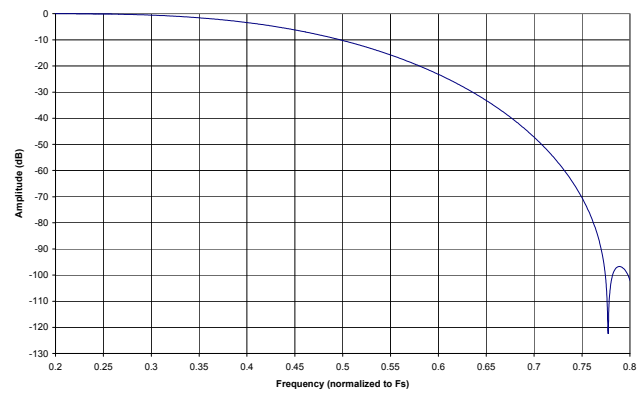
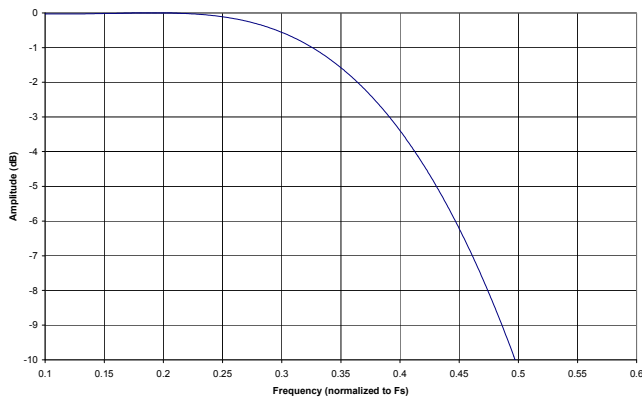
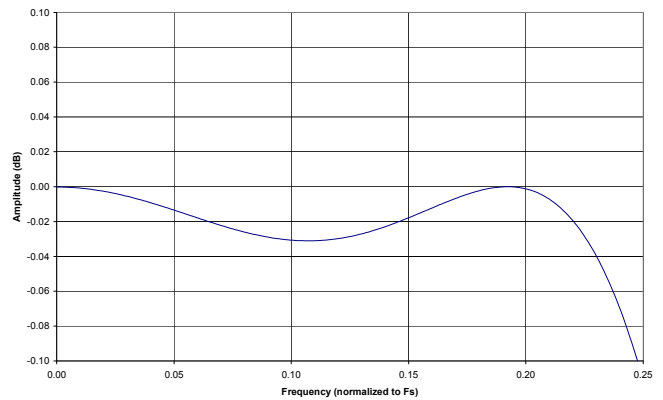


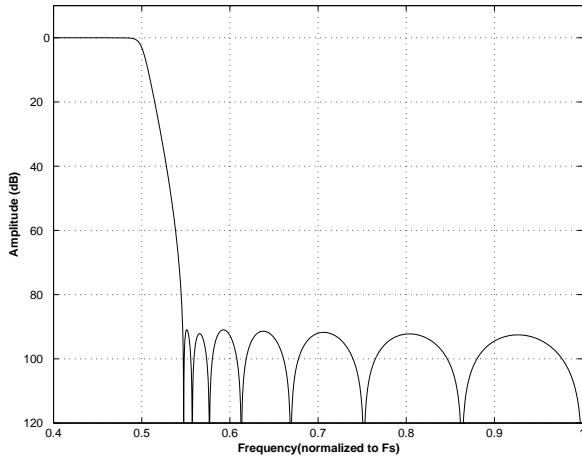
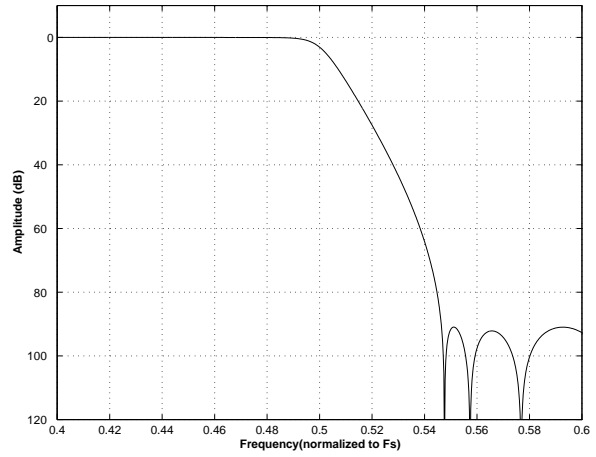
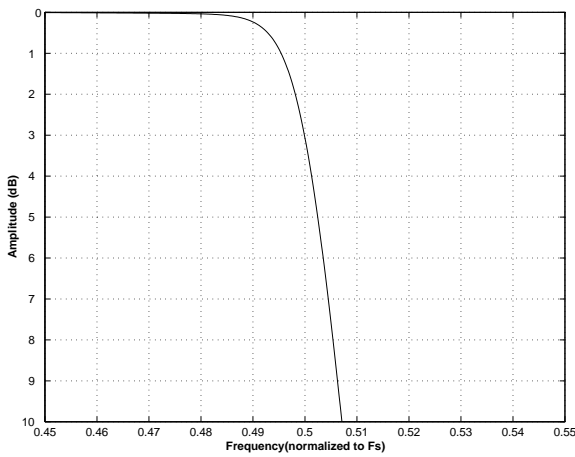
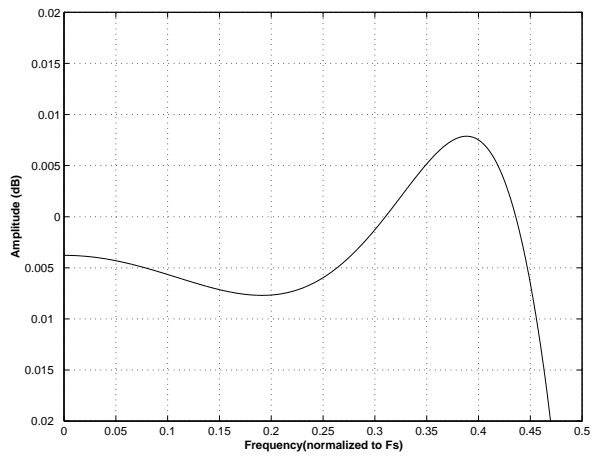
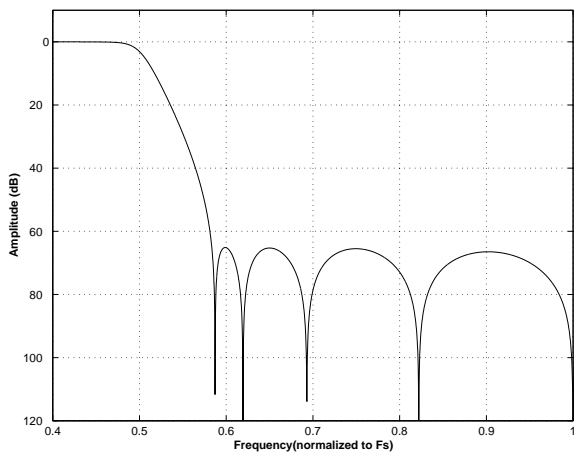
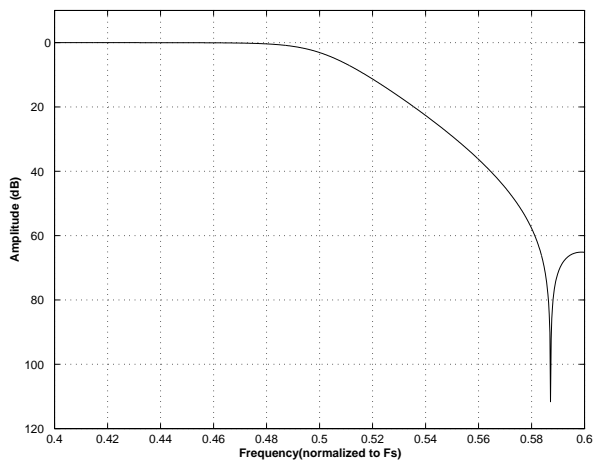
**Figure 32. S/PDIF MUX Input Circuit**

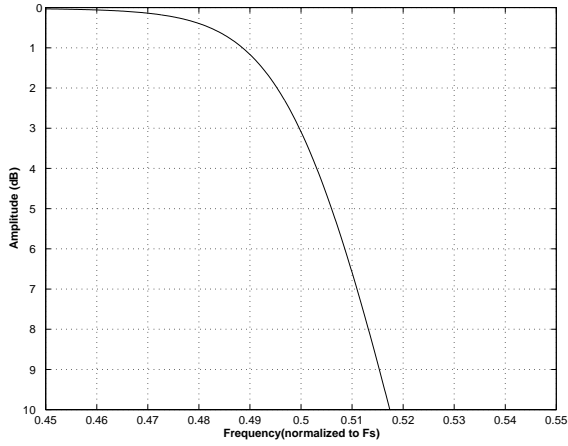
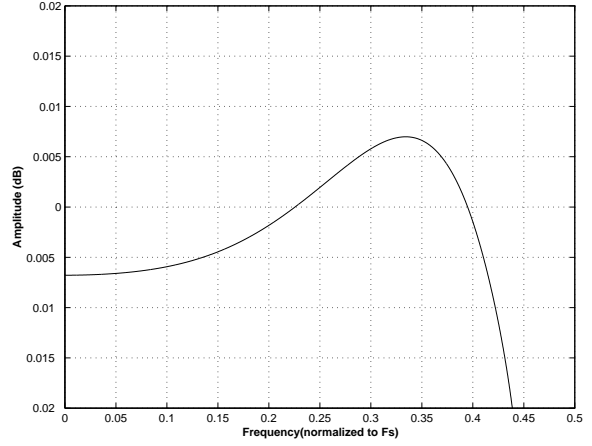
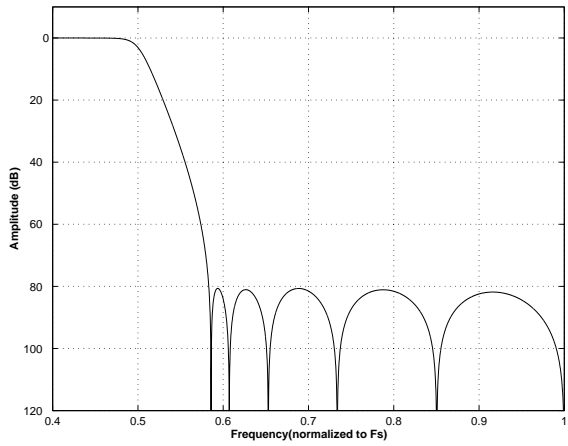
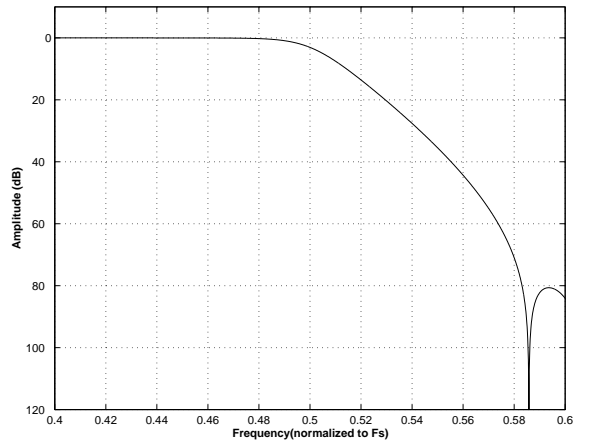
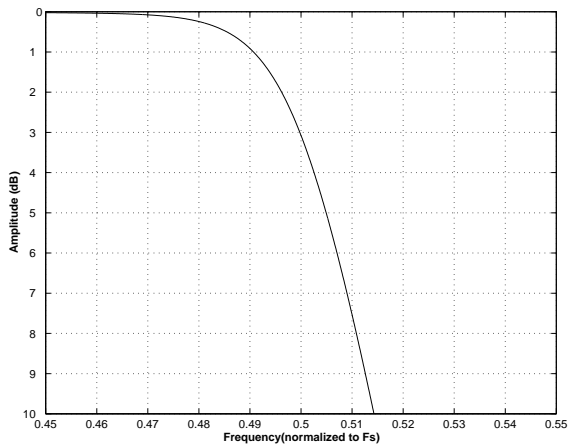
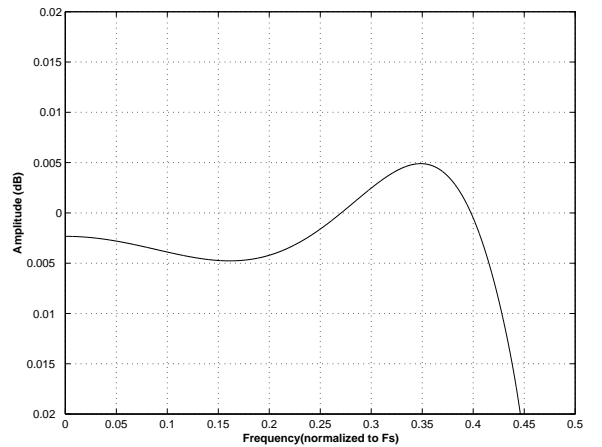


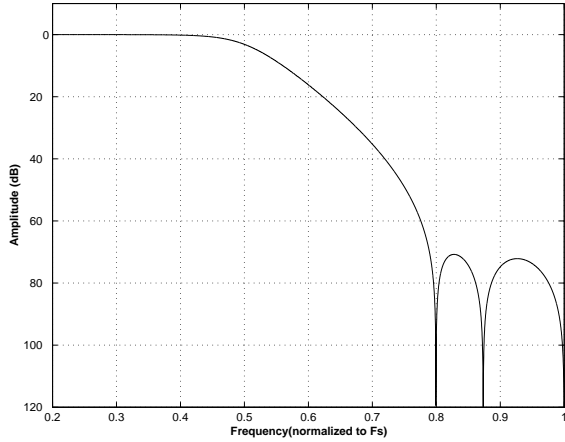
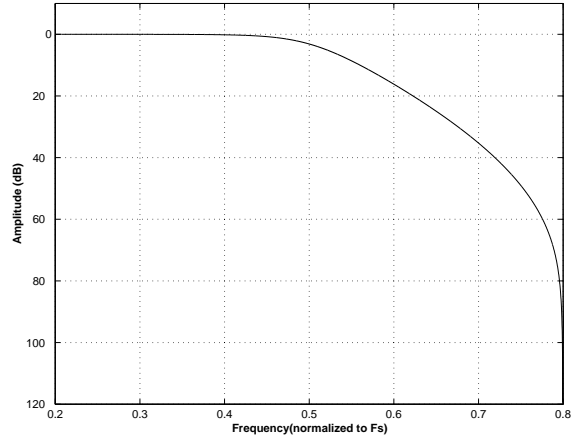
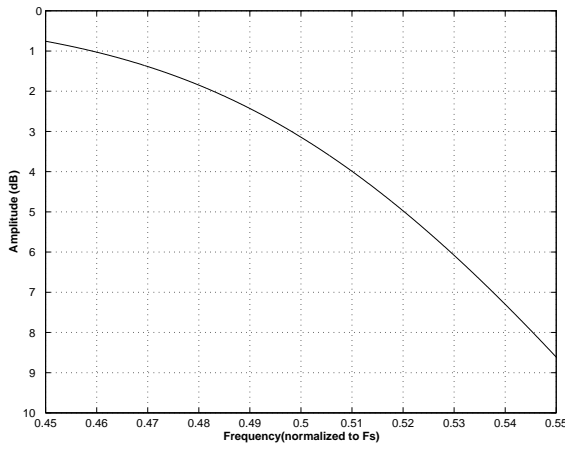
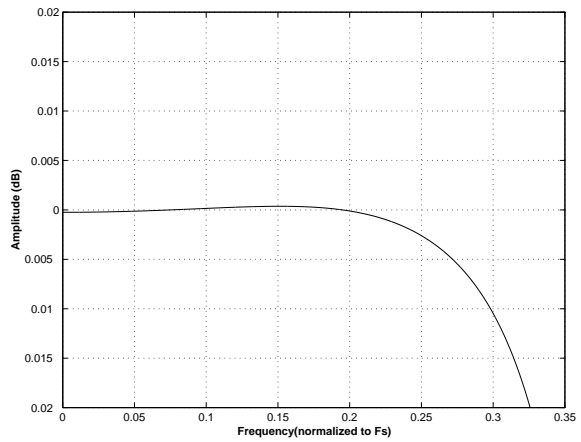
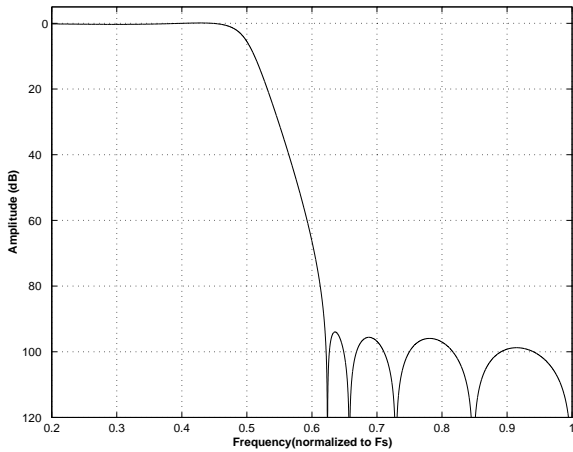
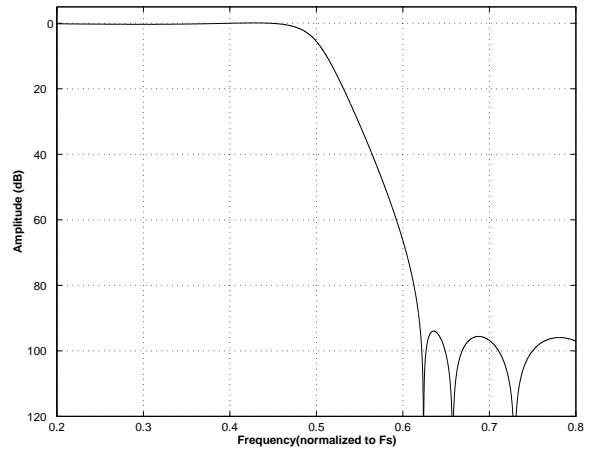
**Figure 33. TTL/CMOS Input Circuit**

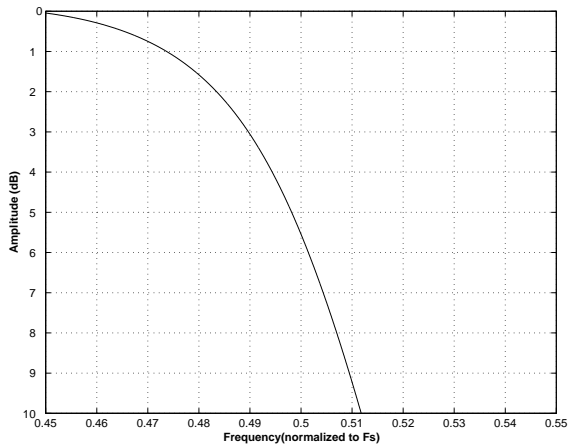
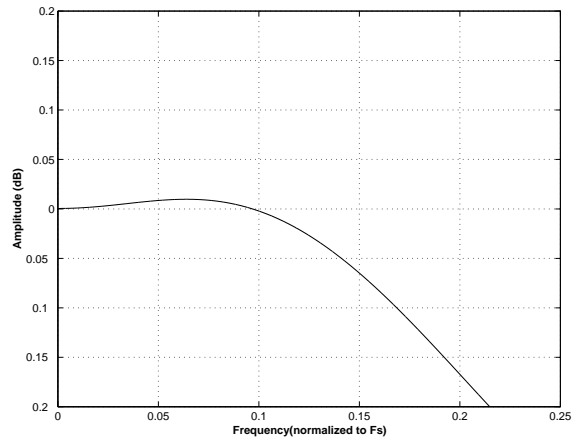
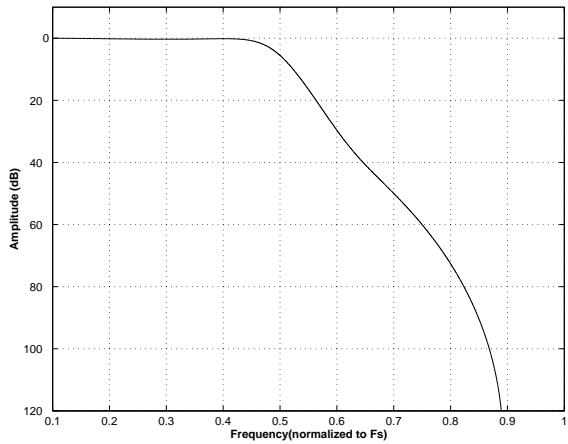
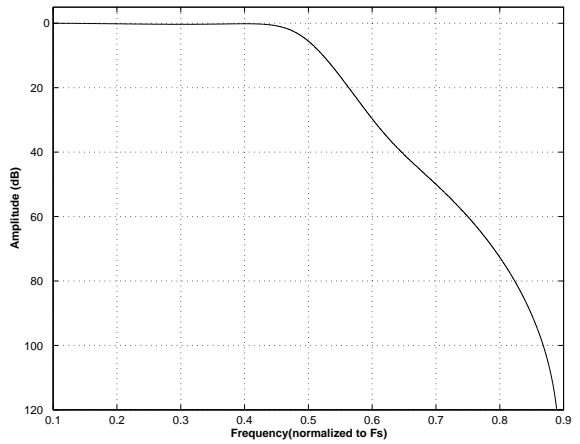
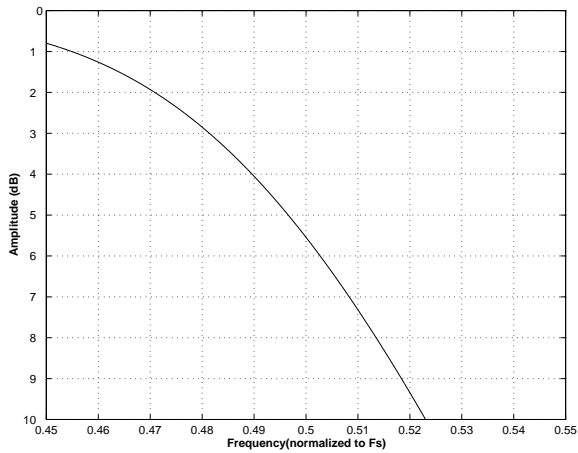
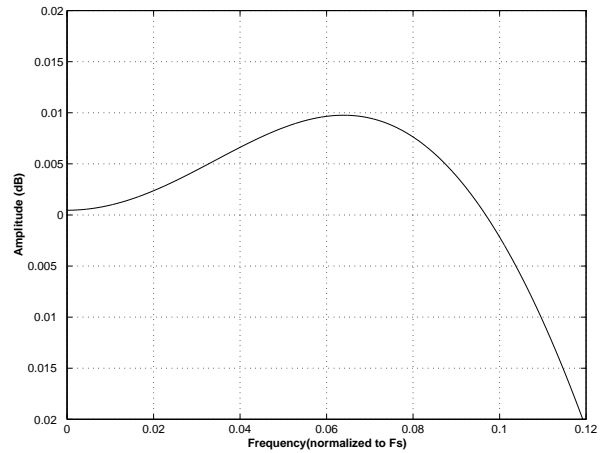
**12.APPENDIX E: ADC FILTER PLOTS**

**Figure 34. Single-Speed Mode Stopband Rejection**

**Figure 35. Single-Speed Mode Transition Band**

**Figure 36. Single-Speed Mode Transition Band (Detail)**

**Figure 37. Single-Speed Mode Passband Ripple**

**Figure 38. Double-Speed Mode Stopband Rejection**

**Figure 39. Double-Speed Mode Transition Band**


**Figure 40. Double-Speed Mode Transition Band (Detail)**

**Figure 41. Double-Speed Mode Passband Ripple**

**Figure 42. Quad-Speed Mode Stopband Rejection**

**Figure 43. Quad-Speed Mode Transition Band**

**Figure 44. Quad-Speed Mode Transition Band (Detail)**

**Figure 45. Quad-Speed Mode Passband Ripple**

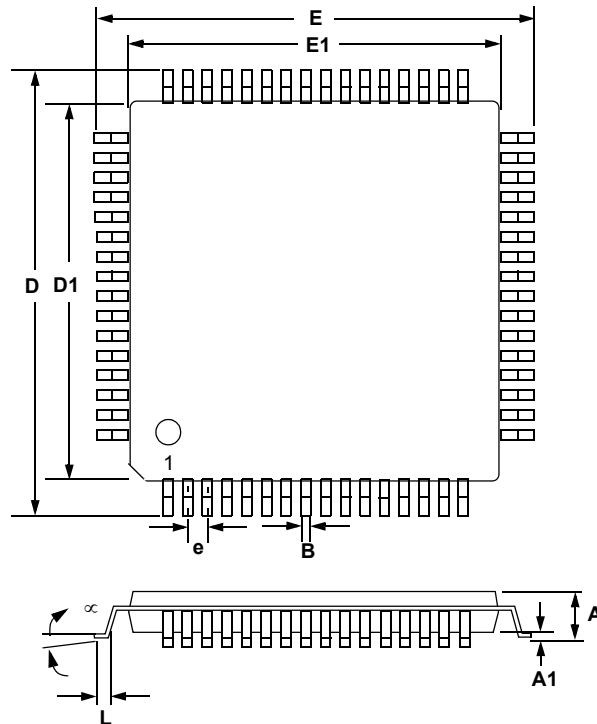
**13.APPENDIX F: DAC FILTER PLOTS**

**Figure 46. Single-Speed (fast) Stopband Rejection**

**Figure 47. Single-Speed (fast) Transition Band**

**Figure 48. Single-Speed (fast) Transition Band (detail)**

**Figure 49. Single-Speed (fast) Passband Ripple**

**Figure 50. Single-Speed (slow) Stopband Rejection**

**Figure 51. Single-Speed (slow) Transition Band**


**Figure 52. Single-Speed (slow) Transition Band (detail)**

**Figure 53. Single-Speed (slow) Passband Ripple**

**Figure 54. Double-Speed (fast) Stopband Rejection**

**Figure 55. Double-Speed (fast) Transition Band**

**Figure 56. Double-Speed (fast) Transition Band (detail)**

**Figure 57. Double-Speed (fast) Passband Ripple**


**Figure 58. Double-Speed (slow) Stopband Rejection**

**Figure 59. Double-Speed (slow) Transition Band**

**Figure 60. Double-Speed (slow) Transition Band (detail)**

**Figure 61. Double-Speed (slow) Passband Ripple**

**Figure 62. Quad-Speed (fast) Stopband Rejection**

**Figure 63. Quad-Speed (fast) Transition Band**


**Figure 64. Quad-Speed (fast) Transition Band (detail)**

**Figure 65. Quad-Speed (fast) Passband Ripple**

**Figure 66. Quad-Speed (slow) Stopband Rejection**

**Figure 67. Quad-Speed (slow) Transition Band**

**Figure 68. Quad-Speed (slow) Transition Band (detail)**

**Figure 69. Quad-Speed (slow) Passband Ripple**



**14.PACKAGE DIMENSIONS**
**64L LQFP PACKAGE DRAWING**


DIM	INCHES			MILLIMETERS		
	MIN	NOM	MAX	MIN	NOM	MAX
A	---	0.55	0.063	---	1.40	1.60
A1	0.002	0.004	0.006	0.05	0.10	0.15
B	0.007	0.008	0.011	0.17	0.20	0.27
D	0.461	0.472 BSC	0.484	11.70	12.0 BSC	12.30
D1	0.390	0.393 BSC	0.398	9.90	10.0 BSC	10.10
E	0.461	0.472 BSC	0.484	11.70	12.0 BSC	12.30
E1	0.390	0.393 BSC	0.398	9.90	10.0 BSC	10.10
e*	0.016	0.020 BSC	0.024	0.40	0.50 BSC	0.60
L	0.018	0.024	0.030	0.45	0.60	0.75
∞	0.000°	4°	7.000°	0.00°	4°	7.00°

\* Nominal pin pitch is 0.50 mm

Controlling dimension is mm.

JEDEC Designation: MS026

**THERMAL CHARACTERISTICS**

Parameter	Symbol	Min	Typ	Max	Units
Allowable Junction Temperature		-	-	+135	°C
Junction to Ambient Thermal Impedance	$\theta_{JA}$	-	48	-	°C/Watt

**15. ORDERING INFORMATION**

Product	Description	Package	Pb-Free	Grade	Temp Range	Container	Order #
CS42526	114 dB, 192 kHz 6-Ch Codec with S/PDIF Receiver	64-pin LQFP	Yes	Commercial	-10° to +70° C	Tray	CS42526-CQZ
						Tape & Reel	CS42526-CQZR
CDB42528	CS42526 Evaluation Board		No	-	-	-	CDB42528

**16. REFERENCES**

- 1) Cirrus Logic, Audio Quality Measurement Specification, Version 1.0, 1997. <http://www.cirrus.com/products/papers/meas/meas.html>
- 2) Cirrus Logic, AN18: Layout and Design Rules for Data Converters and Other Mixed Signal Devices, Version 6.0, February 1998.
- 3) Cirrus Logic, AN22: Overview of Digital Audio Interface Data Structures, Version 2.0, February 1998.; A useful tutorial on digital audio specifications.
- 4) Cirrus Logic, AN134: AES and S/PDIF Recommended Transformers, Version 2, April 1999.
- 5) Cirrus Logic, An Understanding and Implementation of the SCMS Serial Copy Management System for Digital Audio Transmission, by Clifton Sanchez.; an excellent tutorial on SCMS. It is available from the AES as preprint 3518.
- 6) Cirrus Logic, Techniques to Measure and Maximize the Performance of a 120 dB, 96 kHz A/D Converter Integrated Circuit, by Steven Harris, Steven Green and Ka Leung. Presented at the 103rd Convention of the Audio Engineering Society, September 1997.
- 7) Cirrus Logic, A Stereo 16-bit Delta-Sigma A/D Converter for Digital Audio, by D.R. Welland, B.P. Del Signore, E.J. Swanson, T. Tanaka, K. Hamashita, S. Hara, K. Takasuka. Paper presented at the 85th Convention of the Audio Engineering Society, November 1988.
- 8) Cirrus Logic, The Effects of Sampling Clock Jitter on Nyquist Sampling Analog-to-Digital Converters, and on Oversampling Delta Sigma ADC's, by Steven Harris. Paper presented at the 87th Convention of the Audio Engineering Society, October 1989.
- 9) Cirrus Logic, An 18-Bit Dual-Channel Oversampling Delta-Sigma A/D Converter, with 19-Bit Mono Application Example, by Clif Sanchez. Paper presented at the 87th Convention of the Audio Engineering Society, October 1989.
- 10) Cirrus Logic, How to Achieve Optimum Performance from Delta-Sigma A/D and D/A Converters, by Steven Harris. Presented at the 93rd Convention of the Audio Engineering Society, October 1992.
- 11) Cirrus Logic, A Fifth-Order Delta-Sigma Modulator with 110 dB Audio Dynamic Range, by I. Fujimori, K. Hamashita and E.J. Swanson. Paper presented at the 93rd Convention of the Audio Engineering Society, October 1992.
- 12) International Electrotechnical Commission, IEC60958, <http://www.ansi.org>
- 13) Philips Semiconductor, The I2C-Bus Specification: Version 2.1, January 2000. <http://www.semiconductors.philips.com>

## 17. REVISION HISTORY

Release	Date	Changes
F1	October 2005	Final Release <ul style="list-style-type: none"> <li>– Added ordering information table on <a href="#">page 90</a>.</li> <li>– Updated registers <a href="#">6.6.6</a> and <a href="#">6.6.7</a> on <a href="#">page 51</a>.</li> <li>– Updated “Slave Mode” section on <a href="#">page 25</a>.</li> <li>– Updated specification of <math>t_{dpd}</math>, and <math>t_{rpd}</math> in the Switching Characteristics table on <a href="#">page 11</a>.</li> <li>– Updated the “External Filter Components” section beginning on <a href="#">page 77</a>.</li> <li>– Updated LOCKM[1:0] bits and description on <a href="#">page 65</a>.</li> <li>– Updated RCVR_CLK[2:0] bit description on <a href="#">page 55</a>.</li> </ul>
F2	March 2014	<ul style="list-style-type: none"> <li>– Removed references to automotive-class products.</li> <li>– Changed <a href="#">Note 7</a> in “Analog Output Characteristics” on <a href="#">page 9</a> to “One LSB of triangular PDF dither is added to data.”</li> <li>– Added 100 <math>\mu</math>A spec for VOH and VOL in “Digital Interface Characteristics” on <a href="#">page 15</a>.</li> <li>– Updated legal statement on the last page.</li> </ul>

### Contacting Cirrus Logic Support

For all product questions and inquiries contact a Cirrus Logic Sales Representative.

To find the one nearest to you go to [www.cirrus.com/corporate/contacts/sales.cfm](http://www.cirrus.com/corporate/contacts/sales.cfm)

#### IMPORTANT NOTICE

Cirrus Logic, Inc. and its subsidiaries (“Cirrus”) believe that the information contained in this document is accurate and reliable. However, the information is subject to change without notice and is provided “AS IS” without warranty of any kind (express or implied). Customers are advised to obtain the latest version of relevant information to verify, before placing orders, that information being relied on is current and complete. All products are sold subject to the terms and conditions of sale supplied at the time of order acknowledgment, including those pertaining to warranty, indemnification, and limitation of liability. No responsibility is assumed by Cirrus for the use of this information, including use of this information as the basis for manufacture or sale of any items, or for infringement of patents or other rights of third parties. This document is the property of Cirrus and by furnishing this information, Cirrus grants no license, express or implied under any patents, mask work rights, copyrights, trademarks, trade secrets or other intellectual property rights. Cirrus owns the copyrights associated with the information contained herein and gives consent for copies to be made of the information only for use within your organization with respect to Cirrus integrated circuits or other products of Cirrus. This consent does not extend to other copying such as copying for general distribution, advertising or promotional purposes, or for creating any work for resale.

CERTAIN APPLICATIONS USING SEMICONDUCTOR PRODUCTS MAY INVOLVE POTENTIAL RISKS OF DEATH, PERSONAL INJURY, OR SEVERE PROPERTY OR ENVIRONMENTAL DAMAGE (“CRITICAL APPLICATIONS”). CIRRUS PRODUCTS ARE NOT DESIGNED, AUTHORIZED OR WARRANTED FOR USE IN AIRCRAFT SYSTEMS, MILITARY APPLICATIONS, PRODUCTS SURGICALLY IMPLANTED INTO THE BODY, AUTOMOTIVE SAFETY OR SECURITY DEVICES, LIFE SUPPORT PRODUCTS OR OTHER CRITICAL APPLICATIONS. INCLUSION OF CIRRUS PRODUCTS IN SUCH APPLICATIONS IS UNDERSTOOD TO BE FULLY AT THE CUSTOMER’S RISK AND CIRRUS DISCLAIMS AND MAKES NO WARRANTY, EXPRESS, STATUTORY OR IMPLIED, INCLUDING THE IMPLIED WARRANTIES OF MERCHANTABILITY AND FITNESS FOR PARTICULAR PURPOSE, WITH REGARD TO ANY CIRRUS PRODUCT THAT IS USED IN SUCH A MANNER. IF THE CUSTOMER OR CUSTOMER’S CUSTOMER USES OR PERMITS THE USE OF CIRRUS PRODUCTS IN CRITICAL APPLICATIONS, CUSTOMER AGREES, BY SUCH USE, TO FULLY INDEMNIFY CIRRUS, ITS OFFICERS, DIRECTORS, EMPLOYEES, DISTRIBUTORS AND OTHER AGENTS FROM ANY AND ALL LIABILITY, INCLUDING ATTORNEYS’ FEES AND COSTS, THAT MAY RESULT FROM OR ARISE IN CONNECTION WITH THESE USES.

Cirrus Logic, Cirrus, and the Cirrus Logic logo designs are trademarks of Cirrus Logic, Inc. All other brand and product names in this document may be trademarks or service marks of their respective owners.

AC-3 is a registered trademark of Dolby Laboratories, Inc.

DTS is a registered trademark of Digital Theater Systems, Inc.

HDCD is a registered trademark of Microsoft Corporation. HDCD technology cannot be used or distributed without a license from Microsoft Licensing, Inc.

SPI is a trademark of Motorola, Inc.

PC is a trademark of Philips Semiconductor.

## X-ON Electronics

Largest Supplier of Electrical and Electronic Components

*Click to view similar products for [Interface - CODECs](#) category:*

*Click to view products by [Cirrus](#) manufacturer:*

Other Similar products are found below :

[CS4205-KQZ](#) [ZL38015QCG1](#) [MAX98090AEWJ+T](#) [WM9713CLGEFLV](#) [LE58QL061BVC](#) [MAX9867ETJ+G3U](#) [ADAU1777BCBZRL](#)  
[WM8944BECS/R](#) [TDA7293V-E](#) [WM8998ECS/R](#) [WM8778SEDS/V](#) [CS42L73-CRZR](#) [WM8750CJLGEFL](#) [STA529Q](#) [SSM2603CPZ-REEL](#)  
[TLV320AIC14IDBT](#) [TLV320AIC23BIPWRQ1](#) [TLV320AIC23IPW](#) [TVP5151PBSR](#) [MAX98090BETL+](#) [MAX98089ETN+](#)  
[MAX98089ETNT](#) [TLV320AIC34IZASR](#) [TLV320AIC3262IYZFR](#) [SA612AD/01.112](#) [ADAU1372BCPZ-RL](#) [MAX9880AETM](#)  
[WM8962ECSN/R](#) [TLV320DAC3203IRGER](#) [WM8904CGEFL/RV](#) [6PAIC3106IRGZRQ1](#) [CS42436-DMZ](#) [TSCS25A3X1NDGXZAX](#)  
[BU94502CMUV-E2](#) [TDA8932BT/N2.112](#) [TDA8954J/N1.112](#) [ICS501MLFT](#) [ICS512MLF](#) [92HD73C1X5PRGXC1X](#) [SSM2167-1RMZ](#)  
[AD1836AASZ](#) [AD1836ACSZ](#) [AD1928YSTZ](#) [AD1937WBSTZ](#) [AD1939WBSTZ](#) [AD73311ARSZ](#) [AD73311ARZ](#) [AD73311LARUZ](#)  
[AD73322LARUZ](#) [AD74111YRUZ](#)