

## Low-Cost, Power-On Reset and Watchdog Controllers

### General Description

The MAX698/MAX699 monitor the +5V supply in micro-processor ( $\mu$ P) and digital systems. They supply a  $\overline{\text{RESET}}$  pulse of at least 140ms duration on power-up, power-down, and during low-voltage brownout conditions. Circuit reliability is increased at reduced cost by eliminating all external components and adjustments.

The MAX699 includes all features of the MAX698, but also provides a watchdog input to monitor microprocessor activity. The  $\overline{\text{RESET}}$  output goes low if the watchdog input (WDI) is not toggled within 1 second. The watchdog feature can be disabled by leaving WDI open.

Both parts are supplied in 8-lead PDIP and 16-lead 0.3in wide small outline (SO) packages and are specified from 0°C to +70°C for C grade devices and -40°C to +85°C for E devices. The SO versions, with more pins than the 8-lead PDIP, have additional outputs not available in DIP packages. These are  $\overline{\text{RESET}}$  (without inversion) and watchdog output (WDO).

### Applications

- Computers
- Controllers
- Intelligent Instruments
- Automotive Systems
- Critical  $\mu$ P Power Monitoring

### Typical Operating Circuit

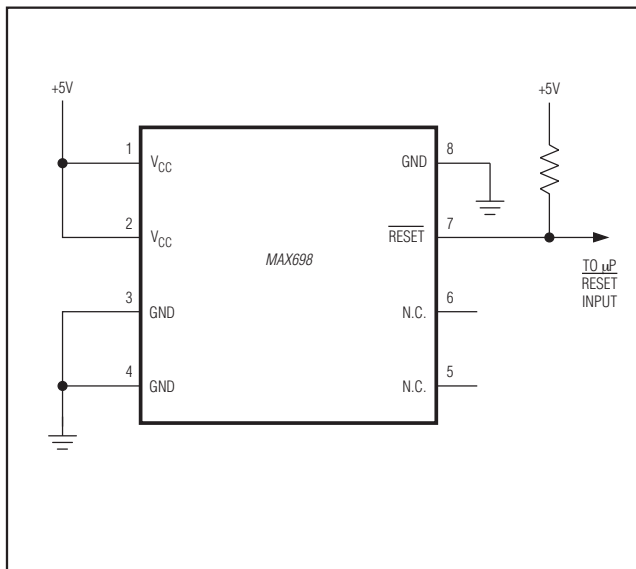

### Features

- ◆ Precision Voltage Monitor
- ◆ Power-OK/Reset Time Delay
- ◆ Watchdog Timer
- ◆ Minimum Component Count

### Ordering Information

PART*	TEMP RANGE	PIN-PACKAGE
MAX698CPA	0°C to +70°C	8 PDIP
MAX698CWE	0°C to +70°C	16 Wide SO
MAX698EPA	-40°C to +85°C	8 PDIP
MAX698EWE	-40°C to +85°C	16 Wide SO
MAX699CPA	0°C to +70°C	8 PDIP
MAX699CWE	0°C to +70°C	16 Wide SO
MAX699EPA	-40°C to +85°C	8 PDIP
MAX699EWE	-40°C to +85°C	16 Wide SO

\*Devices are available in both leaded and lead(Pb)-free packaging. Specify lead free by adding the + symbol at the end of the part number when ordering.

### Pin Configuration

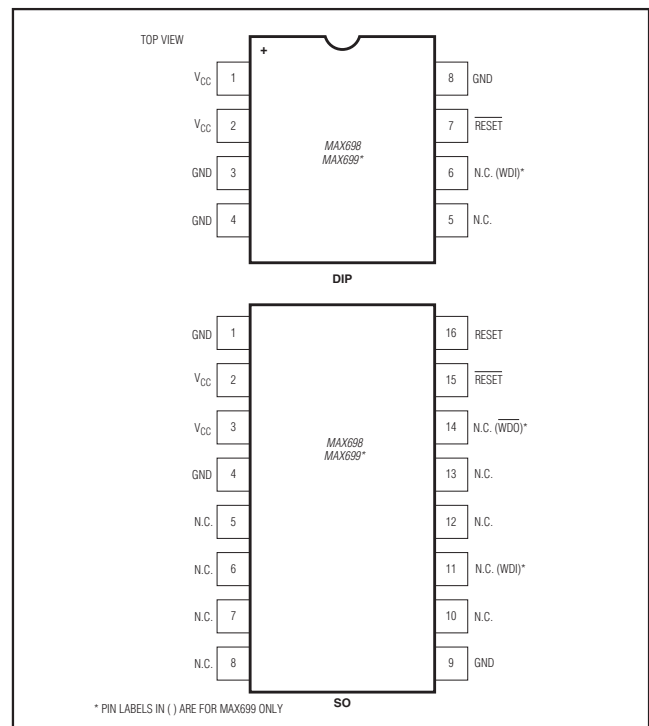

# MAX698/MAX699

## Low-Cost, Power-On Reset and Watchdog Controllers

### ABSOLUTE MAXIMUM RATINGS

V<sub>CC</sub> .....-0.3V to +6.0V  
 Input Voltage (with respect to GND)  
 WDI, WDO, RESET,  $\overline{\text{RESET}}$  .....-0.3V to V<sub>CC</sub>  
 Operating Temperature Range  
   C Suffix .....0°C to +70°C  
   E Suffix .....-40°C to +85°C  
 Rate of Rise, V<sub>CC</sub> .....100V/μs

Power Dissipation (T<sub>A</sub> = +70°C)  
   8-Pin PDIP (derated 5mW/°C above +70°C) .....400mW  
   16-Pin SO (derated 7mW/°C above +70°C) .....600mW  
 Storage Temperature Range .....-65°C to +150°C  
 Lead Temperature (soldering, 10s) .....+300°C

*Stresses beyond those listed under "Absolute Maximum Ratings" may cause permanent damage to the device. These are stress ratings only, and functional operation of the device at these or any other conditions beyond those indicated in the operational sections of the specifications is not implied. Exposure to absolute maximum rating conditions for extended periods may affect device reliability.*

### ELECTRICAL CHARACTERISTICS

(V<sub>CC</sub> = +5V, T<sub>A</sub> = +25°C, unless otherwise noted.)

PARAMETER	CONDITIONS		MIN	TYP	MAX	UNITS
Operating Voltage Range	T <sub>A</sub> = full		3.0		5.5	V
Supply Current					5	mA
Power-Up Reset Deassertion	T <sub>A</sub> = full		4.50	4.65	4.75	V
Power-Up Reset Assertion	T <sub>A</sub> = full		4.4			V
Hysteresis				40		mV
Reset Output Pulse Width			140		500	ms
$\overline{\text{RESET}}$ OUTPUT (Open Drain)	Output low	I <sub>SINK</sub> = 1.6mA, V <sub>CC</sub> = 4.4V			0.4	V
	Output high	I <sub>SOURCE</sub> = 1μA, V <sub>CC</sub> = 5V	3.5			
RESET OUTPUT (SO Package Only)	Output low	I <sub>SINK</sub> = 1.6mA, V <sub>CC</sub> = 5V			0.4	V
	Output high	I <sub>SOURCE</sub> = 1μA, V <sub>CC</sub> = 4.4V	3.5			
WDO Output (MAX699 SO Package Only)	Output low	I <sub>SINK</sub> = 1.6mA, V <sub>CC</sub> = 5V			0.4	V
	Output high	I <sub>SOURCE</sub> = 1μA, V <sub>CC</sub> = 4.4V	3.5			
MAX699 Watchdog Timeout Period			1.00	1.6	2.25	s
MAX699 Minimum WDI Input Pulse Width			200			ns
MAX699 WDI Input Threshold	V <sub>CC</sub> = +5V	Logic-low			0.8	V
		Logic-high	3.8			
MAX699 WDI Input Current	WDI = V <sub>CC</sub>			20	50	μA
	WDI = 0V		-50	-15		

# MAX698/MAX699

## Low-Cost, Power-On Reset and Watchdog Controllers

### Pin Description

PIN		NAME	FUNCTION
SO	PDIP		
1, 4, 9	3, 4, 8	GND	Chip Power Ground
2, 3	1, 2	V <sub>CC</sub>	+5V Sense Input and MAX698/MAX699 Chip Power
5–8, 10–14	5, 6	N.C.	No Connection
11	6	WDI (MAX699 Only)	(MAX699 Only.) A three-level input. If WDI remains high or low for more than the watchdog timeout period, $\overline{\text{RESET}}$ pulses low ( $\overline{\text{WDO}}$ also goes low on the MAX699 SO package). If WDI is unconnected, the watchdog circuit is disabled.
14	—	$\overline{\text{WDO}}$ (MAX699 Only)	(MAX699 Only.) Goes low when WDI remains high or low for more than the watchdog timeout period. $\overline{\text{WDO}}$ is set high at the next WDI transition. If WDI is unconnected or at midsupply, $\overline{\text{WDO}}$ remains high. $\overline{\text{WDO}}$ also remains high when V <sub>CC</sub> falls below 4.4V.
15	7	$\overline{\text{RESET}}$	Goes low when V <sub>CC</sub> falls below internally set threshold (see the <i>Electrical Characteristics</i> table).
16	—	RESET	Goes high when V <sub>CC</sub> falls below internally set threshold.

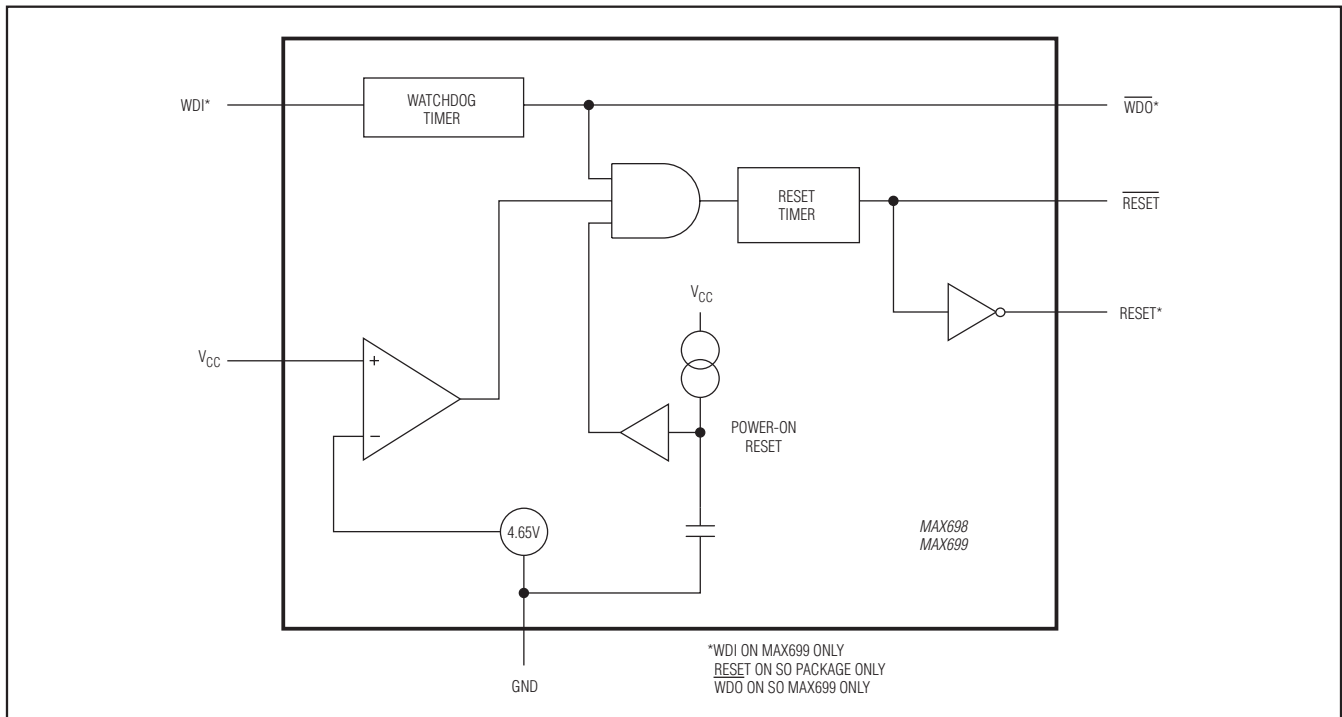

Figure 1. Block Diagram

# MAX698/MAX699

## Low-Cost, Power-On Reset and Watchdog Controllers

### Package Information

For the latest package outline information and land patterns (footprints), go to [www.maximintegrated.com/packages](http://www.maximintegrated.com/packages). Note that a "+", "#", or "-" in the package code indicates RoHS status only. Package drawings may show a different suffix character, but the drawing pertains to the package regardless of RoHS status.

PACKAGE TYPE	PACKAGE CODE	OUTLINE NO.	LAND PATTERN NO.
8 PDIP	P8-2	<a href="#">21-0043</a>	—
16 Wide SO	W16-1	<a href="#">21-0042</a>	<a href="#">90-0107</a>

### Chip Topography

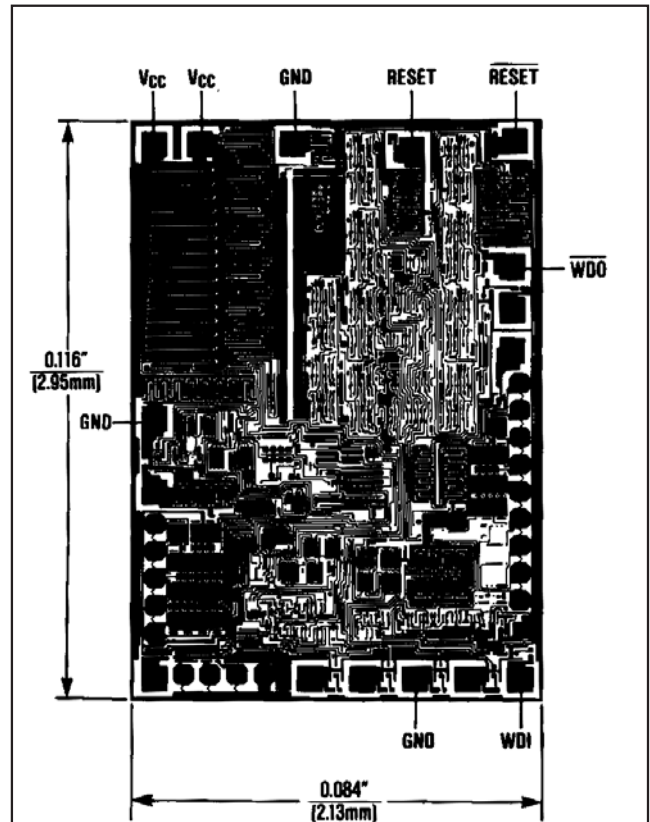

# MAX698/MAX699

## Low-Cost, Power-On Reset and Watchdog Controllers

### Revision History

REVISION NUMBER	REVISION DATE	DESCRIPTION	PAGES CHANGED
4	5/13	Corrected WDI SO pin number in <i>Pin Description</i>	3



Maxim Integrated cannot assume responsibility for use of any circuitry other than circuitry entirely embodied in a Maxim Integrated product. No circuit patent licenses are implied. Maxim Integrated reserves the right to change the circuitry and specifications without notice at any time. The parametric values (min and max limits) shown in the Electrical Characteristics table are guaranteed. Other parametric values quoted in this data sheet are provided for guidance.

**Maxim Integrated 160 Rio Robles, San Jose, CA 95134 USA 1-408-601-1000**

5

## X-ON Electronics

Largest Supplier of Electrical and Electronic Components

*Click to view similar products for [Supervisory Circuits](#) category:*

*Click to view products by [Maxim](#) manufacturer:*

Other Similar products are found below :

[NCP304LSQ38T1G](#) [NCP304LSQ42T1G](#) [NCP304LSQ43T1G](#) [NCP305LSQ11T1G](#) [NCP305LSQ16T1G](#) [NCP305LSQ17T1G](#)

[NCP305LSQ18T1G](#) [NCP305LSQ24T1G](#) [NCP305LSQ25T1G](#) [NCP305LSQ29T1G](#) [NCP305LSQ31T1G](#) [NCP305LSQ32T1G](#)

[NCP308MT250TBG](#) [NCP308SN300T1G](#) [NCP391FCALT2G](#) [NCV303LSN42T1G](#) [NCV308SN330T1G](#) [CAT1161LI-25-G](#) [CAT853STBI-T3](#)

[CAT1026LI-30-G](#) [CAT1320LI-25-G](#) [CAT872-30ULGT3](#) [NCP304HSQ18T1G](#) [NCP304HSQ29T1G](#) [NCP304LSQ27T1G](#) [NCP304LSQ29T1G](#)

[NCP304LSQ45T1G](#) [NCP305LSQ26T1G](#) [NCP305LSQ35T1G](#) [NCP305LSQ37T1G](#) [NCP308MT300TBG](#) [NCV300LSN36T1G](#)

[NCV302LSN30T1G](#) [NCV303LSN16T1G](#) [NCV303LSN22T1G](#) [NCV303LSN27T1G](#) [NCV33161DMR2G](#) [TC54VN2402EMB713](#)

[MCP1316T-44NE/OT](#) [MCP1316MT-45GE/OT](#) [MCP1316MT-23LI/OT](#) [MCP1316T-26LE/OT](#) [MAX8997EWW+](#) [MAX821RUS+T](#)

[MAX6725AKASYD3-LF-T](#) [MAX6445UK31L+T](#) [MAX809SEUR](#) [MAX6701LKA+](#) [MAX16126TCA+T](#) [MAX16046ATN+](#)