

FEATURES

- Designed Specifically to Drive Large and Small Q_G PFETs
- Very Low Loss Replacement for Power Supply OR'ing Diodes
- Wide Operating Voltage Range: 3.6V to 36V
- -40°C to 125°C Operating Temperature Range
- Reverse Battery Protection
- Automatic Switching Between DC Sources
- Low Quiescent Current: $35\mu\text{A}$ per Channel
- Load Current Sharing
- MOSFET Gate Protection Clamp
- Precision Input Control Comparators for Setting Switchover Threshold Points
- Open-Drain Feedback Points for Customer Specified Hysteresis Control
- Minimal External Components
- Space Saving 10-Lead MSOP Package

APPLICATIONS

- High Current PowerPath Switch
- Industrial and Automotive Applications
- Uninterruptible Power Supplies
- Logic Controlled Power Switch
- Battery Backup System
- Emergency Systems with Battery Backups

DESCRIPTION

The LTC[®]4416/LTC4416-1 control two sets of external P-channel MOSFETs to create two near ideal diode functions for power switchover circuits. This permits highly efficient OR'ing of multiple power sources for extended battery life and low self heating. When conducting, the voltage drop across the MOSFET is typically 25mV. For applications with a wall adapter or other auxiliary power source, the load is automatically disconnected from the battery when the auxiliary source is connected.

The LTC4416 integrates two interconnected PowerPath™ controllers with soft switchover control. The “soft-off” switchover permits the users to transfer between two dissimilar voltages without excessive voltage undershoot (or V_{DROOP}) in the output supply. The LTC4416/LTC4416-1 also contain a “fast-on” feature that dramatically increases gate drive current when the forward input voltage exceeds 25mV. The LTC4416 “fast off” feature is engaged when the sense voltage exceeds the input voltage by 25mV. The LTC4416-1 enables the fast off under the same conditions and when the other external P-channel device is selected using the enable pins.

The wide operating supply range supports operation from one to eight Li-Ion cells in series. The low quiescent current ($35\mu\text{A}$ per channel) is independent of the load current. The gate driver includes an internal voltage clamp for MOSFET protection.

The LTC4416/LTC4416-1 are available in low profile 10-lead MSOP packages.

LT, LT, LTC and LTM are registered trademarks of Linear Technology Corporation.
 PowerPath is a trademark of Linear Technology Corporation.
 All other trademarks are the property of their respective owners.

TYPICAL APPLICATION

Automatic PowerPath Switchover



LTC4416 vs Schottky Diode Forward Voltage Drop

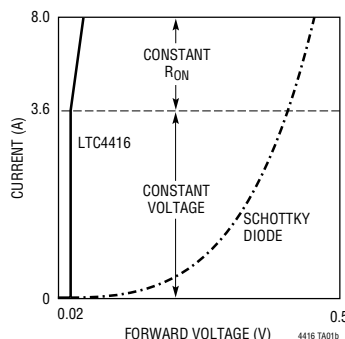

Under and Overvoltage Shutdown Operation

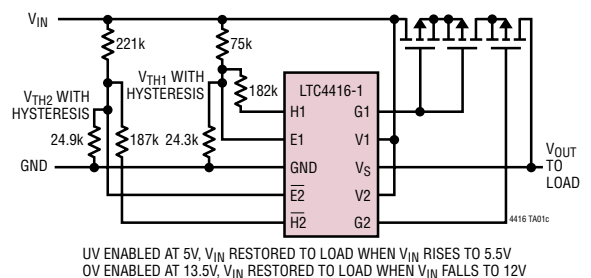

UV ENABLED AT 5V, V_{IN} RESTORED TO LOAD WHEN V_{IN} RISES TO 5.5V
 OV ENABLED AT 13.5V, V_{IN} RESTORED TO LOAD WHEN V_{IN} FALLS TO 12V

4416fa

LTC4416/LTC4416-1

ABSOLUTE MAXIMUM RATINGS

(Note 1)

Supply Voltage (V1, V2).....	-14V to 40V
Voltage from V1 or V2 to V _S	-40V to 40V
Input Voltage	
E1, E2	-0.3V to 40V
V _S	-14V to 40V
Output Voltage	
G1	-0.3V to the Higher of V1 + 0.3V or V _S + 0.3V
G2	-0.3V to the Higher of V2 + 0.3V or V _S + 0.3V
H1, H2	-0.3V to 7V
Operating Ambient Temperature Range (Note 2)	
LTC4416E	-40°C to 85°C
LTC4416I	-40°C to 125°C
Operating Junction	
Temperature Range.....	-40°C to 125°C
Storage Temperature Range.....	-65°C to 150°C
Lead Temperature (Soldering, 10 sec)	300°C

PACKAGE/ORDER INFORMATION

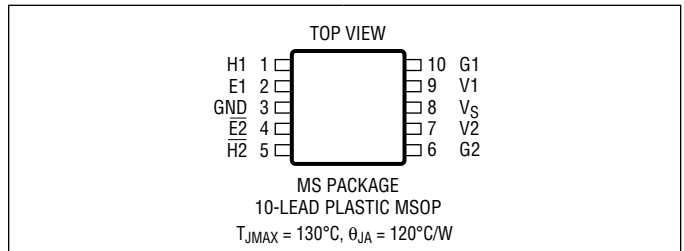

ORDER PART NUMBER	MS PART MARKING*
LTC4416EMS	LTCFC
LTC4416IMS	LTCFC
LTC4416EMS-1	LTCPS
LTC4416IMS-1	LTCPS

Order Options Tape and Reel: Add #TR
 Lead Free: Add #PBF Lead Free Tape and Reel: Add #TRPBF
 Lead Free Part Marking: <http://www.linear.com/leadfree/>

Consult LTC Marketing for parts specified with wider operating temperature ranges.
 *The temperature grade is identified by a label on the shipping container.

ELECTRICAL CHARACTERISTICS

The ● denotes the specifications which apply over the full operating temperature range, otherwise specifications are at T_A = 25°C. V1 = V2 = 12V, E1 = 2V, E2 = GND, GND = 0V. Current into a pin is positive and current out of a pin is negative. All voltages are referenced to GND, unless otherwise specified.

SYMBOL	PARAMETER	CONDITIONS	MIN	TYP	MAX	UNITS
V _{V1} , V _{V2} , V _{VS}	Operating Supply Range	V1, V2 and/or V _S Must be in This Range for Proper Operation	● 3.6		36	V
I _{QFL}	Quiescent Supply Current at Low Supply While in Forward Regulation	V _{V1} = 3.6V, V _{V2} = 3.6V. Measure Combined Current at V1, V2 and V _S Pins Averaged with V _{VS} = 3.560V and V _{VS} = 3.6V (Note 3)	●		70	μA
I _{QFH}	Quiescent Supply Current at High Supply While in Forward Regulation	V _{V1} = 36V, V _{V2} = 36V. Measure Combined Current at V1, V2 and V _S Pins Averaged with V _{VS} = 35.960V and V _{VS} = 36V (Note 3)	●		130	μA
I _{QRL}	Quiescent Supply Current at Low Supply While in Reverse Turn-Off	V _{V1} = 3.6V, V _{V2} = 3.6V. Measure Combined Current at V1, V2 and V _S Pins with V _{VS} = 3.7V	●		70	μA
I _{QRH}	Quiescent Supply Current at High Supply While in Reverse Turn-Off	V _{V1} = 35.9V, V _{V2} = 35.9V. Measure Combined Current at V1, V2 and V _S Pins with V _{VS} = 36V	●		130	μA
I _{QCL}	Quiescent Supply Current at Low Supply with E1 and E2 Active	V _{V1} = 3.6V, V _{V2} = 3.6V, V _{V1} - V _{VS} = 0.9V, V _{E1} = 0V, V _{E2} = 2V, V1 and V2 Measured Separately	●		30	μA
I _{QCH}	Quiescent Supply Current at High Supply with E1 and E2 Active	V _{V1} = 36V, V _{V2} = 36V, V _{V1} - V _{VS} = 0.9V, V _{E1} = 0V, V _{E2} = 2V, V1 and V2 Measured Separately	●		65	μA
I _{LEAK}	V1, V2 and V _S Pin Leakage Currents When Other Pin Supplies Power (Note 4)	V _{V1} = V _{V2} = 28V, V _{VS} = 0V. Measure I _{VS}	-10	-1	1	μA
		V _{V1} = V _{V2} = 14V, V _{VS} = -14V. Measure I _{VS}	-10	-1	1	μA
		V _{V1} = V _{V2} = 36V, V _{VS} = 8V. Measure I _{VS}	-10	-1	1	μA

PowerPath Controller

V _{FR}	PowerPath Switch Forward Regulation Voltage	V _{V1} , V _{V2} - V _{VS} , 3.6V ≤ V _{V1} , V _{V2} ≤ 36V, C _{G1} = C _{G2} = 3nF	●	10	40	mV
V _{RTO}	PowerPath Switch Reverse Turn-Off Threshold Voltage	V _{V1} , V _{V2} - V _{VS} , 3.6V ≤ V _{V1} , V _{V2} ≤ 36V, C _{G1} = C _{G2} = 3nF	●	-40	-10	mV
V _{FO}	PowerPath Switch Forward Fast-On Voltage Comparator Threshold	V _{V1} , V _{V2} - V _{VS} , 6V ≤ V _{V1} , V _{V2} ≤ 36V, C _{G1} = C _{G2} = 3nF, I _{G1} , I _{G2} > 500μA	●	50	125	mV

4416fa

ELECTRICAL CHARACTERISTICS The ● denotes the specifications which apply over the full operating temperature range, otherwise specifications are at $T_A = 25^\circ\text{C}$. $V_1 = V_2 = 12\text{V}$, $E_1 = 2\text{V}$, $E_2 = \text{GND}$, $\text{GND} = 0\text{V}$. Current into a pin is positive and current out of a pin is negative. All voltages are referenced to GND, unless otherwise specified.

SYMBOL	PARAMETER	CONDITIONS	MIN	TYP	MAX	UNITS	
G1, G2 Controller							
$I_{G(\text{SRC})}$	GATE Active Forward Regulation Source Current	(Note 5)	-9		-2	μA	
$I_{G(\text{SNK})}$	Sink Current	(Note 6)	15		200	μA	
$I_{G(\text{FO})}$	Sink Current During Fast-On	(Note 7)	500			μA	
$I_{G(\text{OFF})}$	Source Current During Fast-Off	(Note 12)			-500	μA	
$V_{G(\text{ON})}$	G1 and G2 Clamp Voltage	Apply $I_{G1} = I_{G2} = 2\mu\text{A}$, $V_{V1} = V_{V2} = 12\text{V}$, $V_{VS} = 11.8\text{V}$, Measure $V_{V1} - V_{G1}$ or $V_{V2} - V_{G2}$	● 7.4	8.25	9.1	V	
$V_{G(\text{OFF})}$	G1 and G2 Off Voltage	Apply $I_{G1} = I_{G2} = -30\mu\text{A}$, $V_{V1} = V_{V2} = 12\text{V}$, $V_{VS} = 12.2\text{V}$, Measure $V_{V1} - V_{G1}$ or $V_{V2} - V_{G2}$	●	0.350	0.920	V	
$t_{G(\text{ON})}$	G1 and G2 Turn-On Time	$V_{GS} < -6\text{V}$, $C_G = 17\text{nF}$ (Note 8)	●		60	μs	
$t_{G(\text{OFF})}$	G1 and G2 Turn-Off Time	$V_{GS} > -1.5\text{V}$, $C_G = 17\text{nF}$ (Note 9)	●		30	μs	
$t_{E(\text{OFF})}$	Enable Comparator Turn-Off Delay	(Note 14) LTC4416-1 Only	●		6	μs	
H1 and H2 Open-Drain Drivers							
$I_{H(\text{OFF})}$	H1 and H2 Off Current	$3.6\text{V} \leq V_{V1}$, $V_{V2} \leq 36\text{V}$ (Note 10)	●	-1	1	μA	
$V_{H(\text{ON})}$	H1 and H2 On Voltage	$3.6\text{V} \leq V_{V1}$, $V_{V2} \leq 36\text{V}$ (Note 10)	●		100	mV	
$t_{H(\text{ON})}$	H1 and H2 Turn-On Time	(Note 11)			5	μs	
$t_{H(\text{OFF})}$	H1 and H2 Turn-Off Time	(Note 11)			10	μs	
E1 and E2 Enable Input Comparators							
V_{REF}	E1 and E2 Input Threshold Voltage	$3.6\text{V} \leq V_{V1}$, $V_{V2} \leq 36\text{V}$, -40°C to 85°C $4\text{V} \leq V_{V1}$, $V_{V2} \leq 36\text{V}$, -40°C to 125°C		1.180	1.215	1.240	V
I_E	E1 and E2 Input Leakage Current	$0\text{V} \leq V_{E1}$, $V_{E2} \leq 1.5\text{V}$	●	-100	100	nA	
$I_{G(\text{ENOFF})}$	Source Current When Other Channel Enabled (Note 13) LTC4416 LTC4416-1			-9	-3	μA	
				-500		μA	

Note 1: Stresses beyond those listed under Absolute Maximum Ratings may cause permanent damage to the device. Exposure to any Absolute Maximum Rating condition for extended periods may affect device reliability and lifetime.

Note 2: The LTC4416E is guaranteed to meet performance specifications from 0°C to 85°C . Specifications over the -40°C to 85°C operating temperature range are assured by design, characterization and correlation with statistical process controls. The LTC4416I is guaranteed and tested over the -40°C to 125°C operating temperature range.

Note 3: This results in the same supply current as would be observed with an external P-channel MOSFET connected to the LTC4416 and operating in forward regulation.

Note 4: Only 3 of 9 permutations illustrated. This specification is the same when power is provided through V_S or V_2 . This specification is only valid when V_1 , V_2 and V_S are within 28V of each other.

Note 5: V_1 and V_2 are held at 12V and G1 and G2 are forced to 9V. V_S is set at 12V to measure the source current at either G1 or G2.

Note 6: V_1 and V_2 are held at 12V and G1 and G2 are forced to 9V. V_S is set at 11.96V to measure the sink current at either G1 or G2.

Note 7: V_1 and V_2 are held at 12V and G1 and G2 are forced to 9V. V_S is set at 11.875V to measure the sink current at either G1 or G2.

Note 8: V_1 and V_2 are held at 12V and V_S is stepped from 12.2V to 11.8V to trigger the event. G1 and G2 voltages are initially $V_{G(\text{OFF})}$.

Note 9: V_1 and V_2 are held at 12V and V_S is stepped from 11.8V to 12.2V to trigger the event. G1 and G2 voltages are initially $V_{G(\text{ON})}$.

Note 10: H1 and H2 are forced to 2V. E1 and E2 are forced to 1.5V to measure the off current of H1 and H2. H1 and H2 are forced with 1mA to measure the on voltage of H1 and H2.

Note 11: H1 and H2 are forced to 2V. E1 and E2 are stepped from 1.3V to 1.1V to measure $t_{S(\text{ON})}$. E1 and E2 are stepped from 1.1V to 1.3V to measure $t_{S(\text{OFF})}$.

Note 12: V_1 and V_2 are held at 12V and G1 and G2 are forced to 9V. V_S is set to 12.05V to measure the source current at either G1 or G2.

Note 13: V_1 and V_2 are held at 12V and G1 and G2 are forced to 9V. V_S is set to 12V to measure the source current at either G1 or G2 when the channel is deselected.

Note 14: V_1 and V_2 are held at 12V, $V_S = 11.96\text{V}$ and G1 and G2 have a 4k resistor each to 9V. Measure the delay after the channel is disabled until the gate signal begins to pull high.

TYPICAL PERFORMANCE CHARACTERISTICS

V_{FR} vs Temperature and Supply Voltage

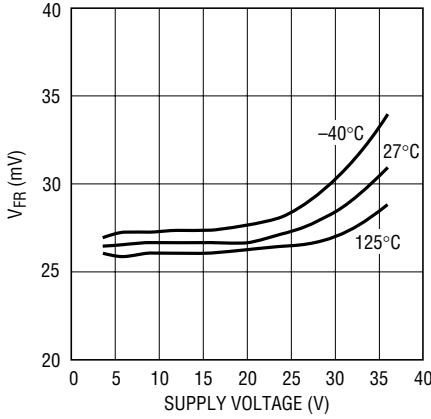

4416 G01

V_{RTO} vs Temperature and Supply Voltage



4416 G02

Normalized Quiescent Supply Current vs Temperature



4416 G03

I_{V1} , I_{V2} and I_{VS} Pin Leakage vs Temperature

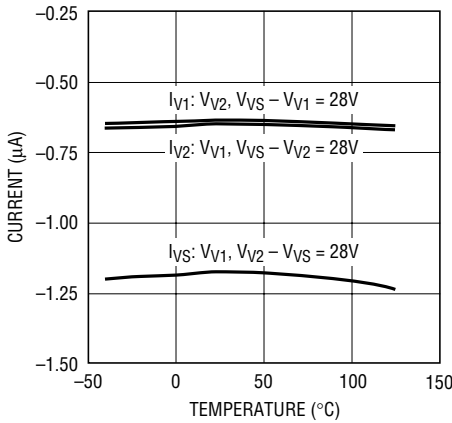

4416 G04

$V_{Gn(ON)}$ vs Temperature and V_{IN}

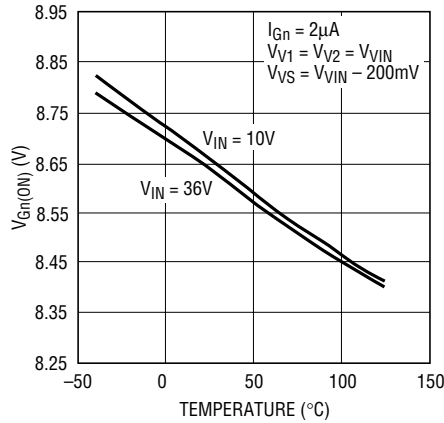

4416 G05

$V_{Gn(OFF)}$ vs Temperature and I_{Gn}

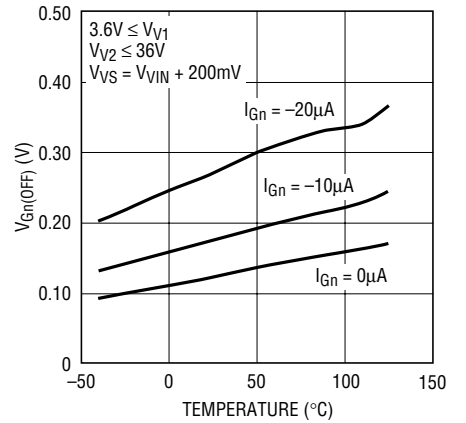

4416 G06

$t_{G(ON)}$ vs Temperature

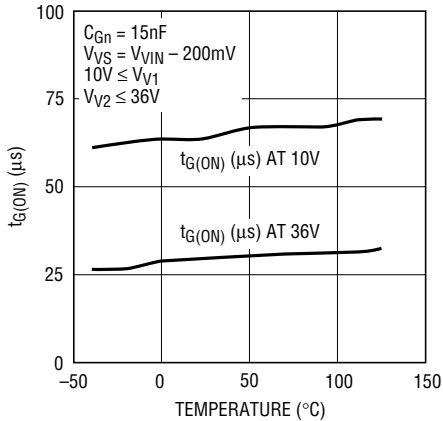

4416 G07

$t_{G(OFF)}$ vs Temperature

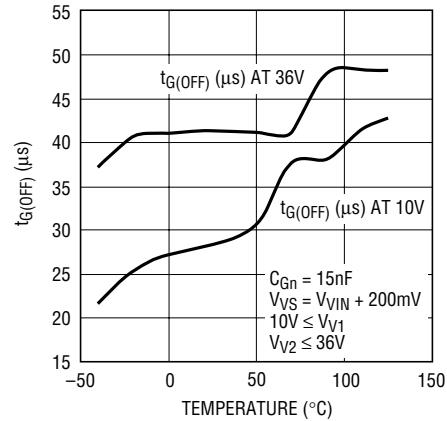

4416 G08

PIN FUNCTIONS

H1 (Pin 1): Open-Drain Comparator Output of the E1 Pin. If $E1 > V_{REF}$, the H1 pin will go high impedance, otherwise the pin will be grounded. The maximum voltage permitted on this pin is 7V. This pin provides support for setting up hysteresis to an external resistor network.

E1 (Pin 2): LTC4416 Comparator Enable Input. A high signal greater than V_{REF} will enable the V1 path. The ideal diode action will then determine if the V1 path should turn on by controlling any PFET(s) connected to the G1 pin. If the E1 signal is driven low, the V1 path will perform a “soft-off” provided the PFET(s) are properly configured for blocking DC current. An internal current sink will pull the E1 pin down when the E1 input exceeds 1.5V.

E1 (Pin 2): LTC4416-1 Comparator Enable Input. A high signal greater than V_{REF} will enable the V1 path. The ideal diode action will then determine if the V1 path should turn on by controlling any PFET(s) connected to the G1 pin. If the E1 signal is driven low, the V1 path will be quickly disabled by enabling the “fast-off” feature, pulling the G1 gate high. An internal current sink will pull the E1 pin down when the E1 input exceeds 1.5V.

GND (Pin 3): Ground. This pin provides a power return path for all the internal circuits.

E2 (Pin 4): LTC4416 Comparator Enable Input. A low signal less than V_{REF} will enable the V2 path. The ideal diode action will then determine if the V2 path should turn on by controlling any PFET(s) connected to the G2 pin. If the E2 signal is driven high, the V2 path will perform a “soft-off” provided the PFET(s) are properly configured for blocking DC current. An internal current sink will pull the E2 pin down when the E2 input exceeds 1.5V.

E2 (Pin 4): LTC4416-1 Comparator Enable Input. A low signal less than V_{REF} will enable the V2 path. The ideal diode action will then determine if the V2 path should turn on by controlling any PFET(s) connected to the G2 pin. If the E2 signal is driven high, the V2 path will be quickly disabled by enabling the “fast-off” feature, pulling the G2 gate high. An internal current sink will pull the E2 pin down when the E2 input exceeds 1.5V.

H2 (Pin 5): Open-Drain Comparator Output of the E2 Pin. If $E2 > V_{REF}$, the H2 pin will go high impedance, otherwise

the pin will be grounded. The maximum voltage permitted on this pin is 7V. This pin provides support for setting up hysteresis to an external resistor network.

G2 (Pin 6): Second P-Channel MOSFET Power Switch Gate Drive Pin. This pin is directed by the second power controller to maintain a forward regulation voltage (V_{FR}) of 25mV between the V2 and V_S pins when V2 is greater than V_S . When V2 is less than V_S , the G2 pin will pull up to the V_S pin voltage, turning off the second P-channel power switch.

V2 (Pin 7): Second Input Supply Voltage. Supplies power to the second power controller and the band-gap reference. V2 is one of the two voltage sense inputs to the second internal power controller (the other input to the second internal power controller is the V_S pin). This input is usually supplied power from the second, or backup, power source. This pin can be bypassed to ground with a capacitor in the range of 0.1 μ F to 10 μ F if needed to suppress load transients.

V_S (Pin 8): Power Sense Input Pin. Supplies power to the internal circuitry of both the first and second power controller and the band-gap reference. This pin is also a voltage sense input to both internal analog controllers (the other input to the first controller is the V1 pin and the other input to the second controller is the V2 pin.) This input may also be supplied power from an auxiliary source which also supplies current to the load.

V1 (Pin 9): First Input Supply Voltage. Supplies power to the first power controller and the band-gap reference. V1 is one of the two voltage sense inputs to the first internal power controller (the other input to the first internal power controller is the V_S pin). This input is usually supplied power from the first, or primary, power source. This pin can be bypassed to ground with a capacitor in the range of 0.1 μ F to 10 μ F if needed to suppress load transients.

G1 (Pin 10): First P-Channel MOSFET Power Switch Gate Drive Pin. This pin is directed by the first power controller to maintain a forward regulation voltage (V_{FR}) of 25mV between the V1 and V_S pins when V1 is greater than V_S . When V1 is less than V_S , the G1 pin will pull up to the V_S pin voltage, turning off the first P-channel power switch.

BLOCK DIAGRAM

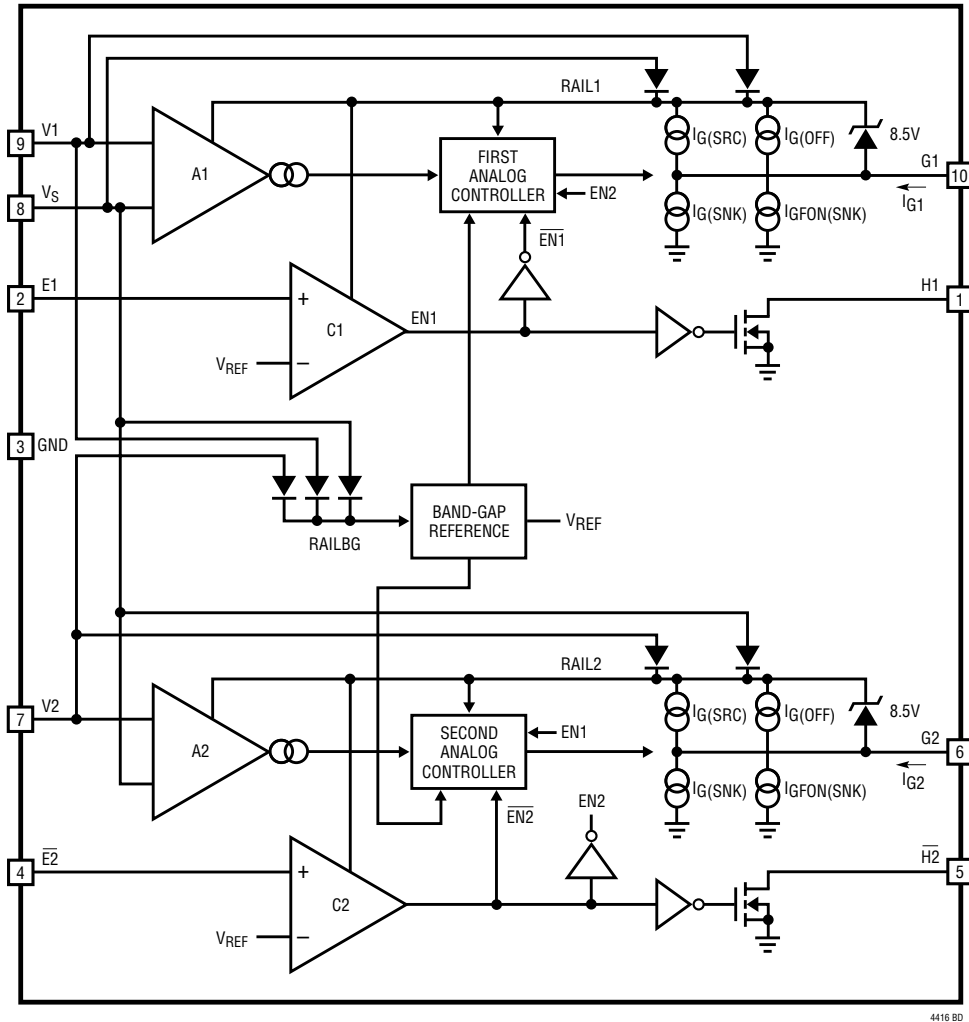

4416 BD

OPERATION

Operation can best be understood by referring to the Block Diagram which illustrates the internal circuit blocks. The LTC4416/LTC4416-1 are divided into three sections, namely:

1. The channel 1 controller consisting of A1, C1, the “first analog controller,” the G1 drivers and the H1 output driver.
2. The band-gap reference
3. The channel 2 controller consisting of A2, C2, the “second analog controller,” the G2 drivers and the H2 output driver.

Each of the three sections has its own derived internal power supply referred to as a rail. RAIL1 provides power to the channel 1 controller. RAIL2 provides power to the channel 2 controller. The internal RAILBG provides power to the band-gap reference. The internal rail1 derives its power from the higher voltage of V1 and Vs. The internal rail2 derives its power from the higher voltage of V2 and Vs. RAILBG derives its power from the highest voltage of V1, V2, and Vs. All three sections share a common ground connected to the GND pin.

4416fa

OPERATION

The band-gap reference provides internal bias currents used by the channel 1 and channel 2 controllers. It also provides a precision voltage reference, V_{REF} , used by comparators C1 and C2. The band-gap reference is powered as long as a minimum operational voltage is present on either V1, V2, or V_S .

The C1 and C2 comparators provide a fixed comparison between the $\overline{E1}$ and $\overline{E2}$ inputs, respectively, and the internal V_{REF} signal. The comparator outputs are directly represented by the H1 and H2 open-drain outputs. The output states of H1 and H2 are not dependent upon the relative voltage difference between $V_{V1} - V_{VS}$ and $V_{V2} - V_{VS}$, respectively. If $V_{\overline{E1}}$ is less than V_{REF} , the H1 open-drain output will be low impedance to GND. If $V_{\overline{E2}}$ is less than V_{REF} , the H2 open-drain output will be low impedance to GND.

The A1 and A2 circuits act both as a high side transconductance amplifiers and as comparators. Both A1 and A2 act identically when the analog controllers are fully enabled. The relationship of the G1 current is represented by Figure 1.

When $V_{V1} - V_{VS} < V_{RTO}$, the A1 activates the reverse turn-off condition and the I_{G1} current is $I_{G(OFF)}$. When $V_{RTO} < V_{V1} - V_{VS} < V_{FR}$, the A1 acts as a class A output and the I_{G1} current is fixed at $I_{G(SRC)}$. As the $V_{V1} - V_{VS}$ voltage

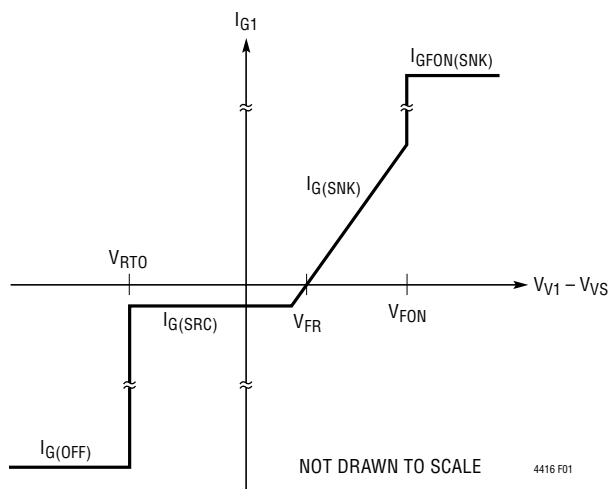

Figure 1. I_{G1} vs $V_{V1} - V_{VS}$

approaches the forward regulation voltage, V_{FR} , the $I_{G(SNK)}$ current will be proportional to $V_{V1} - V_{VS}$. When $V_{V1} - V_{VS} > V_{FON}$, the A1 activates the fast-on condition, $t_{G(ON)}$, and the I_{G1} current is set to $I_{G(FON(SNK))}$.

LTC4416 OPERATION

The interaction of the LTC4416 analog controllers distinguish the operation of the LTC4416 from a simple circuit using two PowerPath controllers. Table 1 explains the different operation modes of the analog controllers.

Table 1. LTC4416 Operational Modes

E1	$\overline{E2}$	Operation Mode	$I_{G(OFF)1}$	$I_{G(OFF)2}$
1	0	Load Sharing	Enabled	Enabled
1	Sense	V1 is Less Than V2	Enabled	
Sense	0	V1 is Greater Than V2		Enabled
0	X	Channel 1 Disabled. Do Not Use	Disabled	
X	1	Channel 2 Disabled. Do Not Use		Disabled
0	1	Both Channels Disabled	Disabled	Disabled

The LTC4416 has six modes of operation. Each mode of operation is dependent upon the configuration of the E1 and $\overline{E2}$ input pins.

Load Sharing Operation

The load sharing mode configures the LTC4416 into two independent PowerPath controllers. This is accomplished by fully enabling both the first analog controller and the second analog controller. Both channels will implement the gate drive outlined in Figure 1.

V1 is Less Than V2 Operation

Channel 1 is fully enabled. If $V_{V1} - V_{VS} < V_{RTO}$, channel 1 will implement all of the I_{G1} currents listed in Figure 1.

When $V_{\overline{E2}}$ is above the V_{REF} threshold, channel 2 is in a "soft-off mode". This means that G2 will only provide an $I_{G(SRC)}$ current instead of either an $I_{G(SRC)}$ or an $I_{G(OFF)}$ current.

When $V_{\overline{E2}}$ is below the V_{REF} threshold, channel 2 is fully enabled, and G2 will become active implementing the I_G output current listed in Figure 1.

OPERATION

V1 is Greater Than V2 Operation

When V_{E1} is below the V_{REF} threshold, channel 1 is in a “soft-off mode”. This means that G1 will only provide an $I_{G(SRC)}$ current instead of an $I_{G(SNK)}$ or an $I_{GFON(SNK)}$ current.

When V_{E1} is above the V_{REF} threshold, channel 1 is immediately fully enabled, and G1 will become active implementing the output current listed in Figure 1.

Channel 2 is fully enabled. If $V_{V1} - V_{VS} < V_{RTO}$, channel 2 will implement all of the I_{G2} currents listed in Figure 1.

Channel 1 is Disabled

The LTC4416 is not designed to have channel 1 disabled by grounding E1 and leaving $\overline{E2}$ in an indeterminate state. If this happens, the channel 2 PowerPath controller will not have reverse turn-off capability. No electrical harm to the LTC4416 will occur.

Channel 2 is Disabled

The LTC4416 is not designed to have channel 2 disabled by connecting E2 high and leaving E1 in an indeterminate state. If this happens, the channel 1 PowerPath controller will not have reverse turn-off capability. No electrical harm to the LTC4416 will occur.

Both Channels Disabled

When both channels of the LTC4416 are disabled, both G1 and G2 currents are set to $I_{G(SRC)}$.

LTC4416-1 OPERATION

The LTC4416-1 is designed for overvoltage/undervoltage protection or when either voltage path must be turned off rapidly, regardless of the status of the other voltage input. The LTC4416-1 does not implement the soft-off feature implemented in the LTC4416. The E1 and $\overline{E2}$ inactive will force the I_G current of their respective channel to $I_{G(OFF)}$. Table 2 explains the operation of the E1 and E2 inputs. The term “active” implies that $I_{G(OFF)}$ current is forced on the Gn pins regardless of the $V_{Vn} - V_{VS}$ value. The term “enabled” implies that $I_{G(OFF)}$ current is provide on the Gn pins if and only if $V_{Vn} - V_{VS} < V_{RTO}$.

Table 2 LTC4416-1 Operational Modes

E1	$\overline{E2}$	Operation Mode	$I_{G(OFF)1}$	$I_{G(OFF)2}$
0	X	Undervoltage Protection	Active	
X	1	Overvoltage Protection		Active
1	X	Channel 1 PowerPath	Enabled	
X	0	Channel 2 PowerPath		Enabled

APPLICATIONS INFORMATION

LTC4416

The LTC4416 is designed to support three major applications. The first two applications assume that V1 is the primary power source and V2 is the backup power source. The first application is where the V1 power supply is normally less than V2. The second application is where the V1 power supply is normally greater than V2. The third application addresses the load sharing case where both V1 and V2 are relatively equal in value.

V1 is Less Than V2

Figure 2 illustrates the external resistor configuration for this case.

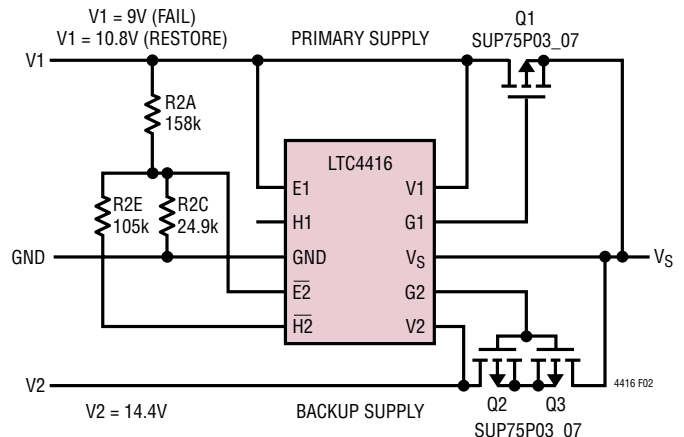

Figure 2

APPLICATIONS INFORMATION

This configuration would be used where V1 is a 12V power supply and the V2 power supply is a 4-cell Li-Ion battery pack. When V1 is 12V, $\overline{E2}$ disables the V2 source from being connected to V_S through Q2A and Q2B by forcing G2 to V2, $\overline{H2}$ is open circuit. E1 is connected to a voltage greater than the V_{REF} to keep the V1 to V_S path active. The V_S output can be shut completely off by grounding the E1 input. The LTC4416 takes its power from the higher of V1, V2 and V_S . This configuration will provide power from V1 to V_S until the V1 supply drops below 9V.

When V1 drops below 9V, the $\overline{H2}$ pin closes to GND, G2 drops to a V_{CLAMP} below V2 and G1 rises to the V_S voltage level. V2 will supply current to V_S until V1 rises above 10.8V. The H1 output will be open until the E1 input drops below the V_{REF} voltage level.

The V1 V_{FAIL} is determined by:

$$\begin{aligned} V_{FAIL} &= V_{ETH} \cdot \frac{R2A + R2C}{R2C} \\ &= 1.222V \cdot \frac{158k + 24.9k}{24.9k} = 8.98V \end{aligned}$$

The V1 $V_{RESTORE}$ is determined by:

$$\begin{aligned} V_{RESTORE} &= V_{ETH} \cdot \frac{(R2A + (R2C \parallel R2E))}{R2C \parallel R2E} \\ &= 1.222V \cdot \frac{158k + (24.9k \parallel 105k)}{24.9k \parallel 105k} = 10.81V \end{aligned}$$

V1 is Greater Than V2

Figure 3 illustrates the external resistor configuration for this case.

This configuration would be used where V1 is a 12V power supply and the V2 power supply is a 3-cell Li-Ion battery pack. When V1 is 16V, E1 enables the V1 source as being the primary supply, thus disabling the V2 supply since $V1 > V2$. When $E1 > V_{REF}$, the H1 output is open. The V_S output can be shut completely off by grounding the H1 input and forcing $E2 > V_{REF}$. The LTC4416 takes its power from the higher of V1, V2 and V_S . This configuration will provide power from V1 to V_S until the V1 supply drops below 12V.

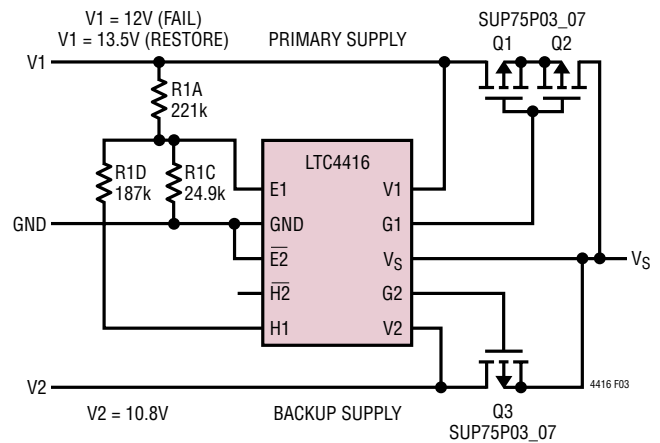

Figure 3

When V1 drops below 12V, the H1 pin closes to GND, G2 drops to a V_{CLAMP} below V2 and G1 rises to the V1 voltage level. V2 will supply current to V_S until V1 rises above 13.5V. The H2 output will be shorted to GND until the $\overline{E2}$ input goes above the V_{REF} voltage level.

The V1 V_{FAIL} is determined by:

$$\begin{aligned} V_{FAIL} &= V_{ETH} \cdot \frac{R1A + R1C}{R1C} \\ &= 1.222V \cdot \frac{221k + 24.9k}{24.9k} = 12.07V \end{aligned}$$

The V1 $V_{RESTORE}$ is determined by:

$$\begin{aligned} V_{RESTORE} &= V_{ETH} \cdot \frac{(R1A + (R1C \parallel R1D))}{R1C \parallel R1D} \\ &= 1.222V \cdot \frac{221k + (24.9k \parallel 187k)}{24.9k \parallel 187k} = 13.51V \end{aligned}$$

Load Sharing

Figure 4 illustrates the configuration for this case.

This configuration would be used where V1 and V2 are relatively the same voltage. In this case the LTC4416 acts as two interconnected ideal diode controllers. V_S will be supplied by the higher of the two supplies, V1 and V2. If V1 and V2 are exactly the same, then 50% of the current for V_S will be supplied by each supply. As the two supplies

APPLICATIONS INFORMATION

differ by more than 100mV, 100% of the load will come from the higher of V1 or V2.

The user has the option of using E1 and $\bar{E}2$ to disable one of the two supplies by connecting them to a digital controller. If E1 is brought low, V1 will no longer supply current to V_S . If E2 is brought high, V2 will no longer supply current to V_S . If E1 is brought low and $\bar{E}2$ is brought high, V_S will be disabled.

Figure 5 shows the same application without the shutdown option. It has one-half the losses of Figure 4 and is configured for 5V rails.



Figure 4



Figure 5. Dual PowerPath for Current Sharing

LTC4416-1

The LTC4416-1 will support all three of the LTC4416 applications without the “soft-off” feature. The only difference in the two designs is the LTC4416-1 will rapidly switch off the load from a supply whenever a channel is

disabled. This rapid turn-off feature is desirable when the supply cannot tolerate certain voltage excursions under load, or when the load is being protected from a rapidly changing input supply.

Under and Overvoltage Shutdown

Refer to Figure 6 for an application circuit which disables the power to the load when the input voltage gets too low or too high. When V_{IN} starts from zero volts, the load to the output is disabled until V_{IN} reaches 5.5V. The V1 path is enabled and the load remains on the input until the supply exceeds 13.5V. At that voltage, the V2 path is disabled. As the input falls, the voltage source will be reconnected to the load when the input drops to 12V and the V2 path is enabled. Finally, the load will be removed from the input supply when the voltage drops below 5V.

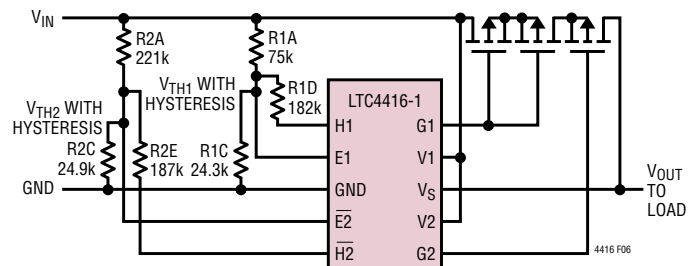

UV ENABLED AT 5V, V_{IN} RESTORED TO LOAD WHEN V_{IN} RISES TO 5.5V
OV ENABLED AT 13.5V, V_{IN} RESTORED TO LOAD WHEN V_{IN} FALLS TO 12V

Figure 6

Undervoltage

$$V_{\text{FAIL}} = V_{\text{ETH}} \cdot \frac{R1A + R1C}{R1C}$$

$$= 1.222\text{V} \cdot \frac{75\text{k} + 24.3\text{k}}{24.3\text{k}} = 4.99\text{V}$$

$$V_{\text{RESTORE}} = V_{\text{ETH}} \cdot \frac{(R1A + (R1C \parallel R1D))}{R1C \parallel R1D}$$

$$= 1.222\text{V} \cdot \frac{75\text{k} + (24.3\text{k} \parallel 182\text{k})}{24.3\text{k} \parallel 182\text{k}} = 5.497\text{V}$$

APPLICATIONS INFORMATION

Overvoltage

$$V_{\text{FAIL}} = V_{\text{ETH}} \cdot \frac{R2A + R2C \parallel R2E}{R2C \parallel R2E}$$

$$= 1.222\text{V} \cdot \frac{221\text{k} + 24.9\text{k} \parallel 187\text{k}}{24.9\text{k} \parallel 187\text{k}} = 13.51\text{V}$$

$$V_{\text{RESTORE}} = V_{\text{ETH}} \cdot \frac{R2A + R2C}{R2C}$$

$$= 1.222\text{V} \cdot \frac{221\text{k} + 24.9\text{k}}{24.9\text{k}} = 12.07\text{V}$$

The over and undervoltage lockout circuits are shown here working in tandem. It is possible to configure the circuit for either over or undervoltage lockout by using only one of the voltage paths and eliminating the components from the other. Refer to Figure 7 for an LTC4416-1 configured for overvoltage protection. If the input does not go below ground, transistor Q1 can be eliminated.

The LTC4416-1 should be used in this configuration rather than the LTC4416 because the LTC4416-1 will turn-off rapidly if an over or undervoltage condition is detected. Refer to Figure 8 for a comparison of the transient response of the two ICs using the circuit configuration of Figure 6. The LTC4416 will not turn-off quickly in an overvoltage or undervoltage condition because the “fast-off” feature is not enabled. This will cause the output to travel beyond the desired range.

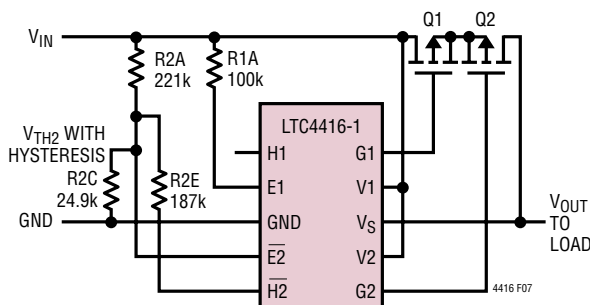

Figure 7. LTC4416-1 Configured for Overvoltage Protection

Figure 9 contains a rapidly changing input voltage on a much smaller time scale in comparison to Figure 8. The LTC4416 will require the $t_{E(\text{OFF})}$ time prior to the rapid pull-up current being applied. The gate voltage will be pulled high with $I_{G(\text{OFF})}$ which has a minimum current of $500\mu\text{A}$. The discharge time of the gate will be dependent on the capacitance of the external FET and the initial gate-source voltage of the circuit. The total time delay will equal:

$$t_{\text{DELAY}} = t_{E(\text{OFF})} + t_{\text{DISCHARGE}}$$

$$= t_{E(\text{OFF})} + \frac{C_{\text{GS}} \cdot \Delta V}{I_{G(\text{OFF})}}$$



Figure 8. Transient Response of the LTC4416 vs the LTC4416-1 Light Load with a Large Capacitor on VOUT

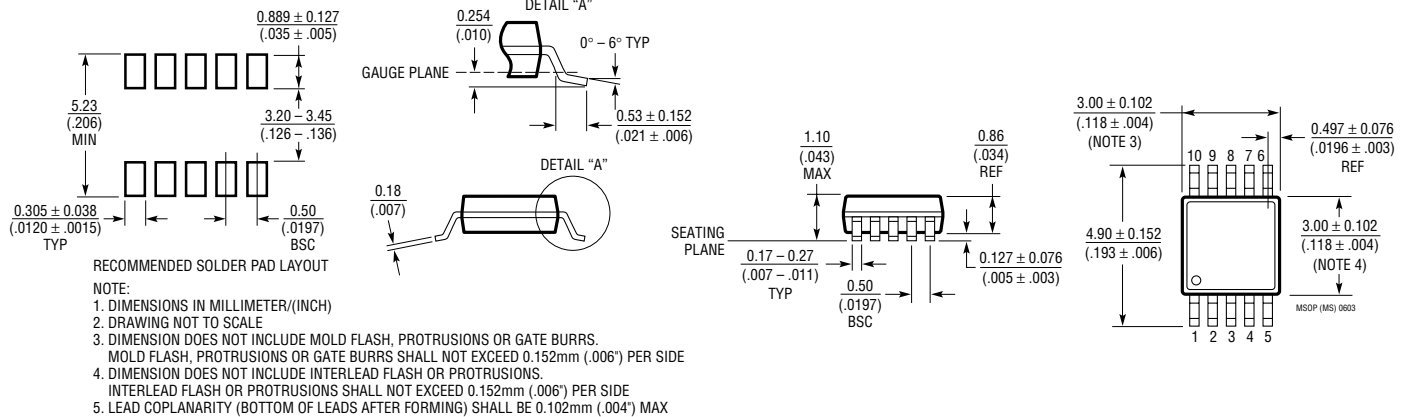

Figure 9. Close Up of the Transient Response of the LTC4416-1 to a Rapidly Rising Input

LTC4416/LTC4416-1

PACKAGE DESCRIPTION

MS Package 10-Lead Plastic MSOP (Reference LTC DWG # 05-08-1661)



RELATED PARTS

PART NUMBER	DESCRIPTION	COMMENTS
LTC1473	Dual PowerPath Switch Driver	Switches and Isolates Sources Up to 30V
LTC1479	PowerPath Controller for Dual Battery Systems	Complete PowerPath Management for Two Batteries; DC Power Source, Charger and Backup
LTC1558/LTC1559	Back-Up Battery Controller with Programmable Output	Adjustable Backup Voltage from 1.2V NiCd Button Cell, Includes Boost Converter
LT®1579	300mA Dual Input Smart Battery Back-Up Regulator	Maintains Output Regulation with Dual Inputs, 0.4V Dropout at 300mA
LTC1733/LTC1734	Monolithic Linear Li-Ion Chargers	Thermal Regulation, No External MOSFET/Sense Resistor
LTC1998	2.5µA, 1% Accurate Programmable Battery Detector	Adjustable Trip Voltage/Hysteresis, ThinSOT™
LTC4055	USB Power Controller and Li-Ion Linear Charger	Automatic Battery Switchover, Thermal Regulation, Accepts Wall Adapter and USB Power, 4mm × 4mm QFN
LTC4066	USB Power Controller and Battery Charger	Charges Single Cell Li-Ion Batteries Directly from a USB Port, Thermal Regulation, 50mΩ Ideal Diode, 4mm × 4mm QFN24 Package
LTC4085	USB Power Manager with Ideal Diode Controller and Li-Ion Charger	Charges Single Cell Li-Ion Batteries Directly from a USB Port, Thermal Regulation, 200mΩ Ideal Diode <50mΩ Option, 4mm × 3mm DFN14 Package
LTC4354	Negative Voltage Diode-OR Controller and Monitor	Replaces Power Schottky Diodes; 80V Operation
LTC4410	USB Power Manager in ThinSOT	Enables Simultaneous Battery Charging and Operation of USB Component Peripheral Devices
LTC4411	SOT-23 Ideal Diode	2.6A Forward Current, 28mV Regulated Forward Voltage
LTC4412HV	36V, Low Loss PowerPath Controller in MSOP	-40°C to -125°C Operation; Automatic Switching Between DC Sources
LTC4413	Dual 2.6A, 2.5V to 5.5V Ideal Diodes in 3mm × 3mm DFN	100mΩ ON Resistance, 1µA Reverse Leakage Current, 28mV Regulated Forward Voltage
LTC4414	36V, Low Loss PowerPath Controller for Large PFETs	Drives Large Q _G PFETs, Very Low Loss Replacement for Power Supply O'Ring Diodes, 3.5V to 36V AC/DC Adapter Voltage Range, MSOP-8 Package

ThinSOT is a trademark of Linear Technology Corporation.

4416fa

X-ON Electronics

Largest Supplier of Electrical and Electronic Components

Click to view similar products for [Power Management Specialised - PMIC category:](#)

Click to view products by [Analog Devices manufacturer:](#)

Other Similar products are found below :

[P9145-I0NQGI](#) [SLG7NT4192VTR](#) [AS3729B-BWLM](#) [LNBH25SPQR](#) [ADP5080ACBZ-1-RL](#) [MC32PF3000A6EP](#) [MB39C831QN-G-EFE2](#)
[MAX9959DCCQ+D](#) [MAX1932ETC+T](#) [MAX1856EUB+T](#) [STNRG011TR](#) [IRPS5401MXI03TRP](#) [S6AE102A0DGN1B200](#)
[MMPF0100FDAEP](#) [MCZ33903DS5EK](#) [S6AE101A0DGNAB200](#) [MAX17117ETJ+](#) [L9916](#) [L9915-CB](#) [MCZ33905DS3EK](#)
[MMPF0100FCANES](#) [MMPF0100FBANES](#) [WM8325GEFL/V](#) [MCZ33903DP5EK](#) [MCZ33905DS5EK](#) [MCZ33903DD5EK](#) [ADN8835ACPZ-](#)
[R7](#) [MCZ33903DP5EKR2](#) [MCZ33903DD3EK](#) [MMPF0100FAAZES](#) [SLG7NT4198V](#) [MIC5164YMM](#) [P9180-00NHGI](#) [TLE9261QX](#)
[TEA1998TS/1H](#) [MAX881REUB+T](#) [TLE9262QX](#) [TLE8880TN](#) [MAX8520ETP+T](#) [SLG7NT4083V](#) [ADP1031ACPZ-1-R7](#) [ADP1031ACPZ-2-](#)
[R7](#) [ADP1031ACPZ-3-R7](#) [ADP1031ACPZ-4-R7](#) [ADP1031ACPZ-5-R7](#) [L9788TR](#) [STPMIC1APQR](#) [STPMIC1BPQR](#) [STPMIC1CPQR](#)
[LT6110HTS8#TRMPBF](#)