

**INTELLIGENT POWER HIGH SIDE SWITCH**

**Features**

- Over temperature shutdown (with auto-restart)
- Short circuit protection (current limit)
- Reverse battery protection (turns On the MOSFET)
- Full diagnostic capability (short circuit to battery)
- Active clamp
- Open load detection in On and Off state
- Ground loss protection
- Logic ground isolated from power ground
- ESD protection

**Description**

The IPS6011(S)(R)PbF is a five terminal Intelligent Power Switch (IPS) for use in a high side configuration. It features short circuit, over-temperature, ESD protection, inductive load capability and diagnostic feedback. The output current is limited to the Ilim value. The current limitation is activated until the thermal protection acts. The over-temperature protection turns off the device if the junction temperature exceeds the Tshutdown value. It will automatically restart after the junction has cooled 7°C below the Tshutdown value. The reverse battery protection turns On the MOSFET. A diagnostic pin provides different voltage levels for each fault condition. The double level shifter circuitry will allow large offsets between the logic and load ground.

**Product Summary**

|           |           |
|-----------|-----------|
| Rds(on)   | 14mΩ max. |
| Vclamp    | 39V       |
| I Limit   | 60A       |
| Open load | 3V / 2.4A |

**Packages**

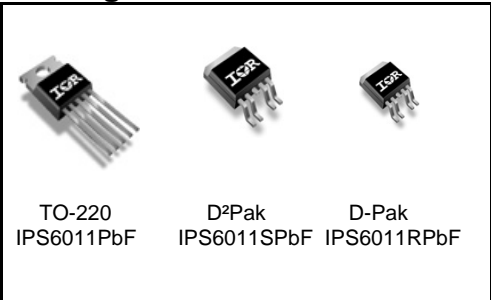

**Typical Connection**

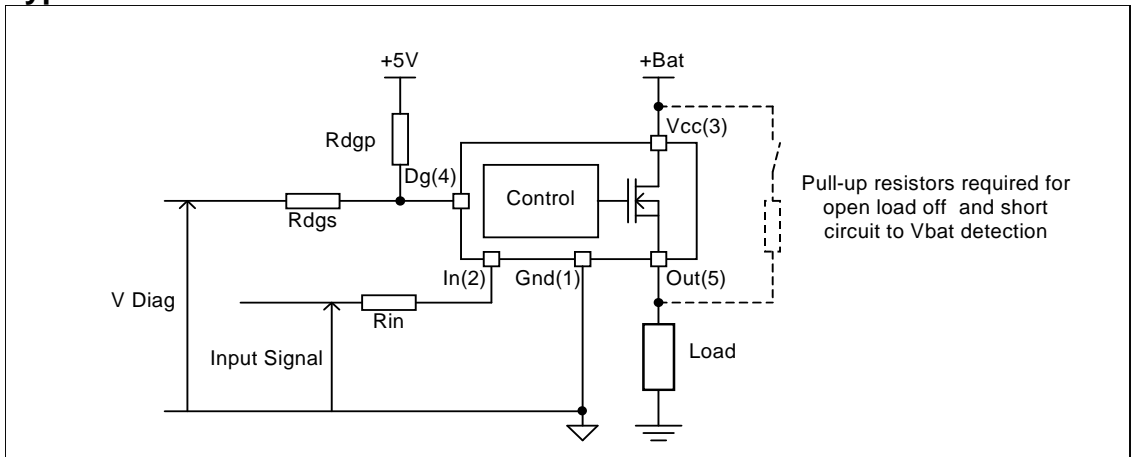

## Absolute Maximum Ratings

Absolute maximum ratings indicate sustained limits beyond which damage to the device may occur. All voltage parameters are referenced to Ground lead. (Tambient=25°C unless otherwise specified).

| Symbol                 | Parameter   | Min.                                   | Max.    | Units |     |
|------------------------|---|--|---------|-------|-----|
| Vout                   | Maximum output voltage  | Vcc-35                                 | Vcc+0.3 | V     |     |
| Voffset                | Maximum logic ground to load ground offset  | Vcc-35                                 | Vcc+0.3 |       |     |
| Vin                    | Maximum input voltage   | -0.3                                   | 5.5     |       |     |
| Vcc max.               | Maximum Vcc voltage   | —                                      | 36      |       |     |
| Vcc cont.              | Maximum continuous Vcc voltage  | —                                      | 28      |       |     |
| Vcc sc.                | Maximum Vcc voltage with short circuit protection   | —                                      | 24      |       |     |
| Iin max.               | Maximum IN current  | -3                                     | 10      | mA    |     |
| I <sub>dg</sub> max.   | Maximum diagnostic output current   | -3                                     | 10      |       |     |
| V <sub>dg</sub>        | Maximum diagnostic output voltage   | -0.3                                   | 5.5     | V     |     |
| Pd                     | Maximum power dissipation (internally limited by thermal protection)<br>Rth=5°C/W IPS6011                         | —                                      | 25      | W     |     |
|                        |   | Rth=40°C/W IPS6011S 1" sqrt. footprint | —       |       | 3.1 |
|                        |   | Rth=50°C/W IPS6011R 1" sqrt. footprint | —       |       | 2.5 |
| ESD                    | Electrostatic discharge voltage (Human body) C=100pF, R=1500Ω<br>Between In and Vcc<br>Other combinations         | —                                      | 1500    | V     |     |
|                        |   | —                                      | 4000    |       |     |
|                        | Electrostatic discharge voltage (Machine Model) C=200pF, R=0Ω, L=10μH<br>Between In and Vcc<br>Other combinations | —                                      | 100     |       |     |
|                        |   | —                                      | 500     |       |     |
| T <sub>j</sub> max.    | Max. storage & operating temperature junction temperature   | -40                                    | 150     | °C    |     |
| T <sub>soldering</sub> | Soldering temperature (10 seconds)  | —                                      | 300     | °C    |     |

## Thermal Characteristics

| Symbol | Parameter   | Typ. | Max. | Units |
|--------|---|------|------|-------|
| Rth1   | Thermal resistance junction to ambient IPS6011 TO220 free air                         | 50   | —    | °C/W  |
| Rth2   | Thermal resistance junction to case IPS6011 TO220                                     | 1.2  | —    |       |
| Rth1   | Thermal resistance junction to ambient IPS6011S D <sup>2</sup> Pak std. footprint     | 60   | —    |       |
| Rth2   | Thermal resistance junction to ambient IPS6011S D <sup>2</sup> Pak 1" sqrt. footprint | 40   | —    |       |
| Rth3   | Thermal resistance junction to case IPS6011S D <sup>2</sup> Pak                       | 1.2  | —    |       |
| Rth1   | Thermal resistance junction to ambient IPS6011R D-Pak std. footprint                  | 70   | —    |       |
| Rth2   | Thermal resistance junction to ambient IPS6011R D-Pak 1" sqrt. footprint              | 50   | —    |       |
| Rth3   | Thermal resistance junction to case IPS6011R D-Pak                                    | 1.2  | —    |       |

## Recommended Operating Conditions

These values are given for a quick design. For operation outside these conditions, please consult the application notes.

| Symbol            | Parameter  | Min. | Max.             | Units |
|-------------------|--|------|------------------|-------|
| V <sub>IH</sub>   | High level input voltage   | 4    | 5.5              |       |
| V <sub>IL</sub>   | Low level input voltage  | 0    | 0.9              |       |
| I <sub>out</sub>  | Continuous drain current, Tambient=85°C, T <sub>j</sub> =125°C, V <sub>in</sub> =5V<br>Rth=5°C/W IPS6011<br>Rth=40°C/W IPS6011S 1" sqrt. footprint<br>Rth=50°C/W IPS6011R 1" sqrt. footprint | —    | 18<br>6.3<br>5.6 | A     |
| R <sub>in</sub>   | Recommended resistor in series with IN pin   | 4    | 10               | kΩ    |
| R <sub>dg</sub> s | Recommended resistor in series with DG pin for reverse battery protection  | 4    | 20               |       |
| R <sub>dg</sub> p | Recommended pull-up resistor for DG  | 4    | 20               |       |
| R <sub>ol</sub>   | Recommended pull-up resistor for open load detection   | 5    | 100              |       |
| F max.            | Max. switching frequency   | —    | 0.3              |       |

## Static Electrical Characteristics

T<sub>j</sub>=25°C, V<sub>cc</sub>=14V (unless otherwise specified)

| Symbol               | Parameter   | Min. | Typ. | Max. | Units | Test Conditions                            |
|----------------------|---|------|------|------|-------|--|
| R <sub>ds(on)</sub>  | ON state resistance T <sub>j</sub> =25°C                      | —    | 11   | 14   | mΩ    | V <sub>in</sub> =5V, I <sub>out</sub> =20A |
|                      | ON state resistance T <sub>j</sub> =150°C                     | —    | 19.5 | 25   |       | V <sub>in</sub> =5V, I <sub>out</sub> =20A |
|                      | ON state resistance T <sub>j</sub> =25°C, V <sub>cc</sub> =6V | —    | 12   | 17   |       | V <sub>in</sub> =5V, I <sub>out</sub> =20A |
|                      | ON state resistance during reverse battery                    | —    | 15   | 20   |       | V <sub>cc</sub> -Gnd=14V                   |
| V <sub>cc op.</sub>  | Operating voltage range with short circuit protection         | 6    | —    | 24   | V     |  |
| V clamp 1            | V <sub>cc</sub> to Out clamp voltage 1                        | 37   | 39   | —    |       | I <sub>out</sub> =50mA                     |
| V clamp 2            | V <sub>cc</sub> to Out clamp voltage 2                        | —    | 40   | 42   |       | I <sub>out</sub> =16A (see Fig. 1)         |
| I <sub>cc Off</sub>  | Supply current when Off                                       | —    | 4    | 9    | μA    | V <sub>in</sub> =0V, V <sub>out</sub> =0V  |
| I <sub>cc On</sub>   | Supply current when On  | —    | 2.2  | 5    | mA    | V <sub>in</sub> =5V                        |
| V <sub>ih</sub>      | Input high threshold voltage                                  | —    | 2.5  | 2.9  | V     |  |
| V <sub>il</sub>      | Input low threshold voltage                                   | 1.5  | 2    | —    |       |  |
| I <sub>n hyst.</sub> | Input hysteresis  | 0.2  | 0.5  | 1    |       |  |
| I <sub>in On</sub>   | Input current when device is On                               | —    | 40   | 100  |       |  |
| I <sub>dg</sub>      | Dg leakage current  | —    | 0.1  | 10   | μA    | V <sub>in</sub> =5V                        |
| V <sub>dg</sub>      | Low level DG voltage  | —    | 0.25 | 0.4  | V     | I <sub>dg</sub> =1.6mA                     |

## Switching Electrical Characteristics

V<sub>cc</sub>=14V, Resistive load=1Ω, V<sub>in</sub>=5V, T<sub>j</sub>=25°C

| Symbol            | Parameter  | Min. | Typ. | Max. | Units | Test Conditions |
|-------------------|--|------|------|------|-------|-----------------|
| T <sub>don</sub>  | Turn-on delay time                                   | —    | 30   | 60   | μs    | see Fig. 3      |
| Tr1               | Rise time to V <sub>out</sub> =V <sub>cc</sub> -5V   | —    | 25   | 50   |       |                 |
| Tr2               | Rise time to V <sub>out</sub> =0.9 x V <sub>cc</sub> | —    | 40   | 100  |       |                 |
| dV/dt (On)        | Turn On dV/dt  | —    | 0.3  | 0.8  | V/μs  |                 |
| E <sub>On</sub>   | Turn On energy                                       | —    | 4    | —    | mJ    |                 |
| T <sub>doff</sub> | Turn-off delay time                                  | —    | 70   | 140  | μs    |                 |
| T <sub>f</sub>    | Fall time to V <sub>out</sub> =0.1 x V <sub>cc</sub> | —    | 30   | 80   |       |                 |
| dV/dt (Off)       | Turn Off dV/dt                                       | —    | 0.7  | 2    |       |                 |
| E <sub>Off</sub>  | Turn Off energy                                      | —    | 1.5  | —    | mJ    |                 |

## Protection Characteristics

| Symbol  | Parameter                          | Min.   | Typ. | Max. | Units | Test Conditions |
|---------|------------------------------------|--------|------|------|-------|-----------------|
| Ilim    | Internal current limit             | 35     | 60   | 85   | A     | Vout=0V         |
| Tsd+    | Over temperature high threshold    | 150(1) | 165  | —    | °C    | See fig. 2      |
| Tsd-    | Over temperature low threshold     | —      | 158  | —    |       |                 |
| Vsc     | Short-circuit detection voltage(2) | 2      | 3    | 4    | V     |                 |
| UV+     | High undervoltage lockout          | —      | 5    | 5.9  |       |                 |
| UV-     | Low undervoltage lockout           | 3.2    | 4.4  | 5.8  |       |                 |
| VOL Off | Open load detection threshold      | 2      | 3    | 4    |       |                 |
| I OL On | Open load detection threshold      | 0.5    | 1.6  | 2.4  | A     |                 |

(1) Guaranteed by design

(2) Reference to Vcc

## True Table

| Operating Conditions     | IN | OUT | DG    |
|--------------------------|----|-----|-------|
| Normal                   | H  | H   | H     |
| Normal                   | L  | L   | H     |
| Open Load                | H  | H   | L     |
| Open Load (3)            | L  | H   | L     |
| Short circuit to Gnd     | H  | L   | L     |
| Short circuit to Gnd     | L  | L   | H     |
| Short circuit to Vcc     | H  | H   | L (4) |
| Short circuit to Vcc (5) | L  | H   | L     |
| Over-temperature         | H  | L   | L     |
| Over-temperature         | L  | L   | H     |

(3) With a pull-up resistor connected between the output and Vcc.

(4) Vds lower than 10mV.

(5) Without a pull-up resistor connected between the output and Vcc.

## Lead Assignments

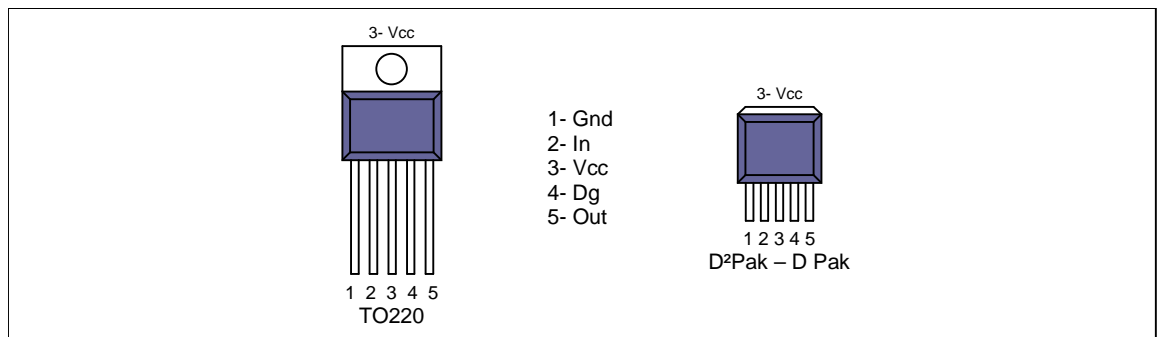

## Functional Block Diagram

All values are typical

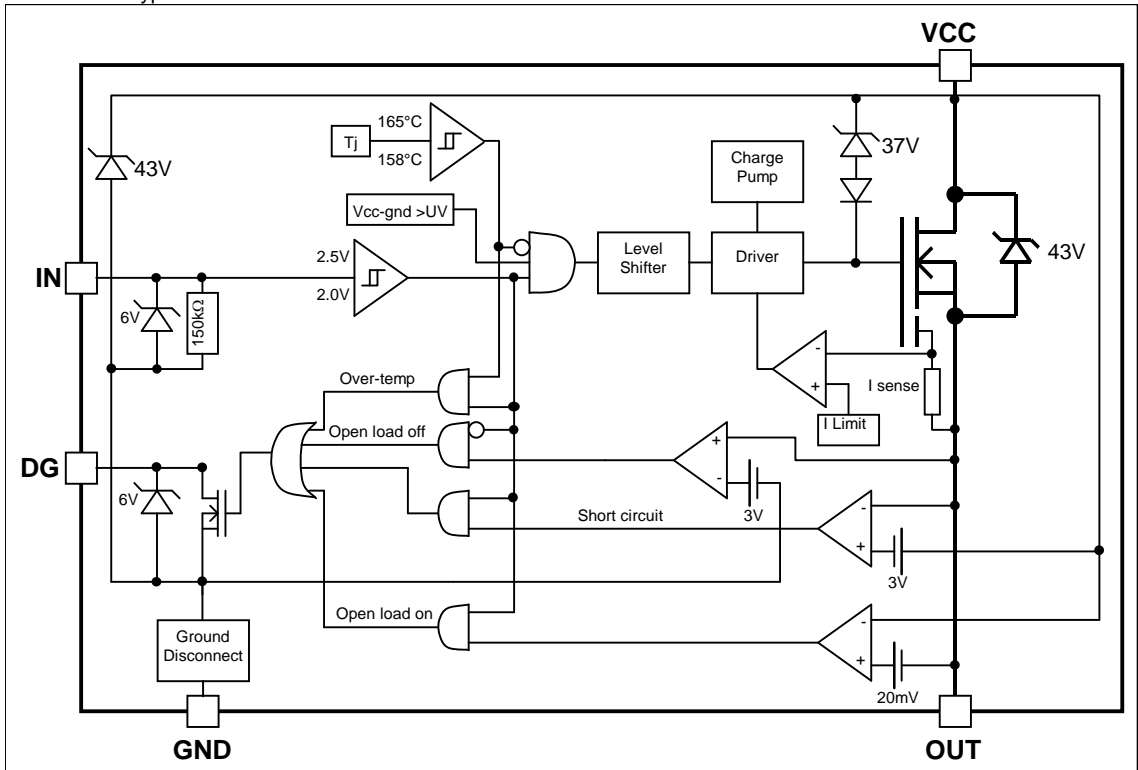

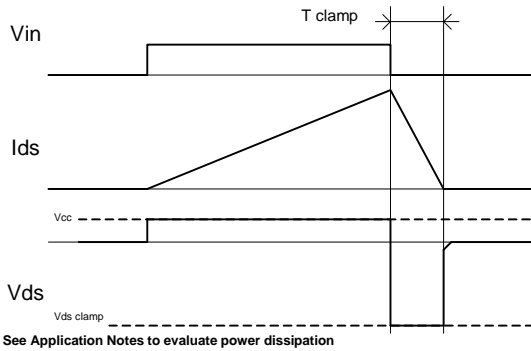

Figure 1 – Active clamp waveforms

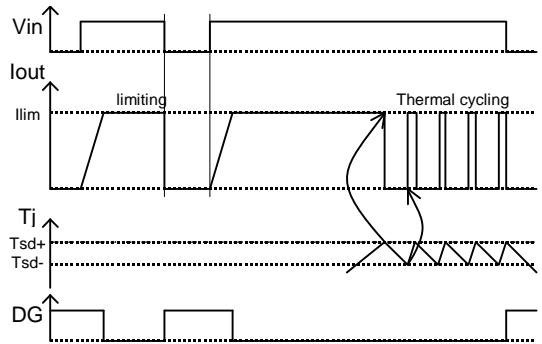

Figure 2 – Protection timing diagram

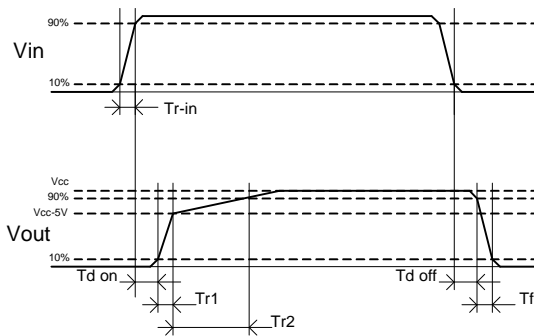

Figure 3 – Switching times definitions

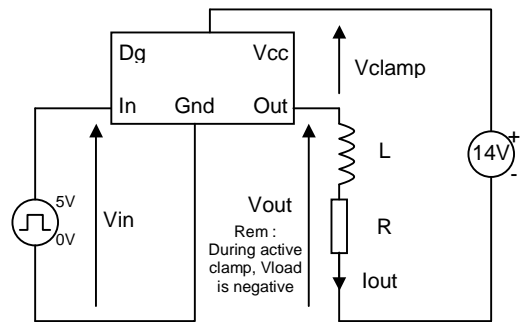
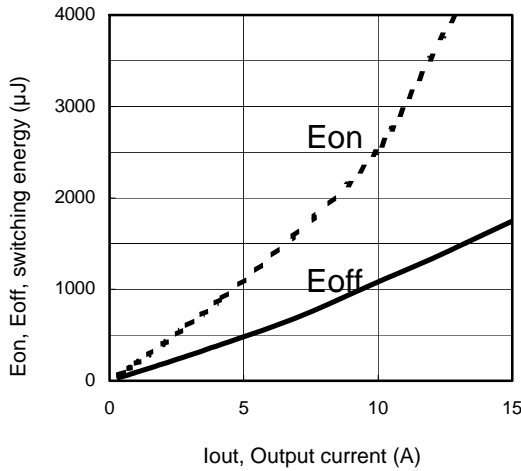
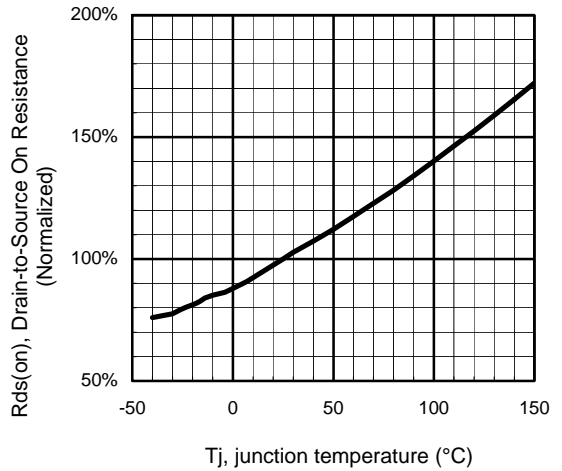

Figure 4 – Active clamp test circuit



**Figure 5 – Switching energy (μJ) Vs Output current (A)**



**Figure 6 - Normalized R<sub>ds(on)</sub> (%) Vs T<sub>j</sub> (°C)**

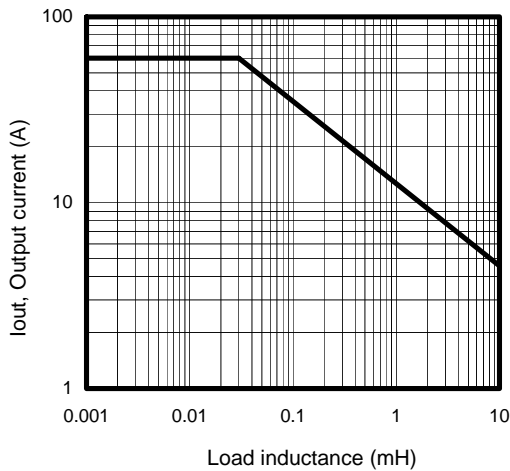

**Figure 7 – Max. Output current (A) Vs Load inductance (mH)**

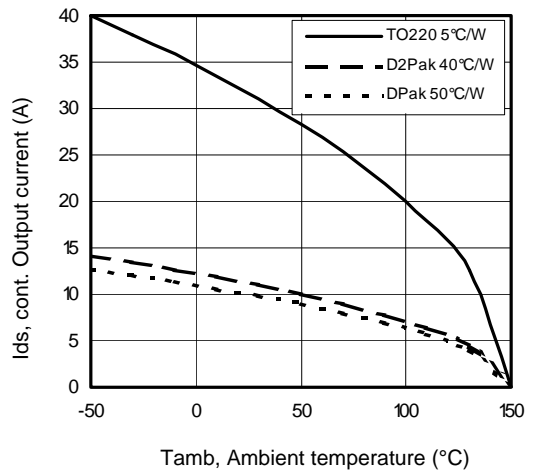

**Figure 8 – Max. output current (A) Vs Ambient temperature (°C)**

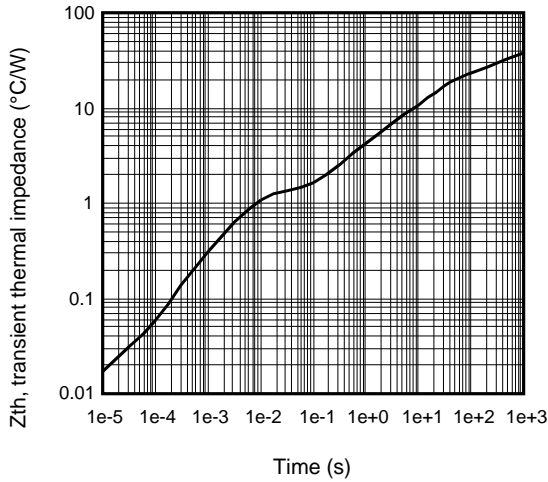

**Figure 9 – Transient thermal impedance (°C/W) Vs time (s)**

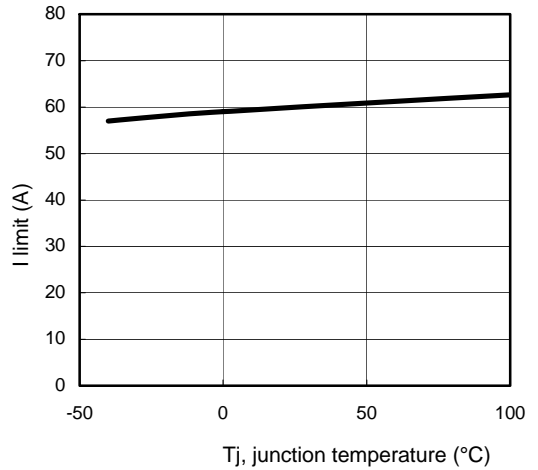

**Figure 10 – I limit (A) Vs junction temperature (°C)**

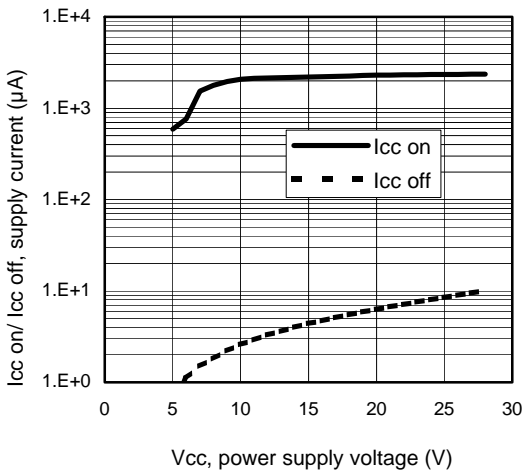

**Figure 11 – Icc on/ Icc off (µA) Vs Vcc (V)**

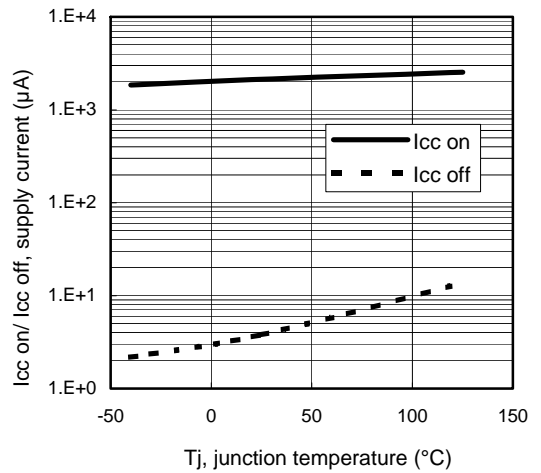

**Figure 12 – Icc on/ Icc off (µA) Vs Tj (°C)**



## Case Outline - TO220 (5 lead) - Automotive Q100 PbF qualified

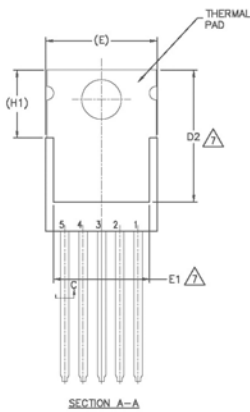
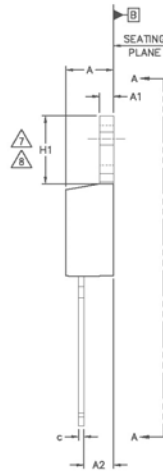
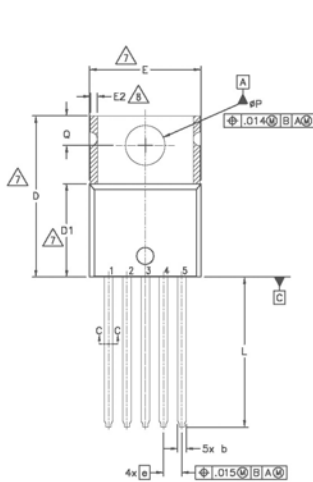

| DIMENSION | DIMENSIONS  |       |          |      | NOTES |
|-----------|-------------|-------|----------|------|-------|
|           | MILLIMETERS |       | INCHES   |      |       |
|           | MIN.        | MAX.  | MIN.     | MAX. |       |
| A         | 3.56        | 4.83  | .140     | .190 | 5     |
| A1        | 0.51        | 1.40  | .020     | .055 |       |
| A2        | 2.03        | 2.92  | .080     | .115 | 5     |
| b         | 0.64        | 0.89  | .025     | .035 |       |
| b1        | 0.64        | 0.84  | .025     | .033 | 4     |
| c         | 0.38        | 0.61  | .014     | .024 |       |
| c1        | 0.38        | 0.56  | .014     | .022 | 7,8   |
| D         | 14.22       | 16.51 | .560     | .650 |       |
| D1        | 8.38        | 9.02  | .330     | .355 | 7     |
| D2        | 11.68       | 12.88 | .460     | .507 |       |
| E         | 9.65        | 10.67 | .380     | .420 | 4,7   |
| E1        | 6.86        | 8.89  | .270     | .350 | 7     |
| E2        | -           | 0.76  | -        | .030 | 8     |
| e         | 1.70 BSC    |       | .067 BSC |      | 7,8   |
| H1        | 5.84        | 6.86  | .230     | .270 |       |
| L         | 12.70       | 14.73 | .500     | .580 |       |
| L1        | 3.53        | 3.73  | .139     | .147 |       |
| ϕP        | 2.54        | 3.05  | .100     | .120 |       |

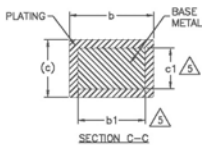

**NOTES:**

- 1.- DIMENSIONING AND TOLERANCING AS PER ASME Y14.5 M- 1994.
- 2.- DIMENSIONS ARE SHOWN IN INCHES [MILLIMETERS].
- 3.- LEAD DIMENSION AND FINISH UNCONTROLLED IN L1.
- 4.- DIMENSION D, D1 & E DO NOT INCLUDE MOLD FLASH. MOLD FLASH SHALL NOT EXCEED .005" (0.127) PER SIDE. THESE DIMENSIONS ARE MEASURED AT THE OUTERMOST EXTREMES OF THE PLASTIC BODY. DIMENSION b1 & c1 APPLY TO BASE METAL ONLY.
- 5.- CONTROLLING DIMENSION : INCHES.
- 7.- THERMAL PAD CONTOUR OPTIONAL WITHIN DIMENSIONS E,H1,D2 & E1
- 8.- DIMENSION E2 X H1 DEFINE A ZONE WHERE STAMPING AND SINGULATION IRREGULARITIES ARE ALLOWED.
- 9.- OUTLINE CONFORMS TO JEDEC TO-220, EXCEPT A2 (max) AND D2 (min.) WHERE DIMENSIONS ARE DERIVED FROM THE ACTUAL PACKAGE OUTLINE.
- 10.- LEADS AND DRAIN ARE PLATED WITH 100X Sn

## Case Outline 5 Lead - D2PAK - Automotive Q100 PbF MSL1 qualified

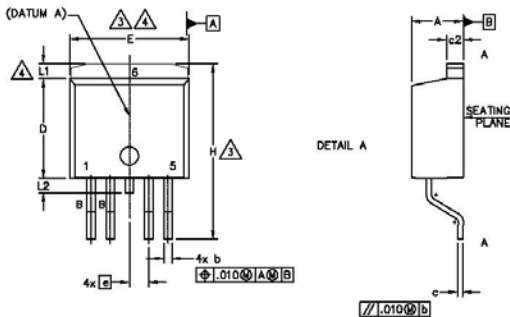
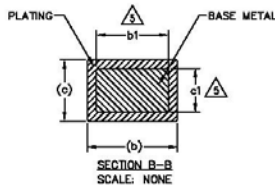
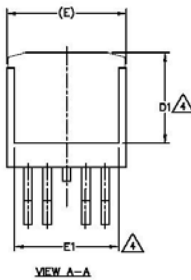
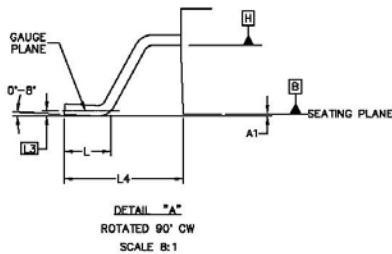

NOTES:

1. DIMENSIONING AND TOLERANCING AS PER ASME Y14.5M-1994
2. DIMENSIONS ARE SHOWN IN MILLIMETERS [INCHES]
3. DIMENSION D & E DO NOT INCLUDE MOLD FLASH. MOLD FLASH SHALL NOT EXCEED 0.127 [.005"] PER SIDE. THESE DIMENSIONS ARE MEASURED AT THE OUTMOST EXTREMES OF THE PLASTIC BODY AT DATUM H.
4. THERMAL PAD CONTOUR OPTIONAL WITHIN DIMENSION E, L1, D1 & E1.
5. DIMENSION b1 AND c1 APPLY TO BASE METAL ONLY.
6. DATUM A & B TO BE DETERMINED AT DATUM PLANE H.
7. CONTROLLING DIMENSION: INCH.
8. OUTLINE CONFORMS TO JEDEC OUTLINE TO-263BA.
9. LEADS AND DRAIN ARE PLATED : 100% Sn

| SYMBOL | DIMENSIONS  |       |          |      | NOTES |
|--------|-------------|-------|----------|------|-------|
|        | MILLIMETERS |       | INCHES   |      |       |
|        | MIN.        | MAX.  | MIN.     | MAX. |       |
| A      | 4.06        | 4.83  | .160     | .190 | 4     |
| A1     | —           | 0.254 | —        | .010 |       |
| b      | 0.51        | 0.99  | .020     | .039 | 4     |
| b1     | 0.51        | 0.89  | .020     | .035 |       |
| c      | 0.38        | 0.74  | .015     | .029 | 4     |
| c1     | 0.38        | 0.58  | .015     | .023 |       |
| c2     | 1.14        | 1.65  | .045     | .065 | 3     |
| D      | 8.38        | 9.65  | .330     | .380 |       |
| D1     | 6.86        | —     | .270     | —    | 3     |
| E      | 9.65        | 10.67 | .380     | .420 |       |
| E1     | 6.22        | —     | .245     | —    |       |
| e      | 1.70 BSC    |       | .067 BSC |      |       |
| H      | 14.61       | 15.88 | .575     | .625 |       |
| L      | 1.78        | 2.79  | .070     | .110 |       |
| L1     | —           | 1.68  | —        | .066 |       |
| L2     | —           | 1.78  | —        | .070 |       |
| L3     | 0.25 BSC    |       | .010 BSC |      |       |
| L4     | 4.78        | 5.28  | .188     | .208 |       |

## Tape & Reel 5 Lead - D2PAK

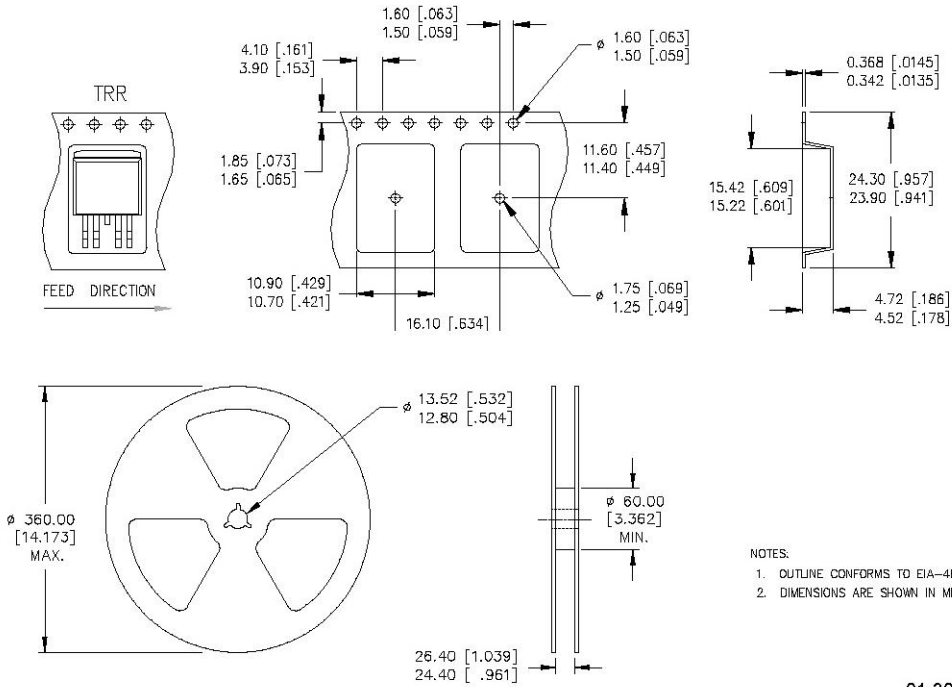

- NOTES:
1. OUTLINE CONFORMS TO EIA-481 & EIA-541.
  2. DIMENSIONS ARE SHOWN IN MILLIMETERS [INCHES].

01-3071 00 / 01-3072 00

## Case Outline 5 Lead – DPAK - Automotive Q100 PbF MSL1 qualified

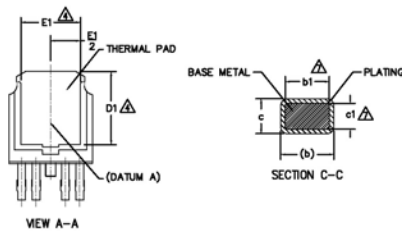
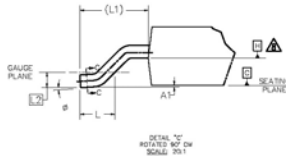

| SYMBOLOL | DIMENSIONS  |       |           |      | NOTES |
|----------|-------------|-------|-----------|------|-------|
|          | MILLIMETERS |       | INCHES    |      |       |
|          | MIN.        | MAX.  | MIN.      | MAX. |       |
| A        | 2.18        | 2.39  | .086      | .094 |       |
| A1       | —           | 0.13  | —         | .005 |       |
| b        | 0.51        | 0.89  | .020      | .035 | 2     |
| b1       | .051        | 0.84  | .020      | .033 | 2     |
| b3       | 4.95        | 5.46  | .195      | .215 |       |
| c        | 0.46        | 0.61  | .018      | .024 |       |
| c1       | 0.41        | 0.56  | .016      | .022 | 2     |
| c2       | 0.46        | 0.89  | .018      | .035 |       |
| D        | 5.97        | 6.22  | .235      | .245 | 3     |
| D1       | 5.21        | —     | .205      | —    |       |
| E        | 6.35        | 6.73  | .250      | .265 | 3     |
| E1       | 4.32        | —     | .170      | —    |       |
| e        | 1.14 BSC    |       | .045 BSC  |      |       |
| H        | 9.40        | 10.41 | .370      | .410 |       |
| L        | 1.40        | 1.78  | .055      | .070 |       |
| L1       | 2.74 BSC    |       | .108 REF. |      |       |
| L2       | 0.51 BSC    |       | .020 BSC  |      |       |
| L3       | 0.89        | 1.27  | .035      | .050 |       |
| L4       | —           | 1.02  | —         | .040 |       |
| L5       | 1.14        | 1.52  | .045      | .060 |       |
| φ        | 0"          | 10"   | 0"        | 10"  |       |
| φ1       | 0"          | 15"   | 0"        | 15"  |       |
| φ2       | 28"         | 32"   | 28"       | 32"  |       |

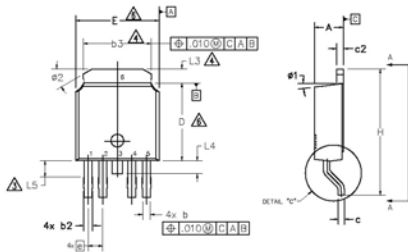

**NOTES:**

- 1.- DIMENSIONING AND TOLERANCING AS PER ASME Y14.5M-1994
- 2.- DIMENSIONS ARE SHOWN IN INCHES [MILLIMETERS].
- 3.- LEAD DIMENSION UNCONTROLLED IN L5.
- 4.- DIMENSION D1, E1, L3 & b3 ESTABLISH A MINIMUM MOUNTING SURFACE FOR THERMAL PAD.
- 5.- SECTION C-C DIMENSIONS APPLY TO THE FLAT SECTION OF THE LEAD BETWEEN .005 AND 0.10 [0.13 AND 0.25] FROM THE LEAD TIP.
- 6.- DIMENSION D & E DO NOT INCLUDE MOLD FLASH. MOLD FLASH SHALL NOT EXCEED .005 [0.13] PER SIDE. THESE DIMENSIONS ARE MEASURED AT THE OUTMOST EXTREMES OF THE PLASTIC BODY.
- 7.- DIMENSION b1 & c1 APPLIED TO BASE METAL ONLY.
- 8.- DATUM A & B TO BE DETERMINED AT DATUM PLANE H.
- 9.- OUTLINE CONFORMS TO JEDEC OUTLINE TO-252.
10. LEADS AND DRAIN ARE PLATED WITH 100% Sn

**Tape & Reel 5 Lead – DPAK**

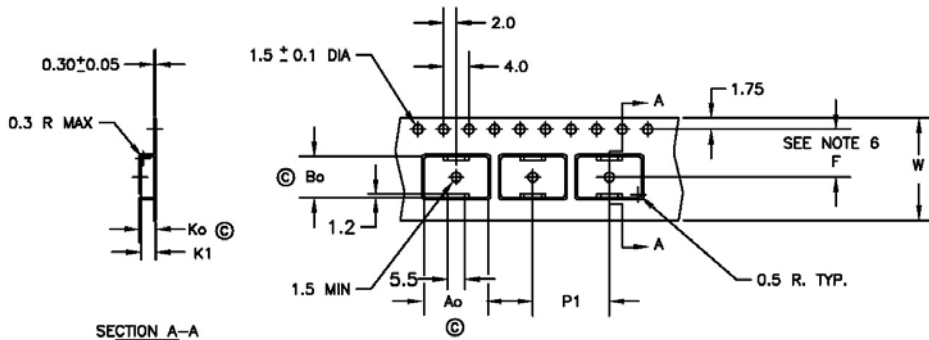

- Ao = 10.5 mm
- Bo = 7.0 mm
- Ko = 2.8 mm
- K1 = 2.4 mm
- F = 7.5 mm
- P1 = 12.0 mm
- W = 16.0 ± .3 mm

**NOTES:**

1. 10 SPROCKET HOLE PUNCH CUMULATIVE TOLERANCE ±.02
2. CAMBER NOT TO EXCEED 1mm IN 100mm
3. MATERIAL: CONDUCTIVE BLACK POLYSTYRENE
4. Ao AND Bo MEASURED ON A PLANE 0.3mm ABOVE THE BOTTOM OF THE POCKET
5. Ko MEASURED FROM A PLANE ON THE INSIDE BOTTOM OF THE POCKET TO THE TOP SURFACE OF THE CARRIER
6. POCKET POSITION RELATIVE TO THE SPROCKET HOLE MEASURED AS TRUE POSITION OF POCKET, NOT POCKET HOLE
7. VENDOR: (OPTIONAL)
8. MUST ALSO MEET REQUIREMENTS OF EIA STANDARD #EIA-481A, TAPING OF SURFACE-MOUNT COMPONENTS FOR AUTOMATIC PLACEMENT.
9. TOLERANCE TO BE MANUFACTURER STANDARD
10. SURFACE RESISTIVITY OF MOLDED MATL: MUST MEASURE LESS THAN OR EQUAL TO 10<sup>8</sup> OHMS PER SQUARE. MEASURED IN ACCORDANCE TO PROCEDURE GIVEN IN ASTM D-257 & ASTM D-991 (REF. C-9000 SPEC.)
11. TOTAL LENGTH PER REEL MUST BE 79 METERS
12. © CRITICAL DIMENSION

## X-ON Electronics

Largest Supplier of Electrical and Electronic Components

*Click to view similar products for [Gate Drivers](#) category:*

*Click to view products by [Infineon](#) manufacturer:*

Other Similar products are found below :

[00028](#) [00053P0231](#) [8967380000](#) [56956](#) [CR7E-30DB-3.96E\(72\)](#) [57.404.7355.5](#) [LT4936](#) [57.904.0755.0](#) [5801-0903](#) [5803-0901](#) [5811-0902](#)  
[5813-0901](#) [58410](#) [00576P0030](#) [00581P0070](#) [5882900001](#) [00103P0020](#) [00600P0005](#) [00-9050-LRPP](#) [00-9090-RDPP](#) [5951900000](#) [01-](#)  
[1003W-10/32-15](#) [LTI LA6E-1S-WH-RC-FN12VXCR1](#) [0131700000](#) [00-2240](#) [LTP70N06](#) [LVP640](#) [0158-624-00](#) [5J0-1000LG-SIL](#) [020017-13](#)  
[LY1D-2-5S-AC120](#) [LY2-0-US-AC120](#) [LY2-US-AC240](#) [LY3-UA-DC24](#) [00-5150](#) [00576P0020](#) [00600P0010](#) [LZNQ2M-US-DC5](#) [LZNQ2-](#)  
[US-DC12](#) [LZP40N10](#) [00-8196-RDPP](#) [00-8274-RDPP](#) [00-8275-RDNP](#) [00-8609-RDPP](#) [00-8722-RDPP](#) [00-8728-WHPP](#) [00-8869-RDPP](#) [00-](#)  
[9051-RDPP](#) [00-9091-LRPP](#) [00-9291-RDPP](#)