



SPECIFICATION FOR APPROVAL

Customer : STD

Description : DC FAN

Customer Part No. _____

REV. : _____

Delta Model No. : THD1348HE

REV. : 00

Sample Issue No. : _____

Sample Issue Date : Mar.20.2017

PLEASE SEND ONE COPY OF THIS SPECIFICATION BACK AFTER YOU SIGNED APPROVAL FOR PRODUCTION PRE-ARRANGMENT.

APPROVED BY:

DATE :

DELTA ELECTRONICS, INC.

TAOYUAN PLANT

252, SHANG YING ROAD, KUEI SAN INDUSTRIAL ZONE

TAOYUAN SHIEN, TAIWAN, R.O.C.

TEL:886-(0)3-3591968

FAX:886-(0)3-3591991

Delta Electronics, Inc.
No.252, Shanying Rd., Guishan Dist.,
Taoyuan City 333, Taiwan (R.O.C.)

TEL : 886-(0)3-3591968
FAX : 886-(0)3-3591991

STATEMENT OF DEVIATION

NONE

DESCRIPTION:

Delta Electronics, Inc.
No.252, Shanying Rd., Guishan Dist.,
Taoyuan City 333, Taiwan (R.O.C.)

TEL : 886-(0)3-3591968
FAX : 886-(0)3-3591991

Specification For Approval

Customer : STD

Description : DC FAN

Customer P/N :

rev. :

Delta model no. : THD1348HE

Delta Safety Model No.: THD1348HE

Sample revision. : 00

Issue no.:

Sample issue date : MAR.20 2017

Quantity :

1. SCOPE:

THIS SPECIFICATION DEFINES THE ELECTRICAL AND MECHANICAL CHARACTERISTICS OF THE DC BRUSHLESS AXIAL FLOW FAN.

2. CHARACTERS:

ITEM	DESCRIPTION
RATED VOLTAGE	48.0 VDC
OPERATION VOLTAGE	36.0 - 60.0 VDC
INPUT CURRENT (AVG.) (AT ZERO STATIC PRESSURE)	5.00 (MAX. 6.00) A (SAFETY CURRENT ON LABEL : 9.00A)
INPUT POWER (AVG.) (AT ZERO STATIC PRESSURE)	240.0 (MAX.288.0 W)
SPEED	12500 ±10% R.P.M.
MAX. AIR FLOW (AT ZERO STATIC PRESSURE)	13.87 (MIN. 12.48) M ³ /MIN. 490.00 (MIN. 441.00) CFM
MAX. AIR PRESSURE (AT ZERO AIRFLOW)	180.34 (MIN. 144.27) mmH ₂ O 7.10 (MIN. 5.68) inchH ₂ O
ACOUSTICAL NOISE (AVG.)	82.0 (MAX. 86.0) dB-A
INSULATION TYPE	UL: CLASS A
INSULATION STRENGT	10 MEG OHM MIN. AT 500 VDC (BETWEEN FRAME AND LEAD WIRES.)
DIELECTRIC STRENGTH	5 mA MAX. AT 500 VAC 50/60 Hz ONE MINUTE, (BETWEEN FRAME AND LEAD WIRES.(USUALLY INSPECT AT 600V AC,3SEC. 5mA))

(continued)

PAGE 1

PART NO:

DELTA MODEL: THD1348HE

LIFE EXPECTANCE(L10) (AT LABEL VOLTAGE)	70,000 HOURS CONTINUOUS OPERATION AT 40 ° C WITH 15 ~ 65 %RH.
LIFE EXPECTANCE AT IPC9591(L10) (AT LABEL VOLTAGE)	16,000 HOURS CONTINUOUS OPERATION AT 40 ° C WITH 15 ~ 65 %RH.
ROTATION	COUNTERCLOCKWISE VIEW FROM INLET SIDE
LOCKED CURRENT PROTECTION	THE CURRENT WILL SHUT DOWN WHEN ROTOR LOCKED AND FIXED.
EXTERNAL COVER	OPEN TYPE

NOTES:

1. ALL READINGS ARE MEASURED AFTER STABLY WARMING UP THROUGH 10 MINUTES.
2. STANDARD AIR PROPERTY IS AIR AT (Td) 25°C TEMPER ATURE, (RH) 65% RELATIVE HUMIDITY , AND (Pb) 760 mmHg BAROMETRIC PRESSURE.
3. THE CHARACTERS SHOWED IN PAGE 1 IS THE CONDITION OF BOTH FANS RUN.
4. ACOUSTICAL NOISE MEASURING CONDITION:

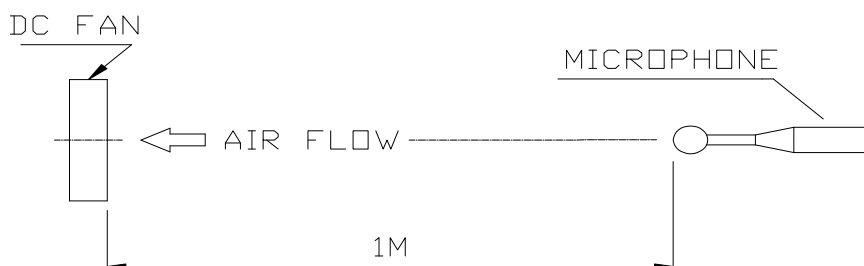

DOISE IS MEASURED AT RATED VOLTAGE IN FREE AIR IN ANECHOIC CHAMBER WITH B & K SOUND LEVEL METER WITH MICROPHONE AT A DISTANCE OF ONE METER FROM THE FAN INTAKE.

PART NO:

DELTA MODEL: THD1348HE

3. MECHANICAL:

- 3-1. DIMENSIONS----- SEE DIMENSIONS DRAWING
- 3-2. FRAME-----AL
- 3-3. IMPELLER----- PLASTIC UL: 94V-0
- 3-4. BEARING SYSTEM-----TWO BALL BEARINGS
- 3-5. WEIGHT-----720 GRAMS(REF.)
- 3-5-1. IMPELLER WEIGHT-----240 GRAMS(REF.)

4. ENVIRONMENTAL:

- 4-1. OPERATING TEMPERATURE----- -10 TO +70 DEGREE C
- 4-2. STORAGE TEMPERATURE----- -40 TO +75 DEGREE C
- 4-3. OPERATING HUMIDITY----- 5 TO 90 % RH
- 4-4. STORAGE HUMIDITY----- 5 TO 95 % RH

5. PROTECTION:

- 5-1. LOCKED ROTOR PROTECTION
IMPEDANCE OF MOTOR WINDING PROTECTS MOTOR FROM FIRE IN
96 HOURS OF LOCKED ROTOR CONDITION AT THE RATED VOLTAGE.
- 5-2. POLARITY PROTECTION
BE CAPABLE OF WITHSTANDING IF REVERSE CONNECTION FOR
POSITIVE AND NEGATIVE LEADS.

6. RE OZONE DEPLETING SUBSTANCES:

- 6-1. NO CONTAINING PBBs, PBBOs, CFCs, PBBEs, PBDPEs AND HCFCs.

7. PRODUCTION LOCATION

- 7-1. PRODUCTS WILL BE PRODUCED IN CHINA OR THAILAND.

PART NO:

DELTA MODEL: THD1348HE

8. P & Q CURVE :

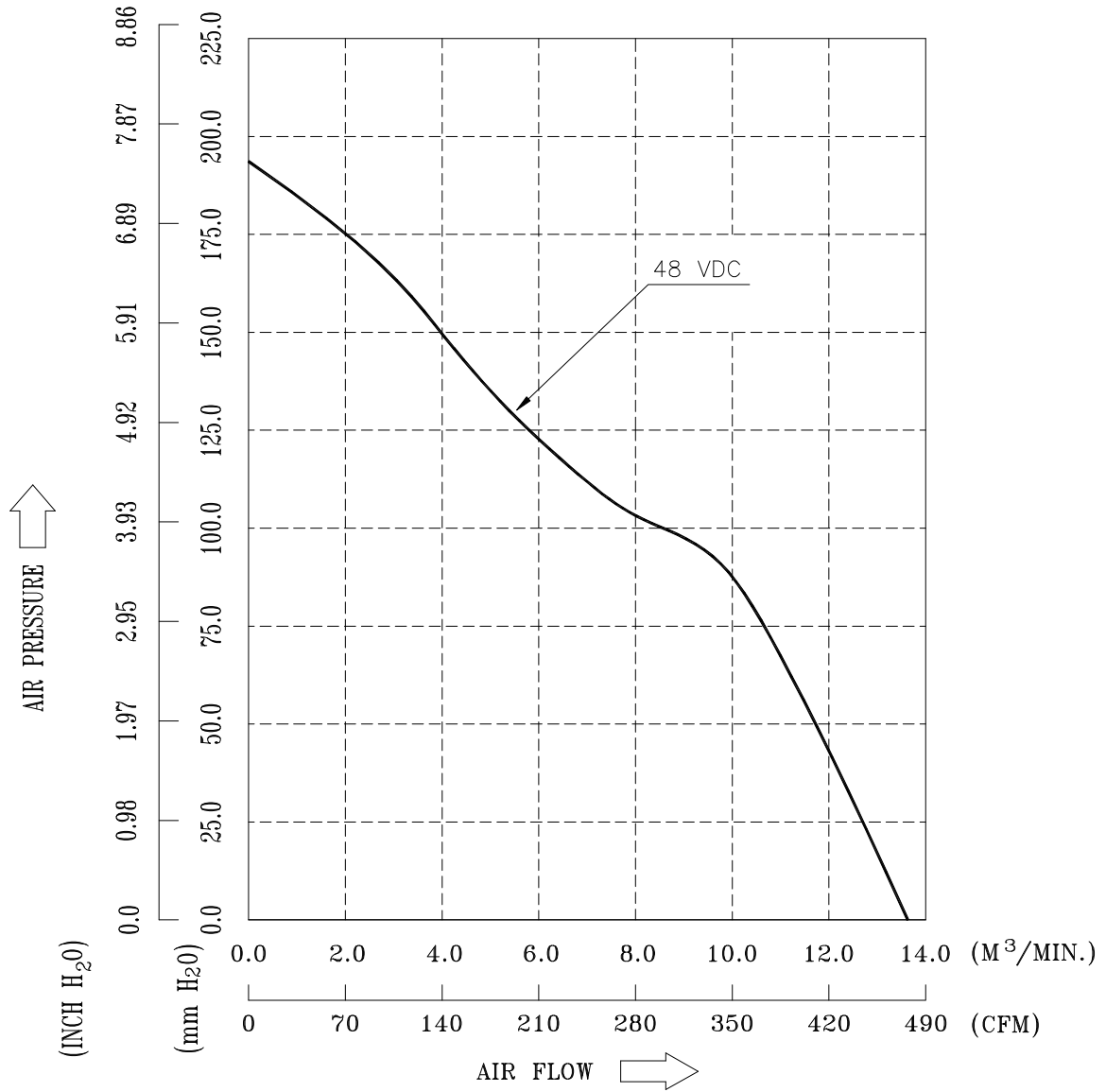

* TEST CONDITION: INPUT VOLTAGE ----- OPERATION VOLTAGE
TEMPERATURE ----- ROOM TEMPERATURE
HUMIDITY ----- 65%RH

PART NO:

DELTA MODEL: THD1348HE

9. DIMENSION DRAWING:

LABEL:

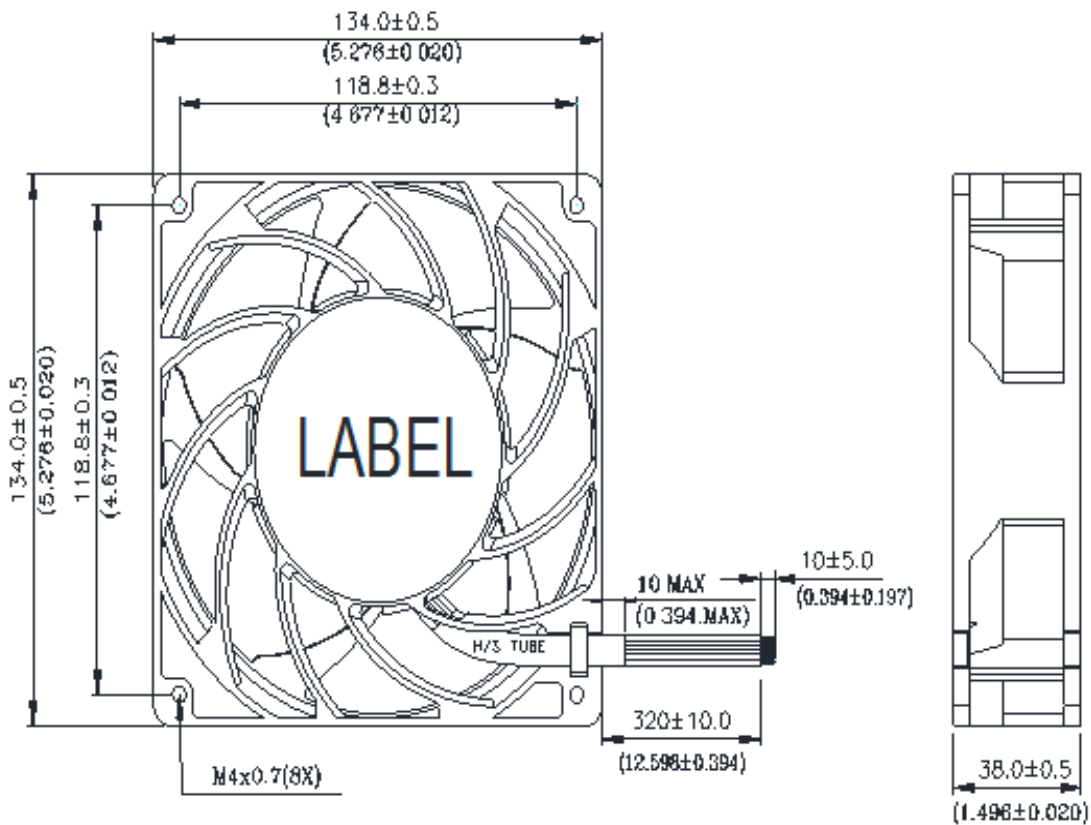
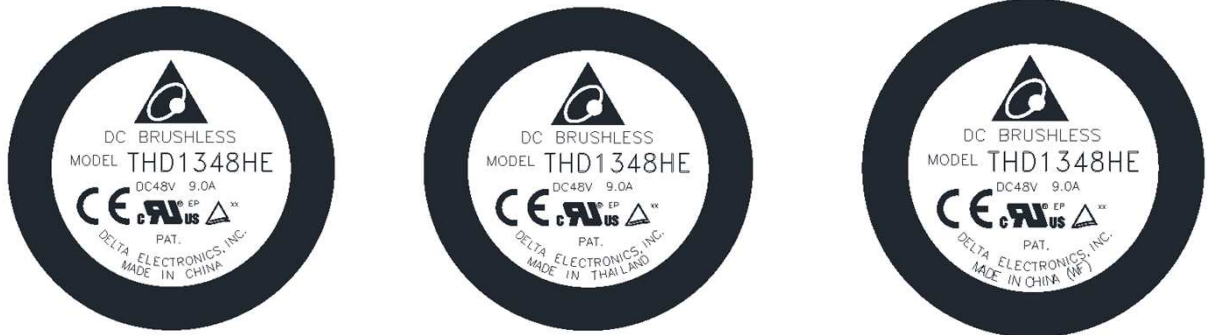

NOTES:

- 1.LEAD WIRE: UL1430 AWG#24
RED WIRE---(+)
YELLOW WIRE-----(PWM)
BLACK WIRE---(-)
BLUE WIRE---(FOO)
- 2.THIS PRODUCT IS RoHS COMPLIANT

PART NO:

DELTA MODEL: THD1348HE

10. MOUNTING PANEL CUTOUT

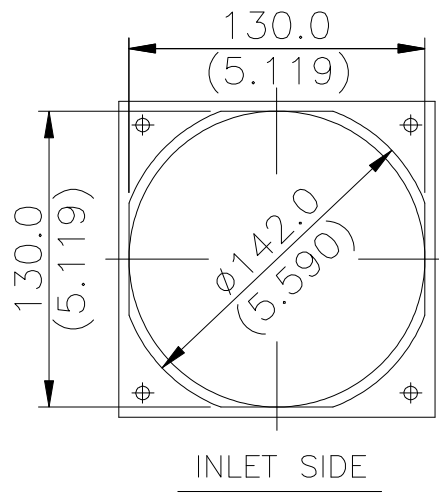
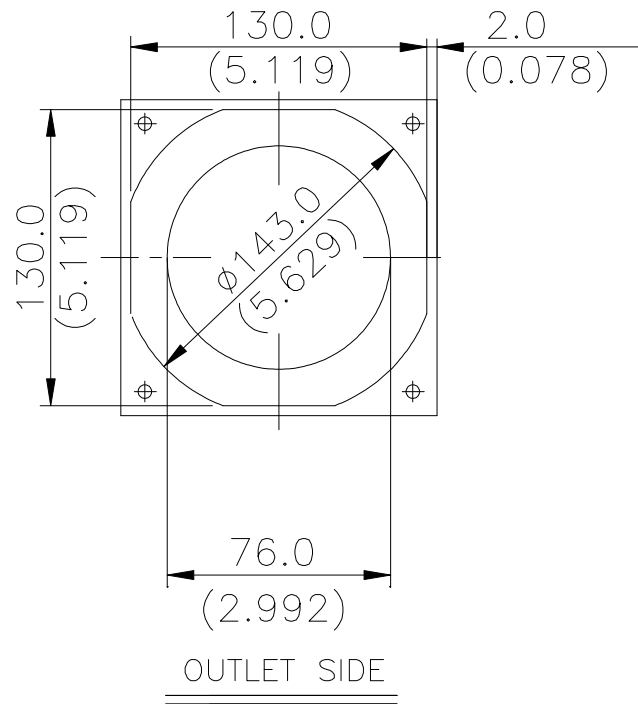

PART NO:

DELTA MODEL: THD1348HE

11.FREQUENCY GENERATOR (FG) SIGNAL:

1. OUTPUT CIRCUIT - OPEN COLLECTOR MODE:

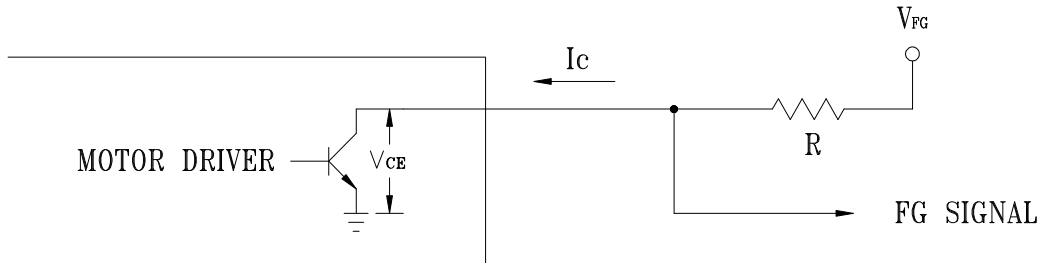

CAUTION:

THE LEAD WIRE OF FG SIGNAL CAN NOT TOUCH THE LEAD WIRE OF POSITIVE OR NEGATIVE.

2. SPECIFICATION:

$$V_{FG} = 60.0V \text{ MAX.}$$

$$I_c = 10mA \text{ MAX.}$$

$$V_{CE(sat)} = 0.5V \text{ MAX.}$$

$$R \geq V_{FG} / I_c$$

3. FREQUENCY GENERATOR WAVEFORM:

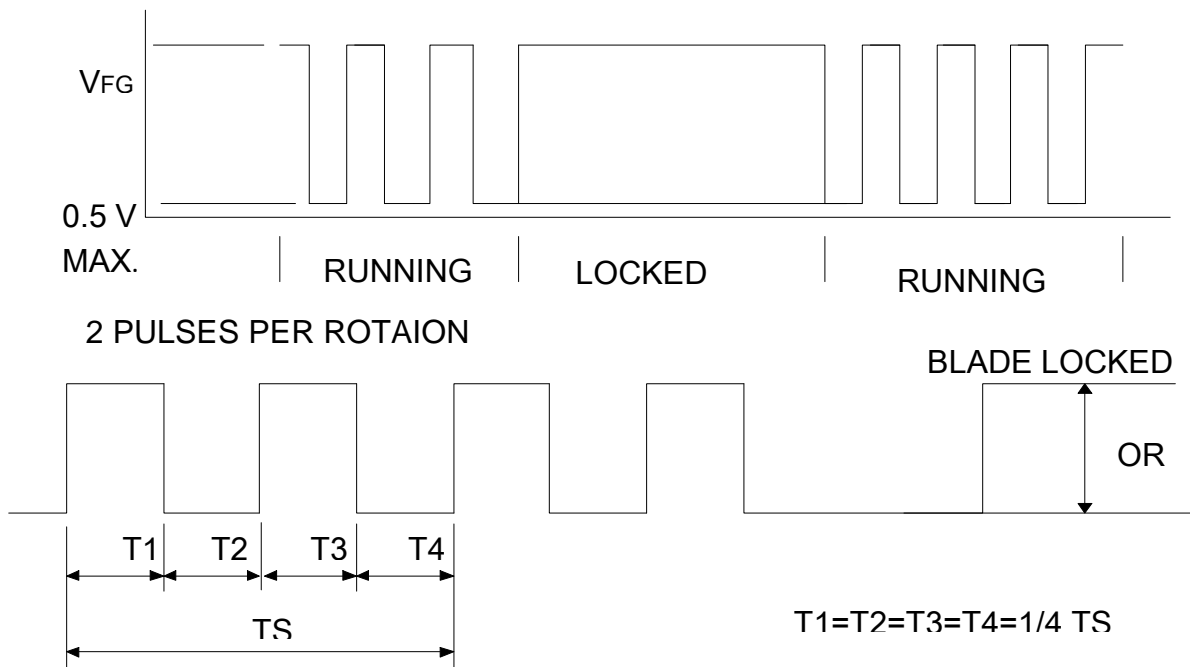

$$N = \text{R.P.M}$$

$$T_S = 60/N(\text{SEC})$$

*VOLTAGE LEVEL AFTER BLADE LOCKED

PART NO:

DELTA MODEL: THD1348HE

12. PWM CONTROL SIGNAL: (AT RATED VOLTAGE 48VDC ; 25 DEGREE C)
SIGNAL VOLTAGE RANGE: -0.8~20 VDC

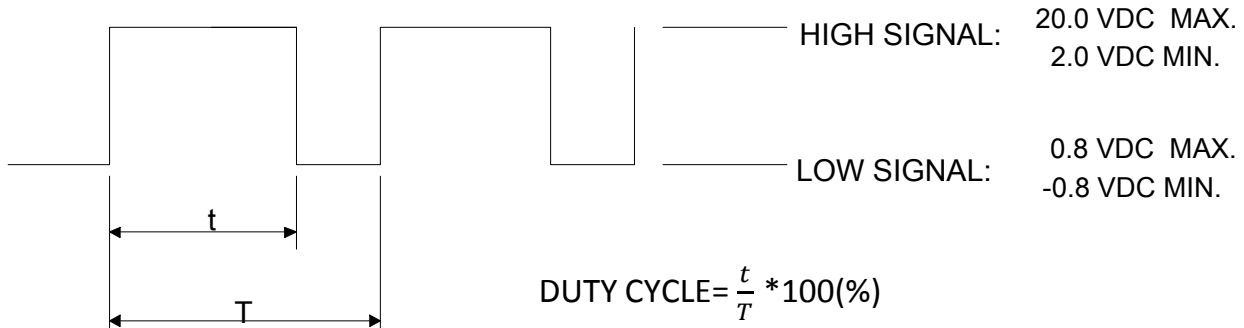

*THE FREQUENCY FOR CONTROL SIGNAL OF THE FAN SHALL BE ABLE TO ACCEPT A 1KHZ~30KHZ.

*THE PREFERRED OPERATING POINT FOR THE FAN IS 25K HZ.

*AT 100% DUTY CYCLE, THE ROTOR WILL SPIN AT MAXIMUM SPEED.

*AT 0~20% DUTY CYCLE, THE ROTOR WILL SPIN AT MINIMUM SPEED.

*WITH CONTROL SIGNAL LEAD DISCONNECTED, THE FAN WILL SPIN AT MAXIMUM SPEED.

*AT 48VDC 25KHZ 30% DUTY CYCLE , THE FAN WILL BE ABLE TO START FROM A DEAD STOP

13. SPEED VS PWM CONTROL SIGNAL: (AT RATED VOLTAGE 48V ; 25 DEGREE C ; PWM SIGNAL WITH 5 VDC TTL OR CMOS LEVELS & 25 KHZ)

DUTY CYCLE (%)	SPEED R.P.M. (REF.)	CURRENT (A) TYP.
		TOTAL
100	12500±10%	5.00A
50	6100±10%	0.85A
0~20	2450±10%	0.20A

14. PWM CONTROL LEAD WIRE INPUT IMPEDANCE:

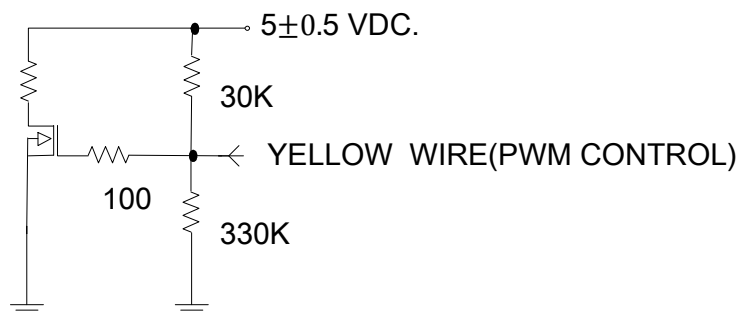

Fan Characteristics Informations for Reference

1. PQ of Duty

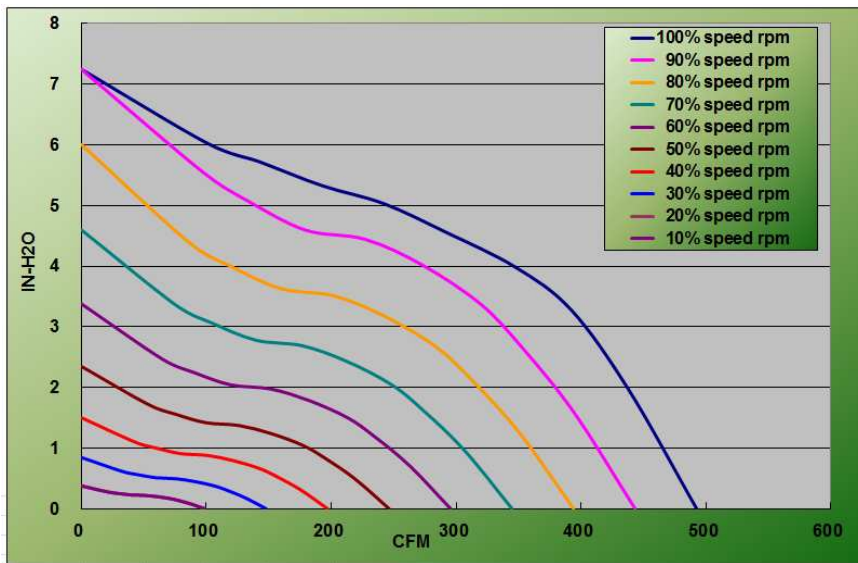

2. Duty vs Speed Curve

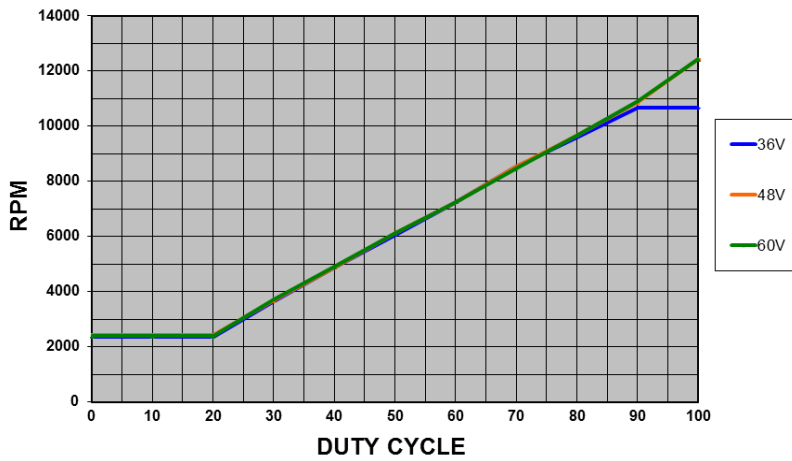

Fan Characteristics Informations for Reference

3. PQ vs Watt of Voltage

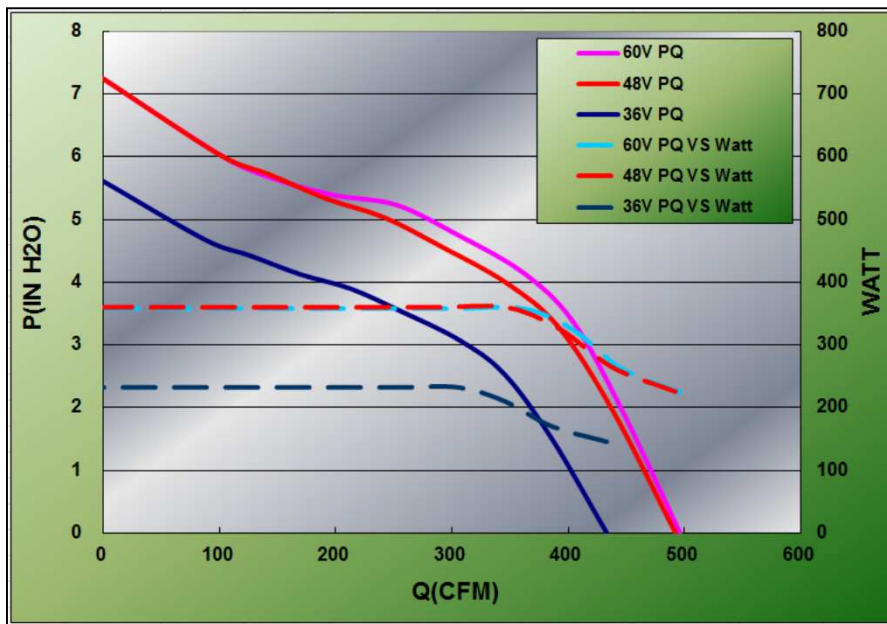

4. Duty vs Speed and Current Table

占空比	額定工作電壓 (48V)		下限工作電壓 (36V)		上限工作電壓 (60V)	
	轉速(r.p.m)	電流 (A)	轉速(r.p.m)	電流 (A)	轉速(r.p.m)	電流 (A)
0%	2442	0.19	2364	0.17	2394	0.13
10%	2418	0.19	2364	0.93	2394	0.13
20%	2442	0.19	2364	4.01	2394	0.13
30%	3678	0.31	3666	0.33	3732	0.25
40%	4884	0.50	4872	0.58	4902	0.39
50%	6120	0.85	6060	0.93	6120	0.64
60%	7260	1.28	7260	1.46	7260	0.95
70%	8520	1.80	8520	2.13	8460	1.38
80%	9660	2.47	9600	3.01	9660	1.95
90%	10860	3.40	10680	4.01	10920	2.71
100%	12420	4.96	10680	4.01	12420	3.93

The current and r.p.m value of 10% tolerance.

Fan Characteristics Informations for Reference

5. FRAME TYPE OF SCREW TORQUE

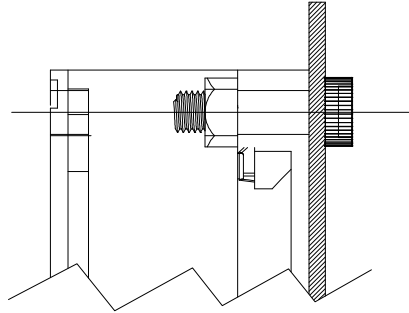

MOUNTING DRAWING

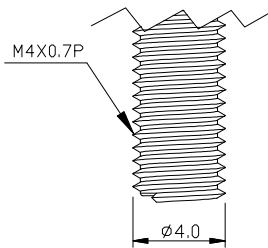

MECHANICAL SCREW

MOUNTING HOLE DIAMETER	SCREW TYPE	SCREW SPEC.	RECOMMENDED MAX. TORQUE(kgf-cm)
M4	MECHANICAL	M4x0.7	10.0±10%

NOTE:

1. FLANGE TYPE.
2. MECHANICAL SCREW ACCORDING TO JIS B 0205.



Application Notice

- 1. Delta will not guarantee the performance of the products if the application condition falls outside the parameters set forth in the specification.**
- 2. A written request should be submitted to Delta prior to approval if deviation from this specification is required.**
- 3. Please exercise caution when handling fans. Damage may be caused when pressure is applied to the impeller, if the fans are handled by the lead wires, or if the fan was hard-dropped to the production floor.**
- 4. Except as pertains to some special designs, there is no guarantee that the products will be free from any such safety problems or failures as caused by the introduction of powder, droplets of water or encroachment of insect into the hub.**
- 5. The above-mentioned conditions are representative of some unique examples and viewed as the first point of reference prior to all other information.**
- 6. It is very important to establish the correct polarity before connecting the fan to the power source. Positive (+) and Negative (-). Damage may be caused to the fans if connection is with reverse polarity, if there is no foolproof method to protect against such error specifically mentioned in this spec.**
- 7. Delta fans without special protection are not suitable where any corrosive fluids are introduced to their environment.**
- 8. Please ensure all fans are stored according to the storage temperature limits specified. Do not store fans in a high humidity environment. We highly recommend performance testing is conducted before shipping, if the fans have been stored over 6 months.**
- 9. Not all fans are provided with the Lock Rotor Protection feature. If you impair the rotation of the impeller for the fans that do not have this function, the performance of those fans will lead to failure.**
- 10. Please be cautious when mounting the fan. Incorrect mounting of fans may cause excess resonance, vibration and subsequent noise.**
- 11. It is important to consider safety when testing the fans. A suitable fan guard should be fitted to the fan to guard against any potential for personal injury.**
- 12. Except where specifically stated, all tests are carried out at room (ambient) temperature and relative humidity conditions of 25°C, 65% RH. The test value is only for fan performance itself.**
- 13. Be certain to connect an “ 4.7μF or greater” capacitor to the fan externally when the application calls for using multiple fans in parallel, to avoid any unstable power.**

X-ON Electronics

Largest Supplier of Electrical and Electronic Components

Click to view similar products for [DC Fans](#) category:

Click to view products by [Delta](#) manufacturer:

Other Similar products are found below :

[614R](#) [6424/2HP-210](#) [8312R](#) [DV4118/2NP-183](#) [AFB0948HH-S687](#) [PFB0824DHE-8B72](#) [G2E085-AA05-10](#) [RD20S-4/210660](#) [4318/12T](#)
[4418HH](#) [AUB0912H-F00](#) [3412N/2ME](#) [K2E225-RA92-09](#) [4184N/2XR](#) [5214N2HH](#) [614J2HHPR-010](#) [8412NGL-12](#) [4114N/12HHR-297](#)
[4656](#) [ZWR-903](#) [4112N12GL-175](#) [KD2406PKB2.\(2\).GN](#) [AFB1248HHE](#) [AFB1212LE-F00](#) [FAN-SCH-1](#) [MF60151V1-1000U-G99](#)
[PF80252V1-1000U-G99](#) [PF92252V1-1000U-G99](#) [4112N/2H6P](#) [4114N/17-251](#) [6212NH](#) [622/2N](#) [712F-011](#) [8218J/2NP-181](#) [W1G180-AB47-](#)
[15](#) [FAA1-12038NBKW31-A](#) [6318N/2TDP](#) [6318N/2H3PU](#) [6318HU](#) [424JMU](#) [PMD1206PTVX-A.U.GN](#) [PF80251B2-000U-F99](#)
[EF40101BX-1000U-G99](#) [AD1224LB-A71GL](#) [9GA0924L4021](#) [9GA0924M4021](#) [9GA0924M4011](#) [9GA0824B20011](#) [9GA0812A2D0011](#)
[9GA0912M4D011](#) [9GA0924W4D01](#)