



MODEL NO: 17-215SURC/S530-A2/TR8

Device Number : DSE-175-014 REV. 1.0

0.8mm Height Flat Top LEDs

ECN : _____ Page: 1/8

■ **Features :**

- Package in 8mm tape on 7" diameter reel .
- Compatible with automatic placement equipment.
- Compatible with infrared and vapor phase reflow solder process.
- Mono-color type.

■ **Description :**

- The 17-215 SMD Taping is much smaller than leaded components, thus enable smaller board size, higher packing density, reduced storage space and finally smaller equipment to be obtained.
- Besides, light Weight makes them ideal for miniature application, etc.

■ **Applications :**

- Automotive: backlighting in dashboard and switch.
- Telecommunication: indicator and backlighting in telephone and fax.
- Flat backlight for LCD, switch and symbol.
- General use.

■ **Package Dimension :**

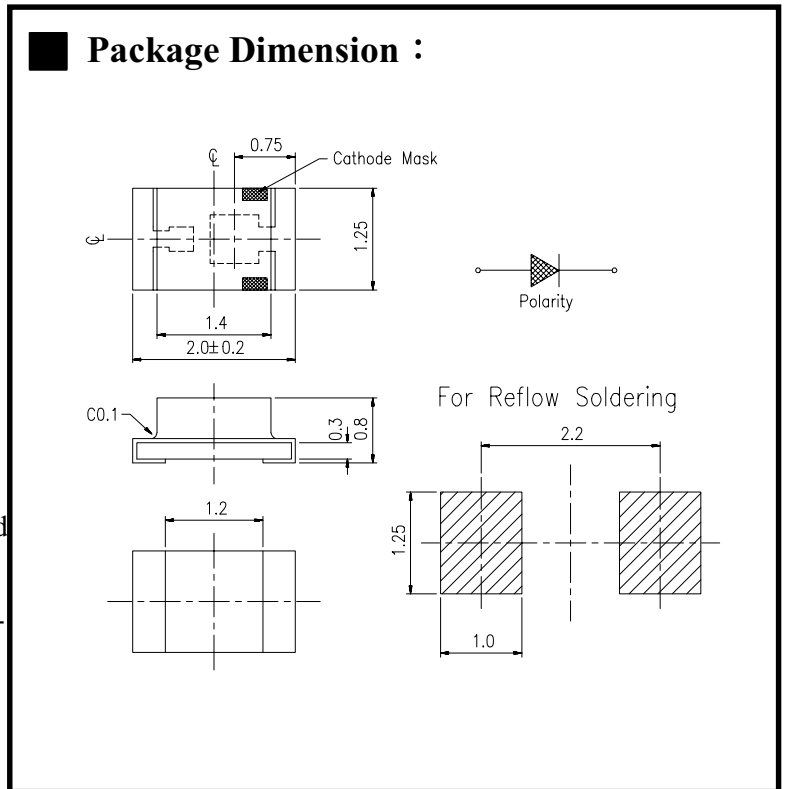

■ **Notes :**

Tolerances Unless Dimension ±
0.1mm
Angle± 0.5°

PART NO	CHIP		Lens Color
	Material	Emitted Color	
17-21SURC/S530-A2/TR8	AlGaInP	Hyper Red	Water Clear

Office: NO. 25, Lane 76, Sec.3, Chung Yang Rd., Tucheng 236, Taipei, Taiwan, R.O.C.

TEL: 886-2-2267-2000, 2267-9936

FAX: 886-2-2267-6244, 2267-6189, 2267-6306

<http://www.everlight.com>



MODEL NO: 17-215SURC/S530-A2/TR8

Device Number : DSE-175-014 REV. 1.0

0.8mm Height Flat Top LEDs

ECN : _____ Page: 2/8

■ **Package Dimension :**

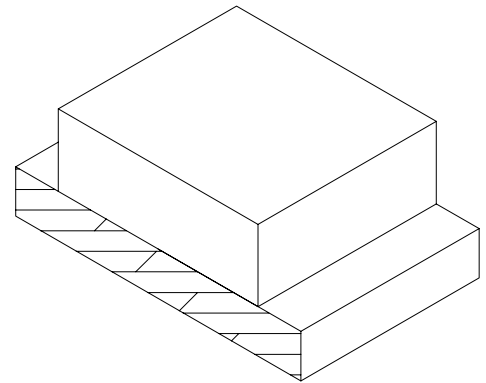
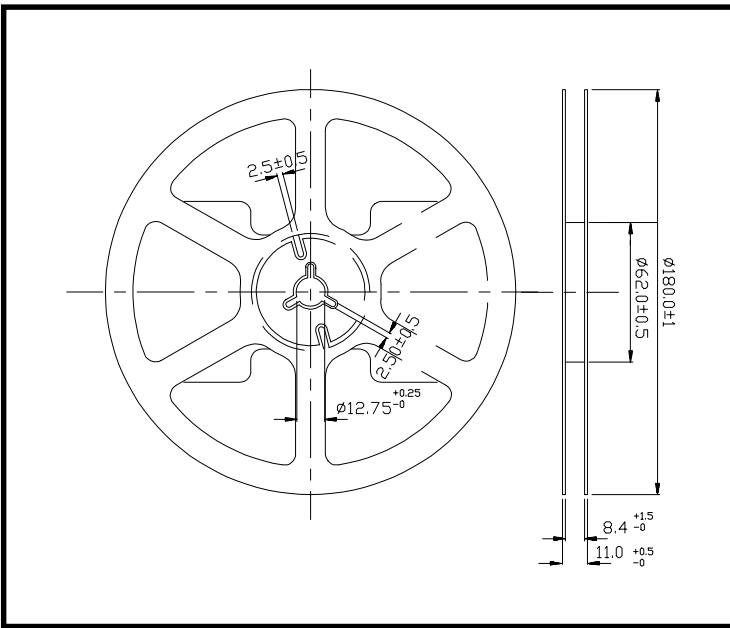

■ **Loaded quantity per reel 3000 pcs/reel :**

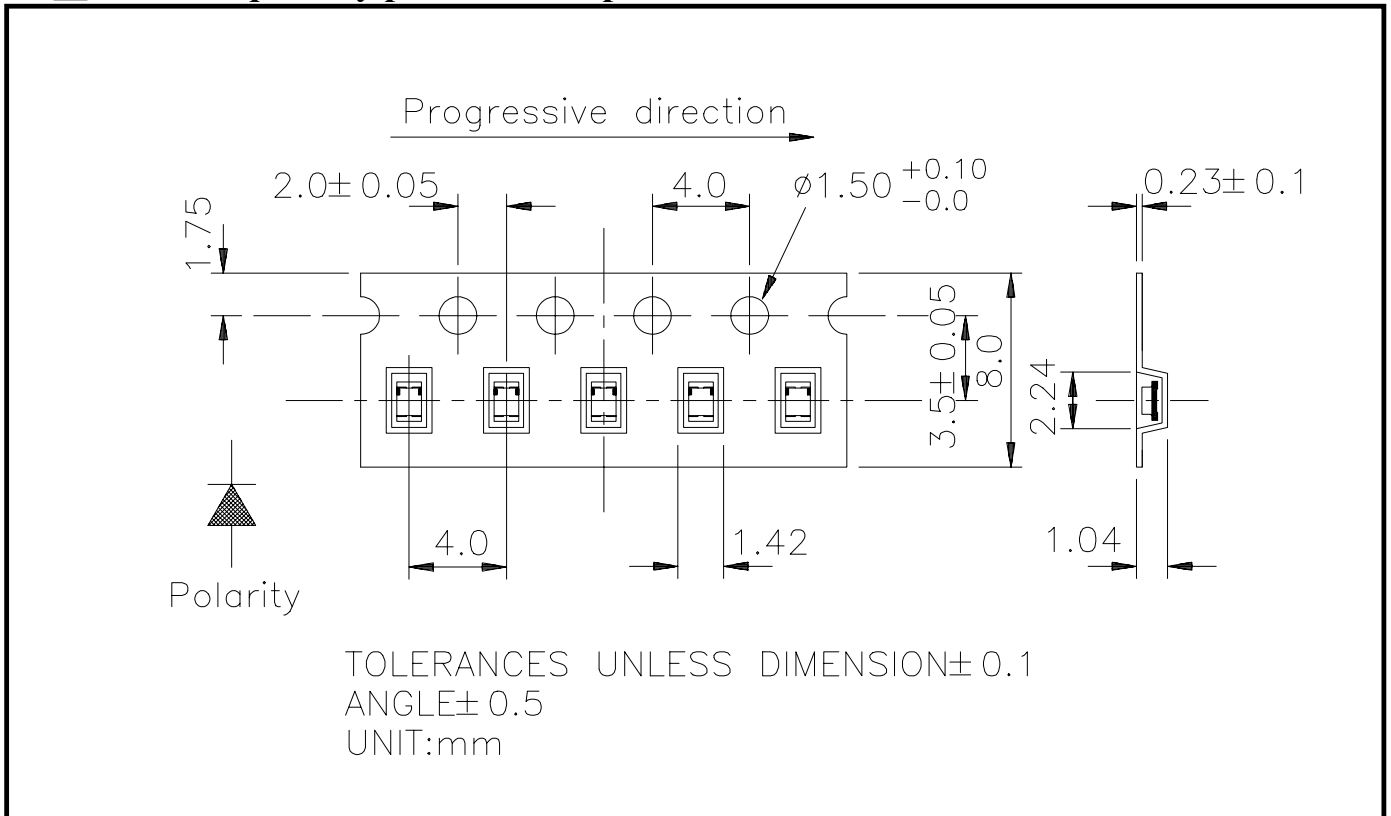



MODEL NO: 17-215SURC/S530-A2/TR8

Device Number : DSE-175-014 REV. 1.0

0.8mm Height Flat Top LEDs

ECN : Page: 3/8

■ **Absolute Maximum Ratings at Ta = 25°C**

Parameter	Symbol	Rating	Unit
Reverse Voltage	Vr	5	V
Forward Current	If	25	mA
Operating Temperature	Topr	-40 ~ +85	°C
Storage Temperature	Tstg	-40 ~ +90	°C
Soldering Temperature	Tsol	260 (for 5 second)	°C
Power Dissipation	Pd	60	mW
Peak Forward Current(Duty 1/10 @ 1KHZ)	If(Peak)	160	mA

■ **Electronic Optical Characteristics :**

Parameter	Symbol	Min.	Typ.	Max.	Unit	Condition
Luminous intensity	Iv	13	32	-----	mcd	If=20mA
Viewing Angle	2θ 1/2	-----	130	-----	deg	If=20mA
Peak Wavelength	λ p	-----	632	-----	nm	If=20mA
Dominant Wavelength	λ d	-----	624	-----	nm	If=20mA
Spectrum Radiation Bandwidth	Δ λ	-----	20	-----	nm	If=20mA
Forward Voltage	Vf	-----	2.0	2.4	V	If=20mA
Reverse Current	Ir	-----	-----	10	μ A	Vr=5V



MODEL NO: 17-215SURC/S530-A2/TR8

Device Number : DSE-175-014 REV. 1.0

0.8mm Height Flat Top LEDs

ECN : _____ Page: 4/8

■ Reliability Test Item And Condition

NO	Item	Test Conditions	Test Hours/Cycle	Sample Size	Ac/Re
1	Solder Heat	TEMP : 260°C ± 5 °C	5 SEC	76 Pcs	0/1
2	Temperature Cycle	H : +85°C 30min ∩ 5 min L : -55°C 30min	50 CYCLE	76 Pcs	0/1
3	Thermal Shock	H : +100°C 5min ∩ 10 sec L : -10°C 5min	50 CYCLE	76 Pcs	0/1
4	High Temperature Storage	TEMP : 100°C	1000 HRS	76 Pcs	0/1
5	Low Temperature Storage	TEMP : -55°C	1000 HRS	76 Pcs	0/1
6	DC Operating Life	If = 20 mA	1000 HRS	76 Pcs	0/1
7	High Temperature / High Humidity	85°C/85% RH	1000 HRS	76 Pcs	0/1



MODEL NO: 17-215SURC/S530-A2/TR8

Device Number : DSE-175-014 REV. 1.0

0.8mm Height Flat Top LEDs

ECN : Page: 5/8

Typical Electro-Optical Characteristic Curves

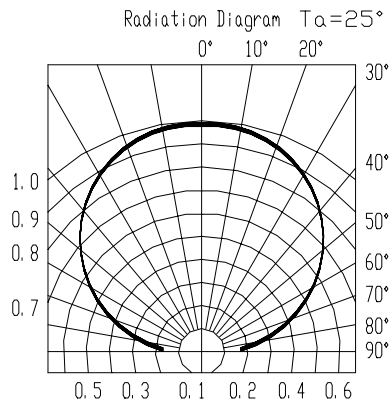
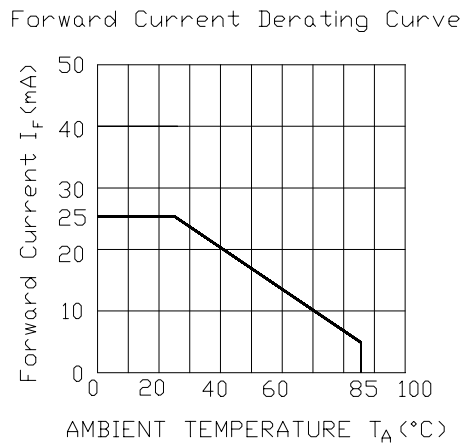
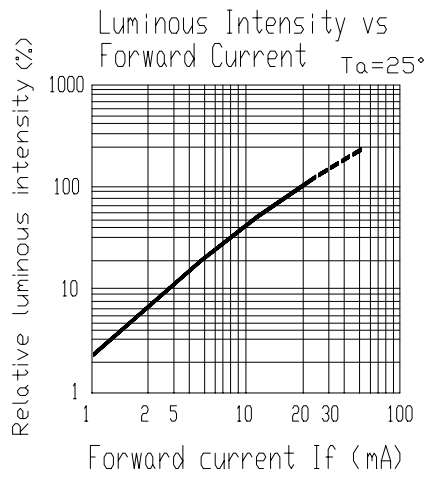
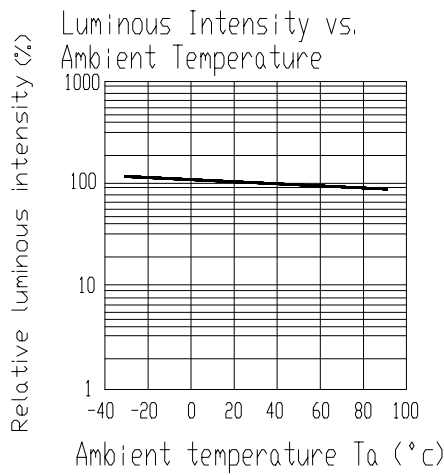
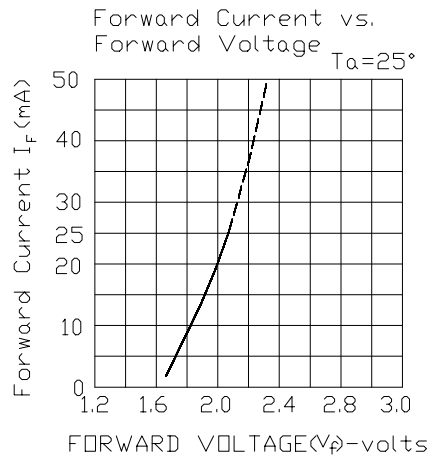
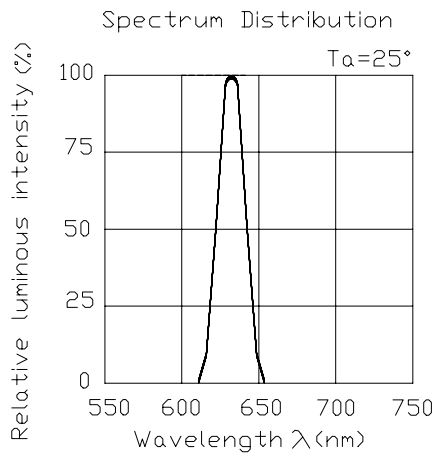



MODEL NO: 17-215SURC/S530-A2/TR8

Device Number : DSE-175-014 REV. 1.0

0.8mm Height Flat Top LEDs

ECN : Page: 6/8

■ Test Circuit

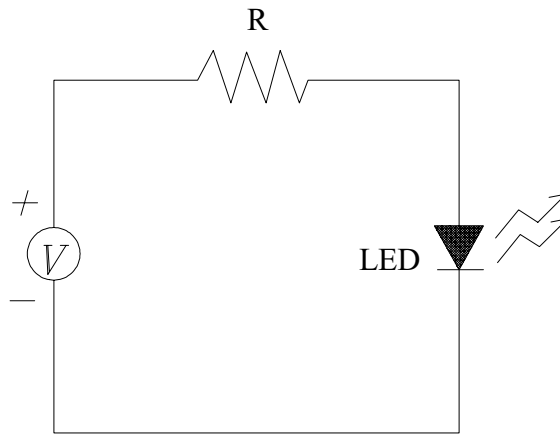

■ Precautions For Use

1. Over-current-proof

Customer must apply resistors for protection , otherwise slight voltage shift will cause big current change (Burn out will happen).

2. Storage time

2.1 The operation of temperature and R.H. are : $5^{\circ}\text{C}\sim 35^{\circ}\text{C}$, R.H.60%.

2.2 Once the package is opened, the products should be used within a week.

Otherwise, they should be keeping in a damp proof box with desiccants.

Considering the tape life , we suggest our customers to use our products within a year(from production date).

2.3 If opened more than one week in an atmosphere $5^{\circ}\text{C}\sim 35^{\circ}\text{C}$, R.H.60%, they should be treated at $60^{\circ}\text{C}\pm 5^{\circ}\text{C}$ for 15hrs.

2.4 When you discover that the desiccant in the package has a pink color (normal = blue) , you should treat them in the same conditions as 2.3.

■ **Soldering heat reliability (DIP)**

Please refer to the following figure :

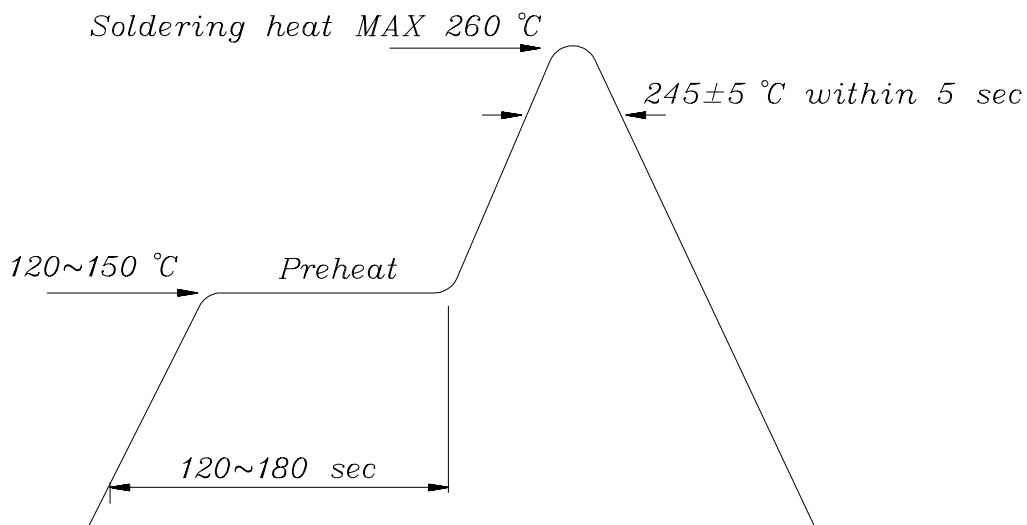

■ **Soldering Iron**

Basic spec is ≤ 5 sec when 260°C . If temperature is higher, time should be shorter ($+10^{\circ}\text{C} \rightarrow -1\text{sec}$). Power dissipation of iron should be smaller than 15 W , and temperature should be controllable. Surface temperature of the device should be under 230°C .

■ **Rework**

1. Customer must finish rework within 5 sec under 260°C .
2. The head of iron can not touch copper foil.
3. Twin-head type is preferred.

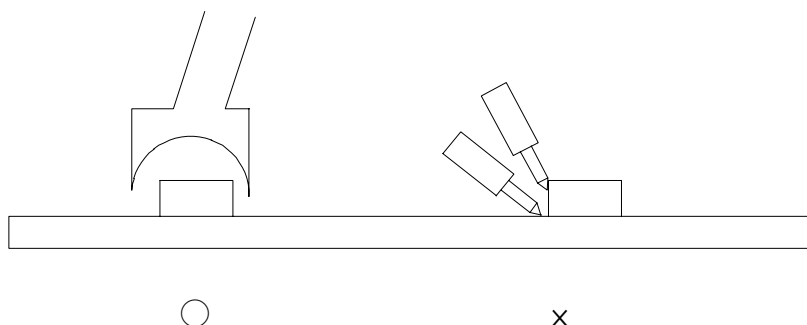



MODEL NO: 17-215SURC/S530-A2/TR8

Device Number : DSE-175-014 REV. 1.0

0.8mm Height Flat Top LEDs

ECN : Page: 8/8

■ Reflow Temp / Time :

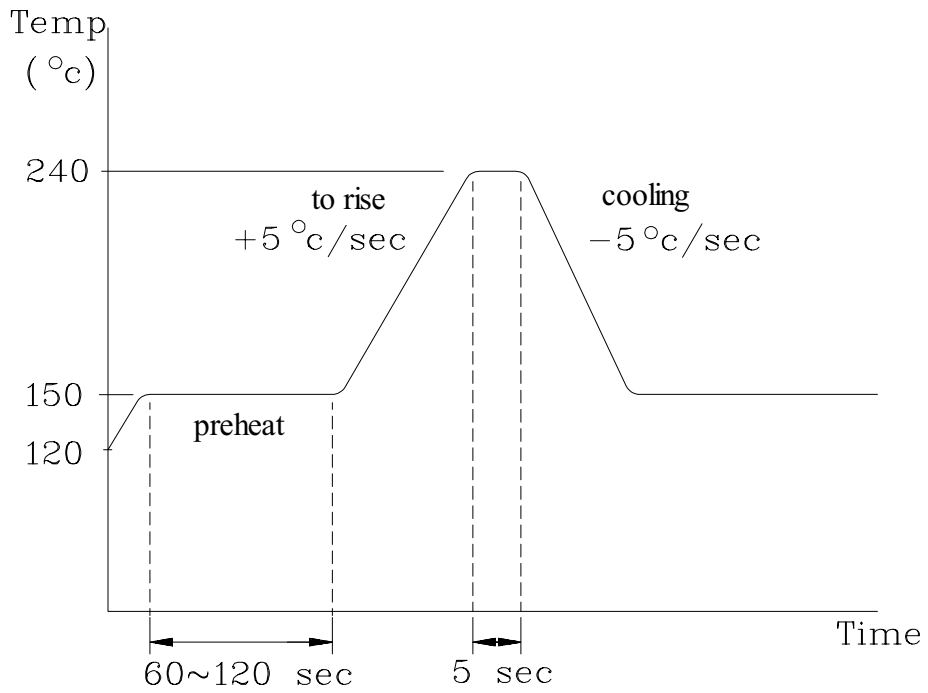

X-ON Electronics

Largest Supplier of Electrical and Electronic Components

Click to view similar products for [Standard LEDs - SMD category](#):

Click to view products by [Everlight manufacturer](#):

Other Similar products are found below :

[LTST-C19GD2WT](#) [LTST-N683GBEW](#) [597-3006-607F](#) [597-3403-607F](#) [LTW-K140SZR40](#) [LTW-M140ZVS](#) [598-8110-100F](#) [598-8170-100F](#)
[598-8610-202F](#) [7012X7](#) [AAAF5060QBFSEEZGS](#) [12-22SURSYGC/S530-A3/E2/TR8](#) [1383SURT/S530-A3/TR1\(R\)](#) [APT1608QGW](#)
[EASV1803BA0](#) [SML310BATT86](#) [SML-512VWT86A](#) [SML-LX0606SISUGC/A](#) [SML-LXL1307SRC-TR](#) [SML-LXR851SIUPGUBC](#)
[LT1ED53A](#) [17-21/G6C-FM1N2B/3T](#) [FAT801-S](#) [SSL-LXA227IC-TR31A](#) [AM27ZGC03](#) [APB3025SGNC](#) [APHK1608VGCA](#) [APT2012QGW](#)
[CLMVC-FKA-CA1E1L81BB7C3C3](#) [CLYBA-FKA-CFHHL9BBB7A363](#) [CMD11504UR](#) [LTW-020ZDCG](#) [LTW-21TS5](#) [LTW-K140SZR30](#)
[HSMY-C177](#) [UYGT801-S](#) [KVH1C100MF6R](#) [42-21SYGC/S530-E1/TR8](#) [YGFR411-H](#) [597-2311-402F](#) [597-2712-602F](#) [5973212407NF](#)
[597-3302-607F](#) [597-5202-407F](#) [598-8330-117F](#) [SAW8WA2A-L35M40-CA](#) [SML013WBDW1](#) [SML-LX0402IC-TR](#) [CLMVC-FKA-](#)
[CLBDGL7LBB79353](#) [VLMKG3400-GS08](#)