

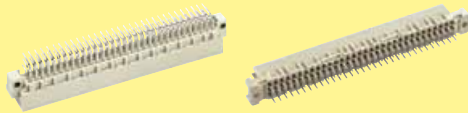

Types B, 2B, C, 2C, M, Q, 2Q, R, R (HE 11), 2R

Page

Technical characteristics .....		<b>01.10</b>
Type B connectors .....		<b>01.11</b>
Type 2B connectors .....		<b>01.16</b>
Type C connectors .....		<b>01.18</b>
Pin shroud type C .....		<b>01.24</b>
Application examples .....		<b>01.25</b>
Type 2C connectors .....		<b>01.26</b>
Type M connectors .....		<b>01.28</b>
Special contacts type M .....		<b>01.30</b>
Type M-flat connectors .....		<b>01.32</b>
Type R connectors .....		<b>01.34</b>
Type R (HE 11) connectors .....		<b>01.36</b>
Type Q, 2Q and 2R connectors .....		<b>01.38</b>
Coding systems .....		<b>01.42</b>

Number of contacts	16-96
Contact spacing (mm)	2.54
Working current see current carrying capacity chart	2 A max. 1 A with insulation displacement 40 A max. type M
Clearance	≥ 1.2 mm
Creepage	≥ 1.2 mm
Working voltage The working voltage also depends on the clearance and creepage dimensions of the pcb itself, and the associated wiring	according to the safety regulations of the equipment Explanations see chapter 00
Test voltage $U_{r.m.s.}$	1 kV
Contact resistance	≤ 15 mΩ for wire wrap connection ≤ 20 mΩ including crimp connection
Insulation resistance	≥ 10 <sup>12</sup> Ω
Temperature range The higher temperature limit includes the local ambient and heating effects of the contacts under load	- 55 °C ... + 125 °C
Degree of protection for crimp terminal IP 20 according to DIN 40 050	
Electrical termination	
Male connector	Solder pins for pcb connections Ø 1.0 ± 0.1 mm according to IEC 60 326-3 For pcb connection Ø 0.8 + 0.3 mm on request wrap posts 0.6 x 0.6 mm diagonal 0.79-0.86 mm
Female connector	wrap posts 0.6 x 0.6 mm diagonal 0.79-0.86 mm Solder pins for pcb connections Ø 1.0 ± 0.1 mm according to IEC 60 326-3 For pcb connection Ø 0.8 + 0.3 mm on request Crimp terminal 0.09-0.5 mm <sup>2</sup> Insulation displacement connection AWG 28/7
Insertion and withdrawal force	16way ≤ 15 N 32way ≤ 30 N 48way ≤ 45 N 64way ≤ 60 N 96way ≤ 90 N
Materials	
Mouldings	Thermoplastic resin, glass-fibre filled, UL 94-V0
Contacts	Copper alloy
Contact surface	
Contact zone	Selectively plated according to performance level <sup>1)</sup>
<sup>1)</sup> Explanation performance levels see chapter 00	

### Current carrying capacity

The current carrying capacity is limited by maximum temperature of materials for inserts and contacts including terminals. The current capacity curve is valid for continuous, non interrupted current loaded contacts of connectors when simultaneous power on all contacts is given, without exceeding the maximum temperature.

Control and test procedures according to DIN IEC 60 512

Ambient temperature (°C)	Working current (A)
20	2.0
30	1.8
40	1.6
50	1.4
60	1.2
70	1.0
80	0.8
90	0.6
100	0.5
110	0.4
120	0.3
125	0.2

### Pin shroud for female connectors with 0.6 x 0.6 mm pins

A secure interfacing system for signals from the rear of 19" racks to connectors with wrap posts 0.6 x 0.6 mm is possible with the use of a pin shroud.

The pin shroud protects the wrap posts on the rear side of the rack and can be screwed to the printed circuit board.

After assembly the rear ends of the wire wrap posts become the mating areas of the type C male connector.

This system can now accept:

- female connectors type C
- female connectors type R

The locking levers provide security for the mated connectors. Fast and simple disconnection is possible.

### Fitting and removing crimp contacts

see technical characteristics chapter 02

Number of contacts

64, 32



Male connectors

Identification	Number of contacts	Contact arrangement	Part No.	Performance levels according to IEC 60 603-2. Explanation chapter 00		
				3	2	1
Male connector with angled solder pins	64		09 02 164 7921	09 02 164 6921 09 02 364 6921 <sup>b)</sup> 09 02 664 6921 <sup>c)</sup>	09 02 164 2921	
	32		09 02 132 7921	09 02 132 6921	09 02 132 2921	
	32		09 02 132 7931	09 02 132 6931	09 02 132 2931	
	62 + 2 <sup>▲</sup>		09 02 164 7951	09 02 164 6951	09 02 164 2951	
Male connector with straight solder pins	64		09 02 164 7922	09 02 164 6922	09 02 164 2922	
	32		09 02 132 7922	09 02 132 6922	09 02 132 2922	
	32		09 02 132 7932	09 02 132 6932	09 02 132 2932	
	62 + 2 <sup>▲</sup>		09 02 164 7952	09 02 164 6952	09 02 164 2952	

Dimensions

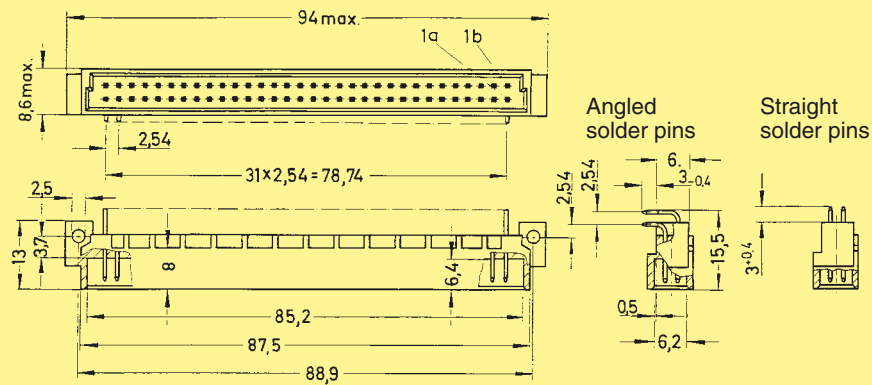

Board drillings

Mounting side

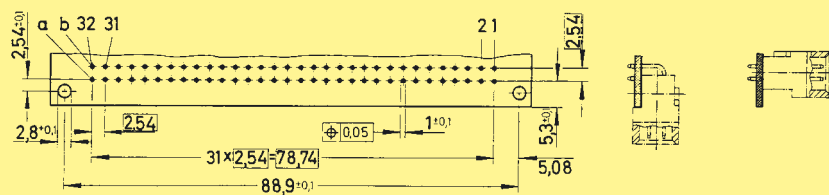

Dimensions in mm

▲ Male connectors with 2 leading contacts [(0.8 mm) pos. a1 and a32]  
 Other contact arrangements on request  
 b) Connectors with snap-in clips see chapter 00  
 c) Connectors with coding see page 01.42

Number of contacts

# 64

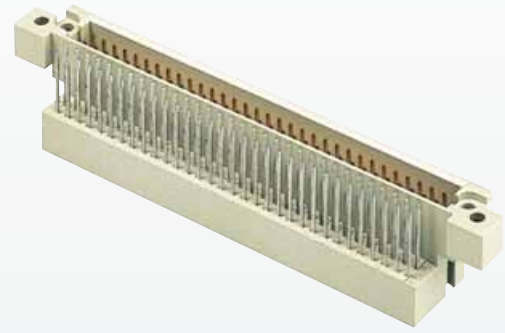

## Interface connector U

DIN Signal to 2 A

Identification	Number of contacts	Part No.	Drawing	Dimensions in mm
----------------	--------------------	----------	---------	------------------

Interface connector U with wrap posts  
0.6 x 0.6 mm

64

Performance level 1 acc. to IEC 60 603-2  
09 02 064 2981

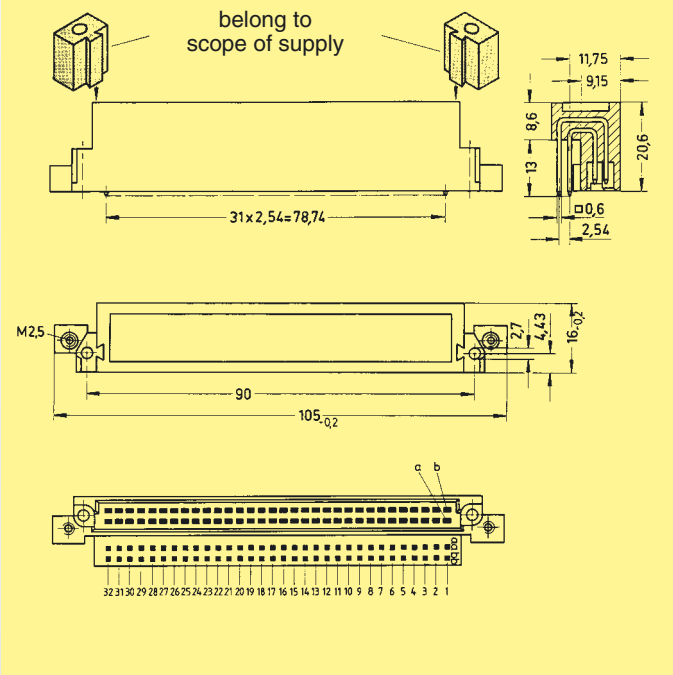

Locking screw

09 02 000 9923<sup>1)</sup>

<sup>1)</sup> Order 2 pieces for one interface connector U

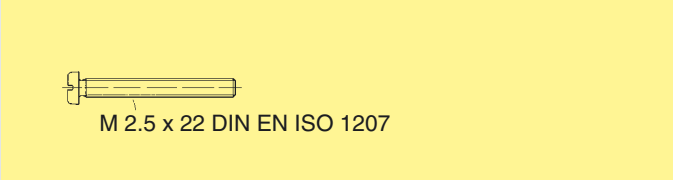

Mounting example

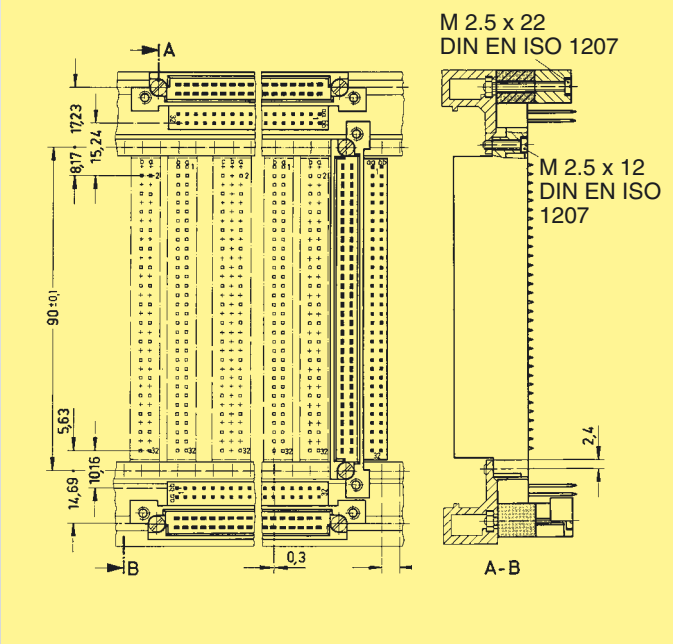
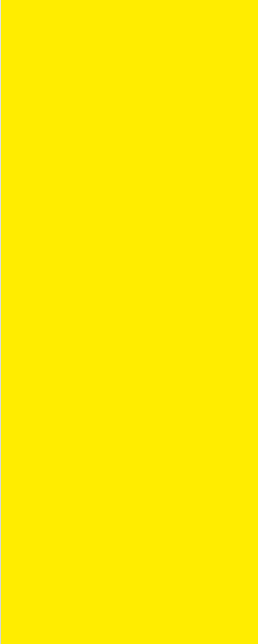

Number of contacts

# 64

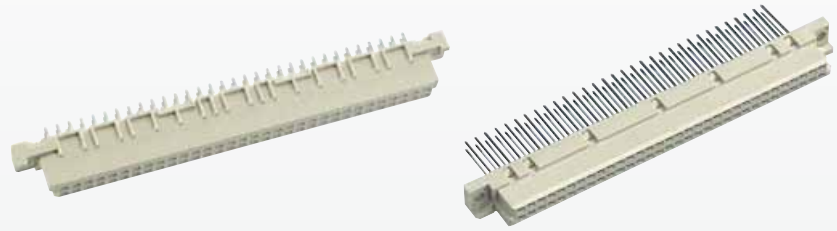

## Female connectors

Identification	Number of contacts	Contact arrangement	Part No.	Performance levels according to IEC 60 603-2. Explanation chapter 00		
				3	2	1
Female connector with solder pins 2.9 mm	64		Performance level 3 on request	09 02 264 6824 09 02 464 6824 <sup>b)</sup> 09 02 764 6824 <sup>c)</sup>	Performance level 1 on request	
Female connector with solder pins 4.5 mm	64			09 02 264 6825		
Female connector with wrap posts 13 mm	64			09 02 264 6821		

## Female connector with press-in pins

Part Nos. and variants see chapter 04

## Dimensions

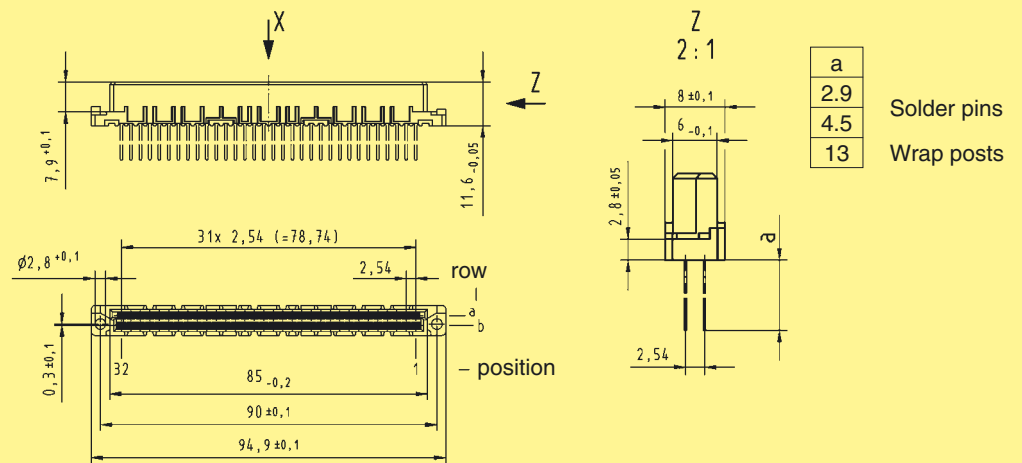

## Panel cut out

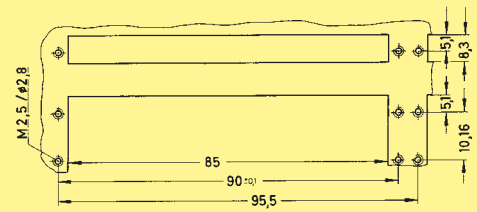

## Board drillings Mounting side

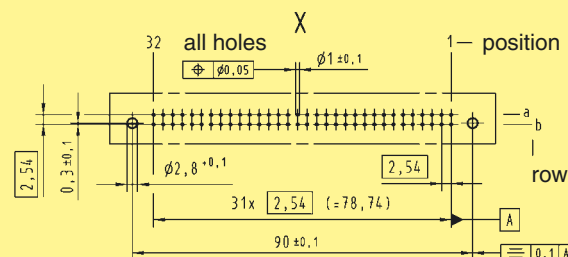

Identification strips for female connectors with wrap posts 09 02 000 9939

Dimensions in mm

DIN Signal to 2 A

Wrap posts selectively gold plated on request  
 Other contact arrangements on request  
<sup>b)</sup> Connectors with snap-in clips see chapter 00  
<sup>c)</sup> Connectors with coding see page 01.42

Number of contacts

# 64

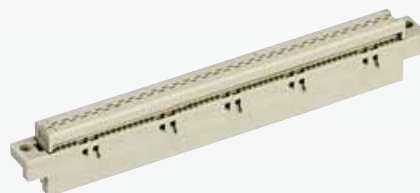

## Female connectors

DIN Signal to 2 A

Identification	Number of contacts	Part No.	Drawing	Dimensions in mm
Female connector for insulation displacement	64	Performance level 2 <sup>1)</sup> 09 02 264 6828  Performance level 3 <sup>1)</sup> 09 02 264 7828	<p>Cable 1 to contact 1 b Contact arrangement View from termination side</p>	
Panel cut out				
Flat cable AWG 28/7  grey 50.00 m grey 150.00 m colour coded 30.48 m twisted pair <sup>1)</sup> 30.48 m	64	09 18 064 7001 09 18 064 7004 09 18 064 7005 09 18 064 7006		1) Termination area spacing = 508 mm  <b>Important: always store reels vertically</b>  Wire (tinned) Cu Gauge AWG 28/7 0.089 mm <sup>2</sup> Insulation material as per UL style PVC
Round flat cable <sup>2)</sup> with screening 30 m screening 150 m  without screening 30 m screening 150 m	64	09 18 064 7007 09 18 064 7010  09 18 064 7008 09 18 064 7011		2) Termination area spacing = 100 mm
Bench press		09 99 000 0114		
Base plate		09 99 000 0150		
Cable cutter		09 99 000 0116		
Spare parts				
Blade		09 99 000 0179		
Cutting plate		09 99 000 0180		

Number of contacts

max. 64



Female connectors

DIN Signal to 2 A

Identification	Number of contacts	Part No.	Drawing	Dimensions in mm
<b>Female connector for crimp contacts</b> Order contacts separately	64	09 02 064 3214	<p>85, 84, 11.6, 11, 6, 2.9<sup>+0.5</sup>, 7.5, 90<sup>±0.1</sup>, 2.8<sup>+0.1</sup>, 1b, 1a, 2.54, 31x2.54=78.74, 95<sup>-0.4</sup>, 2.54, 5, 6.1<sup>-0.2</sup></p> <p>Contact arrangement View from termination side</p> <p>32 31 30 29 28 27 26 25 24 23 22 21 20 19 18 17 16 15 14 13 12 11 10 9 8 7 6 5 4 3 2 1</p>	
Shell housing 09 02 064 0501 / 09 02 064 0502 see chapter 20				

Identification	Part No.	Performance levels according to IEC 60 603-2.
	2	1
<b>Female crimp contacts BC</b>		
Bandoliered contacts (approx. 5,000 pieces)	09 02 000 6484	09 02 000 6474
Bandoliered contacts (approx. 500 pieces)	09 02 000 8434	09 02 000 8444
Individual contacts <sup>1)</sup>	09 02 000 8484	09 02 000 8474
	Wire gauge mm <sup>2</sup> AWG      Insulation ø mm 0.09 - 0.5      28 - 20      0.7 - 1.5	<p>Bandoliered contacts</p> <p>Individual contacts</p>
	3.5 + 0.5 mm of insulation is stripped Insertion, removal and crimping tools see chapter 30	

<sup>1)</sup> Packaging unit 1,000 pieces

Number of contacts

# 32, 16



Male connectors

DIN Signal to 2 A

Identification      Number of contacts      Contact arrangement      Part No.      Performance levels according to IEC 60 603-2. Explanation chapter 00

Identification	Number of contacts	Contact arrangement	Part No.	Performance levels according to IEC 60 603-2. Explanation chapter 00	3	2	1
Male connector with angled solder pins	32		09 22 132 7921	09 22 132 6921 09 22 332 6921 <sup>b)</sup>			09 22 132 2921
	16		09 22 116 7931	09 22 116 6931			09 22 116 2931
	30 + 2 <sup>▲</sup>		09 22 132 7951	09 22 132 6951			09 22 132 2951
Male connector with straight solder pins	32		09 22 132 7922	09 22 132 6922			09 22 132 2922
	16		09 22 116 7932	09 22 116 6932			09 22 116 2932
	30 + 2 <sup>▲</sup>		09 22 132 7952	09 22 132 6952			09 22 132 2952

Dimensions

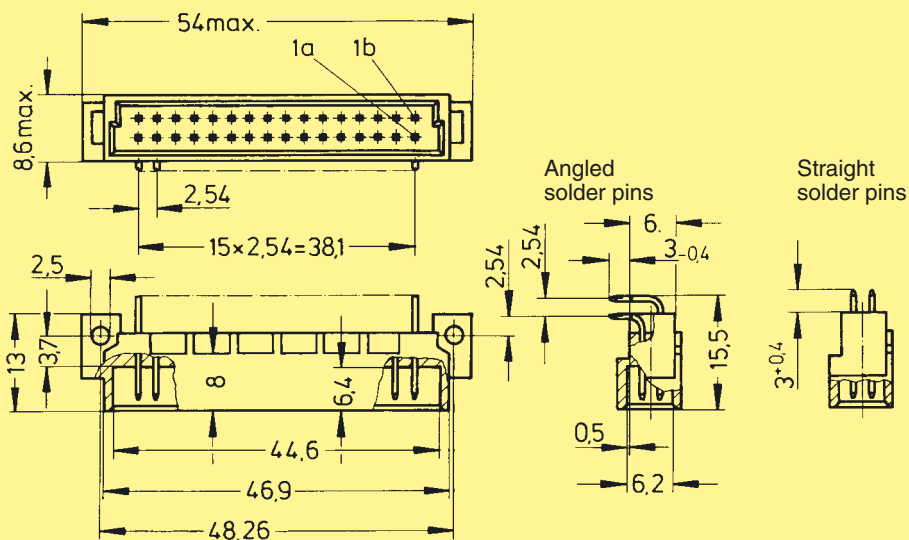

Board drillings  
Mounting side

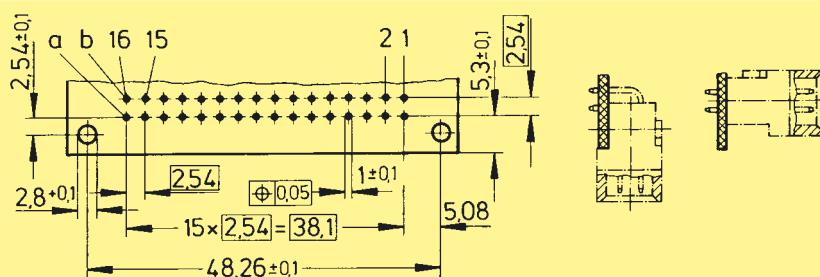

Dimensions in mm

▲ Male connectors with 2 leading contacts [(0.8 mm) pos. a1 and a16]  
Other contact arrangements on request

b) Connectors with snap-in clips see chapter 00



Number of contacts

# 32

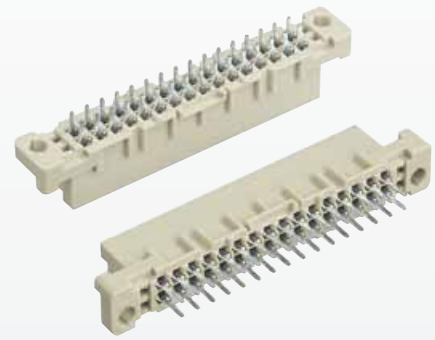

## Female connectors

Identification	Number of contacts	Contact arrangement	Part No.	Performance levels according to IEC 60 603-2. Explanation chapter 00		
				3	2	1
Female connector with solder pins 2.9 mm	32		Performance level 3 on request	09 22 232 6824	Performance level 1 on request	
Female connector with solder pins 4.5 mm	32			09 22 232 6825		

Female connector with press-in pins

Part Nos. and variants see chapter 04

## Dimensions

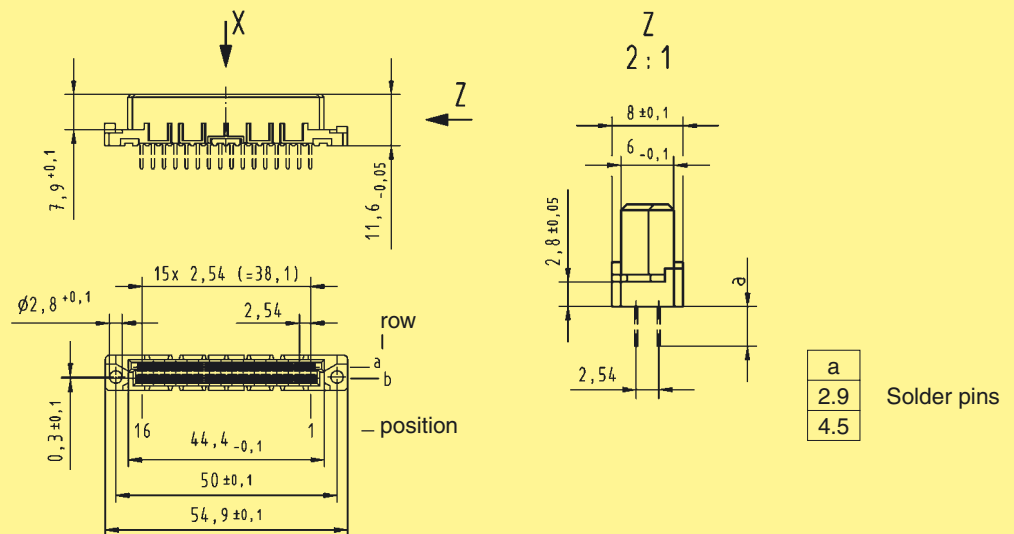

## Board drillings

Mounting side

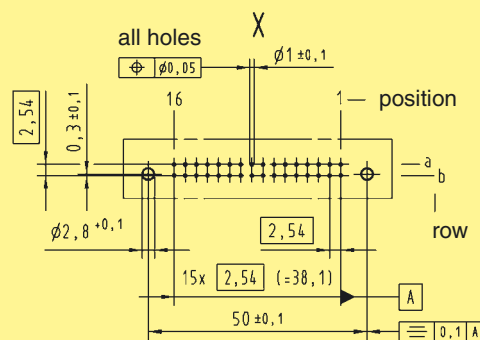

Dimensions in mm

Further components and accessories for insulation displacement see interface catalogue  
 Other contact arrangements on request  
<sup>b)</sup> Connectors with snap-in clips see chapter 00

Number of contacts

96, 64, 32

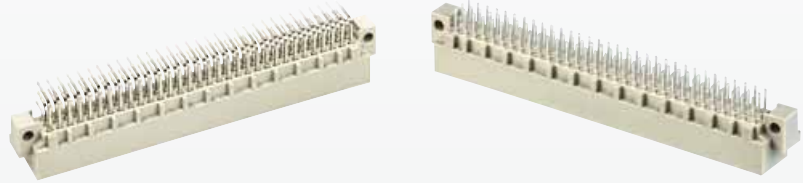

Male connectors

Identification	Number of contacts	Contact arrangement	Part No.	Performance levels according to IEC 60 603-2. Explanation chapter 00		
				3	2	1
Male connector with angled solder pins	96		09 03 196 7921 09 03 396 7921 <sup>b)</sup>	09 03 196 6921 09 03 396 6921 <sup>b)</sup> 09 03 696 6921 <sup>c)</sup>	09 03 196 2921 09 03 396 2921 <sup>b)</sup> 09 03 696 2921 <sup>c)</sup>	
	64		09 03 164 7921 09 03 364 7921 <sup>b)</sup>	09 03 164 6921 09 03 364 6921 <sup>b)</sup> 09 03 664 6921 <sup>c)</sup>	09 03 164 2921 09 03 364 2921 <sup>b)</sup> 09 03 664 2921 <sup>c)</sup>	
	32		09 03 132 7921 09 03 332 7921 <sup>b)</sup>	09 03 132 6921 09 03 332 6921 <sup>b)</sup>	09 03 132 2921 09 03 332 2921 <sup>b)</sup>	
	94 + 2 <sup>▲</sup>		09 03 196 7951	09 03 196 6951 09 03 396 6951 <sup>b)</sup>	09 03 196 2951	
	62 + 2 <sup>▲</sup>		09 03 164 7951	09 03 164 6951	09 03 164 2951	
Male connector with straight solder pins	96		09 03 196 7922	09 03 196 6922	09 03 196 2922	
	64		09 03 164 7922	09 03 164 6922	09 03 164 2922	

Dimensions

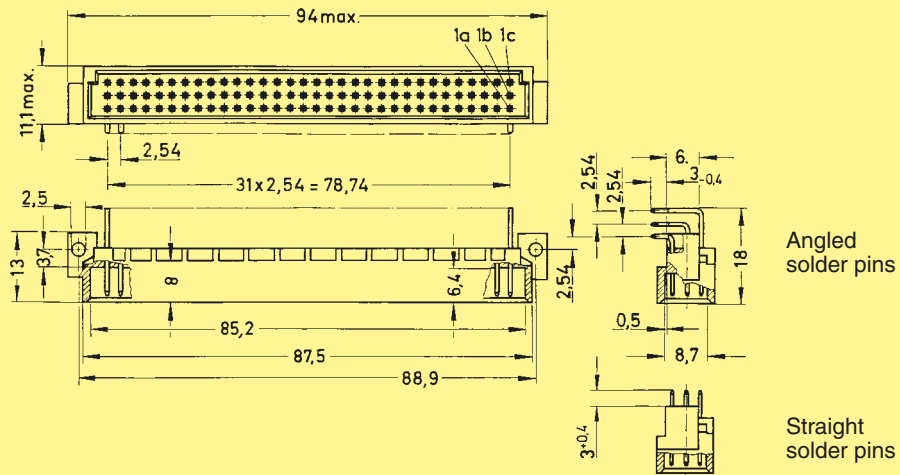

Board drillings  
Mounting side

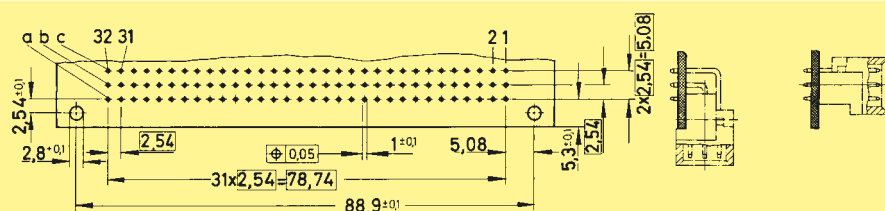

Dimensions in mm

▲ Male connectors with 2 leading contacts [(0.8 mm) pos. a1 and a32]  
High temperature connectors see chapter 05  
b) Connectors with snap-in clips see chapter 00  
c) Connectors with coding see page 01.42

Number of contacts

max. 96

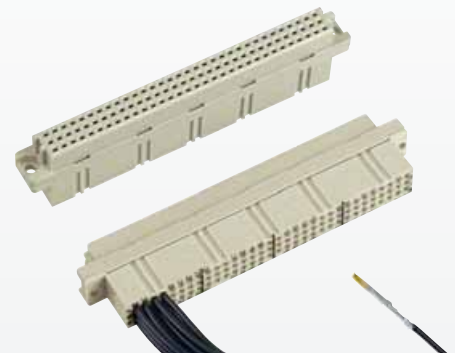

Female connectors

DIN Signal to 2 A

Identification	Number of contacts	Part No.	Drawing	Dimensions in mm
<p>Female connector for crimp contacts</p> <p>Order contacts separately</p>	96	<p>09 03 096 3214</p> <p>09 03 596 3214<sup>c)</sup></p>	<p>85, 84, 90, 95, 11.6, 11, 8.5, 2.9, 10, 2.8, 2.54, 5.1, 10.6, 1.5, 0.2, 0.1, 0.1, 0.4, 0.5, 0.2</p> <p>2 x 2,54 = 5,08</p> <p>31 x 2,54 = 78,74</p> <p>95 - 0,4</p> <p>1c 1b 1a</p>	<p>32 31 30 29 28 27 26 25 24 23 22 21 20 19 18 17 16 15 14 13 12 11 10 9 8 7 6 5 4 3 2 1</p>
			<p>Shell housing 09 03 096 0501 see chapter 20</p>	

Identification	Part No.	Performance levels according to IEC 60 603-2.	Explanation chapter
		2	1
<p>Female crimp contacts BC</p>			
<p>Bandoliered contacts (approx. 5,000 pieces)</p>	09 02 000 6484		09 02 000 6474
<p>Bandoliered contacts (approx. 500 pieces)</p>	09 02 000 8434		09 02 000 8444
<p>Individual contacts<sup>1)</sup></p>	09 02 000 8484		09 02 000 8474
	<p>Wire gauge mm<sup>2</sup></p> <p>0.09 - 0.5</p>	<p>AWG</p> <p>28 - 20</p>	<p>Insulation ø mm</p> <p>0.7 - 1.5</p>
			<p>Bandoliered contacts</p> <p>Individual contacts</p>
	<p>3.5 + 0.5 mm of insulation is stripped from the wires to be crimped</p> <p>Insertion, removal and crimping tools see chapter 30</p>		

<sup>c)</sup> Connectors with coding see page 01.42

<sup>1)</sup> Packaging unit 1,000 pieces



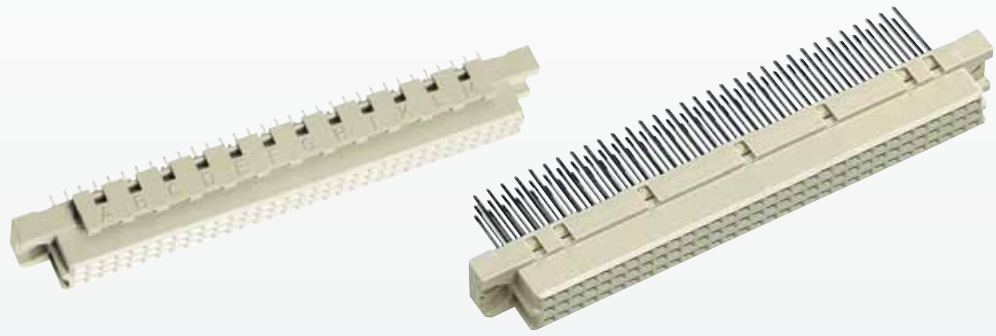

Identification

Drawing

Dimensions in mm

Female connectors  
type C  
DIN 41 612

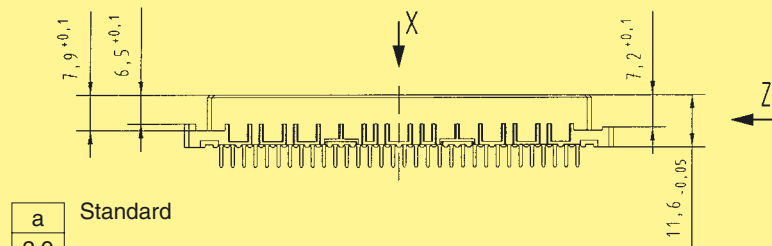

a	Standard
2.9	Solder pins
4.5	Wrap posts

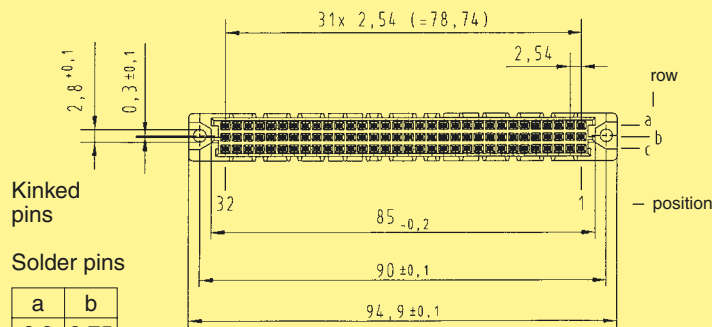
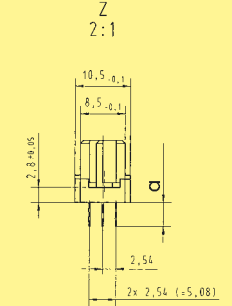

Kinked pins

a	b
2.9	2.75
4.5	4.35

Solder pins

b  $\triangleq$  Length of kinked pins

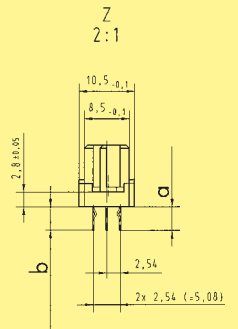

Panel cut out

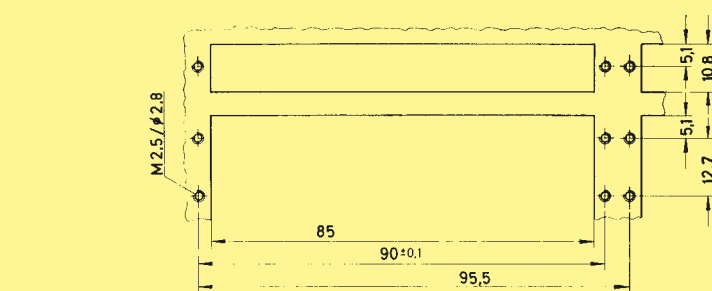

Board drillings  
Mounting side

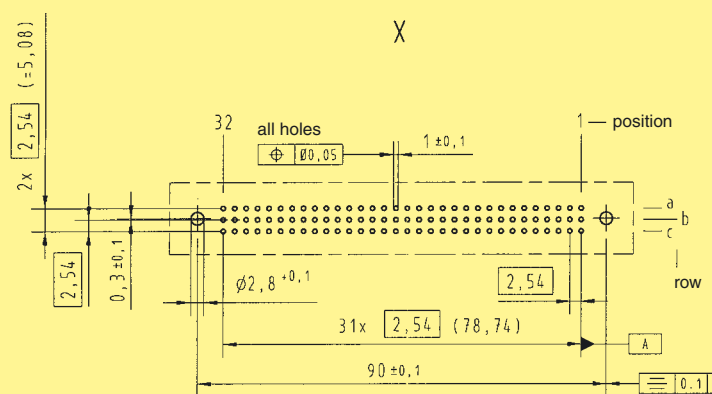

Identification strips for female connectors with wrap posts 09 03 000 9939

Number of contacts

# 64

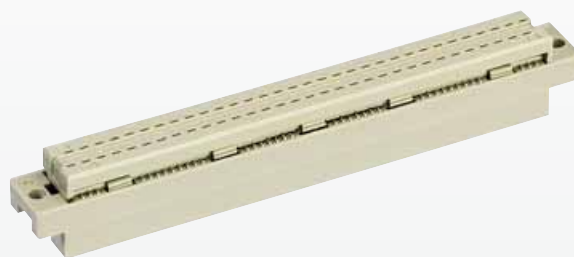

## Female connectors

DIN Signal to 2 A

Identification	Number of contacts	Part No.	Drawing	Dimensions in mm
<b>Female connector for insulation displacement</b>	64	Performance level 2 <sup>1)</sup> 09 03 264 6828 09 03 764 6828 <sup>c)</sup>	<p>Cable 1 to contact 1 c Contact arrangement View from termination side</p>	
<b>Panel cut out</b>		Performance level 3 <sup>1)</sup> 09 03 264 7828		
<b>Flat cable</b> AWG 28/7	64	grey 50.00 m 09 18 064 7001 grey 150.00 m 09 18 064 7004 colour coded 30.48 m 09 18 064 7005 twisted pair <sup>1)</sup> 30.48 m 09 18 064 7006	<p><sup>1)</sup> Termination area spacing = 508 mm</p> <p><b>Important: always store reels vertically</b></p> <p>Wire (tinned) Cu Gauge AWG 28/7 0.089 mm<sup>2</sup> Insulation material as per UL style PVC</p>	
<b>Round flat cable<sup>2)</sup></b> with screening 30 m 09 18 064 7007 screening 150 m 09 18 064 7010 without screening 30 m 09 18 064 7008 screening 150 m 09 18 064 7011		<p><sup>2)</sup> Termination area spacing = 100 mm</p>		
<b>Bench press</b> Base plate		09 99 000 0114 09 99 000 0150		
<b>Cable cutter</b>		09 99 000 0116		
<b>Spare parts</b> Blade Cutting plate	09 99 000 0179 09 99 000 0180			

Further components and accessories for insulation displacement see interface catalogue, chapter 40

<sup>c)</sup> Connectors with coding see page 01.42

<sup>1)</sup> acc. to IEC 60 603-2





Complicated shapes are injected with utmost precision.

Integrated handling robots guarantee that new injected parts are not damaged.

# Pin shroud



Number of contacts

# 96

Pin shrouds/Locking levers for 0.6 x 0.6 mm wrap posts

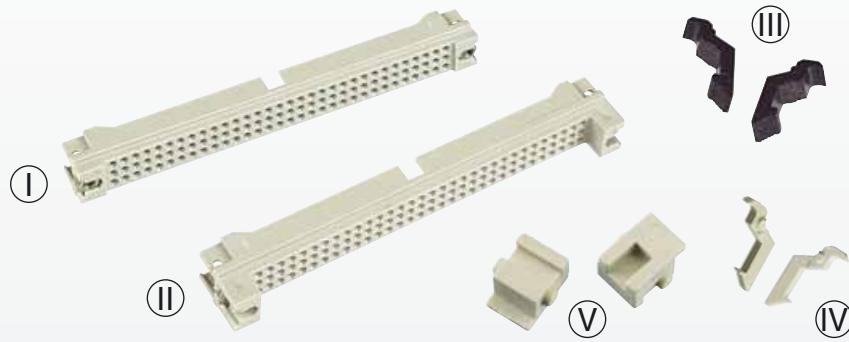

Identification                      Part No.                      Drawing                      Dimensions in mm

## Pin shroud

- Ⓘ for 13 mm wrap posts
- Ⓜ for 17 mm wrap posts
- Ⓝ Locking lever for female connector type C\*

09 03 000 9912  
09 03 000 9915  
09 03 000 9914

### for 13 mm wrap posts

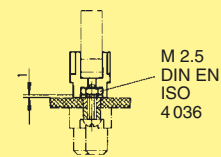
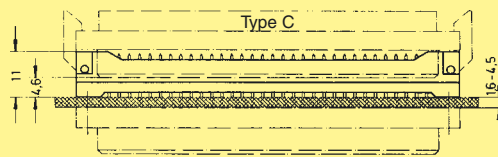

### for 17 mm wrap posts

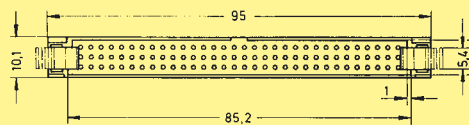
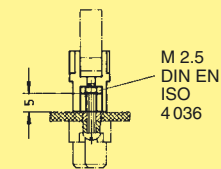
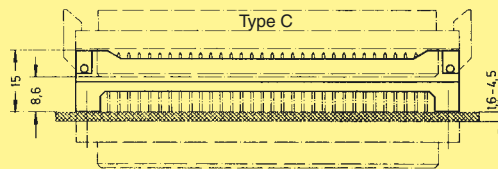

## Pin shroud

- Ⓘ for 13 mm wrap posts
- Ⓜ for 17 mm wrap posts
- Ⓝ Locking lever for female connector type R\*
- Ⓟ Fixing brackets for shell housing C\*

09 03 000 9912  
09 03 000 9915  
09 03 000 9913  
09 03 000 9921

### for 13 mm wrap posts

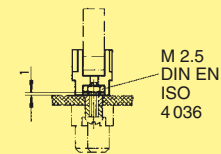
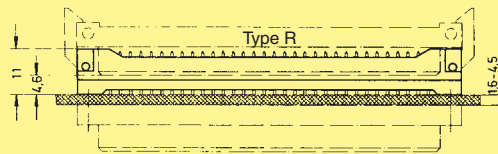

### for 17 mm wrap posts

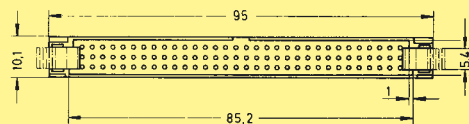
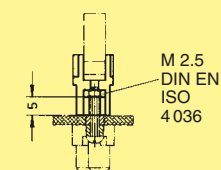
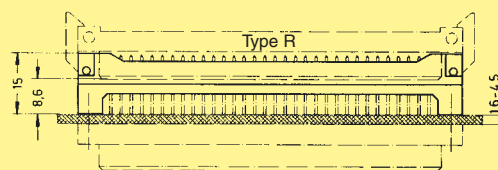

Height adjustment of the pin shroud for different pcb thickness with washers is possible. The mating length can be calculated as follows:

$$\text{Mating length} = 8.4 \text{ mm} - \text{pcb thickness} - \text{washers thickness}$$

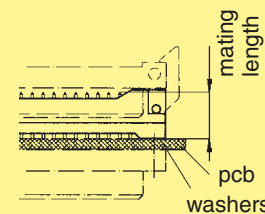

\* order 2 pieces per connector



## Application 1

Female connector  
09 03 296 6861

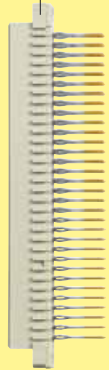

Backplane

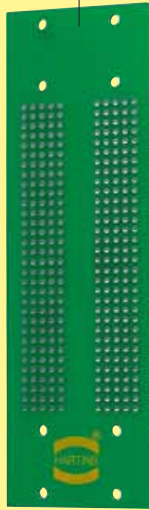

Pin shroud  
09 03 000 9912



Locking lever  
09 03 000 9914



Female connector  
09 03 264 6828



Female connector  
09 03 096 3214



DIN Signal  
to 2 A

## Application 2

Female connector  
09 03 296 6862

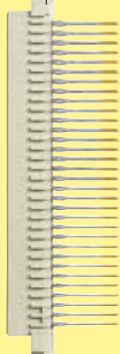

Backplane

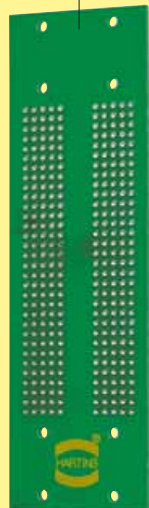

Pin shroud  
09 03 000 9915



Locking lever  
09 03 000 9913



Female connector  
09 73 296 6801



Daughtercard

## Application 3

Female connector  
09 03 296 6861



Backplane

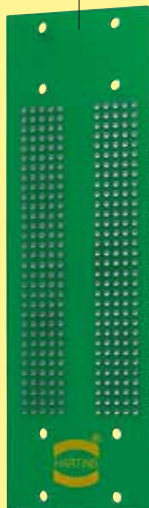

Pin shroud  
09 03 000 9912



Fixing brackets  
09 03 000 9921



Female connector  
09 03 096 3214



Locking levers  
left 09 02 000 9902  
right 09 02 000 9903

Shell housing C  
09 03 096 0501

Number of contacts

# 48, 32, 16

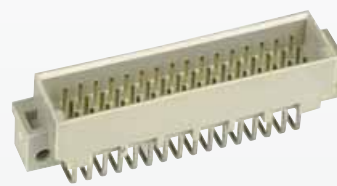

## Male connectors

DIN Signal to 2 A

Identification	Number of contacts	Contact arrangement	Part No.	Performance levels according to IEC 60 603-2. Explanation chapter 00		
				3	2	1
Male connector with angled solder pins	48		09 23 148 7921 09 23 348 7921 <sup>b)</sup>	09 23 148 6921 09 23 348 6921 <sup>b)</sup>	09 23 148 2921	
	32		09 23 132 7921 09 23 332 7921 <sup>b)</sup>	09 23 132 6921 09 23 332 6921 <sup>b)</sup>	09 23 132 2921	
	16		09 23 116 7931	09 23 116 6931	09 23 116 2931	
	46 + 2 <sup>▲</sup>		09 23 148 7951	09 23 148 6951	09 23 148 2951	
Male connector with straight solder pins	48		09 23 148 7922	09 23 148 6922	09 23 148 2922	
	32		09 23 132 7922	09 23 132 6922	09 23 132 2922	

## Dimensions

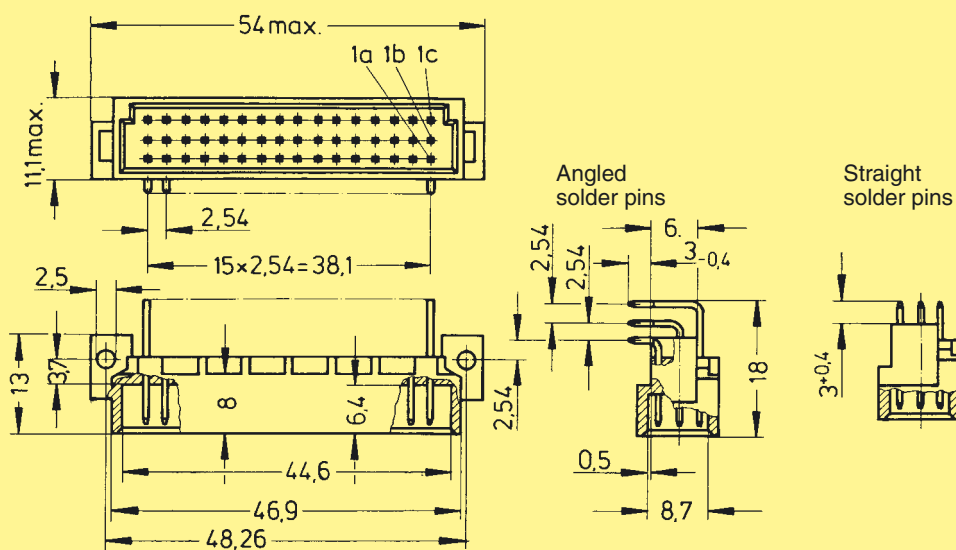

## Board drillings

Mounting side

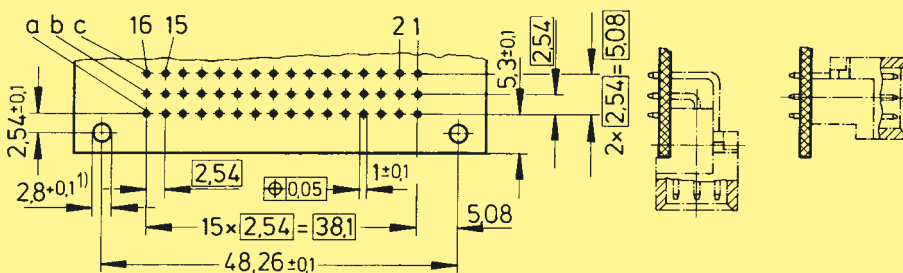

Dimensions in mm

<sup>▲</sup> Male connectors with 2 leading contacts [(0.8 mm) pos. a1 and a16]

Other contact arrangements on request

High temperature connector see chapter 05

<sup>b)</sup> Connectors with snap-in clips see chapter 00



Number of contacts

# 78+2, 60+4, 42+6, 24+8



Male connectors

DIN Signal to 2 A

Identification	Number of contacts	Contact arrangement	Part No.	Performance levels according to IEC 60 603-2. Explanation chapter 00		
				3	2	1
Male connector with angled solder pins (without special contacts)*	78 + 2		09 03 178 7901	09 03 178 6901	09 03 178 2901 09 03 378 2901 <sup>b)</sup>	
	60 + 4		09 03 160 7901	09 03 160 6901	09 03 160 2901	
	42 + 6		09 03 142 7901	09 03 142 6901	09 03 142 2901	
	24 + 8		09 03 124 7901	09 03 124 6901	09 03 124 2901	

## Dimensions

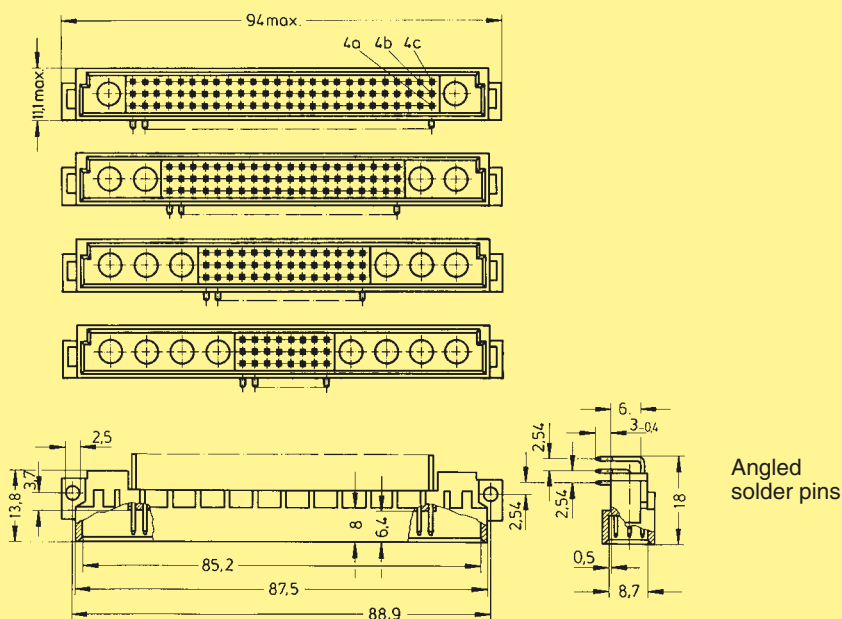

Order high current, high voltage, coaxial and fibre optic contacts separately, see pages 01.30 and 01.31

## Board drillings

Mounting side

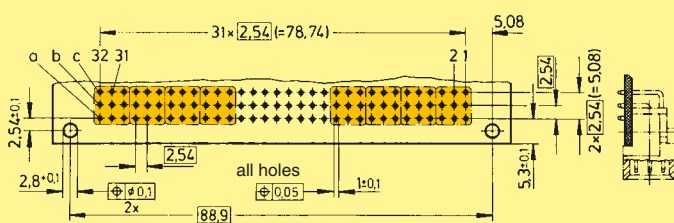

△ Board drillings depend on type and special contact loading

Dimensions in mm

\* Pre-loaded with special contacts on request

<sup>b)</sup> Connectors with snap-in clips see chapter 00

Number of contacts

78+2, 60+4,  
42+6, 24+8

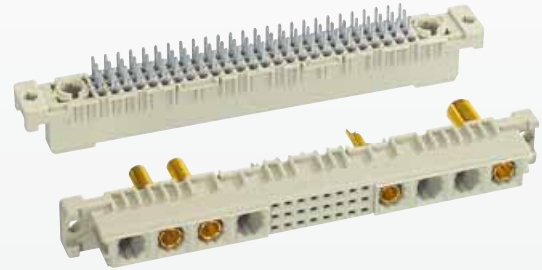

Female connectors

Identification	Number of contacts	Contact arrangement	Part No.	Performance levels according to IEC 60 603-2. Explanation chapter 00		
				3	2	1
Female connector with solder pins 2.9 mm (without special contacts)	78 + 2		Performance level 3 on request	09 03 278 6804	Performance level 1 on request	
	60 + 4			09 03 260 6804		
	42 + 6			09 03 242 6804		
	24 + 8			09 03 224 6804		
Female connector with solder pins 4.5 mm (without special contacts)	78 + 2			09 03 278 6805		
	60 + 4			09 03 260 6805		
	42 + 6			09 03 242 6805		
	24 + 8			09 03 224 6805		

Female connector with press-in pins

Part Nos. and variants see chapter 04

Dimensions

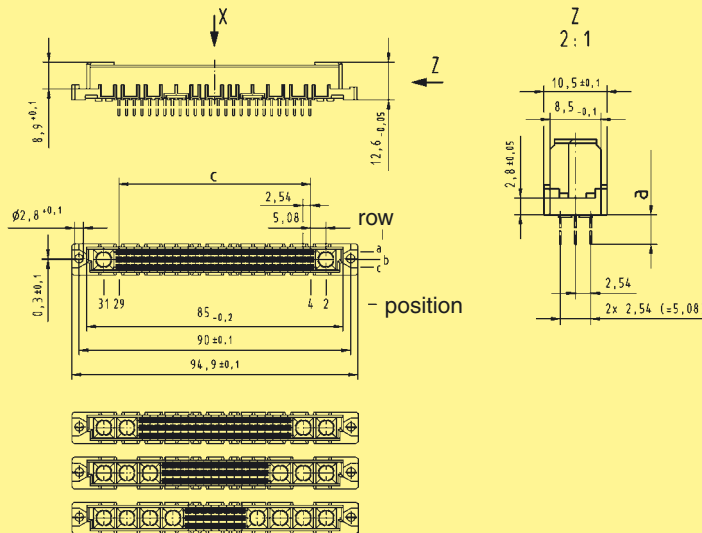

Order high current, high voltage, coaxial and fibre optic contacts separately, see pages 01.30 and 01.31

Board drillings

Mounting side

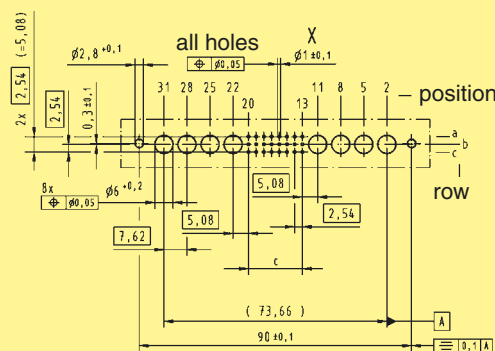

Type	c
78 + 2	25 x 2.54 = 63.5
60 + 4	19 x 2.54 = 48.26
42 + 6	13 x 2.54 = 33.02
24 + 8	7 x 2.54 = 17.78

Dimensions in mm

Other contact arrangements on request

DIN Signal to 2 A

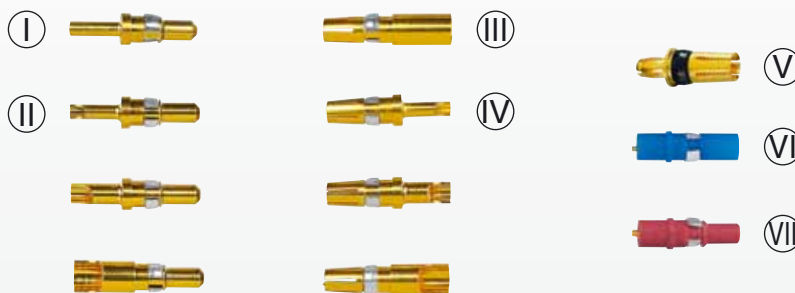

High current contacts  
High voltage contacts

DIN Signal to 2 A

Identification      Part No. Performance level 2      Drawing      Dimensions in mm

**High current male contacts for male connectors<sup>1)</sup>**

I for straight crimp termination	10 A	09 03 000 6113
	20 A	09 03 000 6114
	40 A	09 03 000 6115
Leading contact	10 A	09 03 000 6123
	20 A	09 03 000 6124
	40 A	09 03 000 6125
II for straight solder termination	10 A	09 03 000 6101
	20 A	09 03 000 6102
	40 A	09 03 000 6103
Leading contact	10 A	09 03 000 6111
	20 A	09 03 000 6122
	40 A	09 03 000 6133
for angled pcb termination	max. 40 A*	09 03 000 6104
Leading contact	max. 40 A*	09 03 000 6134

\* depending on the pcb design

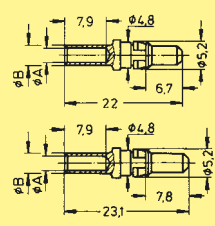

	ø A	ø B	wire gauge [mm <sup>2</sup> ]	AWG
10 A	1.85	2.55	1.5	16
20 A	2.80	3.70	4	12
40 A	4.40	5.60	10	8

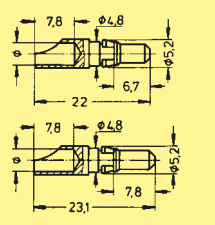

	ø
10 A	1.7
20 A	2.8
40 A	4.8

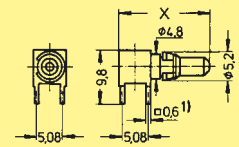

	X
... 6104	17.7
... 6134	18.4

<sup>1)</sup> Solder pins for hole  $\varnothing 1 \pm 0.1$  mm

**High current female contacts for female connectors<sup>2)</sup>**

III for straight crimp termination	10 A	09 03 000 6213
	20 A	09 03 000 6214
	40 A	09 03 000 6215
IV for straight solder termination	10 A	09 03 000 6201
	20 A	09 03 000 6202
	40 A	09 03 000 6203
V for press-in termination for type M-flat	40 A	09 03 000 6250

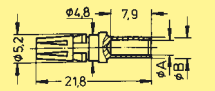

	ø A	ø B	wire gauge [mm <sup>2</sup> ]	AWG
10 A	1.85	2.55	1.5	16
20 A	2.80	3.70	4	12
40 A	4.40	5.60	10	8

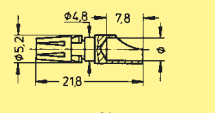

	ø
10 A	1.7
20 A	2.8
40 A	4.8

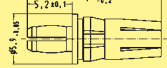

**High voltage male contact for male connectors<sup>3)</sup>**

VI for straight solder termination	2.8 kV	09 03 000 6140
------------------------------------	--------	----------------

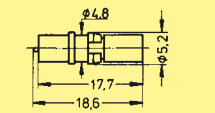

Wire gauge max. 0.5 mm<sup>2</sup>

**High voltage female contact for female connectors<sup>3)</sup>**

VII for straight solder termination	2.8 kV	09 03 000 6240
-------------------------------------	--------	----------------

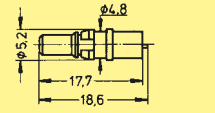

Wire gauge max. 0.5 mm<sup>2</sup>

Crimping tool for high current contacts	09 99 000 0196
---	----------------

<sup>2)</sup> Contact resistance max. 1.5 mΩ  
<sup>3)</sup> Contact resistance internal wire max. 3 mΩ

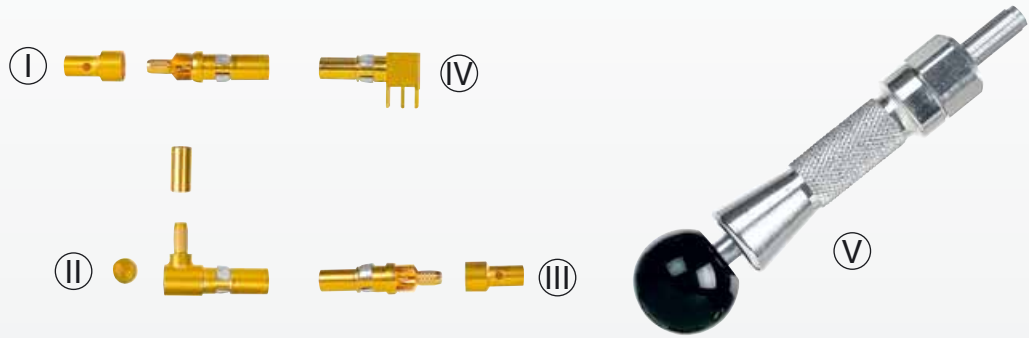

## Coaxial contacts

Identification	Part No. Performance level 2	Drawing	Dimensions in mm
<b>Male coaxial contacts for female connectors</b> (I) for straight solder and/or crimp termination (II) for angled solder and/or crimp termination	09 03 000 6160 09 03 000 6181* 09 03 000 6161		<b>Assembly instruction for contacts (I) and (III)</b> 
<b>Female coaxial contacts for male connectors</b> (III) for straight solder and/or crimp termination (IV) angled for pcb termination	without knurled area 09 03 000 6260 09 03 000 6281* with knurled area 09 03 000 6274 09 03 000 6262 09 03 000 6269*	with/without knurled area <p>1) Solder pins for hole <math>\varnothing 1 \pm 0.1</math> mm</p>	<b>Assembly instruction for contacts (II)</b> 
<b>Crimping tool for coaxial contacts</b>	09 99 000 0194		
<b>Removal tool incl. removal jacket (V) for contact replacement</b>	09 99 000 0174		Insert insulator, press-in or solder closing-washer
<b>Replacement removal jacket</b>	09 99 000 0243		

### Electrical characteristics of 50 Ω coaxial contacts and wires

Impedance	50 Ω
Max. working frequency	2 up to 10 GHz
VSWR-value	1.07 + 0.02 f [GHz]
Proof voltage	750 V / 50 Hz
Working voltage	250 V / 50 Hz
Insulation resistance	≥ 1 GΩ
Contact resistance	– Center contact: 10 mΩ – Outer contact: 3 mΩ
Contact current max.	1.5 A
Admissible power (depends on: frequency, application, VSWR, environmental characteristics)	Data on request
75 Ohm versions	Data on request

Cable group 2 flexible wires	Shell $\varnothing$	Screening $\varnothing$	Dielectric $\varnothing$	Internal wire $\varnothing$	Hexagonal crimp Spanner width
RG 174 A/U	2.5	2.0	1.5	0.48	3.25
RG 188 A/U	2.6	2.0	1.5	0.54	3.25
RG 316 U	2.5	2.0	1.5	0.54	3.25

\* Coaxial contact 75 Ω  
Fibre optic contacts on request









DIN Signal  
to 2 A

Number of contacts

# 96, 64, 32

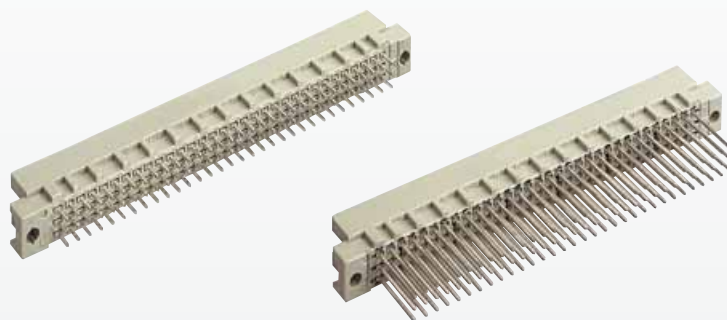

## Male connectors

DIN Signal  
to 2 A

Identification	Number of contacts	Contact arrangement	Part No.	Performance levels according to IEC 60 603-2. Explanation chapter 00		
				3	2	1
Male connector with solder pins 2.5 mm	96		09 73 196 7902	09 73 196 6902	09 73 196 2902	
	94 + 2 <sup>▲</sup>		09 73 196 7952	09 73 396 6902 <sup>b)</sup>	09 73 196 2952	
	64		09 73 164 7902	09 73 164 6902	09 73 164 2902	
	32		09 73 132 7902	09 73 364 6902 <sup>b)</sup>	09 73 364 2902 <sup>b)</sup>	
Male connector with solder pins 4.0 mm	96		09 73 196 7903	09 73 196 6903	09 73 196 2903	
	94 + 2 <sup>▲</sup>		09 73 196 7953	09 73 396 6903 <sup>b)</sup>	09 73 196 2953	
	64		09 73 164 7903	09 73 164 6903	09 73 164 2903	
	32		09 73 132 7903	09 73 364 6903 <sup>b)</sup>	09 73 132 2903	
Male connector with wrap posts 13 mm	96		09 73 196 7907	09 73 196 6907	09 73 196 2907	
	94 + 2 <sup>▲</sup>		09 73 196 7957	09 73 196 6957	09 73 196 2957	
	64		09 73 164 7907	09 73 164 6907	09 73 164 2907	
	32		09 73 132 7907	09 73 132 6907	09 73 132 2907	

## Male connector with press-in pins

Part Nos. and variants see chapter 04

## Dimensions

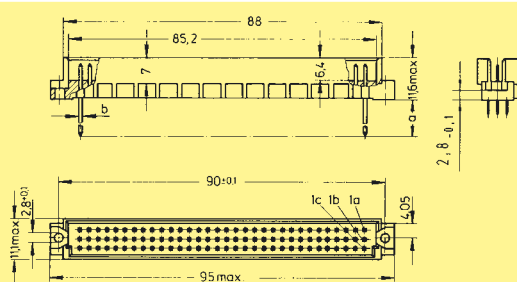

a	b
2.5	∅ 0.7
4	

Solder pins

a	b
13	∅ 0.6

Wrap posts

## Panel cut out

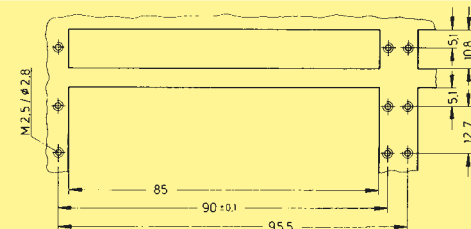

Contact arrangement View from termination side

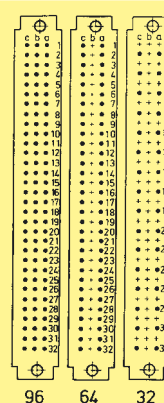

## Board drillings

Mounting side

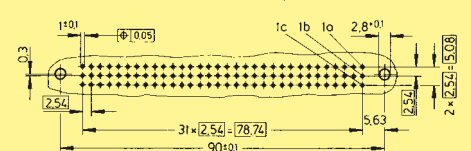

Dimensions in mm

▲ Male connectors with 2 leading contacts [(0.8 mm) pos. a1 and a32]  
Other contact arrangements as well with lagging pins on request  
b) Connectors with snap-in clips see chapter 00

Number of contacts

# 96, 64, 32

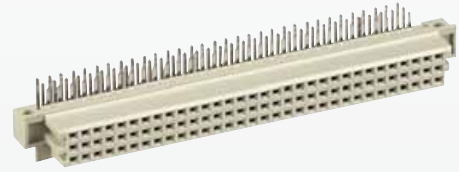

## Female connectors

Identification	Number of contacts	Contact arrangement	Part No. Performance levels according to IEC 60 603-2. Explanation chapter 00		
			3	2	1
Female connector with angled solder pins	96		09 73 296 7801 09 73 496 7801 <sup>b)</sup>	09 73 296 6801 09 73 496 6801 <sup>b)</sup>	09 73 296 2801
	64		09 73 264 7801 09 73 464 7801 <sup>b)</sup>	09 73 264 6801 09 73 464 6801 <sup>b)</sup>	09 73 264 2801
	32		09 73 232 7801	09 73 232 6801	09 73 232 2801
	32		09 73 232 7811	09 73 232 6811	09 73 232 2811

## Dimensions

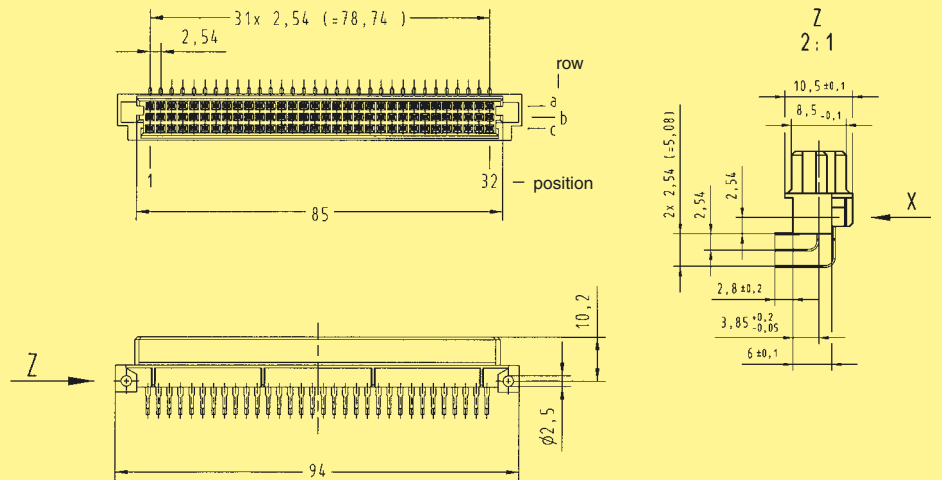

## Board drillings

Mounting side

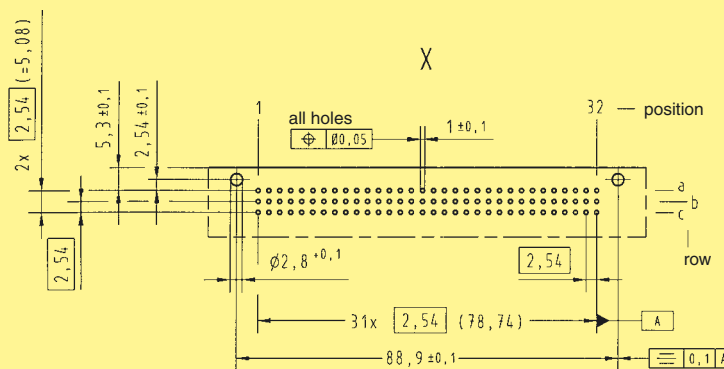

Dimensions in mm

Other contact arrangements on request  
 High temperature connectors see chapter 05  
<sup>b)</sup> Connectors with snap-in clips see chapter 00

DIN Signal to 2 A

# DIN 41 612 · complementary to type R (HE 11)



Number of contacts

# 96, 64, 32

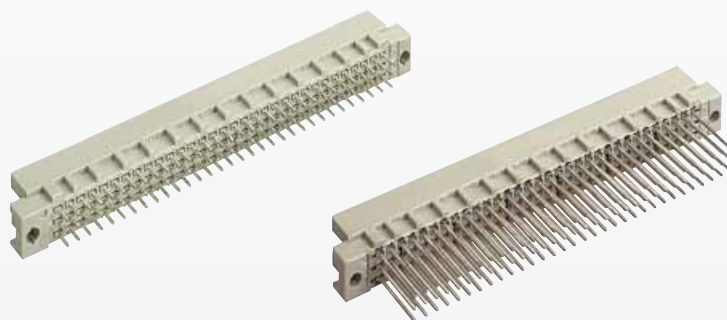

## Male connectors

DIN Signal to 2 A

Identification      Number of contacts      Contact arrangement      Part No.      Performance levels according to IEC 60 603-2. Explanation chapter 00

Identification	Number of contacts	Contact arrangement	Part No.	Performance levels according to IEC 60 603-2. Explanation chapter 00	
				3	2      1
Male connector with solder pins 2.5 mm	96		09 79 196 7902	09 79 196 6902	Performance level 1 on request
	64		09 79 164 7902	09 79 164 6902	
	32		09 79 132 7902	09 79 132 6902	
Male connector with solder pins 4.0 mm	96		09 79 196 7903	09 79 196 6903 09 79 396 6903 <sup>b)</sup>	
	64		09 79 164 7903	09 79 164 6903 09 79 364 6903 <sup>b)</sup>	
	32		09 79 132 7903	09 79 132 6903	
Male connector with wrap posts 13 mm	96		09 79 196 7907	09 79 196 6907	
	64		09 79 164 7907	09 79 164 6907	
	32		09 79 132 7907	09 79 132 6907	

## Dimensions

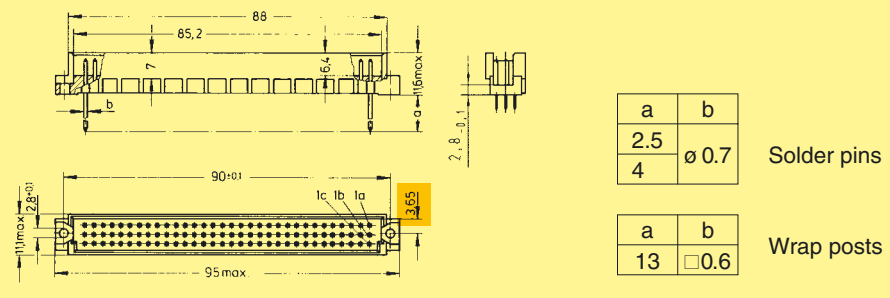

## Panel cut out

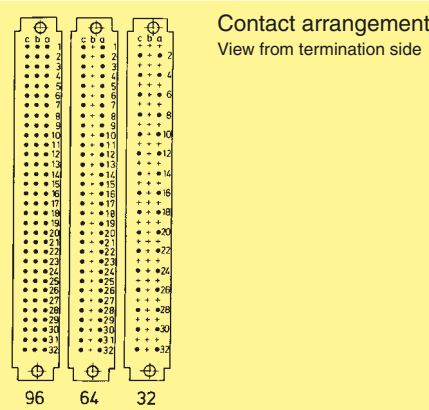
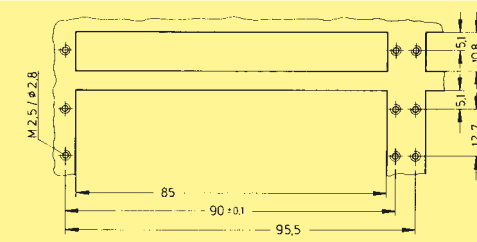

Contact arrangement  
View from termination side

## Board drillings Mounting side

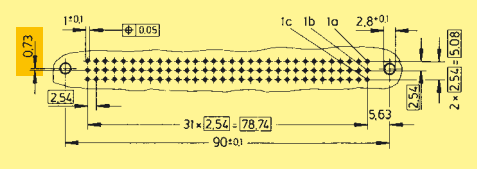

Dimensions in mm

Other contact arrangements on request  
 = deviating dimensions from standard male connectors (see page 01.34)  
<sup>b)</sup> Connectors with snap-in clips see chapter 00



Number of contacts

96, 64

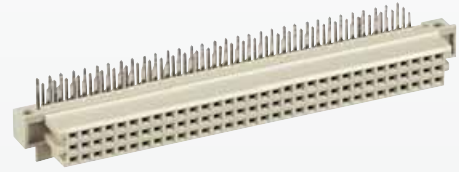

Female connectors

Identification	Number of contacts	Contact arrangement	Part No.	Performance levels according to IEC 60 603-2. Explanation chapter 00		
				3	2	1
Female connector with angled solder pins	96		09 79 296 7801		09 79 296 6801 09 79 496 6801 <sup>b)</sup>	Performance level 1 on request
	64		09 79 264 7801		09 79 264 6801 09 79 464 6801 <sup>b)</sup>	

Dimensions

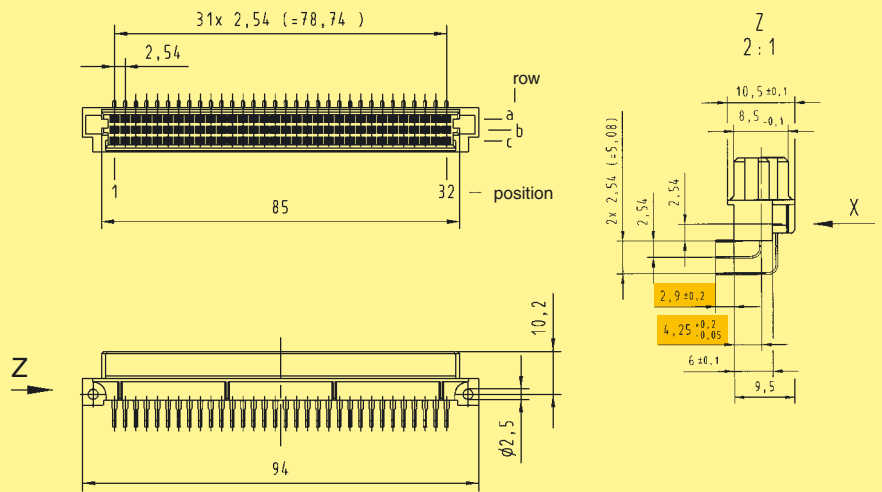

Board drillings

Mounting side

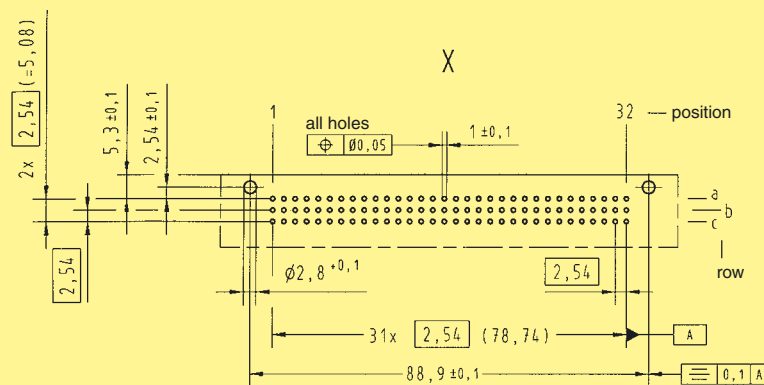

Dimensions in mm

Other contact arrangements on request

= deviating dimensions from standard female connectors (see page 01.35)

<sup>b)</sup> Connectors with snap-in clips see chapter 00

Number of contacts

# 64

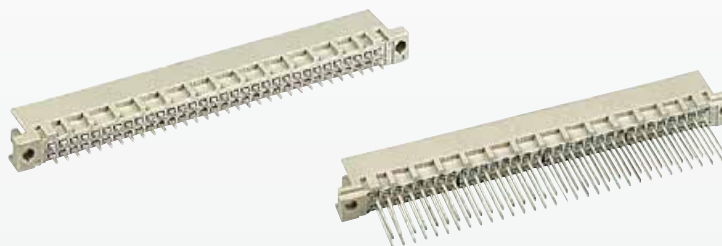

## Male connectors

Identification	Number of contacts	Contact arrangement	Part No.	Performance levels according to IEC 60 603-2. Explanation chapter 00		
				3	2	1
Male connector with solder pins 2.5 mm	64 62 + 2 <sup>▲</sup>		09 72 164 7902 09 72 164 7952	09 72 164 6902 09 72 164 6952	Performance level 1 on request	
Male connector with solder pins 4.0 mm	64 62 + 2 <sup>▲</sup>		09 72 164 7903 09 72 164 7953	09 72 164 6903 09 72 164 6953		
Male connector with wrap posts 13 mm	64 62 + 2 <sup>▲</sup>		09 72 164 7907 09 72 164 7957	09 72 164 6907 09 72 164 6957		

Male connector with press-in pins

Part Nos. and variants see chapter 04

## Dimensions

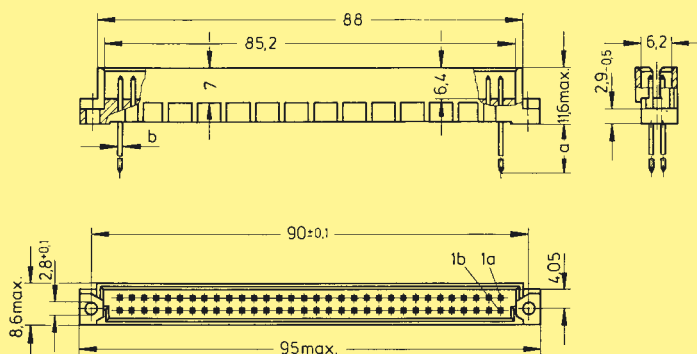

## Panel cut out

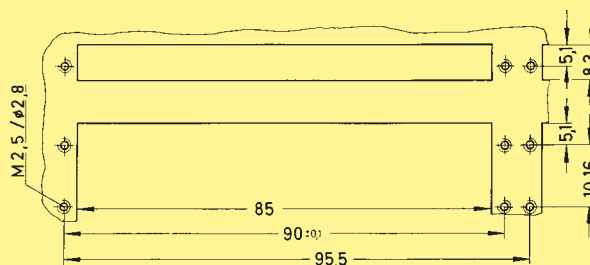

## Board drillings

Mounting side

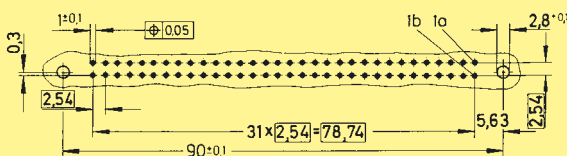

Dimensions in mm

▲ Male connectors with 2 leading contacts [(0.8 mm) pos. a1 and a32]  
Other contact arrangements as well with lagging pins on request

Number of contacts

# 32

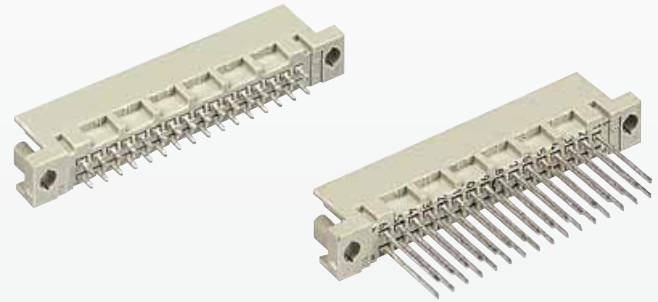

## Male connectors

Identification	Number of contacts	Contact arrangement	Part No.	Performance levels according to IEC 60 603-2. Explanation chapter 00		
				3	2	1
Male connector with solder pins 2.5 mm	32 30 + 2 <sup>▲</sup>		09 27 132 7902 09 27 132 7952	09 27 132 6902 09 27 132 6952	Performance level 1 on request	
Male connector with solder pins 4.0 mm	32 30 + 2 <sup>▲</sup>		09 27 132 7903 09 27 132 7953	09 27 132 6903 09 27 132 6953		
Male connector with wrap posts 13 mm	32 30 + 2 <sup>▲</sup>		09 27 132 7907 09 27 132 7957	09 27 132 6907 09 27 132 6957		

Male connector with press-in pins

Part Nos. and variants see chapter 04

## Dimensions

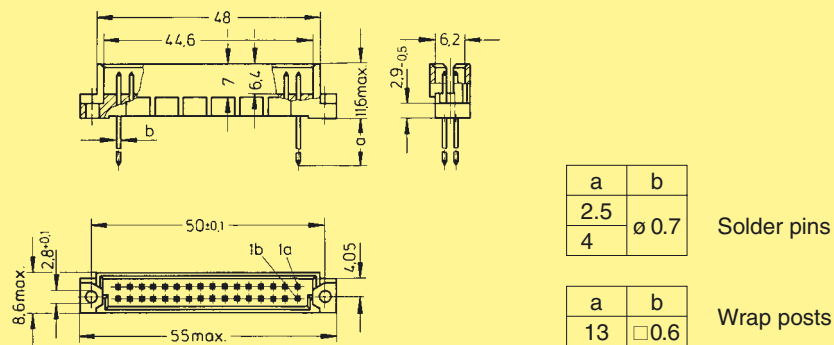

## Panel cut out

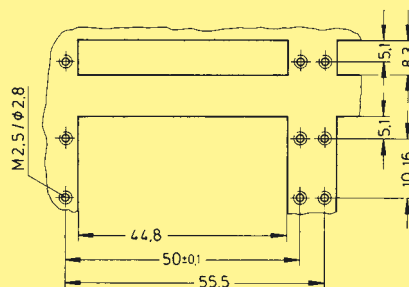

## Board drillings

Mounting side

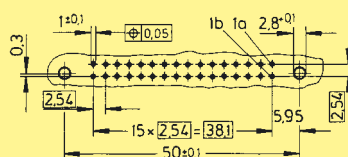

Dimensions in mm

▲ Male connectors with 2 leading contacts [(0.8 mm) pos. a1 and a16]  
Other contact arrangements as well with lagging pins on request

# DIN 41 612 · complementary type 2R



Number of contacts

# 48, 32

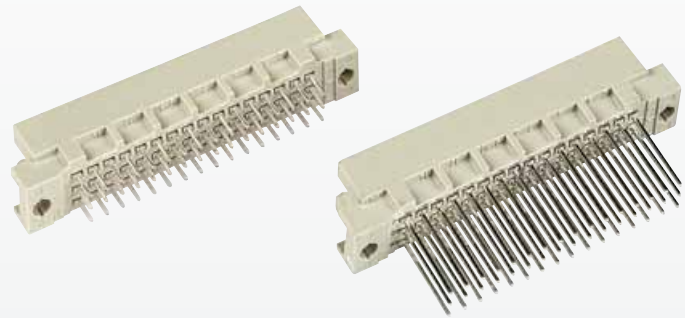

## Male connectors

Identification	Number of contacts	Contact arrangement	Part No.	Performance levels according to IEC 60 603-2. Explanation chapter 00		
				3	2	1
Male connector with solder pins 2.5 mm	48		09 28 148 7902	09 28 148 6902	09 28 148 2902	
	46 + 2 <sup>▲</sup>		09 28 148 7952	09 28 348 6902 <sup>b)</sup>	09 28 148 2952	
	32		09 28 132 7902	09 28 132 6902	09 28 132 2902	
Male connector with solder pins 4.0 mm	48		09 28 148 7903	09 28 148 6903	09 28 148 2903	
	46 + 2 <sup>▲</sup>		09 28 148 7953	09 28 348 6903 <sup>b)</sup>	09 28 148 2953	
	32		09 28 132 7903	09 28 132 6903	09 28 132 2903	
Male connector with wrap posts 13 mm	48		09 28 148 7907	09 28 148 6907	09 28 148 2907	
	46 + 2 <sup>▲</sup>		09 28 148 7957	09 28 148 6957	09 28 148 2957	
	32		09 28 132 7907	09 28 132 6907	09 28 132 2907	

Male connector with press-in pins

Part Nos. and variants see chapter 04

Dimensions

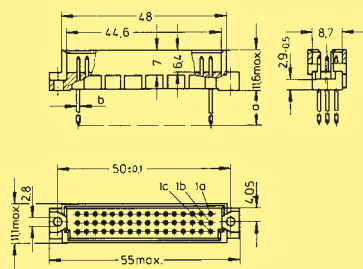

a	b
2.5	∅ 0.7
4	

Solder pins

a	b
13	□ 0.6

Wrap posts

Panel cut out

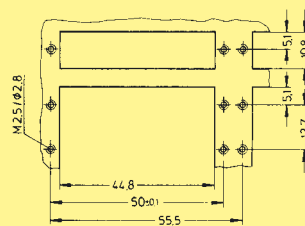

Contact arrangement  
View from termination side

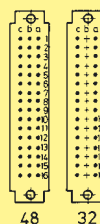

Board drillings  
Mounting side

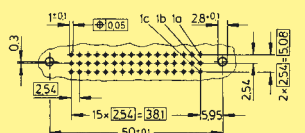

Dimensions in mm

<sup>▲</sup> Male connectors with 2 leading contacts [(0.8 mm) pos. a1 and a16]  
Other contact arrangement on request  
<sup>b)</sup> Connectors with snap-in clips see chapter 00



# DIN 41 612 · Type Q – complementary types 2Q, 2R



Number of contacts

# 64, 48, 32

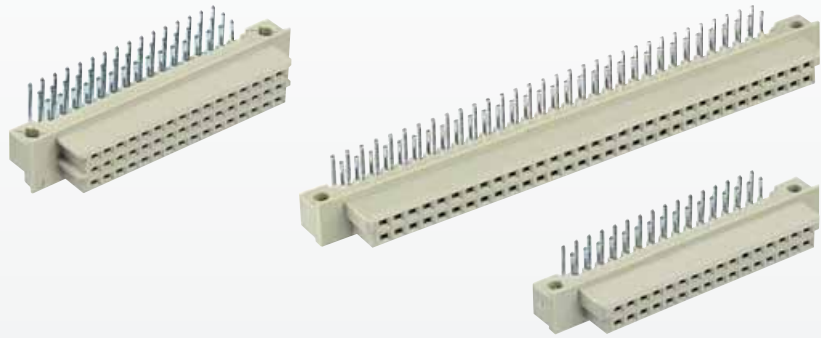

Female connectors

Identification      Number of contacts      Contact arrangement      Performance level 2 according to IEC 60 603-2. Explanation chapter 00      Part No.

Female connector with angled solder pins

Type Q

64



09 72 264 6801

Type 2Q

32



09 27 232 6801

Type 2R

48



09 28 248 6801

Dimensions

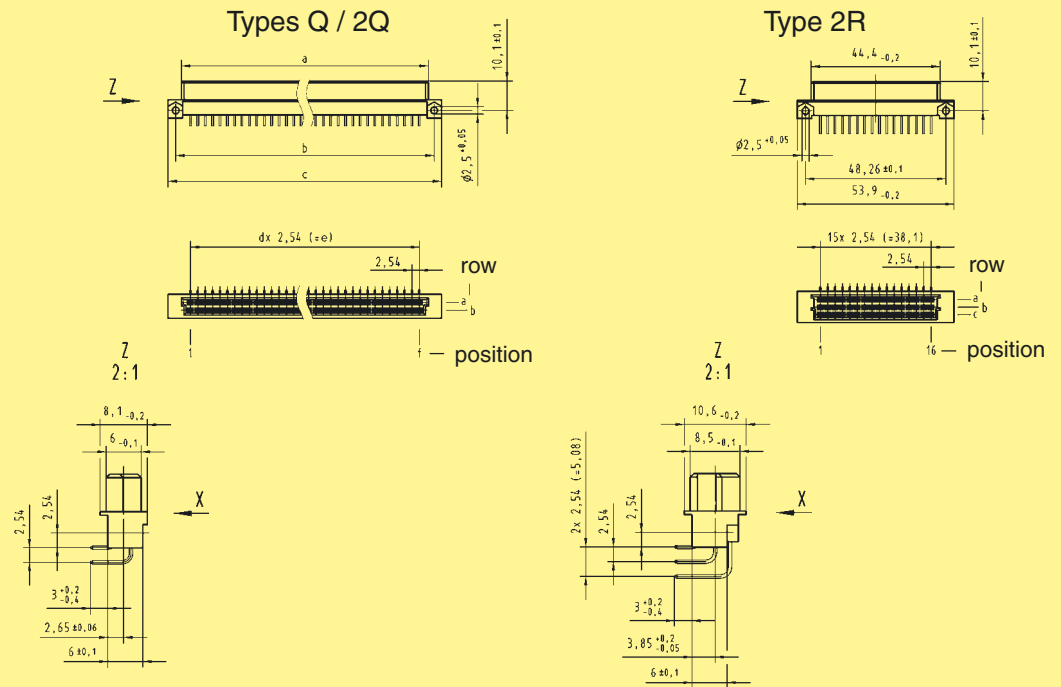

Type	a	b	c	d	e	f
Q	85.0 <sup>-0.2</sup>	88.90 <sup>±0.1</sup>	94.0 <sup>-0.2</sup>	31	78.74	32
2Q	44.4 <sup>-0.2</sup>	48.26 <sup>±0.1</sup>	53.9 <sup>-0.2</sup>	15	38.10	16

Board drillings  
Mounting side

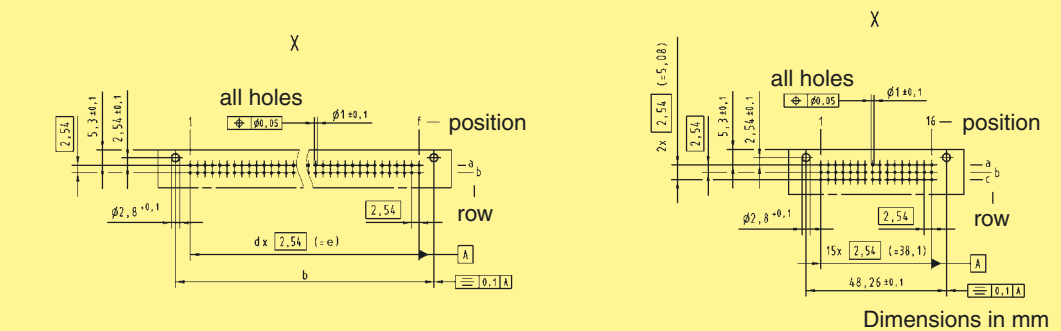



Dimensions in mm

Other contact arrangements on request

DIN Signal to 2 A

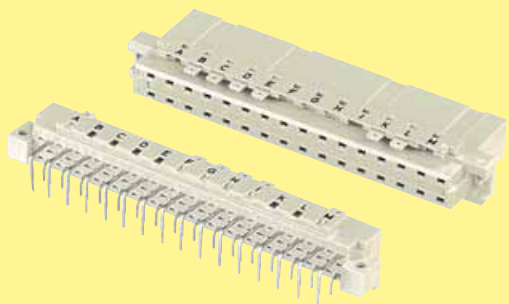
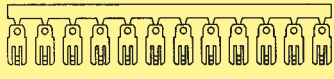
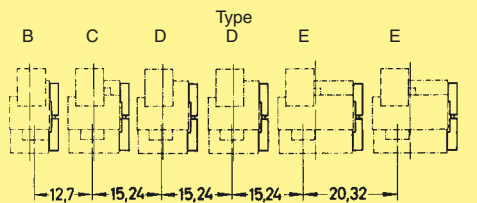
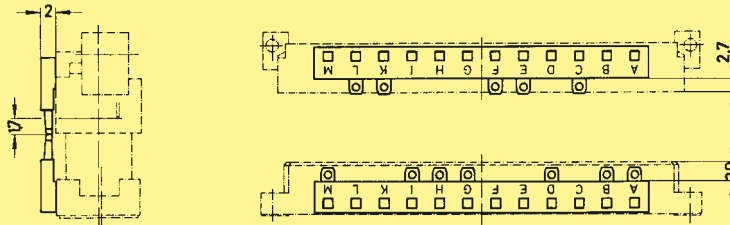
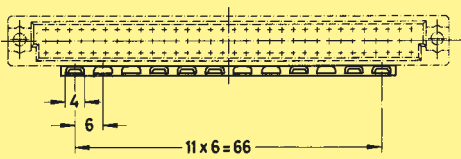
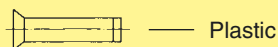
DIN Signal to 2 A

Identification	Part No.	Drawing	Dimensions in mm
<p>Coding system <u>without</u> contact loss</p>	<p>Male and female connectors</p> <p>Types B, C, D and E</p> <p>see product pages or on request</p>	<p>To avoid accidental and incorrect mating of adjacent connectors a coding system is required. This coding system is an integral part of both male and female connectors. A comb with 12 coding pins, which is supplied under a single part number, allows over 900 coding variations. The pins are to be locked into the male and female connectors.</p> <p>The connectors with the integrated coding facility are supplied for types B, C, D and E and are available for all variants.</p> <p>Please contact us.</p> 	
<p>Coding pins</p> <p>Mounting example</p>	<p>12 pins on a comb</p> <p>09 02 000 9928</p>	   	
<p>Coding system <u>with</u> contact loss</p>	<p>Code pin for types B, 2B, C, 2C, M, M-flat, Q, 2Q, R, R (HE 11), 2R, har-bus 64</p> <p>09 02 000 9901</p> <p>Removal tool for male contacts</p> <p>09 99 000 0133</p>	<p>To avoid accidental and incorrect mating of adjacent connectors a coding system is required. The coding is achieved by means of a code pin which is inserted into the selected chamber of the female connector (the contact cavity must be filled with a female contact!). The opposite male contact must be removed with the help of the specially designed tool.</p>  	

## X-ON Electronics

Largest Supplier of Electrical and Electronic Components

*Click to view similar products for [DIN 41612 Connectors](#) category:*

*Click to view products by [HARTING](#) manufacturer:*

Other Similar products are found below :

[09231126901](#) [PCN10F-24P-2.54DS\(72\)](#) [004.767](#) [02221602702](#) [024069](#) [602427301412000](#) [013275](#) [691327-1](#) [74670-0732](#) [74680-0340](#)  
[75880-0015](#) [76453-0014](#) [86093159ALF](#) [923454](#) [QLC260R](#) [120X10099X](#) [120X10019X](#) [120X10089X](#) [120X10129X](#) [121A10039X](#)  
[121A10309X](#) [122A10019X](#) [122A10029X](#) [122A10249X](#) [122A10669X](#) [122A11089X](#) [122A13089X](#) [121B10409X](#) [122A10089X](#)  
[122A10129X](#) [122A10349X](#) [122A13359X](#) [1377391-4](#) [DIN-048CPC-SR1-MH](#) [1393583-2](#) [1393726-7](#) [140X10059X](#) [140X10129X](#) [143-1913-](#)  
[000](#) [143-1908-000](#) [1484472-1](#) [173052](#) [2110070-1](#) [2110070-2](#) [CBC20T00-008FDS5-0-1-002VR](#) [983-0SE12-12P6](#) [17041102202](#) [172699-](#)  
[5036](#) [173051](#) [20](#) [8457096](#) [010](#) [025](#)